

Instruction: Pistol Grip Replacement Kit

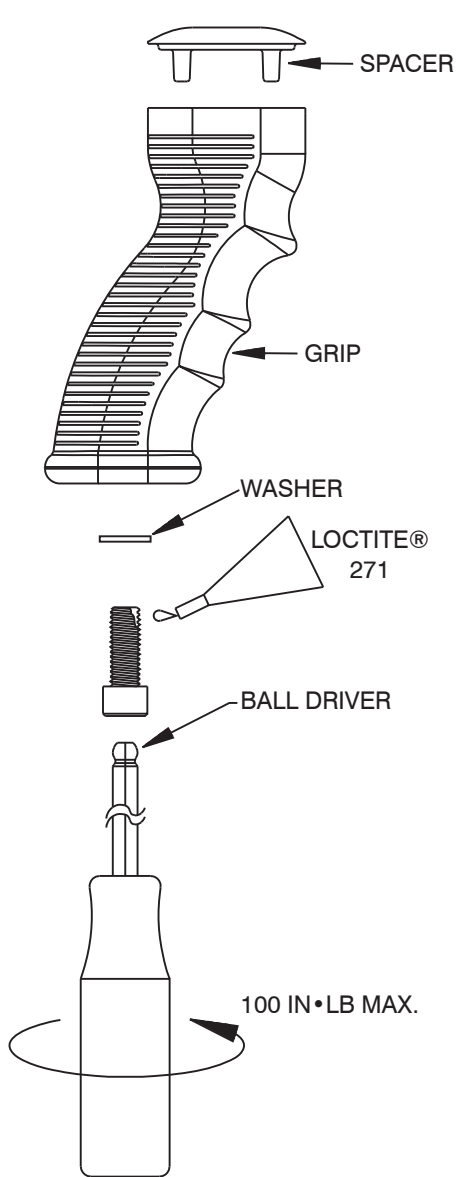

- 1) Remove old grip from valve body by inserting a 5/16" ball-point hex driver into the bottom of the grip and unscrewing the mounting screw.
- 2) Remove the mounting screw, washer, grip, and spacer.
- 3) Wipe the screw thread clean to remove any debris.
- 4) Place the washer on the clean screw and insert the screw into the bottom of the new pistol grip so that it protrudes through the hole in the middle.
- 5) Place the spacer on top of the new grip so that the screw protrudes through the hole in that as well.
- 6) Place enough adhesive on the threads of the mounting screw so that the first five threads are 'wetted' with adhesive.
- 7) Place the new grip assembly on the nozzle valve body and thread the mounting screw into the screw hole in the valve body.
- 8) Tighten the mounting screw to a maximum torque of 100 in/lbs.

HM692BLK-KIT	BLACK GRIP
HM692BLU-KIT	BLUE GRIP
HM692GRY-KIT	GRAY GRIP
HM692GRN-KIT	GREEN GRIP
HM692ORG-KIT	ORANGE GRIP
HM692PNK-KIT	PINK GRIP
HM692PPL-KIT	PURPLE GRIP
HM692RED-KIT	RED GRIP
HM692TAN-KIT	TAN GRIP
HM692WHT-KIT	WHITE GRIP
HM692YEL-KIT	YELLOW GRIP

Instruction: Pistol Grip Replacement Kit

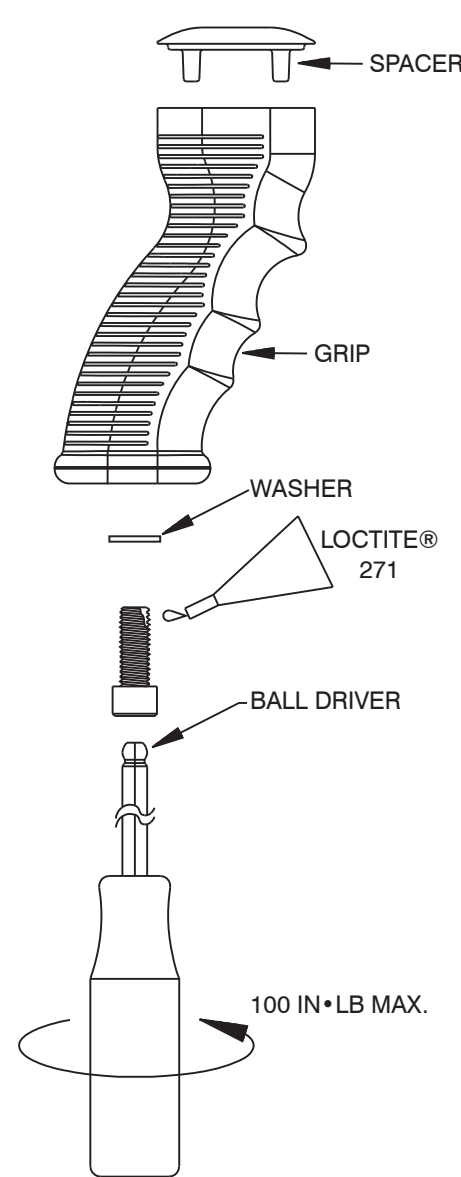

- 1) Remove old grip from valve body by inserting a 5/16" ball-point hex driver into the bottom of the grip and unscrewing the mounting screw.
- 2) Remove the mounting screw, washer, grip, and spacer.
- 3) Wipe the screw thread clean to remove any debris.
- 4) Place the washer on the clean screw and insert the screw into the bottom of the new pistol grip so that it protrudes through the hole in the middle.
- 5) Place the spacer on top of the new grip so that the screw protrudes through the hole in that as well.
- 6) Place enough adhesive on the threads of the mounting screw so that the first five threads are 'wetted' with adhesive.
- 7) Place the new grip assembly on the nozzle valve body and thread the mounting screw into the screw hole in the valve body.
- 8) Tighten the mounting screw to a maximum torque of 100 in/lbs.

HM692BLK-KIT	BLACK GRIP
HM692BLU-KIT	BLUE GRIP
HM692GRY-KIT	GRAY GRIP
HM692GRN-KIT	GREEN GRIP
HM692ORG-KIT	ORANGE GRIP
HM692PNK-KIT	PINK GRIP
HM692PPL-KIT	PURPLE GRIP
HM692RED-KIT	RED GRIP
HM692TAN-KIT	TAN GRIP
HM692WHT-KIT	WHITE GRIP
HM692YEL-KIT	YELLOW GRIP



Pistol Grip Replacement Kit Spacer Identification

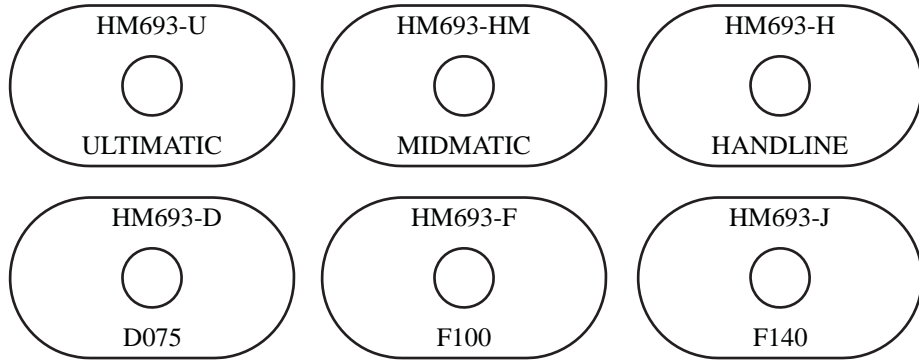

Nozzle Type	Spacer Part Number
Ultimatic	HM693-U
Mid-Matic, Mid-Force	HM693-HM
Handline, Dual-Force, VIT	HM693-H
D75 Series	HM693-D
D100 Series, F Series, G-Force	HM693-F
J Series	HM693-J

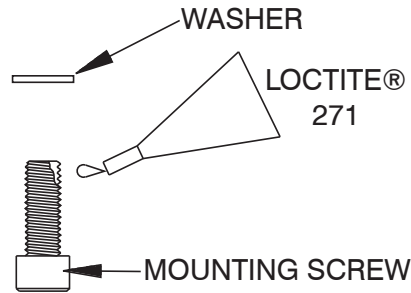

This Kit will not fit if:

Your Ultimatic, Midmatic, Mid-Force, Handline or Dual-Force nozzle has a pistol grip that looks like this

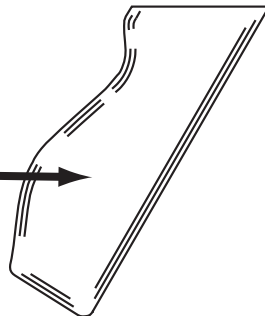

or has a serial numbers lower than TFT*-325000.



Pistol Grip Replacement Kit Spacer Identification

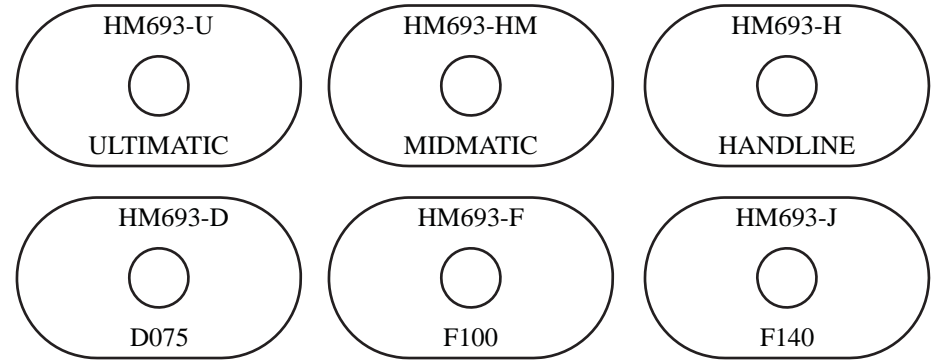

Nozzle Type	Spacer Part Number
Ultimatic	HM693-U
Mid-Matic, Mid-Force	HM693-HM
Handline, Dual-Force, VIT	HM693-H
D75 Series	HM693-D
D100 Series, F Series, G-Force	HM693-F
J Series	HM693-J

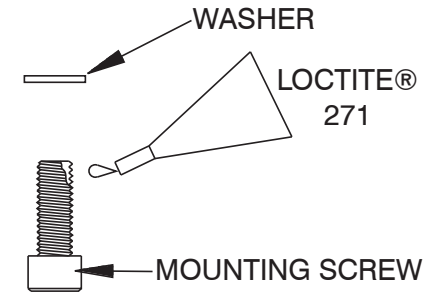

This Kit will not fit if:

Your Ultimatic, Midmatic, Mid-Force, Handline or Dual-Force nozzle has a pistol grip that looks like this

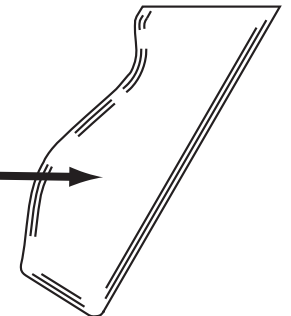

or has a serial numbers lower than TFT*-325000.