



TFT HAND HELD AUTOMATIC PRESSURE CONTROL NOZZLES

ULTIMATIC, MID-MATIC & HANDLINE

INSTRUCTIONS FOR INSTALLATION, SAFE OPERATION AND MAINTENANCE

⚠ WARNING

Read instruction manual before use. Operation of this nozzle without understanding the manual and receiving proper training can be dangerous and is a misuse of this equipment. Call 800-348-2686 with any questions.

⚠ WARNING

This instruction manual is intended to familiarize firefighters and maintenance personnel with the operation, servicing and safety procedures associated with the Ultimatic, Mid-Matic and Handline fire fighting nozzles.

⚠ WARNING

This manual should be kept available to all operating and maintenance personnel.

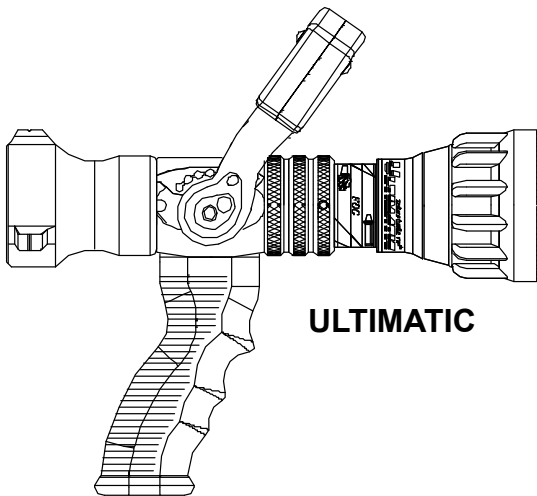

ULTIMATIC

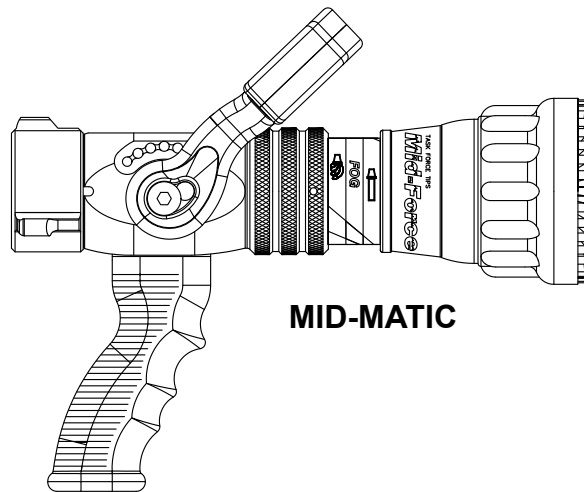

MID-MATIC

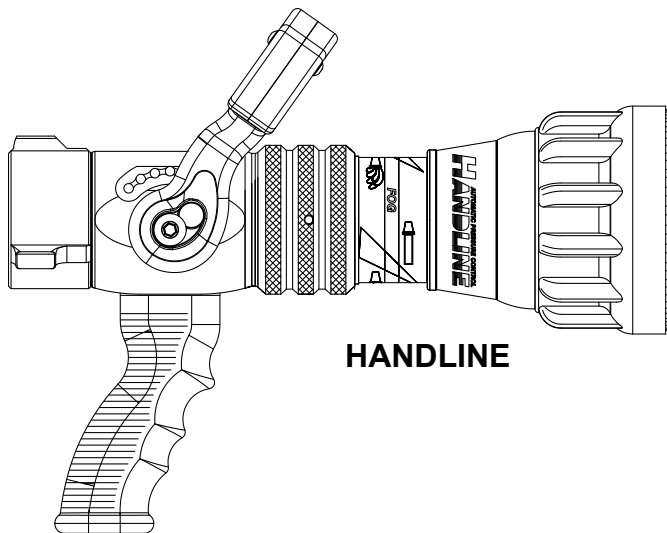

HANDLINE

TASK FORCE TIPS, INC.
MADE IN USA • www.tft.com

3701 Innovation Way, Valparaiso, IN 46383-9327 USA
800-348-2686 • 219-462-6161 • Fax 219-464-7155

Table Of Contents

- 1.0 MEANING OF SIGNAL WORDS
- 2.0 GENERAL INFORMATION
 - 2.1 VARIOUS MODELS AND TERMS
 - 2.2 COLOR CODED VALVE HANDLE COVERS - MID-MATIC & HANDLINE ONLY
- 2.3 MECHANICAL SPECIFICATIONS
- 3.0 FLOW CHARACTERISTICS
 - 3.1 REACH & TRAJECTORY
 - 3.2 USE WITH SALT WATER
- 4.0 NOZZLE CONTROLS
 - 4.1 FLOW CONTROL
 - 4.1.1 LEVER TYPE FLOW CONTROL
 - 4.1.2 TWIST SHUTOFF
 - 4.1.3 TIP ONLY NOZZLES
 - 4.2 PATTERN AND FLUSH CONTROL
 - 4.2.1 PATTERN CONTROL
 - 4.2.2 FLUSH CONTROL 5
- 5.0 USE OF ULTIMATIC, MID-MATIC & HANDLINE NOZZLES
- 6.0 FIELD INSPECTION
- 7.0 WARRANTY
- 8.0 ANSWERS TO YOUR QUESTIONS
- 9.0 NOZZLE FLOW CHARTS
- 10.0 INSPECTION CHECKLIST



PERSONAL RESPONSIBILITY CODE

The member companies of FEMSA that provide emergency response equipment and services want responders to know and understand the following:

1. Firefighting and Emergency Response are inherently dangerous activities requiring proper training in their hazards and the use of extreme caution at all times.
2. It is your responsibility to read and understand any user's instructions, including purpose and limitations, provided with any piece of equipment you may be called upon to use.
3. It is your responsibility to know that you have been properly trained in Firefighting and /or Emergency Response and in the use, precautions, and care of any equipment you may be called upon to use.
4. It is your responsibility to be in proper physical condition and to maintain the personal skill level required to operate any equipment you may be called upon to use.
5. It is your responsibility to know that your equipment is in operable condition and has been maintained in accordance with the manufacturer's instructions.
6. Failure to follow these guidelines may result in death, burns or other severe injury.



FEMSA

Fire and Emergency Manufacturers and Service Association
P.O. Box 147, Lynnfield, MA 01940 • www.FEMSA.org

1.0 MEANING OF SAFETY SIGNAL WORDS

A safety related message is identified by a safety alert symbol and a signal word to indicate the level of risk involved with a particular hazard. Per ANSI standard Z535.6-2006, the definitions of the four signal words are as follows:



DANGER indicates a hazardous situation which, if not avoided, will result in death or serious injury.



WARNING indicates a hazardous situation which, if not avoided, could result in death or serious injury.



CAUTION indicates a potentially hazardous situation which, if not avoided, may result in minor or moderate injury.



NOTICE is used to address practices not related to personal injury.

2.0 GENERAL INFORMATION

The Task Force Tips Ultimatic, MID-MATIC and Handline nozzles are designed to provide excellent performance under most fire fighting conditions. Their rugged construction is compatible with the use of fresh water (see section 5.0 for saltwater use) as well as fire fighting foam solutions. Other important operating features are:

- Slide valve with valve handle detent flow control for excellent stream quality at all valve positions
- Quick-acting pattern control from straight stream to wide fog
- "Power fog teeth" for full-fill fog
- "Gasket grabber" inlet screen to keep large debris from entering nozzle
- Easily flushable while flowing to clear trapped debris
- TFT's five-year warranty and unsurpassed customer service

2.1 VARIOUS MODELS AND TERMS

SERIES	FLOW RANGE		NOMINAL PRESSURE		STANDARD COUPLING*
	GPM	L/min	PSI	BAR	
ULTIMATIC	10-125	40-500	100	7	1, 1-1/2 NH or 1-1/4 NPSH
	10-100	40-400	75	6	1, 1-1/2 NH or 1-1/4 NPSH
MID-MATIC	70-200		100	7	1-1/2 NH
	70-200	100-600	75	6	1-1/2 NH
HANDLINE	95-300	190-1350	100	7	1-1/2 or 2-1/2 NH
	95-250	200-950	75	6	1-1/2 or 2-1/2 NH

* Other threads, coupling sizes, or connector styles can be specified at time of order.

Ultimatic, MID-MATIC and Handline nozzles are available in several models. Some common models are shown in figure 1.



Nozzle must be mated to a hose line with matched threads. Mismatched or damaged threads may cause nozzle to leak or uncouple from hose under pressure and could cause injury.

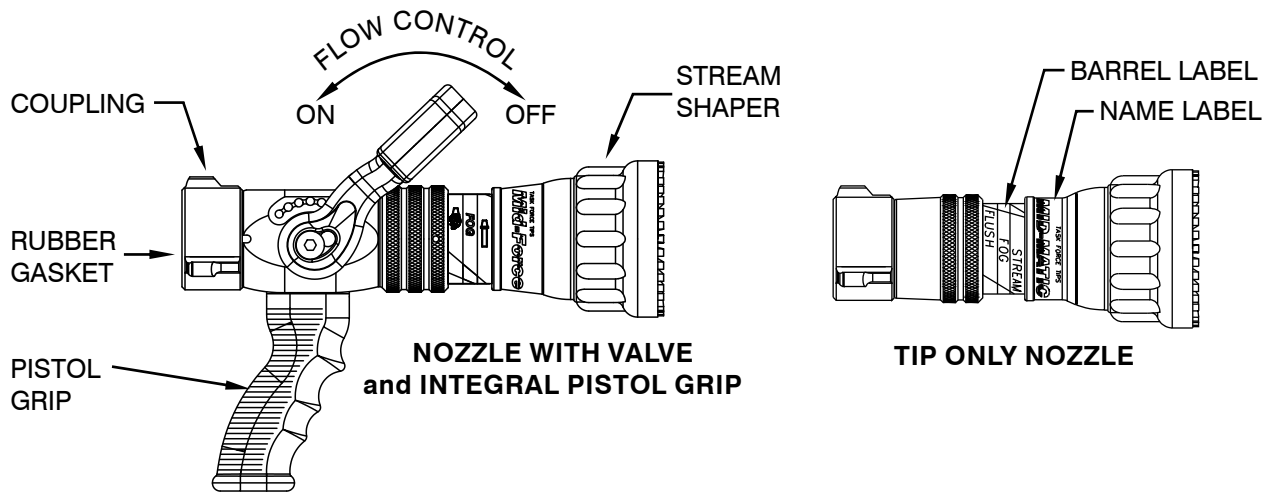

FIGURE 1 COMMON MODELS AND TERMS

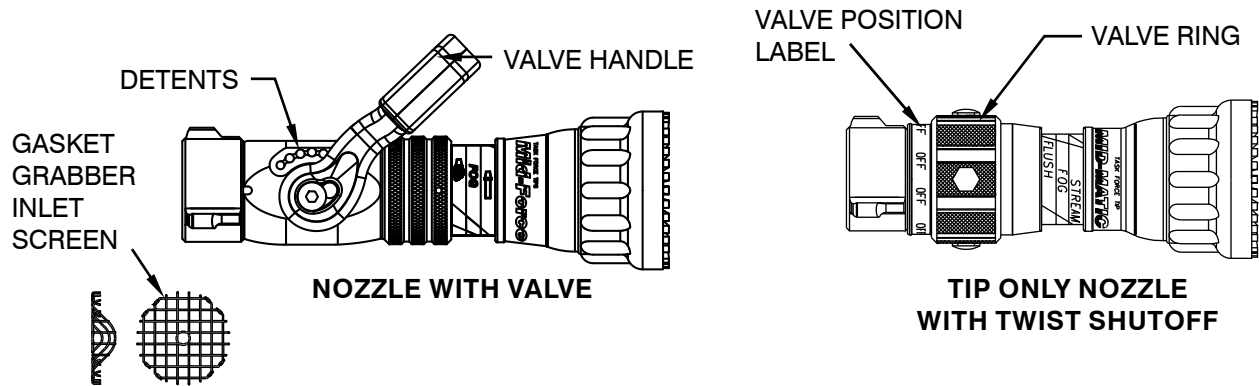

FIGURE 1 COMMON MODELS AND TERMS

2.2 COLOR CODED VALVE HANDLE AND PISTOL GRIP

The TFT ULTIMATIC, MID-MATIC & HANDLINE with lever type valve handles are supplied with black valve handle covers and pistol grips. The handle covers and pistol grips are available from TFT in various colors for those departments wishing to color code the nozzle to the discharge controls. A colored handle cover set will be sent upon receipt of the warranty card by TFT. Your department's name can also be engraved on the covers (see warranty card for more information).

Handle covers are replaceable by removing the four screws that hold the handle covers in place. Use a 3/32" allen wrench when replacing screws. Pistol grip is replaceable by following TFT instruction sheet LTT-108.

For standardization NFPA 1901 (A-4-9.3) recommends the following color code scheme:

Preconnect #1 or Bumper Jump Line	Orange	Other Colors Available:
Preconnect or discharge #2	Red	• Gray
Preconnect or discharge #3	Yellow	• Pink
Preconnect or discharge #4	White	• Purple
Preconnect or discharge #5	Blue	• Tan
Preconnect or discharge #6	Black	
Preconnect or discharge #7	Green	
Foam Lines	Red w/ White border (Red/White)	

2.3 MECHANICAL SPECIFICATIONS

Maximum nozzle inlet pressure with valve shutoff	Ultimatic 800 psi	55 bar
	Mid-Matic 300 psi	21 bar
	Handline 300 psi	21 bar
Operating temperature range of fluid	33 to 120° F	1 to 50° C
Storage temperature range	-40 to 150° F	-40 to 65° C
Materials used	Aluminum 6000 series hard anodized MIL8625 class 3 type 2, stainless steel 300 series, nylon 6-6, nitrile rubber	

3.0 FLOW CHARACTERISTICS

The graphs in figure 2 show the typical performance of ULTIMATIC, MID-MATIC and HANDLINE nozzles.

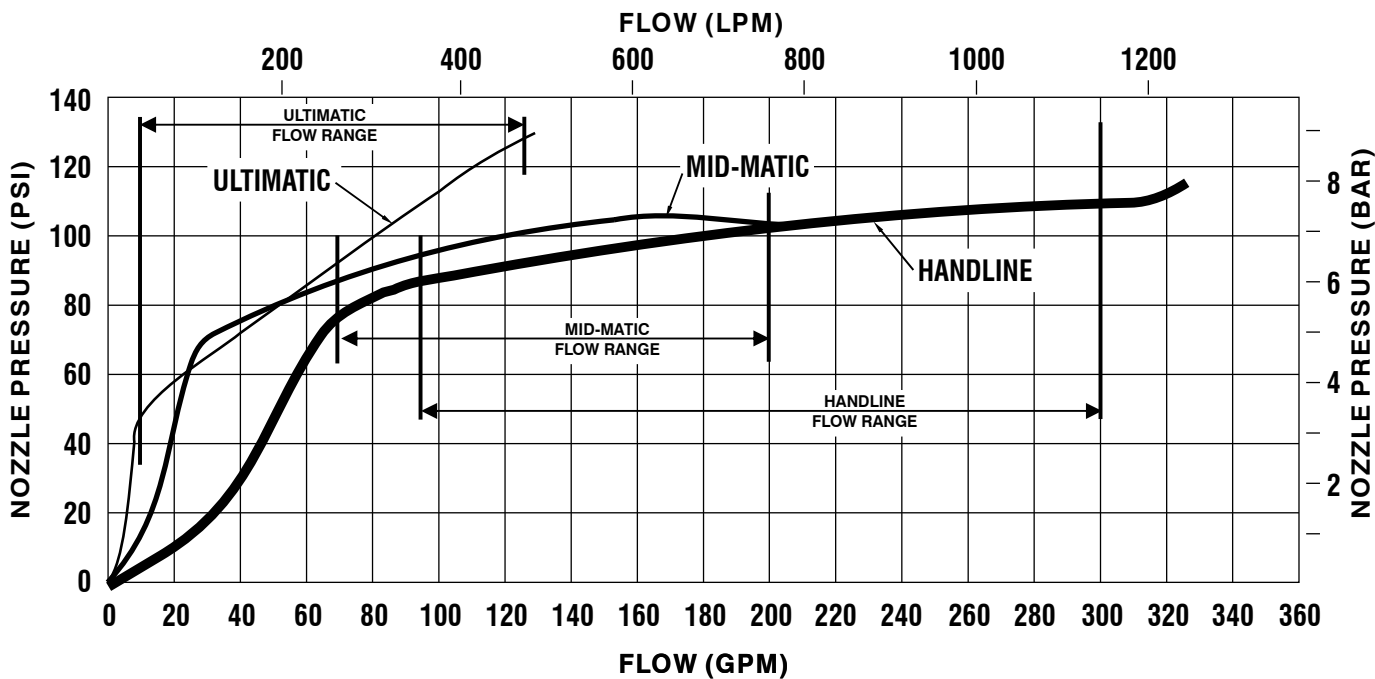

100 PSI ULTIMATIC, MID-MATIC & HANDLINE

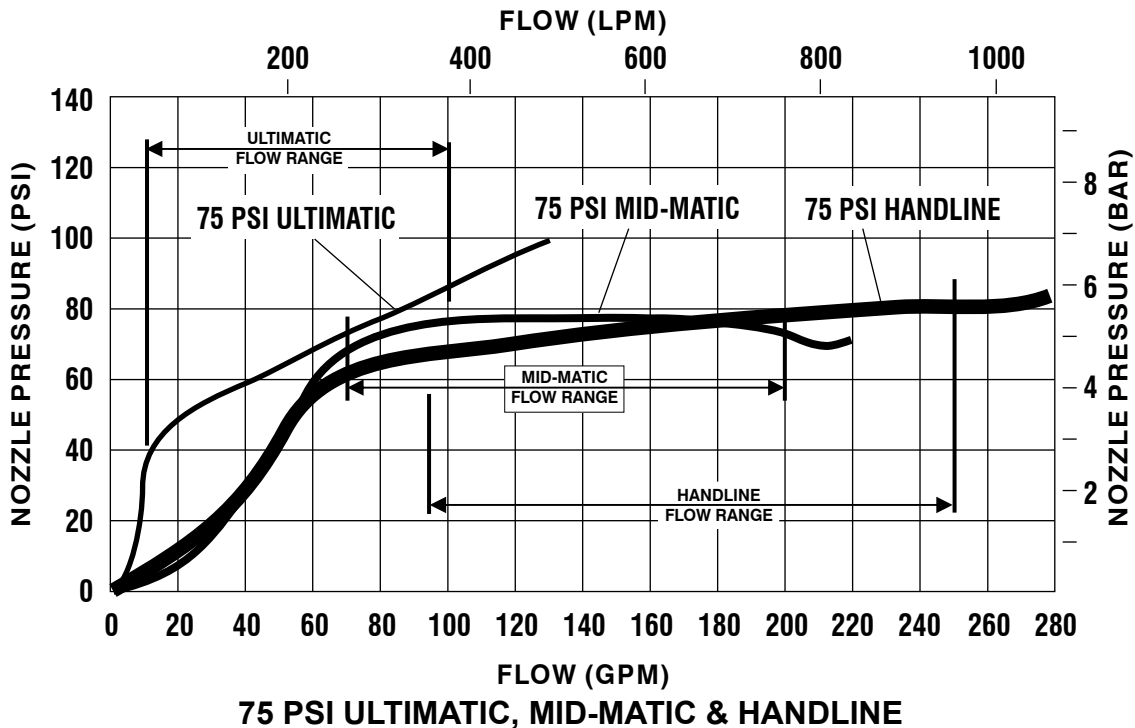

FIGURE 2

The charts in section 8.0 of this document give specific examples of maximum flow rates for particular situations. Friction losses may vary due to differences in hose construction resulting in flows different than those shown. For situations or lengths of hose not listed on the chart, approximate flows can be calculated using conventional hydraulics.

⚠ DANGER An inadequate supply of nozzle pressure and/or flow will cause an ineffective stream and can result in injury, death or loss of property. See flow chart in section 8.0 or call 800-348-2686 for assistance.

⚠ WARNING Failure to restrain nozzle reaction can cause firefighter injury from loss of footing and/or stream protection. Nozzle reaction will vary as supply conditions change: such as opening or closing other nozzles, hose line kinks, changes in pump settings, etc. Changes in spray pattern or flushing will also affect nozzle reaction. The nozzle operator must always be positioned to restrain the nozzle reaction in the event of those changes.

⚠ WARNING Injury from whipping can occur. If nozzle gets out of control or away from operator, retreat from nozzle immediately. Do not attempt to regain control of nozzle while flowing water.

⚠ CAUTION Fire streams are capable of injury and damage. Do not direct water stream to cause injury or damage to persons or property.

3.1 REACH AND TRAJECTORY

Specific data is published in technical documents LTT-140 and LTT-145 entitled Reach & Trajectory Data of Hand Held Nozzles.

3.2 USE WITH SALT WATER

Use with salt water is permissible provided nozzle is thoroughly cleaned with fresh water after each use. The service life of the nozzle may be shortened due to the effects of corrosion and is not covered under warranty.

4.0 NOZZLE CONTROLS

4.1 FLOW CONTROL

4.1.1 LEVER TYPE FLOW CONTROL

On models that use a lever type valve handle, the nozzle is shut off when the handle is fully forward. The valve handle has six detent flow positions. These detent positions allow the nozzle operator to regulate the flow of the nozzle depending on the need or what can be safely and effectively handled. TFT recommends the use of a pistol grip for easier handling. For additional stress reduction, a hose rope or strap may also be used. This permits more effective use and ease of advancement, while minimizing strain and fatigue.

4.1.2 TWIST SHUTOFF

On models that use a twist flow control. The valve is opened or closed by rotating the valve ring. Rotating the ring clockwise (as seen from the operating position behind the nozzle) closes the valve, while counterclockwise rotation opens it. Detents are provided at four intermediate positions and the position of the valve is shown by the exposed valve position label.

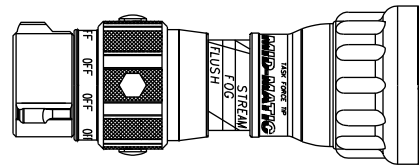

4.1.3 TIP ONLY NOZZLES

Tip only nozzles have NO shut off valve contained within the nozzle and MUST be used with a separate ball valve attached to the nozzle.

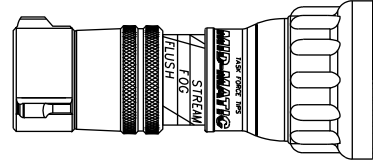

4.2 PATTERN AND FLUSH CONTROL

4.2.1 PATTERN CONTROL

TFT's ULTIMATIC, MID-MATIC and HANDLINE have full pattern control from straight stream to wide fog. Turning the STREAM SHAPER clockwise (as seen from the operating position behind the nozzle) moves the SHAPER to the straight stream position. Turning the SHAPER counterclockwise will result in an increasingly wider pattern.

Since the stream trim point varies with the flow, the stream should be "trimmed" after changing the flow to obtain the straightest and farthest reaching stream. To properly trim a stream, first open the pattern to a narrow fog. Then close the stream to parallel to give maximum reach. NOTE: Turning the shaper further forward will cause stream crossover and reduce the effective reach of the nozzle.

The nozzle reaction is greatest when the shaper is in the straight stream position. The nozzle operator must be prepared for a change in reaction as the pattern is changed.

4.2.2 FLUSH CONTROL

Small debris passes through the gasket grabber and may get caught inside the nozzle. This trapped material will cause poor stream quality, shortened reach and reduced flow. To remove this trapped debris the nozzle can be flushed as follows; while still flowing water, turn the SHAPER counterclockwise past the full fog position (increased resistance will be felt on the SHAPER as the nozzle goes into flush). This will open the nozzle allowing debris to pass through. Rotate the SHAPER clockwise and out of flush to continue normal operation. During flush the nozzle reaction will decrease as the pattern becomes wider and the pressure drops. The nozzle operator must be prepared for an increase of nozzle reaction when returning the nozzle from the flush position to retain control of the nozzle.

WARNING Large amounts of debris can reduce the flow of the nozzle resulting in an ineffective flow. In the event of a blockage it may be necessary to retreat to a safe area, uncouple nozzle and remove debris.

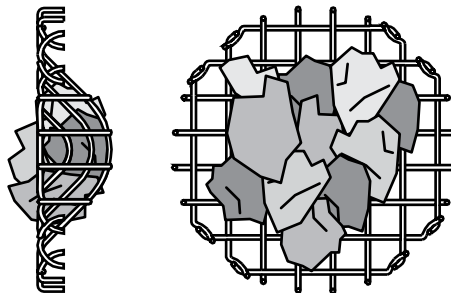

FIGURE 3 - GASKET GRABBER

5.0 USE OF ULTIMATIC, MID-MATIC and HANDLINE NOZZLES

IT IS THE RESPONSIBILITY OF THE INDIVIDUAL FIRE DEPARTMENT OR AGENCY TO DETERMINE PHYSICAL CAPABILITIES AND SUITABILITY FOR AN INDIVIDUAL'S USE OF THIS EQUIPMENT.

Many factors contribute to the extinguishment of a fire. Among the most important is delivering water at a flow rate sufficient to absorb heat faster than it is being generated. The flow rate depends largely on the pump discharge pressure and hose friction loss. The pump discharge pressure may be found by use of the chart in section 8.0. It can also be calculated using a hydraulic equation such as:



Water is a conductor of electricity. Application of water solutions on high voltage equipment can cause injury or death by electrocution. The amount of current that may be carried back to the nozzle will depend on the following factors:

Voltage of the line or equipment • Distance from the nozzle to the line or equipment
Size of the stream • Whether the stream is solid or broken • Purity of the water²



Do not couple aluminum to brass. Dissimilar metals coupled together can cause galvanic corrosion that can result in inability to unscrew threads or complete loss of thread engagement.



The nozzle may become damaged if allowed to freeze while containing water. Always drain after use to avoid damage and possible loss of use.

1 Electrostatic Hazards of Foam Blanketing Operations by Peter Howels. Industrial Fire Safety July/August 1993
2 The Fire Fighter and Electrical Equipment, The University of Michigan Extension Service, Fourth Printing 1983. Page 47.

For additional information on calculating specific hose layouts, consult an appropriate fire service training manual, A Guide to Automatic Nozzles, or call TFT's "Hydraulics Hotline" at 800-348-2686.

PDP = NP + FL + DL + EL

PDP = Pump discharge pressure in PSI
NP = Nozzle pressure in PSI
FL = Hose friction loss in PSI
DL = Device loss in PSI
EL = Elevation loss in PSI

6.0 FIELD INSPECTION

TFT's ULTIMATIC, MID-MATIC and HANDLINE are designed and manufactured to be damage resistant and require minimal maintenance. However, as the primary fire fighting tools upon which your life depends, they should be treated accordingly.

Use with saltwater is permissible provided nozzle is thoroughly cleaned with fresh water after each use. The service life of the nozzle may be shortened due to the effects of corrosion and is not covered under warranty.



Nozzle must be inspected for proper operation and function according to inspection checklist on last page before each use. Any nozzle that fails inspection is dangerous to use and must be repaired before using.

Performance tests shall be conducted on the Ultimatic, Mid-Matic and Handline nozzle after a repair, or anytime a problem is reported to verify operation in accordance with TFT test procedures. Consult factory for the procedure that corresponds to the model and serial number of the nozzle. Any equipment which fails the related test criteria should be removed from service immediately. Troubleshooting guides are available with each test procedure or equipment can be returned to the factory for service and testing.

Factory service is available with repair time seldom exceeding one day in our facility. Factory serviced nozzles are repaired by experienced technicians to original specifications, fully tested and promptly returned. Any returns should include a note as to the nature of the problem, who to reach in case of questions and if a repair estimate is required.

Repair parts and service procedures are available for those wishing to perform their own repairs. Task Force Tips assumes no liability for damage to equipment or injury to personnel that is a result of user service.

TFT Item#	Title
LIB-020	Ultimatic 125 Service Procedure
LHM-020	Mid-Matic & Mid-Force Service Procedure
LIH-020	Handline Service Procedure
LDH-020	Handline & Dual-Force Service Procedure

SPECIAL CONFIGURATIONS; If nozzles are made according to the special marking or performance requirements of the fire department then the operating characteristics may differ from the published data in this manual. Repair parts specific to each serial number may differ from those shown in the service procedure. The required parts for each serial number are available on-line by entering www.tft.123456 the with numbers corresponding to the serial number engraved on the product.

Consult TFT for laser engraved handle covers, special labeling, logos, and special laser engraving on the nozzle.



Any alterations to the nozzle and its markings could diminish safety and constitutes a misuse of this product.

All Task Force Tip nozzles are factory lubricated with high quality silicone grease. This lubricant has excellent washout resistance and long term performance. If your department has unusually hard or sandy water, the moving parts may be affected. Foam agents and water additives contain soaps and chemicals that may break down the factory lubrication.

The moving parts of the nozzle should be checked on a regular basis for smooth and free operation, and signs of damage. **IF THE NOZZLE IS OPERATING CORRECTLY, THEN NO ADDITIONAL LUBRICATION IS NEEDED.** Any nozzle that is not operating correctly should be immediately removed from service and the problem corrected.

7.0 WARRANTY

Task Force Tips, Inc., 3701 Industrial Way, Valparaiso, Indiana 46383-9327 USA (“TFT”) warrants to the original purchaser of its Ultimatic, Mid-Matic, and Handline series nozzles (“equipment”), and to anyone to whom it is transferred, that the equipment shall be free from defects in material and workmanship during the five (5) year period from the date of purchase.

TFT’s obligation under this warranty is specifically limited to replacing or repairing the equipment (or its parts) which are shown by TFT’s examination to be in a defective condition attributable to TFT. To qualify for this limited warranty, the claimant must return the equipment to TFT, at 3701 Industrial Way, Valparaiso, Indiana 46383-9327 USA, within a reasonable time after discovery of the defect. TFT will examine the equipment. If TFT determines that there is a defect attributable to it, TFT will correct the problem within a reasonable time. If the equipment is covered by this limited warranty, TFT will assume the expenses of repair.

If any defect attributable to TFT under this limited warranty cannot be reasonably cured by repair or replacement, TFT may elect to refund the purchase price of the equipment, less reasonable depreciation, in complete discharge of its obligations under this limited warranty. If TFT makes this election, claimant shall return the equipment to TFT free and clear of any liens and encumbrances.

This is a limited warranty. The original purchaser of the equipment, any person to whom it is transferred, and any person who is an intended or unintended beneficiary of the equipment, shall not be entitled to recover from TFT any consequential or incidental damages for injury to person and/or property resulting from any defective equipment manufactured or assembled by TFT. It is agreed and understood that the price stated for the equipment is in part consideration for limiting TFT’s liability. Some states do not allow the exclusion or limitation of incidental or consequential damages, so the above may not apply to you.

TFT shall have no obligation under this limited warranty if the equipment is, or has been, misused or neglected (including failure to provide reasonable maintenance) or if there have been accidents to the equipment or if it has been repaired or altered by someone else.

THIS IS A LIMITED EXPRESS WARRANTY ONLY. TFT EXPRESSLY DISCLAIMS WITH RESPECT TO THE EQUIPMENT ALL IMPLIED WARRANTIES OF MERCHANTABILITY AND ALL IMPLIED WARRANTIES OF FITNESS FOR A PARTICULAR PURPOSE. THERE IS NO WARRANTY OF ANY NATURE MADE BY TFT BEYOND THAT STATED IN THIS DOCUMENT.

This limited warranty gives you specific legal rights, and you may also have other rights which vary from state to state.

8.0 ANSWERS TO YOUR QUESTIONS

We appreciate the opportunity of serving you and making your job easier. If you have any problems or questions, our toll-free “Hydraulics Hotline”, 800-348-2686, is normally available to you 24 hours a day, 7 days a week.

9.0 NOZZLE FLOW CHARTS

100 PSI = 100 PSI ULTIMATIC

75 PSI = 75 PSI ULTIMATIC

ULTIMATIC 125 Flow Chart

FLOW (GPM)	PUMP DISCHARGE PRESSURE (PSI)	3/4" HOSE						1" HOSE						1 1/2" HOSE					
		150 ft.		200 ft.		250 ft.		150 ft.		200 ft.		250 ft.		150 ft.		200 ft.		250 ft.	
		100 PSI	75 PSI	100 PSI	75 PSI	100 PSI	75 PSI	100 PSI	75 PSI	100 PSI	75 PSI	100 PSI	75 PSI	100 PSI	75 PSI	100 PSI	75 PSI	100 PSI	75 PSI
125	10	22	—	19	—	17	23	53	20	47	18	42	70	108	60	97	50	89	
150	16	25	13	21	11	19	34	61	29	54	26	49	100	125	85	114	75	106	
175	20	27	17	24	15	21	42	68	36	60	32	55	125	—	110	—	95	118	
200	23	30	20	26	18	23	50	75	42	66	38	60	—	—	125	—	110	—	
225	26	32	22	28	20	25	56	82	48	71	42	65	—	—	—	—	125	—	
250	29	34	25	30	22	27	62	88	52	77	46	69	—	—	—	—	—	—	
300	34	38	29	33	26	30	72	99	62	86	54	78	—	—	—	—	—	—	
350	38	42	33	37	29	33	80	109	70	95	62	85	—	—	—	—	—	—	
400	42	45	36	39	32	35	90	117	78	103	68	93	—	—	—	—	—	—	
450	46	49	39	42	34	38	98	—	84	110	74	99	—	—	—	—	—	—	
500	49	52	42	45	37	40	105	—	90	117	80	106	—	—	—	—	—	—	
600	55	57	48	50	42	44	120	—	100	—	90	117	—	—	—	—	—	—	

(1) Number in each box indicates flow (GPM). (2) Flows may vary with brand or condition of hose.
 (3) Flows are approximate and do not reflect losses in preconnect piping.

7 BAR = 7 BAR ULTIMATIC

6 BAR = 6 BAR ULTIMATIC

ULTIMATIC 125 Flow Chart

FLOW (LPM)	PUMP DISCHARGE PRESSURE (BAR)	19mm HOSE						25mm HOSE						38mm HOSE					
		45M		60M		75M		45M.		60M		75M		45M		60M		75M	
		7 BAR	6 BAR	7 BAR	6 BAR	7 BAR	6 BAR	7 BAR	6 BAR	7 BAR	6 BAR	7 BAR	6 BAR	7 BAR	6 BAR	7 BAR	6 BAR	7 BAR	6 BAR
8.6	40	85	----	70	----	65	85	200	75	180	70	160	265	410	225	365	190	335	
10	60	95	50	80	40	70	130	230	110	205	100	185	380	475	320	430	285	400	
12	75	100	65	90	55	80	160	255	135	225	120	210	475	----	415	----	360	445	
14	85	115	75	100	70	85	190	285	160	250	145	225	----	----	475	----	415	----	
15.5	100	120	85	105	75	95	210	310	180	270	160	245	----	----	----	----	475	----	
17	110	130	95	115	85	100	235	335	195	290	175	260	----	----	----	----	----	----	
21	130	145	110	125	100	115	275	375	235	325	205	295	----	----	----	----	----	----	
24	145	160	125	140	110	125	305	415	265	360	235	320	----	----	----	----	----	----	
28	160	170	135	150	120	130	340	445	295	390	255	350	----	----	----	----	----	----	
31	175	185	150	160	130	145	370	----	320	415	280	375	----	----	----	----	----	----	
34	185	195	160	170	140	150	395	----	340	445	305	400	----	----	----	----	----	----	
41	210	215	180	190	160	165	455	----	380	----	340	445	----	----	----	----	----	----	

(1) Number in each box indicates flow (LPM). (2) Flows may vary with brand or condition of hose.
 (3) Flows are approximate and do not reflect losses in preconnect piping. (4) 1 BAR = 100 KPA

MID-MATIC Flow & Nozzle Reaction Chart

100 PSI = 100 PSI MID-MATIC 75 PSI = 75 PSI MID-MATIC

FLOW (GPM)
REACTION
(LBS)

PUMP DISCHARGE PRESSURE (PSI)		1 1/2" HOSE						1 3/4" HOSE						2" HOSE					
		150 ft.		200 ft.		250 ft.		150 ft.		200 ft.		250 ft.		150 ft.		200 ft.		250 ft.	
		100 PSI	75 PSI	100 PSI	75 PSI	100 PSI	75 PSI	100 PSI	75 PSI	100 PSI	75 PSI	100 PSI	75 PSI	100 PSI	75 PSI	100 PSI	75 PSI	100 PSI	75 PSI
		Flow (GPM)	Reaction (LBS)	Flow (GPM)	Reaction (LBS)	Flow (GPM)	Reaction (LBS)	Flow (GPM)	Reaction (LBS)	Flow (GPM)	Reaction (LBS)	Flow (GPM)	Reaction (LBS)	Flow (GPM)	Reaction (LBS)	Flow (GPM)	Reaction (LBS)	Flow (GPM)	Reaction (LBS)
50	21 8	49 16	21 7	48 15	21 7	46 14	21 8	51 17	21 8	50 16	21 7	49 16	22 8	52 18	22 8	52 18	22 8	51 17	
75	31 13	61 24	29 12	59 23	28 12	57 21	23 14	65 27	32 14	62 25	31 13	60 24	36 15	69 29	35 15	68 28	34 15	66 27	
100	65 30	86 37	59 27	77 33	55 25	71 30	72 34	102 45	67 32	91 40	63 29	84 36	84 41	137 61	79 38	120 35	75 36	108 48	
125	93 45	115 51	84 40	101 44	77 37	92 40	108 54	142 63	97 48	124 55	91 44	111 49	135 69	216 91	122 62	175 77	113 57	155 69	
150	117 59	141 63	105 52	123 55	96 47	110 49	141 72	178 79	125 63	153 68	114 57	137 61	196 101	---	168 87	221 95	151 78	195 85	
175	140 72	165 73	124 63	142 63	112 57	128 57	174 90	214 90	151 78	179 79	136 70	159 70	---	---	212 109	---	187 97	224 98	
200	162 84	187 81	141 73	160 71	128 65	143 64	204 105	---	175 91	204 87	157 81	179 79	---	---	---	---	222 113	---	
225	183 94	208 88	158 82	176 78	142 73	157 70	---	---	198 102	222 95	176 91	198 86	---	---	---	---	---	---	
250	202 104	221 96	174 90	198 79	155 80	179 69	---	---	218 112	---	194 100	215 91	---	---	---	---	---	---	

(1) Number on top in each box indicates flow (GPM), and number on bottom indicates nozzle reaction (LBS).
 (2) Flows may vary with brand or condition of hose. (3) Flows are approximate and do not reflect losses in preconnect piping.

MID-MATIC Flow & Nozzle Reaction Chart

7 BAR = 7 BAR MID-MATIC 6 BAR = 6 BAR MID-MATIC

FLOW (LPM)
REACTION
(KG)

PUMP DISCHARGE PRESSURE (BAR)		38mm HOSE						45mm HOSE						50mm HOSE					
		45M		60M		75M		45M		60M		75M		45M		60M		75M	
		7 BAR	6 BAR	7 BAR	6 BAR	7 BAR	6 BAR	7 BAR	6 BAR	7 BAR	6 BAR	7 BAR	6 BAR	7 BAR	6 BAR	7 BAR	6 BAR	7 BAR	6 BAR
		Flow (LPM)	Reaction (KG)	Flow (LPM)	Reaction (KG)	Flow (LPM)	Reaction (KG)	Flow (LPM)	Reaction (KG)	Flow (LPM)	Reaction (KG)	Flow (LPM)	Reaction (KG)	Flow (LPM)	Reaction (KG)	Flow (LPM)	Reaction (KG)	Flow (LPM)	Reaction (KG)
3.5	80 4	210 8	80 3	190 7	80 3	175 6	80 4	245 10	80 4	225 9	80 3	205 8	85 4	310 12	85 4	285 11	85 4	255 10	
5.2	115 6	350 14	110 5	315 12	105 5	285 11	85 6	420 17	120 6	380 15	115 6	345 14	135 7	535 23	130 7	485 20	130 7	450 19	
7	245 14	460 19	225 12	405 16	210 11	365 15	275 15	540 24	255 15	490 20	240 13	445 18	320 19	695 33	300 17	630 29	285 16	580 25	
8.6	350 20	540 24	320 18	475 20	290 17	430 18	410 25	650 30	365 22	575 25	345 20	520 23	510 31	805 41	460 28	750 36	430 26	690 32	
10	445 27	615 28	395 24	540 24	365 21	490 21	535 33	740 35	475 29	660 30	430 26	600 26	740 46	---	635 40	---	570 35	775 38	
12	530 33	680 31	470 29	600 27	425 26	540 24	660 41	805 41	570 35	725 35	515 32	660 30	---	---	800 50	---	710 44	845 45	
14	615 38	740 35	535 33	655 30	485 30	590 26	770 48	---	660 41	785 39	595 37	715 34	---	---	---	---	840 51	---	
15.5	695 43	790 40	600 37	705 33	535 33	635 29	---	---	750 46	835 44	665 41	770 38	---	---	---	---	---	---	
17	765 47	835 44	660 41	750 36	585 36	680 31	---	---	825 51	---	735 45	815 41	---	---	---	---	---	---	

(1) Number on top in each box indicates flow (LPM), and number on bottom indicates nozzle reaction (KG).
 (2) Flows may vary with brand or condition of hose. (3) Flows are approximate and do not reflect losses in preconnect piping.

HANDLINE Flow & Nozzle Reaction Chart

Note: For Nozzles with Serial # TFT-H465101 and/or Manufactured after 12/01/2003

100 PSI = 100 PSI HANDLINE 75 PSI = 75 PSI HANDLINE

PUMP DISCHARGE PRESSURE (PSI)	1 1/2" HOSE						1 3/4" HOSE						2" HOSE						2-1/2" HOSE					
	150 ft.		200 ft.		250 ft.		150 ft.		200 ft.		250 ft.		150 ft.		200 ft.		250 ft.		150 ft.		200 ft.		250 ft.	
	100 PSI	75 PSI	100 PSI	75 PSI	100 PSI	75 PSI	100 PSI	75 PSI	100 PSI	75 PSI	100 PSI	75 PSI	100 PSI	75 PSI	100 PSI	75 PSI	100 PSI	75 PSI	100 PSI	75 PSI	100 PSI	75 PSI	100 PSI	75 PSI
50	48 16	71 20	47 15	65 18	45 14	60 16	50 17	84 25	49 16	75 22	48 15	70 20	51 18	107 33	51 17	96 29	50 17	88 26	53 19	157 52	53 19	148 48	53 18	140 45
75	64 25	104 31	60 23	91 27	58 22	82 24	73 29	126 39	67 26	112 34	63 25	101 30	88 36	162 47	81 33	145 43	76 31	133 42	123 52	230 89	116 49	221 83	111 46	212 77
100	96 39	130 41	85 34	114 35	77 31	103 31	115 48	157 52	103 42	136 44	93 38	126 39	148 64	203 72	132 57	182 63	121 51	166 56	252 114	269 120	224 101	260 112	206 92	251 105
125	122 52	151 49	108 45	133 42	98 40	120 37	149 64	183 63	131 56	162 54	119 50	147 48	197 88	232 90	173 76	212 77	158 69	194 68	300 150	300 150	290 140	290 140	282 131	281 131
150	145 63	170 57	127 54	149 48	115 48	135 43	177 78	206 74	156 68	182 63	141 61	165 55	239 108	256 108	210 94	234 92	189 84	218 81	343 185	341 185	317 167	335 173	307 157	307 157
175	165 72	187 65	144 62	168 55	130 56	148 48	203 91	225 86	178 79	201 71	160 70	182 63	276 127	276 127	242 109	255 108	217 98	236 94	356 210	355 209	349 199	348 197	343 186	342 186
200	183 81	202 72	160 70	178 61	144 62	160 53	227 102	241 98	198 88	217 80	178 79	197 70	295 145	295 145	270 123	272 123	243 110	254 107	369 235	368 234	362 222	361 221	356 210	354 209
225	200 89	216 80	174 77	190 66	157 68	172 58	249 113	257 109	216 97	231 90	195 87	211 77	312 163	313 163	289 138	288 138	266 121	269 120	---	---	375 245	373 245	368 232	367 232
250	216 97	229 88	188 83	202 72	169 74	182 63	269 123	271 122	234 106	244 99	210 94	223 85	329 181	336 180	304 154	304 133	284 134	284 134	---	---	---	---	380 255	378 255

- (1) Number on top in each box indicates flow (GPM), and number on bottom indicates nozzle reaction (LBS).
 (2) Flows may vary with brand or condition of hose. (3) Flows are approximate and do not reflect losses in preconnect piping.

HANDLINE Flow & Nozzle Reaction Chart

Note: For Nozzles with Serial # TFT-H465101 and/or Manufactured after 12/01/2003

7 BAR = 7 BAR HANDLINE 6 BAR = 6 BAR HANDLINE

PUMP DISCHARGE PRESSURE (BAR)	38mm HOSE						45mm HOSE						50mm HOSE						65mm HOSE					
	45M		60M		75M		45M		60M		75M		45M		60M		75M		45M		60M		75M	
	7 BAR	6 BAR	7 BAR	6 BAR	7 BAR	6 BAR	7 BAR	6 BAR	7 BAR	6 BAR	7 BAR	6 BAR	7 BAR	6 BAR	7 BAR	6 BAR	7 BAR	6 BAR	7 BAR	6 BAR	7 BAR	6 BAR	7 BAR	6 BAR
3.5	182 7	269 9	178 7	246 8	170 6	227 7	189 8	318 11	185 7	284 10	182 7	265 9	193 8	405 15	193 8	363 13	189 8	333 12	201 9	594 24	201 9	560 22	201 8	530 20
5.2	242 11	394 14	227 10	344 12	220 10	310 11	276 13	477 18	254 12	424 15	238 11	382 14	333 16	613 24	307 15	549 21	588 14	503 19	466 24	871 40	439 22	836 38	420 21	802 35
7	363 18	492 19	322 15	431 16	291 14	390 14	435 22	594 24	390 19	526 20	352 17	477 18	560 29	768 33	500 26	689 29	458 23	628 25	954 52	1018 54	848 46	984 51	780 42	950 48
8.6	462 24	572 22	409 20	503 19	371 18	454 17	564 29	693 29	496 25	613 24	450 23	556 22	746 40	878 41	655 34	802 35	598 31	734 31	1136 68	1136 68	1098 64	1098 64	1067 59	1064 59
10	549 29	643 26	481 24	564 22	435 22	511 20	670 35	780 34	590 31	689 29	534 28	625 25	905 49	969 49	795 43	866 42	715 38	825 37	1298 84	1291 84	1200 76	1268 78	1162 71	1162 71
12	625 33	708 29	545 28	621 25	492 25	560 22	768 41	852 39	674 36	761 32	606 32	689 29	1045 58	1045 58	916 49	965 49	821 44	893 43	1347 95	1344 95	1321 90	1317 89	1298 84	1294 84
14	693 37	765 33	606 32	674 28	545 28	606 24	859 46	912 44	749 40	821 36	674 36	746 32	1117 66	1117 66	1022 56	1030 56	920 50	961 49	1397 107	1393 106	1370 101	1366 100	1347 95	1340 95
15.5	757 40	818 36	659 35	719 30	594 31	651 26	942 51	973 49	818 44	874 41	738 39	799 35	1181 74	1185 74	1094 63	1090 63	1007 55	1018 54	---	---	1419 111	1412 111	1393 105	1389 105
17	818 44	867 40	712 38	765 33	640 34	689 29	1018 56	1026 55	866 48	924 45	795 43	844 39	1245 82	1272 82	1151 70	1151 70	1075 60	1075 61	---	---	---	---	1438 116	1431 116

- (1) Number on top in each box indicates flow (LPM), and number on bottom indicates nozzle reaction (KG).
 (2) Flows may vary with brand or condition of hose. (3) Flows are approximate and do not reflect losses in preconnect piping.

10.0 INSPECTION CHECKLIST

Nozzle must be inspected for proper operation and function according to this checklist before each use.

Check that:

- 1) There is no obvious damage such as missing, broken or loose parts, damaged labels etc.
- 2) Gasket grabber is free of debris.
- 3) Coupling is tight and leak free.
- 4) Valve operates freely through full range and regulates flow.
- 5) "OFF" position does fully shut off and flow is stopped.
- 6) Nozzle flow is adequate as indicated by pump pressure and nozzle reaction.
- 7) Shaper turns freely and adjusts pattern through full range.
- 8) Shaper turns into full flush and out of flush with normal flow and pressure restored.



Any Ultimatic, Mid-Matic or Handline nozzle failing any part of the inspection checklist is unsafe and must have the problem corrected before use. Operating a nozzle that fails any of the above inspections is a misuse of this equipment.