



**TASK FORCE TIPS**  
FIRE FIGHTING EQUIPMENT

# MANUAL: ThunderFog & QuadraFog Instruction Manual

## INSTRUCTIONS FOR SAFE OPERATION AND MAINTENANCE

### **⚠ WARNING**

Read instruction manual before use. Operation of this device without understanding the manual and receiving proper training is a misuse of this equipment. A person who has not read and understood all operating and safety instructions is not qualified to operate the Thunderfog or Quadrafog nozzle.

This instruction manual is intended to familiarize firefighters and maintenance personnel with the operation, servicing and safety procedures associated with the Thunderfog and Quadrafog nozzles.

This manual should be kept available to all operating and maintenance personnel.

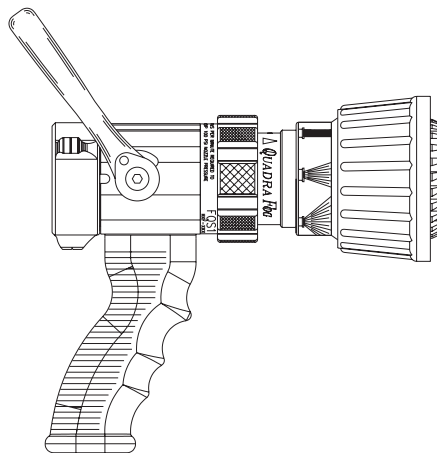
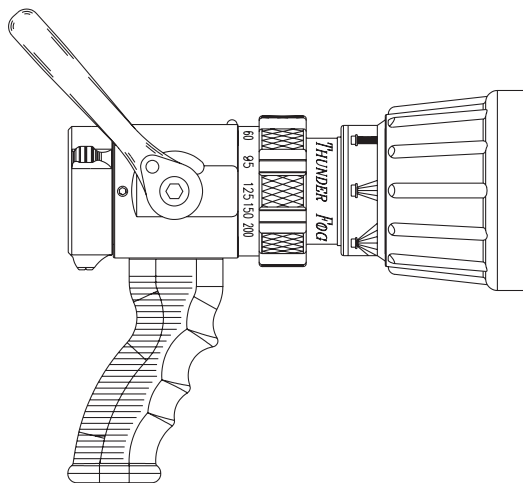
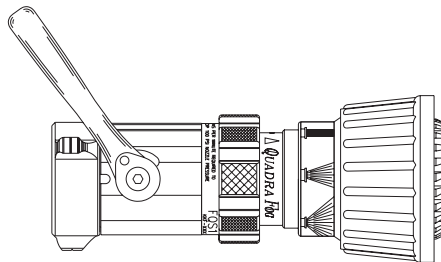
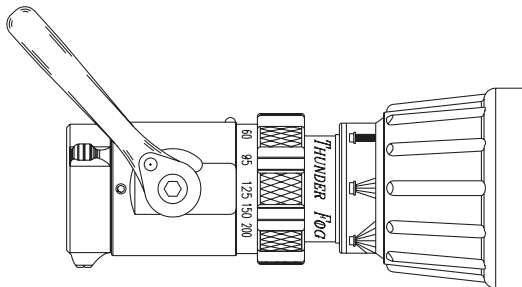
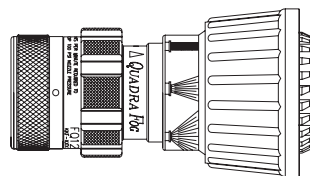
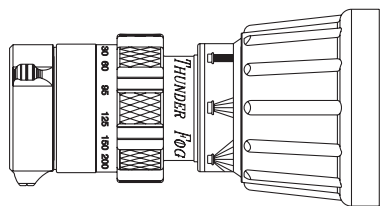

**TASK FORCE TIPS, Inc.**  
MADE IN USA • [www.tft.com](http://www.tft.com)

2800 E. Evans Ave, Valparaiso, IN 46383-6940 USA  
800-348-2686 • 219-462-6161 • Fax 219-464-7155

## TABLE OF CONTENTS

1.0	MEANING OF SAFETY SIGNAL WORDS
2.0	GENERAL INFORMATION
2.1	VARIOUS MODELS AND TERMS
2.2	NOZZLE COUPLINGS
3.0	FLOW CHARACTERISTICS
4.0	NOZZLE CONTROLS
4.1	BALL VALVE SHUTOFF
4.2	SELECTOR RING
4.2.1	FLOW SETTING
4.2.1	FLUSH SETTING
4.3	PATTERN CONTROL
5	FIREGROUND USE
6.0	FIELD INSPECTION
7.0	REPAIR
8.0	WARRANTY
9.0	ANSWERS TO YOUR QUESTIONS
10.0	INSPECTION CHECKLIST

**! DANGER**

### PERSONAL RESPONSIBILITY CODE

The member companies of FEMSA that provide emergency response equipment and services want responders to know and understand the following:

1. Firefighting and Emergency Response are inherently dangerous activities requiring proper training in their hazards and the use of extreme caution at all times.
2. It is your responsibility to read and understand any user's instructions provided with any piece of equipment you may be called upon to use.
3. It is your responsibility to know that you have been properly trained in Firefighting and /or Emergency Response and in the use, precautions, and care of any equipment you may be called upon to use.
4. It is your responsibility to be in proper physical condition and to maintain the personal skill level required to operate any equipment you may be called upon to use.
5. It is your responsibility to know that your equipment is in operable condition and has been maintained in accordance with the manufacturer's instructions.
6. Failure to follow these guidelines may result in death, burns or other severe injury.



Fire and Emergency Manufacturers and Services Association, Inc.  
P.O. Box 147, Lynnfield, MA 01940 • www.FEMSA.org

## 1.0 MEANING OF SAFETY SIGNAL WORDS

A safety related message is identified by a safety alert symbol and a signal word to indicate the level of risk involved with a particular hazard. Per ANSI standard Z535.4-1998 the definitions of the three signal words are as follows:

**! DANGER**

**DANGER indicates an imminently hazardous situation which, if not avoided, will result in death or serious injury.**

**! WARNING**

**WARNING indicates a potentially hazardous situation which, if not avoided, could result in death or serious injury.**

**! CAUTION**

**CAUTION indicates a potentially hazardous situation which, if not avoided, may result in minor or moderate injury.**

## 2.0 GENERAL INFORMATION

This manual describes nozzles calibrated at 100 psi (7 bar) and 75 psi (5 bar). Contact factory for data specific to models that operate with metric flow calibrations.

Quadrafog and Thunderfog are economical, lightweight, and dependable nozzles. Their rugged construction is compatible with the use of fresh water (see section 5.0 for saltwater use) as well as firefighting foam solutions. Other important operating features are:

- Quick-acting pattern control from straight stream to wide fog
- Fixed fog teeth
- Stainless steel spinning fog teeth available on some models
- Stainless steel shutoff ball
- Easily flushable while flowing to clear trapped debris
- Quick-change rear valve seat
- Task Force Tips five-year warranty and unsurpassed customer service

**⚠ DANGER**

An inadequate supply of nozzle pressure and/or flow will cause an ineffective stream and can result in injury, death or loss of property. See flow chart on pages 8 - 11 or call 800-348-2686 for assistance.

**⚠ WARNING**

This equipment is intended for use by trained personnel for firefighting. Their use for other purposes may involve hazards not addressed by this manual. Seek appropriate guidance and training to reduce risk of injury.

**⚠ WARNING**

Nozzle reaction will vary as supply conditions change: such as opening or closing other nozzles, hose line kinks, changes in pump settings, etc. Changes in spray pattern or flushing will also affect nozzle reaction. The nozzle operator must always be prepared in the event of those changes. Failure to restrain nozzle reaction can cause firefighter injury from loss of footing and/or stream protection.

**⚠ WARNING**

If nozzle gets out of control or away from operator, retreat from nozzle immediately. Do not attempt to regain control of nozzle while flowing water. Injury from whipping can occur.

**⚠ WARNING**

Water is a conductor of electricity. Application of water solutions on high voltage equipment can cause injury or death by electrocution. The amount of current that may be carried back to the nozzle will depend on the following factors:

- Voltage of the line or equipment
- Distance from the nozzle to the line or equipment
- Size of the stream
- Whether the stream is solid or broken
- Purity of the water<sup>1</sup>

<sup>1</sup> The Fire Fighter and Electrical Equipment, The University of Michigan Extension Service, Fourth Printing 1983. Page 47.

**⚠ CAUTION**

Fire streams are capable of injury and damage. Do not direct water stream to cause injury or damage to persons or property.

**2.1 VARIOUS MODELS AND TERMS**

**Selectable Flow:** A nozzle with a discharge orifice that can be set to a user selected position. In each position the nozzle acts as a fixed orifice nozzle.

**Fixed Flow:** A nozzle with a discharge orifice that is a fixed opening size. The user can set the opening to flush positions, or on tip only models to the OFF position.

**Tip Only:** a nozzle without an integral ball shutoff valve.

Quadrafog and Thunderfog nozzles are available in a variety of flow ranges and configurations. All models deliver the selected flow when the rated pressure is supplied to the nozzle. Flow settings and recommended hose sizes are:

SERIES	RECOMMENDED HOSE SIZE (INCHES)	FLOW SETTINGS (GPM AT 100 PSI)	NOZZLE TYPE
1" Quadrafog	3/4, 1	5, 10, 24, 40	Selectable Flow
1-1/2" Quadrafog	1-1/2	30, 60, 95, 125	Selectable Flow
200 Thunderfog	1-1/2 to 1-3/4	30, 60, 95, 125, 150, 200	Selectable Flow
250 Thunderfog	1-1/2 to 2-1/2	95, 125, 150, 200, 250	Selectable Flow

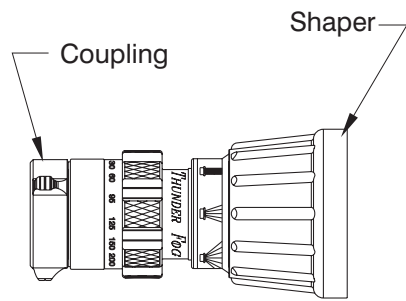

**TIP ONLY**  
(not available with 2-1/2" coupling)

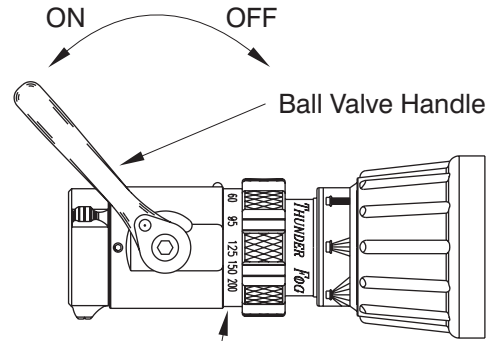

Model Number  
Serial Number  
Pressure Calibration  
**BALL VALVE**

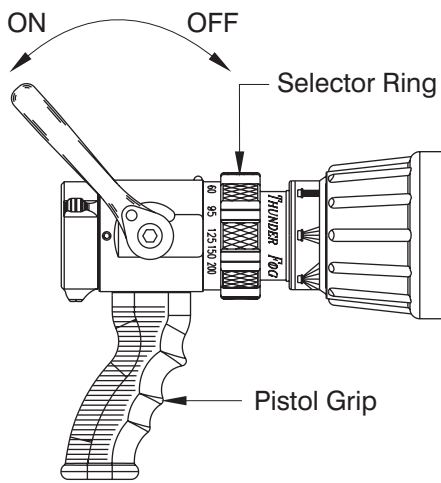

**BALL VALVE WITH PISTOL GRIP**

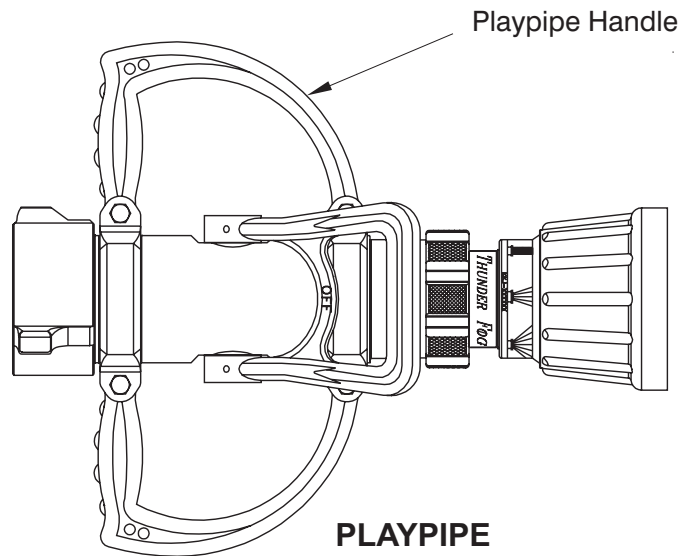

**PLAYPIPE**

**FIGURE 1 BASIC NOZZLE CONFIGURATIONS AND TERMS**

## 2.2 NOZZLE COUPLING

NH (National Hose Threads per NFPA #1963) threads are standard on all nozzles. Other threads such as NPSH (National Pipe Straight Hose threads per ANSI/ASME #B1.20.7) can be specified at time of order.

### **CAUTION**

Nozzle must be properly connected. Mismatched or damaged threads may cause nozzle to leak or uncouple under pressure and could cause injury.

### **CAUTION**

Do not couple aluminum to brass. Dissimilar metals coupled together can cause galvanic corrosion that can result in inability to unscrew threads or complete loss of thread engagement.

### 3.0 FLOW CHARACTERISTICS

At each flow setting the nozzle is set to a predetermined fixed orifice. Relationship of flow and nozzle pressure at each setting is shown in figure 2. Contact the factory or visit the website ([www.tft.com](http://www.tft.com)) for range and trajectory data.

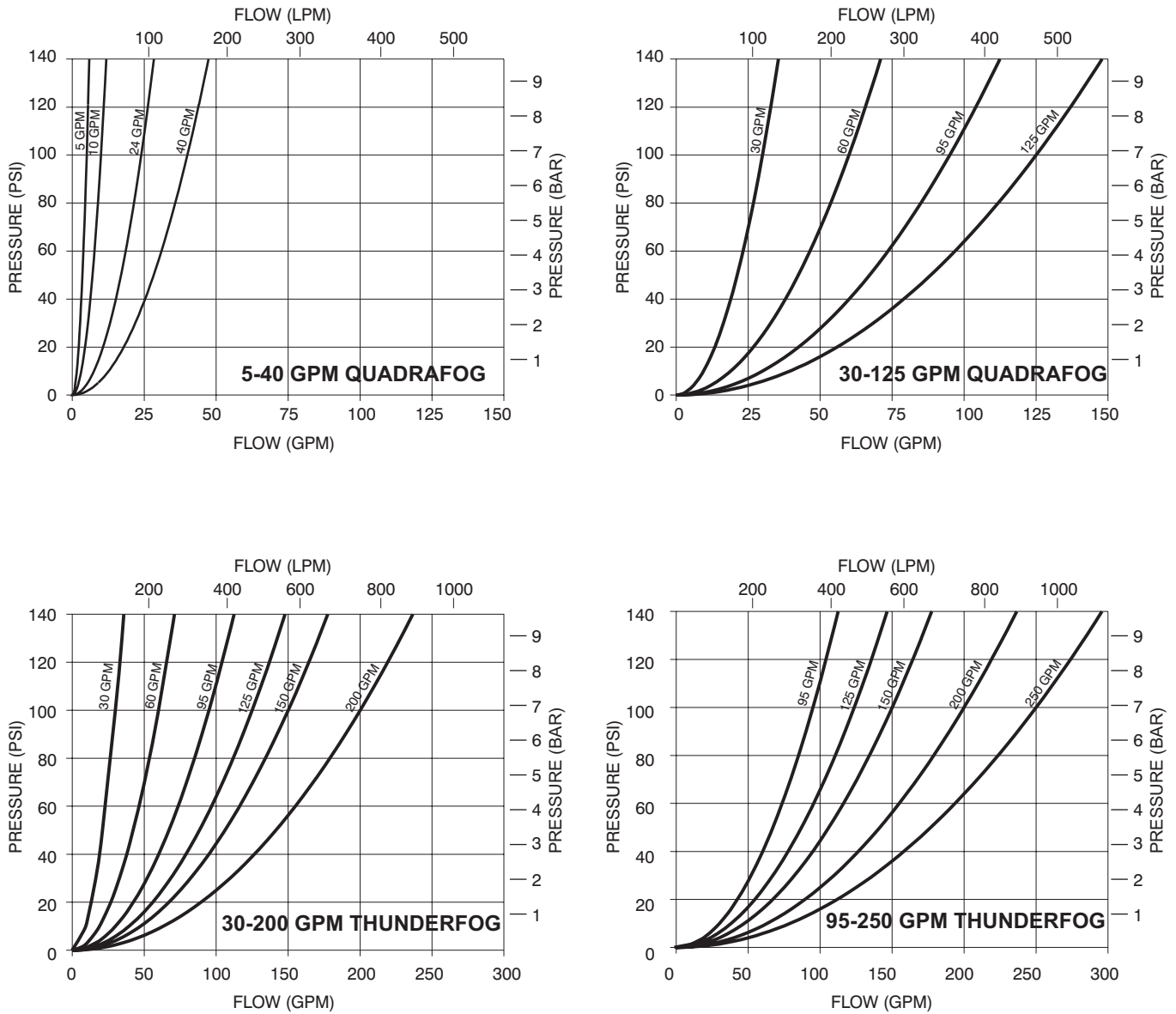

**FIGURE 2 NOZZLE FLOW CHARACTERISTICS**

The charts on pages 8-11 of this document give specific examples of pump pressure and flow for various hoses and lengths. Losses may vary due to differences in hose construction resulting in flows different than shown. For situations or lengths of hose not listed on the chart, approximate flows can be calculated using conventional hydraulics.

## 4.0 NOZZLE CONTROLS

### 4.1 BALL VALVE SHUTOFF

Models with a ball valve are shut off when the valve handle is fully forward. Pulling back on the handle opens the valve. Open valve slowly to avoid sudden changes in nozzle reaction. Close valve slowly to prevent water hammer. Note: In partially open positions a ball valve will cause turbulence and adversely affect stream quality.

### 4.2 SELECTOR RING

#### 4.2.1 FLOW SETTING

The selector ring is marked with various flow settings. Turn the selector ring so the desired setting lines up with the silver indicator pin. A spring-loaded detent is provided at each flow setting. **The nozzle will flow the indicated amount when the pressure at the nozzle is 100 PSI (7 bar) or 75 PSI (5 bar) on low pressure versions.**

#### 4.2.2 FLUSH SETTING

Debris may become trapped in the nozzle causing poor stream quality, shortened reach and reduced flow. To remove trapped debris, the nozzle can be flushed as follows: While still flowing water, rotate the selector ring into the flush position. This will open up the nozzle, allowing debris to pass through. Rotate the selector ring out of flush to continue normal operations. The nozzle operator must be prepared for a change in nozzle reaction when returning the nozzle from the flush position to retain control of the nozzle.



**Large amounts or pieces of debris may be unflushable and can reduce the flow of the nozzle resulting in an ineffective flow. In the event of a blockage, it may be necessary to retreat to a safe area, uncouple nozzle and remove debris.**

#### 4.2.3 SHUTOFF SETTING (TIP-ONLY MODELS)

On tip-only models the selector ring has a shutoff setting to stop the nozzle flow. To shut off the nozzle, rotate the selector ring clockwise (as seen from the operating position behind the nozzle) into the "OFF" position. Rotate counterclockwise into a flow setting to open nozzle.

### 4.3 PATTERN CONTROL

The Quadrafog and Thunderfog nozzles have full pattern control from straight stream to wide fog. Turning the SHAPER clockwise (as seen from the operating position behind the nozzle) moves the SHAPER to the straight stream position. Turning the SHAPER counterclockwise will result in an increasingly wider pattern. Since the stream trim point varies with the flow, the stream should be 'trimmed' after changing the flow to obtain the straightest and furthest reaching stream. The nozzle reaction is greatest when the shaper is in the straight-stream position. The nozzle operator must be prepared for a change in reaction as the pattern is changed.

## 5.0 FIREGROUND USE

***IT IS THE RESPONSIBILITY OF THE INDIVIDUAL FIRE DEPARTMENT OR AGENCY TO DETERMINE PHYSICAL CAPABILITIES AND SUITABILITY FOR AN INDIVIDUAL'S USE OF THIS EQUIPMENT.***

Many factors contribute to the extinguishment of a fire. Among the most important is delivering water at a flow rate sufficient to absorb heat faster than is being generated. The flow rate depends largely on the pump discharge pressure and hose friction loss. The pump discharge pressure may be found by use of the chart on the last page. It can also be calculated using a hydraulic equation such as:

$$PDP = NP + FL + DL + EL$$

**PDP** = Pump discharge pressure in PSI

**NP** = Nozzle pressure in PSI

**FL** = Hose friction loss in PSI

**DL** = Device loss in PSI

**EL** = Elevation loss in PSI

For additional information on calculating specific hose layouts, consult an appropriate fire-service training manual, such as *A Firefighters Guide To Nozzles* published by Task force Tips, or call TFT's "Hydraulics Hotline" at 800-348-2686.

## 6.0 FIELD INSPECTION

Quadrafog and Thunderfog nozzles are designed and manufactured to be damage resistant and require minimal maintenance. However, as the primary firefighting tool upon which your life depends, it should be treated accordingly.

Use with saltwater is permissible provided nozzle is thoroughly cleaned with fresh water after each use. The service life of the nozzle may be shortened due to the effects of corrosion and is not covered under warranty.

**⚠ WARNING** Nozzle must be inspected before each use for proper operation and function according to inspection checklist on last page of this document. Any nozzle that fails inspection is dangerous to use and must be repaired before using.

Performance tests shall be conducted on the nozzle after a repair, or anytime a problem is reported to verify operation in accordance with Task Force Tips test procedures. Consult factory for the test procedure that corresponds to the model and serial number of the nozzle. Any equipment which fails the related test criteria should be removed from service immediately. Troubleshooting guides are available with each test procedure or equipment can be returned to the factory for service and testing.

**⚠ CAUTION** Any alteration to the nozzle and its markings constitutes a misuse of this product and could diminish safety.

All nozzles are factory lubricated with high-quality silicone grease. This lubricant has excellent washout resistance and long-term performance. If your department has unusually hard or sandy water, the moving parts may be affected. Foam agents and water additives contain soaps and chemicals that may break down the factory lubrication.

The moving parts of the nozzle should be checked on a regular basis for smooth and free operation and signs of damage. **IF THE NOZZLE IS OPERATING CORRECTLY, THEN NO ADDITIONAL LUBRICATION IS NEEDED.** Any nozzle that is not operating correctly should be immediately removed from service and the problem corrected.

## 7.0 REPAIR

Factory service is available with repair time seldom exceeding one day in our facility. Factory-serviced nozzles are repaired by experienced technicians to original specifications, fully wet tested, and promptly returned. Repair charges for non-warranty items are minimal. Any returns should include a note as to the nature of the problem and whom to reach in case of questions.

Task Force Tips assumes no liability for damage to equipment or injury to personnel that is a result of user service.

Repair kits and repair parts are stocked for immediate shipment. Contact the factory or visit the website at [www.tft.com](http://www.tft.com) for parts lists, exploded views, test procedures and trouble shooting guides.

## 8.0 WARRANTY

Task Force Tips, Inc., 2800 East Evans Avenue, Valparaiso, Indiana 46383-6940 ("TFT") warrants to the original purchaser of its Quadrafog and Thunderfog nozzles and other equipment ("equipment"), and to anyone to whom it is transferred, that the equipment shall be free from defects in material and workmanship during the five (5) year period from the date of purchase.

TFT's obligation under this warranty is specifically limited to replacing or repairing the equipment (or its parts) which are shown by TFT's examination to be in a defective condition attributable to TFT. To qualify for this limited warranty, the claimant must return the equipment to TFT, at 2800 East Evans Avenue, Valparaiso, Indiana 46383-6940, within a reasonable time after discovery of the defect. TFT will examine the equipment. If TFT determines that there is a defect attributable to it, it will correct the problem within a reasonable time. If the equipment is covered by this limited warranty, TFT will assume the expenses of repair.

If any defect attributable to TFT under this limited warranty cannot be reasonably cured by repair or replacement, TFT may elect to refund the purchase price of the equipment, less reasonable depreciation, in complete discharge of its obligations under this limited warranty. If TFT makes this election, claimant shall return the equipment to TFT free and clear of any liens and encumbrances.

This is a limited warranty. The original purchaser of the equipment, any person to whom it is transferred, and any person who is an intended or unintended beneficiary of the equipment, shall not be entitled to recover from TFT any consequential or incidental damages for injury to person and/or property resulting from any defective equipment manufactured or assembled by TFT. It is agreed and understood that the price stated for the equipment is in part consideration for limiting TFT's liability. Some states do not allow the exclusion or limitation of incidental or consequential damages, so the above may not apply to you.

TFT shall have no obligation under this limited warranty if the equipment is, or has been, misused or neglected (including failure to provide reasonable maintenance) or if there have been accidents to the equipment or if it has been repaired or altered by someone else.

THIS IS A LIMITED EXPRESS WARRANTY ONLY. TFT EXPRESSLY DISCLAIMS WITH RESPECT TO THE EQUIPMENT ALL IMPLIED WARRANTIES OF MERCHANT ABILITY AND ALL IMPLIED WARRANTIES OF FITNESS FOR A PARTICULAR PURPOSE. THERE IS NO WARRANTY OF ANY NATURE MADE BY TFT BEYOND THAT STATED IN THE DOCUMENT.

This limited warranty gives you specific legal rights, and you may also have other rights which vary from state to state.

## 9.0 ANSWERS TO YOUR QUESTIONS

We appreciate the opportunity of serving you and making your difficult job easier. If you have any problems or questions, our toll-free "Hydraulics Hotline" is normally available to you 24 hours a day, 7 days a week at 800-348-2686.

## 10.0 INSPECTION CHECKLIST

Nozzle must be inspected before each use for proper operation and function according to this checklist. Check that:

- 1) There is no obvious damage such as missing, broken or loose parts, damaged labels, etc.
- 2) Coupling is tight and leak free
- 3) Valve handle moves freely through full range and shuts off flow
- 4) Nozzle flow is adequate as indicated by pump pressure and nozzle reaction
- 5) Selector ring turns into all positions including flush
- 6) Shaper turns freely and adjusts pattern through full range



**Any nozzle failing any part of the inspection checklist is unsafe and must have the problem corrected before use. Operating a nozzle that fails any of the above inspections is a misuse of this equipment.**

**TASK FORCE TIPS, Inc.**  
MADE IN USA • [www.tft.com](http://www.tft.com)

2800 E. Evans Ave, Valparaiso, IN 46383-6940 USA  
800-348-2686 • 219-462-6161 • Fax 219-464-7155