



# MANUAL: IVUM and IVUM RC 4" INDUSTRIAL VALVE UNDER MONITOR

## INSTRUCTIONS FOR INSTALLATION, SAFE OPERATION AND MAINTENANCE

### **⚠ WARNING**

Understand manual before use. Operation of this device without understanding the manual and receiving proper training is a misuse of this equipment. Obtain safety information at [www.tft.com/serial-number](http://www.tft.com/serial-number)

### HYDROSTATIC PROOF TEST:

1220 psi (84 bar)

### SAFE OPERATING RANGE:

Up to 2500 gpm below 130 psi\* (9500 l/min @ 9 bar)

Up to 2000 gpm below 200 psi\* (8000 l/min @ 14 bar)

Up to 1600 gpm @ 300 psi maximum\* (6000 l/min @ 21 bar)

\*these maximum flow rates and nozzle inlet pressures are valid for monitor outlets up to 18.6" (472mm) tall from the IVUM outlet. Read section 4.2 for details.

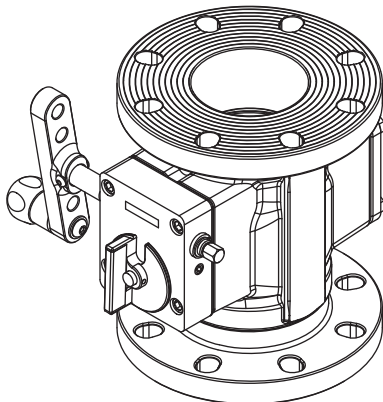

model ZAAZ3 or ZASZ3  
with 4" ANSI 150 outlet  
(shown from gearbox side)

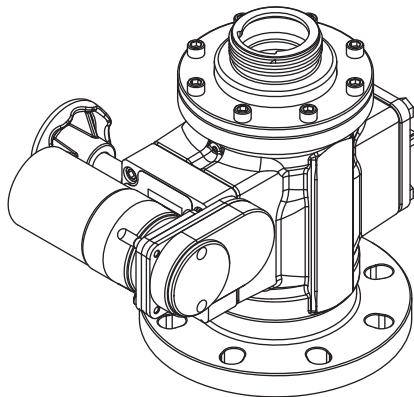

model ZAAZT-RC or ZASZT-RC  
with 2.5" NH quick connect for Tornado  
monitor (shown from gearbox side)

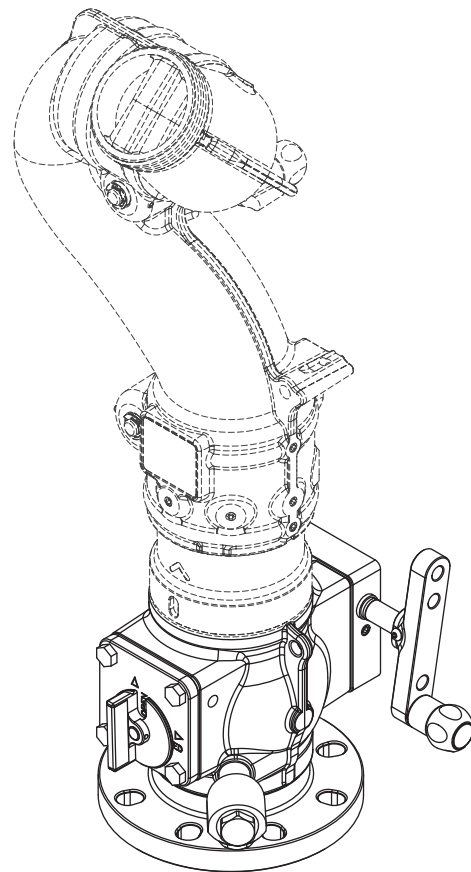

model ZAAZX or ZASZX  
for integrated TFT monitor  
(shown from secondary position indicator side with Y5-D21A-Z)

**TASK FORCE TIPS, INC.**  
MADE IN USA • [www.tft.com](http://www.tft.com)

3701 Innovation Way, Valparaiso, IN 46383-9327 USA  
800-348-2686 • 219-462-6161 • Fax 219-464-7155

## Table Of Contents

- 1.0 MEANING OF SAFETY SIGNAL WORDS
- 2.0 SAFETY
- 3.0 GENERAL INFORMATION
  - 3.1 SPECIFICATIONS
    - 3.1.1 MECHANICAL SPECIFICATIONS
    - 3.1.2 ELECTRICAL SPECIFICATIONS
  - 3.2 CORROSION
  - 3.3 USE WITH SALT WATER
  - 3.4 PARTS IDENTIFICATION AND INTENDED ORIENTATION
  - 3.5 OVERALL DIMENSIONS AND WEIGHTS
  - 3.6 SIDE 'B' MONITOR OUTLET OPTIONS
- 4.0 INSTALLATION
  - 4.1 STRUCTURAL REQUIREMENTS FOR PIPE FLANGE MOUNTED MONITORS
  - 4.2 MONITOR INSTALLATION
    - 4.2.1 SIDE 'B' OPTIONS 3,4, V – FLANGED MONITORS
    - 4.2.2 SIDE 'B' OPTIONS X – INTEGRATED MONITORS
    - 4.2.3 SIDE 'B' OPTIONS Q and T – QUICK CONNECT MONITORS AND ELBOWS
    - 4.2.4 SIDE 'B' OPTIONS 1 and 2 – CODE-RPM DIRECT CONNECTION
  - 4.3 ELECTRIC INSTALLATION AND WIRING
    - 4.3.1 INTERFACE ENCLOSURE MOUNTING
  - 4.4 ELECTRICAL TESTING
  - 4.5 INPUTS SIGNAL CONFIGURATION
  - 4.6 VALVE POSITION FEEDBACK RELAYS
  - 4.7 AUX BUTTON OPERATION
- 5.0 USE
  - 5.1 OPERATION AND VALVE POSITION INDICATORS
  - 5.2 ELECTRIC REMOTE CONTROL – MANUAL OVERRIDE
  - 5.3 ELECTRIC REMOTE CONTROL OPERATION
  - 5.4 LOCKOUT/TAGOUT
  - 5.5 DRAINING RESIDUAL WATER
- 6.0 VALVE FRICTION LOSS
- 7.0 EXPLODED VIEWS AND PARTS LISTS
  - 7.1 MAIN VALVE ASSEMBLY EXPLODED VIEW
  - 7.2 HALF BALL [A] EXPLODED VIEWS
  - 7.3 SECONDARY POSITION INDICATOR [B] EXPLODED VIEW
  - 7.4 WORM GEARBOX [C] EXPLODED VIEW
  - 7.5 RC MOTOR ASSEMBLY [D] EXPLODED VIEW
- 8.0 TEMPLATES
- 9.0 WARRANTY
- 10.0 MAINTENANCE
  - 10.1 TROUBLE SHOOTING
  - 10.2 REPAIRS
  - 10.3 CRANKSHAFT OVERRIDE AND REPLACEMENT
  - 10.4 VALVE SEAT REPLACEMENT
- 11.0 ANSWERS TO YOUR QUESTIONS
- 12.0 INSPECTION CHECKLIST

**▲ DANGER**

### PERSONAL RESPONSIBILITY CODE

The member companies of FEMSA that provide emergency response equipment and services want responders to know and understand the following:





1. Firefighting and Emergency Response are inherently dangerous activities requiring proper training in their hazards and the use of extreme caution at all times.
2. It is your responsibility to read and understand any user's instructions, including purpose and limitations, provided with any piece of equipment you may be called upon to use.
3. It is your responsibility to know that you have been properly trained in Firefighting and /or Emergency Response and in the use, precautions, and care of any equipment you may be called upon to use.
4. It is your responsibility to be in proper physical condition and to maintain the personal skill level required to operate any equipment you may be called upon to use.
5. It is your responsibility to know that your equipment is in operable condition and has been maintained in accordance with the manufacturer's instructions.
6. Failure to follow these guidelines may result in death, burns or other severe injury.









Fire and Emergency Manufacturers and Service Association  
P.O. Box 147, Lynnfield, MA 01940 • www.FEMSA.org

## 1.0 MEANING OF SAFETY WORDS

A safety related message is identified by a safety alert symbol and a signal word to indicate the level of risk involved with a particular hazard. Per ANSI standard Z535.6-2011, the definitions of the four signal words are as follows:

-  **DANGER** indicates a hazardous situation which, if not avoided, will result in death or serious injury.
-  **WARNING** indicates a hazardous situation which, if not avoided, could result in death or serious injury.
-  **CAUTION** indicates a potentially hazardous situation which, if not avoided, could result in minor or moderate injury.
-  **NOTICE** is used to address practices not related to physical injury.

## 2.0 SAFETY

-  **WARNING** Quick changes in valve position can cause high pressure spikes due to water hammer and may result in damaged equipment which could lead to injury or death. Open and close the valve slowly to avoid water hammer.
-  **WARNING** Injury or death may occur by attempting to use a damaged valve. Before using the valve inspect it for damage resulting from:
- Failure to drain monitor followed by exposure to freezing conditions.  
See section DRAINING RESIDUAL WATER for instructions.
  - Exposure of monitor to temperatures in excess of 160 degrees F
  - Missing parts, physical abuse, exposure to severe chemicals
  - Deformed or cracked flanges damaged as a result of improper installation
    - o Excessive bolt torque
    - o Wrong tightening sequence
-  **WARNING** Injury can result from an inadequately supported monitor and valve. The monitor/valve mount must be capable of supporting 1500 lbs (680 kg) of nozzle reaction force.
-  **WARNING** This equipment is intended for use by trained personnel for firefighting. Their use for other purposes may involve hazards not addressed by this manual. Seek appropriate guidance and training to reduce risk of injury.
-  **CAUTION** Maximum operating pressure 300 psi (21 bar). Do not exceed 300 psi (21 bar) on either side of the valve.
-  **CAUTION** Valve must be properly connected. Mismatched or damaged threads may cause nozzle to leak or uncouple under pressure and could cause injury.
-  **NOTICE** To prevent mechanical damage, do not drop or throw equipment.

### 3.0 GENERAL INFORMATION

The 4" Industrial Valve Under Monitor (IVUM) is a robust, low friction loss valve intended for installation directly beneath monitors on standpipes with 4" ANSI 150 or DN 100 PN16 flange connections. Dual reflective valve position indicators allow 360 degree visual confirmation from a distance in all light conditions. The inlet flange, half ball and valve seat retainer are available in either hard anodized 6061-T6 aluminum or 316 stainless steel. Several options are available for monitor connection, as described in section 3.6. When paired with a TFT monitor, the monitor flange is omitted to reduce weight, up-front cost and future maintenance expenses.

### 3.1 SPECIFICATIONS

#### 3.1.1 MECHANICAL SPECIFICATIONS

MODELS	4" IVUM and IVUM RC
Valve Seat Diameter	3.65" (93mm)
Maximum Pressure	300 psi (21 bar)
Maximum Flow at Specified Nozzle Inlet Pressure	2500 gpm @ 130 psi (9500 l/min @ 9 bar)
	2000 gpm @ 200 psi (8000 l/min @ 14 bar)
	1600 gpm @ 300 psi (6000 l/min @ 21 bar)
Hydrostatic Proof	1220 psi (84 bar)
Temperature Rating*	-25° to 135°F (-32° to 57°C)
Worm Drive Gearbox Reduction	7.5 turns open to closed (30:1)
* For temperatures below 32°F (0°C), standpipe must be drained after use to avoid damage. See section 5.5 DRAINING RESIDUAL WATER for instructions.	

#### 3.1.2 ELECTRICAL SPECIFICATIONS

MODELS	IVUM RC only			
Opening/Closing Speed	6 seconds			
Voltage-Auto Sense	12 or 24 Volt DC			
Monitor Current (RC Only)	Nominal*		Limit	
	@ 12 VDC	@ 24 VDC	@ 12 VDC	@ 24 VDC
	3 amp	1.5 amp	12 amp	6 amp
Recommended Fuse	15 amp @ 12 Volt or 7.5 amp @ 24 Volt			
Environmental Rating	All components desinged to meet minimum rating or NEMA 4 (IP65)			

### 3.2 CORROSION

The valve body is hard anodized and powder coated to help prevent corrosion. Galvanic corrosion due to dissimilar metals can be prevented by using flange isolation kits. Where practical, the standpipe should be drained while not in use to eliminate a path of conduction.

### 3.3 USE WITH SALT WATER

Use with salt water is permissible provided valve is thoroughly cleaned with fresh water after each use. The service life of the valve may be shortened due to the effects of corrosion and is not covered under warranty.

### 3.4 PARTS IDENTIFICATION AND INTENDED ORIENTATION

Figures 1 and 2 identify terms that describe the various parts and controls of the valve. The parts in the IVUM RC of figure 2 are identical to figure 1 except as noted. When installed in the orientation shown, the external automatic drain valve will allow the valve and monitor to drain fully after use. An optional internal automatic drain valve allows the standpipe to drain even while the valve is closed. See section 5.5 DRAINING RESIDUAL WATER.

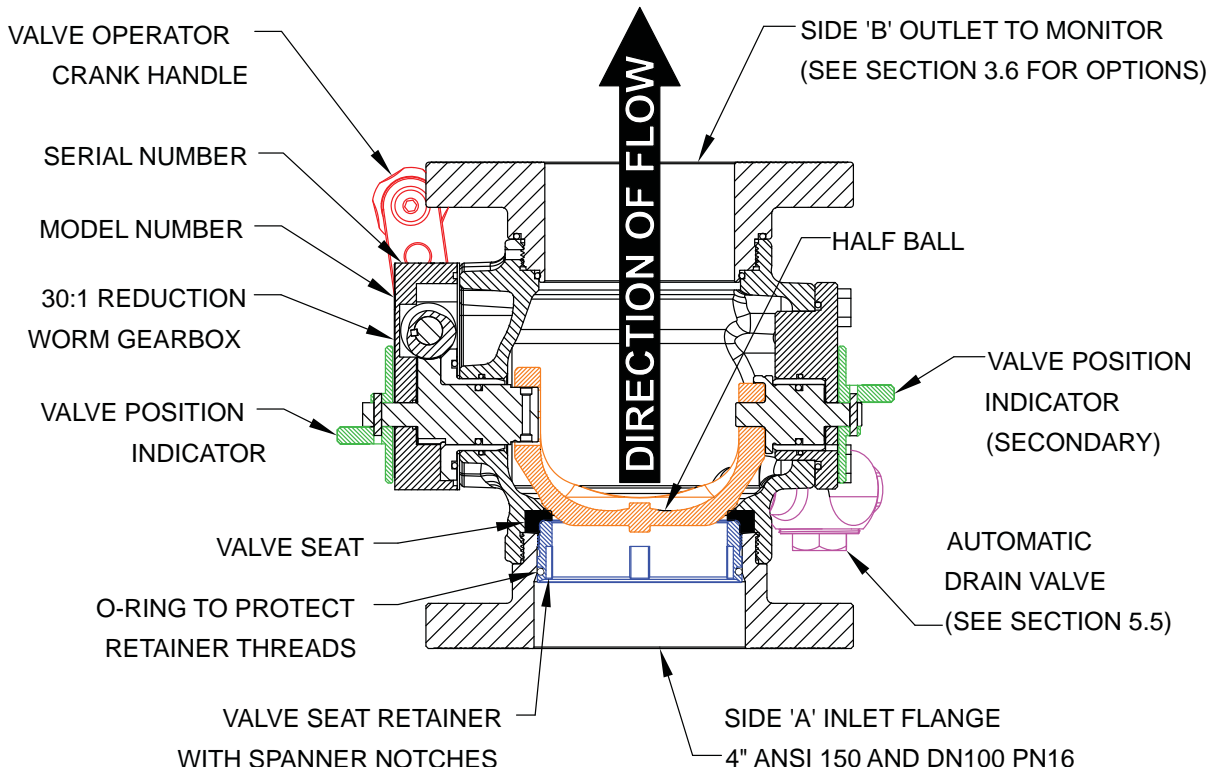

Figure 1: IVUM Parts Identification

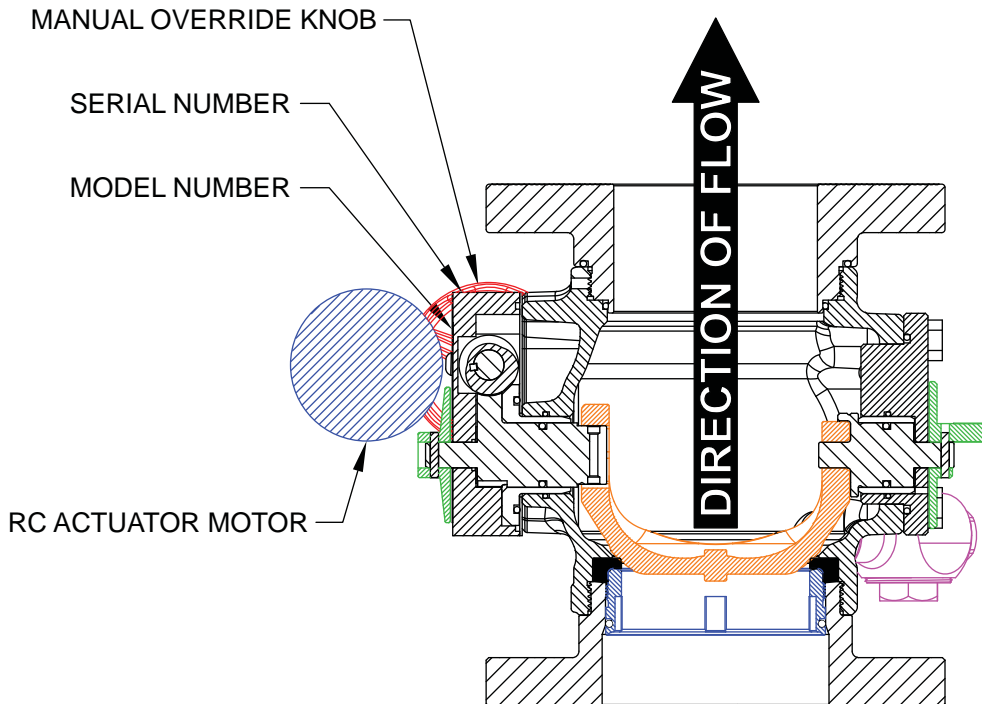

Figure 2: IVUM RC Parts Identification

### 3.5 OVERALL DIMENSIONS AND WEIGHTS

The overall height and weight of the IVUM vary according to the side 'A' inlet material and choice of side 'B' outlet to monitor. See figure 3 and table 3 below for the IVUM, and figure 4 and table 4 on the following page for the IVUM RC. The overall height and weight can be calculated by adding the values for the appropriate options shown in section 3.5 and section 3.6.

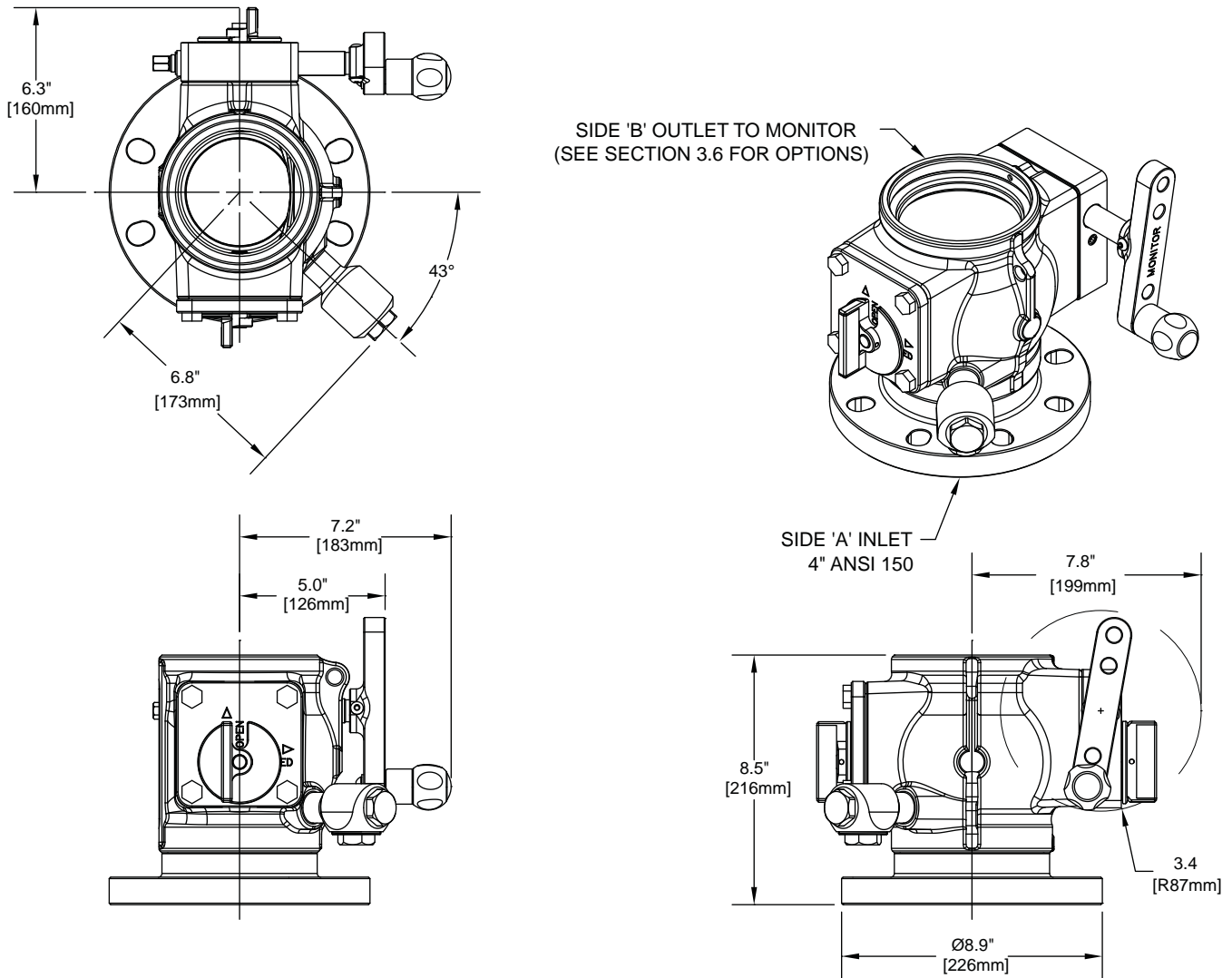

Figure 3: IVUM dimensions without monitor outlet

MODEL	SIDE 'A' Option for Flange, Seat Retainer and Half Ball	WEIGHT – lb (kg)
ZAAD*	Hard anodized Aluminum with internal drain in half ball	18.3 (8.3)
ZAAZ*	Hard anodized Aluminum without drain in half ball	18.3 (8.3)
ZASD*	316 Stainless Steel with internal drain in half ball	29.6 (13.4)
ZASZ*	316 Stainless Steel without drain in half ball	29.6 (13.4)

Table 3: IVUM weight without monitor outlet

Third character of model number signifies inlet material ('A' for aluminum; 'S' for stainless steel).  
 Fourth character of model number signifies the internal drain option ('D' for drain; 'Z' for no drain).  
 All models come standard with an external automatic drain valve.

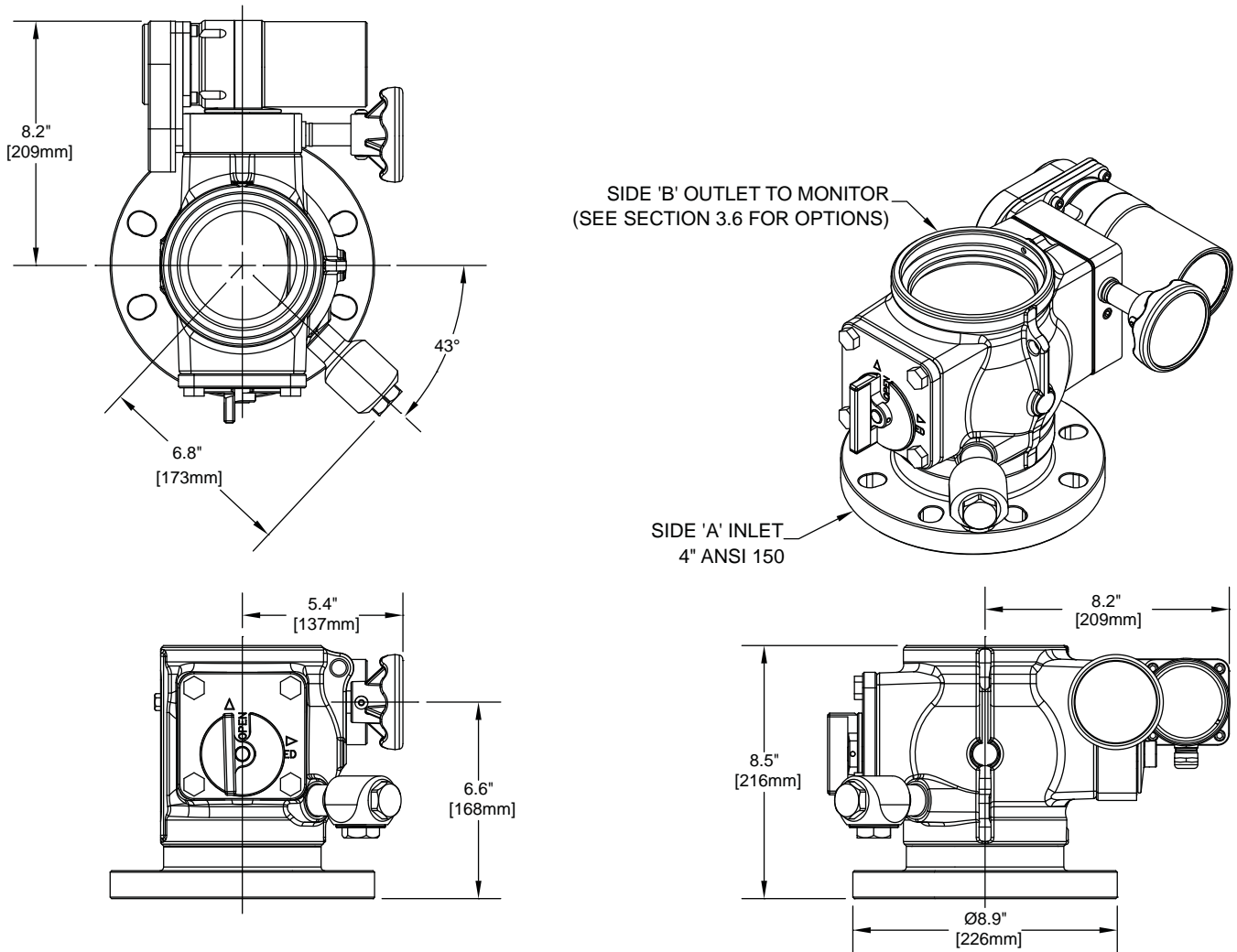

Figure 4: IVUM RC dimensions without monitor outlet

MODEL	SIDE 'A' Option for Flange, Seat Retainer and Half Ball	WEIGHT – lb (kg)
ZAAD*-RC	Hard anodized Aluminum with internal drain in half ball	26.0 (11.8)
ZAAZ*-RC	Hard anodized Aluminum without drain in half ball	26.0 (11.8)
ZASD*-RC	316 Stainless Steel with internal drain in half ball	37.3 (16.9)
ZASZ*-RC	316 Stainless Steel without drain in half ball	37.3 (16.9)

Table 4: IVUM RC weight without monitor outlet

Third character of model number signifies inlet material ('A' for aluminum; 'S' for stainless steel).  
 Fourth character of model number signifies the internal drain option ('D' for drain; 'Z' for no drain).  
 All models come standard with an external automatic drain valve.

### 3.6 SIDE 'B' MONITOR OUTLET OPTIONS

Several options are available for connecting a monitor to the IVUM. Descriptions, weights and linear dimensions of each option are given in table 5 and figure 5.

DESCRIPTION	OPTION	PART NUMBER	WEIGHT lb (kg)	
CODE-RPM direct connection for TFT monitor, STRAIGHT	1	A1026.4	4.0	(1.8)
CODE-RPM direct connection for TFT monitor, ANGLED 22.5°	2	A1040.4	5.0	(2.3)
4" ANSI 150 FLANGE, STRAIGHT	3	A2080	5.4	(2.4)
4" ANSI 150 FLANGE, ANGLED 22.5°	4	A1039.4	9.7	(4.4)
3" ANSI 150 FLANGE, STRAIGHT	5	A2082	4.7	(2.1)
QUICK CONNECT - 4.5"NH (for Monsoon, Typhoon, Hurricane & 90° Elbow)	Q	Y4484.4	4.5	(2.0)
QUICK CONNECT - 2.5"NHM (for Tornado)	T	Y2432A.4	4.3	(1.9)
TORNADO INTEGRATED BASE FOR VUM (built-into Tornado monitors Y2-TV1A and Y2-EV1A only)	V	N/A	2.2	(1.0)
LARGE MONITOR INTEGRATED BASE FOR IVUM (built-in to Monsoon, Typhoon & Hurricane monitor models with 'X' inlet option)	X	N/A	0.0	(0.0)

Table 5: Side "B" Monitor Outlet Options



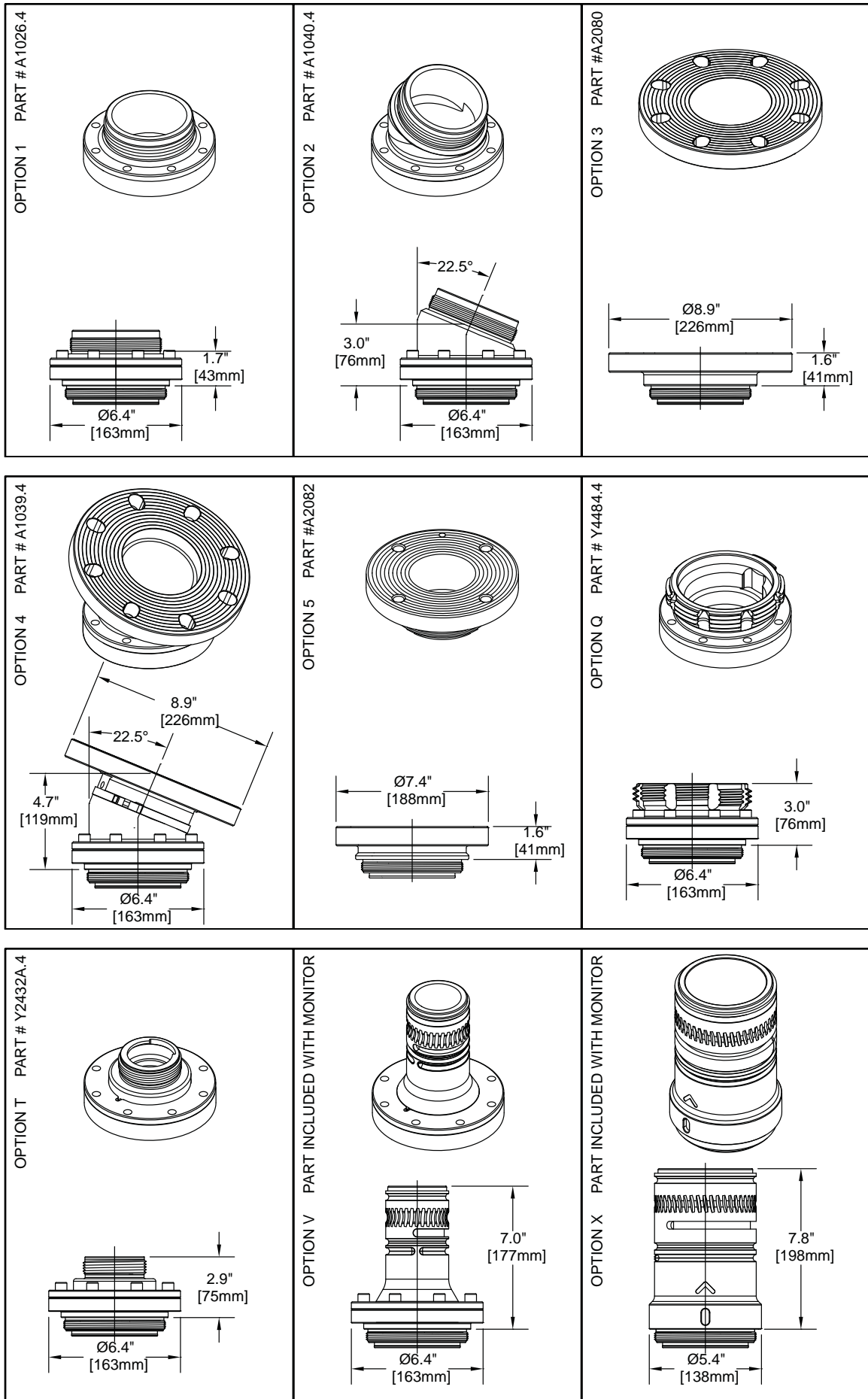

Figure 5: Side "B" Monitor Outlet Options

## 4.0 INSTALLATION

### 4.1 STRUCTURAL REQUIREMENTS FOR PIPE FLANGE MOUNTED MONITORS

#### CAUTION

Dissimilar metals coupled together can cause galvanic corrosion that can result in the inability to unscrew the threads and complete loss of thread engagement over time. If dissimilar metals are left coupled together an anti-corrosive lubricant should be applied to the threads. Also, the coupling should be disconnected and inspected at least quarterly.

#### WARNING

Injury can result from an inadequately supported monitor. The structure to which the Industrial Valve Under Monitor is mounted must be capable of withstanding the internal pressure of the monitor as well as shear and bending forces due to nozzle reaction. Nozzle reaction can be as high as 1500 lbs (680 kg) (2000 gpm at 200 psi, 1600 gpm at 300 psi). Flanges and pipe made from plastic are inadequate for valve mounting and must not be used. This valve is not intended for portable use.

This section pertains to bolting the valve to the standpipe, as well as bolting the monitor to the valve for SIDE B options 3, 4, V and W. The use of flat flanges without raised faces is recommended. Use a ring gasket as defined in ASME 16.21 or ISO 7483. Tighten flange bolts in an alternating sequence as shown in figure 6. For 4" ANSI 150 connection with 5/8-11 bolts or studs, tighten to 76-80 ft-lb (100-110 Newton-meters). See section 4.2 for SIDE B instructions and torque requirements. Tighten sequentially each bolt or stud three times with 30%, then 60%, and finally 100% of the specified torque.

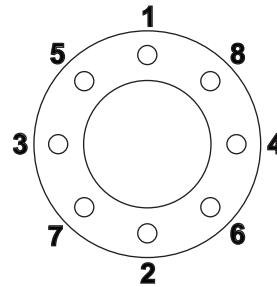

Figure 6: Flange Bolt Tightening Sequence

### 4.2 MONITOR INSTALLATION

#### WARNING

Keep monitor discharge height within acceptable limits. Injury can result from the reaction forces when the monitor discharge height is more than 18.6" (472 mm) from the valve outlet. Avoid use of exceptionally tall monitors, accessories between valve and monitor, or telescopic waterways such as the Task Force Tips Extend-A-Gun which exceed the acceptable monitor discharge height.

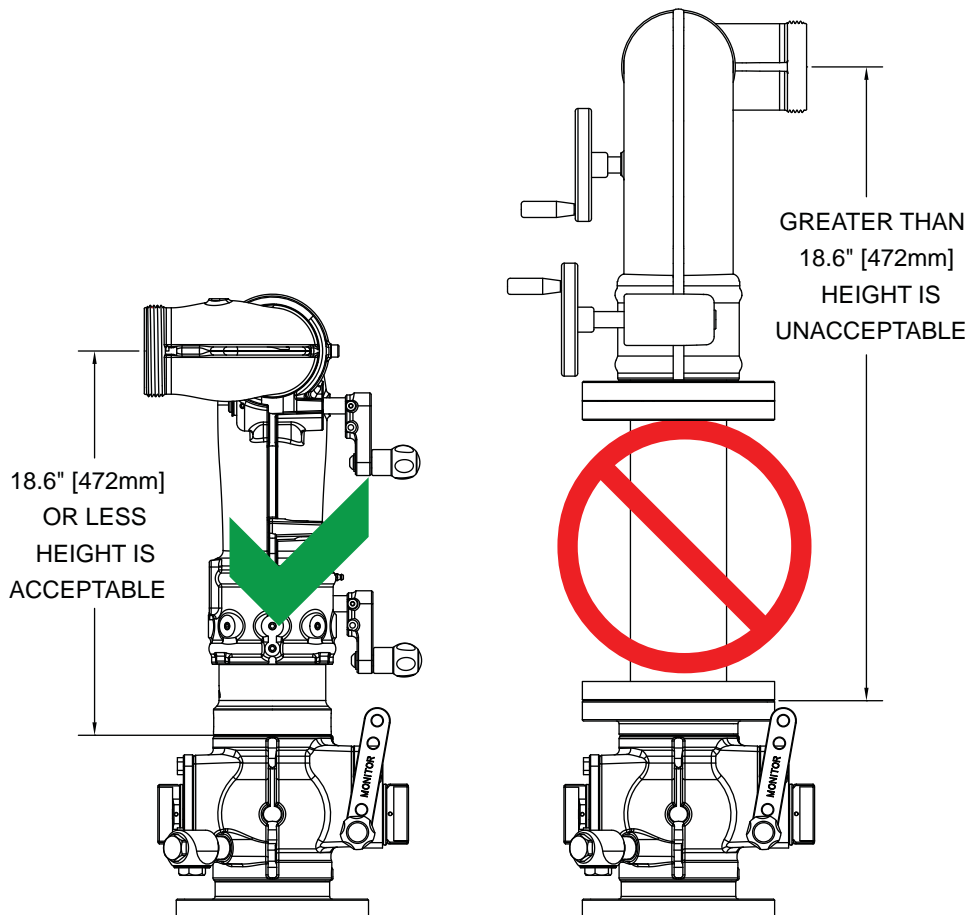

Figure 7: Acceptable Monitor Height

#### 4.2.1 SIDE 'B' OPTIONS 3, 4, V – FLANGED MONITORS

Install monitor on valve using the alternating bolt tightening sequence shown in figure 6.

1. For options 3 and 4, install a ring gasket and tighten 5/8-11 bolts or studs to 76-80 ft-lb (100-110 N-m).
2. For options V, install an o-ring on barb protruding from bottom of flange and apply silicone grease over o-ring. Align as desired, then draw o-ring into valve body by partially tightening alternate bolts.
3. For option V - Tornado monitor, torque 3/8-16 x 1.0" long bolts to 180 to 200 in-lb (15-17 ft-lb; 20-23 N-m).

#### 4.2.2 SIDE 'B' OPTION X – INTEGRATED MONITORS

Refer to figure 8 below.

1. Apply silicone grease to barb and male threads on monitor base. Slide O-ring over barb, then apply silicone grease over the O-ring.
2. Apply silicone grease to face seal groove near thread, then install O-ring into groove. Apply silicone grease over the O-ring.
3. Install monitor on valve and tighten with spanner wrench until the joint is bottomed out, then loosen until one of the milled pockets in the male thread is lined up with the screw hole in the valve body.
4. Apply Loctite 242 (blue) to 1/4-20 x 1/2" long cup point set screw. Tighten screw into pocket in male thread until screw head is snug against valve body.

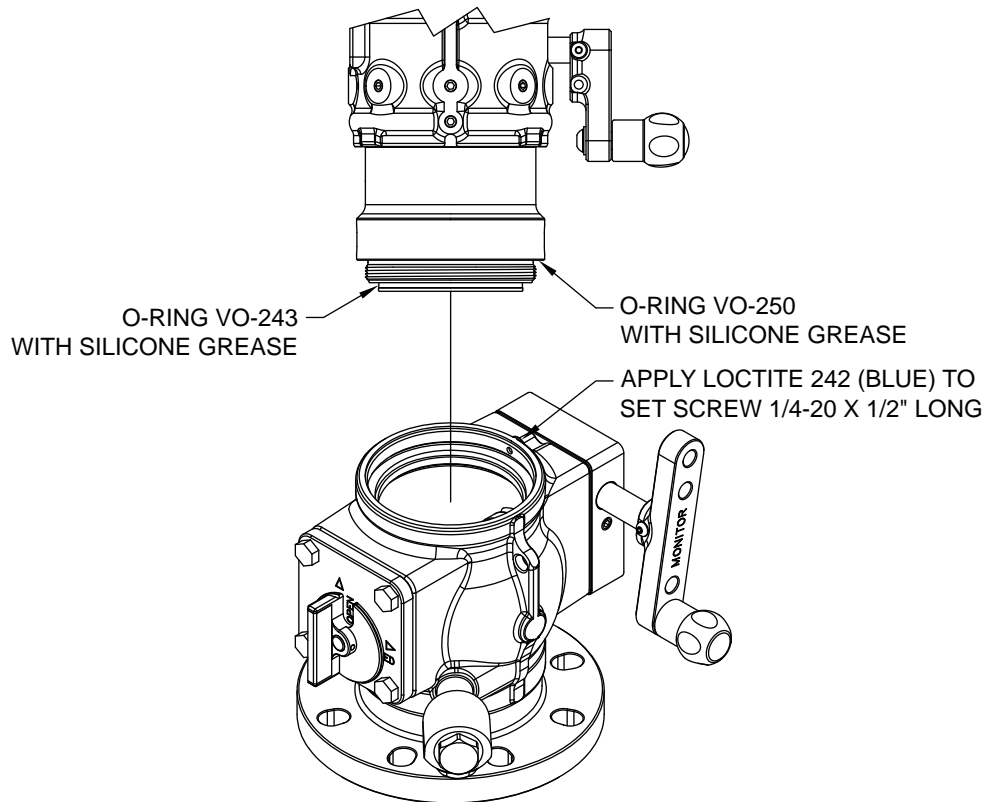

Figure 8: Side 'B' Option X

#### 4.2.3 SIDE 'B' OPTIONS Q and T – QUICK CONNECT FOR MONITORS AND ELBOWS

1. See monitor manuals and quick connect supplement for details (literature numbers LIY-250 and LIY-300).
2. If equipped with locking pin, hold pin out and push coupling up as far as it will go, then release locking pin. This will hold the coupling out of the way while mounting the monitor on the base.
3. Align tongue(s) of female inlet into notches within male threaded outlet. This serves as a rotational lock.
4. Rotate coupling clockwise until threads engage on male threaded outlet, then release locking pin (if so equipped). Continue to rotate coupling until tight. Locking pin will ratchet across detents, but it is not necessary to over-tighten coupling if locking pin ends up between detent positions. To prevent damage, do not use locking pin as a lever to tighten or loosen coupling.

## 4.2.4 SIDE 'B' OPTIONS 1 and 2 – CODE-RPM DIRECT CONNECTION

TWO PIECE CLAMP ROTATIONAL LOCK INSTRUCTIONS (refer to figure 9):

1. Assemble Clamps and place loosely on IVUM outlet.
2. Screw monitor onto VUM until threaded joint bottoms out.
  - CAUTION: Make sure the Clamps are not tight enough to prevent the monitor Base from bottoming out. The monitor will leak if it does not bottom out in this step.
  - Do not use pipe dope or Loctite on the monitor base threads. These threads are sealed with an O-ring. The use of thread locking compounds will make removal difficult.
3. Unscrew monitor until the "Straight Ahead Reference Mark" is facing the desired direction.
  - Monitor may be unscrewed up to one full turn from the bottomed out position.
  - CAUTION: Monitor will leak if unthreaded more than one full rotation from bottomed-out condition.
4. Rotate the Clamps to the desired orientation. Ensure that Clamp assembly does not interfere with RC monitor Power/Com Cable (if applicable).
5. Tighten each Screw gradually until both are finger tight with approximately equal spacing between opposite ends of Clamps.
6. Carefully tighten each Screw one additional turn using a 5/32 hex wrench by alternating to the opposite Screw in half turn increments. CAUTION: Over tightening the Screws will damage Screws and Clamps.

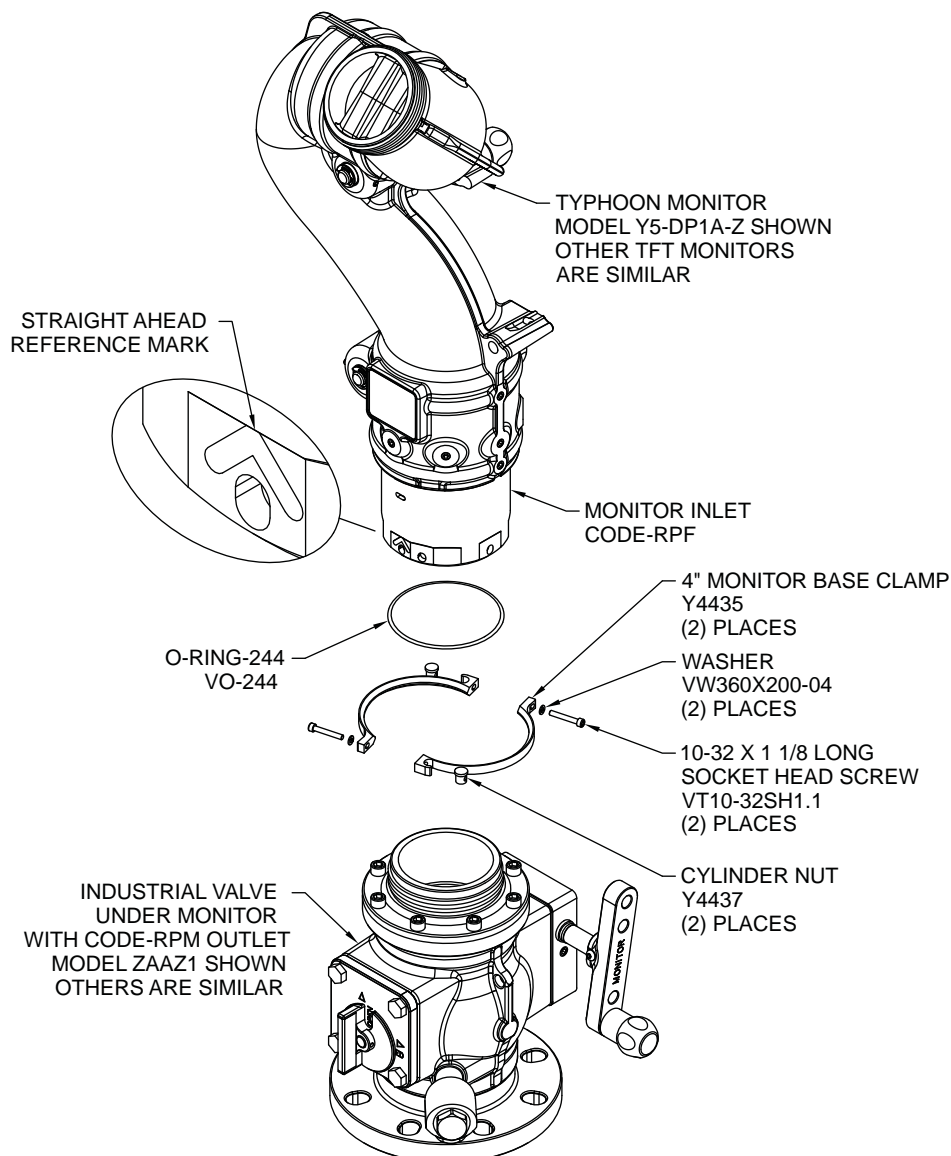

Figure 9: CODE-RPM Direct Connection

### 4.3 ELECTRIC INSTALLATION AND WIRING

Red (+) and black (-) wires of the Valve Interface Box must be connected to a 12 or 24 VDC protected circuit from the power distribution center. To control the valve from a TFT RC monitor operator station, the valve's Blue and White communication wires must be connected to the monitor's blue and white wires as described in section 2.0 of LIY-500 RCE MONITOR ELECTRICAL CONTROLS SUPPLEMENT. Figure 10 shows the IVUM RC typical interface box connections.

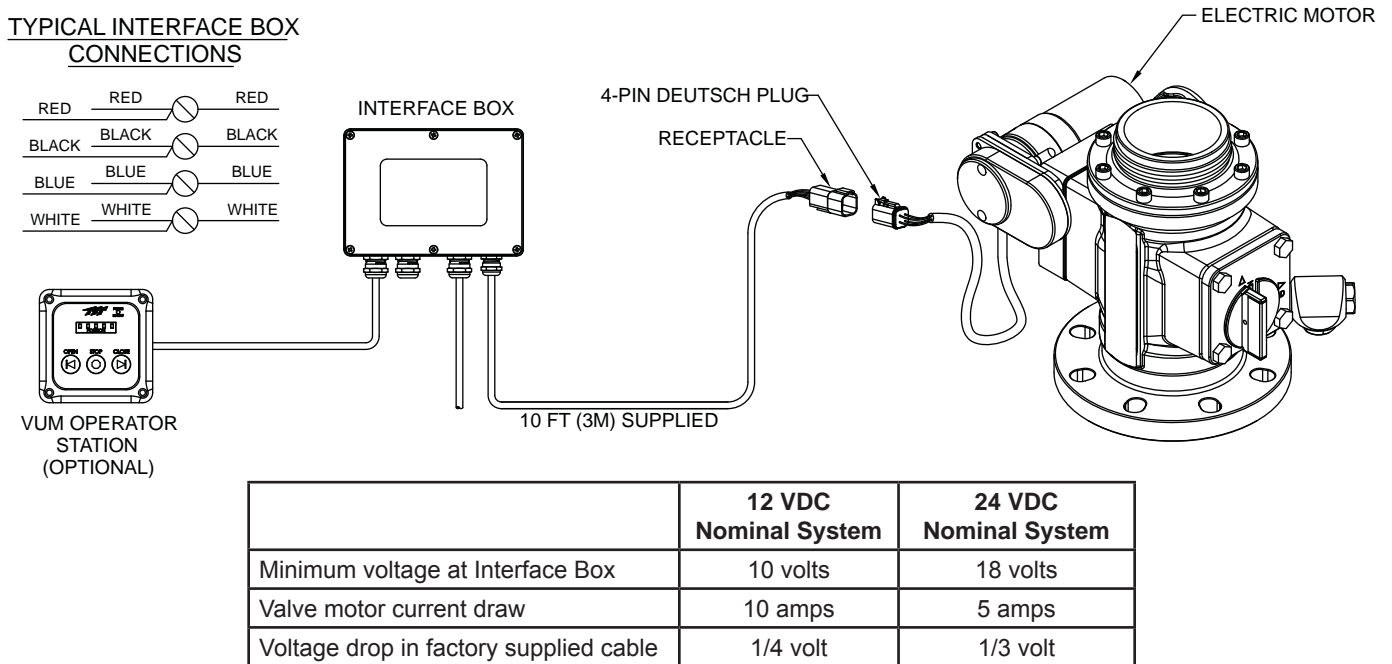

Figure 10: Interface Box Connections

#### NOTICE

Valve control motor may fail to operate if the voltage drop in the cable is excessive. To avoid this situation, do not lengthen the factory supplied motor cable. Power cable selection is critical. Voltage supplied to IVUM Interface Box should not fall below the value listed in figure 10 while valve is in operation.

#### NOTICE

In applications where the only valve control will be from a TFT operator station and no feedback relays are required, it is acceptable to install the RC VUM without the valve interface box. The 4-conductor cable with receptacle can be removed from the interface box. The installer must make appropriate connections to a protected circuit and the monitor communication wires, as described above, in a protected enclosure.

#### NOTICE

Cable is gel filled to prevent moisture wicking into enclosure. Gel is non-hazardous and should be wiped off conductors using a rag.

#### 4.3.1 INTERFACE ENCLOSURE MOUNTING

Select enclosure location. Enclosure is designed to be surface mounted and the size is 4 3/4 x 6 3/4 (120mm x 170mm).

Height of enclosure is 2 1/4" (57mm). Refer to figure 11 for mounting hole dimensions. A full size template is provided in section 11.0.

NOTE: Two tapped holes are provided externally on the back side of the box for purposes of mounting.

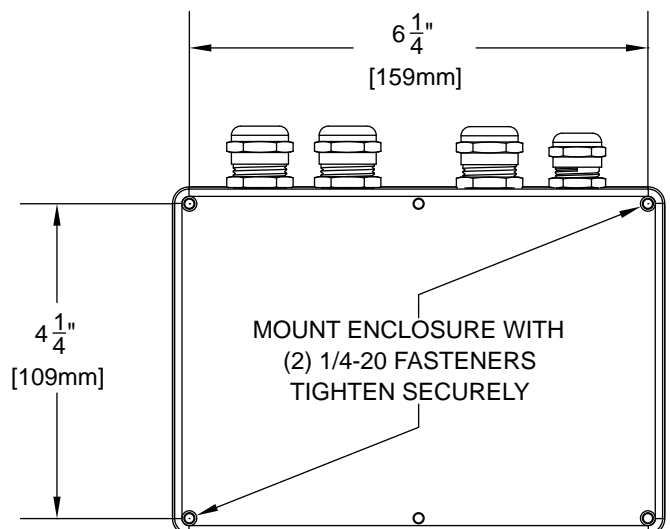

Figure 11: Valve Interface Enclosure Mounting Hole Dimensions

## 4.4 ELECTRICAL TESTING

### NOTICE

The TFT IVUM RC has built in circuit protection to guard against a circumstance where the unit's movement is blocked before reaching its full travel limits. Without this circuitry the motor would stall, overheat, and could be permanently damaged.

When mechanical installation and electrical connections are complete, perform the following test to verify voltage supply is adequate and the current limiting feature is functioning.

1. Apply power to valve controls.
2. Activate Open or Close inputs until valve reaches stop position. Continue to hold button down.
3. Once movement is stopped, manually turn override knob in opposite direction while input is active. If knob can be turned, then voltage supply is adequate. If knob can't be turned and motor continues to operate, then the current limit was not reached because the voltage supply or wiring is below the minimum voltage listed in figure 10.
4. NOTE: Override knob will only turn in one direction.

To ensure proper voltage to the IVUM RC, the wiring needs to be checked for proper gauge for the installed length of wire, and for proper termination. Also, ensure that the power source supplying the IVUM RC and the grounding are adequate (other electrical loads on a shared circuit with the IVUM RC may cause a low-voltage situation). In addition to motor damage, a further consequence of low voltage could be that the valve will not open or close properly or fully.

### SET TRAVEL STOPS

When proper voltage is verified, perform the following to set the full travel limits.

1. Apply power to Valve Controls.
2. Activate CLOSE input until valve is fully closed. Motor must stop by current limit method. If motor continues to operate see proper voltage section above.
3. Activate OPEN input and continue to hold until valve is fully open. Motor must stop by current limit method. If motor continues to operate see proper voltage section above.
4. OPEN/CLOSE input relays will now track valve movement.

## 4.5 INPUTS SIGNAL CONFIGURATION

The Valve Interface box is shipped from the factory configured to accept +12/24 volt DC input signals, but can be field changed to accept ground input signals. To change configuration:

1. Remove lid from box.
2. Locate DIP switches on A5830 board.
3. Slide DIP switch #4 to the OFF position to select GROUND inputs or slide to the ON position to select VOLTAGE input.
4. Replace lid. Verify rubber seal is clean and undamaged. Verify that no wires are caught between lid and box.

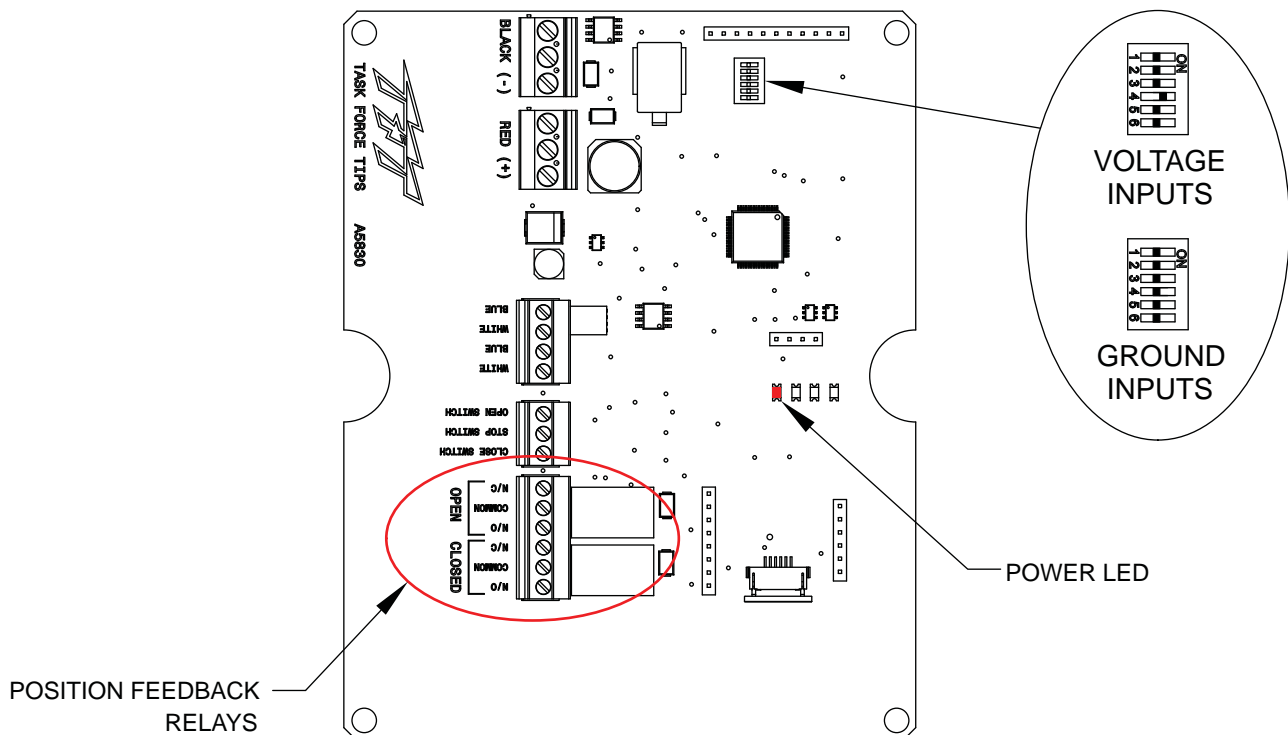

Figure 12: Input signals Configuration

## 4.6 VALVE POSITION FEEDBACK RELAYS

The Valve Interface Box provides position feedback for the user to indicate which position the valve is in. The position relays are energized when the valve is in the corresponding position. The contact rating of the relay is 1 amp @ 30VDC for resistive loads and 0.2 amps @ 30 VDC for inductive loads.

The position relays have one dry Form-C contact (common, normally open, normally closed) that can be used. Figure 12 shows the terminal blocks available for user wiring.

## 4.7 AUX BUTTON OPERATION

The IVUM RC can be operated from any TFT RC Monitor operator station equipped with AUX1/AUX2 buttons. The IVUM RC is factory configured to operate from AUX2 button, but can be changed to operate from AUX1 button. To change follow these steps:

1. Turn off power.
2. Remove retaining ring and cap from back of motor (see section 6.5 index 22 and 23).
3. Slide DIP switch #1 to desired position (see figure 13).
4. Replace cap and retaining ring.
5. Apply Power.

Each IVUM RC is shipped with several button overlays with adhesive that can be attached to any RC monitor operator station with an AUX button. If additional overlays are needed, contact factory.

Clean operator station surface to remove any oils or residues. Carefully peel off overlay and place on top of AUX button, just inside blue border of button as shown in figure 14.

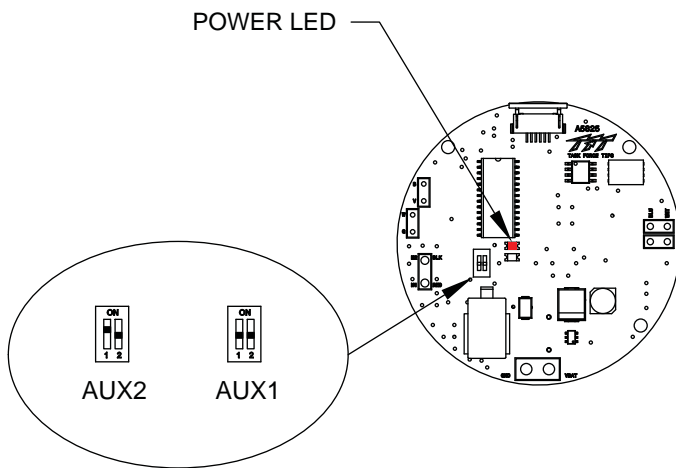

Figure 13: AUX button dip switch settings

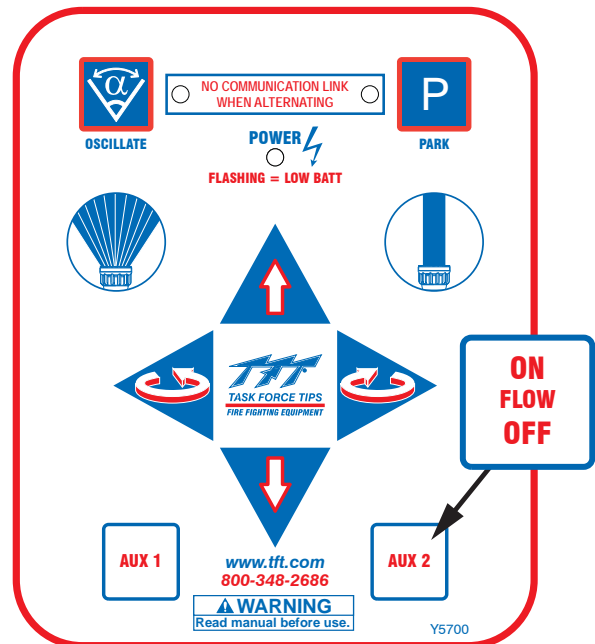

Figure 14: AUX button overlay

## 5.0 USE

### 5.1 OPERATION AND VALVE POSITION INDICATORS

To open the valve, turn the crank handle counter-clockwise until the pointer on the gearbox indicates "OPEN". To close the valve, turn the crank handle clockwise until the pointer indicates "CLOSED". A secondary position indicator is included on the opposite side of the valve to allow 360° verification of valve position. When the valve is open, reflective flags on each indicator are parallel to the direction of flow through the valve. See figure 15.

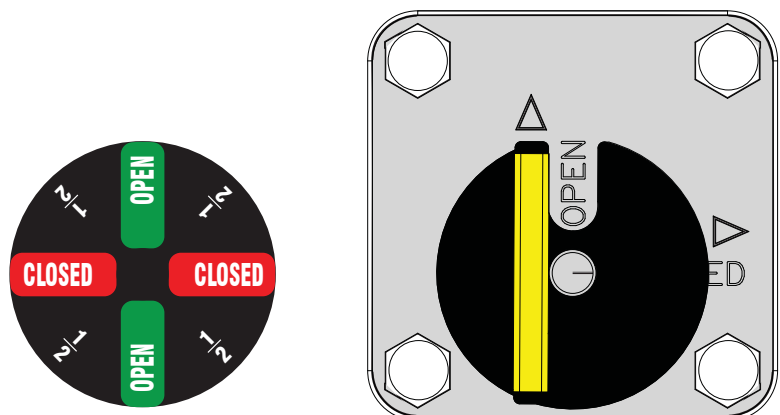

Figure 15: Valve Position Indicators

## 5.2 ELECTRIC REMOTE CONTROL – MANUAL OVERRIDE

The IVUM RC is motor driven but also has an override knob for operating the valve manually. The override knob may also be used in the event of power failure. If electrical power is supplied to the control panel then the LED valve position display will track the valve's position as the knob is moved. If the knob is moved while there is no power to the electric controls than the LED valve position display will be in error when the electric power is reconnected. The LED valve position indicator will self-correct the first time the valve is cycled under electric control.

If more compactness is desired, the override knob may be removed. The drive shaft has a hex so a wrench or socket may be used for manual override. If the manual override knob is removed assure that the correct size wrench is available in the event of power failure.

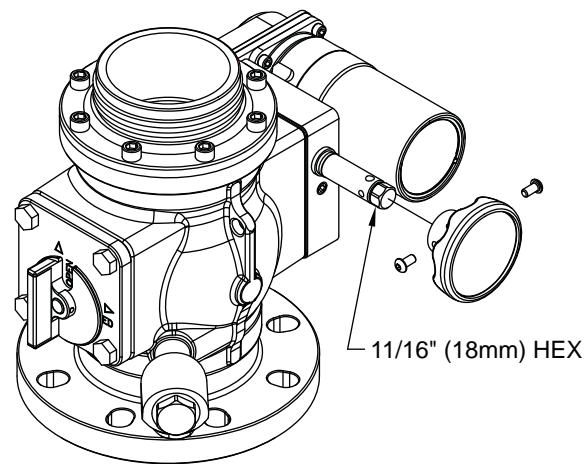

Figure 16: Manual Override

## 5.3 ELECTRIC REMOTE CONTROL OPERATION

### Power LED:

- LED will be solid green when power is present.
- Flashing green LED indicates low voltage.

### Changing Modes (Unit is shipped from factory in the Automatic Mode):

- Activate CLOSE and STOP inputs together for 3 seconds to change to Automatic Mode.
- Activate OPEN and STOP inputs together for 3 seconds to change to Manual Mode.

### Manual Mode – not connected to TFT RC monitor:

- Activating OPEN input will cause valve to open.
- Deactivating OPEN input will cause valve to stop.
- Activating CLOSE input will cause valve to close.
- Deactivating CLOSE input will cause valve to stop.
- STOP input is not applicable in Manual Mode.

### Manual Mode – when connected to TFT RC monitor:

- Activating AUX2 signal or OPEN input will cause valve to open.
- Deactivating AUX2 signal or OPEN input will automatically cause valve to close.

### Automatic Mode – not connected to TFT RC monitor:

- Activating OPEN input (momentarily) will cause valve to travel to full open position.
- Activating CLOSE input (momentarily) will cause valve to travel to full close position.
- Activating STOP input while valve is moving will stop valve.

### Automatic Mode – when connected to TFT RC monitor:

- Activating AUX2 signal will cause full travel. If valve was open, it will move closed and vice-versa.
- Activating AUX2 signal while valve is moving will cause valve to stop momentarily, then reverse direction to full travel.
- Activating OPEN input will cause valve to travel to full open position.
- Activating CLOSE input will cause valve to travel to full close position.
- Activating STOP input while valve is moving will stop valve.

## 5.4 LOCKOUT/TAGOUT

Tether points have been provided on the valve body and both sides of the crank handle to prevent operation of the valve. To minimize the ability to rotate the shaft, tether the nearest end of the crank handle to the valve body with minimal slack.

## 5.5 DRAINING RESIDUAL WATER

### NOTICE

All monitors, valves and standpipes exposed to freezing conditions must be drained immediately following use to prevent damage. To drain a standpipe, a drainage port must be opened underground below the frost depth to keep water out of the standpipe until the next use.



## EXTERNAL DRAIN VALVE

All Industrial VUMs are equipped with an external automatic drain valve attached to a port directly above the valve seat. The drain valve allows the monitor and valve body to drain fully after the half ball is closed, thus minimizing susceptibility to damage from corrosion and freezing water. The drain valve is designed to close automatically when pressure exceeds 5 psi. When pressure drops below 5 psi, the drain valve will open. If the external drain valve becomes damaged to the extent that it leaks excessively, it may be temporarily replaced with a 3/4" NPT plug during monitor operation. Loosen the plug to drain the monitor following use, and replace it with a functional drain valve assembly as soon as possible. The external drain valve is assembled within a two piece housing which threads into the valve body using 3/4" NPT threads. See index numbers 12 through 17 in section 6.1 for a view of the assembly.

## INTERNAL DRAIN VALVE

An optional internal automatic drain valve located within the half ball allows the standpipe to draw atmospheric air to facilitate draining, even while the half ball is closed. It is beneficial in applications where the standpipe will typically be drained following use, especially where freezing conditions are a concern. If the internal drain valve is not included, the half ball must be manually opened and the standpipe drained below the freeze line to protect the equipment from freezing conditions. The internal drain valve is fastened directly to the outside of the half ball. See index numbers 5 through 8 in section 6.2 for a view of assembly.

## USE ON TELESCOPING WATERWAYS (AERIAL APPARATUS)

Specifying the internal automatic drain valve is highly recommended to assist draining and retracting of telescoping waterways. The internal automatic drain valve is only functional after pressure has been relieved from the waterway and will not serve as a pressure relief valve under any circumstances.

After pressure has been relieved, the internal drain valve allows water and atmospheric air to back flow through the monitor and IVUM to drain the waterway, even if the IVUM remains closed. Then, the internal drain valve allows air to vent out to the atmosphere as the waterway is retracted.

If the internal drain valve is not included, then the IVUM must be opened prior to draining and retracting the waterway. Otherwise, damage to the waterway may occur if no other atmospheric vent orifice is present.

## 6.0 VALVE FRICTION LOSS

The flow coefficient and graph below apply to all models of the 4" Industrial Valve Under Monitor. Data shown is for valve only and does not include monitor or nozzle pressure losses.

The Cv flow coefficient is calculated according to the formula :

$$C_v = \frac{Q}{\sqrt{\Delta P}}$$

Where Cv = flow coefficient, Q = flow rate in gpm and ΔP = pressure loss in psi across valve (applies for water only).

For the 4" Industrial Valve under monitor,  $C_v = 815$

$$\Delta P = \frac{Q^2}{C_v^2}$$

To calculate pressure loss for a given flow rate, this formula can be rearranged as:

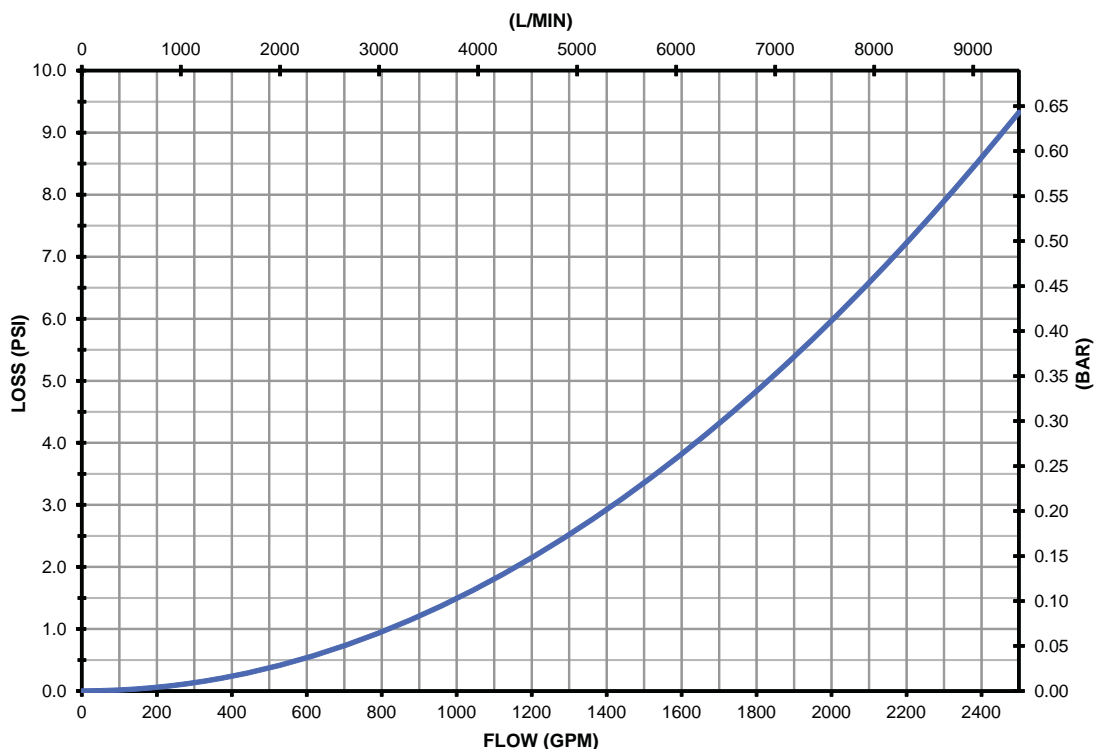

## 7.0 EXPLODED VIEWS AND PARTS LISTS

### 7.1 MAIN VALVE ASSEMBLY EXPLODED VIEW

"Half Ball [A], Secondary Position Indicator [B], Worm Drive Gearbox [C] and RC Motor Assembly [D] are shown on following pages

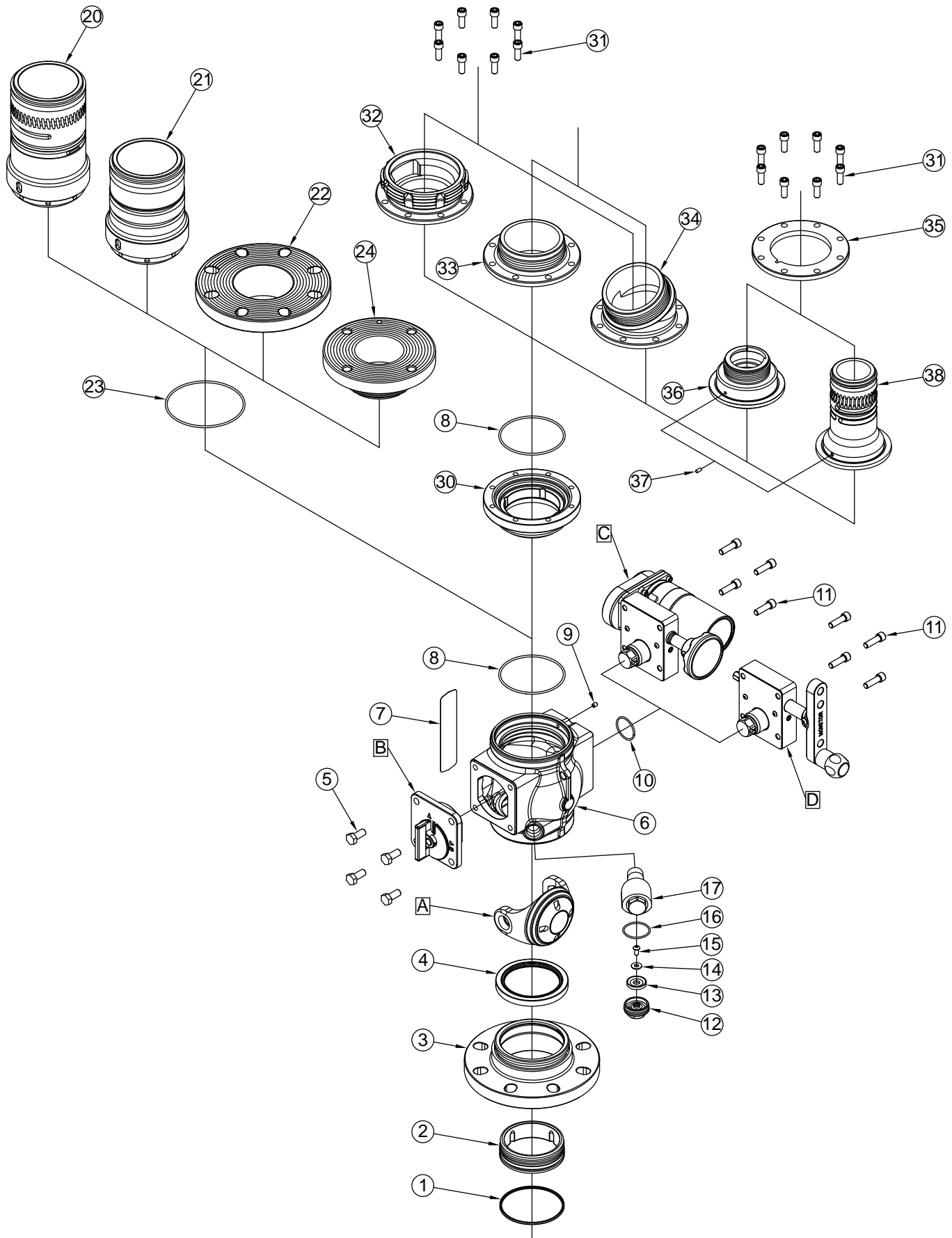

INDEX	DESCRIPTION	QTY	PART #
1	QUAD-RING-242	1	VOQ-4242
2	INNER SEAT RETAINER ALUM	1	A2071A
	INNER SEAT RETAINER STAINLESS		A2071S
3	INLET FLANGE 4"ANSI 150 ALUM	1	A2070A
	INLET FLANGE 4"ANSI 150 STAINLESS		A2070S
4	VALVE SEAT	1	A1520
5	7/16-14 X 1 HEX HEAD BOLT	4	VT43-14HX1.0
6	VALVE BODY IVUM 4"	1	A2002
7	NAME LABEL IVUM 4"	1	A2079
8	O-RING-243	2	VO-243
9	1/4-20 X 1/2 SOCKET SET SCREW CUP POINT	1	VT25-20SS500
10	O-RING-128	1	VO-128
11	3/8-16 X 1 1/4 SOCKET HEAD CAP SCREW	4	VT37-16SH1.2
12	DRAIN HOUSING	1	X375
13	DRAIN VALVE	1	X382
14	FLAT WASHER 1/4"	1	VW687X281-50
15	1/4-20 X 1/2 BUTTON HEAD SCREW	1	VT25-20BH500
16	O-RING-130	1	VO-130
17	DRAIN HOUSING 3/4"NPT MALE	1	ZB1010
20	BASE CODE-RRM ALUMINUM	1	Y4412
21	TILLER BASE CODE-RRM ALUMINUM	1	Y4413
22	FLANGE 4"ANSI X CODE-RRM MODIFIED	1	A2080
23	O-RING-250	1	VO-250
24	FLANGE 3"ANSI X CODE-RRM MODIFIED	1	A2082
30	ADAPTER CODE-RRM X VUM OUTLET	1	A2081
31	3/8-16 X 1 SOCKET HEAD SCREW	8	VT37-16SH1.0
32	QUICK CONNECT - VUM X 4.5"NHM	1	Y4484
33	OUTLET VUM CODE-RPM	1	A1026
34	OUTLET VUM 22.5 DEGREE CODE-RPM	1	A1040
35	FLANGE VUM FOR SMALL MONITORS	1	Y2433
36	QUICK CONNECT - VUM X 2.5"NHM	1	Y2432A
37	3/16 X 3/8 HDP SPIROL PIN	1	VP188X.38HDP
38	BASE SINGLE LEAD FOR VUM	1	Y2416A
A	HALF BALL	1	SEE SECTION 6.2
B	SECONDARY POSITION INDICATOR	1	SEE SECTION 6.3
C	WORM GEARBOX	1	SEE SECTION 6.4
D	RC MOTOR ASSEMBLY	1	SEE SECTION 6.5

## 7.2 HALF BALL [A] EXPLODED VIEWS

MODEL ZAAZ\* -- ALUMINUM  
HALF BALL WITHOUT DRAIN

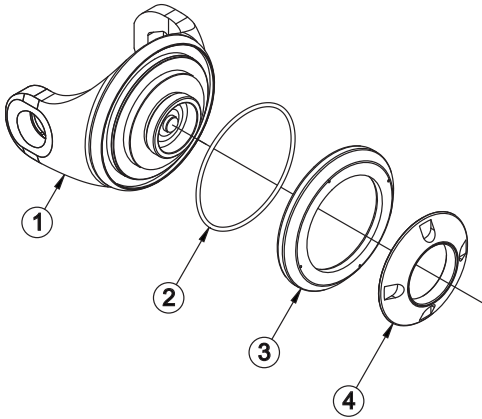

MODEL ZAAD\* -- ALUMINUM  
HALF BALL WITH INTERNAL DRAIN

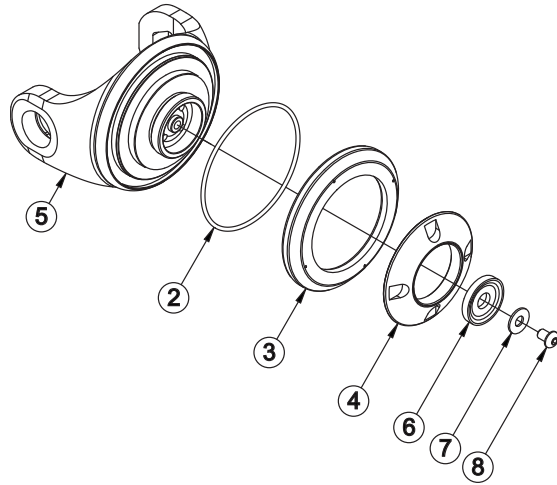

MODEL ZASZ\* -- STAINLESS STEEL  
HALF BALL WITHOUT DRAIN

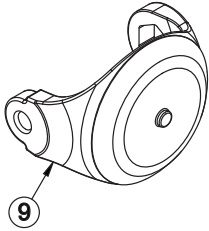

MODEL ZASD\* -- STAINLESS STEEL  
HALF BALL WITH INTERNAL DRAIN

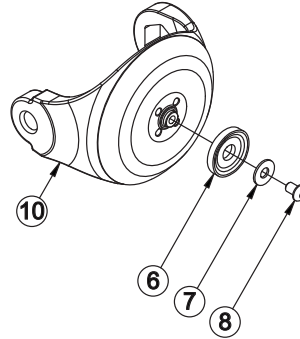

INDEX	DESCRIPTION	QTY	PART #
1	4" HALF BALL ALUM	1	A2090
2	O-RING-237	1	VO-237
3	SPHERICAL SEAT INSERT 4"	1	A2091
4	SPHERICAL SEAT RETAINER 4"	1	A2092
5	4" HALF BALL WITH DRAIN ALUM	1	A2093
6	DRAIN VALVE	1	X382
7	FLAT WASHER 1/4"	1	VW687X281-50
8	1/4-28 X 3/8 BUTTON HEAD SCREW	1	VT25-28BH375
9	HALF BALL 5.5"DIA STAINLESS	1	A1043S
10	HALF BALL SELF-DRAIN 5.5"DIA STAINLESS	1	A1028S

### 7.3 SECONDARY POSITION INDICATOR [B] EXPLODED VIEW

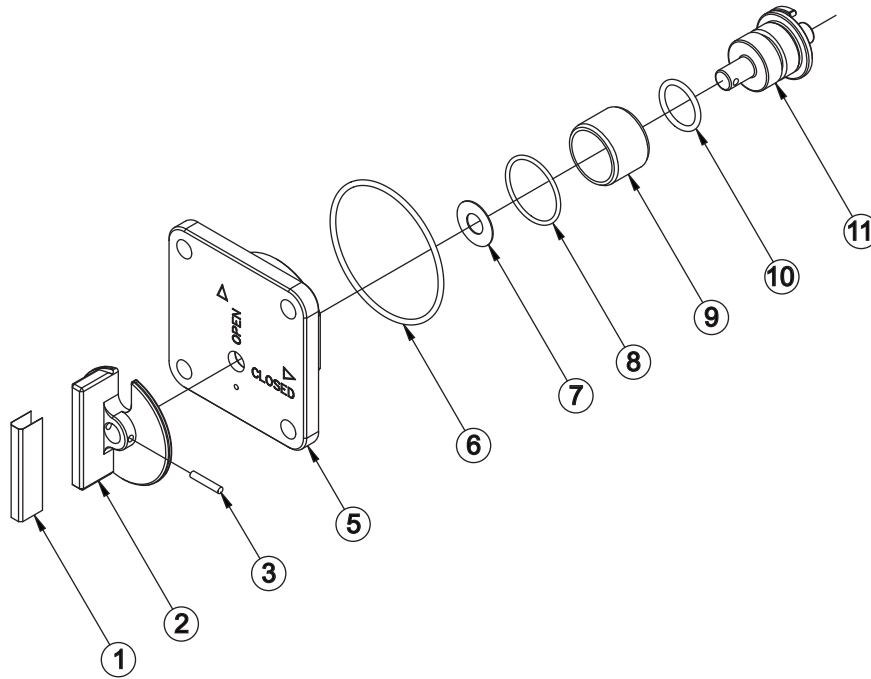

INDEX	DESCRIPTION	QTY	PART #
1	POSITION INDICATOR LABEL	1	A1524
2	POSITION INDICATOR WITH FLAG	1	A1523
3	5/32 X 7/8 HDP SPIROL PIN	1	V1900
5	TRUNNION GUIDE	1	A2075
6	O-RING-236	1	VO-236
7	GEAR THRUST WASHER	1	A1502
8	O-RING-128	1	VO-128
9	LOWER TRUNNION BUSHING	1	A2074
10	O-RING-214	1	VO-214
11	INDICATOR TRUNNION ALUM	1	A2073A
	INDICATOR TRUNNION STAINLESS		A2073S

## 7.4 WORM GEARBOX [C] EXPLODED VIEW

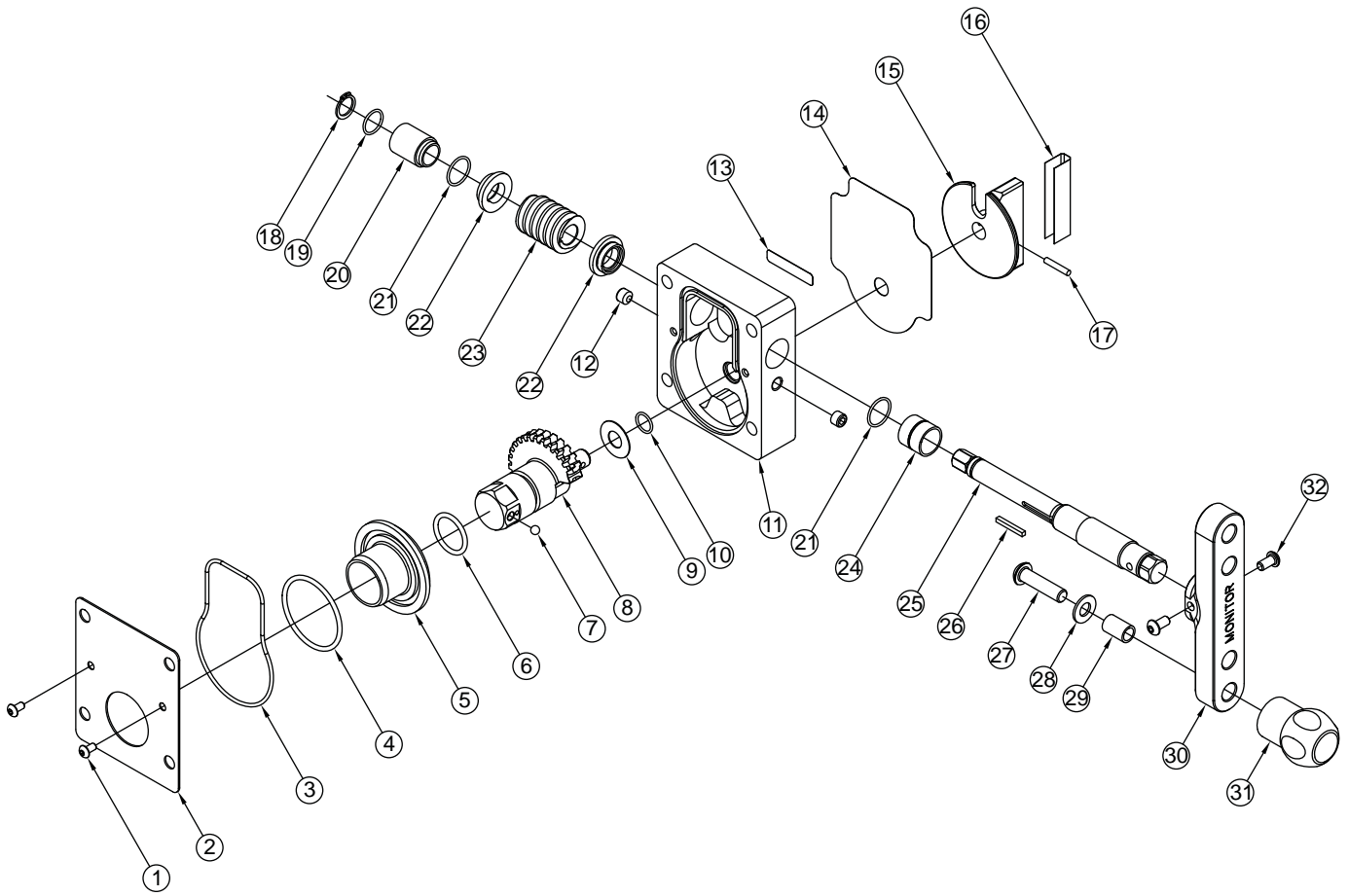

INDEX	DESCRIPTION	QTY	PART #
1	10-24 X 3/8 BUTTON HEAD SCREW	2	VT10-24BH375
2	GEARBOX COVER	1	A1030
3	O-RING-154	1	VO-154
4	O-RING-226	1	VO-226
5	GEAR SPACER	1	A1511
6	O-RING-214	1	VO-214
7	.243" TORLON BALL	1	VB243TO
8	INTEGRAL WORM GEAR & TRUNNION	1	A1501
9	GEAR THRUST WASHER	1	A1502
10	O-RING-014	1	VO-014
11	GEARBOX 250PSI	1	A1506
12	3/8-16 X 5/16 SOCKET SET SCREW	2	VT37-16SS312
13	MODEL NUMBER LABEL	1	A1303
14	NAME LABEL: VUM GEARBOX	1	A1024
15	POSITION INDICATOR	1	A1523
16	POSITION INDICATOR LABEL	1	A1524
17	5/32 X 7/8 HDP SPIROL PIN	1	V1900
18	RETAINING RING	1	VR4275
19	O-RING-016	1	VO-016
20	LARGE BUSHING FOR SEALED GEARBOX	1	A1528
21	O-RING-018	2	VO-018
22	WORM THRUST WASHER	2	A1529
23	12 DP WORM - DEGREASED	1	X220
24	SMALL BUSHING FOR SEALED GEARBOX	1	A1527
25	SHAFT FOR SEALED GEARBOX	1	A1533
26	KEY	1	X225
27	3/8-16 X 1-1/2 BUTTON HEAD SCREW	1	VT37-16BH1.5
28	WASHER	1	VW812X406-65
29	CRANK BUSHING	1	A1547
30	T-HANDLE CRANK	1	A1534
31	KNOB	1	A1512
32	1/4-20 X 1/2 BUTTON HEAD SCREW	2	VT25-20BH500

## 7.5 RC MOTOR ASSEMBLY [D] EXPLODED VIEW

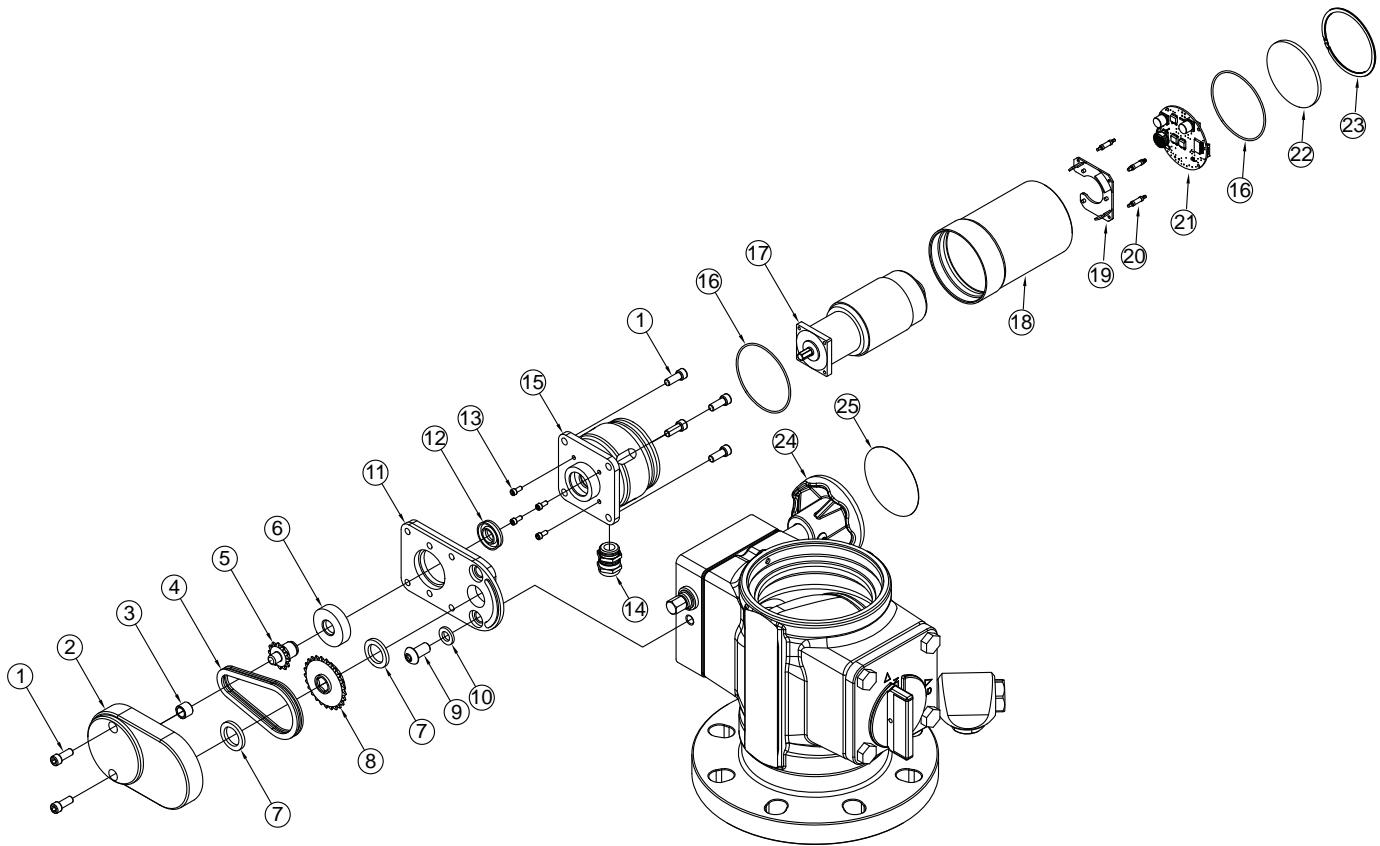

INDEX	DESCRIPTION	QTY	PART #
1	1/4-28 X 5/8 SOCKET HEAD SCREW	6	VT25-28SH625
2	REDUCER COVER	1	A1097
3	BUSHING NYLON 3/8 X 1/2 X 3/8	1	X252
4	38LINK ROLLER CHAIN S.S. - SUBASSEMBLY	1	AX1685
5	DRIVE SPROCKET	1	X253
6	BUSHING MOTOR	1	X256
7	THIN WASHER	2	A1530
8	BIV SPROCKET 25	1	A1098
9	3/8-16 X 3/4 BUTTON HEAD SCREW	1	VT37-16BH750
10	LOCK WASHER 3/8" STAINLESS 18-8	1	VW375SSLOCK
11	REDUCER HOUSING	1	A1096
12	CUP SEAL 1.0625 X .5625 X 1/4	1	Y4620
13	6-32 X 5/16 LONG SHCS WITH HEAD SEAL	4	VT06S32SH312
14	STRAIN RELIEF PG11 .39 HOLE	1	Y5205
15	MOTOR SOCKET	1	Y4615
16	O-RING-038	2	VO-038
17	GEAR MOTOR	1	Y4600
18	MOTOR ENCLOSURE TUBE	1	Y4641
19	MOTOR BOARD SUPPORT	1	Y4643
20	CIRCUIT BOARD STANDOFF	3	Y5538
21	VALVE MOTOR BOARD	1	A5825
22	MOTOR ENCLOSURE CAP	1	Y4642
23	SMALLEY RING	1	V4295
24	KNOB	1	Z245
25	OVERRIDE KNOB LABEL	1	Y4176



## 8.0 TEMPLATES



Hole Location for Enclosure

## 9.0 WARRANTY

Task Force Tips, Inc., 3701 Innovation Way, Valparaiso, Indiana 46383-9327 USA (“TFT”) warrants to the original purchaser of its nozzles and other equipment (“equipment”), and to anyone to whom it is transferred, that the equipment shall be free from defects in material and workmanship during the five (5) year period from the date of purchase.

TFT’s obligation under this warranty is specifically limited to replacing or repairing the equipment (or its parts) which are shown by TFT’s examination to be in a defective condition attributable to TFT. To qualify for this limited warranty, the claimant must return the equipment to TFT, at 3701 Innovation Way, Valparaiso, Indiana 46383-9327 USA, within a reasonable time after discovery of the defect. TFT will examine the equipment. If TFT determines that there is a defect attributable to it, it will correct the problem within a reasonable time. If the equipment is covered by this limited warranty, TFT will assume the expenses of repair.

If any defect attributable to TFT under this limited warranty cannot be reasonably cured by repair or replacement, TFT may elect to refund the purchase price of the equipment, less reasonable depreciation, in complete discharge of its obligations under this limited warranty. If TFT makes this election, claimant shall return the equipment to TFT free and clear of any liens and encumbrances.

This is a limited warranty. The original purchaser of the equipment, any person to whom it is transferred, and any person who is an intended or unintended beneficiary of the equipment, shall not be entitled to recover from TFT any consequential or incidental damages for injury to person and/or property resulting from any defective equipment manufactured or assembled by TFT. It is agreed and understood that the price stated for the equipment is in part consideration for limiting TFT’s liability. Some states or countries do not allow the exclusion or limitation of incidental or consequential damages, so the above may not apply to you.

TFT shall have no obligation under this limited warranty if the equipment is, or has been, misused or neglected (including failure to provide reasonable maintenance) or if there have been accidents to the equipment or if it has been repaired or altered by someone else.

**THIS IS A LIMITED EXPRESS WARRANTY ONLY. TFT EXPRESSLY DISCLAIMS WITH RESPECT TO THE EQUIPMENT ALL IMPLIED WARRANTIES OF MERCHANTABILITY AND ALL IMPLIED WARRANTIES OF FITNESS FOR A PARTICULAR PURPOSE. THERE IS NO WARRANTY OF ANY NATURE MADE BY TFT BEYOND THAT STATED IN THE DOCUMENT.**

This limited warranty gives you specific legal rights, and you may also have other rights which vary from state to state.

## 10.0 MAINTENANCE

The Industrial Valve Under Monitor requires no routine maintenance. The gearbox is sealed and requires no periodic greasing. Valve seats shall be greased as needed with a silicone based grease such as Dow Corning 112. Any scrapes that expose bare aluminum should be cleaned and touched up with enamel pain such as Rust-Oleum. Replace any missing or damaged parts before returning the valve to service.

### 10.1 TROUBLE SHOOTING

SYMPTOM	POSSIBLE CAUSE	REMEDY
Leaks	Debris or damage in seal area	Clean out debris or replace damaged parts
Binding, Erratic operation	Low Voltage (see below)	See Below
Power LED on but no operation	Low voltage due to: -wire gage too small -wire length too long -poor connection -inadequate apparatus electrical system	Check connections and wiring per section 4.3
LED D6 on motor board blinks rapidly when button is pressed	Bad motor encoder	Replace motor sub assembly
No Power LED	Polarity reversed or poor connection	Check wiring and correct polarity
Valve operates from valve control but not from RC monitor operator stations	Incorrect communication wiring	Check blue & white communication wiring

### 10.2 REPAIRS

Factory service is available with repair time seldom exceeding one day in our facility. Factory serviced appliances are repaired by experienced technicians to original specifications, fully tested and promptly returned. Repair charges for non-warranty items are minimal. Any returns should include a note as to the nature of the problem and whom to reach in case of questions.

Repair parts and service procedures are available for those wishing to perform their own repairs. Task Force Tips assumes no liability for damage to equipment or injury to personnel that is a result of user service. Contact the factory or visit the web site at [www.tft.com](http://www.tft.com) for parts lists, exploded views, test procedures and troubleshooting guides.

For additional information on care, maintenance and testing, refer to: NFPA 1962: Standard for the Care, Use, Inspection, Service Testing, and Replacement of Fire Hose, Couplings, Nozzles, and Fire Hose Appliances, 2013 Edition



**Any alterations to the device and its markings could diminish safety and constitute a misuse of this product.**

### 10.3 CRANKSHAFT OVERRIDE AND REPLACEMENT

The crankshaft includes an intentional shear joint to protect the gear train from overload, costly repairs and loss of service. The magnitude of torque required to shear the crankshaft is several times greater than the torque typically needed to operate the valve at maximum operating pressure. If the crankshaft breaks during use, this is an indication that either there is something obstructing the half ball internally or the crank shaft has been abused (e.g. used as a step for climbing).

#### VERRIDE

In an emergency, the side of the crankshaft opposite the hand crank or knob can be turned using a 1/2" wrench or hex socket. This allows the valve to be open or closed until the crankshaft is replaced. To prevent loss of the 1/8" square key on the crankshaft, do not allow the crankshaft to slide out of gearbox until a replacement crankshaft is acquired. It is important not to rely on this as a long-term method of operation.

## DIAGNOSIS

To diagnose the problem that caused the crankshaft to fail, complete the following steps:

1. Close upstream water supply. If possible, relieve pressure leading up to valve.
2. Locate 1/2" hex where crankshaft protrudes from opposite side of gearbox. For IVUM RC models, it will be necessary to remove the chain cover using a 3/16" Allen wrench, then remove the chain and sprockets (index 1 through 8 in section 6.5).
3. Gently turn crank shaft away from travel stop using a 1/2" hex wrench. Do not attempt to shock crankshaft free and do not exceed 50 ft-lb (68 Nm) of torque.
4. If crankshaft will not rotate, then half ball is likely obstructed. Only after relieving pressure on flanged joint, unbolt valve. Clear any obstructions and evaluate whether repair is needed before returning to service.
5. If crankshaft is able to rotate, cycle the valve several times from open to closed to determine whether the crankshaft binds at any place between the travel stops. If crankshaft binds, consult Task Force Tips Service Department to determine the appropriate repairs.
6. If crankshaft rotates freely after clearing any obstructions, then a replacement crank shaft may be ordered from Task Force Tips and replaced as described below.

## REPLACEMENT

A broken crankshaft can be replaced at any time by completing the following steps, regardless of whether or not the upstream water supply is pressurized. Referring to index numbers shown in section 6.4 follow the steps below:

1. Remove external retaining ring (index 16) adjacent to 1/2" hex on crankshaft.
2. Using a punch or Phillips head screwdriver at least 6" in length, gently push on dimple in 1/2" hex end of crankshaft (index 23). Continue to push crankshaft through until it protrudes from opposite side of gearbox.
3. Grab broken end of crankshaft and pull out of gearbox. As crankshaft is withdrawn, grasp small key (index 24) on shaft so it does not get lost.
4. If 1/8" square x 1" long key is not visible in shaft, it has likely fallen into gearbox bore and must be removed before installing new crankshaft. If square key is visible in gearbox bore, slide it out of bore. Needle-nose pliers may be helpful depending on position of key in bore.
5. Verify polymer bushings (index 22 and 18) are still seated in bores on each side of gearbox. If not, locate and replace bushings.
6. Look through gearbox bore and note approximate orientation of square keyway in worm (index 21). Verify round notch in thrust washer (index 20) is aligned with square keyway in worm.
7. Prepare new crankshaft by applying small dab of grease to keyway and seating 1/8" square x 1" long key into keyway. Grease will keep key in place during assembly.
8. Slide shaft into gearbox with key orientation the same as keyway in worm. Rotate shaft slightly in alternating directions until keyway, then push shaft in until it stops. Retaining ring groove and 1/2" hex should be protruding through opposite side of gearbox. If hex is not visible, it may be necessary to slide polymer bushing back into gearbox bore.
9. Install retaining ring (index 16) onto shaft. Do not over-expand the retaining ring.

## 10.4 VALVE SEAT REPLACEMENT

The valve seat may be replaced in the field if it becomes a source of leakage due to harsh environmental conditions or excessive age. A 1/2" drive spanner wrench for the valve seat retainer may be purchased from Task Force Tips.

Referring to index numbers shown in section 6.1 follow the steps below:

1. Close upstream water supply and relieve pressure leading up to valve.
2. After relieving pressure on the inlet flanged joint, unbolt inlet flange of valve).
3. Using 1/2" drive spanner wrench, remove valve seat retainer (index 2). Remove O-ring (index 1) from valve seat retainer.
4. Using pliers, pull old valve seat (index 4) out of groove in valve body.
5. Clean sealing surfaces of half ball (index A), valve body (index 6), flange (index 3) and valve seat retainer. Also clean all debris from threads of valve seat retainer and flange. Verify all sealing surfaces are smooth and intact. If significant damage is visible, consult Task Force Tips Service Department.
6. Apply light coat of silicone based grease such as Dow Corning 112 to all sealing surfaces and threads of half ball, valve body, and valve seat retainer. Open valve so half ball is out of the way.
7. Install new valve seat (index 4) into groove in valve body with wider side facing the half ball. Slide a pick laterally between female thread and valve seat to verify entire circumference of valve seat is seated in groove.
8. Install new O-ring (index 1) over valve seat retainer. Apply grease over O-ring.
9. Install valve seat retainer into flange until it is snug against the valve seat.
10. Reinstall valve on flange according to instructions in section 4.0. If valve leaks through valve seat, try tightening the valve seat retainer slightly more.

## 11.0 ANSWERS TO YOUR QUESTIONS

We appreciate the opportunity of serving you and making your job easier. If you have any problems or questions, our toll-free "Hydraulics Hotline", 800-348-2686, is normally available to you 24 hours a day, 7 days a week.

## 12.0 INSPECTION CHECKLIST

### BEFORE EACH USE, appliances must be inspected to this checklist:

- All valves open and close fully and smoothly
- Waterway is clear of obstructions
- There is no damage to any thread or other connection
- All locks and hold-down devices work properly
- The pressure setting on the relief valve (if so equipped) is set correctly
- Gaskets are in good repair
- There is no obvious damage such as missing, broken or loose parts
- There is no damage to the appliance that could impair safe operation (e.g. dents, cracks, corrosion or other defects)
- All swiveling elements rotate freely
- There are no missing, worn out or broken lugs on couplings
- Hose is securely attached

### BEFORE BEING PLACED BACK IN SERVICE, appliances must be inspected to this list:

- All valves open and close smoothly and fully.
- The waterway is clear of obstructions.
- There is no damage to any thread or other type connection.
- The pressure setting of the relief valve, if any, is set correctly.
- All locks and hold-down devices work properly.
- Internal gaskets are in accordance with NFPA 1962 (2013) Section 7.2.
- There is no damage to the appliance that could impair safe operation (e.g. dents, cracks, corrosion or other defects)
- All swiveling connections rotate freely.
- There are no missing parts or components.
- The marking for maximum operating pressure is visible.
- There are no missing, broken, or worn lugs on couplings.

NFPA 1962: Standard for the care, use, inspection, service testing, and replacement of fire hose, couplings, nozzles and fire hose appliances. (2013 ed., Section 6.2.1). Quincy, MA: National Fire Protection Agency



**Any appliance failing any part of the inspection checklist is unsafe and must have the problem corrected before use. Operating an appliance that fails any of the above inspections is a misuse of this equipment.**