



MANUAL: MASTER FOAM FIXED GPM SELF-EDUCTING FOAM NOZZLE

INSTRUCTIONS FOR SAFE OPERATION AND MAINTENANCE

This instruction manual is intended to familiarize firefighters and maintenance personnel with the operation, servicing, and safety procedures associated with the MASTER FOAM self-educing nozzle.

This manual should be kept available to all operating and maintenance personnel.

WARNING

Read instruction manual before use. Operation of this device without understanding the manual and receiving proper training is a misuse of this equipment. A person who has not read and understood all operating and safety instructions is not qualified to operate the MASTER FOAM self-educing nozzle.

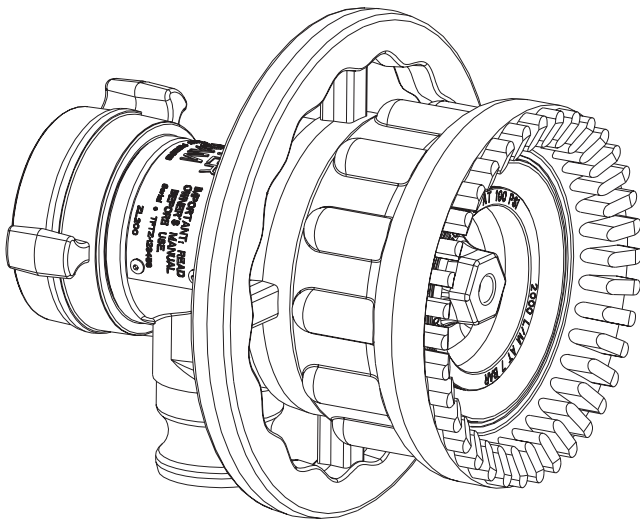

Fixed Flow Rate:
350, 500, or 750 GPM

Nominal Pressure:
100 PSI

**Nominal Foam
Percentages:**
0.5%, 1%, 3%, or 6%

DANGER

PERSONAL RESPONSIBILITY CODE

The member companies of FEMSA that provide emergency response equipment and services want responders to know and understand the following:

1. Firefighting and Emergency Response are inherently dangerous activities requiring proper training in their hazards and the use of extreme caution at all times.
2. It is your responsibility to read and understand any user's instructions, including purpose and limitations, provided with any piece of equipment you may be called upon to use.
3. It is your responsibility to know that you have been properly trained in Firefighting and /or Emergency Response and in the use, precautions, and care of any equipment you may be called upon to use.
4. It is your responsibility to be in proper physical condition and to maintain the personal skill level required to operate any equipment you may be called upon to use.
5. It is your responsibility to know that your equipment is in operable condition and has been maintained in accordance with the manufacturer's instructions.
6. Failure to follow these guidelines may result in death, burns or other severe injury.



Fire and Emergency Manufacturers and Services Association, Inc.
P.O. Box 147, Lynnfield, MA 01940 • www.FEMSA.org

TASK FORCE TIPS, INC.
Made in U.S.A. • www.tft.com

2800 E Evans Ave, Valparaiso, IN 46383-6940 USA
800-348-2686 • 219-462-6161 • Fax 219-464-7155

TABLE OF CONTENTS

1.0 GENERAL INFORMATION

1.1 PART IDENTIFICATION

2.0 NOZZLE OPERATION

2.1 NOZZLE COUPLING

2.2 FLOW CHARACTERISTICS

2.3 PATTERN CONTROL

2.4 FLUSHING DEBRIS

2.5 USE OF FOAM

2.5.1 FOAM SELECTION

2.5.2 SETTING FOAM PERCENTAGE

2.5.3 HOSE CONNECTION

2.5.4 USE OF FOAMJET LX

2.5.5 CLEANING AFTER USE

2.5.6 USE WITH SALT WATER

3.0 MAINTENANCE AND INSPECTION

4.0 EXPLODED VIEW AND PARTS LIST

5.0 WARRANTY

1.0 GENERAL INFORMATION

The Task Force Tips MASTER FOAM nozzle is a simple and rugged self-educing foam nozzle with superior stream quality and reach. This fixed orifice fog nozzle rated at 100 PSI is available with a flow range of 350, 500 or 750 GPM. Fog angle is user adjustable between 90 degree wide fog and straight stream. The nozzle's baffle is removable for flushing debris. The standard swivel coupling is 2.5" NH, NPSH or BSP female threads. The MASTER FOAM Nozzle can educt foam concentrates at 0.5%, 1%, 3% and 6%. Percentage is set by means of an interchangeable orifice plate. The nozzle comes with an 8 foot long 1.5" diameter concentrate hose with a 1.5" camlock fitting (military standard MS27019) for attachment to the nozzle. The simple and basic design requires no grease or other maintenance. The halo ring/stream shaper is made from a non-corroding high temperature polymer. The rubber bumper is UV resistant. The MASTER FOAM self-educing nozzle is hardcoat anodized ANSI 356-T6 aluminum. All MASTER FOAM nozzles accept the FJ-LX-M FoamJet low expansion air-aspirating attachment.

1.1 PART IDENTIFICATION

Figure 1.1 shows the MASTER FOAM nozzle and identifies the various parts and controls.

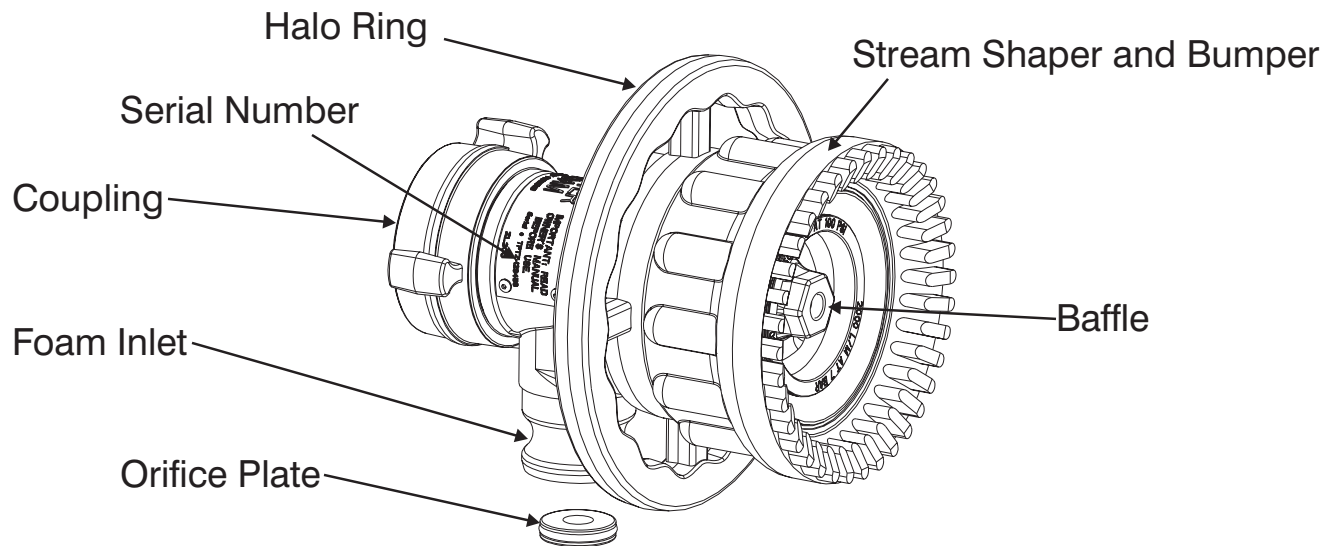

Fig 1.1 Master Foam Nozzle Parts

2.0 NOZZLE OPERATION

2.1 NOZZLE COUPLING

The MASTER FOAM nozzle is available with 2.5 inch female threads (NH, NPSH or BSP). When tightening the coupling, make sure the foam inlet is pointing downward for ease of attaching the concentrate inlet hose.



Nozzle threads must be mated correctly. Mismatched or damaged threads may cause nozzle to leak or uncouple under pressure and could cause injury.



Do not couple aluminum to brass. Dissimilar metals coupled together can cause galvanic corrosion that can result in inability to unscrew the threads or complete loss of thread engagement.

2.2 FLOW CHARACTERISTICS

Figure 2.1 gives the flow characteristics of the MASTER FOAM nozzle. Pressure on the graph is the nozzle inlet pressure. Losses through piping and monitor must be taken into account to deliver the desired pressure to the nozzle. Flow on the graph is the water flow entering the nozzle. Any foam educted will add to this flow.



An inadequate supply of nozzle pressure and/or flow will cause an ineffective stream and can result in injury, death or loss of property. See flow graph or call 800-348-2686 for assistance.

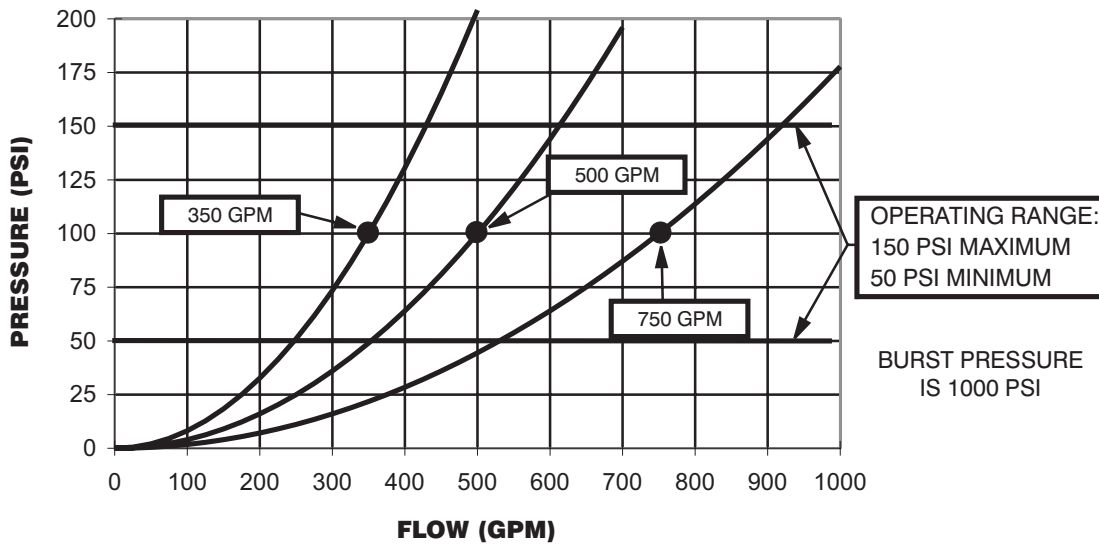

Fig 2.1 MASTER FOAM Flows

2.3 PATTERN CONTROL

The MASTER FOAM's spray pattern is adjustable from straight stream to a 90 degree wide fog. Turning the stream shaper clockwise (as seen from the operating position behind the nozzle -see figure 2.3) moves the shaper to the straight stream position. Turning the shaper counterclockwise will result in an increasingly wider pattern. Only 90 degrees of rotation is required to go from wide fog to straight stream.

Since the stream trim point varies with flow, the stream should be "trimmed" after establishing a steady flow. To properly trim the stream, first open to a narrow fog. Then close the stream to parallel to give maximum reach. NOTE: Turning the shaper further forward will cause stream crossover and reduce the reach of the nozzle.

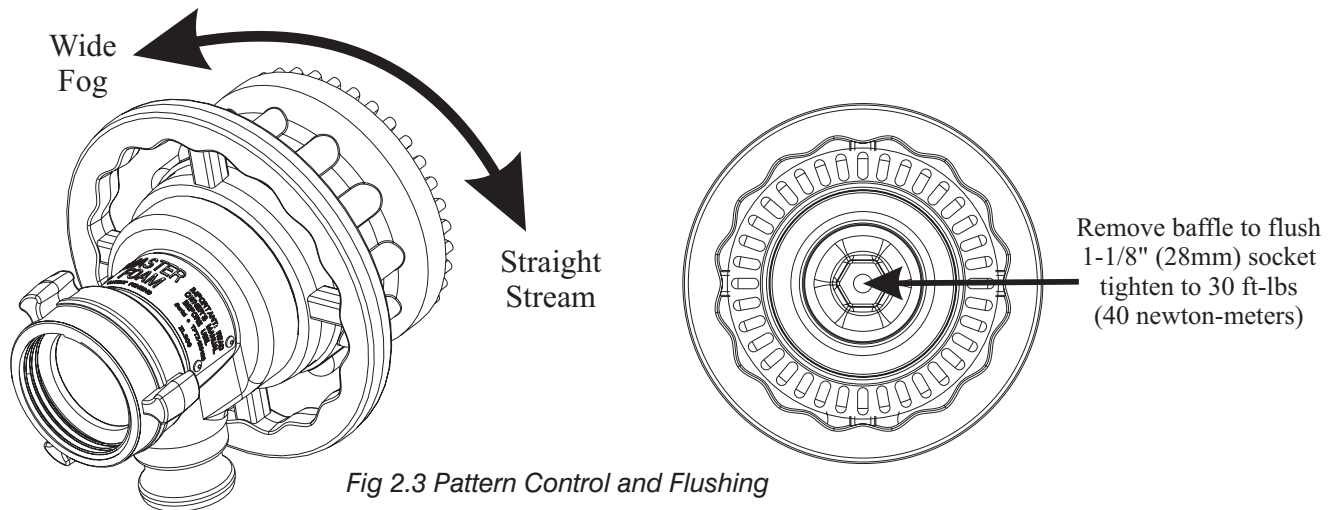

Fig 2.3 Pattern Control and Flushing

2.4 FLUSHING DEBRIS

Small debris in the water may get caught inside the nozzle. This trapped material will cause poor stream quality, shortened reach and reduced flow. To remove debris trapped in the nozzle:

- Shut off flow to the nozzle.
- Unscrew baffle (see figure 2.3) using 1-1/8 inch (28mm) socket.
- Remove debris. Flow water to flush if necessary.
- Reinstall baffle. Tighten to approximately 30 ft-lbs (40 Newton-Meters).

WARNING Large amounts of debris may be unflushable and can reduce the flow of the nozzle resulting in an ineffective flow. In the event of a blockage, it may be necessary to retreat to a safe area.

Larger debris can get caught in the nozzle ahead of the cast vane. If this occurs uncouple the nozzle to clear the blockage.

2.5 USE OF FOAM

Refer to fire service training for the proper use of foam.

⚠ WARNING For Class B fires, lack of foam or interruption in the foam stream can cause a break in the foam blanket and greatly increase the risk of injury or death. Make sure that:

- Application rate is sufficient (see NFPA 11 or foam manufacturer's recommendations).
- Enough concentrate is on hand to complete the task (see NFPA for minimum duration time requirements).
- Foam logistics have been carefully planned. Allow for such things as:
 - Storage of foam in a location not exposed to the hazard it protects.
 - Personnel, equipment and technique to deliver adequate foam.
 - Removal of empty foam containers.
 - Keeping clear path to deliver foam as hoses, other equipment and vehicles are deployed.

⚠ WARNING Improper use of foam can result in injury or damage to the environment. Follow foam manufacturer's instructions and fire service training to avoid:

- Using wrong type of foam on a fire, i.e. Class A foam on a Class B fire.
- Mishandling of concentrates, some of which are flammable.
- Plunging foam into pools of burning liquid fuels.
- Causing environmental damage.
- Directing stream at personnel.

⚠ WARNING There are a wide variety of foam concentrates. Each user is responsible for verifying that any foam concentrate chosen is suitable for the purpose intended.

2.5.1 FOAM SELECTION

See figure 2.5.1 for a summary of typical uses for various foam types.

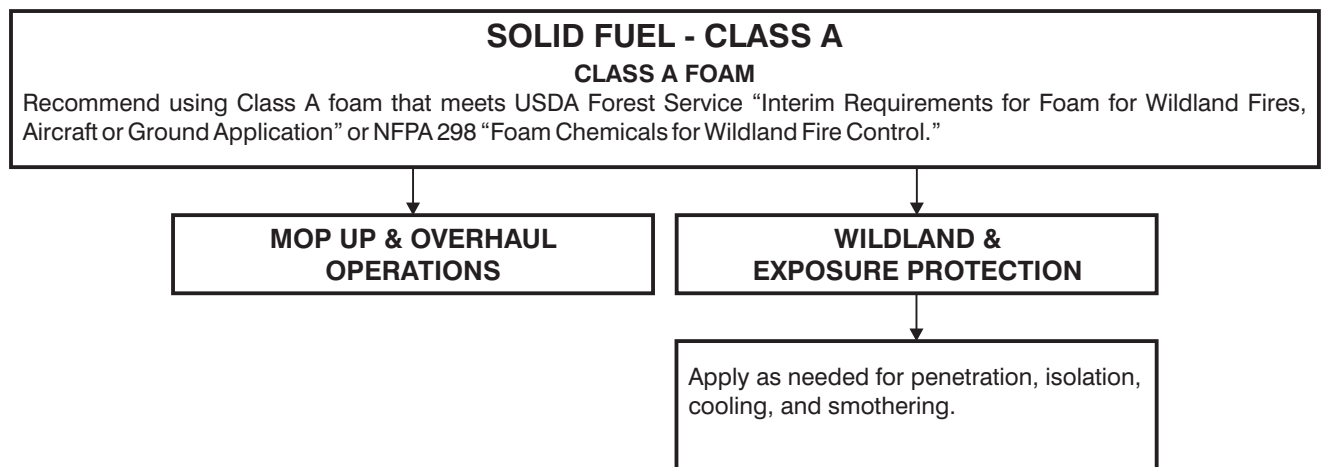

Fig 2.5.1a Basic Guide to Foam Selection and Use

2.5.1 FOAM SELECTION

See figure 2.5.1 for a summary of typical uses for various foam types.

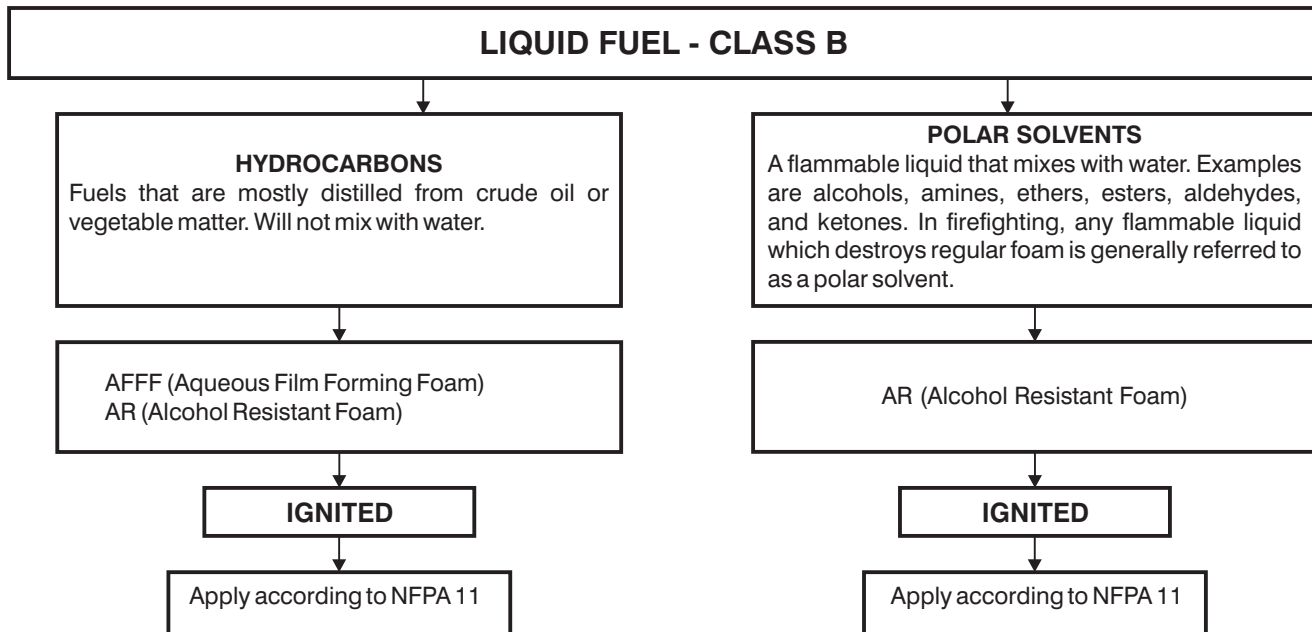

Fig 2.5.1b Basic Guide to Foam Selection and Use

2.5.2 SETTING FOAM PERCENTAGE

The foam percentage is controlled by an orifice plate that is installed in the nozzle at the mouth of the concentrate inlet (see figure 2.5.3). The MASTER FOAM comes with orifice plates for 0.5%, 1%, 3% and 6%. Each orifice plate is marked with the percentage and nozzle flow rate. The flow rate on the orifice plate must match the flow rate marked on the nozzle's baffle. The chart in fig 2.5.2a gives the nominal rates of foam usage. Accuracy of proportioning is fairly insensitive to nozzle inlet pressure. The graph in figure 2.5.2b gives expected percentages for various inlet pressures.

To install the orifice plate in the nozzle simply push it into the bore at the concentrate inlet on the nozzle. The orifice plate has an O-ring to hold it in place.

To remove the orifice plate, hook a small object (such as a screwdriver or Allen wrench) into the hole in the orifice plate and pull it out. Take care not to damage the orifice. Note: The hole in the 6% orifice plate is big enough that your finger can be used to pull it out instead of a tool.

CONCENTRATE FLOW RATE IN GPM

WATER FLOW (GPM)	FOAM PERCENTAGE			
	0.5%	1%	3%	6%
350	1.8	3.5	10.8	22.3
500	2.5	5.1	15.5	31.9
750	3.8	7.6	23.2	47.9

EXAMPLE: 500 GPM OF WATER AT 3% USES 15.5 GPM OF CONCENTRATE

NOTE: FLOWS SHOWN ARE NOMINAL. ACTUAL RESULTS MAY VARY BASED ON BRAND AND CONDITION OF FOAM

Fig 2.5.2a Concentrate Usage Chart

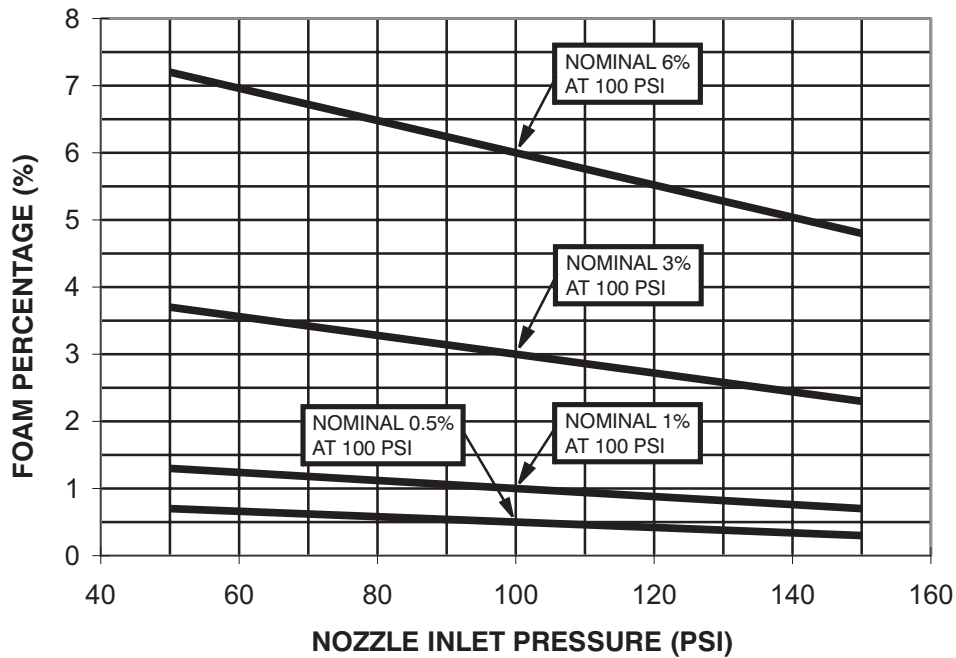

Fig 2.5.2b Proportioning Accuracy With Pressure Variation

Note: In any eductor type system the accuracy of proportioning depends on the viscosity of the foam concentrate. The orifice plates for the MASTER FOAM nozzle have been calibrated at 70 degrees F as follows:

PERCENT	FOAM USED FOR CALIBRATION
0.5% and 1%	Class A foam of 20 centipoise viscosity
3%	3M ATC 3 AR-AFFF product code ATC-603
6%	3M ATC-AFFF product code FC-600F

2.5.3 CONCENTRATE HOSE CONNECTION

The concentrate hose is attached to the MASTER FOAM nozzle by a 1.5 inch cam lock fitting (Military Standard: MS 27019). Orient levers to avoid interference with the stream shaper and push the fitting onto the concentrate inlet on the nozzle. Fold both levers until they touch the hose to lock. The other end of the hose is fed into a foam container. An optional hose is available with female camlock fittings on each end. Hose connection and typical set ups are shown in figure 2.5.3a and 2.5.3b.

2.5.4 USE OF FOAMJET LX

To increase the expansion ratio, Task Force Tips' "Foamjet LX" (model FJ-LX-M) may be used. This low expansion foam tube attaches and removes quickly from the nozzle. Note: As expansion ratio is increased the reach of the nozzle will be decreased due to the greater amount of bubbles in the stream and their inability to penetrate the air. Figure 2.5.4 gives approximate stream trajectory information with and without Foamjet LX. Actual results will vary based on brand of foam, hardness of water, temperature, etc.

2.5.5 CLEANING AFTER USE

After educting foam it is recommended that water be educted in through the concentrate hose and inlet. This will wash out foam concentrate residue in the hose, orifice plate, and nozzle passages. If not removed, any residue may dry and adversely affect the accuracy of proportioning.

2.5.6 USE WITH SALT WATER

Use with salt water is permissible provided nozzle is thoroughly cleaned with fresh water after each use. The service life of the nozzle may be shortened due to the effects of corrosion and is not covered under warranty.

For saltwater compatibility with foam, refer to supplier's technical data.

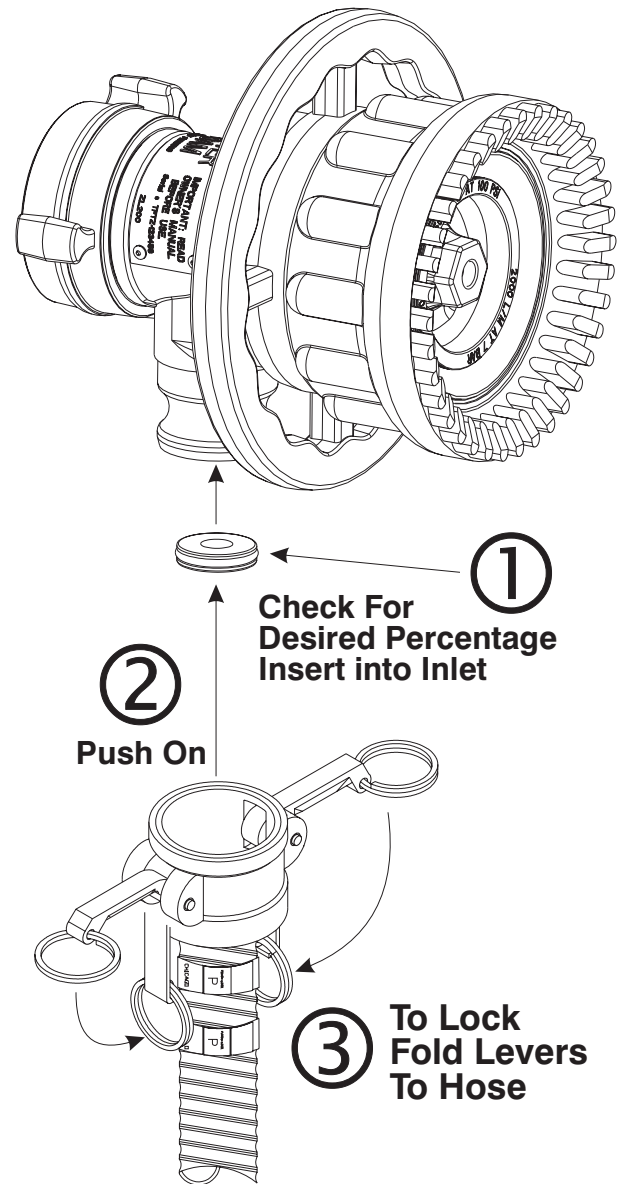

Fig 2.5.3a Orifice Plate and Concentrate Hose Connection

3.0 MAINTENANCE AND INSPECTION

The MASTER FOAM self-educting nozzle requires no routine maintenance. The shaper seal slides on a plastic surface and requires no grease. The nozzle should be inspected regularly to assure proper operation. In particular, check that:

- Coupling and gasket are tight and leak free.
- The desired orifice plate (flow and percentage) is installed.
- Concentrate inlet hose and gasket are damage and leak free.
- Flow passages are unobstructed.
- Baffle is in place and tightened securely.
- Shaper moves freely.

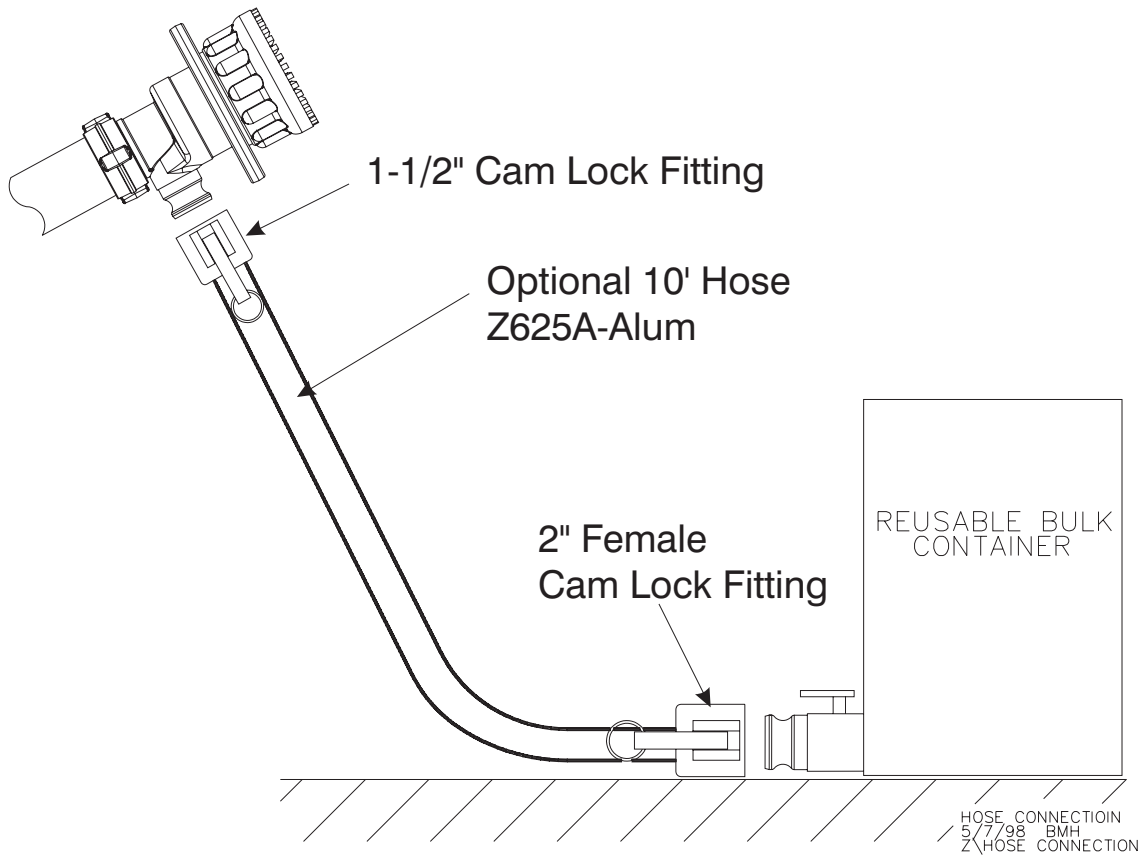
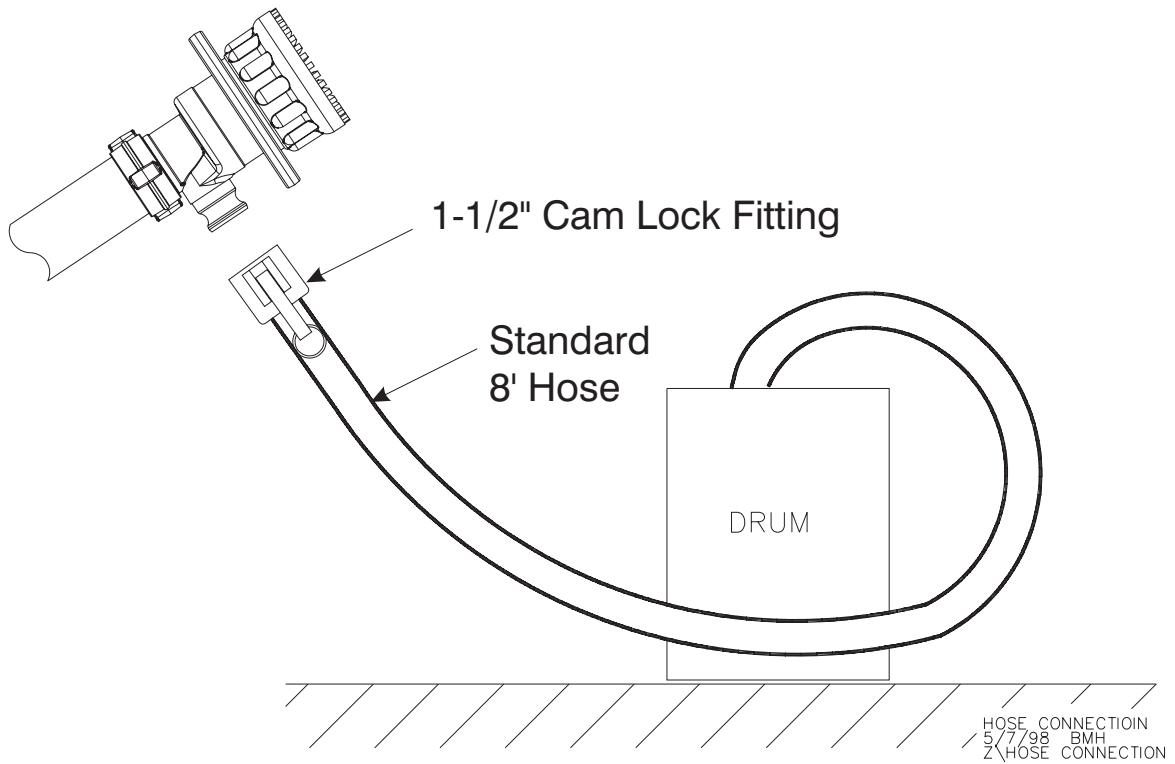
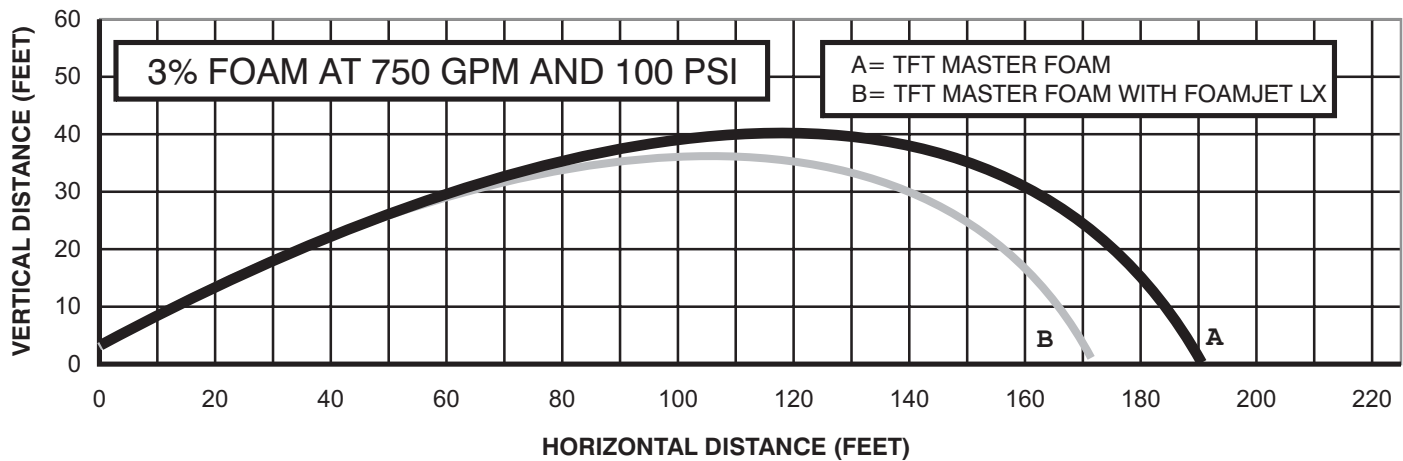
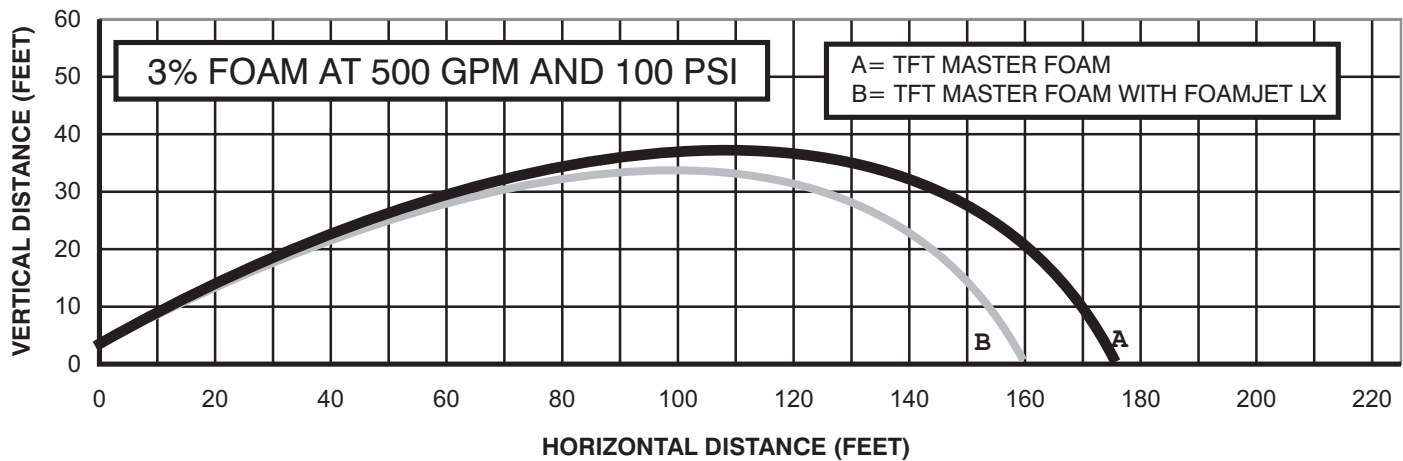
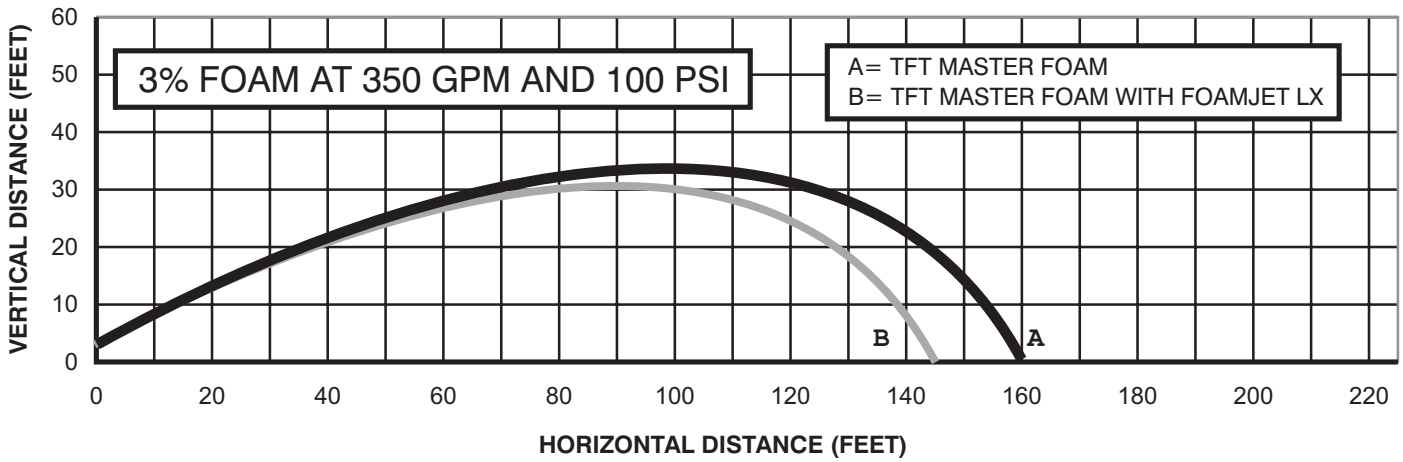

Fig 2.5.3b Typical Master Foam Set Ups



- APPROXIMATE EFFECTIVE STREAM TRAJECTORY AT 30 DEGREE ELEVATION IN NO WIND CONDITIONS. DISTANCE TO LAST FOAM DROP APPROXIMATELY 10% FARTHER.
- TRAJECTORIES SHOWN ARE FOR 3% FOAM. EFFECTIVE REACH WITH WATER IS APPROXIMATELY 10% FURTHER
- TAIL OR HEAD WINDS OF 20 MPH MAY INCREASE OR DECREASE THE RANGE APPROXIMATELY 30%.

Fig 2.5.4 Approximate Master Foam Stream Trajectory

4.0 EXPLODED VIEW AND PARTS LIST

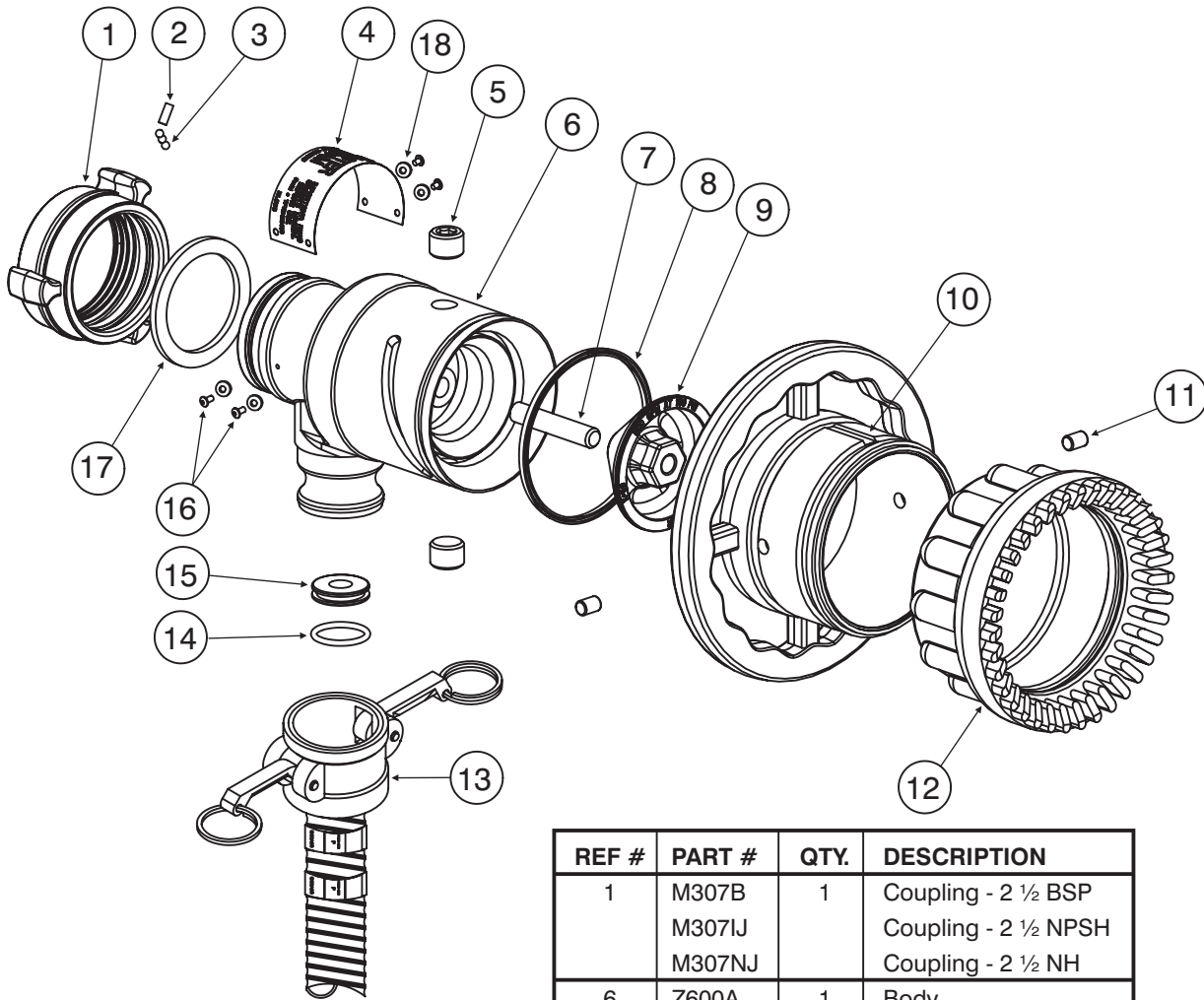

REF #	PART #	QTY.	DESCRIPTION
1	M307B M307IJ M307NJ	1	Coupling - 2 1/2 BSP Coupling - 2 1/2 NPSH Coupling - 2 1/2 NH
6	Z600A	1	Body
9	Z561A Z562A Z563A	1	Baffle 350 GPM Baffle 500 GPM Baffle 750 GPM
13	Z620A	1	8' Hose & Camlock

REF #	PART #	QTY.	DESCRIPTION
2	VT25-28SS500	1	1/4 - 28 x 1/2 Socket Set
3	V2120	48	3/16 SS Ball 302 SS
4	ZL200	1	MASTER FOAM Nozzle - Name Plate
5	VFSP4M	2	1/2 MNPT Hex Socket Plug
7	VT50-13SD2.7	1	1/2 - 13 x 2 3/4 Long Stud
8	Z630	1	Master Foam Shaper Seal
10	Z500	1	Shaper
11	Z660	2	Cam Pin
12	M700	1	Master Bumper
14	VO-217	1	O-Ring-217
15	Z610-*.*	1	Orifice Plate(Specify Flow and Percent)
16	VT06E32BH250	4	6-32 x 1/4 Button Head
17	V3185 V3190	1	2.5" BSP Coupling Gasket 2.5" Coupling Gasket (NH, NPSH)
18	VW375-156-30	4	Washer .375 OD x .156 ID x .030 Thick
-	Z621-R	1	Dust Cap (not pictured)

5.0 WARRANTY

Task Force Tips, Inc., Valparaiso, Indiana 46383 (“TFT”) warrants to the original purchaser of its MASTER FOAM Self-Educting Foam Nozzle (“equipment”), and to anyone to whom it is transferred, that the equipment shall be free from defects in material and workmanship during the five (5) year period from the date of purchase.

TFT’s obligation under this warranty is specifically limited to replacing or repairing the equipment (or its parts) which are shown by TFT’s examination to be in a defective condition attributable to TFT. To qualify for this limited warranty, the claimant must return the equipment to TFT, at 2800 East Evans Avenue, Valparaiso, Indiana 46383-6940, within a reasonable time after discovery of the defect. TFT will examine the equipment. If TFT determines that there is a defect attributable to it, it will correct the problem within a reasonable time. If the equipment is covered by this limited warranty, TFT will assume the expenses of repair.

If any defect attributable to TFT under this limited warranty cannot be reasonably cured by repair or replacement, TFT may elect to refund the purchase price of the equipment, less reasonable depreciation, in complete discharge of its obligations under this limited warranty. If TFT makes this election, claimant shall return the equipment to TFT free and clear of any liens and encumbrances.

This is a limited warranty. The original purchaser of the equipment, any person to whom it is transferred, and any person who is an intended or unintended beneficiary of the equipment, shall not be entitled to recover from TFT any consequential or incidental damages for injury to person and/or property resulting from any defective equipment manufactured or assembled by TFT. It is agreed and understood that the price stated for the equipment is in part consideration for limiting TFT’s liability. Some states do not allow the exclusion or limitation of incidental or consequential damages, so the above may not apply to you.

TFT shall have no obligation under this limited warranty if the equipment is, or has been, misused or neglected (including failure to provide reasonable maintenance) or if there have been accidents to the equipment or if it has been repaired or altered by someone else.

THIS IS A LIMITED EXPRESS WARRANTY ONLY. TFT EXPRESSLY DISCLAIMS WITH RESPECT TO THE EQUIPMENT ALL IMPLIED WARRANTIES OF MERCHANTABILITY AND ALL IMPLIED WARRANTIES OF FITNESS FOR A PARTICULAR PURPOSE. THERE IS NO WARRANTY OF ANY NATURE MADE BY TFT BEYOND THAT STATED IN THE DOCUMENT.

This limited warranty gives you specific legal rights, and you may also have other rights which vary from state to state.

TASK FORCE TIPS, INC.
Made in U.S.A. • www.tft.com

2800 E Evans Ave, Valparaiso, IN 46383-6940 USA
800-348-2686 • 219-462-6161 • Fax 219-464-7155