



# MANUAL: Remote Control (RC) Monitor Electrical Controls

Supplemental Instructions for use with RC Monitor Manual

## INSTRUCTIONS FOR INSTALLATION, SAFE OPERATION AND MAINTENANCE

**⚠ DANGER**

Understand manual before use. Operation of this device without understanding the manual and receiving proper training is a misuse of this equipment. Obtain safety information at [www.tft.com/serial-number](http://www.tft.com/serial-number)

### SECTION 3.0

General Information and Specifications

### SECTION 4.0

Electrical Controls Installation and Operation

### SECTION 4.1

Monitor Mounted Operator Station



### SECTION 4.2

Panel Mount Operator Station (Y4E-RP)



### SECTION 4.3

Panel Mount With Display Operator Station (Y4E-RP-D)



### SECTION 4.4

Tethered Operator Station (Y4E-CT-##)

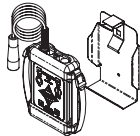

### SECTION 4.5

Tethered Operator Station With Display (Y4E-CT-##-D)

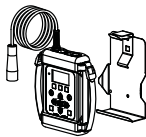

### SECTION 4.6

Wireless Operator Station (YE-RF-##)



### SECTION 4.7

Wireless Operator Station With Display (YE-RF-##-D)

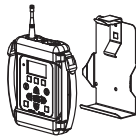

### SECTION 4.8

Joystick Operator Station (Y4E-JS)

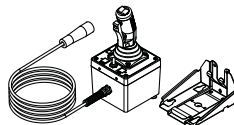

### SECTION 4.9

Toggle Switch Monitor Operator Station (Y4E-TS)

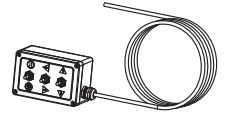

### SECTION 4.10

Monitor Communication Interface Control (Y4E-COMM)

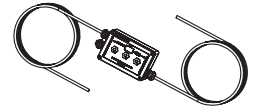

### SECTION 4.11

Monitor Position Display (Y4E-DISP)

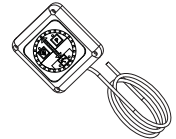

### SECTION 4.12

Remote Auxiliary Function Interface Control (YE-REMAUX)

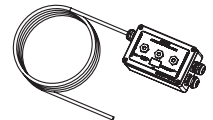

### SECTION 4.13

Electric RC Monitor Aerial Truck Installation

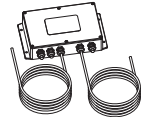

### SECTION 4.14

Multiplex Interface Control (YE-CAN#)

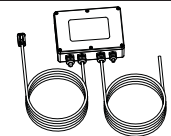

### SECTION 4.15

Ethernet Interface Control

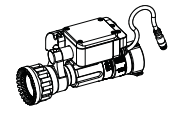

### SECTION 4.16

Electric Nozzle Actuator

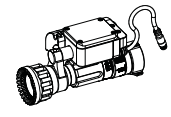

### SECTION 4.17

Valve Kits (YE-VK-PH)

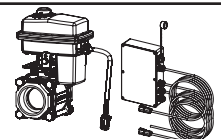

### SECTION 5.0

Troubleshooting

**TASK FORCE TIPS LLC**

MADE IN USA • [tft.com](http://tft.com)

3701 Innovation Way, IN 46383-9327 USA  
800-348-2686 • 219-462-6161 • Fax 219-464-7155

## DANGER

### PERSONAL RESPONSIBILITY CODE

The member companies of FEMSA that provide emergency response equipment and services want responders to know and understand the following:

1. Firefighting and Emergency Response are inherently dangerous activities requiring proper training in their hazards and the use of extreme caution at all times.
2. It is your responsibility to read and understand any user's instructions, including purpose and limitations, provided with any piece of equipment you may be called upon to use.
3. It is your responsibility to know that you have been properly trained in Firefighting and /or Emergency Response and in the use, precautions, and care of any equipment you may be called upon to use.
4. It is your responsibility to be in proper physical condition and to maintain the personal skill level required to operate any equipment you may be called upon to use.
5. It is your responsibility to know that your equipment is in operable condition and has been maintained in accordance with the manufacturer's instructions.
6. Failure to follow these guidelines may result in death, burns or other severe injury.



Fire and Emergency Manufacturers and Service Association  
P.O. Box 147, Lynnfield, MA 01940 • [www.femsa.org/prc.cfm](http://www.femsa.org/prc.cfm)





©2009 FEMSA, All Rights Reserved

# Table Of Contents





1.0	Meaning of Safety Signal Words.....	4	4.6.3	Teaching ID Code	
2.0	Safety .....	4	4.6.4	Changing Batteries	
3.0	General Information and Specifications .....	4	4.6.5	Operation	
3.1	Electrical Specifications		4.7	Wireless Operator Station With Display .....	21
3.2	Electrical Controls		4.7.1	Mounting Storage Bracket	
3.2.1	Motor Control Board (MCB) Auto Configure		4.7.2	Installing Radio/Antenna	
3.2.2	Motor Current Limiting		4.7.3	Basic Operation	
3.2.3	Motor Soft Stops		4.7.4	Display Controlled Operation	
3.2.4	Motor Slow/Fast Speed		4.7.5	Teaching ID Code	
3.2.5	Communication Protocol		4.7.6	Configuration of Multiple Monitor Control	
3.2.6	Oscillate and Park Features		4.7.6.1	Teaching ID Code To Multiple Monitors and Wireless Unit	
3.2.7	Smart Stream Technology		4.7.6.2	Monitor Group Configuration	
3.2.8	Monitor Disable Interlock		4.7.7	Changing Batteries	
3.2.9	Monitor Sit-N-Stay Feature		4.8	Joystick Operator Station .....	25
3.2.10	Monitor Deploy Feature		4.8.1	Mounting Storage Bracket	
4.0	Electrical Controls Installation and Operation .....	6	4.8.2	Operation	
4.0.1	Operator Stations		4.8.2.1	Proportional Speed Control	
4.0.2	Button Overlay		4.8.2.2	Monitor Deploy Feature	
4.0.3	Setting up a Mastering Operating Station		4.8.2.3	RC Extend-a-gun Control	
4.0.4	Park Feature		4.8.3	Joystick Board Configuration	
4.0.4.1	Programming		4.8.4	Gateable Valve Control	
4.0.4.2	Park Programming Example		4.9	Toggle Switch Monitor Operator Station .....	28
4.0.4.3	Selecting Nozzle Direction During Park		4.9.1	Enclosure Mounting	
4.0.5	Oscillate Feature		4.9.2	Electrical Wiring	
4.0.5.1	Programming		4.9.3	Operation	
4.0.5.2	Oscillate Pattern Retain Feature (DIP #4)		4.10	Monitor Communication Interface Control .....	29
4.0.6	Override Knobs		4.10.1	Enclosure Mounting	
4.1	Monitor Mounted Operator Station .....	11	4.10.2	Electrical Wiring	
4.1.1	Mounting		4.10.3	Inputs Signal Configuration	
4.1.2	Electrical Wiring		4.10.4	Communication Interface Box With AT PARK Relay	
4.1.3	Connecting Directly to Protected Power Supply		4.11	Monitor Position Display .....	30
4.1.4	Operation		4.11.1	Enclosure Mounting	
4.1.5	Button Overlay		4.11.2	Electrical Wiring	
4.2	Panel Mount Operator Station .....	12	4.11.3	Programming Display	
4.2.1	Mounting		4.12	Remote AUXiliary Function Interface Control .....	32
4.2.2	Electrical Wiring		4.12.1	Enclosure Mounting	
4.2.3	Inputs Signal Configuration		4.12.2	Electrical Wiring	
4.2.4	Panel Mount Operator Station With AT PARK Relay		4.12.3	Configuration	
4.2.5	Operation		4.13	Electric RC Monitor Aerial Truck Installation .....	33
4.3	Panel Mount Operator Station With Display .....	14	4.13.1	Electronics Enclosure Mounting	
4.3.1	Mounting		4.13.2	Electrical Wiring	
4.3.2	Electrical Wiring		4.13.2.1	Ladder Installation Electrical Wiring	
4.3.3	Panel Mount Operator Station With Display At Park Relay		4.13.2.2	Platform Installation Electrical Wiring	
4.3.4	Controller Area Network (CAN) Communication Bus		4.13.3	Recommended Ladder Installation Configuration	
2.3.4.1	CAN Wiring Configuration		4.13.4	Electrical Enclosure With AT PARK Relay	
2.3.4.2	CAN Bus Termination		4.13.5	Electrical Enclosure With Inhibit Input	
4.3.5	Basic Operation		4.14	Multiplex Interface Control (YE-CAN#).....	37
4.3.6	Display Controlled Operation		4.15	Ethernet Interface Control .....	38
4.4	Tethered Operator Station .....	16	4.15.1	Interface Enclosure Mounting	
4.4.1	Mounting Storage Bracket		4.15.2	Electrical Wiring	
4.4.2	Receptacle Mounting		4.15.3	Default Network Settings	
4.4.3	Electrical Wiring		4.16	Electric Nozzle Actuator .....	39
4.4.4	Operation		4.16.1	Wiring	
4.5	Tethered Operator Station With Display .....	18	4.16.2	Operation of Flush, Fog, Stream	
4.5.1	Mounting Storage Bracket		4.17	Valve Kits .....	40
4.5.2	Receptacle Mounting		4.17.1	Valve Mounting	
4.5.3	Electrical Wiring		4.17.2	Interface Enclosure Mounting	
4.5.4	Controller Area Network (CAN) Communication Bus		4.17.3	Electrical Wiring	
2.5.4.1	CAN Wiring Configuration		4.17.4	Configuration	
2.5.4.2	CAN Bus Termination		5.0	Troubleshooting .....	42
4.5.5	Basic Operation		6.0	Warranty .....	43
4.5.6	Display Controlled Operation				
4.6	Wireless Operator Station .....	19			
4.6.1	Mounting Storage Bracket				
4.6.2	Installing Radio/Antenna				

## 1.0 MEANING OF SAFETY SIGNAL WORDS

A safety related message is identified by a safety alert symbol and a signal word to indicate the level of risk involved with a particular hazard. Per ANSI standard Z535.6-2011, the definitions of the four signal words are as follows:

	<b>DANGER</b> indicates a hazardous situation which, if not avoided, will result in death or serious injury.
	<b>WARNING</b> indicates a hazardous situation which, if not avoided, could result in death or serious injury.
	<b>CAUTION</b> indicates a potentially hazardous situation which, if not avoided, could result in minor or moderate injury.
	<b>NOTICE</b> is used to address practices not related to physical injury.

## 2.0 SAFETY

	The RC monitor control boxes and motors are not rated as ignition proof, explosion proof, or intrinsically safe. Install in locations with adequate ventilation and no hazard of flammable vapor buildup.
	Disconnect power before installing or servicing the monitor to avoid electrical shock or injury from moving parts.
	Remote controlled equipment moves without warning placing nearby persons at risk of pinch points, loss of footing, or stream impact. Assume command of remote operation only after safe zones are established. Keep clear of powered equipment when the controls are energized.
	Do not use AC voltage to operate the RC product. The RC product is a 12 or 24VDC system ONLY! Using the wrong power source could cause electrocution, resulting in death or serious injury.

## 3.0 GENERAL INFORMATION AND SPECIFICATIONS

### 3.1 ELECTRICAL SPECIFICATIONS

Nominal operating voltage:	12 or 24 VDC (auto sense)			
Motor current:	Nominal*		Limit	
	@ 12 VDC	@24 VDC	@ 12 VDC	@24 VDC
Elevation motor:	6 amps	3 amps	15 amps	7.5 amps
Horizontal rotation motor:	6 amps	3 amps	10 amps	5 amps
Nozzle motor:	1 amp	0.5 amps	5 amps	2.5 amps
	*with rated water pressure applied			
At rest current:	.25 amps @ 12 VDC			
Recommended fuse size:	15 amps @ 12 volts, 7.5 amps @ 24 volts			
Operating temperature range:	-30F to +120F (-34C to +49C)			
Environmental Rating:	All components designed to meet minimum rating of NEMA 4 (IP65) except the Joystick which is intended for dry service within the interior of a cab.			

### WIRELESS OPERATOR STATION (YE-RF-##)

	YE-RF-900 & YE-RF-900-D, 900 MHz	YE-RF-2400, 2.4 GHz
Handheld Unit Batteries	Four (AA) Batteries, Lithium Recommended	
Transmitting Power	100mW	50mW
Operating Range	500 ft (152m)	
Operating Frequency	900 MHz (902-928 MHz)	2.4GHz (2.4000-2.4835 GHz)
Agency Approvals		
FCC	MCQ-XBPS3B	OUR24XSTREAM
Industry Canada (IC)	1846A-XBPS3B	4214A-12.008
Europe	N/A	ETSI

**YE-RF-900 & YE-RF-900-D** CONTAINS FCC ID: MCQ-XBPS3B THE ENCLOSED DEVICE COMPLIES WITH PART 15 OF THE FCC RULES. OPERATION IS SUBJECT TO THE FOLLOWING TWO CONDITIONS: (1) THIS DEVICE MAY NOT CAUSE HARMFUL INTERFERENCE AND (2) THIS DEVICE MUST ACCEPT ANY INTERFERENCE RECEIVED, INCLUDING INTERFERENCE THAT MAY CAUSE UNDESIRE OPERATION.

**YE-RF-2400** CONTAINS FCC ID: OUR-24XSTREAM THE ENCLOSED DEVICE COMPLIES WITH PART 15 OF THE FCC RULES. OPERATION IS SUBJECT TO THE FOLLOWING TWO CONDITIONS: (1) THIS DEVICE MAY NOT CAUSE HARMFUL INTERFERENCE AND (2) THIS DEVICE MUST ACCEPT ANY INTERFERENCE RECEIVED, INCLUDING INTERFERENCE THAT MAY CAUSE UNDESIRE OPERATION.

## **3.2 ELECTRICAL CONTROLS**

The electric TFT RC monitor is controlled by a very powerful, state-of-the-art electronics system. The key components of the system are the motor control boards and a communication board. Each motor control board has its own microprocessor and a sophisticated motor control chip. The communication board also has a microprocessor, which handles the interface to the operator stations. All the components on these boards are solid state; there are no relays or electromechanical devices to wear out over time. The hardware and software have been designed with several key features:

### **3.2.1 MOTOR CONTROL BOARD (MCB) AUTO CONFIGURE**

Each monitor has three MCBs, one for each motor. The MCB controls motor movement and direction for horizontal rotation, elevation, and nozzle pattern. In the unlikely event of a MCB failure, the failed board can be removed and one of the other two remaining MCBs can be moved into that position. This MCB will then auto configure itself to take over the control of that axis, so that the monitor can continue to be used, with two of the three motors. This is also a helpful benefit when troubleshooting and requires fewer spare parts to be stocked.

### **3.2.2 MOTOR CURRENT LIMITING**

The microprocessor on the MCB continuously monitors the motor current. As the motor reaches an end stop or if there is an obstruction, the motor current rises very quickly and the motor control chip automatically shuts down the motor in a few milliseconds. This eliminates the need for any type of external limit switches and the associated wiring. The microprocessor also locks the operator from moving in the stopped direction again, until the operator first moves in the opposite direction.

### **3.2.3 MOTOR SOFT STOPS**

The horizontal and vertical motors are equipped with feedback encoders which allow the microprocessor to know the motor position at all times. The first time a motor reaches an end stop or strikes an obstruction, the microprocessor sets a new soft stop position just before the end stop. From that point on, when the axis approaches the stop, the MCB automatically slows down the motor until the end stop is reached. This significantly reduces the wear on the motor, gearbox, and gear drives.

### **3.2.4 MOTOR SLOW/FAST SPEED**

When an operator presses one of the buttons, the associated motor starts in low speed mode for accurate control of the water stream. For Tornado Monitors, after approximately ½ second the motor automatically ramps up to high speed, for quickly moving into position. For all other monitors, the speed ramps up after 2 seconds. When quickly changing directions, monitor remains at speed of prior move. If low speed is selected, monitor does not ramp to high speed but remains in low speed.

### **3.2.5 COMMUNICATION PROTOCOL**

The communication from the monitor to the operator stations is performed over two wires using RS-485 serial protocol. Multiple operator stations can be added with only two wires for power and two wires for the RS-485 protocol between each station.

### **3.2.6 OSCILLATE AND PARK FEATURES**

The OSCILLATE feature allows the user to program up to 65 points of continuous movement of the horizontal and vertical axes. The OSCILLATE pattern can be programmed from any operator station that has the OSC button.

The PARK feature allows the user to move the monitor, with one touch of a button, to a safe position before moving the fire truck. The monitor will always move to two end stops to verify the correct position. During the programming procedure, the user has the ability to select which axis moves first. This is helpful to avoid lights, hoses, obstructions, etc. The user can program up to 10 points of movement to reach the final park position. The PARK pattern can be programmed from any operator station that has low profile keypad buttons. A relay contact is available for connection to the truck alarm

### **3.2.7 SMART STREAM TECHNOLOGY**

This technology, only available with TFT RC nozzles, utilizes a position encoder in the nozzle actuator to give the user greater control on the stream pattern, especially at FOG position. Nozzles equipped with a FLUSH position are programmed to stop and pause at full FOG position when moving towards the FLUSH position, preventing unwanted water flow. A second press on the button will cause the nozzle shaper to continue to move to FLUSH position for removing debris from the nozzle.

### **3.2.8 MONITOR DISABLE INTERLOCK**

This feature, only available with TFT RC Extend-A-Guns and Ladder/Platform versions of monitors, provides an interlock for RC monitors that are installed on trucks in extremely confined spaces. This interlock can also be used to prevent a RC monitor from moving and potentially damaging surrounding equipment. TFT RC Extend-A-Guns are shipped with the Monitor Disable Interlock feature enabled. This feature prevents the monitor from moving when the RC Extend-A-Gun is in the retracted position. Ladder/Platform versions of monitors require a signal wired to an inhibit input in the aerial electronics interface box. Once active this interlock will prevent the monitor from damaging the apparatus that the monitor is installed on and prevent operator error from causing costly damage.

### **3.2.9 MONITOR SIT-AND-STAY FEATURE**

Once the PARK pattern has been performed, the monitor will enter an active state of checking axis positions. If road vibration causes the axes to move or an operator tries to move the manual override knob, the motor control boards will command the motors back to the PARK axis position. This feature can be cancelled by hitting any of the movement buttons on the membrane switch. This feature is not disabled by the INHIBIT interlock feature. Power must be applied to the RC monitor for this feature to remain active.

### 3.2.10 MONITOR DEPLOY FEATURE

This feature available through YE-CAN1 Multiplex Interface Control, Y4E-JS Joystick Operator Station, Y4E-RP-D Panel Mount Operator Station with Display, Y4E-CT-##-D Tether Operator Station with Display, and YE-RF-##-D Wireless Operator Station with Display, will move the RC monitor horizontal & vertical axes to a predetermined position. This feature is useful to quickly move the monitor from a PARK position into an attack position, ready for water flow. Initiating a DEPLOY movement will command each axis to 50% of their overall travel limits.

<b>IMPORTANT</b> Review these sections and decide on locations before starting installation process.	
<b>4.0 Electrical Controls Installation</b> <b>4.1 Monitor Mounted Operator Station</b> <b>4.2 Panel Mount Operator Station (Y4E-RP)</b> <b>4.3 Panel Mount Operator Station with Display (Y4E-RP-D)</b> <b>4.4 Tether Operator Station (Y4E-CT-##)</b> <b>4.5 Tether Operator Station with Display(Y4E-CT-##-D)</b> <b>4.6 Wireless Operator Station (YE-RF-##)</b> <b>4.7 Wireless Operator Station with Display (YE-RF-##-D)</b> <b>4.8 Joystick Operator Station (Y4E-JS)</b>	<b>4.9 Toggle Switch Monitor Operator Station (Y4E-TS)</b> <b>4.10 Communication Interface Control (Y4E-COMM)</b> <b>4.11 Monitor Position Display (Y4E-DISP)</b> <b>4.12 Remote Auxiliary Function Interface Control (YE-REMAUX)</b> <b>4.13 Aerial (Ladder &amp; Platform) Controls</b> <b>4.14 Multiplex Interface Control (YE-CAN#)</b> <b>4.15 Ethernet Interface Control (YE-ETHER)</b> <b>4.16 Electric Nozzle Actuator</b> <b>4.17 Valve Kits (YE-VK*)</b>

### 4.0 ELECTRICAL CONTROLS INSTALLATION AND OPERATION

The electric RC monitor is supplied with a monitor mounted operator station. The wiring on the monitor and for this operator station is factory installed. The assembly is supplied with a cable for connection to the operator control stations as shown in Figure 4.0 or directly to a protected voltage supply. This cable has 4-conductors which supply power and the communications from the operator stations to the monitor. To complete the installation, the installer will need to mount and wire the selected operator stations. The power supply for the monitor will need to be connected to a protected (fused) circuit from the truck's power distribution center. Refer to the specifications section 3.1 for nominal current draw.

For installations where the customer would like to turn off the voltage to the monitor independent of the truck master switch, the installer needs to install a user supplied SPST (single-pole single-throw) toggle switch. Install this toggle switch in a location that can quickly be accessed before using the RC monitor. The toggle switch needs to be wired between the protected voltage supply and the red wire feeding the RC monitor.

### **NOTICE** INSTALLATION AND SERVICE PRACTICES

- Disconnect power before installing or servicing the electrical components to avoid electrical shock hazard or injury due to moving parts.
- Provide adequate power for all electrical controls and motors taking into account voltage drops on wiring. See section 3.1 for electrical specifications.
- Careful selection of wiring is critical to avoid excessive voltage drop.
- Good mechanical connections on the wires are absolutely necessary and should be checked periodically. Poor electrical connections can cause power loss to the electric RC monitor and be a fire hazard.
- Be careful to route cables and controls in protected areas away from high heat sources.
- Use grommets whenever wires pass through holes to prevent damage due to snags, abrasions, etc.
- Secure cables close to control box with plastic wire ties or cable clamps to relieve stress on the cables.
- Observe precautions for electrostatic sensitive devices when installing or servicing controls. Touch fingers to bare metal surface before handling control boards to dissipate static electricity.
- Make sure that all control covers and gaskets are restored to their original condition after installation or servicing to maintain weather tight seal.
- Ensure ground wires are connected to a proper grounding connection or ground stud capable of handling required current. Do not rely on chassis or frame ground as these connection can deteriorate over time. Run ground wire directly to battery terminal if necessary.

**Recommended Tool List** - 11/32" nut driver - Wire cutter/stripper - Terminal crimping tool - Utility knife - 20mm open-end box wrench - 17mm open-end box wrench - 3mm hex wrench - 5/32" drill bit - 25/32" drill bit - #2 Phillips screwdriver - Small flat blade screwdriver

<b>IMPORTANT</b> - When mechanical installation and electrical connections are complete, perform the following test to verify voltage supply is adequate and the current limiting feature is functioning.  1) Apply power to monitor control box. 2) Press LEFT or RIGHT button and hold until monitor reaches its stop position. Continue to hold button down. 3) Once movement is stopped, manually turn override knob in opposite direction while continuing to hold button down. If knob can be turned, then voltage supply is adequate. If knob cannot be turned and motor continues to operate, then the voltage supply or wiring is not adequate. Check connections and voltage connection point, rewire if necessary. <b>NOTE: Override knob will only turn in one direction.</b>
---

**NOTICE**

To avoid excessive voltage drop at monitor operator station, do not lengthen factory supplied monitor cable. Power cable selection is critical. Voltage supplied to MONITOR should not fall below value listed in table when monitor is in operation.

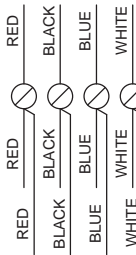

**TYPICAL TERMINAL BOX CONNECTIONS**

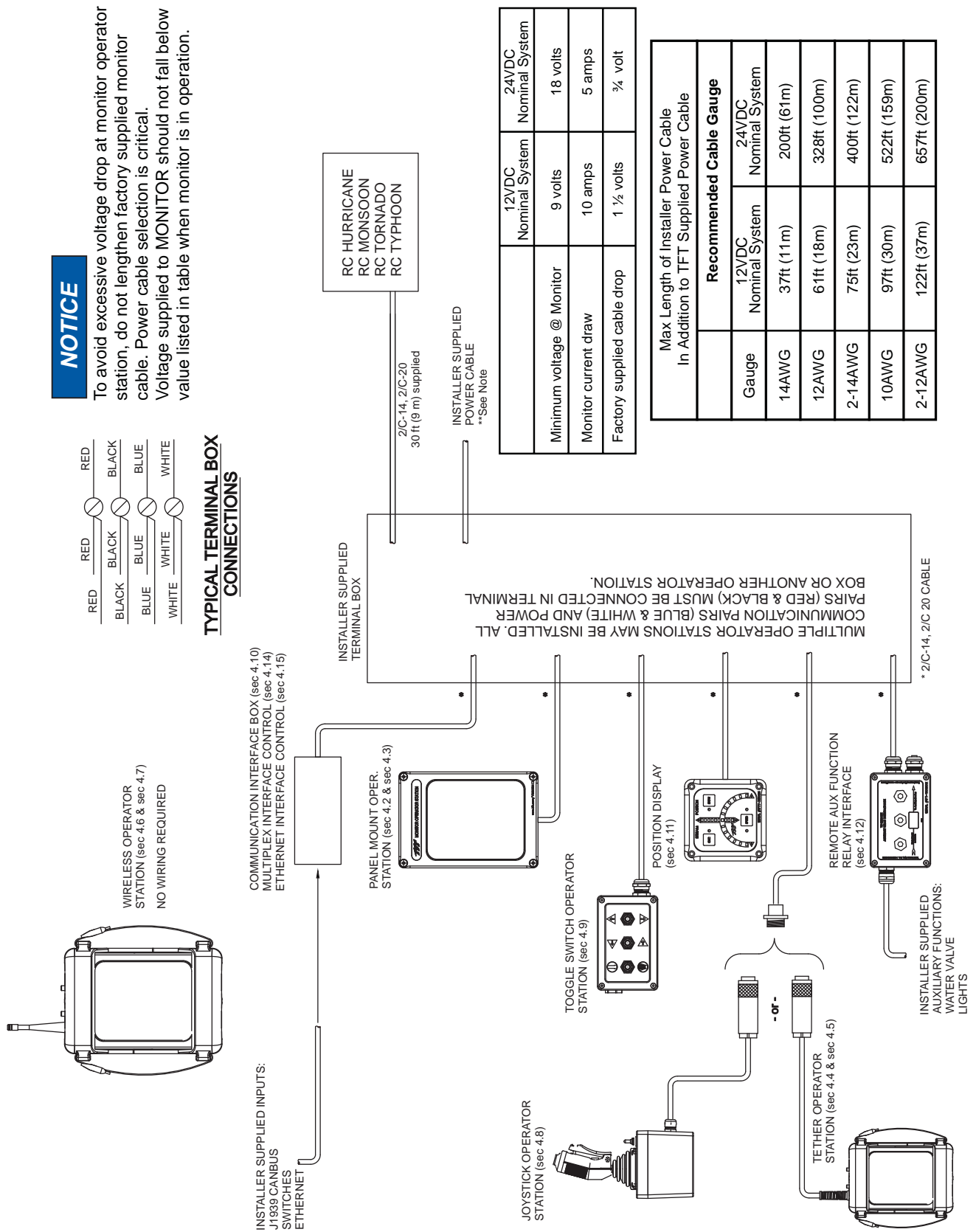

	12VDC Nominal System	24VDC Nominal System
Minimum voltage @ Monitor	9 volts	18 volts
Monitor current draw	10 amps	5 amps
Factory supplied cable drop	1 ½ volts	¾ volt

Max Length of Installer Power Cable In Addition to TFT Supplied Power Cable		
Gauge	12VDC Nominal System	24VDC Nominal System
14AWG	37ft (11m)	200ft (61m)
12AWG	61ft (18m)	328ft (100m)
2-14AWG	75ft (23m)	400ft (122m)
10AWG	97ft (30m)	522ft (159m)
2-12AWG	122ft (37m)	657ft (200m)

Fig. 4.0  
 ELECTRICAL COMPONENTS  
 (non-aerial installation)

## 4.0.1 OPERATOR STATIONS

The electric RC monitor has five different styles of operator stations for use in various locations on the fire truck or fire ground.

The design of the operator station communications allows users to override commands on other stations. The “last” button pressed has control. The overridden user can regain control by releasing his/her button and pressing again.

Platform and ladder electronics enclosures are pre-configured for one set of inputs to have a master override feature. The operator station connected to these inputs, typically at the base of the ladder, will override any other operator station.

Any operator station with a communication board or connected to a communication board can be field configured with the master override feature. This allows the user to setup an operator station on the fire truck or fire ground as the master override station.

This operator station is factory installed on the monitor and is used by personnel at the monitor.

OSCILLATE button used to initiate monitor movement through stored sequence (pattern) or to program a sequence (pattern).

FOG button used to move nozzle pattern to wide and short reach.

LEFT button used to rotate (sweep) water stream from right to left from starting point.

DOWN button used to move water stream vertically down from starting point.

MONITOR UP/DOWN button typically used to control RC Extend-A-Gun. Also known as the AUX1 button. Could also be used with YE-REMAUX relay interface box to control other devices.

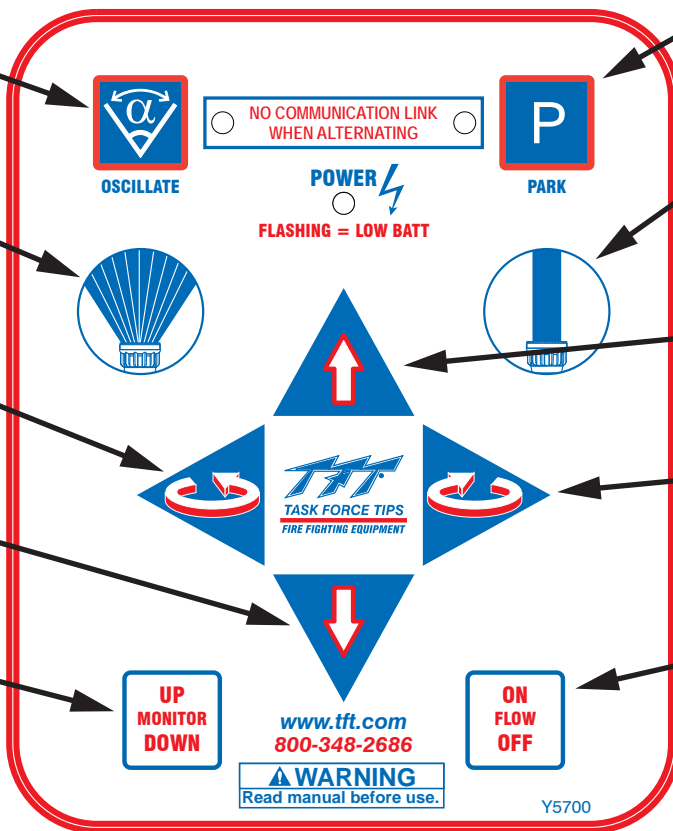

PARK button used to initiate monitor storage sequence or to program storage movements.

STRAIGHT STREAM button used to move nozzle pattern to narrow and long reach.

UP button used to move water stream vertically up from starting point.

RIGHT button used to rotate (sweep) water stream from left to right from starting position.

FLOW ON/OFF button typically used to control RC Valve Kit or VUM. Also known as the AUX2 button. Could also be used with YE-REMAUX relay interface box to control other devices.

Fig. 4.0.1 Operator Station Control Pad

## 4.0.2 BUTTON OVERLAY

Each monitor and operator station is shipped with several button overlays with adhesive that can be used to cover the button text on the lower two buttons. This can be done in applications that do not have either an RC Extend-A-Gun or RC valve kit. If additional overlays are needed, contact the factory.

Clean operator station surface to remove any oils or residues. Carefully peel off overlay and place on top of AUX button, just inside blue border of the button.

## 4.0.3 SETTING UP A MASTER OPERATING STATION

Any remote operator station or interface board can be re-configured to override all other operator stations. These stations include the Y4E-RP, Y4E-RP-D, Y4E-CT-##, Y4E-CT-##-D, Y4E-TS, Y4E-JS, YE-RF-##, YE-RF-##-D, or any inputs connected to an interface box such as Y4E-COMM or ladder/platform enclosures.

**Note: A master station will override another master station.**

To enable the master override feature, follow these steps:

1. Ensure power is OFF to the unit.
2. Remove lid from enclosure.
3. Locate configuration DIP switches on circuit board.
4. Slide DIP switch #1 to the ON position for a master station.
5. Replace lid. Verify rubber seal is clean and undamaged. Verify that no wires are caught between lid and box.

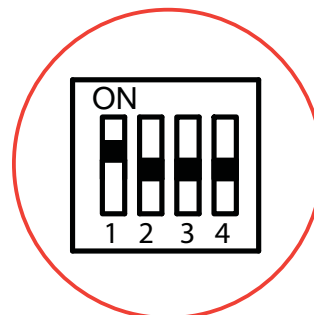

Figure 4.0.3 Master Override Setup



## 4.0.4 PARK FEATURE

The PARK position needs to be programmed during installation. The monitor needs to “find” two (2) hard stops, one for each axis, before the monitor can move to the PARK position. When programming, the first two commands teach the monitor where to find the hard stops. This guarantees that the position is accurate. From that point, the programmer can program the move to the final PARK position.

During normal operation, each time the PARK button is pressed, the monitor moves the nozzle to the full straight stream position, moves to each programmed hard stop, and then moves to the PARK position. While the monitor is performing the PARK feature, pressing any button will stop the monitor. If the installer prefers to have the nozzle move to the full fog position during the PARK pattern, see section 4.0.4.3.

**RECOMMENDED PARK POSITION:** For truck mounted applications, it is recommended that the monitor be parked in a position such that the monitor’s nozzle rests against a bracket or support surface. This will minimize bouncing of the nozzle when the apparatus is traveling. Always be sure the monitor is properly parked before moving the truck and know the overall height to avoid damage from overhead obstructions such as doors or bridges.

**NOTE:** Depending on the manufactured date, it may be necessary to deploy the Extend-A-Gun in order to enter PARK programming mode.

### 4.0.4.1 PROGRAMMING

#### **PARK PROGRAMMING MUST BE INITIATED WITHIN 1 MINUTE OF APPLYING POWER TO MONITOR.**

After 1 minute, programming access is blocked. Power must then be cycled to reset 1 minute timer.

Press and hold PARK button (~10 seconds) until light blinks. Release button. Light will continue to blink while in program mode.

#### **FIRST AXIS TO MOVE:**

Press and release LEFT/RIGHT or UP/DOWN button of axis that will move to first hard stop. Light will blink rapidly when hard stop is reached.

#### **SECOND AXIS TO MOVE:**

Press and release LEFT/RIGHT or UP/DOWN button of axis that will move to second hard stop. Second Axis must be different than first Axis. Light will blink rapidly when hard stop is reached.

#### **MOVE TO PARK POSITION:**

Press and hold the LEFT/RIGHT or UP/DOWN buttons to move monitor to first point of park routine, press and release PARK button. Light will blink rapidly to acknowledge position.

Repeat until pattern is complete (up to 10 points).

Note: Both axis can be moved together to reach a point.

Press and hold PARK button until light turns off. Release button.

### 4.0.4.2 PARK PROGRAMMING EXAMPLE

- Press and hold PARK button until light blinks.
- Press and release UP button, monitor will move until hard stop reached. (light blinks rapidly.)
- Press and release RIGHT button, monitor will move until hard stop reached. (light blinks rapidly.)
- Press LEFT button to move 45 degrees, Press and release PARK button. (light blinks rapidly.)
- Press DOWN button to move 90 degrees, Press & release PARK button. (light blinks rapidly.)
- Press and hold PARK button until light turns off.

### 4.0.4.3 SELECTING NOZZLE DIRECTION DURING PARK

By default, the nozzle will move to the full straight stream position.

To select nozzle movement to the full fog position during PARK pattern, do the following:

- Enter PARK programming mode as indicated in section 4.0.4.2
- Once PARK light is flashing, Press FOG button for 1 second and release.
- Continue with PARK pattern programming as outlined in section 4.0.4.2.

To change back to the full straight stream position during PARK pattern, do the following:

- Enter PARK programming mode as indicated in section 4.0.4.2.
- Once PARK light is flashing, Press STRAIGHT STREAM button for 1 second and release.
- Continue with PARK pattern programming as outlined in section 4.0.4.2.

## 4.0.5 OSCILLATE FEATURE

The OSCILLATE feature allows the user to program a repeating pattern to control the horizontal and vertical axes of the monitor. Pressing any other button will stop the OSCILLATE pattern.

A label is supplied with each operator station that can be mounted on or near the station as a reminder of how to program the OSCILLATE pattern. The OSCILLATE pattern needs to be programmed before use. The pattern will be cleared each time power is cycled to the monitor. For fixed monitors, the monitor may be configured to store the program permanently. See Section 4.0.5.2.

**NOTE:** Depending on the manufactured date, it may be necessary to deploy the Extend-A-Gun in order to enter OSCILLATE programming mode.

### 4.0.5.1 PROGRAMMING

- Move monitor to starting point of pattern.
- Press and hold OSC button (~5 seconds) until light blinks. Release button. Light will continue to blink while in program mode.
- Move monitor to second point, press and release OSC button. Light will blink rapidly to acknowledge position.
- Repeat until pattern is complete (up to 65 points).
- Press and hold OSC button until light turns off. Release button.

<p><b>TO OSCILLATE:</b> Press &amp; release OSC button. (Pattern must be programmed first.)</p>	<p><b>TO PARK:</b> Press &amp; release PARK button. (Programmable, refer to manual.)</p>
---	--



**OSCILLATE PATTERN PROGRAMMING:**

- 1) Move monitor to starting point of pattern.
- 2) Press & hold OSC button until LED blinks. LED will continue to blink in program mode.
- 3) Move monitor to 2nd point, press OSC button. LED will blink rapidly to acknowledge position.
- 4) Repeat until pattern is complete.
- 5) Press & hold OSC button until LED turns off.

**NOTE: PATTERN WILL BE CLEARED UPON POWER LOSS.**

**800-348-2686**  
[www.tft.com](http://www.tft.com)

Figure 4.0.5.1  
Oscillate Programming Label

### 4.0.5.2 OSCILLATE PATTERN RETAIN FEATURE (DIP #4)

The monitor can be configured so that upon power down, the OSCILLATE pattern is retained. The OSCILLATE pattern must be programmed at least one time (see section 4.0.5.1). To enable the OSCILLATE pattern retain feature follow these steps:

1. Ensure power is OFF to the unit.
2. Remove lid from monitor operator station or control box.
3. Locate DIP switches on communication board.
4. Slide DIP switch #4 to the ON position.
5. Verify rubber seal is clean and undamaged. Verify that no wires are caught between lid and box. Replace lid.
6. Program OSCILLATE pattern.

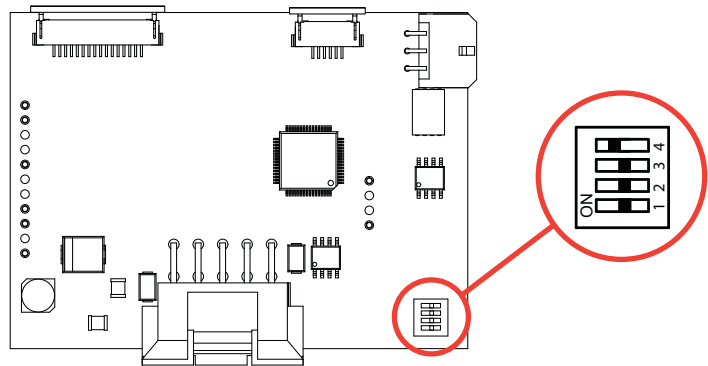

Figure 4.0.5.2  
Tornado, Hurricane, Typhoon, Monsoon, Tsunami Monitor  
Oscillate Pattern Retain Setup

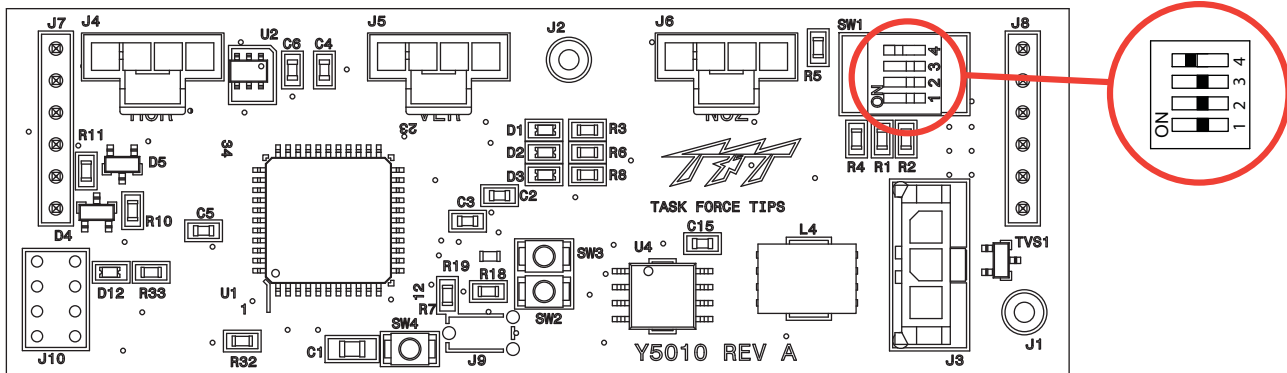
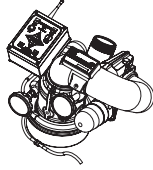

Figure 4.0.5.2B  
EF1 Monitor Oscillate Pattern Retain Setup

## 4.0.6 OVERRIDE KNOBS

In the event of electrical system failure on the monitor or fire apparatus, the TFT RC Monitor is factory supplied with override knobs so the monitor may be manually operated. If desired, the override knobs may be removed. The drive shafts have a hex so a wrench or socket may be used for manual override.

## 4.1 MONITOR MOUNTED OPERATOR STATION



This operator station is factory installed and wired to the monitor. It allows the monitor to be controlled at the monitor location.

### 4.1.1 MOUNTING

Operator station is factory installed on the monitor and requires no additional mounting.

### 4.1.2 ELECTRICAL WIRING

See fig. 4.0 for typical connections. The wiring on the monitor and for this operator station is factory installed. The assembly is supplied with a cable for connection to the other operator control stations. The cable has 4-conductors which supply power and the communications from the operator stations to the monitor.

### 4.1.3 CONNECTING DIRECTLY TO PROTECTED POWER SUPPLY

The electric RC monitor has an operator station, which is fully functional, mounted on the monitor. If no other operator stations are selected, with the exception of the wireless radio remote, the installer will only need to connect power to complete the installation. Route cable from monitor and connect to a protected circuit from the truck's power distribution center. Connect the red wire to positive and the black wire to negative (ground). Cut and discard blue and white wires.

### 4.1.4 OPERATION

This operator station is factory installed on the monitor and is used by personnel at the monitor. See Figure 4.0.1 for button operation.

## 4.2 PANEL MOUNT OPERATOR STATION (Y4E-RP)



This operator station allows the monitor to be controlled from a remote location. The installer will need to mount the operator station and connect the cable to the monitor and power. The enclosure is designed to be recessed mounted in a panel.

This operator station has extra power and communication terminal blocks available and can be used as a central location for terminating wires. In this type of installation the monitor cable, the power cable, and possibly other operator station cables could be installed into this operator station. On the back of this enclosure are extra strain relief fittings.

In many installations this operator station will also include the wiring connections for the joystick, Canbus output module or installer supplied toggle switches. A terminal block is available for “UP, DOWN, LEFT, RIGHT, FOG, SS, PARK” inputs. The circuit board in this operator station is factory configured to accept +12/24 volt DC inputs input signals but can be field changed to accept ground input signals.

### 4.2.1 MOUNTING

Select proper operator location. Panel space required will be 5" x 7-1/4" (127 x 185mm). A depth of 2" (50mm) will be required behind the panel. Refer to Figure 4.2.1 for cutout dimensions. Allow at least 6" of slack in cable for future repairs.

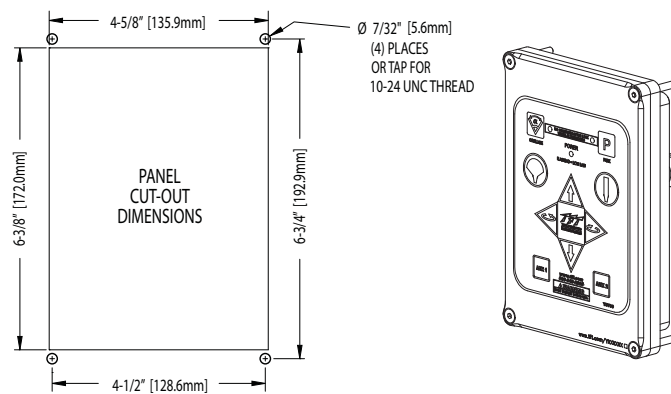
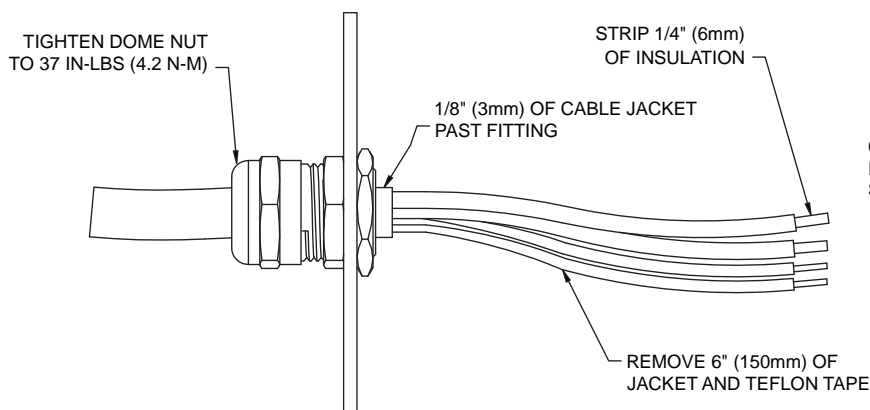

Figure 4.2.1  
Panel Mount Operator Station Cutout Dimensions

### 4.2.2 ELECTRICAL WIRING

See figure 4.0 for typical connections. The 4-conductor cable from the operator station needs to be connected to power (red & black) and to the communication link (blue & white) from the monitor. Refer to Figure 4.2.2 for typical cable preparation. Be sure to tighten all terminal block screws securely.



**NOTE:**  
CABLE IS GEL FILLED TO PREVENT MOISTURE WICKING INTO ENCLOSURE. GEL IS NON-HAZARDOUS AND SHOULD BE WIPED OFF CONDUCTORS WITH A RAG.

Fig 4.2.2  
Typical Cable Preparation

### 4.2.3 INPUTS SIGNAL CONFIGURATION

The Panel Mount Operator Station is shipped from the factory configured to accept +12/24 volt DC input signals, but can be field changed to accept ground input signals. To change the configuration:

1. Ensure power is OFF to the unit.
2. Remove lid from enclosure.
3. Locate DIP switches on communication board.
4. Slide DIP switch #4 to the OFF position to select GROUND inputs or slide to the ON position to select VOLTAGE inputs.
5. Verify rubber seal is clean and undamaged. Verify that no wires are caught between lid and box. Replace lid.

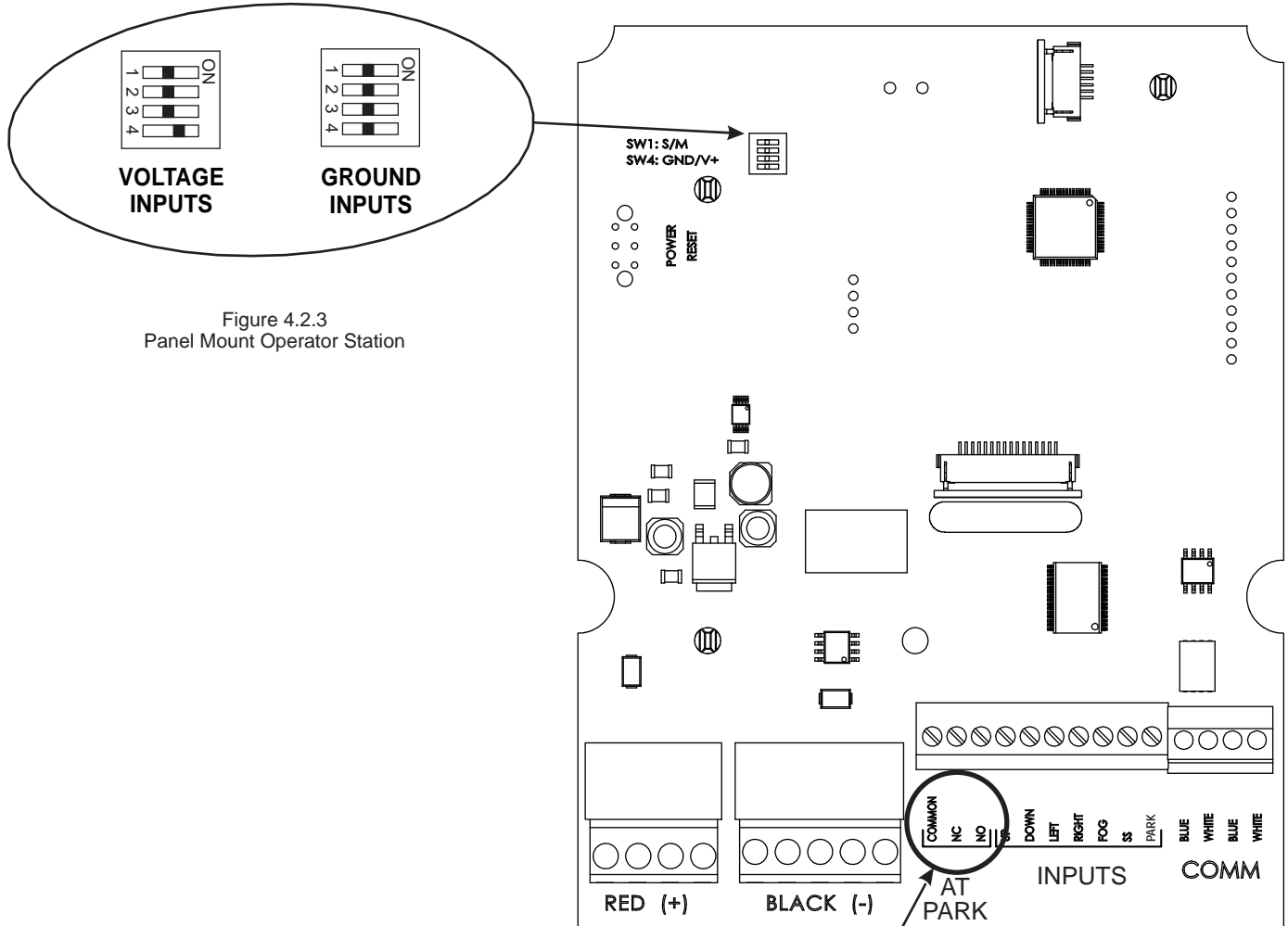

Figure 4.2.3  
Panel Mount Operator Station

### AT PARK RELAY USER TERMINALS

Figure 4.2.4  
Relay / Terminal Location

### 4.2.4 PANEL MOUNT OPERATOR STATION WITH AT PARK RELAY (Y4E-RP)

The Panel Mount Operator Station provides feedback for the user that the monitor is in the AT PARK position. The Operator station contains a circuit board that is equipped with a relay that is energized when the monitor is in use and de-energized when the monitor reaches its final PARK location. The contact rating of the relay is 1 amp @ 30VDC for resistive loads and 0.2 amps @ 30VDC for inductive loads.

The AT PARK relay has one Form-C contact (common, normally open, normally closed) that can be used. The figure above shows the terminal blocks available for user wiring.

### 4.2.5 OPERATION

This operator station is installed on the truck, for example the pump operator's panel. It is used to operate the monitor from a location on the truck. See Figure 4.0.1 for button operation.

### 4.3 PANEL MOUNT OPERATOR STATION WITH DISPLAY (Y4E-RP-D)



This operator station allows the monitor to be controlled from a remote location. The installer will need to mount the operator station and connect the cable to the monitor and power. The enclosure is designed to be mounted on top of a panel control station.

This operator station has an extra power and communication connection point available and can be used as a central location for terminating wires from the monitor. In this type of installation the monitor cable and the power cable could be installed into this operator station. On the back of this enclosure are extra strain relief fittings.

#### 4.3.1 MOUNTING

Select proper operator location. Panel space required will be 5" x 7-1/4" (127 x 185mm). A depth of 2" (50mm) will be required behind the panel. Refer to Figure 4.3.1 for cutout dimensions. Allow at least 6" of slack in cable for future repairs. Refer to figure 4.2.1 for cutout dimensions.

#### 4.3.2 ELECTRICAL WIRING

See Figure 4.0 for typical connections. The 4-conductor cable from the operator station needs to be connected to power (red & black) and to the communication link (blue & white) from the monitor. Be sure to tighten all terminal block screws securely. Refer to figure 4.2.2 for typical cable preparation.

#### 4.3.3 PANEL MOUNT OPERATOR STATION WITH DISPLAY AT PARK RELAY

The Panel Mount Operator Station provides feedback for the user that the monitor is in the AT PARK position. The Operator station contains a circuit board that is equipped with a relay that is energized when the monitor is in use and de-energized when the monitor reaches its final PARK location. The contact rating of the relay is 1 amp @ 30VDC for resistive loads and 0.2 amps @ 30VDC for inductive loads.

The AT PARK relay has one Form-C contact (common, normally open, normally closed) that can be used. The figure below shows the terminal blocks available for user wiring.

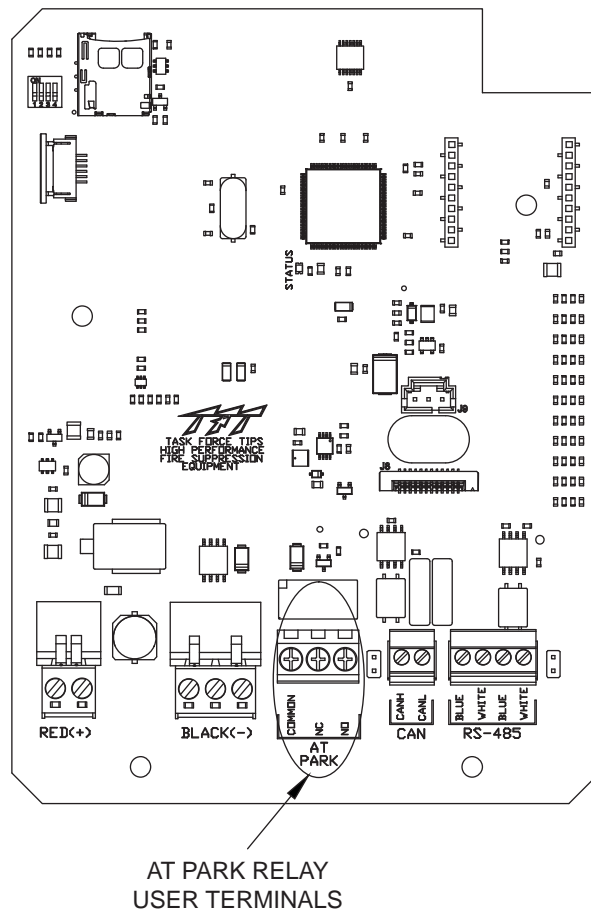

AT PARK RELAY  
USER TERMINALS

Figure 4.3.3  
Relay Terminal Block Location

### 4.3.4 CONTROLLER AREA NETWORK (CAN) COMMUNICATION BUS

This operator station includes a connection header to communicate across a J1939 CAN bus system and allows control of TFT RC Monitors and TFT RC Valve Under Monitors when a YE-CAN# Multiplex Interface Control is installed (refer to section 4.14).

#### 4.3.4.1 CAN WIRING CONFIGURATION

The Y4E-RP-D operator station needs to have the communication bus wiring relocated from the RS-485 communication bus terminal block to the CAN communication bus terminal block. Refer to Figure 4.3.4.1

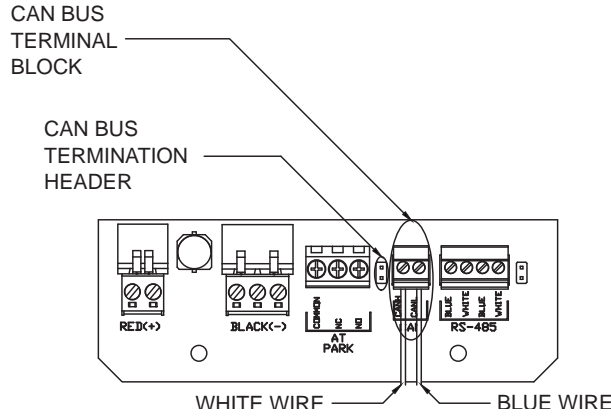

Figure 4.3.4.1  
Operator Station CAN bus wiring configuration

#### 4.3.4.2 CAN BUS TERMINATION

The CAN communication bus must be terminated as per the ISO 11898-2 Controller Area Network Standard. Optionally, the bus can be terminated inside the Y4E-RP-D operator station by shorting the CAN BUS TERMINATION HEADER, refer to Figure 4.3.4.1 for the location of the header. There are many standard shunts that can be used to short the Termination Header. TE Connectivity part number 881545-2 is one example of a compatible shunt for this Termination Header.

#### 4.3.5 BASIC OPERATION

This operator station is installed on the truck, for example, on the pump operator's panel. It is used to operate a TFT RC monitor from a location directly mounted on the truck. This operator station gives the user full control of the monitor including the PARK, OSCILLATE, and any AUXILIARY functions. See Figure 4.0.1 for button operation.

#### 4.3.6 DISPLAY CONTROLLED OPERATION

This operator station includes 3 buttons that are located just below the display screen that initiate control and configuration options of the operator station based on the display screen text located in the bottom area of the screen. Detailed information on this display driven control of the operator station can be found in the Remote Monitor Operator Station with Display User's Guide (LIY-425) that is included with the operator station. This User's Guide is also located on TFT's website.

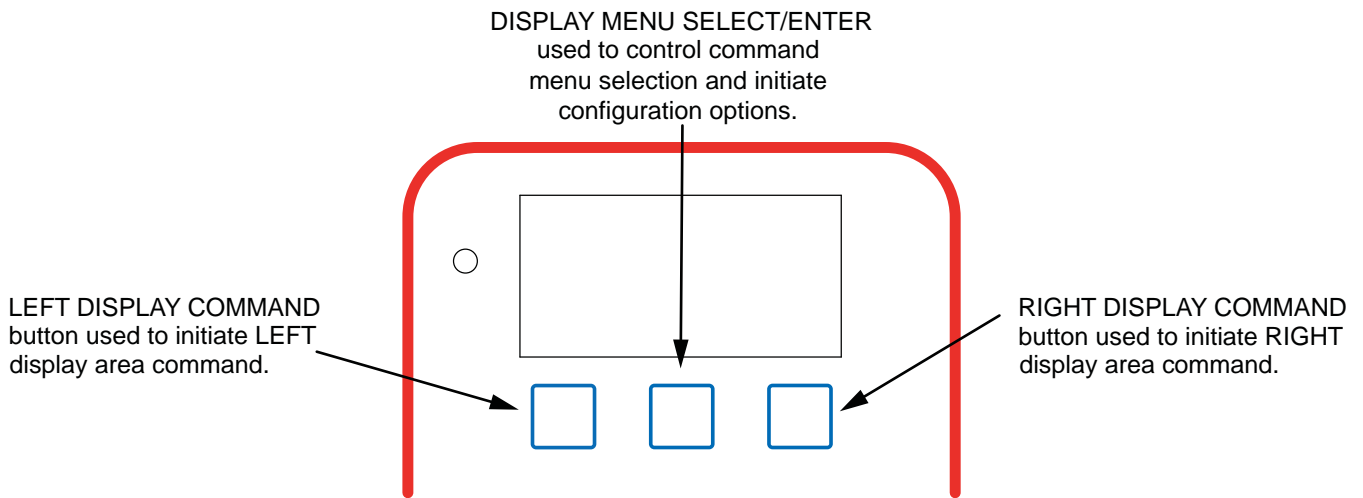
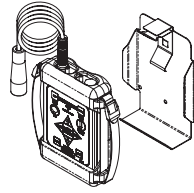

Figure 4.3.6  
Operator Station with Display Control Pad

## 4.4 TETHERED OPERATOR STATION (Y4E-CT-##)



This operator station will have a factory installed 4-conductor cable, which will act as a tether, with a plug on the end. The installer will need to mount the storage bracket and receptacle.

### 4.4.1 MOUNTING STORAGE BRACKET

The storage bracket is supplied with (3) 1/4-20 stainless steel self-tapping screws. Make sure the material beneath the bracket is substantial and thick enough to hold self-tapping screws. Make sure the area on the backside of the mounting surface is clear of obstructions. We recommend a minimum thickness of 3/32" (.093" - 2.4 mm) in aluminum and 5/64 (.078"-2mm) in steel. See the chart in Figure 4.4.1 to determine the correct pilot hole size.

Select proper location for mounting storage bracket. Panel space required will be 6.0" x 11.2" (152 x 285mm). Refer to Figure 4.4.1 for hole dimensions. Bracket can be used as a template. **Be sure spring is in position.**

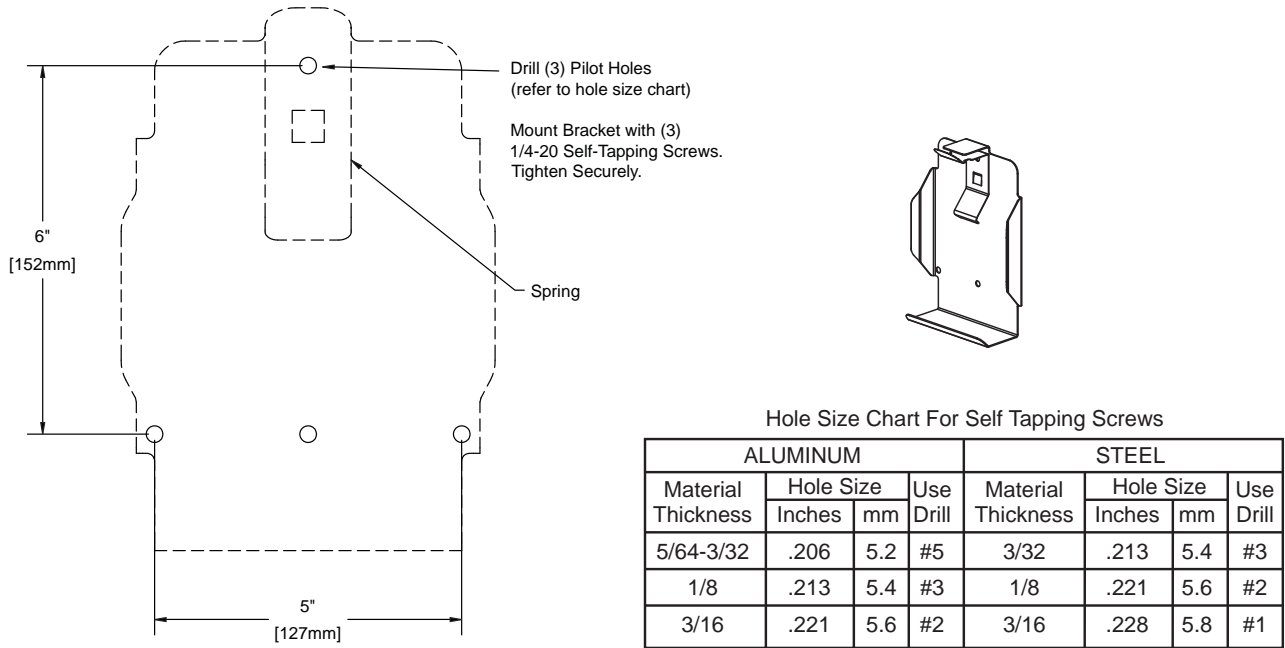

Figure 4.4.1  
Tethered Operator Station Storage Bracket Hole Dimensions

### 4.4.2 RECEPTACLE MOUNTING

Select proper location for mounting receptacle. Receptacle is 1-1/4" x 1-1/4" and 1/2" deep. (32 mm x 32 mm x 13 mm) Allow extra room behind receptacle for wires. Refer to Figure 4.4.2 for hole dimensions.

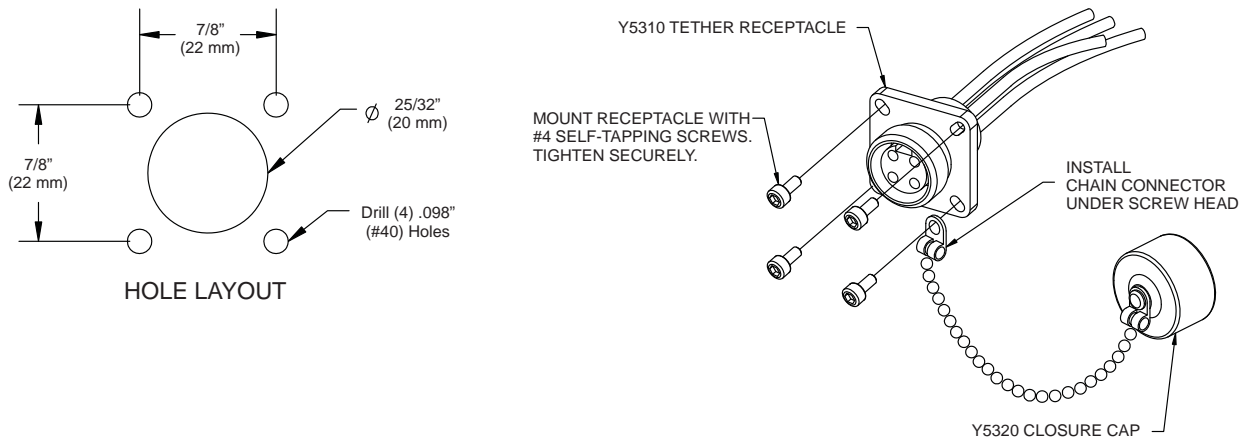

Fig 4.4.2  
Tether Operator Station Receptacle Hole Dimensions



### **4.4.3 ELECTRICAL WIRING**

See figure 4.0 for typical connections. The 4-conductor cable from the receptacle needs to be connected to power (red & black) and to the communication link (blue & white) from the monitor. Refer to Figure 4.2.2 for typical cable preparation.

### **4.4.4 OPERATION**

This operator station is tethered to the truck with a 10 foot (3 meter), 30 foot (9 meter), or 100 foot (30 meter) cable. It is used to move slightly away from the truck to get a better view for redirecting the monitor. This operator station gives the user full control of the monitor including the PARK, OSCILLATE, and any AUXILIARY functions. See Figure 4.0.1 for button operation.

## 4.5 TETHERED OPERATOR STATION WITH DISPLAY (Y4E-CT-##-D)

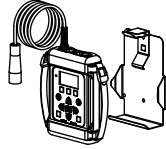

This operator station will have a factory installed 4-conductor cable, which will act as a tether, with a plug on the end. The installer will need to mount the storage bracket and receptacle.

### 4.5.1 MOUNTING STORAGE BRACKET (see section 4.4.1)

The storage bracket is supplied with (3) 1/4-20 stainless steel self-tapping screws. Make sure the material beneath the bracket is substantial and thick enough to hold self-tapping screws. Make sure the area on the backside of the mounting surface is clear of obstructions. We recommend a minimum thickness of 3/32" (.093" - 2.4 mm) in aluminum and 5/64 (.078"-2mm) in steel See the chart in Figure 4.4.1 to determine the correct pilot hole size.

Select proper location for mounting storage bracket. Panel space required will be 6.0" x 11.2" (152mm x 285mm). Refer to Figure 4.5.1 for hole dimensions. Bracket can be used as a template. Be sure spring is in position.

### 4.5.2 RECEPTACLE MOUNTING (see section 4.4.2)

Select proper location for mounting receptacle. Receptacle is 1-1/4" x 1-1/4" and 1/2" deep. (32 mm x 32 mm x 13 mm) Allow extra room behind receptacle for wires. Refer to Figure 4.4.2 for hole dimensions.

### 4.5.3 ELECTRICAL WIRING

See figure 4.0 for typical connections. The 4-conductor cable from the receptacle needs to be connected to power (red & black) and to the communication link (blue & white) from the monitor. Refer to Figure 4.2.2 for typical cable preparation.

### 4.5.4 CONTROLLER AREA NETWORK (CAN) COMMUNICATION BUS

This operator station includes connection headers to communicate across a J1939 CAN bus system and allows control of TFT RC Monitors and TFT RC Valve Under Monitors when a YE-CAN# Multiplex Interface Control is installed (refer to section 4.14).

#### 4.5.4.1 CAN WIRING CONFIGURATION

The Y4E-CT-##-D operator station needs to have the communication bus wiring relocated from the RS-485 communication bus terminal block to the CAN communication bus terminal block. Refer to Figure 4.3.4.1.

#### 4.5.4.2 CAN BUS TERMINATION

The CAN communication bus must be terminated as per the ISO 11898-2 Controller Area Network Standard. Optionally, the bus can be terminated inside the Y4E-CT-##-D operator station by shorting the CAN BUS TERMINATION HEADER, refer to Figure 4.5.4.1 for the location of the header. There are many standard shunts that can be used to short the Termination Header. TE Connectivity part number 881545-2 is one example of a compatible shunt for this Termination Header.

### 4.5.5 BASIC OPERATION

This operator station is tethered to the truck with a 10 foot (3 meter), 30 foot (9 meter), or 100 foot (30 meter) cable. It is used to move slightly away from the truck to get a better view for redirecting the monitor. This operator station gives the user full control of the monitor including the PARK, OSCILLATE, and any AUXILIARY functions. See Figure 4.0.1 for button operation.

### 4.5.6 DISPLAY CONTROLLED OPERATION

This operator station includes 3 buttons that are located just below the display screen that initiate control and configuration options of the operator station based on the display screen text located in the bottom area of the screen. Detailed information on this display driven control of the operator station can be found in the Remote Monitor Operator Station with Display User's Guide (LIY-425) that included with the operator station. This User's Guide is also located on TFT's website. See Section 4.3.6 for display button operation.

## 4.6 WIRELESS OPERATOR STATION (YE-RF-##)

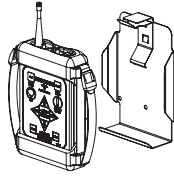

The YE-RF-## Wireless Operator Station is supplied with a radio board that needs to be installed in the monitor control box and a storage bracket.

### 4.6.1 MOUNTING STORAGE BRACKET (see section 4.4.1)

The storage bracket is supplied with (3) 1/4-20 stainless steel self-tapping screws. Make sure the material beneath the bracket is substantial and thick enough to hold self-tapping screws. Make sure the area on the backside of the mounting surface is clear of obstructions. We recommend a minimum thickness of 3/32" (.093" - 2.4 mm) in aluminum and 5/64 (.078"-2mm) in steel. See the chart in Figure 4.6.1 to determine the correct pilot hole size.

Select proper location for mounting storage bracket. Panel space required will be 6.0" x 11.2" (152 x 285mm). Refer to Figure 4.4.1 for hole dimensions. Bracket can be used as a template. Be sure spring is in position.

### 4.6.2 INSTALLING RADIO/ANTENNA

Turn off power and remove lid from monitor control box. Be careful to open lid slowly as lid will be connected to the communication board by a flat cable.

#### ANTENNA

- (1) Ensure power is OFF to the unit.
- 2) Remove hex plug (if installed) from side of control box.
- 3) Install antenna fitting and nut with Red Loc-tite® thru hole.

#### RADIO

- 1) Unplug connector with blue & white wires and remove the small communication board on the far left.
- 2) Attach antenna connector to radio board with the cable in the orientation shown in Fig 4.6.2a. **Note: In some RC monitors, cable tie may need to be cut to attach antenna.**
- 3) Plug radio board into communication board. (Fig 4.6.2b) Be careful to line up pins.
- 4) Plug communication board/radio board into main board. Press down to seat securely.
- 5) Insert connector with blue & white wires into communication board.

Replace lid onto box. Be sure to guide flat cable down onto motor boards and to not pinch any wires between lid and box.

Tighten lid screws equally in a criss-cross pattern.

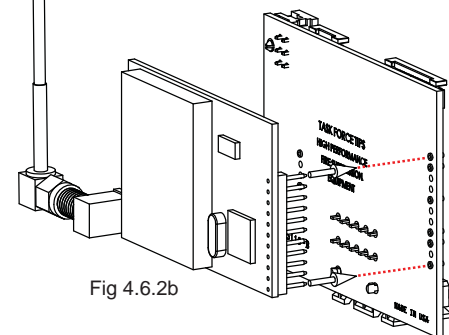
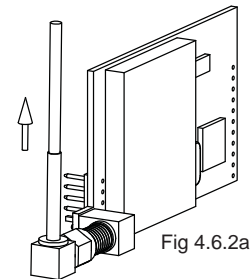

### 4.6.3 TEACHING ID CODE:

**NOTE: When the operator station is purchased at the same time as the RC monitor, handheld unit will be pre-taught at factory.**

**NOTE: Before teaching, monitor should be powered down.**

**NOTE: If multiple monitors are present, apply power only to the monitor being taught, otherwise possible conflicts may occur.**

Every monitor has a unique ID code that must be "taught or transferred" to the wireless handheld unit. This unique ID code allows multiple monitors to be used in one location without interference. Perform the following procedure to teach the handheld unit.

#### On Wireless Handheld Unit:

- Press POWER button to turn on electronics.
- Press and hold both LEFT & RIGHT buttons simultaneously for 5 seconds.
- Continue to press the LEFT & RIGHT buttons and then press UP button for 2 seconds.
- Release buttons. After several seconds the OSC & PARK lights will flash rapidly to indicate that the unit is in teach mode.

#### On Monitor Control Box:

- Apply power to monitor.
- Press and hold both LEFT & RIGHT buttons simultaneously for 5 seconds.
- Continue to press the LEFT & RIGHT buttons and then press UP button for 2 seconds.
- Release buttons. After several seconds the OSC & PARK lights will flash rapidly to indicate that the unit is in teach mode. ID code is automatically transferred to the wireless handheld unit.
- OSC & PARK lights on handheld unit will stop flashing after ID code is transferred.
- Press DOWN button on monitor control box to exit teach mode.
- Cycle power off and back on to monitor.

In the event the handheld unit does not link up with the monitor, perform the following at the monitor operator station and the handheld unit.

- Turn off power.
- Press and hold DOWN button.
- Apply power to the monitor, continue to hold DOWN button for 3 seconds.
- Release DOWN button.
- After green POWER light stops blinking, test wireless handheld unit.
- Repeat above procedure for "Teaching ID Code"

#### 4.6.4 CHANGING BATTERIES:

##### Four (AA) Batteries, Lithium Recommended

- Remove two (2) screws on backside of handheld unit and slide bottom half of rubber bumper off enclosure.
- Replace batteries verifying that polarity is correct.
- Replace rubber bumper and retaining screws.

### NOTICE

**Properly dispose of old batteries. Do not puncture, incinerate, or disassemble batteries. Do not mix battery types.**

#### 4.6.5 OPERATION

The Wireless Operator Station allows a user to move away from the truck to get a better view for redirecting the monitor. This operator station gives the user full control of the monitor including the PARK, OSCillate, and any AUXiliary functions. For TFT RC monitors shipped with the antenna pre-mounted in the monitor control box, all the user needs to do is mount the storage bracket, install radio board in monitor, and teach the ID code to the handheld unit. See Figure 4.0.1 for button operation.

The range of the wireless operator station is 500 ft (152 m) and the handheld unit is powered by four (4) AA batteries, lithium batteries are recommended. Lithium batteries will provide 33 hours of continuous operation. When the battery voltage is low, the POWER light will begin to flash. At this point there are approximately 3 hours of continuous operation remaining.

The handheld unit will automatically turn off after 5 minutes if no buttons are pressed.

- Press POWER button to turn on electronics.
- Use operator station just like any other wired operator station.
- Press POWER button again to turn off electronics or after 5 minutes of idle operation, handheld unit will automatically turn off.

**NOTE!!!** If after pressing a button, the OSC & PARK lights alternately flash, this indicates no communication link is present with the monitor. The handheld unit is out of range or cannot establish a link with the monitor. Move to a different location and then retry, also verify monitor has power applied.

## 4.7 WIRELESS OPERATOR STATION WITH DISPLAY (YE-RF-##-D)

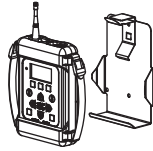

The YE-RF-##-D Wireless Operator Station is supplied with a radio board that needs to be installed in the monitor control box and a storage bracket. No additional wiring is required.

### 4.7.1 MOUNTING STORAGE BRACKET (see section 4.4.1)

The storage bracket is supplied with (3) 1/4-20 stainless steel self-tapping screws. Make sure the material beneath the bracket is substantial and thick enough to hold self-tapping screws. Make sure the area on the backside of the mounting surface is clear of obstructions. We recommend a minimum thickness of 3/32" (.093" - 2.4 mm) in aluminum and 5/64" (.078"-2mm) in steel. See the chart in Figure 4.7.1 to determine the correct pilot hole size.

Select proper location for mounting storage bracket. Panel space required will be 6.0" x 11.2" (152mm x 285mm). Refer to Figure 4.7.1 for hole dimensions. Bracket can be used as a template. Be sure spring is in position.

### 4.4.2 INSTALLING RADIO/ANTENNA (see section 4.6.2)

Turn off power and remove lid from monitor control box. Be careful to open lid slowly as lid will be connected to the Communication board by a flat cable.

### 4.7.3 BASIC OPERATION

The Wireless Operator Station allows a user to move away from the truck to get a better view for redirecting the monitor. This operator station gives the user full control of the monitor including the PARK, OSCILLATE, and any AUXILIARY functions. For TFT RC monitors shipped with the antenna pre-mounted in the monitor control box, all the user needs to do is mount the storage bracket, install radio board in the monitor, and teach the ID code to the handheld unit. See Figure 4.0.1 for button operation.

The range of the wireless operator station is 500 ft (152 m) and the handheld unit is powered by four (4) AA batteries, lithium batteries are recommended. Lithium batteries will provide over 24 hours of continuous operation. When the battery voltage is low, the System Status area located at the top of the display will begin flashing a "LOW BATTERY" message. At this point there are approximately 2 hours of continuous operation remaining.

The handheld unit will automatically turn off after 5 minutes if no buttons are pressed.

- Press POWER button to turn on electronics.
- Use operator station just like any other wired operator station.
- Press POWER button again to turn off electronics, or after 5 minutes of idle operation, the handheld unit will automatically turn off.

**NOTE!!!** If after pressing a button a "COMMUNICATION ERROR" message flashes in the System Status area, no communication link is present with the monitor. The handheld unit is out of range or cannot establish a link with the monitor. Move to a different location and then retry, also verify the monitor has power applied.

### 4.7.4 DISPLAY CONTROLLED OPERATION

This operator station includes 3 buttons that are located just below the display screen that initiate control and configuration options of the operator station based on the display screen text located in the bottom area of the screen. Detailed information on this display driven control of the operator station can be found in the Remote Monitor Operator Station with Display User's Guide (LIY-425) that included with the operator station. This User's Guide is also located on TFT's website. See section 4.3.6 for Display button operation.

#### 4.7.5 TEACHING ID CODE:

**NOTE:** When the operator station is purchased at the same time as the RC monitor, handheld unit will be pre-taught at factory.

**NOTE:** Before teaching, monitor should be powered down.

**NOTE:** If multiple monitors are present, apply power only to the monitor being taught, otherwise possible conflicts may occur.

Every monitor has a unique ID code that must be “taught or transferred” to the wireless handheld unit. This unique ID code allows multiple monitors to be used in one location without interference. Perform the following procedure to teach the handheld unit.

##### Learn ID Code Wireless Handheld Unit with Display:

- 1) Press POWER button to turn on wireless handheld operator station.
- 2) Press and hold DISPLAY MENU SELECT/ENTER button for 5 seconds to enter the configuration menu.
- 3) Once in the configuration menu, release the DISPLAY MENU SELECT/ENTER button, and then repeatedly press the DISPLAY MENU SELECT/ENTER button until “RFID LEARN” is displayed in the command options and press the corresponding DISPLAY COMMAND button.
- 4) The display screen will indicate the status of the RFID TEACH/LEARN sequence and will automatically exit TEACH/LEARN mode when receiving a new ID.

##### Teach ID Code On Monitor Control Box:

- 1) Apply power to monitor.
- 2) Press and hold both LEFT & RIGHT buttons simultaneously for 5 seconds.
- 3) Continue to press the LEFT & RIGHT buttons and then press UP button for 2 seconds.
- 4) Release buttons. After several seconds the OSC & PARK lights will flash rapidly to indicate that the unit is in teach mode. ID code is automatically transferred to the wireless handheld unit.
- 5) Display screen on handheld unit will display a “PROGRAMMING COMPLETE” message and automatically exit the ID Code LEARN MODE after ID code is transferred.
- 6) Press DOWN button on monitor control box to exit teach mode.
- 7) Cycle power off and back on to monitor.

In the event the handheld unit does not link up with the monitor, perform the following at the monitor operator station and the handheld unit:

1. Turn off power.
2. Press and hold DOWN button.
3. Apply power to the monitor and continue to hold DOWN button for 3 seconds.
4. Release DOWN button.
5. After green POWER light stops blinking, test wireless handheld unit.
6. Repeat above procedure for “Learn ID Code” and “Teaching ID Code”

## 4.7.6 CONFIGURATION OF MULTIPLE MONITOR CONTROL

This monitor operator station can be configured to control up to ten (10) monitors from a single controller. Follow the steps below to configure a system to have multiple monitors controlled from a single Wireless Operator Station with Display. Please refer to Remote Monitor Operator Station with Display User's Guide (LIY-425) for more detailed information on display screen usage and unit configuration.

### 4.7.6.1 TEACHING ID CODE TO MULTIPLE MONITORS AND WIRELESS UNIT

#### Select a Primary Monitor

Any monitor can be used as the primary monitor. The main purpose for selecting a primary monitor is to use the wireless ID code to teach to all the other monitors as well as the wireless handheld operator station.

#### Learn ID Code Wireless Handheld Unit with Display:

- 1) Press POWER button to turn on wireless handheld operator station.
- 2) Press and hold DISPLAY MENU SELECT/ENTER button for 5 seconds to enter the configuration menu.
- 3) Once in the configuration menu, release the DISPLAY MENU SELECT/ENTER button, and then repeatedly press the DISPLAY MENU SELECT/ENTER button until "RFID LEARN" is displayed in the command options and press the corresponding DISPLAY COMMAND button.
- 4) The display screen will indicate the status of the RFID TEACH/LEARN sequence and will automatically exit TEACH/LEARN mode when receiving a new ID.

#### Learn ID Code on Monitor Control Box (non-primary monitors):

- 1) Apply power to monitor.
- 2) Press and hold both LEFT & RIGHT buttons simultaneously for 5 seconds.
- 3) Continue to press the LEFT & RIGHT buttons and then press DOWN button for 2 seconds.
- 4) Release buttons. After several seconds the OSC & PARK lights will flash rapidly to indicate that the unit is in LEARN mode, the blink pattern for LEARN mode is slightly different from TEACH mode.
- 5) Display screen on handheld unit will display a "PROGRAMMING COMPLETE" message and automatically exit the ID Code LEARN MODE after ID code is transferred.
- 6) OSC & PARK lights on the monitor(s) in LEARN mode will stop flashing after ID code is transferred.

#### Teach ID Code on Monitor Control Box (primary monitor only):

- 1) Apply power to monitor.
- 2) Press and hold both LEFT & RIGHT buttons simultaneously for 5 seconds.
- 3) Continue to press the LEFT & RIGHT buttons and then press UP button for 2 seconds.
- 4) Release buttons. After several seconds the OSC & PARK lights will flash rapidly to indicate that the unit is in teach mode. ID code is automatically transferred to the wireless handheld unit.
- 5) OSC & PARK lights on handheld unit will stop flashing after ID code is transferred.
- 6) Press DOWN button on monitor control box to exit teach mode.
- 7) Cycle power off and back on to monitor.

## 4.7.6.2 MONITOR GROUP CONFIGURATION

In a multiple monitor control system, all the wireless devices share the same ID code. Individual control of each monitor is then selected by configuring each monitor to only respond to control commands addressed to a specific "group". A monitor group consists of all equipment associated with water flow equipment and accessories associated with one specific monitor. This could include a TFT RC Monitor, RC Valve Under Monitor, and a RC Extend-A-Gun.

### Group Configuration on Wireless Handheld Unit with Display:

- 1) Press POWER button to turn on wireless handheld operator station.
- 2) Press and hold DISPLAY MENU SELECT/ENTER button for 5 seconds to enter the configuration menu.
- 3) Once in the configuration menu, repeatedly press and release the DISPLAY MENU SELECT/ENTER button until "GROUP CONFIG" is displayed in the command options and press the corresponding DISPLAY COMMAND button.
- 4) Select the number of monitors the wireless handheld unit will be configured to control. If only one monitor is selected then the configuration program will require the group number to assign to this controller.
- 5) After the number of monitors has been configured a name that is easier to remember can then be assigned to each group number.

### Group Configuration on Monitor(s)

- 1) Press POWER button to turn on wireless handheld operator station.
- 2) Select the monitor group number to assign to a monitor.
- 3) Apply power to monitor.
- 4) Press and hold both FOG & STRAIGHT STREAM buttons simultaneously for 5 seconds.
- 5) Continue to press the FOG & STRAIGHT STREAM buttons and then press DOWN button for 2 seconds, OSC light will begin to flash.
- 6) Release buttons. After several seconds the OSC will cease flashing indicating that it has learned a new group assignment.
- 7) Test operation by pressing direction control buttons on wireless handheld operator station.
- 8) Repeat this process for each of the other monitors that will be custom assigned group numbering.

## 4.7.7 CHANGING BATTERIES:

### Four (AA) Batteries, Lithium Recommended

- 1) Remove two (2) screws on backside of handheld unit and slide bottom half of rubber bumper off enclosure.
- 2) Replace batteries verifying that polarity is correct.
- 3) Replace rubber bumper and retaining screws.

## NOTICE

Properly dispose of old batteries. Do not puncture, incinerate, or disassemble batteries. Do not mix battery types.



## 4.8 JOYSTICK OPERATOR STATION (Y4E-JS-###)

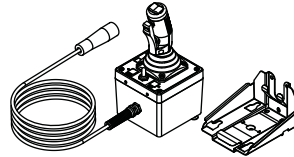

This operator station allows the monitor to be controlled by a joystick. The installer will need to mount the joystick control and connect the cable to a receptacle or terminal box with power and communication connections. The joystick control needs to be mounted in a weatherproof location, for example, inside the cab of the truck.

### 4.8.1 MOUNTING STORAGE BRACKET

The storage spring (A) and bracket (B) is supplied with (3) 1/4-20 stainless steel self-tapping screws (E). Make sure the material beneath the bracket is substantial and thick enough to hold self-tapping screws. Make sure the area on the backside of the mounting surface is clear of obstructions. A minimum thickness of 3/32" (.093" - 2.4 mm) in aluminum and 5/64" (.078" - 2mm) in steel is recommended. See the chart in Figure 4.8.1.1. The bracket can be mounted from the side (See Figure 4.5.1.4) or bottom (See Figure 4.8.1.5). When installed in the side configuration, (2) 1/4-20 button head cap screws (F) and (2) locking nuts (G) should be installed as shown in Figure 4.8.1.4.

Hole Chart For Self Tapping Screws							
ALUMINIUM				STEEL			
Material Thickness	Hole Size		Use Drill	Material Thickness	Hole Size		Use Drill
	Inches	mm			Inches	mm	
5/64-3/32	0.206	5.2	#5	5/64-3/32	0.206	5.2	#5
1/8	0.213	5.4	#3	1/8	0.213	5.4	#3
3/16	0.221	5.6	#2	3/16	0.221	5.6	#2

Fig 4.8.1.1  
Joystick Operator Station Hole Dimensions

Install joystick instruction label nearby for quick operation reference.

**\*SMART STREAM FOG THEN FLUSH\***      FOG      STRAIGHT STREAM

1) NOZZLE STOPS AT FULL FOG  
2) PRESS AGAIN FOR FLUSH



**TO OSCILLATE:**  
Press & release OSC button.  
(Pattern must be programmed first.)

**TO PARK:**  
Press & release PARK button.  
(Programmable, refer to manual.)

**OSCILLATE PATTERN PROGRAMMING:**

- 1) Move monitor to starting point of pattern.
- 2) Press & hold OSC button until LED blinks. LED will continue to blink in program mode.
- 3) Move monitor to 2nd point, press OSC button. LED will blink rapidly to acknowledge position.
- 4) Repeat until pattern is complete.
- 5) Press & hold OSC button until LED turns off.

*NOTE: PATTERN WILL BE CLEARED UPON POWER LOSS.*

**TFT**  
TASK FORCE TIPS  
FIRE FIGHTING EQUIPMENT

Where New Ideas Flow™ • 800-348-2686 • www.tft.com      Y5336

Fig 4.8.1.2  
Joystick Instruction Label

## KEY INSTALLATION

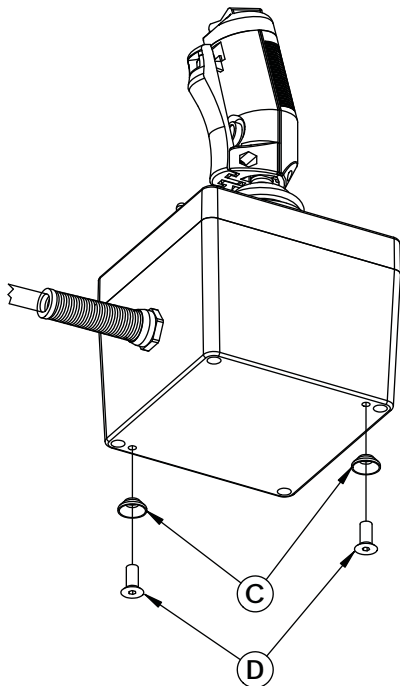

Fig 4.8.1.3

ID	DESCRIPTION	QTY	ORDER #
A	LATCH SPRING	1	Y7032
B	MOUNTING BRACKET	1	Y7031
C	KEY	2	Y7033
D	1/4-20 X 1/2 FLAT HEAD CAP SCREW	2	VT25-20FH500
E	1/4-20 X 3/4 SELF TAPPING HEX SCREW	3	VT25-20HX750
F	1/4-20 X 3/8 BUTTON HEAD CAP SCREW	2	VT25-20BH375
G	1/4-20 LOCKING NUT	2	VT25-20LNT

### SIDE MOUNTING OPTION

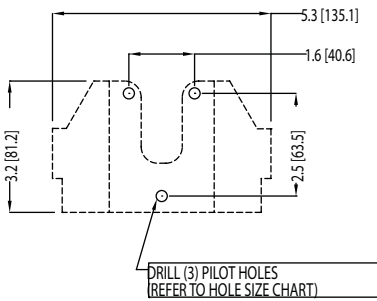
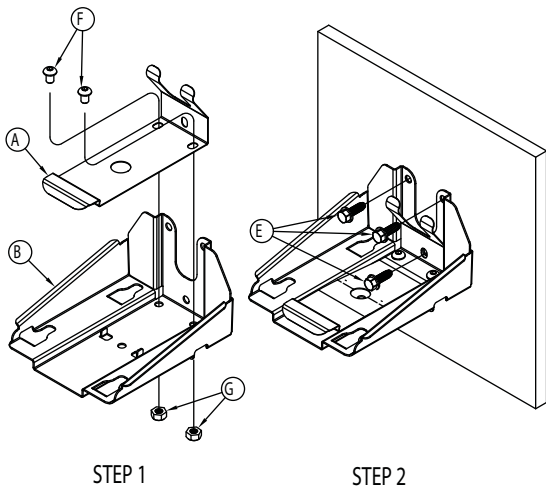

Fig 4.8.1.4  
Bracket Side Mounting Option

### BOTTOM MOUNTING OPTION

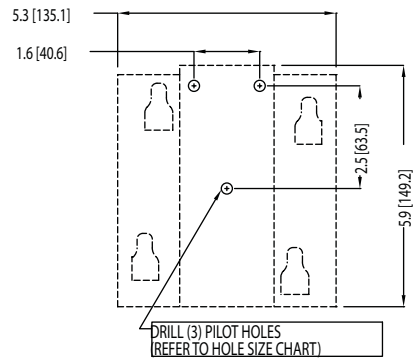
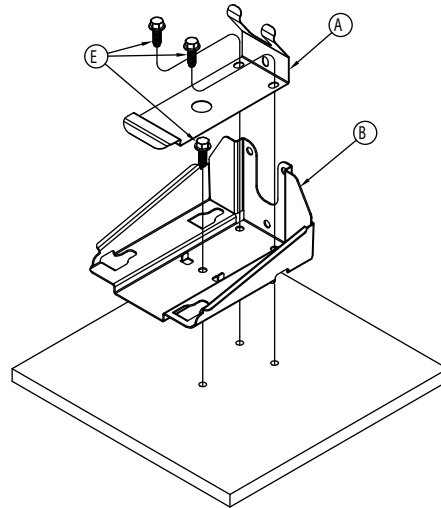

Fig 4.8.1.5  
Bracket Bottom Mounting Option

## 4.8.2 OPERATION

This operator station is installed in a protected location and allows the monitor to be controlled by a joystick.

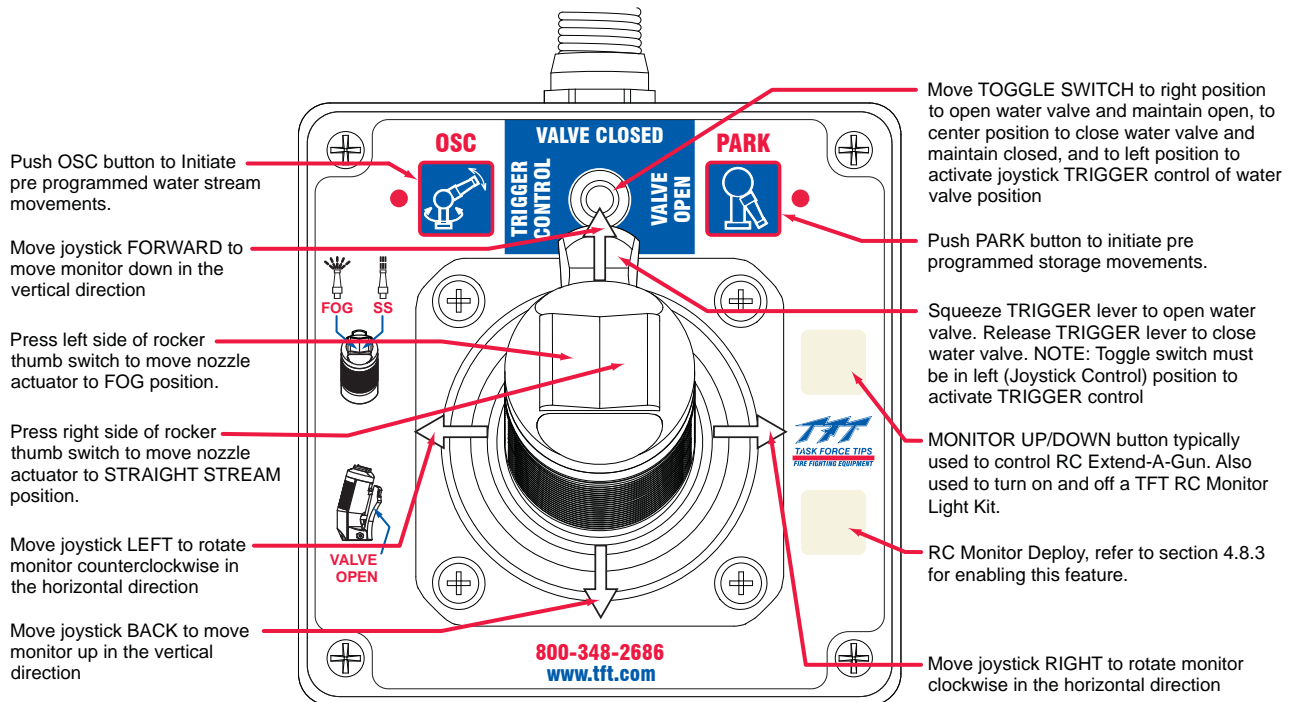

Fig. 4.8.2  
Joystick Label

### 4.8.2.1 PROPORTIONAL SPEED CONTROL

Joystick operator stations that have the proportional speed control feature enabled are able to vary the rotational (horizontal) and up/down (vertical) speed at which the monitor travels. The further the joystick is moved in any direction, the faster the monitor moves in that direction. See section 4.8.3 for board configuration.

### 4.8.2.2 MONITOR DEPLOY FEATURE

Joystick operator stations that have the deploy feature enabled will be able to move the RC monitor to a predetermined position with the press of a single button, refer to section 3.2.10. Button is located on lower right side of joystick. See section 4.8.3 for board configuration. Overlay labels are supplied with each monitor and can be applied to the buttons, refer to section 4.1.5.

### 4.8.2.3 RC EXTEND-A-GUN CONTROL

Joystick operator stations that have the RC Extend-A-Gun control enabled will be able to extend or retract the RC Extend-A-Gun with the press of a single button. Button is located on upper right side of joystick. See section 4.8.3 for board configuration. Overlay labels are supplied with each monitor and can be applied to the buttons, refer to section 4.1.5.

### 4.8.3 JOYSTICK BOARD CONFIGURATION

To change the configuration:

1. Ensure power is OFF to the unit.
2. Remove lid from enclosure.
3. Locate DIP switches on board and select configuration based on Figure 4.8.3.
4. Verify seal area is clean and undamaged. Verify that no wires are caught between lid and box. Replace lid.

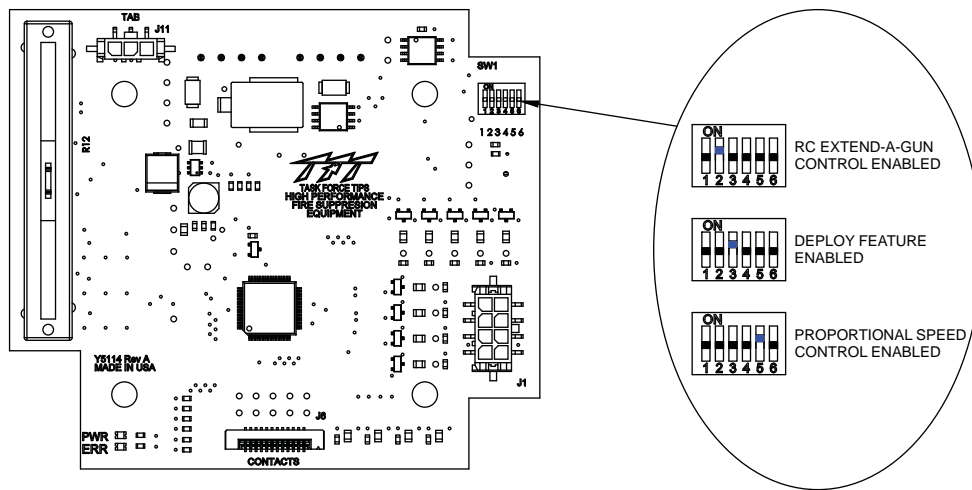

Figure 4.8.3  
Board Configuration

### 4.8.4 GATEABLE VALVE CONTROL

Valve gate control is combined between the sliding valve position control lever along with the toggle switch and joystick trigger. When the lever is at the bottom, the valve opens just enough to have a usable water stream. As the lever is moved towards the top the amount of water flow is increased. When the lever is all the way at the top, the valve is fully open. The valve position LEDs located around the valve position control lever indicate the actual position of the valve as received from the valve interface box.

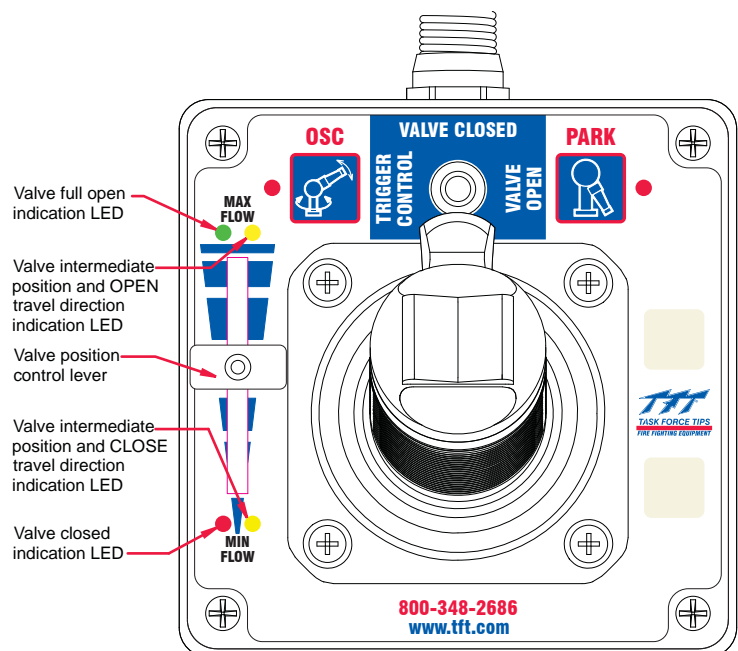
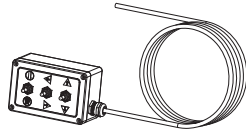

Figure 4.8.4

## 4.9 TOGGLE SWITCH MONITOR OPERATOR STATION (Y4E-TS)



This operator station allows the monitor to be controlled by three toggle switches. The installer will need to mount the operator station and connect the cable to the monitor and power.

### 4.9.1 ENCLOSURE MOUNTING

Select proper operator location. Enclosure is designed to be surface mounted and the size is 5" x 3 1/8" (127 x 80mm). Height to top of switches is 3 1/8" (80mm). Refer to Figure 4.9.1 for mounting hole dimensions.

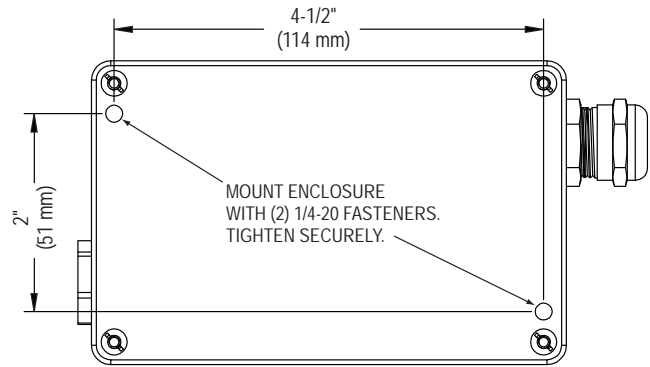

Figure 4.9.1  
Toggle Switch Operator Station Hole Dimensions

### 4.9.2 ELECTRICAL WIRING

See figure 4.0 for typical connections. The 4-conductor cable from the operator station needs to be connected to power (red & black) and to the communication link (blue & white) from the monitor. Refer to Figure 4.2.2 for typical cable preparation.

### 4.9.3 OPERATION

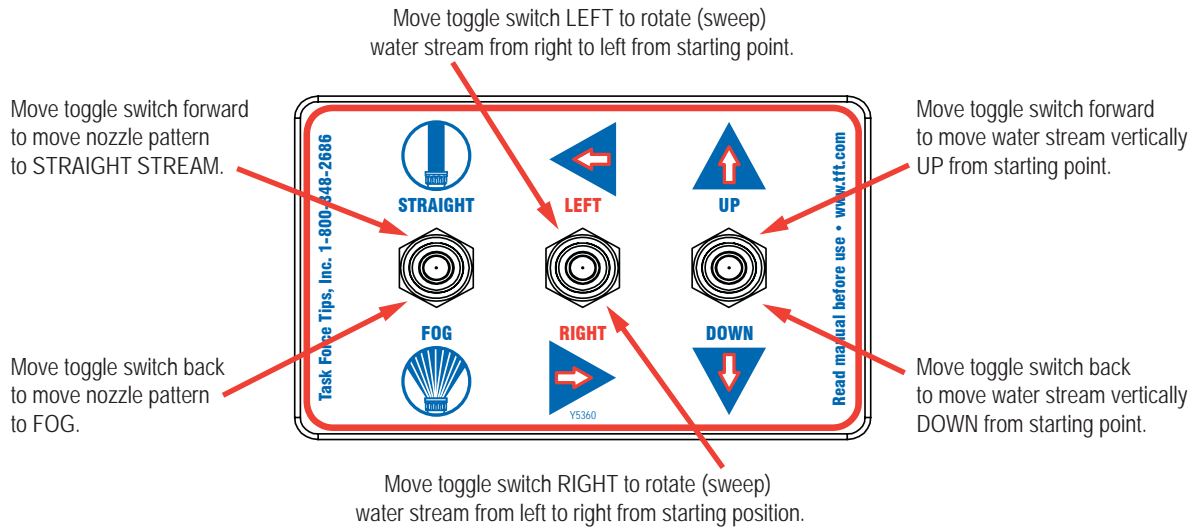
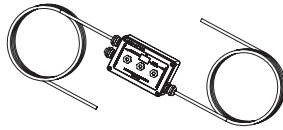

Fig. 4.9.3  
Operator Station Label

## 4.10 MONITOR COMMUNICATION INTERFACE CONTROL (Y4E-COMM)



This Communication Interface Control converts discrete input signals into serial communications for controlling the monitor. The discrete input signals can be from a joystick, toggle switches, relay contacts or Canbus output module. The interface box accepts +12/24 VDC signals, but can be field changed to accept ground signals. The installer will need to mount the interface box and connect the cable to the monitor and power.

### 4.10.1 ENCLOSURE MOUNTING

Select proper enclosure location. Enclosure is designed to be surface mounted and the size is 5" x 3 1/8" (127 x 80mm). Height of enclosure is 2 3/8" (60mm). Refer to Figure 4.9.1 for mounting hole dimensions.

### 4.10.2 ELECTRICAL WIRING

See figure 4.0 for typical connections. The 4-conductor cable from the communication interface box needs to be connected to power (red & black) and to the communication link (blue & white) from the monitor. Refer to Figure 4.2.2 for typical cable preparation.

See figure 4.10.2 for connecting INPUTS cable.

Function	Interface Box Cable Color
UP	WHITE
DOWN	BLUE
LEFT	YELLOW
RIGHT	BROWN
FOG	GREEN
STREAM	ORANGE
(-) BLACK	BLACK
(+) RED	RED

Figure 4.10.2  
Communication Interface Wire Color/Function

### 4.10.3 INPUTS SIGNAL CONFIGURATION

The Communication Interface Control is shipped from the factory configured to accept +12/24 volt DC input signals, but can be field changed to accept ground input signals. To change the configuration:

1. Ensure power is OFF to the unit.
2. Remove lid from enclosure.
3. Locate DIP switches on communication board.
4. Slide DIP switch #4 to the OFF position to select GROUND inputs or slide to the ON position to select VOLTAGE inputs.
5. Verify rubber seal is clean and undamaged. Verify that no wires are caught between lid and box. Replace lid.

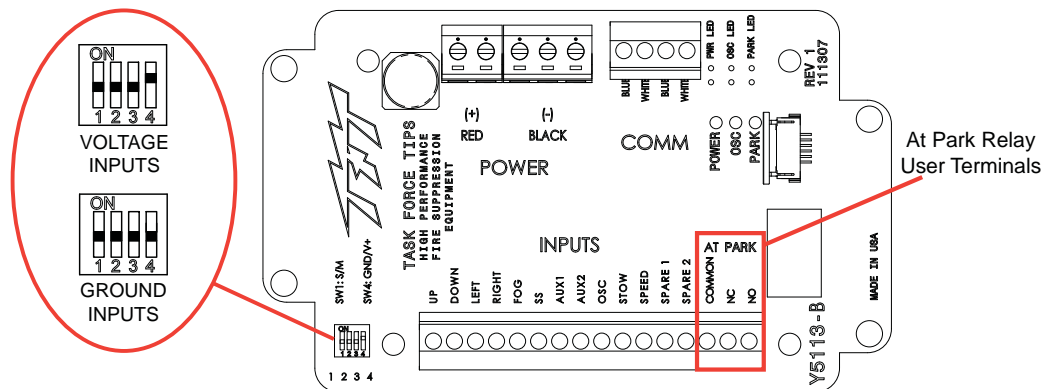

Fig 4.10.3  
Relay/Terminal Location

### 4.10.4 COMMUNICATION INTERFACE CONTROL WITH AT PARK RELAY (Y4E-COMM)

The Communication Interface Box provides feedback for the user that the monitor is in the AT PARK position. The Interface Box contains a circuit board that is equipped with a relay that is energized when the monitor is in use and de-energized when the monitor reaches its final PARK location. The contact rating of the relay is 1 amp @ 30VDC for resistive loads and 0.2 amps @ 30VDC for inductive loads.

The AT PARK relay has one Form-C contact (common, normally open, normally closed) that can be used. Figure 4.10.3 shows the terminal blocks available for user wiring.

## 4.11 MONITOR POSITION DISPLAY (Y4E-DISP)

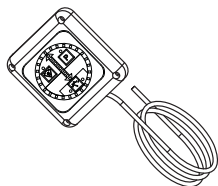

The monitor position display is supplied with a 10' (3 m) long 4-conductor cable. The installer will need to surface mount the enclosure in a dry area and connect the cable to power and the communication link of the monitor. Once the RC monitor and position display are installed and operational, the installer will need to program or teach the position display the full travel of the RC monitor.

### 4.11.1 ENCLOSURE MOUNTING

Select proper location for display.

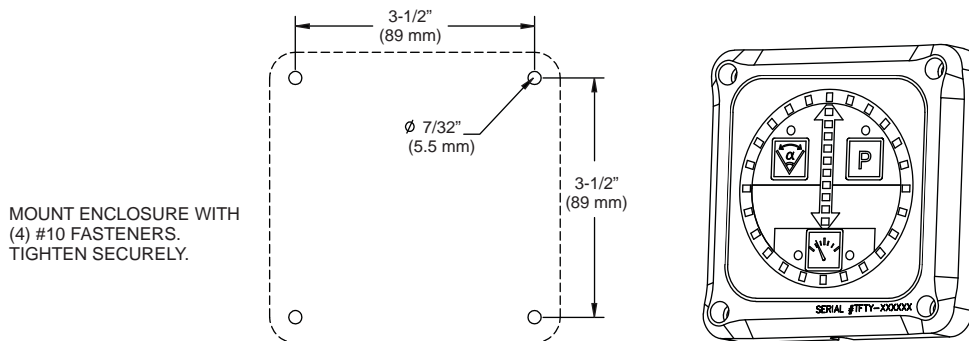

Fig 4.11.1  
Monitor Position Display Hole Dimensions

### 4.11.2 ELECTRICAL WIRING

See figure 4.0 for typical connections. The 4-conductor cable from the monitor position display needs to be connected to power (red & black) and to the communication link (blue & white) from the monitor. The cable exits the back side of the enclosure and can be installed straight back thru an opening in a panel or laid into groove in enclosure for flush mounting. Refer to Figure 4.2.2 for typical cable preparation.

### 4.11.3 PROGRAMMING DISPLAY

In order to correctly display the RC monitor position, **THE POSITION DISPLAY NEEDS TO BE TAUGHT THE FULL TRAVEL OF EACH AXIS.** The sequence is to program the "LEFT" stop, then "RIGHT" stop of the horizontal axis and next the "UP" stop and then "DOWN" stop for the vertical axis. Perform the following procedure to setup the position display.

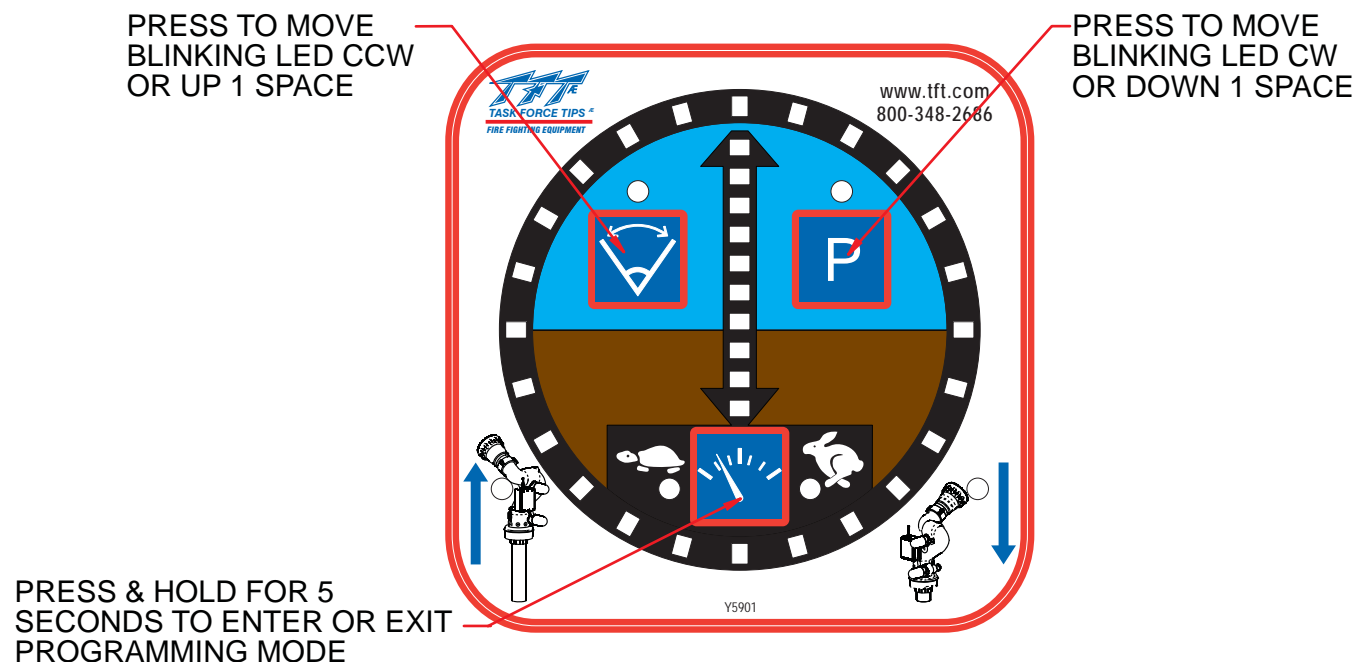

Fig 4.11.3

### **Enter Programming Mode**

- With power off, press and hold SPEED button on position display
- Apply power and continue to hold SPEED button until speed lights start to blink. One horizontal axis light will also be blinking.

### **Teach Left Stop**

- Operate RC monitor to the full left travel stop.
- Using the OSC (counter clockwise move) or PARK (clockwise move) buttons move the blinking light to appropriate location of horizontal travel.
- Always start by moving blinking light to the left.
- Press & hold OSC button for 5 seconds to store location. Horizontal axis light will change positions once location is stored.

### **Teach Right Stop**

- Operate RC monitor to the full right travel stop.
- Using the PARK (clockwise move) or OSC (counter clockwise move) buttons move the blinking light to the appropriate location of horizontal travel.
- Always start by moving blinking light to the right.
- Press & hold PARK button for 5 seconds to store location. Vertical axis light will start to blink once location is stored.

### **Teach Up Stop**

- Operate RC monitor to the full up travel stop.
- Using OSC & PARK buttons move blinking light to appropriate location of vertical travel.
- Press & hold OSC button for 5 seconds to store location. Vertical axis light will change positions once location is stored.

### **Teach Down Stop**

- Operate RC monitor to the full down travel stop.
- Using OSC & PARK buttons move blinking light to appropriate location of vertical travel.
- Press & hold PARK button for 5 seconds to store location. Display will start to blink all 4 stop locations once location is stored

### **Exit Programming Mode**

- Press & hold SPEED button for 5 seconds to exit programming mode. Speed lights will stop blinking.

## 4.12 REMOTE AUXILIARY INTERFACE CONTROL (YE-REMAUX)

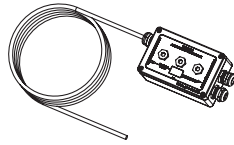

The Remote Auxiliary Interface Control allows a user to utilize the AUX1 and AUX2 buttons located on the monitor operator station or any remote operator station. The Interface Control is equipped with two relays that can operate lights, interface to a valve controller or in some cases operate a valve directly, etc. The contact rating of the relay is 16 amps @ 30VDC for resistive loads and 8 amps @ 30VDC for inductive loads.

The installer will need to mount the interface control and connect the cable to power and the communication link of the monitor.

**NOTICE** The Interface Control provides no overload protection for the device it is controlling. Failure to provide overload protection will damage relay contacts, which will disable device being controlled. Provide manual device operation, where necessary, in addition to remote control.

### 4.12.1 ENCLOSURE MOUNTING

Select proper enclosure location. Enclosure is designed to be surface mounted and the size is 5" x 3 1/8" (127 x 80mm). Height of enclosure is 2 3/8" (60mm). Refer to Figure 4.9.1 for mounting hole dimensions.

### 4.12.2 ELECTRICAL WIRING

See figure 4.0 for typical connections. The 4-conductor cable from the communication interface box needs to be connected to power (red & black) and to the communication link (blue & white) from the monitor. Refer to Figure 4.2.2 for typical cable preparation.

Each relay has one Form-C contact (common, normally open, normally closed) that can be used.

### 4.12.3 CONFIGURATION

The two relays on the circuit board can be individually configured as AUX1 or AUX2. Also the actuation of each relay can be configured to be momentary or latching. See Figure 4.12.3 for relay configuration DIP switch settings.

1. Ensure power is OFF to the unit.
2. Remove lid from interface box.
3. Locate DIP switches on board and select configuration.
4. Replace lid. Verify rubber seal is clean and undamaged. Verify that no wires are caught between lid and box.

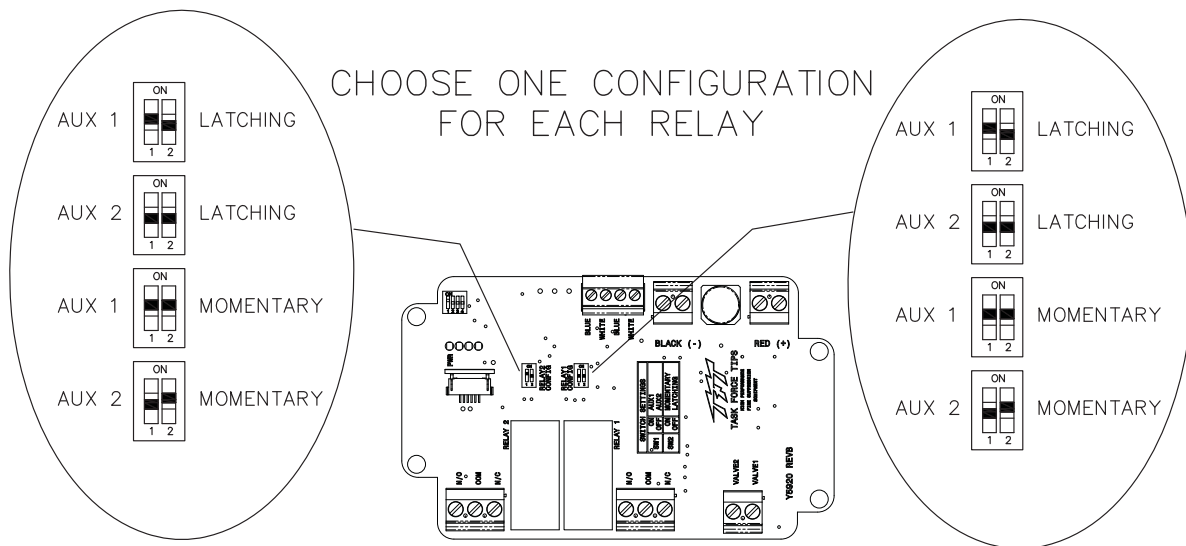
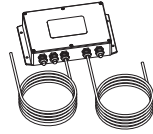

Figure 4.12.3  
Relay Configuration



### 4.13 ELECTRICAL RC MONITOR AERIAL TRUCK INSTALLATION



Two versions of the RC monitor have been designed for installation on aerial device trucks, the “-L” and “-P” versions. The “-L” version is supplied with one cable for connecting discrete inputs into the electronics enclosure, typically connections to a Canbus output module or toggle switches located at the turntable. The “-P” version is supplied with two cables for connecting discrete inputs, one cable typically for controls located in the basket and one cable for controls located at the turntable.

#### 4.13.1 ELECTRONICS ENCLOSURE MOUNTING

Select proper enclosure location. Enclosure is designed to be surface mounted and the size is 5 3/4” x 10” (146mm x 254mm). Height of enclosure is 2 1/4” (57mm). Refer to Figure 4.13.1 for mounting hole dimensions.

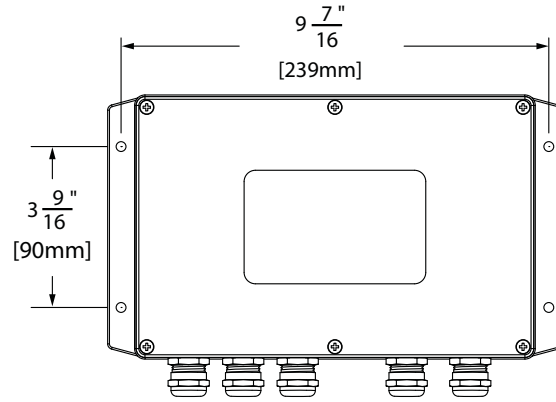

Fig 4.13.1  
Electrical Enclosure Mounting Hole Dimensions

#### 4.13.2 ELECTRICAL WIRING

On aerial devices, the installer will supply the required cables that run up the ladder or boom. Be sure to perform voltage drop calculations to verify that the supply voltage will remain at an acceptable level during monitor operation.

### 4.13.2.1 LADDER INSTALLATION ELECTRICAL WIRING (-L MODELS)

The electronics enclosure converts discrete input signals into serial communications for controlling the monitor. The discrete input signals can be from a joystick, toggle switches, relay contacts or Canbus output module. The electronic interface accepts +12/24 VDC signals, but can be field changed to accept ground signals.

The electronics enclosure is configured so that signals connected to the PRIMARY CONTROL cable will override any other operator stations (see section 4.0.1 and 4.0.2).

See Figure 4.13.2.1 for wiring connections.

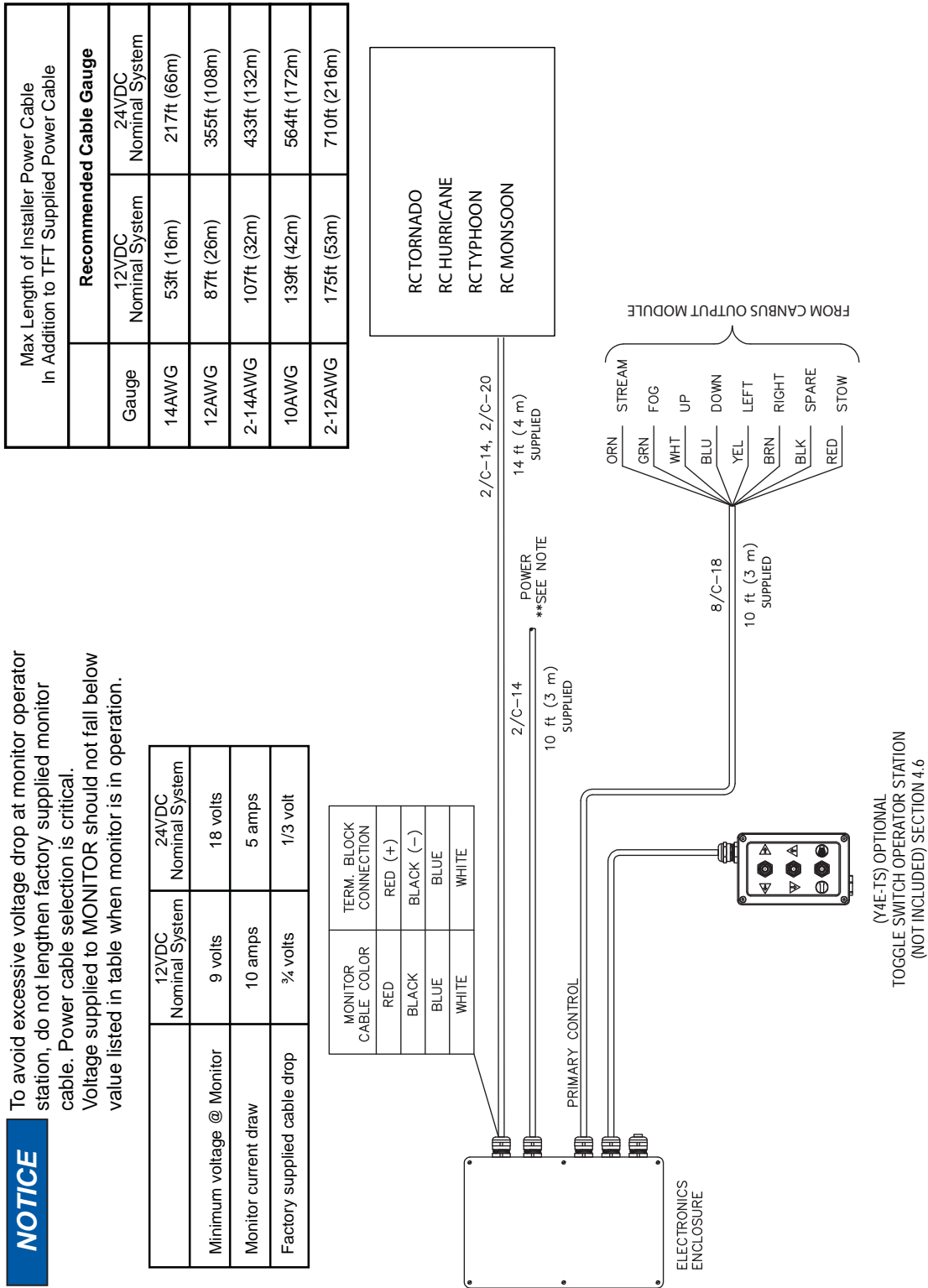

### 4.13.2.2 PLATFORM INSTALLATION ELECTRICAL WIRING (-P MODELS)

The electronics enclosure converts discrete input signals into serial communications for controlling the monitor. The discrete input signals can be from a joystick, toggle switches, relay contacts or Canbus output module. The electronic interface accepts +12/24 VDC signals, but can be field changed to accept ground signals.

The electronics enclosure is configured so that signals connected to the PRIMARY CONTROL cable will override any other operator stations (see section 4.0.1 and 4.0.2).

See Figure 4.13.2.2 for wiring connections.

**NOTICE**  
To avoid excessive voltage drop at monitor operator station, do not lengthen factory supplied monitor cable. Power cable selection is critical. Voltage supplied to MONITOR should not fall below value listed in table when monitor is in operation.

	12VDC Nominal System	24VDC Nominal System
Minimum voltage @ Monitor	9 volts	18 volts
Monitor current draw	10 amps	5 amps
Factory supplied cable drop	¾ volts	1/3 volt

MONITOR CABLE COLOR	TERM. BLOCK CONNECTION
RED	RED (+)
BLACK	BLACK (-)
BLUE	BLUE
WHITE	WHITE

Max Length of Installer Power Cable In Addition to TFT Supplied Power Cable	Recommended Cable Gauge	
	12VDC Nominal System	24VDC Nominal System
14AWG	53ft (16m)	217ft (66m)
12AWG	87ft (26m)	355ft (108m)
2-14AWG	107ft (32m)	433ft (132m)
10AWG	139ft (42m)	564ft (172m)
2-12AWG	175ft (53m)	710ft (216m)

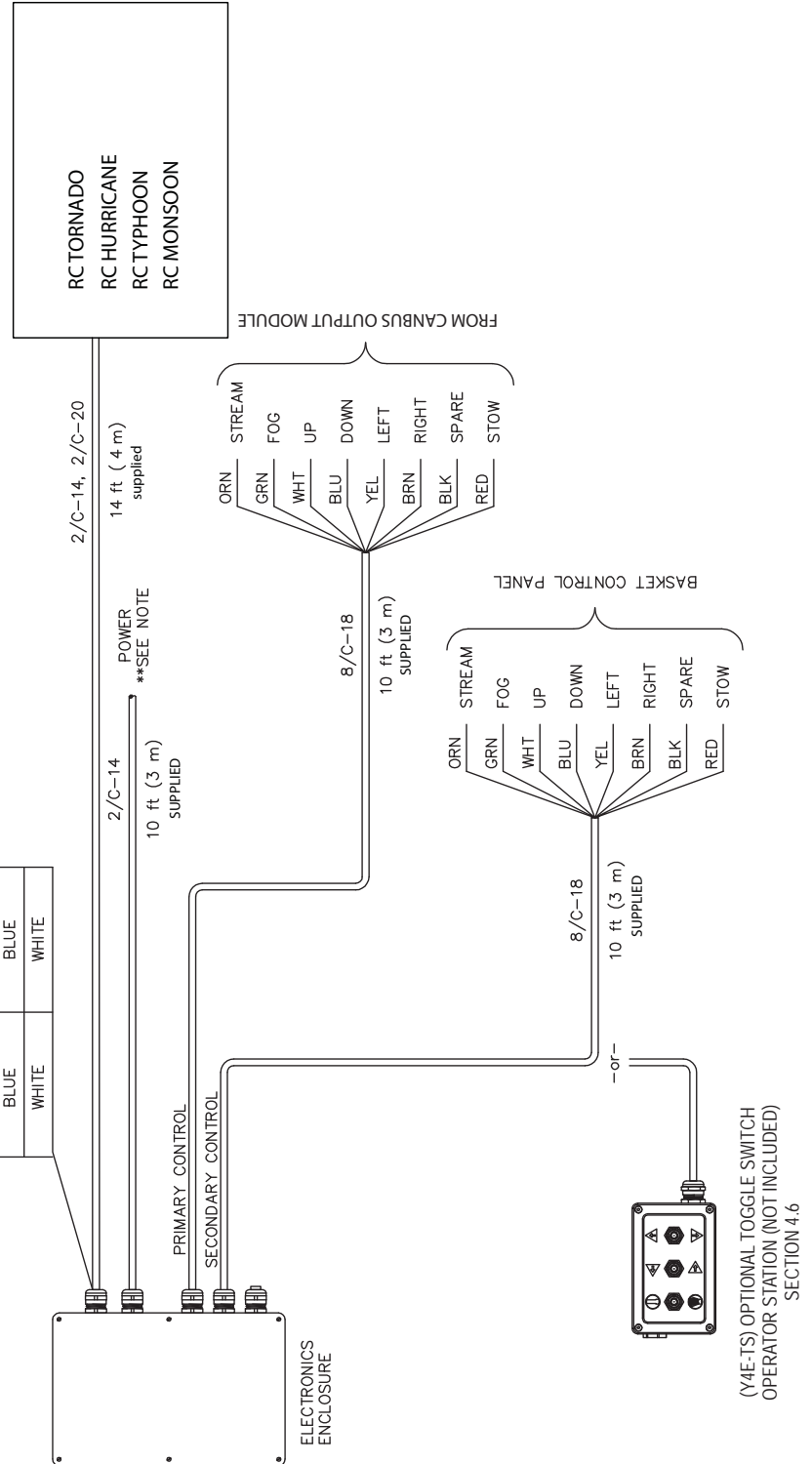

Figure 4.13.2.2  
Electrical Components (platform installations)

### 4.13.3 RECOMMENDED LADDER INSTALLATION CONFIGURATION

Various ladder & monitor installation configurations can lead to cab interference if the ladder is bedded with the monitor/nozzle not parked or if the monitor is moved while the ladder is in the bedded position. Also, vibration due to various road conditions can lead to unintended monitor/nozzle movement. This unintentional movement can lead to interference with the cab roof if adequate clearance is not provided between the cab and monitor. To mitigate this potential interference, TFT has designed the following features into the control system:

1. A user programmed PARK pattern with up to 10 points of movement to verify that monitor/nozzle is in a known, favorable position to avoid contact with other structures.
2. A Sit-N-Stay feature to correct monitor position if unintended movement due to road vibration occurs.
3. A monitor Inhibit signal to disable any operator station button commands or interface box movement commands when the monitor/nozzle is in a position where energizing the motors could damage the vehicle.

TFT recommends the following steps be taken to mitigate potential interference between the vehicle and monitor/nozzle package.

1. Monitor must be powered by Master On Switch to ensure monitor controls are active any time vehicle is in operation.
2. Integrate monitor AT PARK relay signal into logic to allow ladder bedding. See section 4.13.4
3. Activate INHIBIT INPUT signal when ladder is in the bedded position to disable any operator station button commands or interface box movement commands. See section 4.13.5

### 4.13.4 ELECTRICAL ENCLOSURE WITH AT PARK RELAY

The electronics enclosure provides feedback for the user that the monitor is in the AT PARK position. This electronics enclosure contains a circuit board that is equipped with a relay that is energized when the monitor is in use and de-energized when the monitor reaches its final PARK location. The contact rating of the relay is 1 amp @ 30VDC for resistive loads and 0.2 amps @ 30VDC for inductive loads.

The AT PARK relay has one Form-C contact (common, normally open, normally closed) that can be used. The figure below shows the terminal blocks available for user wiring.

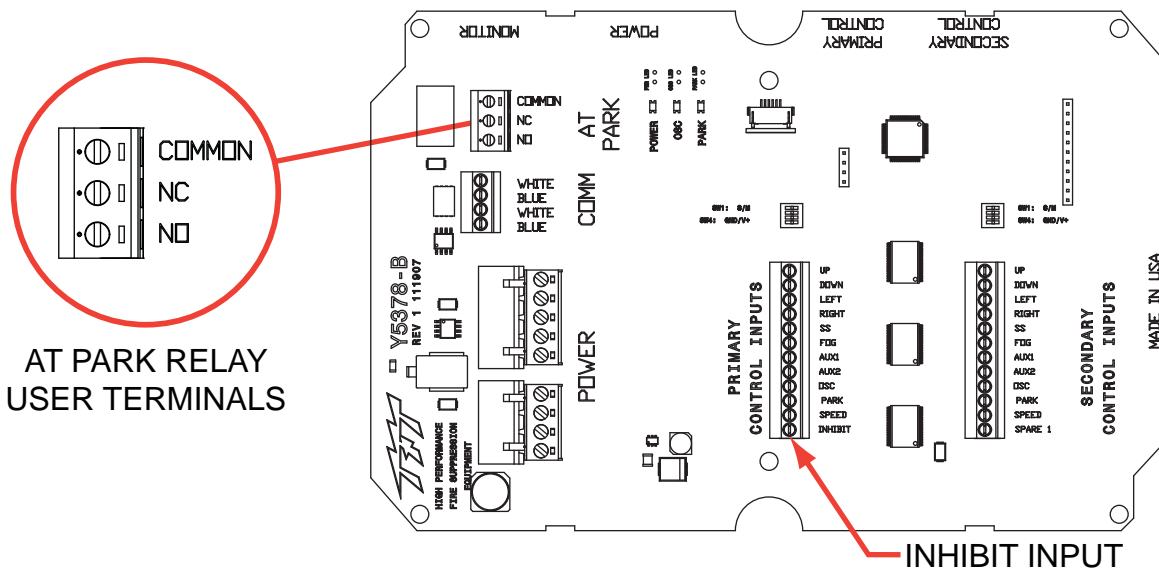

Figure 4.13.4  
Relay / Terminal Location

### 4.13.5 ELECTRICAL ENCLOSURE WITH INHIBIT INPUT

The electronics enclosure circuit board provides an input to INHIBIT any RC monitor movement. When active, this input will disable all movement commands to RC monitor. See figure 4.13.4 for input location. Requires a constant 12/24 vdc input signal in order to be active.

## 4.14 MULTIPLEX INTERFACE CONTROL (YE-CAN#)

This Multiplex Interface Control converts CANbus or multiplex communications into serial communications for controlling a TFT RC monitor or valve. This module is designed to work on a J1939 CANbus system and allows control of all TFT RC Monitors and RC Valve Under Monitor.

### Module Installation and Wiring

YE-CAN# module needs to be mounted onto circuit board located in electronics interface box.

- 1) Turn off power and remove lid from electronics interface box.
- 2) Position module and carefully plug into circuit board. Be careful to line up pins.
- 3) Connect CANbus wiring to module based on figure 4.14.
- 4) Replace lid onto box. Be sure to verify gasket is in place and that no wires are pinched between lid and box.
- 5) Tighten lid screws equally in a criss-cross pattern.

### Module Configuration

The YE-CAN# module can be configured based on the users requirements. Default configuration will have DIP switch #1 in the ON position with all others off (see CANbus structure document).

Up to four (4) YE-CAN# modules can be installed on the same CANbus communication system. If installing multiple YE-CAN# modules, DIP switches #5 & #6 need to be set accordingly (see CANbus structure document).

Contact TFT for the most up-to-date CANbus Structure document.

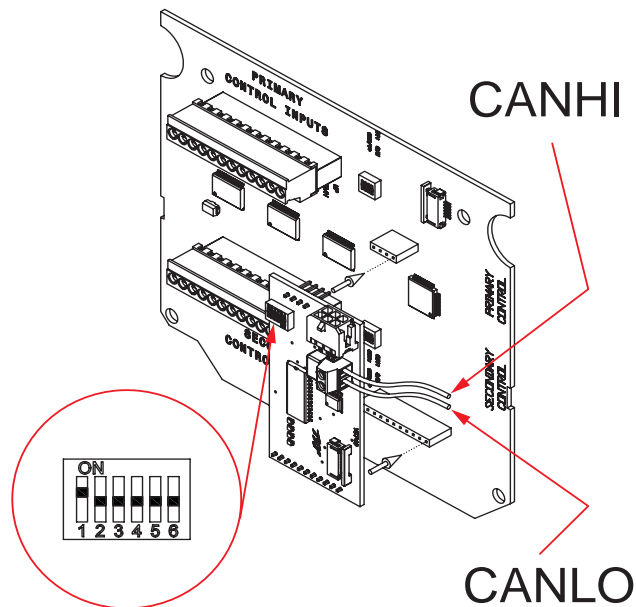
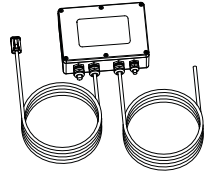

Figure 4.14

## 4.15 ETHERNET INTERFACE CONTROL (YE-ETHER)



The Ethernet interface control converts web based communications into serial communications for controlling a TFT RC monitor. The interface module acts as a web server and will allow a user to control multiple TFT RC monitors from a PC or web enabled device located in a central location using wired or wireless Ethernet. No special software is required to be installed on users PC. A standard web browser (Internet Explorer, Chrome, Firefox, Safari) is all that is needed. **Contact TFT for the most up-to-date web interface document.**

The YE-ETH-PLC interface version is designed to be used with an industrial type programmable logic controller (PLC). Current Ethernet interface has been tested with Allen-Bradley CompactLogix controllers and requires 3rd party TCP/IP module. **Contact TFT for the most up-to-date PLC interface Ethernet Structure document.**

### 4.15.1 INTERFACE ENCLOSURE MOUNTING

Select proper enclosure location. Enclosure is designed to be surface mounted and the size is 4 3/4" x 6 3/4" (120mm x 170mm). Height of enclosure is 2 1/4" (57mm).

Refer to Figure 4.15.1 for mounting hole dimensions.

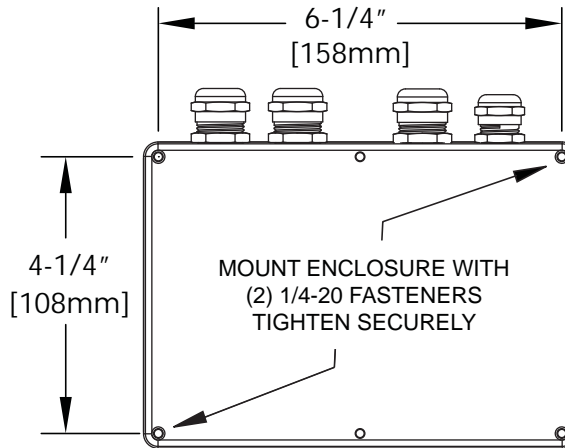

Figure 4.15.1

### 4.15.2 ELECTRICAL WIRING

See figure 4.0 for typical connections. Two cables are provided for connection to a TFT RC monitor and any remote TFT operator stations or controls. One 4-conductor cable is supplied with a 4-pin plug for connection to a TFT RC monitor. A second 4-conductor cable is supplied for connection to a protected power source (red & black) and to the communication link (blue & white) from any other TFT remote electrical control accessories. If no other remote control accessories exist, cut blue & white wires from free end of the second cable.

For wired Ethernet or PLC interface installations, the installer will need to remove rubber plug from one strain relief fitting and insert CAT5/CAT6 Ethernet cable, then make RJ45 connector connection inside enclosure. Acceptable cable diameter for larger strain relief fitting is 0.20" – 0.39" (5mm – 10mm) and for smaller strain relief fitting is 0.16" – 0.31" (4mm – 8mm).

### 4.15.3 DEFAULT NETWORK SETTINGS

IP Address:	169.254.1.1
Gateway:	169.254.1.1
Subnet Mask:	255.255.255.0
Host Name:	TFT_MONITOR

## 4.16 ELECTRIC NOZZLE ACTUATOR

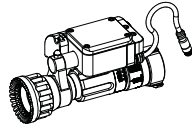

The electrical nozzle actuator is factory installed on the nozzle and requires only to be plugged into the mating monitor connector. For nozzles with electric pattern control, a cable with a female, waterproof connector is provided at the outlet of the TFT RC Monitor which attaches directly to several of TFT's electric nozzles. The cable used is a dual-key, micro type plug assembly. Any other nozzle should have the corresponding male electrical connector installed. Do not cut off the female connector on the monitor. This connector is molded onto the cable and must remain in place to maintain the water tightness of the electrical system. Moisture infiltration into nozzles with cut-off connectors will not be covered under warranty.

### 4.16.1 WIRING

The electric RC monitor is designed to control and is factory wired for a TFT electric actuated nozzle. Task Force Tips nozzles are available with a male cord plug. After mounting the appropriate nozzle onto the monitor, plug the male cord from the nozzle into the female cord located on the outlet of the monitor. Make sure the two coupling nuts are tightened securely to ensure a proper watertight seal.

If retrofitting an existing TFT nozzle, a male cord plug (TFT #Y5480) can be purchased and installed in place of the existing actuator cord. Please consult factory for installation.

### 4.16.2 OPERATION OF FLUSH, FOG, STREAM

#### **Nozzles without flush (All nozzles over 500 GPM)**

TFT Remote Controlled (RC) nozzles are equipped with a capability exclusive to TFT called "Smart Stream". Small movements of the outer stream shaper are needed to adjust fine fog while large movements are needed to see any change in straight stream. TFT accomplishes this by using a variable speed motor and sensors to tell the controls when the nozzle is in fog and when it is in straight stream.

"Smart Stream" automatically slows down the motor speed when the nozzle is operating in fog patterns. Slow changes in nozzle reaction can help maintain the stability of ladders and aerial platforms.

On the back of every nozzle pattern actuator is a small knob that rotates when the nozzle is changing pattern. This knob not only serves the purpose of indicating motor rotation it also is used for manual override in the event of power failure to the monitor. This small knob will change speed as the nozzle moves thru its various patterns. This is NORMAL! Observing this speed change is NOT an indication that the nozzle is binding or malfunctioning. If the end user desires to have this function disabled please call the factory and the correct procedure for accomplishing this change will be sent.

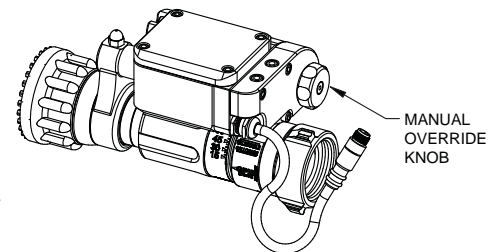

#### **Nozzles with flush (Some nozzles below 500 GPM and all nozzles below 250 GPM)**

TFT Remote Controlled (RC) nozzles are equipped with a capability exclusive to TFT called "Smart Stream". Small movements of the outer stream shaper are needed to adjust fine fog while large movements are needed to see any change in straight stream. TFT accomplishes this by using a variable speed motor and sensors to tell the controls when the nozzle is in fog and when it is in straight stream.

"Smart Stream" automatically slows down the motor speed when the nozzle is operating in fog patterns. Slow changes in nozzle reaction can help maintain the stability of ladders and aerial platforms.

On the back of every nozzle pattern actuator is a small knob that rotates when the nozzle is changing pattern. This knob not only serves the purpose of indicating motor rotation it also is used for manual override in the event of power failure to the monitor. This small knob will change speed as the nozzle moves thru its various patterns. This is NORMAL! Observing this speed change is NOT an indication that the nozzle is binding or malfunctioning. Smart stream serves an additional function when used with nozzles that have flush capability built into the movement of the stream shaper.

When nozzles of this type are used on bumper turrets in pump and roll operations it is very important that the operator of the unit not put the nozzle in flush accidentally. A slight over travel past full fog on competitive monitor nozzles will cause the nozzle to enter a partial or complete flush setting. When this occurs the flow of the nozzle can double or triple causing rapid exhaustion of the water supply carried on board the vehicle.

With "Smart Stream" technology the nozzle will automatically stop when it achieves the wide fog setting and the motor will cease turning. If the operator desires to flush the nozzle he must release the button and then press it again and the unit will travel into the flush position. Once understood this capability is extremely valuable for conserving tank water. If this feature is not desired by the end user please contact TFT service for instructions on how to disable this feature.

## 4.17 VALVE KITS

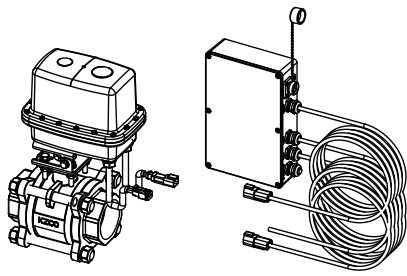

### 12VDC KITS / 24VDC KITS

YE-VKG-PD  
 YE-VK-PF  
 YE-VKG-PF  
 YE-VK-PH  
 YE-VKG-PH  
 YE-VK-PJ  
 YE-VK-PL

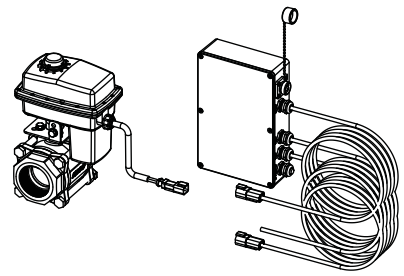

Each kit includes a water valve with plug-in electrical connection(s) and an interface control for “plug and play” wiring for power, water valve, monitor, joystick control and an extra operator station. The installer will need to mount the water valve and the interface box. The interface box is weatherproof and may be installed at any convenient location to route and connect all control system cables.

#### 4.17.1 VALVE MOUNTING

The water valve may be mounted at any location within the plumbing and at any orientation. The wiring and connector from the valve actuator should be protected from pulling and abrasion. The valve inlet and outlet connections and the valve/actuator dimensions are shown in the table below.

TFT Valve Kit #	TFT Valve #	"Inlet and Outlet Thread Connections"	Overall Dimensions inches (mm)		
			Face-to Face	Width	Height
YE-VKG-PD	Y7061	1" NPT	3.6 (91)	7.1 (180)	8.4 (213)
YE-VK-PF	Y7003	1 1/2" NPT	4.8 (122)	7.1 (180)	9.4 (239)
YE-VKG-PF	Y7062				
YE-VK-PH	Y7000	2" NPT	5.4 (137)	7.1 (180)	10.0 (254)
YE-VKG-PH	Y7063				
YE-VK-PJ	Y7001	2 1/2" NPT	6.7 (170)	8.6 (218)	13.7 (348)
YE-VK-PL	Y7002	3" NPT	7.4 (188)	8.9 (226)	14.3 (363)

#### 4.17.2 INTERFACE ENCLOSURE MOUNTING

The interface box should be mounted at a location to allow all factory-supplied cables to reach and connect. The enclosure is designed to be surface mounted and the size is 5 3/4" x 8 3/4" (146 x 222mm). Height of enclosure is 2 1/4" (57mm). Clearance is needed for the cables that extend from one side. Refer to Figure 4.13.1 for hole layout.

#### 4.17.3 ELECTRICAL WIRING

Each valve interface box is equipped with several connection points. A receptacle is built-in for connection to a joystick operator station. A 4-pin plug is available for connection to a TFT RC monitor, typically a RC Tornado. A 2-pin plug (standard valve kit) or a 6-pin plug (gateable valve kit) is available for control of a valve. These two cables should be routed to the appropriate device and plugged into the mating receptacle. The power cable should be routed to the truck's power distribution center and connected to a protected circuit. Refer to Figure 4.17.3 for typical connections.

The 2 1/2" and 3" valve actuators also require a separate connection to a protected circuit. These valves are shipped with an additional cable that includes a receptacle for connection to the valve actuator for power.



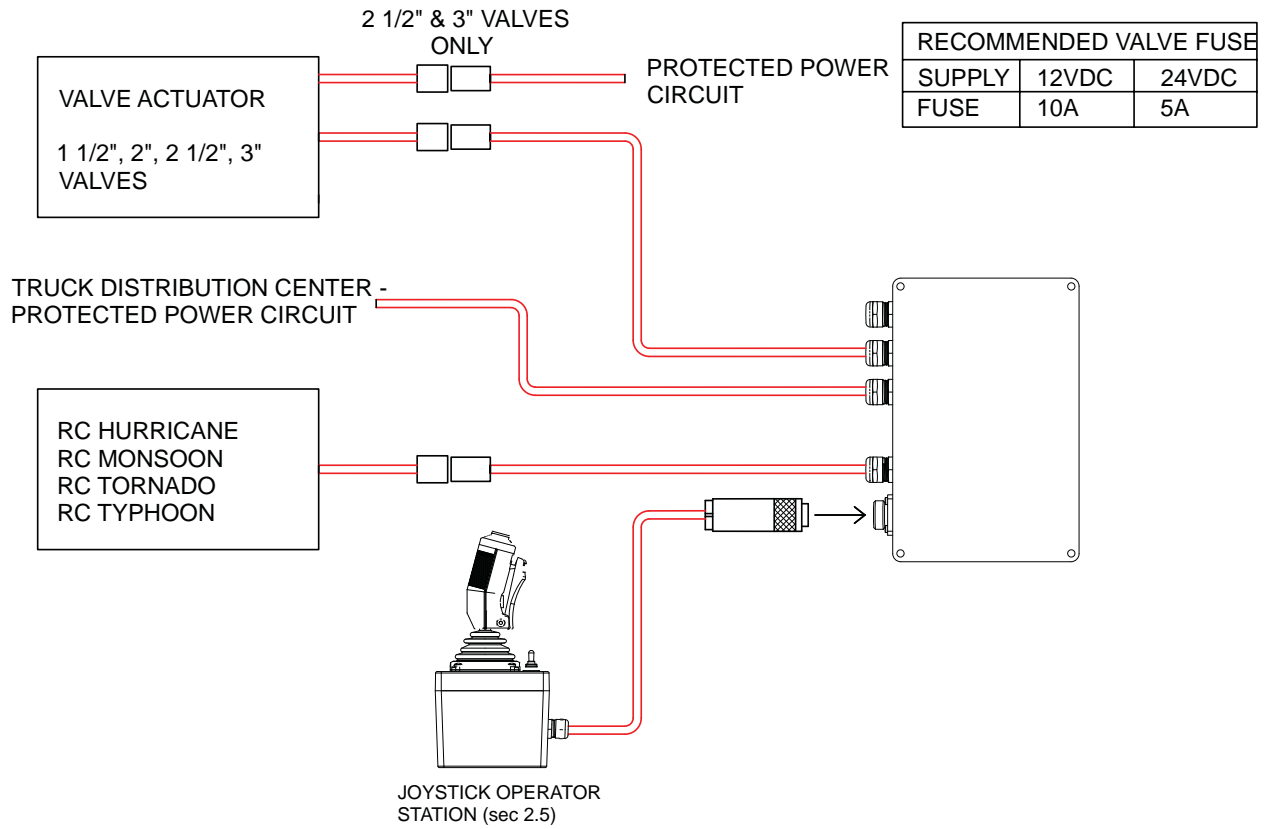

Figure 4.17.3  
VALVE ELECTRICAL COMPONENTS

#### 4.17.4 CONFIGURATION

The valve interface control is factory set for AUX2 and Momentary operation. This configuration is most suitable for joystick control of monitor and valve functions. If another operator station with keypad is used, it may be desired to change from momentary to latching operation so that the AUX2 key may be pressed and released once to open the water valve, then pressed and released again to close the valve.

**CONSULT FACTORY FOR INSTRUCTIONS TO CHANGE FROM MOMENTARY TO LATCHING OPERATION.**

## 5.0 TROUBLESHOOTING

For online service information updates, go to:

[www.tft.com/customerservice/FAQ.cfm](http://www.tft.com/customerservice/FAQ.cfm) Click on Remote Control Monitors.

### NOTICE

**FAILURE TO DISCONNECT POWER BEFORE REMOVING CIRCUIT BOARDS WILL RESULT IN DAMAGE AND VOID WARRANTY.**

SYMPTOM	POSSIBLE CAUSE	REMEDY
No Power LED	Polarity reversed	Check wiring and reverse polarity
Power LED On But No Operation	Low voltage due to: - wire gauge too small - wire length too long - poor connection - inadequate apparatus electrical system	Check connections and wiring per Remote Control (RC) Monitor Electrical Controls Supplemental Instructions. Verify voltage is above 9 volts.
	Monitor Disable Interlock turned on	Raise TFT RC Extend-A-Gun
Operation only from monitor operator station. PARK, & OSC LED's on remote station blink slowly when button pressed	Incorrect wiring	Check blue/white communication wiring
	Bad communication board	Replace communication board in monitor. If problem persists, replace communication board in remote operator station.
Monitor will not operate from any station and PARK & OSC LED's on monitor are on solid.	Bad communication board	Replace communication board in monitor.
During PARK pattern, monitor stops and PARK LED stays on solid.	Monitor has hit an obstruction before end of travel is reached.	Remove obstruction and run PARK pattern again.
	Manual override knob has been moved with power off.	Move monitor axis to each end stop making sure motor current limits. Run PARK pattern again.
Operation only from monitor control station	Communication board code version incompatible	Verify code versions on monitor and all operator stations
One Axis Fails To Operate From Any Control Station	Loose motor wiring connection	Check axis motor connection
	Bad motor control board	Interchange motor control boards and check if problem persists with same axis, If not, replace motor control board.
	Bad motor	Interchange motor control boards. Check if problem persists with same axis, If yes, replace motor.
	Bad membrane switch	Replace membrane switch / operator station
Vertical/Horizontal axis will not speed up	Loose encoder wiring connection	Check axis encoder connection
	Bad motor encoder	Interchange motor control boards. Check if problem persists with same axis. If yes, replace motor. Remove encoder cover and check for RED light just below disk. If no light, encoder is bad. Replace motor.
Vertical/Horizontal axis runs only in fast speed	Loose encoder wiring connection	Check axis encoder connection
	Bad motor encoder	Interchange motor control boards. Check if problem persists with same axis. If yes, replace motor. Remove encoder cover and check for RED light just below disk. If no light, encoder is bad. Replace motor.
Vertical/Horizontal axis only runs ~5 seconds and then stops.	Loose encoder wiring connection	Check axis encoder connection
	Bad motor encoder	Interchange motor control boards. Check if problem persists with same axis. If yes, replace motor. Remove encoder cover and check for RED light just below disk. If no light, encoder is bad. Replace motor.
PARK & OSC LED's on monitor control station blink rapidly when button pressed.	Loose encoder wiring connection	Check axis encoder connection
	Bad motor encoder	Interchange motor control boards. Check if problem persists with same axis. If yes, replace motor. Remove encoder cover and check for RED light just below disk. If no light, encoder is bad. Replace motor.

**5.0 TROUBLESHOOTING**  
(continued)

For online service information updates, go to:  
[www.tft.com/customerservice/FAQ.cfm](http://www.tft.com/customerservice/FAQ.cfm) Click on Remote Control Monitors.

SYMPTOM	POSSIBLE CAUSE	REMEDY
Unable to program PARK pattern.	Program enable timer expired.	Cycle power and enter PARK programming mode within 1 minute
Monitor will not operate from Y4E-COMM communication interface box or Ladder/Platform version electronics enclosure.	Incorrect wiring	Check blue & white communication wiring
	Incorrect INPUTS configuration	Verify DIP switch #4 setting matches system wiring (ON for voltage inputs, OFF for ground inputs).
Y4E-DISP Position Display has all vertical axis or horizontal axis light blinking	No communication with monitor	Check blue/white communication wiring.
	Improper or no programming of monitor stops	Re-teach stops per section 4.8.3
	Programmed travel does not match actual travel of monitor due to: <ul style="list-style-type: none"> <li>• Monitor axis has moved by manual override knobs</li> <li>• Monitor has hit obstruction</li> </ul>	Move monitor axis to each end stop making sure motor current limits.
Y4E-DISP Position Display has one vertical axis light or one horizontal axis light rapidly blinking.	No communication with monitor	Check blue/white communication wiring.

## 6.0 WARRANTY

Task Force Tips, Inc., 3701 Innovation Way, Valparaiso, Indiana 46383-9327 ("TFT") warrants to the original purchaser of its Remote Control Monitor Electronic Controls ("equipment"), and to anyone to whom it is transferred, that the equipment shall be free from defects in material and workmanship during the five (5) year period from the date of purchase.

TFT's obligation under this warranty is specifically limited to replacing or repairing the equipment (or its parts) which are shown by TFT's examination to be in a defective condition attributable to TFT. To qualify for this limited warranty, the claimant must return the equipment to TFT, at 3701 Innovation Way, Valparaiso, Indiana 46383-9327, within a reasonable time after discovery of the defect. TFT will examine the equipment. If TFT determines that there is a defect attributable to it, it will correct the problem within a reasonable time. If the equipment is covered by this limited warranty, TFT will assume the expenses of repair.

If any defect attributable to TFT under this limited warranty cannot be reasonably cured by repair or replacement, TFT may elect to refund the purchase price of the equipment, less reasonable depreciation, in complete discharge of its obligations under this limited warranty. If TFT makes this election, claimant shall return the equipment to TFT free and clear of any liens and encumbrances.

This is a limited warranty. The original purchaser of the equipment, any person to whom it is transferred, and any person who is an intended or unintended beneficiary of the equipment, shall not be entitled to recover from TFT any consequential or incidental damages for injury to person and/or property resulting from any defective equipment manufactured or assembled by TFT. It is agreed and understood that the price stated for the equipment is in part consideration for limiting TFT's liability. Some states do not allow the exclusion or limitation of incidental or consequential damages, so the above may not apply to you.

TFT shall have no obligation under this limited warranty if the equipment is, or has been, misused or neglected (including failure to provide reasonable maintenance) or if there have been accidents to the equipment or if it has been repaired or altered by someone else.

**THIS IS A LIMITED EXPRESS WARRANTY ONLY. TFT EXPRESSLY DISCLAIMS WITH RESPECT TO THE EQUIPMENT ALL IMPLIED WARRANTIES OF MERCHANTABILITY AND ALL IMPLIED WARRANTIES OF FITNESS FOR A PARTICULAR PURPOSE. THERE IS NO WARRANTY OF ANY NATURE MADE BY TFT BEYOND THAT STATED IN THE DOCUMENT.**

This limited warranty gives you specific legal rights, and you may also have other rights which vary from state to state.

Visit TFT's web site at [tft.com](http://tft.com)