



# MANUAL: TORNADO & TORNADO RC MONITOR

## INSTRUCTIONS FOR INSTALLATION, SAFE OPERATION AND MAINTENANCE

### **⚠ DANGER**

Read instruction manual before use. Operation of this device without understanding the manual and receiving proper training is a misuse of this equipment. A person who has not read and understood all operating and safety instructions is not qualified to operate the Tornado or Tornado RC Monitor.

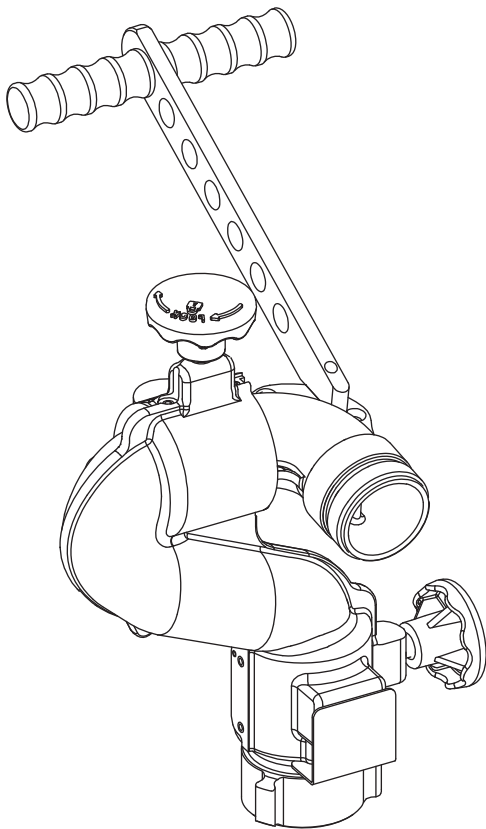

**TORNADO** 

Maximum Recommended Flow  
is 500 gpm (1900 l/min)  
Maximum Recommended Pressure  
is 200 psi (14 bar)

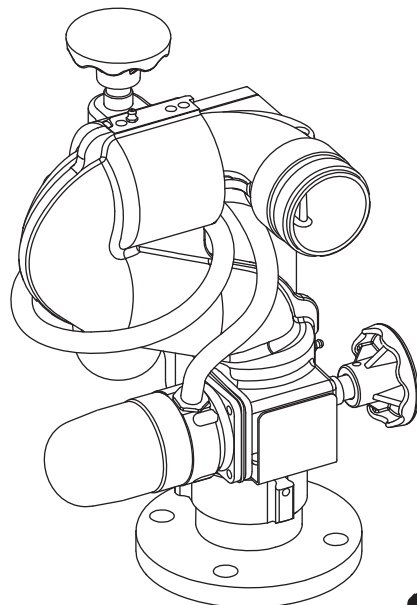

**TORNADO RC** 

**TASK FORCE TIPS, Inc.**  
MADE IN USA • [www.tft.com](http://www.tft.com)

2800 E Evans Ave, Valparaiso, IN 46383-6940 USA  
800-348-2686 • 219-462-6161 • Fax 219-464-7155

# Table of Contents

## 1.0 Meaning of Safety Signal Words

## 2.0 Safety

## 3.0 General Information

- 3.1 Mechanical and Electrical Specifications
- 3.2 Part Identification and Models
- 3.3 Inlets and Outlets
- 3.4 Overall Dimensions
- 3.5 Electrical Controls
  - 3.5.1 Motor Control Board (MCB) Auto Configure
  - 3.5.2 Motor Current Limiting
  - 3.5.3 Motor Soft Stops
  - 3.5.4 Motor Slow/Fast Speed
  - 3.5.5 Communication Protocol
  - 3.5.6 Oscillate and Stow Features

## 4.0 Installation

- 4.1 Structural Requirements for Monitor Mounting
- 4.2 Quick Connect Inlet Mounting and Travel Ranges
- 4.3 Nozzle Installation
- 4.4 Pressure Gage Port
- 4.5 Drain

## 5.0 Electrical Controls Installation

- 5.0.0 Standard Wiring Configuration
- 5.0.1 Alternative Wiring Configuration
- 5.1 Primary Monitor Operator Station
  - 5.1.1 Mounting
  - 5.1.2 Electrical Wiring
- 5.2 Optional Monitor Operator Stations
  - 5.2.1 Mounting
  - 5.2.2 Electrical Wiring
- 5.3 Tether Monitor Operator Station
  - 5.3.1 Holster Mounting
  - 5.3.2 Receptacle Mounting
  - 5.3.3 Electrical Wiring
- 5.4 Wireless Monitor Operator Station
  - 5.4.1 Mounting Receiver
  - 5.4.2 Electrical Wiring Receiver
  - 5.4.3 Mounting Charging Cradle
  - 5.4.4 Electrical Wiring Charging Cradle
- 5.5 Joystick Monitor Operator Station
  - 5.5.1 Mounting
  - 5.5.2 Electrical Wiring
    - 5.5.2.1 Wiring to a Communication Interface Box
    - 5.5.2.2 Wiring to a Primary Operator Station
- 5.6 Toggle Switch Monitor Operator Station
  - 5.6.1 Enclosure Mounting
  - 5.6.2 Electrical Wiring
- 5.7 Communication Interface Box
  - 5.7.1 Enclosure Mounting
  - 5.7.2 Electrical Wiring
  - 5.7.3 Input Signal Configuration
- 5.8 Monitor Position Display
  - 5.8.1 Enclosure Mounting
  - 5.8.2 Electrical Wiring
- 5.9 Connecting Monitor Cable Directly to Protected Power Supply
  - 5.9.1 Electrical Wiring
- 5.10 Electrical RC Monitor Aerial Truck Installation
  - 5.10.1 Electronics Enclosure Mounting
  - 5.10.2 Electrical Wiring
    - 5.10.2.1 Ladder Installation Electrical Wiring
    - 5.10.2.2 Platform Installation Electrical Wiring
- 5.11 Electric Nozzle Actuator Wiring

## 6.0 Operation

- 6.1 Manual Tiller Model

- 6.1.1 Horizontal Rotation and Rotation Lock
- 6.1.2 Elevation Control and Elevation Rotation Lock
- 6.1.3 Counter Balancing Nozzle, If Desired
- 6.2 Electrical Model
  - 6.2.1 Operator Stations
    - 6.2.1.1 Monitor Mounted Operator Station
    - 6.2.1.2 Primary Operator Station
    - 6.2.1.3 Optional Operator Station
    - 6.2.1.4 Tether Operator Station
    - 6.2.1.5 Wireless Operator Station
    - 6.2.1.6 Joystick Operator Station
    - 6.2.1.7 Toggle Switch Operator Station
  - 6.2.2 Master Override Feature
  - 6.2.3 Stow Feature
    - 6.2.3.1 Programming
    - 6.2.3.2 Stow Programming Example
  - 6.2.4 Oscillate Feature
    - 6.2.4.1 Programming
    - 6.2.4.2 Oscillate Program Retain Feature
  - 6.2.5 Operator Station Panels
  - 6.2.6 Override Knobs
- 6.3 Recommended Stowing Position
- 6.4 Flows and Pressures
  - 6.4.1 Stacked Tips Flow
  - 6.4.2 Tornado Monitor and Stream Straightener Friction Loss
- 6.5 Stream Straighteners
  - 6.5.1 Stream Straighteners with Stacked Tips
  - 6.5.2 Stream Straighteners with Fog Nozzles

## 7.0 Maintenance and Inspection

- 7.1 Lubrication
- 7.2 Performance Testing

## 8.0 Troubleshooting

## 9.0 Drawings and Parts List

## 10.0 Warranty

**⚠ DANGER**

### PERSONAL RESPONSIBILITY CODE

The member companies of FEMSA that provide emergency response equipment and services want responders to know and understand the following:



1. Firefighting and Emergency Response are inherently dangerous activities requiring proper training in their hazards and the use of extreme caution at all times.
2. It is your responsibility to read and understand any user's instructions, including purpose and limitations, provided with any piece of equipment you may be called upon to use.
3. It is your responsibility to know that you have been properly trained in Firefighting and /or Emergency Response and in the use, precautions, and care of any equipment you may be called upon to use.
4. It is your responsibility to be in proper physical condition and to maintain the personal skill level required to operate any equipment you may be called upon to use.
5. It is your responsibility to know that your equipment is in operable condition and has been maintained in accordance with the manufacturer's instructions.
6. Failure to follow these guidelines may result in death, burns or other severe injury.



Fire and Emergency Manufacturers and Services Association, Inc.  
P.O. Box 147, Lynnfield, MA 01940 • www.FEMSA.org





## 1.0 MEANING OF SAFETY SIGNAL WORDS

A safety related message is identified by a safety alert symbol and a signal word to indicate the level of risk involved with a particular hazard. Per ANSI standard Z535.4-1998, the definitions of the three signal words are as follows:

-  **DANGER** indicates an imminently hazardous situation which, if not avoided, will result in death or serious injury.
-  **WARNING** indicates a potentially hazardous situation which, if not avoided, could result in death or serious injury.
-  **CAUTION** indicates a potentially hazardous situation which, if not avoided, may result in minor or moderate injury.

## 2.0 SAFETY

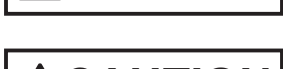
The operation of this monitor can be dangerous. The following must be observed at all times.

-  Injury can result from an inadequately supported monitor. The monitor mount must be capable of supporting 400 lbs (180 kg) of nozzle reaction force.
-  The stream exiting a monitor is very powerful and capable of causing injury and property damage. Make sure the monitor is securely attached to the base and pointing in a safe direction before water to the monitor is turned on. Use care in directing the stream.
-  The electric Tornado RC may be remotely operated. The electric drives are current limited but may still produce enough force to cause injury. Keep hands and fingers away from pinch points on the monitor.
-  Do not use the manual override knobs while the electric controls are in operation. The electric drives produce enough torque to cause injury.
-  Maximum flow and pressure is 500 gpm (1900 l/min) and 200 psi (14 bar). Damage or injury may result if the monitor is operated beyond these limits.
-  On many vehicle installations, the monitor is the highest point on the apparatus. Be sure there is sufficient clearance to safely pass under any doors or overhead obstructions. Always check stowed position of the monitor before moving.

## 3.0 GENERAL INFORMATION

The Tornado monitor is a 2-inch, 500 gpm maximum monitor. It is available in a manually operated model as well as an electric remote controlled model. The electric remote controlled model is known as the Tornado RC. Further specifications are shown in the following sections.

### 3.1 MECHANICAL AND ELECTRICAL SPECIFICATIONS

#### MECHANICAL SPECIFICATIONS

Weight	Manual	12 lbs	5.5 kg
	Electric	25 lbs	11.4 kg
Min. Flow Area	8.3 in <sup>2</sup>		24.5 cm <sup>2</sup>
Max Flow	500 gpm		1900 l/min
Max Operating Pressure	200 psi		14 bar
Elevation Travel Range	90° Above to 45° Below Horizontal		
Horizontal Travel Range	360° Continuous Manual 370° (185° left and right) Electric		
Standard Inlets	2.5"-7.5 NH Female 2.0"-11 BSP Female 2.5"-8 NPT Female 3.0"-8 NPT Female	2.5"-11 BSP Female 2.5" ANSI 150 Flange 2.0"-11.5 NPT Female TFT Code-RLF (fits Extend-A-Gun RC3)	
Standard Outlets	2.5"-7.5 NH Male 2.5"-11 BSP Male 1.5"-9 NH Male		
Materials Used	ANSI A356.0-T6 Aluminum, Stainless, Nylon		

## ELECTRICAL SPECIFICATIONS

Nominal operating voltage:	12 or 24 VDC (field changeable)	
Motor current:	Nominal*	Limit
Elevation motor:	6 amps	15 amps
Horizontal rotation motor:	6 amps	10 amps
Nozzle motor:	1 amp	5 amps
*with rated water pressure applied		
At rest current:	.25 amps	
Recommended fuse or circuit breaker size:	15 amps @ 12 volts, 7.5 amps @ 24 volts	
Operating temperature range:	-30F to +120F (-34C to +49C)	
Environmental Rating:	All components designed to meet minimum rating of NEMA 4 (IP65).	

## WIRELESS OPERATOR STATION

Charging Cradle:	
Nominal Operating Voltage	12 or 24 VDC
Operating Current	0.15 amps
Recommended Fuse or Circuit Breaker	2 amps
Transmitter Batteries	Use four (4) AA NiCad Batteries
Transmitter Power	5mW
Operating Frequency	2.4 GHz
Agency Approvals	FCC Part 15 - United States
	ISC - Canada
	CE - European Union

## 3.2 PART IDENTIFICATION AND MODELS

The Tornado and Tornado RC Monitor are shown in figs 3.2A and 3.2B along with the names of some various parts and controls.

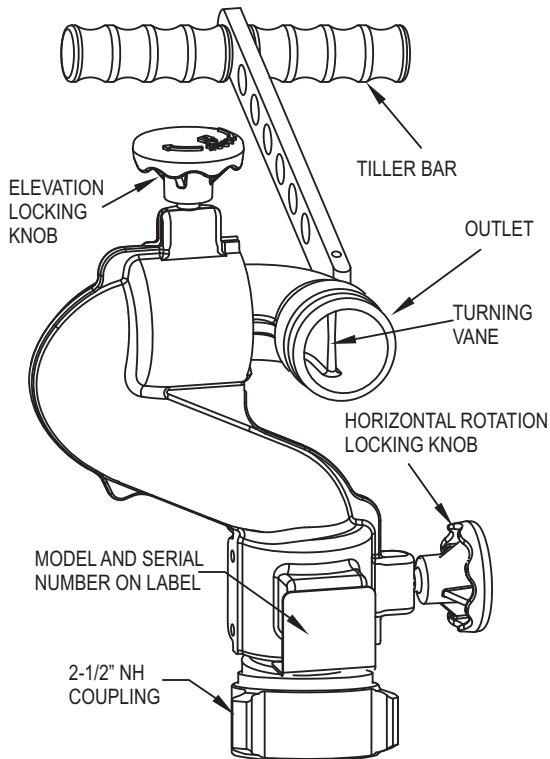

Fig. 3.2A Manual Tornado Monitor Part Identification

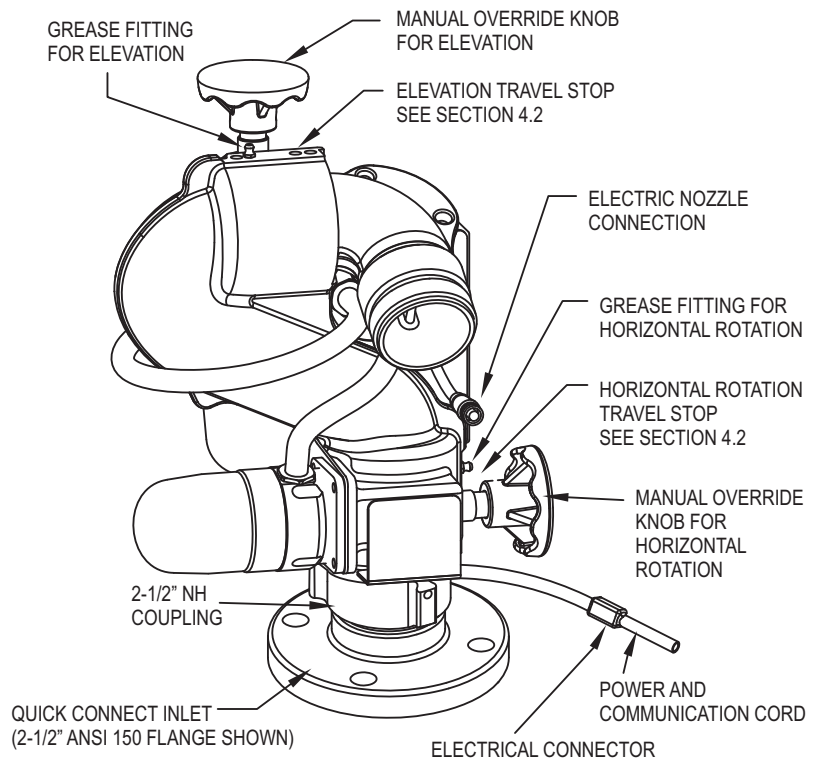

Fig. 3.2B Tornado RC Monitor Part Identification

### 3.3 INLETS AND OUTLETS

Available inlets and outlets are shown below and should be specified at time of order.

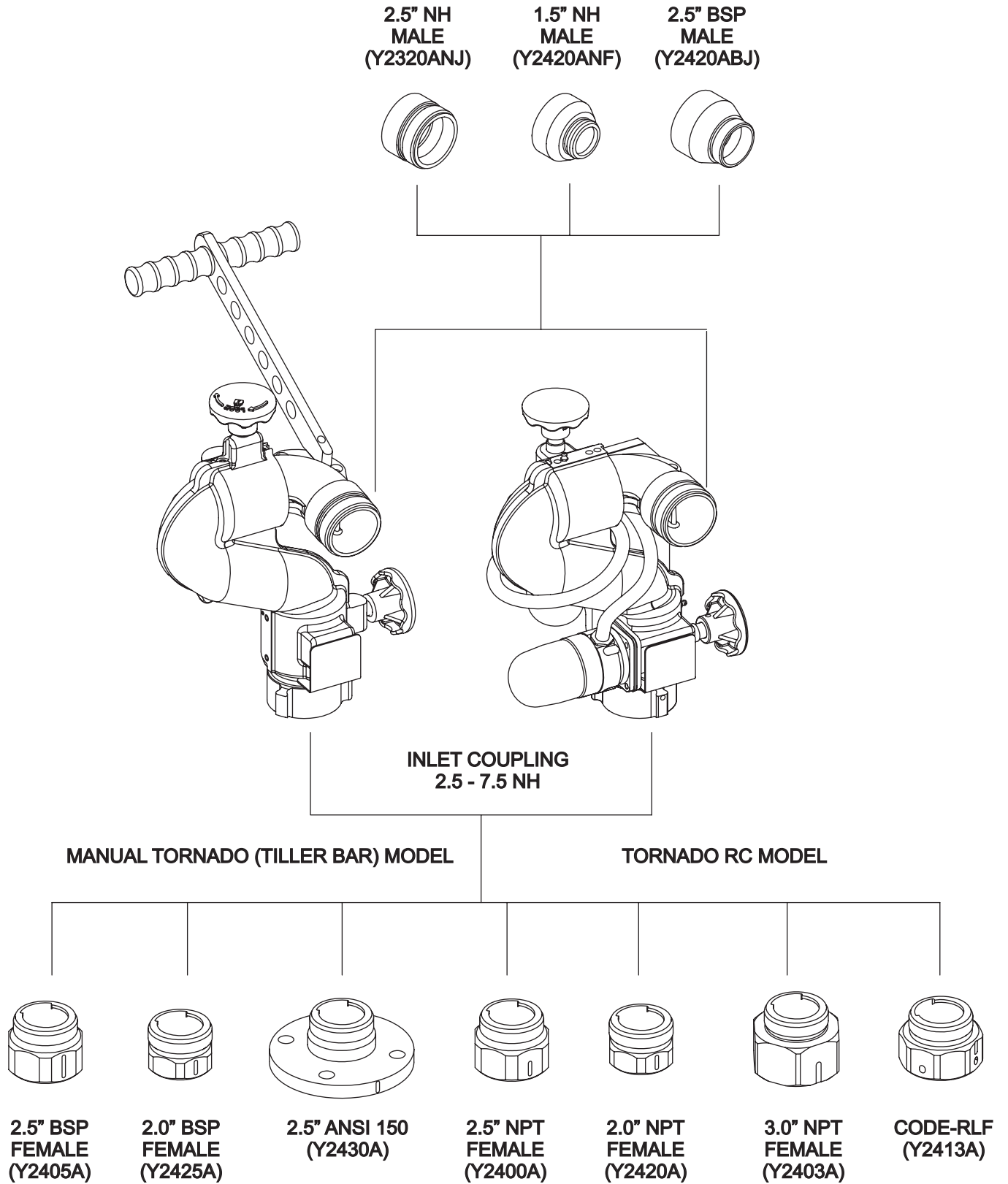
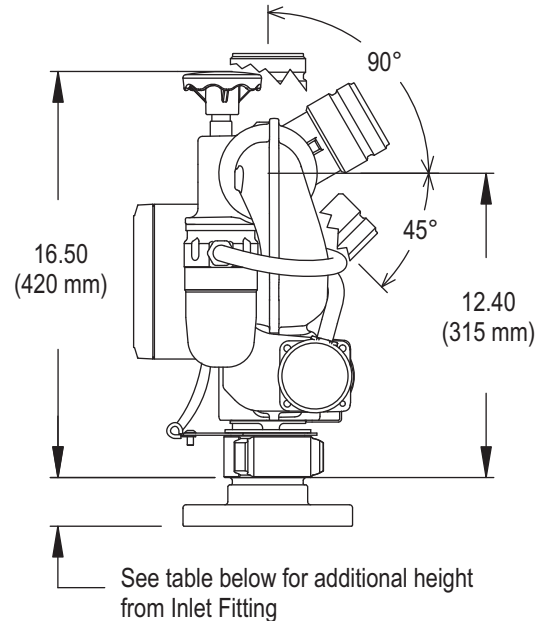
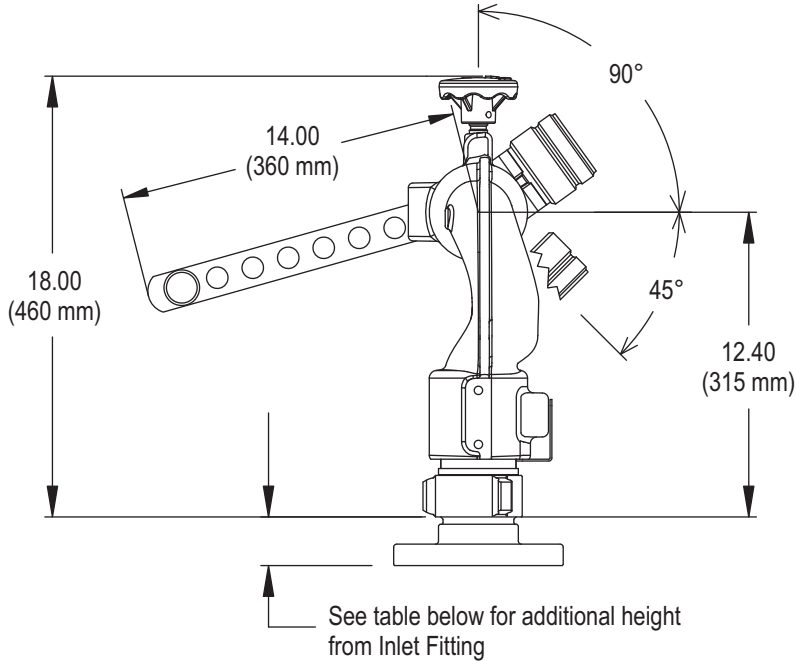
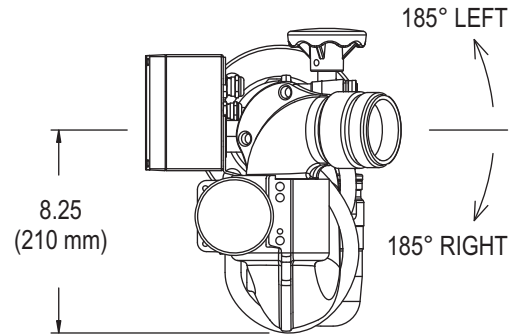
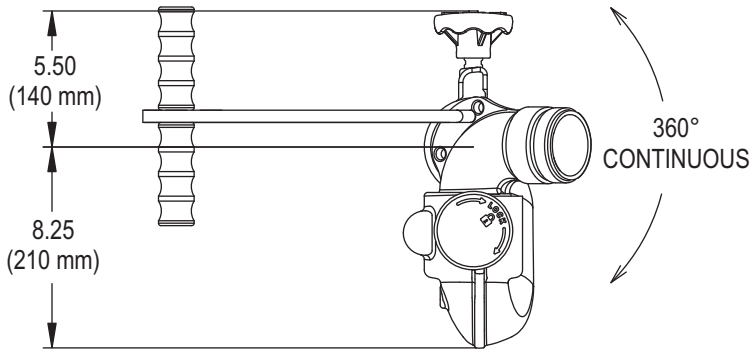

Fig 3.3  
Inlets and Outlets

### 3.4 OVERALL DIMENSIONS



Manual Tornado Monitor Dimensions  
Fig 3.4A

Electric Tornado RC Monitor Dimensions  
Fig 3.4B

MODEL	INLET FITTING TYPE	ADDITIONAL HEIGHT
Y2-*1*A	2-1/2" - 7.5 NH FEMALE (no inlet fitting)	0.00" 0 mm
Y2-*2*A	2-1/2" - 11 BSP FEMALE	2.00" 51 mm
Y2-*3*A	2.0" - 11.5 BSP FEMALE	1.50" 38 mm
Y2-*6*A	2.5" ANSI 150 FLANGE	2.00" 51 mm
Y2-*7*A	2-1/2" - 8 NPT FEMALE	2.00" 51 mm
Y2-*8*A	2.0" - 11.5 NPT FEMALE	1.50" 38 mm
Y2-*9*A	3.0 - 8 NPT FEMALE	2.44" 62 mm
Y2-*L*A	TFT CODE-RLF (fits Extend-A-Gun RC3)	2.00" 51 mm



### 3.5 ELECTRICAL CONTROLS

The electric Tornado RC monitor is controlled by a very powerful, state-of-the-art electronics system. The key components of the system are the motor control boards and a communication board. Each motor control board has its own microprocessor and a sophisticated motor control chip. The communication board also has a microprocessor, which handles the interface to the operator stations. All the components on these boards are solid state; there are no relays or electro-mechanical devices to wear out over time. The hardware and software have been designed with several key features:

#### 3.5.1 MOTOR CONTROL BOARD (MCB) AUTO CONFIGURE

Each monitor has three MCBs, one for each motor. The MCB controls motor movement and direction for horizontal rotation, elevation, and nozzle pattern. In the unlikely event of a MCB failure, the failed board can be removed and one of the other two remaining MCBs can be moved into that position. This MCB will then auto configure itself to take over the control of that axis, so that the monitor can continue to be used, with two of the three motors. This is also a helpful benefit when troubleshooting and requires fewer spare parts to be stocked.

#### 3.5.2 MOTOR CURRENT LIMITING

The microprocessor on the MCB continuously monitors the motor current. As the motor reaches an end stop or if there is an obstruction, the motor current rises very quickly and the motor control chip automatically shuts down the motor in a few milliseconds. This eliminates the need for any type of external limit switches and the associated wiring. The microprocessor also locks the operator from moving in the stopped direction again, until the operator first moves in the opposite direction.

#### 3.5.3 MOTOR SOFT STOPS

The horizontal and vertical motors are equipped with feedback encoders, which allow the microprocessor to know the motor position at all times. The first time a motor reaches an end stop or strikes an obstruction, the microprocessor sets a new soft stop position just before the end stop. From that point, on when the axis approaches the stop, the MCB automatically slows down the motor until the end stop is reached. This significantly reduces the wear on the motor, gearbox, and geardrives.

#### 3.5.4 MOTOR SLOW/FAST SPEED

When an operator presses one of the buttons, the associated motor starts in low speed mode for accurate control of the water stream. After approximately 1/2 second the motor automatically ramps up to high speed, for quickly moving into position. When quickly changing directions, monitor remains at speed of prior move. If low speed is selected, monitor does not ramp to high speed but remains in low speed.

#### 3.5.5 COMMUNICATION PROTOCOL

The communication from the monitor to the operator stations is performed over two wires using RS-485 serial protocol. Multiple operator stations can be added with only two wires for power and two wires for the RS-485 protocol between each station.

#### 3.5.6 OSCILLATE AND STOW FEATURES

The OSCILLATE feature allows the user to program up to 65 points of continuous movement of the horizontal and vertical axes. The OSCILLATE pattern can be programmed from any operator station that has the OSC button.

The STOW feature allows the user to move the monitor, with one touch of a button, to a safe position before moving the fire truck. The monitor will always move to two end stops to verify the correct position. During the programming procedure, the user has the ability to select which axis moves first. This is helpful to avoid lights, hoses, obstructions, etc. The user can program up to 10 points of movement to reach the final stow position. The STOW pattern can be programmed from any operator station that has the STOW button. A relay contact is available for connection to the truck alarm system.

### 4.0 INSTALLATION

#### 4.1 STRUCTURAL REQUIREMENTS FOR MONITOR MOUNTING

The structure that the Tornado Monitor is mounted to must withstand the internal pressure of the monitor, as well as shear and bending forces due to nozzle reaction. Nozzle reaction can be as high as 400 lbs (180 kg) (500 gpm at 200 psi).

For flanged connections, the use of flat flanges without raised faces is recommended. Use a full-face gasket as defined in SME 16.21 or ISO 7483. Tighten flange bolts in an alternating sequence as shown in figure 4.1. Tighten to 76-80 ft-lb (100-110 Newton-Meters).

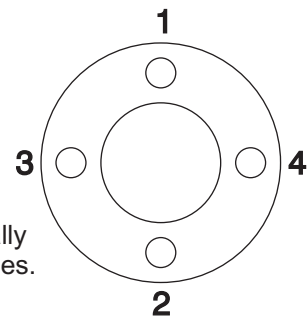

Tighten sequentially each bolt three times.

Fig 4.1 Flange Bolt Tightening Sequence



**WARNING** Injury can result from an inadequately supported monitor. The monitor mount must be capable of supporting the nozzle reaction force which can be as high as 400 lbs (180 kg). Flanges and pipe made from plastic are inadequate for monitor mounting and must not be used. This monitor is not recommended for portable use.

## 4.2 QUICK CONNECT INLET MOUNTING AND TRAVEL RANGES

Figure 3.3 shows the various Inlet Adapters used on the Tornado. These Inlet Adapters must be oriented upon installation so the Tornado will point in the desired direction. Figure 4.2A shows examples of Inlet Adaptors and the location of a "Straight Ahead Reference Mark". This figure also gives some information about securing the Tornado to the Inlet Adapter. Travel ranges relative to the Straight Ahead Reference Mark are shown in Figure 4.2B. Figure 4.2C gives the location of the "Stop Bolts", which are used to limit the travel.

**IMPORTANT:** Install so Straight Ahead Reference Mark is facing the desired direction.

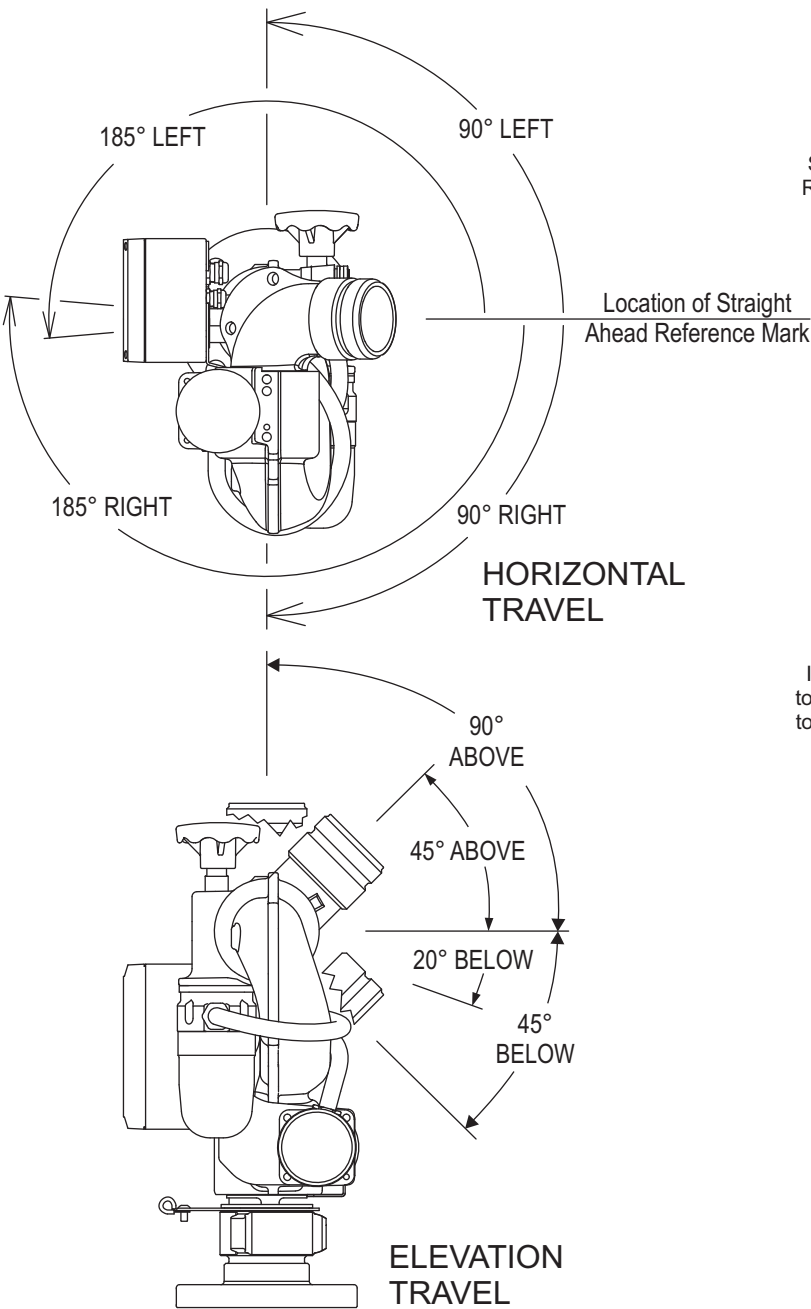

**Fig 4.2B Travel Ranges Relative to Straight Ahead Reference Mark**

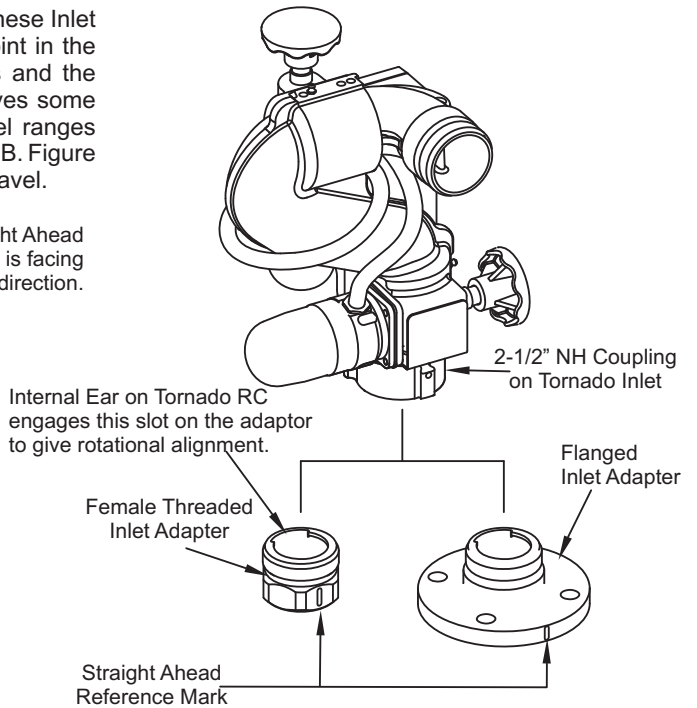

**Fig 4.2A Inlet Adapter and Straight Ahead Reference Mark**

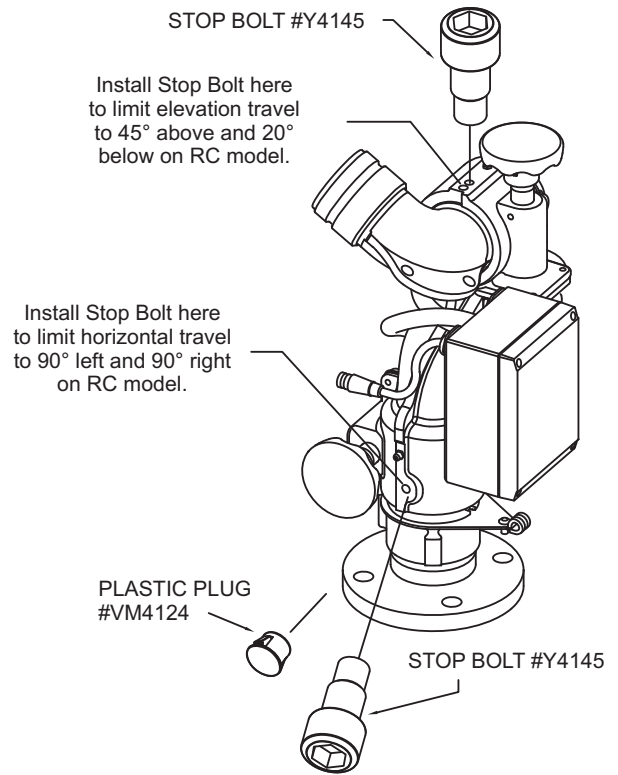

Pry out plastic plug and install Stop Bolt to obtain desired travel limits.

RC model with no stop bolts installed has 185° left and right travel limits.

Tiller model has continuous 360° horizontal rotation. Stop Bolts are not used on Tiller model.

**Fig 4.2C Stop Bolt Use**



### 4.3 NOZZLE INSTALLATION

The nozzle is simply screwed onto the monitor's exit threads.

For nozzles with electric pattern control, a cable with a female, waterproof connector is provided at the outlet of the Tornado RC which attaches directly to several of TFT's electric nozzles. The cable used is a dual-key, micro type plug assembly. Any other nozzle should have the corresponding male electrical connector installed. The waterproof cap should be installed when using stacked tips. Do not cut off the female connector on the monitor. This connector is molded onto the cable and must remain in place to maintain the water tightness of the electrical system.



**The nozzle threads must match the threads of the Tornado monitor in both size and type. Mismatched or damaged threads may cause the nozzle to leak or uncouple under pressure and could cause injury.**



**Do not connect aluminum to brass or brass to aluminum. Dissimilar metals coupled together can cause galvanic corrosion that will freeze the threaded joint or cause complete loss of thread engagement. If dissimilar metals must be coupled together, the effects of corrosion can be greatly delayed by various coatings on the metal such as powder paint, hard anodizing, or silicone grease.**

### 4.4 PRESSURE GAGE PORT

There is a raised boss on the back of the monitor. This raised boss is not machined from the factory but may be drilled and tapped for 1/4 NPT threads if a pressure gage is desired on the monitor.

### 4.5 DRAIN

There is no drain on the Torando Monitor itself. A drain valve should be installed on the monitor's inlet piping.

### 5.0 ELECTRICAL CONTROLS INSTALLATION

The electric RC monitor is supplied with a monitor mounted electronics box. The wiring on the monitor and for this electronics box is factory installed. The assembly is supplied with a 12-foot (3.7 m) length of cable for connection to the operator control stations as shown in Figure 5.0.0 and 5.0.1. This cable has 4-conductors which supply power and the communications from the operator stations to the monitor. To complete the installation, the installer will need to mount and wire the selected operator station boxes. The power supply for the monitor will need to be connected to a protected circuit from the truck's power distribution center. Refer to the specifications section for nominal current draw.

- Good mechanical connections on the wires are absolutely necessary and should be checked periodically. Poor electrical connections can cause power loss to the Tornado RC and be a fire hazard.
- Careful selection of wiring is critical to avoid excessive voltage drop.
- Be careful to route cables in a protected area away from high heat sources.
- Use grommets whenever wires pass through holes to prevent damage due to snags, abrasions, etc.
- Secure cables close to control box with plastic wire ties or cable clamps to relieve stress on the cables.
- Disconnect power before installing or servicing the electrical components. The RC monitor control boxes and motors are not rated as ignition proof, explosion proof, or intrinsically safe.



**The electric motors and other components are ignition sources. The electric drives should be operated only in areas where there is adequate ventilation and no hazard of flammable vapor buildup.**

#### Recommended Tool List

11/32" nut driver	20mm open-end box wrench	#2 Phillips screwdriver
Wire cutter/stripper	17mm open-end box wrench	Small flat blade screwdriver
Terminal crimping tool	5/32" drill bit	
Utility knife	25/32" drill bit	

## 5.0.0 STANDARD WIRING CONFIGURATION

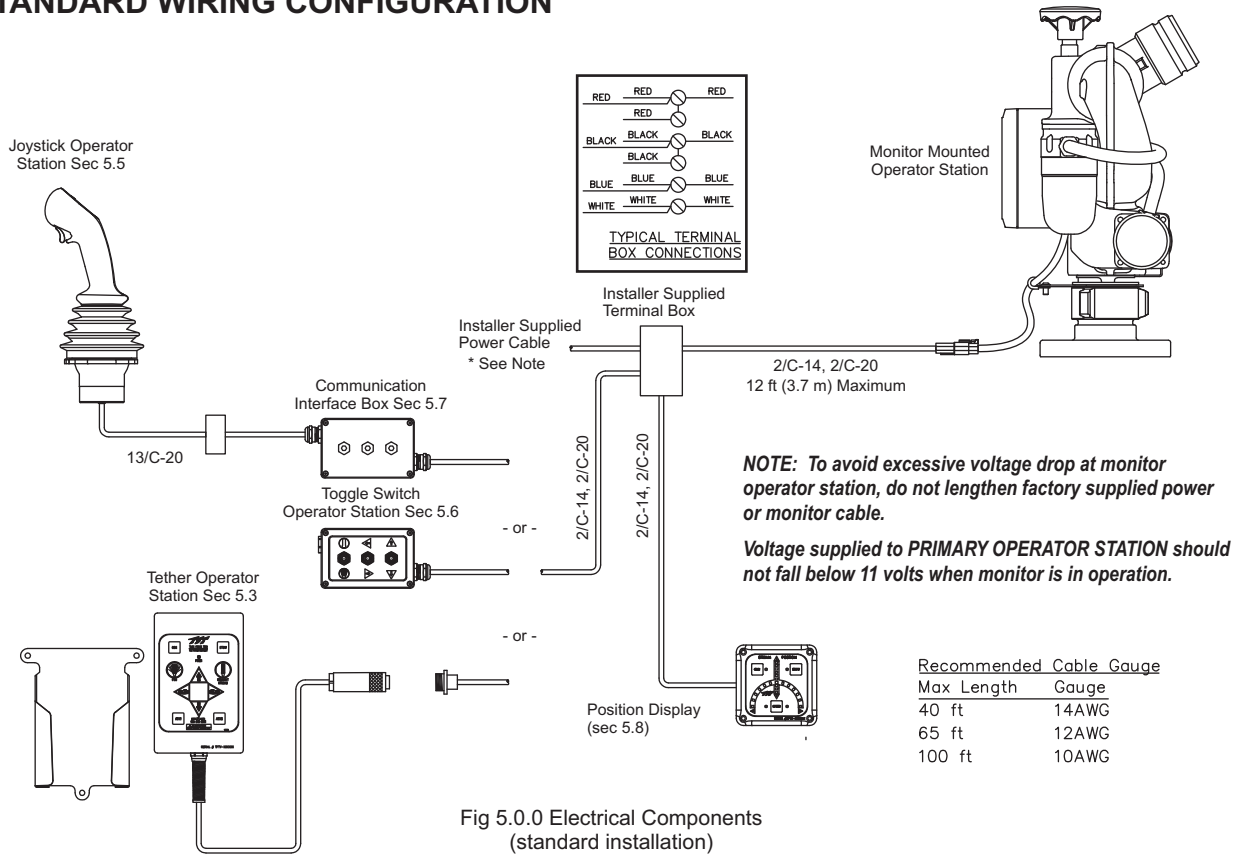

## 5.0.1 ALTERNATIVE WIRING CONFIGURATION

The electric RC monitor can also be configured with any of the TFT operator stations in figure 5.0.1.

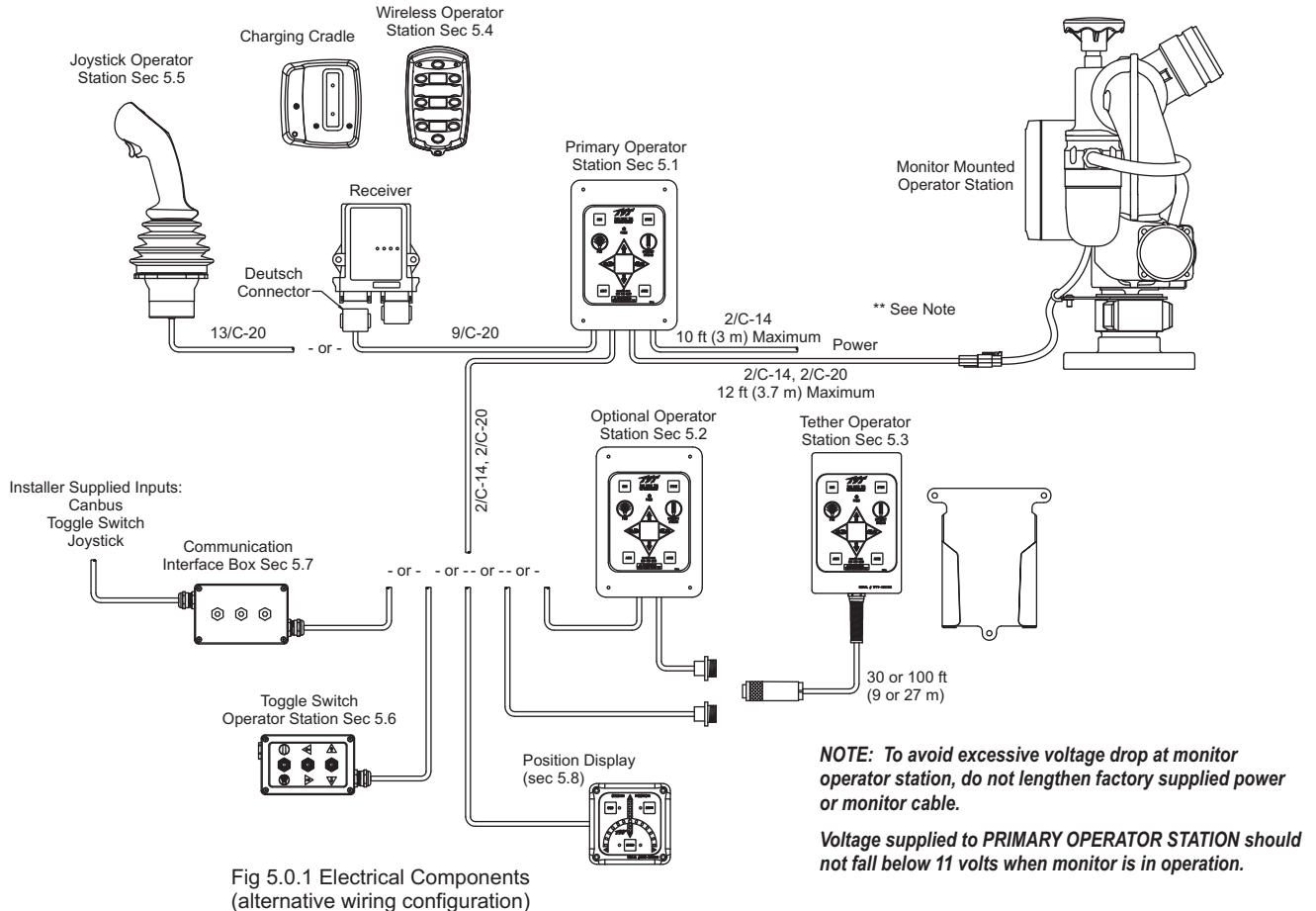

## 5.1 PRIMARY MONITOR OPERATOR STATION

This operator station will include the wiring connections for the cable from the monitor and the incoming power. In many installations this operator station will also include the wiring connections for the wireless, joystick, or tether operator station. The enclosure is designed to be recess mounted in a panel.

### 5.1.1 MOUNTING

Select proper operator location. Panel space required will be 5-1/8" x 7-7/16" (142 x 200mm). A depth of 3 1/2" (89mm) will be required behind the panel. Additional space will be required where the cables exit the back of the enclosure. Refer to Figure 5.1.1 for cutout dimensions.

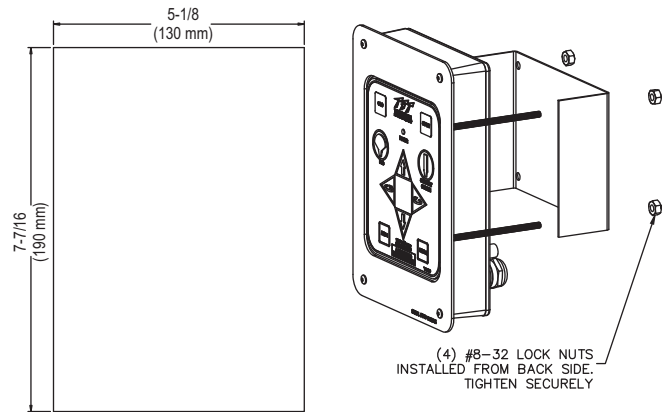

Fig 5.1.1  
Primary & Optional Operator Stations Cutout Dimensions

### 5.1.2 ELECTRICAL WIRING

After selecting and mounting the desired operator stations, refer to Figures 5.1.2B-E for wiring connections. Refer to Figure 5.1.2A for typical cable preparation. Be sure to tighten all terminal block screws securely.

Receiver Cable Wire Color	Termination Point In Operator Station
RED	RED (+)
BLACK	BLACK (-)
GREEN/BLACK	UP
WHITE/BLACK	DOWN
WHITE	LEFT
ORANGE/BLACK	RIGHT
BLUE	FOG
ORANGE	STRAIGHT STREAM
GREEN	NOT USED (CUT)

Fig 5.1.2  
Wireless Operator Station  
Wiring Color Code

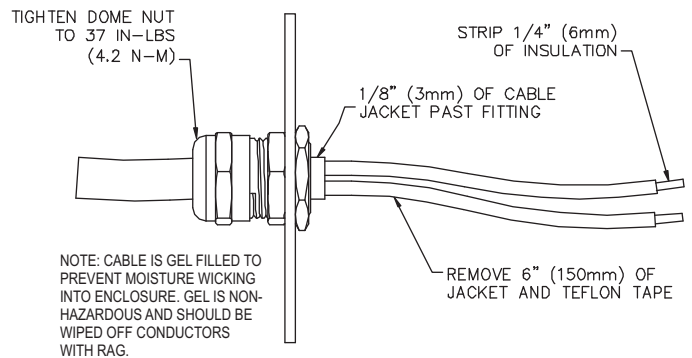

Fig 5.1.2A  
Typical Cable Preparation

#### FROM/TO MONITOR OR OPERATOR STATION

Refer to Figure 5.1.2B for connections.

#### FROM/TO TETHER OR OPT. OPERATOR STATION

Remove rubber plug in hole labeled WIRELESS OPER. STATION and discard. Refer to Figure 5.1.2C for connections.

#### WIRELESS OPERATOR STATION

Plug end of cable with Deutsch connector into gray receptacle on receiver. Make sure connector snaps into place.

Remove rubber plug in hole labeled WIRELESS OPER. STATION and discard.

Refer to Figure 5.1.2D for connections. Refer to Figure 5.1.2 for wire color designations.

#### MAIN POWER CONNECTION TO TRUCK

Route cable and connect to a protected circuit from the truck's power distribution center. Connect the red wire to positive and the black wire to negative (ground). Refer to Figure 5.1.2E for connections.

### IMPORTANT!!

When mechanical installation and electrical connections are complete, perform the following test to verify voltage supply is adequate and the current limiting feature is functioning.

- 1) Apply power to monitor control box.
- 2) Press LEFT or RIGHT button and hold until monitor reaches its stop position. Continue to hold button down.
- 3) Once movement is stopped, manually turn override knob in opposite direction while continuing to hold button down. If knob can be turned, then voltage supply is adequate. If knob cannot be turned and motor continues to operate, then the voltage supply or wiring is not adequate. Check connections and voltage connection point, rewire if necessary. **NOTE: Override knob will only turn in one direction.**

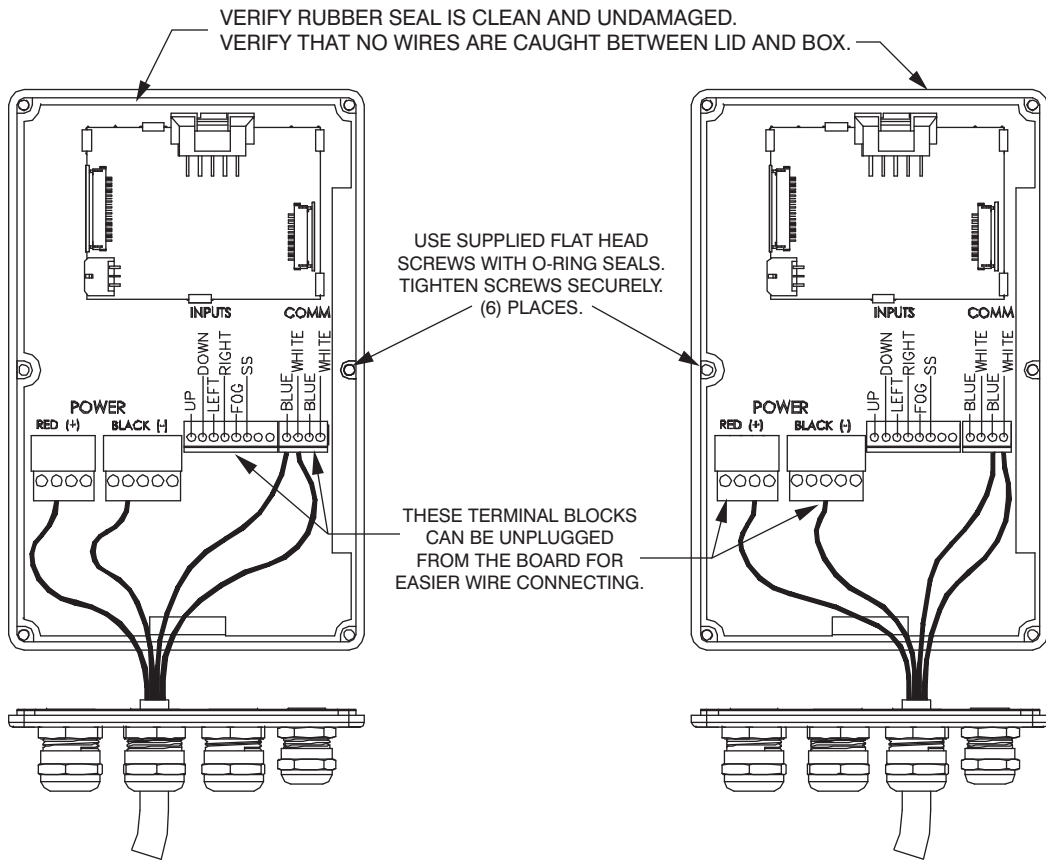

Fig 5.1.2B

From/To Monitor Or Operator Station Connections

Fig 5.1.2C

From/To Tether, Optional Operator Station, Toggle Switch Operation Station, or Communication Interface Box

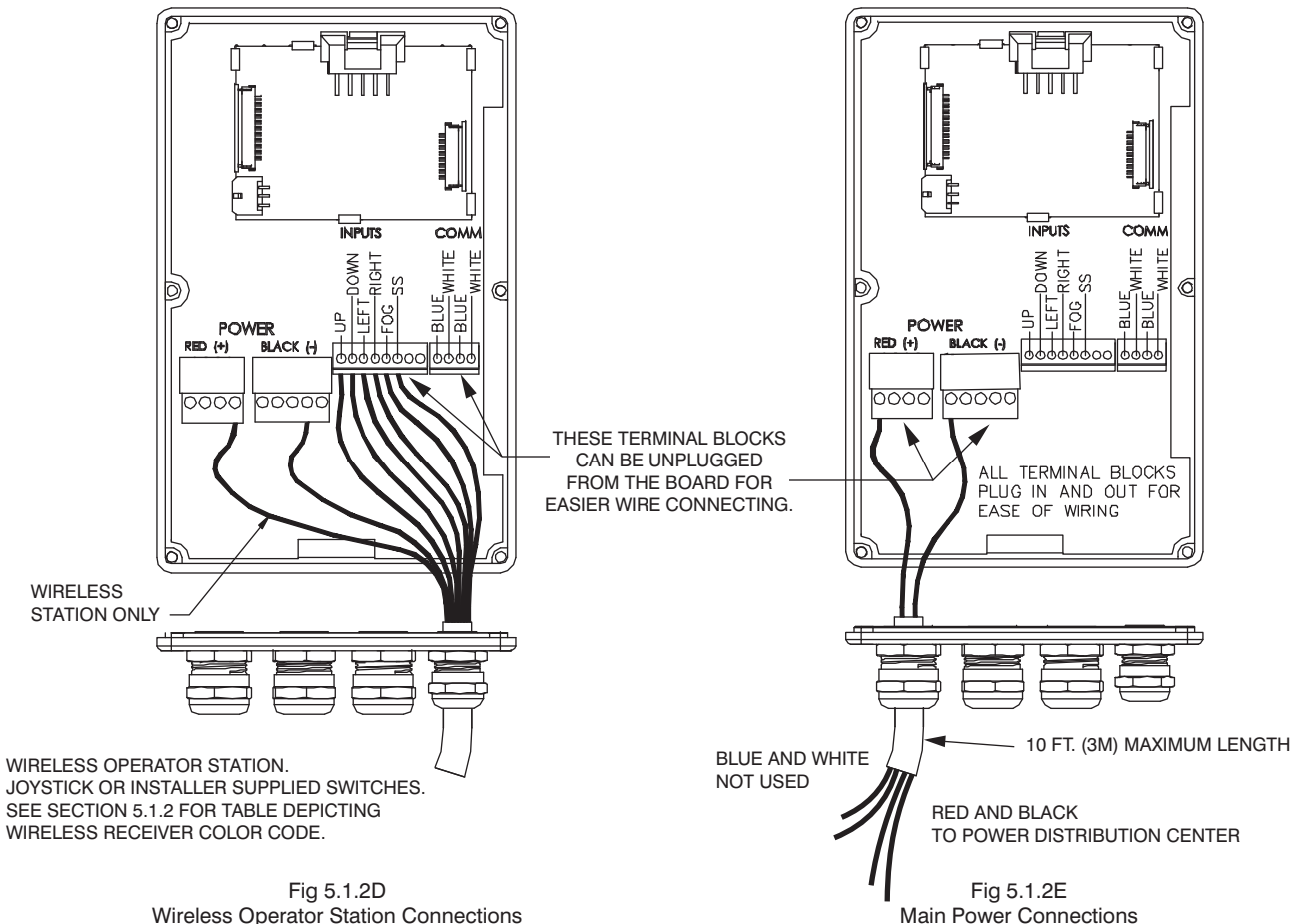

Fig 5.1.2D

Wireless Operator Station Connections

Fig 5.1.2E

Main Power Connections

## 5.2 OPTIONAL MONITOR OPERATOR STATIONS

The electronic package for the Tornado RC is designed for multiple operator stations. The operator stations use a RS-485 communication design and the communication boards in each station are connected in series. This gives the flexibility to choose more than one location on a truck to operate the monitor. To install multiple operator stations, complete the following instructions in this section and repeat for each additional station. The enclosure is designed to be recess mounted in a panel.

### 5.2.1 MOUNTING

See section 5.1.1

### 5.2.2 ELECTRICAL WIRING

See section 5.1.2

## 5.3 TETHER MONITOR OPERATOR STATION

This operator station will have a factory installed 4-conductor cable, which will act as a tether, with a plug on the end. The installer will need to mount the holster and receptacle. Since the communication boards are connected in series, the receptacle for the tether operator station needs to be wired into the last primary or optional operator station (if multiple recessed operator stations are installed, refer to section 5.2).

The holster is supplied with (3) 1/4-20 stainless steel self-tapping screws. Make sure the material beneath the bracket is substantial and thick enough to hold self-tapping screws. Make sure the area on the back side of the mounting surface is clear of obstructions. We recommend a minimum thickness of 3/32" (.093" - 2.4 mm) in aluminum and 5/64 (.078"-2mm) in steel. See the chart in Figure 5.3.1 to determine the correct pilot hole size.

### 5.3.1 HOLSTER MOUNTING

Select proper location for mounting holster, preferably inside a storage compartment. Panel space required will be 6.5" x 8.0" (165 x 203mm). Refer to Figure 5.3.1 for hole dimensions. Holster can be used as template.

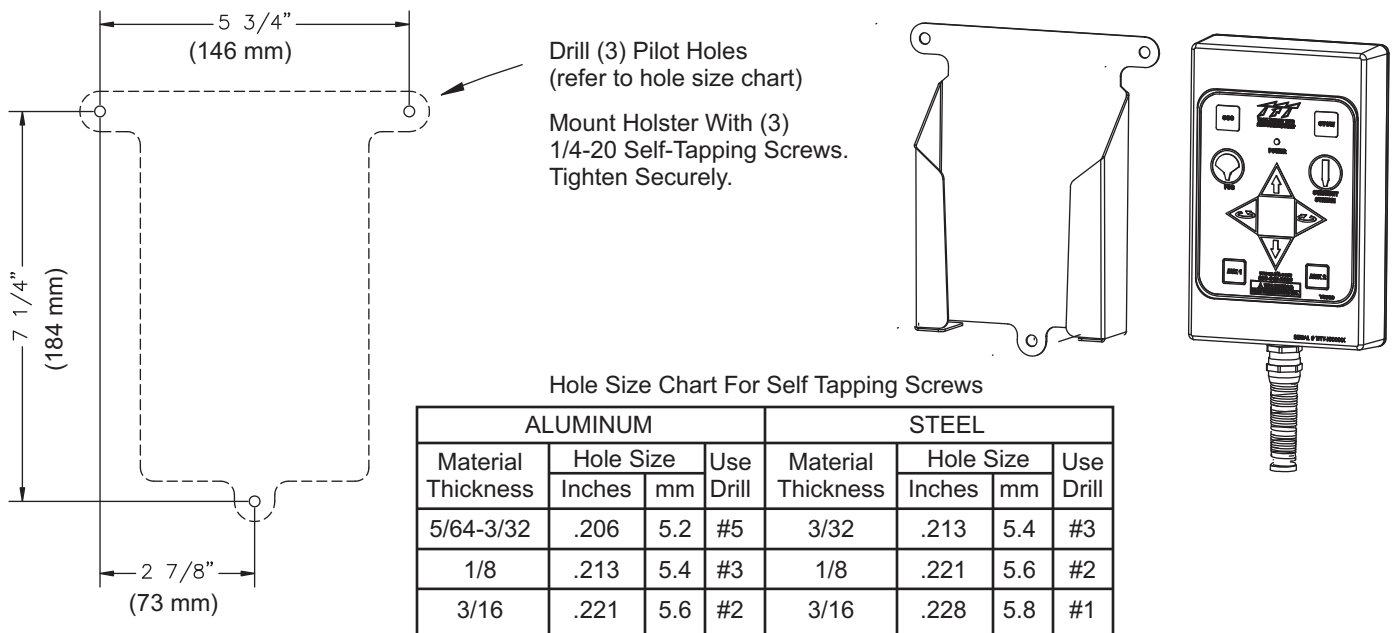

Fig 5.3.1 Tether Operator Station Holster Hole Dimensions

### 5.3.2 RECEPTACLE MOUNTING

Select proper location for mounting receptacle. Receptacle is 1-1/4" x 1-1/4" and 1/2" deep. (32 mm x 32 mm x 13 mm) Allow extra room behind receptacle for wires. Refer to Figure 5.3.2 for hole dimensions.

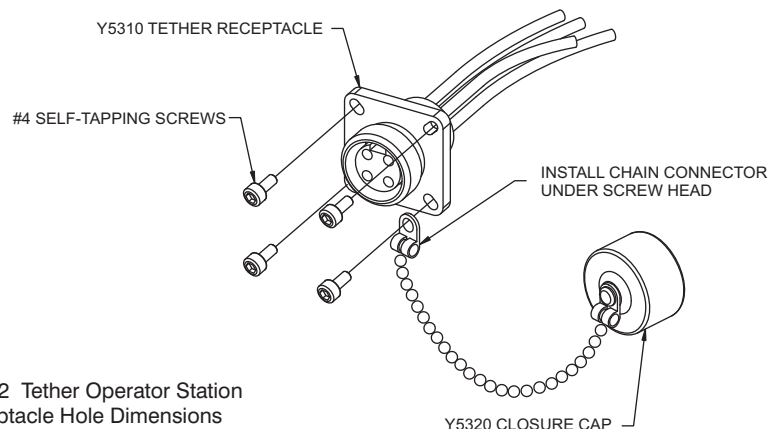
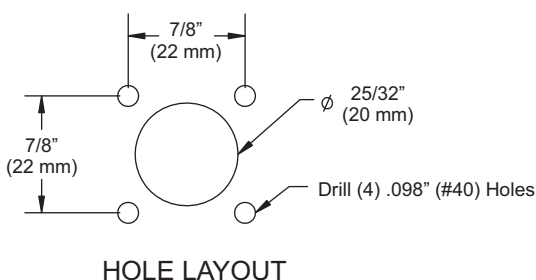

Fig 5.3.2 Tether Operator Station Receptacle Hole Dimensions

### 5.3.3 ELECTRICAL WIRING

See section 5.1.2

## 5.4 WIRELESS MONITOR OPERATOR STATION

This operator station consists of the wireless transmitter, receiver, receiver output cable, and charging cradle. The installer will need to mount the wireless receiver and wire it into the primary operator station. The charging cradle will need to be mounted in a weatherproof location and wired to a protected voltage supply.

The receiver is supplied with (2) 1/4-20 stainless steel self-tapping screws. Make sure the material beneath the receiver is substantial and thick enough to hold self-tapping screws. Make sure the area on the back side of the mounting surface is clear of obstructions. We recommend a minimum thickness of 3/32" (.093" - 2.4 mm) in aluminum and 5/64 (.078"-2mm) in steel. See the chart in Figure 5.4.1 to determine the correct pilot hole size.

### 5.4.1 MOUNTING - RECEIVER

Select proper location for mounting receiver. The receiver has a built-in antenna and needs to be in an open area so that it can receive the wireless signals. A location on the top of the truck is preferable. **The optimal operating range is 500' (150 m). Check the operating range after mounting receiver. If range is inadequate, the receiver may need to be remounted in a more exposed area.**

The receiver must be mounted so that the supplied 10' (3 m) output cable can be routed back to the primary operator station. Be sure to mount receiver so that the Deutsch connector is pointing down. Receiver size is 5.1" x 4.0" (130 x 102mm). Refer to Figure 5.4.1 for hole dimensions. Receiver can be used as template.

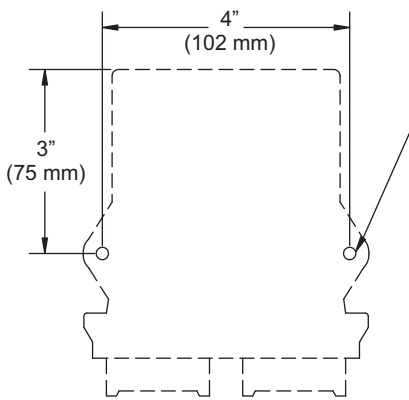
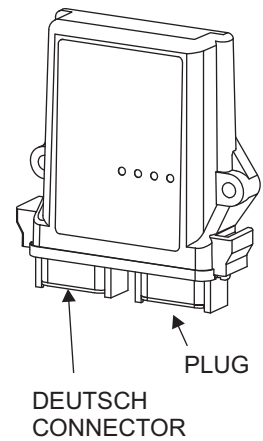

Fig 5.4.1  
Wireless Receiver Hole Dimensions

DRILL (2) PILOT HOLES (refer to hole size chart).  
MOUNT HOLSTER WITH (2) 1/4-20  
SELF-TAPPING SCREWS. TIGHTEN SECURELY.

Hole Size Chart For Self Tapping Screws

ALUMINUM				STEEL			
Material Thickness	Hole Size		Use Drill	Material Thickness	Hole Size		Use Drill
	Inches	mm			Inches	mm	
5/64-3/32	.206	5.2	#5	3/32	.213	5.4	#3
1/8	.213	5.4	#3	1/8	.221	5.6	#2
3/16	.221	5.6	#2	3/16	.228	5.8	#1



### 5.4.2 ELECTRICAL WIRING - RECEIVER TO THE PRIMARY OPERATOR STATION

See section 5.1.2

### 5.4.3 MOUNTING CHARGING CRADLE

Select proper location for mounting cradle. The cradle is not weatherproof and needs to be inside a protected location such as in the cab or a compartment. Cradle size is 4.2" x 4.5". Refer to Figure 5.4.3 for hole dimensions.

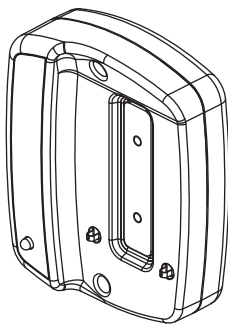

MOUNT CRADLE USING  
CUSTOMER SUPPLIED HARDWARE.  
TIGHTEN SECURELY.

Fig 5.4.3  
Charging Cradle Hole Dimensions

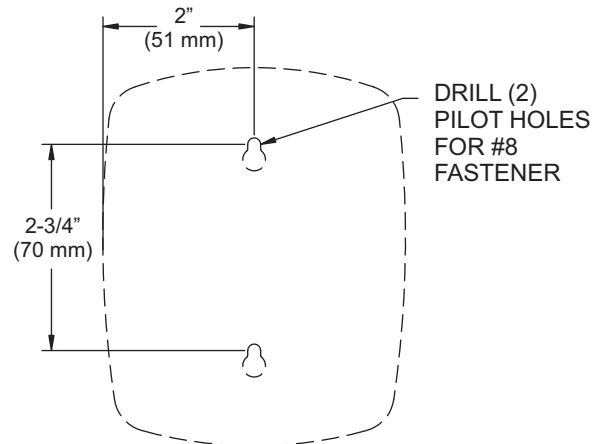

### 5.4.4 ELECTRICAL WIRING CHARGING CRADLE

Use two (2) 1/4" spade lugs to connect power to the cradle from a protected voltage supply from the truck's power distribution center. Connect the positive lead to the terminal marked CHARGE BATT and the negative (ground) lead to the terminal marked GROUND. Do not make connections to any other terminals. The circuit from the truck power distribution center should be energized continuously to keep the transmitter fully charged.



## 5.5 JOYSTICK MONITOR OPERATOR STATION

This operator station allows the monitor to be controlled by a joystick. The installer will need to mount the joystick and connect the cables to the communication interface box or to a primary operator station. The joystick needs to be mounted in a weatherproof location. Example: Inside the cab of the truck.

### 5.5.1 MOUNTING

Select proper weatherproof operating location. Joystick will require 4 1/2" x 4 1/2" (114 x 114mm) of panel space. A depth of 4" (100mm) will be required behind the panel. Refer to Figure 5.5.1.1 for hole dimensions.

After mounting, the installer may rotate the joystick up to 22 degrees in either direction. To rotate joystick, lift the rubber boot to expose adjustable clamp. Loosen the clamping screws, rotate the joystick to desired position, and tighten clamping screws.

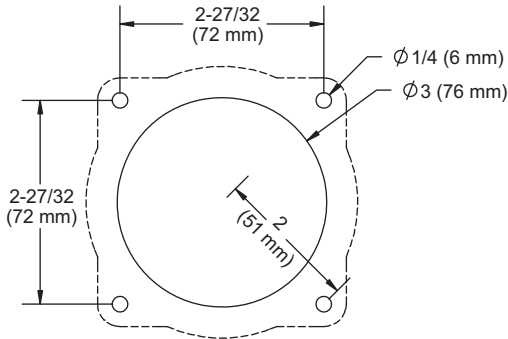

HOLE MOUNTING DETAIL

Fig 5.5.1.1  
Joystick Operator Station  
Hole Dimensions

Install joystick instruction label nearby for quick operation reference.

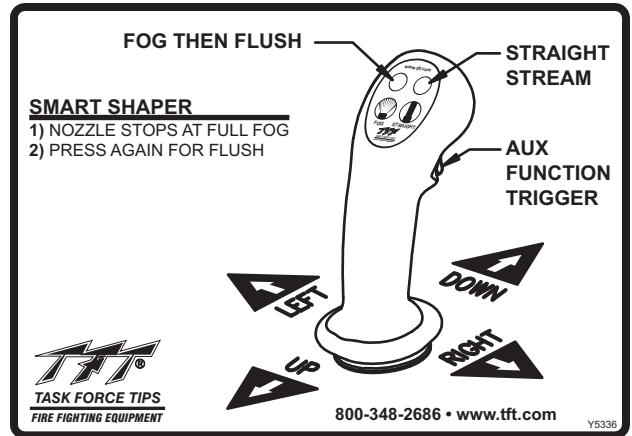

Fig 5.5.1.2  
Joystick Instruction Label

### 5.5.2 ELECTRICAL WIRING

The joystick operator station must be connected to the included Y4E-COMM Communication Interface Box or a separately supplied Y4E-RP Primary Operator Station. By connecting the joystick to a communication interface box, a primary operator station is not required and the installer has the option to enable the joystick operator station with the master override feature (see Section 6.2.2). When a pump panel operator station is being installed, the installer can connect the joystick to the Primary Operator Station, which will eliminate the need to install the communication interface box.

#### 5.5.2.1 Wiring to a Communication Interface Box

The joystick cables will be connected to the factory supplied 10' cable from the Communication Interface Box.

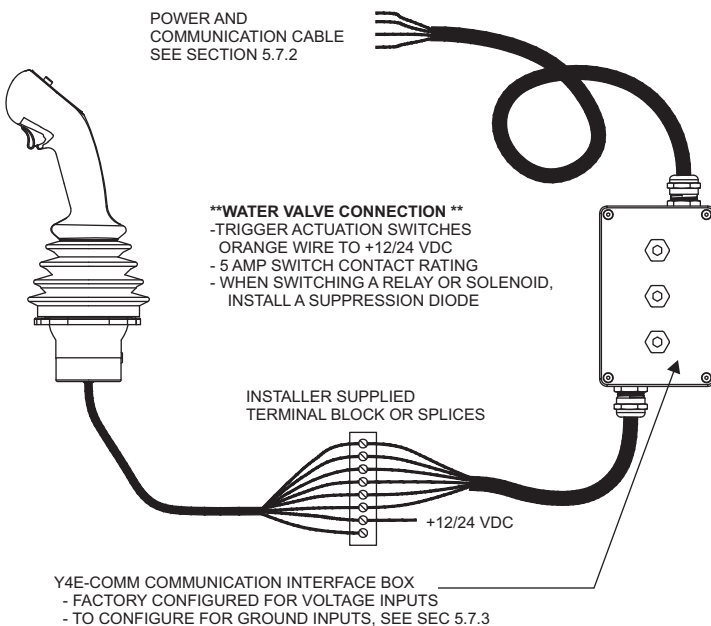

Fig 5.5.2.1  
Joystick Operator Station Wiring  
to Communication Interface Box

Function	Joystick Cable Color	Interface Box Cable Color
UP	Grey	WHITE
DOWN	Black/White	BLUE
LEFT	Tan	YELLOW
RIGHT	Pink	BROWN
COMMON	Red	+12/24 VDC
STREAM	Blue	ORANGE
FOG	Green	GREEN
TRIGGER	Orange	Water Valve**
n/u	White	n/u
n/u	Brown	n/u
n/u	Black	n/u
n/u	Purple	n/u
n/u	Yellow	n/u

**NOTE** Do not connect 12VDC to Communication Interface Box wires if configured for GROUND inputs. This will result in damage to the communication board. See section 5.7.3.

### 5.5.2.2 Wiring to a Primary Operator Station

The joystick cable will enter the primary operator station through the connector labeled WIRELESS OPER. STATION. Refer to section 5.1.2D.

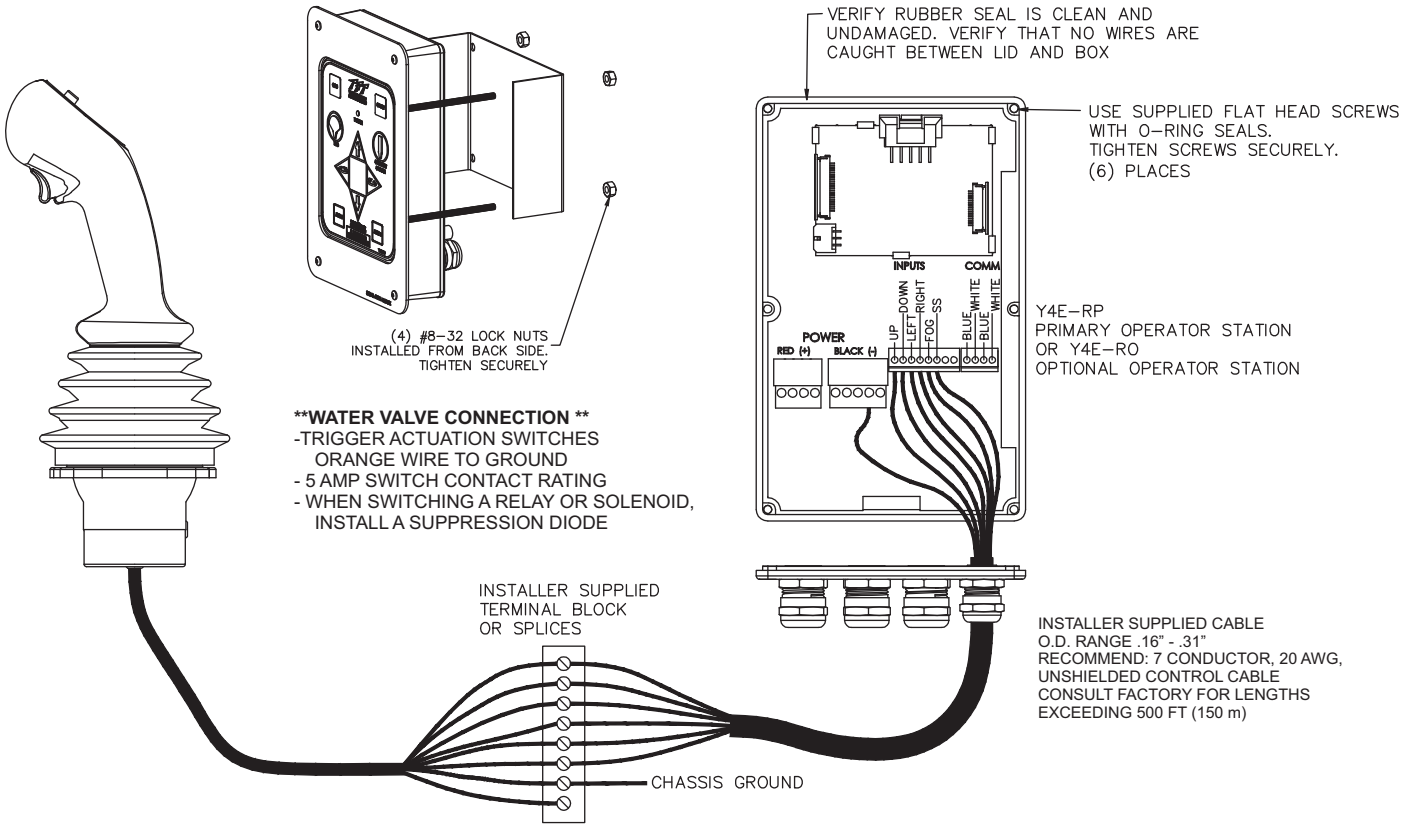

Function	Joystick Cable Color
UP	Grey
DOWN	Black/White
LEFT	Tan
RIGHT	Pink
COMMON	Red

## NOTE

Do not connect 12VDC to Primary Operator Station inputs. This will result in damage to the communication board.

Function	Joystick Cable Color
STREAM	Blue
FOG	Green
TRIGGER	Orange
n/u	White
n/u	Brown
n/u	Black
n/u	Purple
n/u	Yellow

Fig 5.5.2.2  
Joystick Operator Station Wiring  
to Primary Operator Station

### 5.6 TOGGLE SWITCH MONITOR OPERATOR STATION

This operator station allows the monitor to be controlled by three toggle switches. The installer will need to mount the operator station and connect the cable to a primary operator station or directly to the monitor.

#### 5.6.1 ENCLOSURE MOUNTING

Select proper operator location. Enclosure is designed to be surface mounted and the size is 5" x 3 1/8" (127 x 80mm). Height to top of switches is 3 1/8" (80mm). Refer to Figure 5.6.1 for mounting hole dimensions.

MOUNT ENCLOSURE WITH (2) 1/4-20 FASTENERS. TIGHTEN SECURELY.

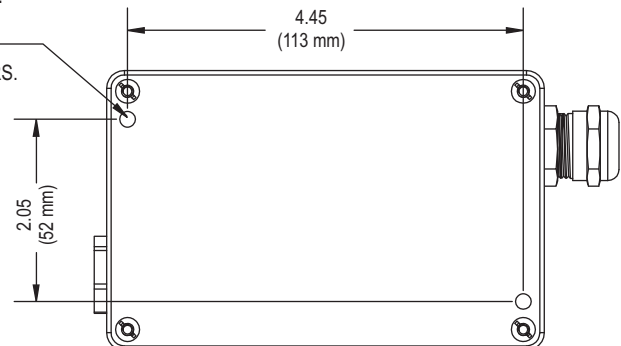

Figure 5.6.1  
Toggle Switch Operator Station  
Hole Dimensions

#### 5.6.2 ELECTRICAL WIRING

See section 5.1.2C.

## 5.7 COMMUNICATION INTERFACE BOX

This Communication Interface Box converts discrete input signals into serial communications for controlling the monitor. The discrete input signals can be from a joystick, toggle switches, relay contacts or Canbus output module. The interface box accepts +12/24 VDC signals, but can be field changed to accept ground signals. The installer will need to mount the interface box and connect the cable to a primary operator station or directly to the monitor.

### 5.7.1 ENCLOSURE MOUNTING

Select proper enclosure location. Enclosure is designed to be surface mounted and the size is 5" x 3 1/8" (127 x 80mm). Height of enclosure is 2 3/8" (60mm). Refer to Figure 5.6.1 for mounting hole dimensions.

### 5.7.2 ELECTRICAL WIRING

See section 5.1.2C for connecting power & communication cable. See figure 5.7.2 for connecting INPUTS cable.

Function	Interface Box Cable Color
UP	WHITE
DOWN	BLUE
LEFT	YELLOW
RIGHT	BROWN
FOG	GREEN
STREAM	ORANGE
SPEED	BLACK
STOW	RED

Figure 5.7.2  
Communication Interface  
Wire Color/Function

### 5.7.3 INPUTS SIGNAL CONFIGURATION

The Communication Interface Box is shipped from the factory configured to accept +12/24 VDC input signals, but can be field changed to accept ground input signals.

To change the configuration:

1. Remove lid from enclosure.
2. Locate DIP switches on communication board.
3. Slide DIP switch #4 to the OFF position to select GROUND inputs or slide switch #4 to the ON position to select VOLTAGE inputs.
4. Replace lid. Verify rubber seal is clean and undamaged. Verify that no wires are caught between lid and box.

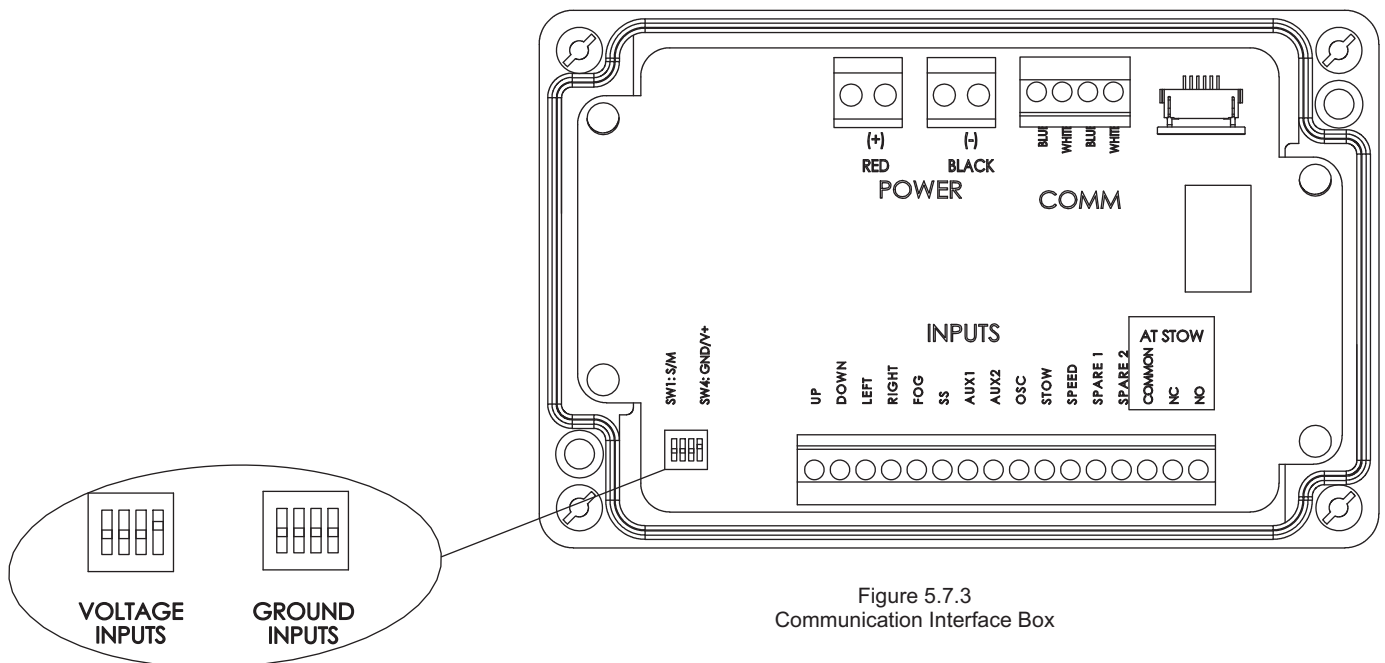

Figure 5.7.3  
Communication Interface Box

## 5.8 MONITOR POSITION DISPLAY

The monitor position display is supplied with a 10' (3 m) long 4-conductor cable. The installer will need to surface mount the enclosure in a dry area and connect the cable to power and the communication link of the monitor. Display is designed for use with 180° total horizontal axis travel.

### 5.8.1 ENCLOSURE MOUNTING

Select proper location for display. The display is not weatherproof and needs to be inside a protected area such as in the cab.

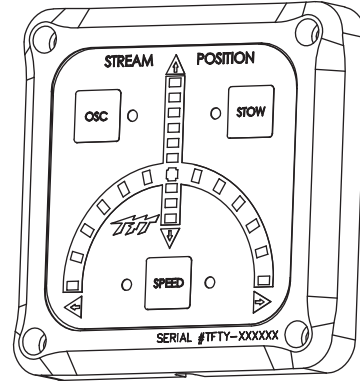
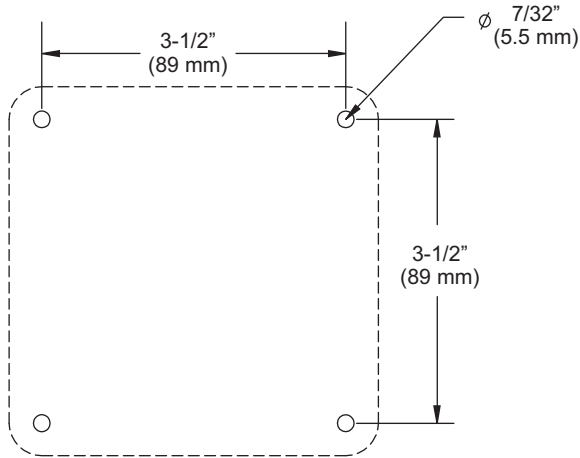

MOUNT ENCLOSURE WITH (2) #10 FASTENERS. TIGHTEN SECURELY.

Fig 5.8.1  
Monitor Position Display  
Hole Dimensions

### 5.8.2 ELECTRICAL WIRING

The monitor position display needs to be connected to +12/24VDC (red) and ground (black). The blue & white wires from the position display cable need to be connected to the blue & white wires from the monitor. A terminal box or a high quality, protected splice can be used to make these connections. See section 5.0.0 for connecting power and communication cable.

## 5.9 CONNECTING MONITOR CABLE DIRECTLY TO PROTECTED POWER SUPPLY

The electric RC monitor has an operator station, which is fully functional, mounted on the monitor. If no other operator stations are selected, the installer will only need to connect power to complete the installation.

### 5.9.1 ELECTRICAL WIRING

Route cable from monitor and connect to a protected circuit from the truck's power distribution center. Connect the red wire to positive and the black wire to negative (ground). Cut and discard blue and white wires.

## 5.10 ELECTRICAL RC MONITOR AERIAL TRUCK INSTALLATION

When installing the electric RC monitor on an aerial device truck, refer to section 5.10.2.1 or 5.10.2.2.

### 5.10.1 ELECTRONICS ENCLOSURE MOUNTING

Select proper enclosure location. Enclosure is designed to be surface mounted and the size is 5 3/4" x 8 3/4" (146 x 222mm). Height of enclosure is 2 1/4" (57mm). Refer to Figure 5.10.1 for mounting hole dimensions.

### 5.10.2 ELECTRICAL WIRING

On aerial devices the installer will supply the required cables that run up the ladder or boom. Be sure to perform voltage drop calculations to verify that the supply voltage will remain at an acceptable level during monitor operation.

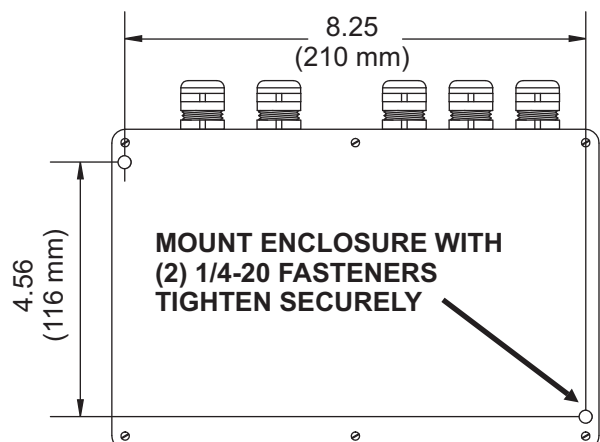

Fig 5.10.1  
Electrical Enclosure  
Mounting Hole Dimensions

### 5.10.2.1 LADDER INSTALLATION ELECTRICAL WIRING

The electronics enclosure converts discrete input signals into serial communications for controlling the monitor. The discrete input signals can be from a joystick, toggle switches, relay contacts or Canbus output module. The electronic interface accepts +12/24 VDC signals, but can be field changed to accept ground signals.

The electronics enclosure is configured so that signals connected to the PRIMARY CONTROL cable will override any other operator stations (see section 6.2.1).

See Figure 5.10.2.1 for wiring connections.

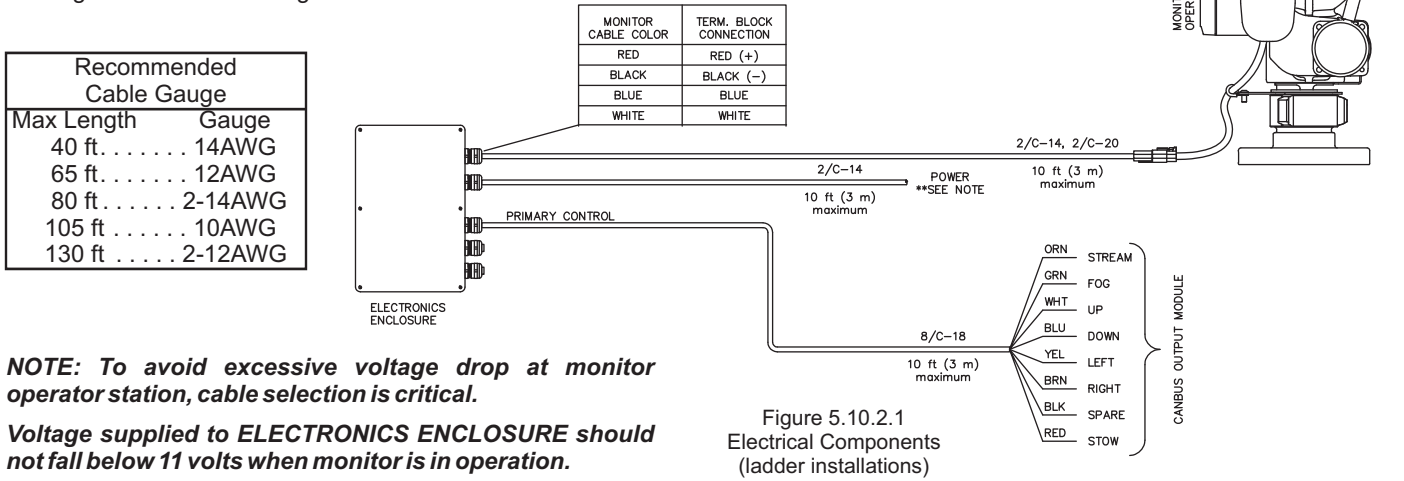

### 5.10.2.2 PLATFORM INSTALLATION ELECTRICAL WIRING

The electronics enclosure converts discrete input signals into serial communications for controlling the monitor. The discrete input signals can be from a joystick, toggle switches, relay contacts or Canbus output module. The electronic interface accepts +12/24 VDC signals, but can be field changed to accept ground signals.

The electronics enclosure is configured so that signals connected to the PRIMARY CONTROL cable will override any other operator stations (see section 6.2.1).

See Figure 5.10.2.2 for wiring connections.

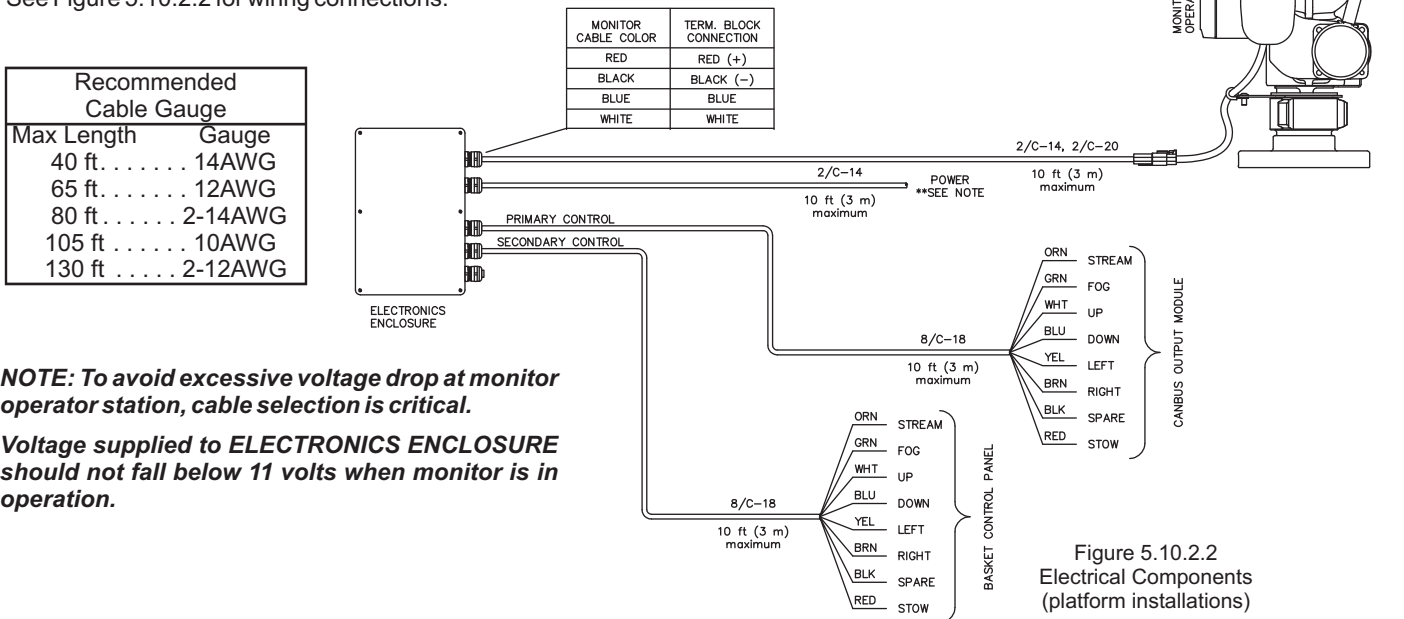

### 5.11 ELECTRIC NOZZLE ACTUATOR WIRING

The electric Tornado RC monitor is designed to control and is factory wired for a TFT electric actuated nozzle. Task Force Tips nozzles are available with a male cord plug. After mounting the appropriate nozzle onto the monitor, plug the male cord from the nozzle into the female cord located on the outlet of the monitor. Make sure the two coupling nuts are tightened securely to ensure a proper watertight seal.

If retrofitting an existing TFT nozzle, a male cord plug (TFT #Y5285) can be purchased and installed in place of the existing actuator cord. Please consult factory for installation.

## 6.0 OPERATION

### 6.1 MANUAL TILLER MODEL

#### 6.1.1 HORIZONTAL ROTATION AND ROTATION LOCK

The horizontal rotation of the stream is changed by pushing or pulling horizontally on the Tornado's Tiller Bar. Twisting the Horizontal Rotation Locking Knob clockwise will increase the drag on the swivel joint to "lock" the monitor in a particular direction.

#### 6.1.2 ELEVATION CONTROL AND ELEVATION ROTATION LOCK

The elevation of the stream is changed by pushing or pulling vertically on the Tornado's Tiller Bar. Twisting the Elevation Locking Knob clockwise will increase the drag on the swivel joint to "lock" the monitor at a particular elevation. Select discharge devices that do not exceed the 25 ft-lb locking capability of the elevation lock.

#### 6.1.3 COUNTER BALANCING NOZZLE, IF DESIRED

The weight of the nozzle will make the elevation swing downward quickly when the Locking knob is loosened, unless the Tiller Handle is held. If this is undesirable, then weight may be attached to the Tiller Handle to counterbalance the weight of the nozzle. If weight is added, assure that it is securely attached and does not interfere with operation of the monitor.



**Master stream flows are very powerful and capable of causing injury and property damage. Make sure the monitor is pointing in a safe direction before water to the monitor is turned on. Use care in directing the stream.**



**Care must be taken when loosening the Elevation Locking Knob so the nozzle does not swing down quickly. Keep one hand on the Tiller Bar while loosening the Elevation Locking Knob. Be prepared to exert force on the Tiller Bar as the Knob is loosened.**



**When water pressure is reduced, the nozzle will swing down if the Elevation Locking Knob is not adequately tightened.**

### 6.2 ELECTRICAL MODEL

#### 6.2.1 OPERATOR STATIONS

The electric Tornado RC monitor has six different styles of operator stations for use in various locations on the apparatus or scene.

##### 6.2.1.1 MONITOR MOUNTED OPERATOR STATION

This operator station is factory installed on the monitor and is used by personnel directly at the monitor.

##### 6.2.1.2 PRIMARY OPERATOR STATION

This operator station is installed on the truck, for example the pump operator's panel. It is used to operate the monitor from a location on the truck. Commands from the primary operator station will override the monitor mounted operator station.

##### 6.2.1.3 OPTIONAL OPERATOR STATION

This operator station allows the monitor to be operated from an additional location on the truck. Commands from the optional operator station will override the monitor mounted operator station.

##### 6.2.1.4 TETHER OPERATOR STATION

This operator station is tethered to the truck with either a 30 foot (9 meter) cable or a 100 foot (30.5 meter) cable. Operating slightly away from the truck gives a better view for redirecting the monitor. Commands from the tether operator station will override the monitor mounted operator station.

##### 6.2.1.5 WIRELESS OPERATOR STATION

This operator station uses RF signals to control the monitor. It is used to move far away from the truck to get a better view for redirecting the monitor. Maximum range is 500 ft (150 meters). The wireless transmitter is coded to a particular monitor so several wireless monitors may be in use at the same location without interference. It uses rechargeable batteries that will give 160 hours of continuous operation when fully charged. When not in use, the wireless transmitter should be kept in its charging base. The transmitter will turn on a red LED to warn the operator when the battery charge is low. After this point, there are less than 8 hours of continuous use available.

To activate the transmitter, press the green button at the top. While the transmitter is active, the yellow LED will blink continuously.

Pressing the red button at the bottom will deactivate the transmitter. The transmitter will automatically deactivate after 10 minutes if no buttons are pressed.

##### 6.2.1.6 JOYSTICK OPERATOR STATION

This operator station is installed in a protected location and allows the monitor to be controlled by a joystick.

##### 6.2.1.7 TOGGLE SWITCH OPERATOR STATION

This operator station allows the monitor to be operated by three toggle switches.



## 6.2.2 MASTER OVERRIDE FEATURE (DIP #1)

Any operator station with a communication board can be reconfigured with the master override feature. These stations include the Y4E-RP, Y4E-RO, Y4E-CT-30, Y4E-CT-100, Y4E-TS, or any inputs connected to an Y4E-COMM. To enable the master override feature on an operator station, follow these steps:

1. Remove lid from enclosure.
2. Locate DIP switches on communication board.
3. Slide DIP switch #1 to the ON position.
4. Replace lid. Verify rubber seal is clean and undamaged.  
Verify that no wires are caught between lid and box.

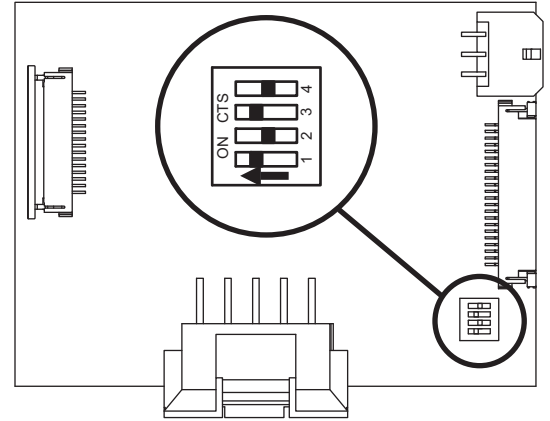

Figure 6.2.2  
Master Override Setup

## 6.2.3 STOW FEATURE

The STOW position needs to be programmed during installation. The monitor needs to “find” two (2) hard stops, one for each axis, before the monitor can move to the STOW position. When programming, the first two commands teach the monitor where to find the hard stops. This guarantees that the position is accurate. From that point, the operator can program the move to the final STOW position.

During normal operation, each time the STOW button is pressed, the monitor moves the nozzle to the full straight stream position, moves to each programmed hard stop, and then moves to the STOW position. While the monitor is performing the STOW feature, pressing any button will stop the monitor.

### 6.2.3.1 PROGRAMMING

STOW programming must be initiated within 1 minute of applying power to monitor. After 1 minute, programming access is blocked. Power must then be cycled to reset 1 minute timer.

Press & hold STOW button (~10 seconds) until LED blinks. Release button. LED will continue to blink while in program mode.

#### FIRST AXIS TO MOVE:

Press & release LEFT/RIGHT or UP/DOWN button of axis that will move to first hard stop. LED will blink rapidly when hard stop is reached.

#### SECOND AXIS TO MOVE:

Press & release LEFT/RIGHT or UP/DOWN button of axis that will move to second hard stop. LED will blink rapidly when hard stop is reached.

#### MOVE TO STOW POSITION:

Use LEFT/RIGHT or UP/DOWN buttons to move monitor to first point of stow routine, press & release STOW button. LED will blink rapidly to acknowledge position.

Repeat until pattern is complete (up to 10 points).

Press & hold STOW button until LED turns off. Release button.

### 6.2.3.2 STOW PROGRAMMING EXAMPLE

- Press & hold STOW button until LED blinks.
- Press & release UP button, monitor will move until hard stop reached. LED blinks rapidly.
- Press & release RIGHT button, monitor will move until hard stop reached. LED blinks rapidly.
- Press LEFT button to move 45 degrees, Press & release STOW button. LED blinks rapidly.
- Press DOWN button to move 90 degrees, Press & release STOW button. LED blinks rapidly.
- Press & hold STOW button until LED turns off.

## 6.2.4 OSCILLATE FEATURE

The OSCILLATE feature allows the user to program a repeating pattern to control the horizontal and vertical axes of the monitor. While in the OSCILLATE pattern, the monitor will pause while the user changes the stream pattern. Pressing any other button will stop the OSCILLATE pattern.

A label is supplied with each operator station that can be mounted on or near the station as a reminder of how to program the OSCILLATE pattern. The OSCILLATE pattern needs to be programmed before use. The pattern will be cleared each time power is cycled to the monitor. For fixed monitors, the monitor may be configured to store the program permanently. See Section 6.2.4.2.

### 6.2.4.1 PROGRAMMING

- Move monitor to starting point of pattern.
- Press & hold OSC button (~5 seconds) until LED blinks. Release button. LED will continue to blink while in program mode.
- Move monitor to 2nd point, press OSC button. LED will blink rapidly to acknowledge position.
- Repeat until pattern is complete (up to 65 points).
- Press & hold OSC button until LED turns off. Release button.

<p><b>TO OSCILLATE:</b> Press &amp; release OSC button. (Pattern must be programmed first.)</p>	<p><b>TO STOW:</b> Press &amp; release STOW button. (Programmable, refer to manual.)</p>	
<p><b>OSCILLATE PATTERN PROGRAMMING:</b></p> <ol style="list-style-type: none"> <li>1) Move monitor to starting point of pattern.</li> <li>2) Press &amp; hold OSC button until LED blinks. LED will continue to blink in program mode.</li> <li>3) Move monitor to 2nd point, press OSC button. LED will blink rapidly to acknowledge position.</li> <li>4) Repeat until pattern is complete.</li> <li>5) Press &amp; hold OSC button until LED turns off.</li> </ol> <p><b>NOTE: PATTERN WILL BE CLEARED UPON POWER LOSS.</b></p>		
		<p><b>800-348-2686</b> <b>www.tft.com/tornado</b></p> <p style="text-align: right;">Y5705</p>

Figure 6.2.4.1  
Operator Station Label

### 6.2.4.2 OSCILLATE PATTERN RETAIN FEATURE (DIP #4)

The monitor can be configured so that upon power up, the OSCILLATE pattern is retained. The OSCILLATE pattern will need be programmed at least one time (see section 6.2.4.1). To enable the OSCILLATE pattern retain feature on a monitor follow these steps:

1. Remove lid from monitor operator station.
2. Locate DIP switches on communication board.
3. Slide DIP switch #4 to the ON position.
4. Replace lid. Verify rubber seal is clean and undamaged. Verify that no wires are caught between lid and box.
5. Program OSCILLATE pattern.

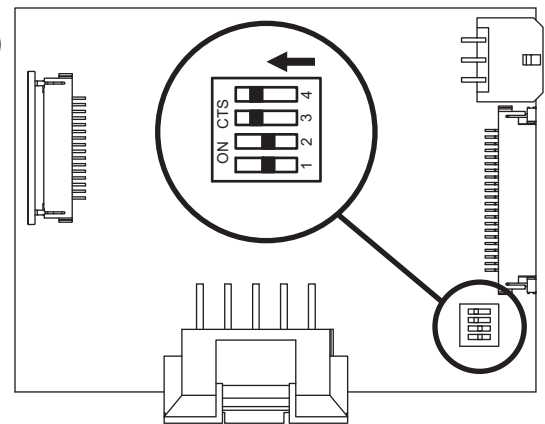

Figure 6.2.4.2  
Oscillate Pattern Retain Setup

### 6.2.5 OPERATOR STATION PANELS

The operator stations are all equipped with the same monitor movement functions. From the operator stations, the operator can command the monitor up, down, left, right and command the nozzle pattern shaper from fog to straight stream. Operator stations supplied with the membrane switch, shown on the left below, allow the operator to program and perform the oscillate and stow features.

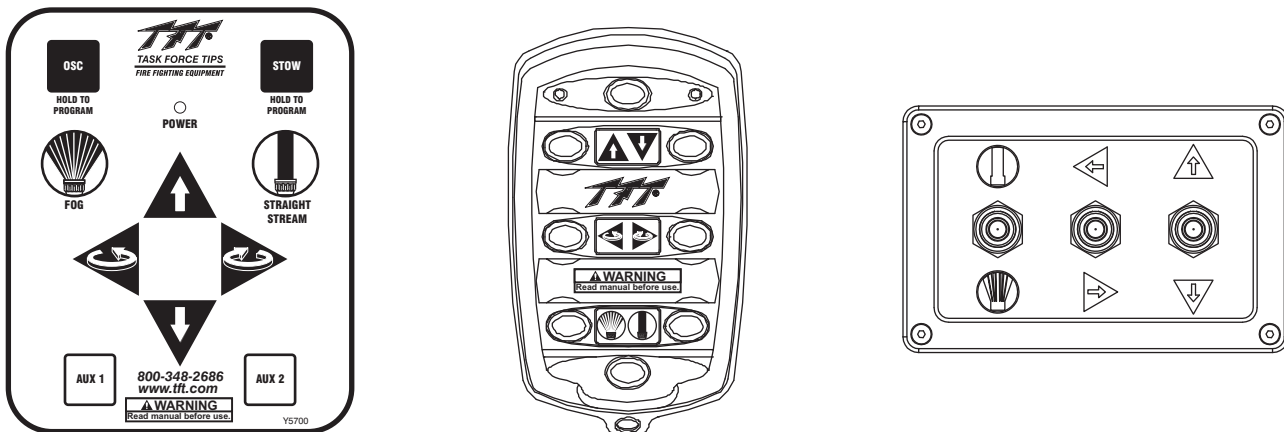

Fig 6.2.5  
Operator Station Button Layouts

### 6.2.6 OVERRIDE KNOBS

In the event of electrical system failure on the monitor or fire apparatus, the Tornado RC Monitor is factory supplied with override knobs so the monitor may be manually operated. If desirable, the override knobs may be removed. The drive shafts have a hex so a wrench or socket may be used for manual override. The wrenching hexes are shown in figure 6.2.3.

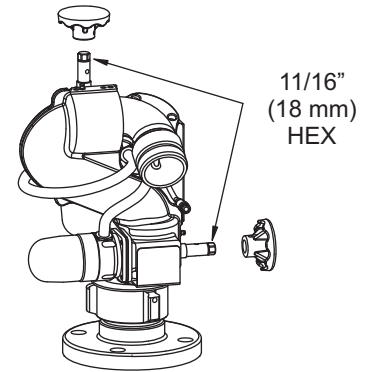

Fig 6.2.3  
Wrenching Hexes on Drive Shafts

### 6.3 RECOMMENDED STOWING POSITION

For truck mounted applications, it is recommended that the monitor be stowed in a position such that the monitor's nozzle rests against a bracket or support surface. This will minimize bouncing of the nozzle when the apparatus is traveling. **Always be sure the monitor is properly stowed before moving the truck and know the overall height to avoid damage from overhead obstructions such as doors or bridges.**

### 6.4 FLOWS AND PRESSURES

#### 6.4.1 STACKED TIPS FLOW

NOZZLE DIAMETER	NOZZLE INLET PRESSURE									
	50 PSI		80 PSI		100 PSI		150 PSI		175 PSI	
	FLOW (GPM)	REACTION (LBS)	FLOW (GPM)	REACTION (LBS)	FLOW (GPM)	REACTION (LBS)	FLOW (GPM)	REACTION (LBS)	FLOW (GPM)	REACTION (LBS)
1.0 INCH	210	80	270	120	300	150	360	230	390	260
1-1/4 INCH	330	120	410	190	460	230	—	—	—	—
1-1/2 INCH	470	170	—	—	—	—	—	—	—	—

NOZZLE DIAMETER	NOZZLE INLET PRESSURE									
	4 BAR		6 BAR		8 BAR		10 BAR		12 BAR	
	FLOW (L/min)	REACTION (KG)	FLOW (L/min)	REACTION (KG)	FLOW (L/min)	REACTION (KG)	FLOW (L/min)	REACTION (KG)	FLOW (L/min)	REACTION (KG)
25 MM	830	40	1000	60	1200	80	1300	100	1400	120
32 MM	1300	70	1700	100	1900	130	—	—	—	—
38 MM	1900	90	—	—	—	—	—	—	—	—

**FLOW EXCEEDS RATING OF TORNADO MONITOR**

Fig 6.4.1  
Stacked Tips Flow Table

#### 6.4.2 TORNADO MONITOR AND STREAM STRAIGHTENER FRICTION LOSS

See figure 6.4.2 for Tornado Monitor and Task Force Tips 5 and 10 inch Stream Straightener friction loss.

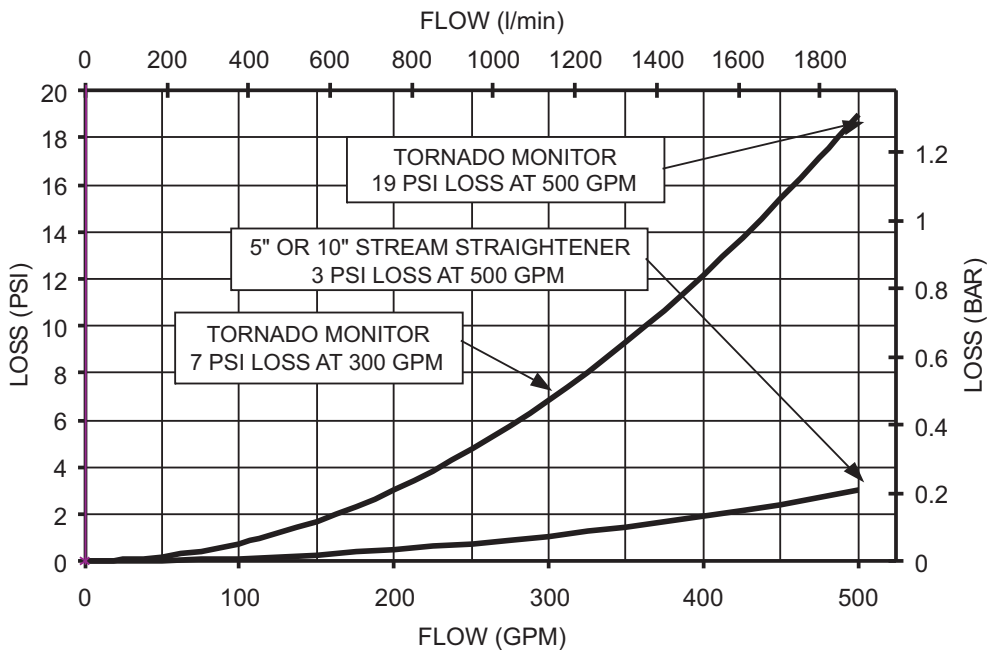

Fig 6.4.2  
Friction Loss

## **6.5 STREAM STRAIGHTENERS**

### **6.5.1 STREAM STRAIGHTENERS WITH STACKED TIP NOZZLES**

Turbulence though the Tornado Monitor is very low, but stream quality and reach can be improved with the use of a stream straightener on the TFT stacked tip nozzle. See figure 6.4.2 for the TFT stream straightener friction loss.

### **6.5.2 STREAM STRAIGHTENERS WITH FOG NOZZLES**

When using a fog nozzle for flows below 300 gpm (1,100 l/min), it is recommended that no stream straightener be used since the fog nozzle's flow path generally serves as a stream straightener. Above 300 gpm (1,100 l/min), TFT's 5 inch Stream Straightener will generally improve a fog nozzle's stream.

## **7.0 MAINTENANCE AND INSPECTION**

The Tornado Monitor requires little maintenance. The monitor should be kept clean and free of dirt. All controls should be checked for freedom of movement and proper operation periodically. Any inoperable or damaged parts should be repaired or replaced immediately.

- Make sure that the monitor rotates freely and without binding throughout its range of travel.
- Make sure that there are no leaks when the monitor is flowing water.
- Make sure the nozzle is free of debris.

### **7.1 LUBRICATION**

The Tornado monitor generally should not require greasing. In the event that the operation becomes stiff, grease may be applied to the horizontal rotation and elevation worm gears. See figure 3.2B for grease port locations. Use medium viscosity automotive chassis grease. Apply only enough grease to restore normal operation. If normal operation is not restored by greasing, inspect for other causes of stiff operation.

Note: Do not over pump grease. The grease fittings are located close to the seals and only an ounce or so of grease should be sufficient.

### **7.2 PERFORMANCE TESTING**

Performance tests should be conducted on the Tornado Monitor after repairs are made, or any time a problem is reported to verify operation in accordance with Task Force Tips test procedures. Consult the factory for the procedure that corresponds to the model and serial number of your monitor. Any equipment that fails the test criteria should be removed from service immediately. Equipment can be returned to the factory for service and testing.

## 8.0 TROUBLESHOOTING

SYMPTOM	POSSIBLE CAUSE	REMEDY
Leaks	Debris or damage in seal area	Clean out debris or replace damaged parts
Elevation Binding	Debris or damage to elevation drive parts	Clean out debris or replace damaged parts
	Lack of lubricant	Grease, see section 7.1
Horizontal Rotation Binding	Debris or damage to horizontal drive parts	Clean out debris or replace damaged parts
	Lack of lubricant	Grease, see section 7.1
No Power LED	Polarity reversed	Check wiring and reverse polarity
Power LED On But No Operation	Low voltage due to: <ul style="list-style-type: none"> <li>- wire gage too small</li> <li>- wire length too long</li> <li>- poor connection</li> <li>- inadequate apparatus electrical system</li> </ul>	Check connections and wiring per section 5.1.2
Operation only from monitor operator station. STOW, & OSC LED's blink when button pressed.	Incorrect wiring	Check blue/white communication wiring
Operation only from monitor control station	Communication board code version incompatible	Verify code versions on monitor and all operator stations
One Axis Fails To Operate From Any Control Station	Loose motor wiring connection	Check axis motor connection
	Bad control board	Interchange control boards and check if problem persists with same axis, If not, replace control board.
	Bad motor	Interchange control boards and check if problem persists with same axis, If yes, replace motor.
	Bad membrane switch	Replace membrane switch / operator station
Vertical/Horizontal axis will not speed up	Loose encoder wiring connection	Check axis encoder connection
	Bad motor encoder	Interchange control boards and check if problem persists with same axis. If yes, replace motor.  Remove encoder cover and check for RED light just below disk. If no light, encoder is bad. Replace motor.
Vertical/Horizontal axis runs only in fast speed	Loose encoder wiring connection	Check axis encoder connection
	Bad motor encoder	Interchange control boards and check if problem persists with same axis. If yes, replace motor.  Remove encoder cover and check for RED light just below disk. If no light, encoder is bad. Replace motor.
Vertical/Horizontal axis only runs ~5 seconds and then stops.	Loose encoder wiring connection	Check axis encoder connection.
	Bad motor encoder	Interchange control boards and check if problem persists with same axis. If yes, replace motor.  Remove encoder cover and check for RED light just below disk. If no light, encoder is bad. Replace motor.

## 9.0 TORNADO DRAWING & PARTS LIST

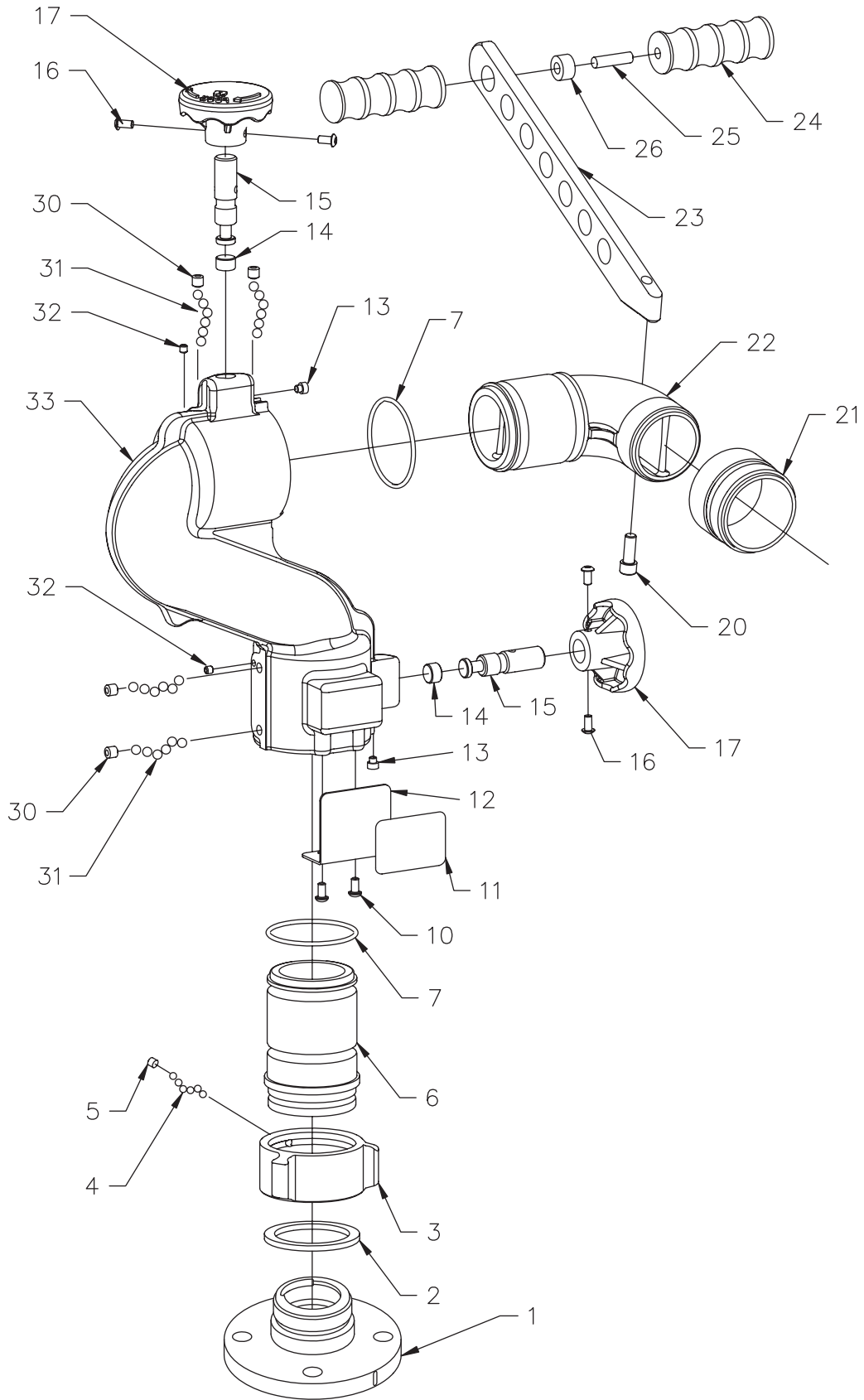

Fig 9.0A  
Manual Tornado Exploded View



#	DESCRIPTION	QTY	PART #
1	QUICK CONNECT 2.0"NPT FEMALE ALUMINUM QUICK CONNECT 2.5"NPT FEMALE ALUMINUM QUICK CONNECT 3.0"NPT FEMALE ALUMINUM QUICK CONNECT 2.0"BSP FEMALE ALUMINUM QUICK CONNECT 2.5"BSP FEMALE ALUMINUM QUICK CONNECT 2.5" ANSI 150 FLANGE ALUMINUM CODE-RLF ALUMINUM	1	Y2420A Y2400A Y2403A Y2425A Y2405A Y2430A Y2413A
2	GASKET - 2.5" HOSE COUPLING	1	V3190
3	COUPLING 2.5"NH	1	M307N
4	3/16" BALL - 302 STAINLESS STEEL	48	V2120
5	1/4-28 X 1/2 SOCKET SET SCREW	1	VT25-28SS500
6	BASE TILLER ALUMINUM	1	Y2410A
7	O-RING-233 2-7/8 ID X 1/8 C/S	2	VO-233
10	1/4-28 X 1/2 BUTTON HEAD CAP SCREW	2	VT25-28BH500
11	NAME LABEL: TORNADO MONITOR	1	Y2124
12	LABEL BRACKET	1	Y2120
13	3/8-24 X 3/8 DOG POINT	2	H515
14	WEAR DISC	2	Y4191
15	LOCKING BOLT	2	Y2318
16	1/4-20 X 1/2 BUTTON HEAD CAP SCREW	4	VT25-20BH500
17	LOCKING KNOB	2	Z245
20	3/8-16 X 1 SOCKET HEAD CAP SCREW	1	VT37-16SH1.0
21	THREAD ADAPTER 2.5"NH THREAD ADAPTER 1.5"NH THREAD ADAPTER 2.5"BSP	1	Y2320ANJ Y2320ANF Y2320ABJ
22	TILLER EXIT ELBOW ALUMINUM	1	Y2315A
23	TILLER BAR	1	Y2316
24	PEG	2	X362
25	3/8-16 X 1 3/4 STUD	1	VT37-16SD1.7
26	HANDLE BUSHING	1	Y2317
30	3/8-24 X 3/8 SOCKET SET SCREW CUP POINT	4	VT37-24SS375
31	BALL 5/16" TORLON	120	VB.312TO
32	1/4-28 X 3/16 SOCKET SET SCREW	2	VT25-28SS187
33	LOWER SECTION TILLER ALUM	1	Y2115A

# 9.0 TORNADO RC DRAWING & PARTS LIST

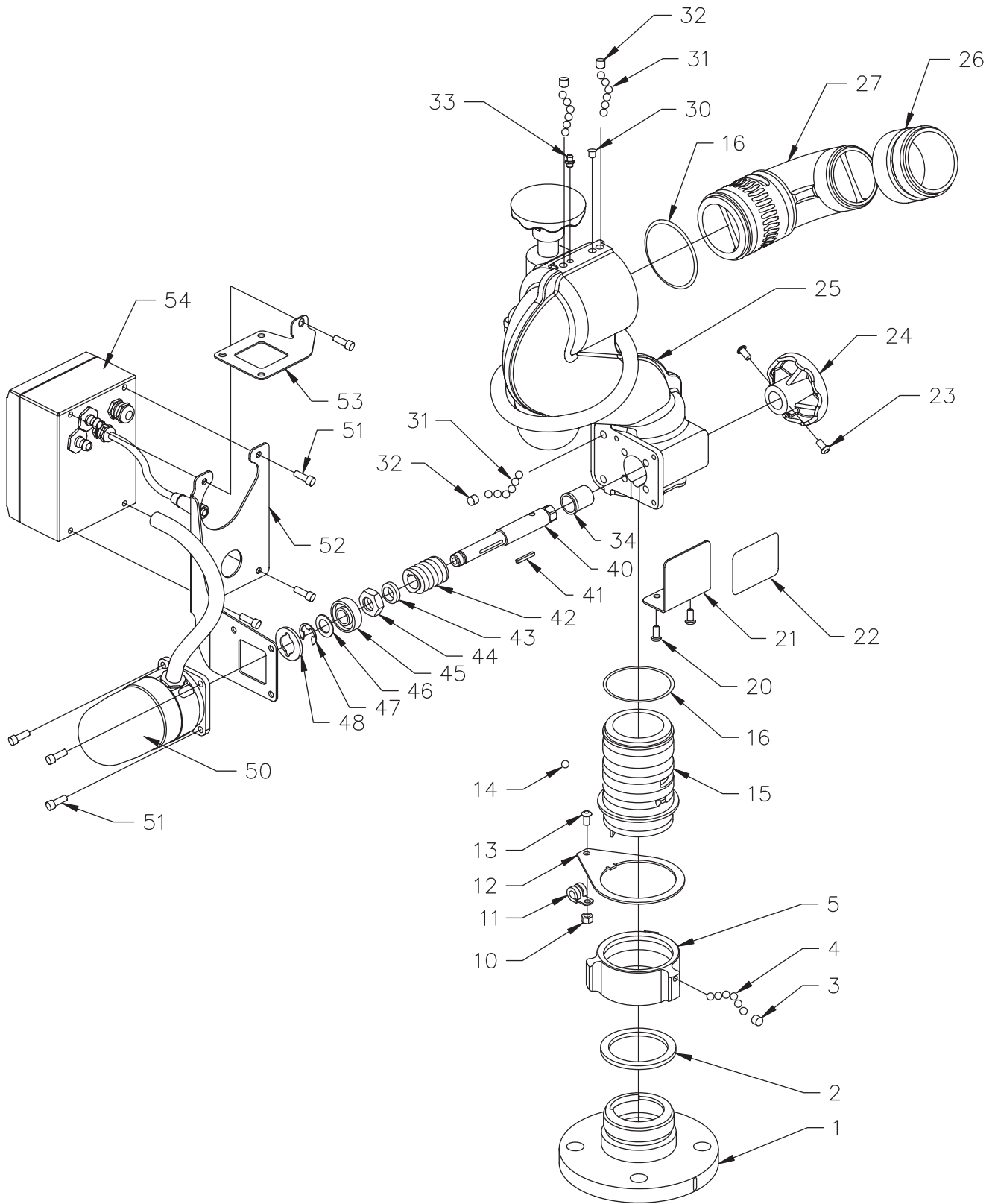
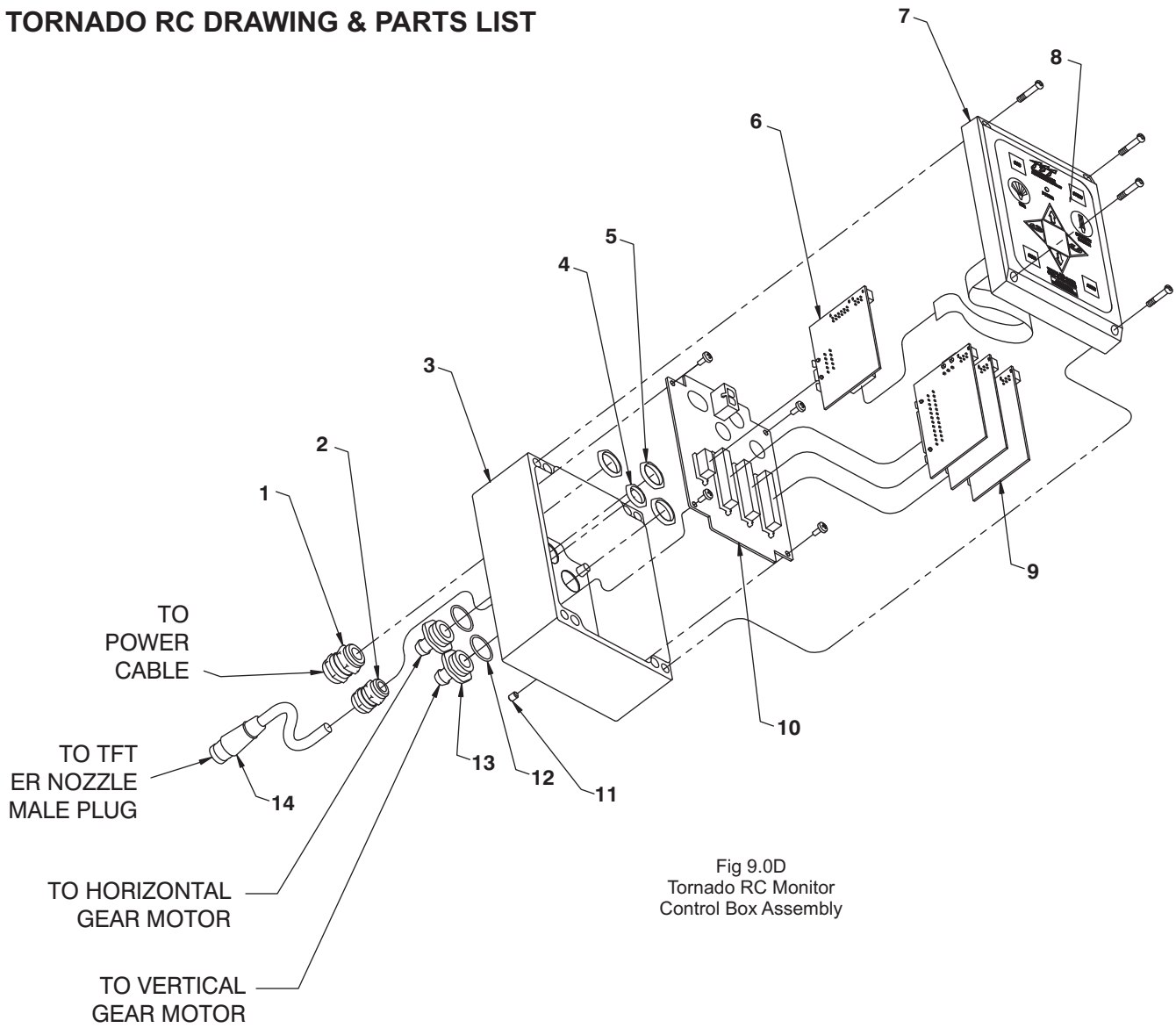

Fig 9.0B  
Tornado RC Exploded View

#	DESCRIPTION	QTY	PART #
1	QUICK CONNECT 2.0"NPT FEMALE ALUMINUM QUICK CONNECT 2.5"NPT FEMALE ALUMINUM QUICK CONNECT 3.0"NPT FEMALE ALUMINUM QUICK CONNECT 2.0"BSP FEMALE ALUMINUM QUICK CONNECT 2.5"BSP FEMALE ALUMINUM QUICK CONNECT 2.5" ANSI 150 FLANGE ALUMINUM CODE-RLF ALUMINUM	1	Y2420A Y2400A Y2403A Y2425A Y2405A Y2430A Y2413A
2	GASKET - 2.5" HOSE COUPLING	1	V3190
3	1/4-28 X 1/2 SOCKET SET SCREW	1	VT25-28SS500
4	3/16" BALL - 302 STAINLESS STEEL	48	V2120
5	COUPLING 2.5"NH	1	M307N
10	1/4-20 HEX NUT	1	VT25-20NT
11	3/8 LOOP CLAMP	1	Y4655
12	WIRE CLAMP BRACKET	1	Y2135
13	1/4-20 X 3/8 BUTTON HEAD CAP SCREW	1	VT25-20BH375
14	BALL 5/16" STAINLESS	1	VB.312
15	BASE - QUICK CONNECT ALUMINUM	1	Y2415A
16	O-RING-233 2-7/8 ID	2	VO-233
20	1/4-28 X 1/2 BUTTON HEAD CAP SCREW	2	VT25-28BH500
21	LABEL BRACKET	1	Y2120
22	NAME LABEL: TORNADO RC	1	Y2122
23	1/4-20 X 1/2 BUTTON HEAD CAP SCREW	4	VT25-20BH500
24	OVERRIDE KNOB	2	Y4165
25	LOWER SECTION RC ALUMINUM	1	Y2110A
26	THREAD ADAPTER 2.5"NH MALE ALUMINUM THREAD ADAPTER 1.5"NH MALE ALUMINUM THREAD ADAPTER 2.5"BSP MALE ALUMINUM	1	Y2320ANJ Y2320ANF Y2320ABJ
27	EXIT ELBOW ALUMINUM	1	Y2310A
30	BLACK DOME PLUG	2	VM4124
31	BALL 5/16" TORLON	120	VB.312TO
32	3/8-24 X 3/8 SOCKET SET SCREW CUP POINT	4	VT37-24SS375
33	GREASE FITTING	2	VT25-28ZERK
34	HEADED BUSHING	2	Y4141
40	DRIVE SHAFT	2	Y4163
41	KEY; 1/8" X 1.00"	2	X225
42	WORM DOUBLE LEAD	2	Y2150
43	MALE THREADED BUSHING	2	Y2175
44	FEMALE THREADED BUSHING	2	Y2176
45	BEARING, CLASS C2	2	VM4252
46	WASHER	2	VW97X595-048
47	E-CLIP 5/8" EXTERNAL	2	VR4295
48	BEARING RETAINER	2	Y2160
50	MOTOR SUBASSEMBLY, SEE FIG 9.0C	2	Y4951
51	1/4-28 X 5/8 SOCKET HEAD CAP SCREW	10	VT25-28SH625
52	CONTROL BOX BRACKET	1	Y2130
53	CONTROL BOX SUPPORT	1	Y2131
54	CONTROL BOX SUBASSEMBLY, SEE FIG 9.0D	1	

## 9.0 TORNADO RC DRAWING & PARTS LIST



#	DESCRIPTION	QTY.		PART NO.
1	CABLE FITTING PG11	1		Y5205
2	CABLE FITTING PG9	1		Y5245
3	ENCLOSURE - BOX	1		Y5115
4	LOCKNUT - PG9	1		Y5246
5	LOCKNUT - PG11	3		Y5206
6	BOARD - COMMUNICATION	1		Y5110
7	ENCLOSURE - LID	1		Y5115
8	CONTROL SWITCH PAD	1		Y5700
9	BOARD - MOTOR CONTROL	3		Y5100
10	BOARD - MAIN	1		Y5105
11	V10-32 x 1/4 SET SCREW	1		VT10Y32SS250
12	O-RING-018	2		VO-018
13	CONDUIT HOSE FITTING	2		Y5213
14	FEMALE PLUG - 2 POLE	10" TOTAL	5" EXPOSED CABLE	Y5280
	FOR TORNADO RC NOZZLE CONNECTION	LENGTH USED	(NOT INCLUDING PLUG)	

## 9.0 TORNADO RC DRAWING & PARTS LIST

#	DESCRIPTION	QTY	PART #
1	6-32 x 5/16 LONG SHCS WITH HEAD SEAL	4	VT06S32SH312
2	CUP SEAL 1.0625 x .5625 x 1/4	1	Y4620
3	MOTOR SOCKET, ANGLED FITTING	1	Y4617
4	O-RING-018, 3/4 ID 1/16 CS	1	VO-018
5	CONDUIT FITTING	1	Y5213
6	HOSE - 3/8" ID PUSH-LOK	1	Y5250
7	O-RING-038, 2-5/5 ID 1/16 CS	1	VO-038
8	GEAR MOTOR WITH ENCODER	1	Y4611
9	ENCLOSURE	1	Y4616

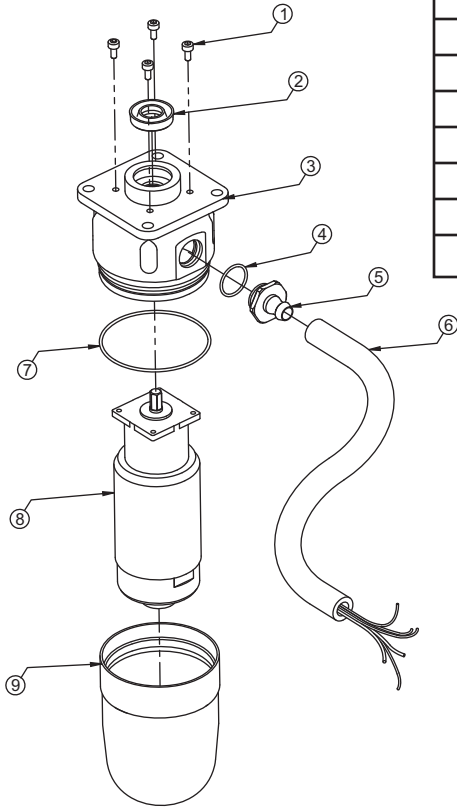

Fig 9.0C  
Motor Subassembly

## 10.0 WARRANTY

Task Force Tips, Inc., Valparaiso, Indiana 46383-6940 ("TFT") warrants to the original purchaser of its Tornado and Tornado RC Monitor ("equipment"), and to anyone to whom it is transferred, that the equipment shall be free from defects in material and workmanship during the five (5) year period from the date of purchase.

TFT's obligation under this warranty is specifically limited to replacing or repairing the equipment (or its parts) which are shown by TFT's examination to be in a defective condition attributable to TFT. To qualify for this limited warranty, the claimant must return the equipment to TFT, at 2800 East Evans Avenue, Valparaiso, Indiana 46383-6940, within a reasonable time after discovery of the defect. TFT will examine the equipment. If TFT determines that there is a defect attributable to it, it will correct the problem within a reasonable time. If the equipment is covered by this limited warranty, TFT will assume the expenses of repair.

If any defect attributable to TFT under this limited warranty cannot be reasonably cured by repair or replacement, TFT may elect to refund the purchase price of the equipment, less reasonable depreciation, in complete discharge of its obligations under this limited warranty. If TFT makes this election, claimant shall return the equipment to TFT free and clear of any liens and encumbrances.

This is a limited warranty. The original purchaser of the equipment, any person to whom it is transferred, and any person who is an intended or unintended beneficiary of the equipment, shall not be entitled to recover from TFT any consequential or incidental damages for injury to person and/or property resulting from any defective equipment manufactured or assembled by TFT. It is agreed and understood that the price stated for the equipment is in part consideration for limiting TFT's liability. Some states do not allow the exclusion or limitation of incidental or consequential damages, so the above may not apply to you.

TFT shall have no obligation under this limited warranty if the equipment is, or has been, misused or neglected (including failure to provide reasonable maintenance) or if there have been accidents to the equipment or if it has been repaired or altered by someone else.

**THIS IS A LIMITED EXPRESS WARRANTY ONLY. TFT EXPRESSLY DISCLAIMS WITH RESPECT TO THE EQUIPMENT ALL IMPLIED WARRANTIES OF MERCHANTABILITY AND ALL IMPLIED WARRANTIES OF FITNESS FOR A PARTICULAR PURPOSE. THERE IS NO WARRANTY OF ANY NATURE MADE BY TFT BEYOND THAT STATED IN THE DOCUMENT.**

This limited warranty gives you specific legal rights, and you may also have other rights which vary from state to state.

**TASK FORCE TIPS, Inc.**  
MADE IN USA • [www.tft.com](http://www.tft.com)

2800 E Evans Ave, Valparaiso, IN 46383-6940 USA  
800-348-2686 • 219-462-6161 • Fax 219-464-7155

## YE-REMAUX Remote Auxiliary Interface Box

The Remote Auxiliary Interface Box allows a user to utilize the AUX1 and AUX2 buttons located on the monitor operator station or any remote operator station. The Interface Box is equipped with two relays that can operate lights, interface to a valve controller or in some cases operate a valve directly, etc. The contact rating of the relay is 16 amps @ 30VDC for resistive loads and 8 amps @ 30VDC for inductive loads.

The installer will need to mount the interface box and connect the cable to power and the communication link of the monitor.



**The Interface Box provides no overload protection for the device it is controlling. Failure to provide overload protection will damage relay contacts, which will disable device being controlled.**

### 1.0 ENCLOSURE MOUNTING

Select proper enclosure location. Enclosure is designed to be surface mounted and the size is 5" x 3 1/8" (127 x 80mm). Height of enclosure is 2 3/8" (60mm). Refer to Figure 1.0.1 for mounting hole dimensions.

MOUNT ENCLOSURE  
WITH (2) 1/4-20 FASTENERS  
TIGHTEN SECURELY.

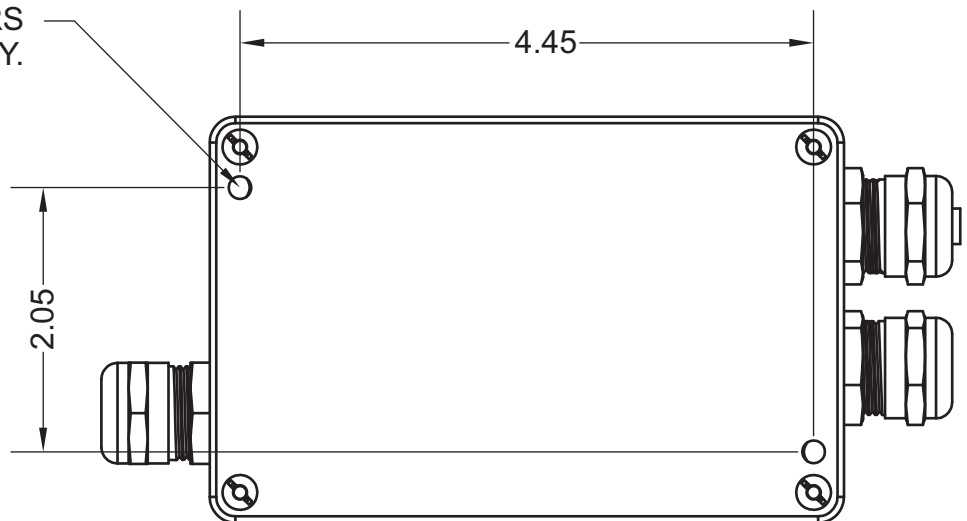

Figure 1.0.1  
Hole Dimensions

### 1.1 ELECTRICAL WIRING

The interface box needs to be connected to +12/24VDC (red) and ground (black). The blue & white wires from the interface box cable need to be connected to the blue & white wires from the monitor. A terminal box or a high quality, protected splice can be used to make these connections. See section 5.0 of installation manuals for further wiring information.

Each relay has one Form-C contact (common, normally open, normally closed) that can be used.

## 2.0 CONFIGURATION

The two relays on the circuit board can be individually configured as AUX1 or AUX2. Also the actuation of each relay can be configured to be momentary or latched. See Figure 2.0.1 for relay configuration DIP switch settings.

1. Remove lid from interface box.
2. Locate DIP switches on board and select configuration.
3. Replace lid. Verify rubber seal is clean and undamaged. Verify that no wires are caught between lid and box.

CHOOSE ONE CONFIGURATION  
FOR EACH RELAY

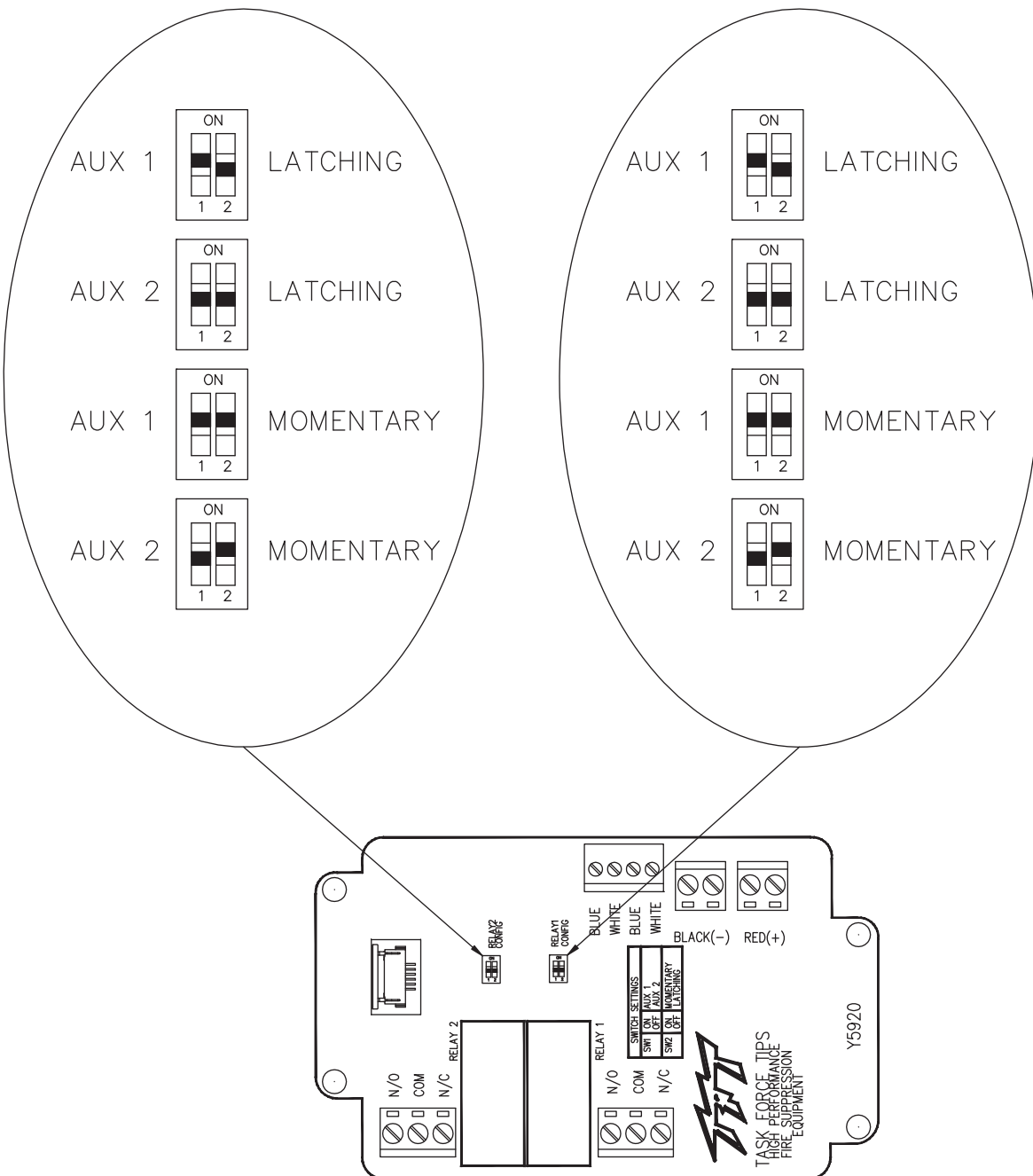

Figure 2.0.1  
Relay Configuration

**TASK FORCE TIPS, Inc.**  
MADE IN USA • [www.tft.com](http://www.tft.com)

2800 E. Evans Ave, Valparaiso, IN 46383-6940 USA  
800-348-2686 • 219-462-6161 • Fax 219-464-7155



## Y4E-COMM Communication Interface Box with AT STOW Relay

The new style Communication Interface Box provides feedback for the user that the monitor is in the AT STOWED position. The Interface Box contains a circuit board that is equipped with a relay that is energized when the monitor is in use and de-energized when the monitor reaches its final STOW location. The contact rating of the relay is 1 amp @ 30VDC for resistive loads and 0.2 amps @ 30VDC for inductive loads.

### 1.0 ENCLOSURE MOUNTING

See section 5.7.1 of installation manual for mounting.

### 1.1 ELECTRICAL WIRING

See section 5.7.2 of installation manual for wiring information regarding power and communication wires.

The AT STOW relay has one Form-C contact (common, normally open, normally closed) that can be used. The figure below shows the terminal blocks available for user wiring.

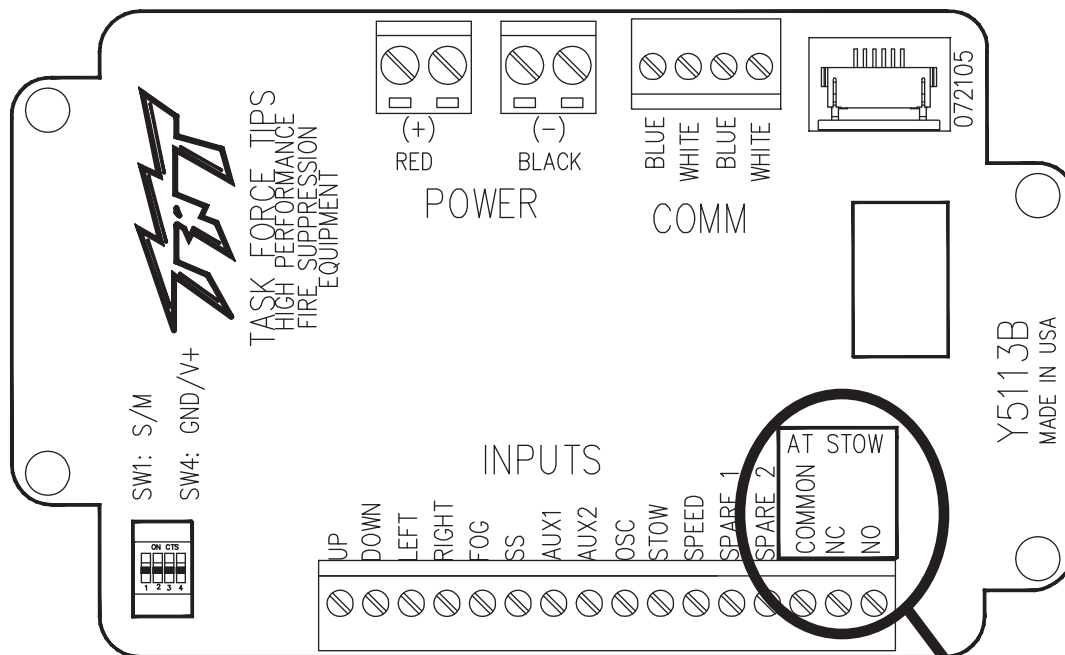

Figure 1.1.1  
Relay / Terminal Location

**AT STOW RELAY  
USER TERMINALS**



## Addendum RC Monitor Installation Manuals LIY-200, LIY-300, LIX-300

### YE-RF-900 Wireless Operator Station, 900 MHz

The Wireless Operator Station is radio linked to the monitor so that the operator can control the water discharge from the best vantage point. This operator station gives the user full control of the monitor including the STOW, OSCillate, and any AUXiliary functions. Every TFT RC monitor is shipped with the receiver and antenna pre-mounted in the monitor control box. All the user needs to do is mount the storage bracket and teach the ID code to the handheld unit.

The range of the wireless operator station is 500 ft (152 m) and the handheld unit is powered by four (4) AA batteries, lithium batteries are recommended. Lithium batteries will provide 33 hours of continuous operation. When the battery voltage falls below a set level, the POWER led will begin to flash. At this point there is ~3 hours of continuous operation remaining. Other battery types will significantly reduce operating time and unit reliability.

The handheld unit will automatically turn off after 5 minutes if no buttons are pressed.

#### 1.0 SPECIFICATIONS:

Handheld Unit Batteries	Four (AA) Batteries, Lithium Recommended	
Transmitting Power	100mW	
Operating Range	500 ft (152m)	
Operating Frequency	900 MHz (902-928 MHz)	
Agency Approvals	FCC Part 15.247 Industry Canada (IC) Europe	OUR9XSTREAM 4214A-9XSTREAM N/A

#### 1.1 TEACHING ID CODE:

Every monitor has a unique ID code that must be “taught or transferred” to the handheld unit. This unique ID code allows multiple monitors to be used in one location without interference. Perform the following procedure to teach the handheld unit.

##### On Handheld Unit:

- Press POWER button to turn on electronics.
- Press and hold both LEFT & RIGHT buttons for 5 seconds.
- Continue to press LEFT & RIGHT buttons and then press UP button for 2 seconds.
- Release buttons. OSC & STOW leds will flash rapidly to indicate that the unit is in teach mode.

##### On Monitor Control Box:

- Apply power to monitor.
  - Press and hold both LEFT & RIGHT buttons for 5 seconds.
  - Continue to press LEFT & RIGHT buttons and then press UP button for 2 seconds.
  - Release buttons. OSC & STOW leds will flash rapidly to indicate that the unit is in teach mode.
- OSC & STOW leds on handheld unit will stop flashing after ID code is transferred.
- Press DOWN button on monitor control box to exit teach mode.
- Cycle power off and back on to monitor.

## 1.2 OPERATION:

- Press POWER button to turn on electronics.
- Use operator station just like any other wired operator station.
- Press POWER button again to turn off electronics or after 5 minutes of idle operation, handheld unit will automatically turn off.

**NOTE!!!** If after pressing a button, the OSC & STOW leds alternately flash, this indicates no communication link is present with the monitor. The handheld unit is out of range or cannot establish a link with the monitor. Move to a different location and then retry, also verify monitor has power applied.

## 1.3 CHANGING BATTERIES:

- Remove two (2) screws on backside of handheld unit and slide bottom half of rubber bumper off enclosure.
- Replace batteries verifying that polarity is correct.
- Replace rubber bumper and retaining screws.

**CAUTION** Properly dispose of old batteries. Do not puncture, incinerate, or disassemble batteries. Do not mix battery types.

## 2.0 MOUNTING STORAGE BRACKET

Select proper location for mounting storage bracket. Panel spare required will be 6.0" x 11.2" (152 x 285mm). Refer to Figure 2.0 for hole dimensions. Bracket can be used as a template. **Be sure spring is in position.**

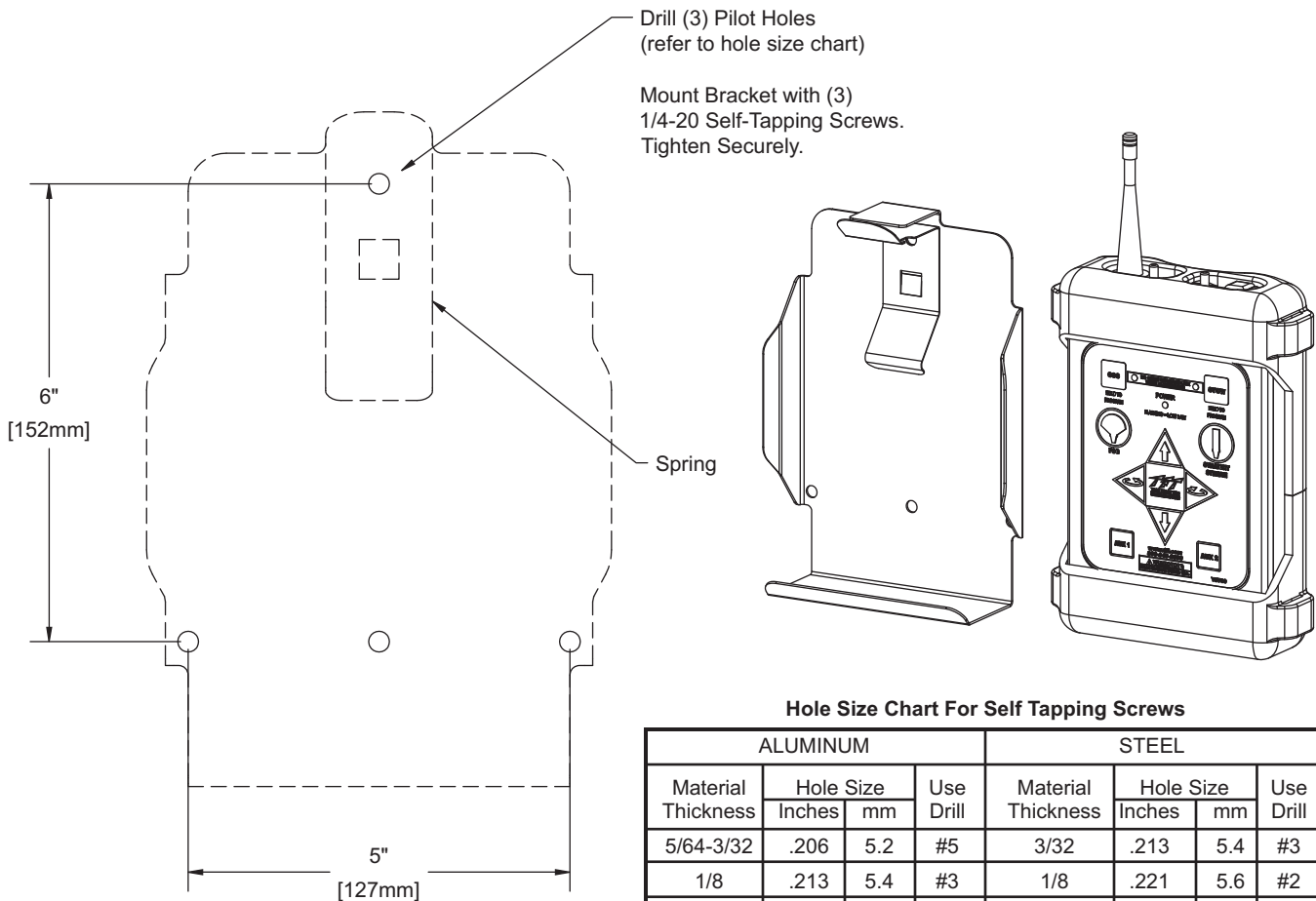

Fig 2.0 Wireless Operator Station  
Storage Bracket Hole Dimensions

Hole Size Chart For Self Tapping Screws

ALUMINUM				STEEL			
Material Thickness	Hole Size		Use Drill	Material Thickness	Hole Size		Use Drill
	Inches	mm			Inches	mm	
5/64-3/32	.206	5.2	#5	3/32	.213	5.4	#3
1/8	.213	5.4	#3	1/8	.221	5.6	#2
3/16	.221	5.6	#2	3/16	.228	5.8	#1

**TASK FORCE TIPS, Inc.**  
MADE IN USA • www.tft.com

2800 E. Evans Ave, Valparaiso, IN 46383-6940 USA  
800-348-2686 • 219-462-6161 • Fax 219-464-7155