



MANUAL: TORNADO, TORNADO OSC & TORNADO RC MONITOR

INSTRUCTIONS FOR INSTALLATION, SAFE OPERATION AND MAINTENANCE

⚠ DANGER

Understand manual before use. Operation of this device without understanding the manual and receiving proper training is a misuse of this equipment.
Obtain safety information at www.tft.com/serial-number

This instruction manual is intended to familiarize firefighters and maintenance personnel with the operation, servicing and safety procedures associated with the Tornado Monitor series.

This manual should be kept available to all operating and maintenance personnel.

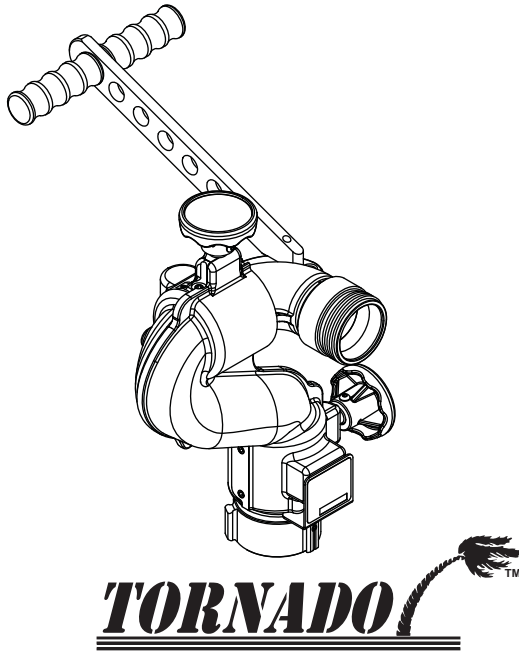

See Section 3.2.3 for
Flow/Pressure
Operating Envelope

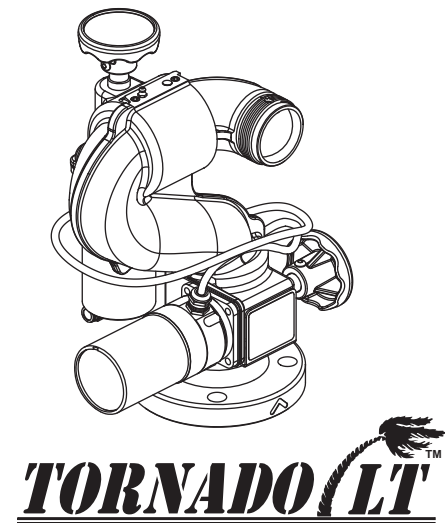
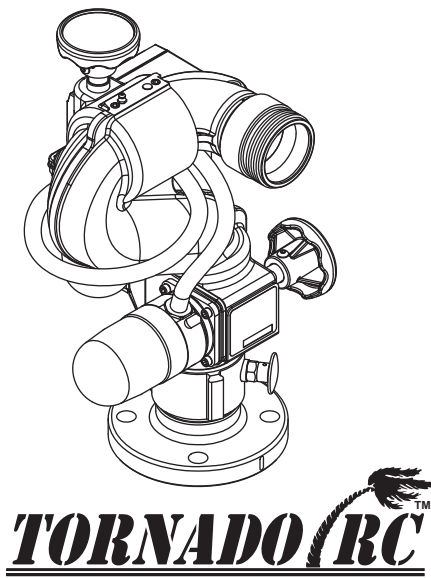
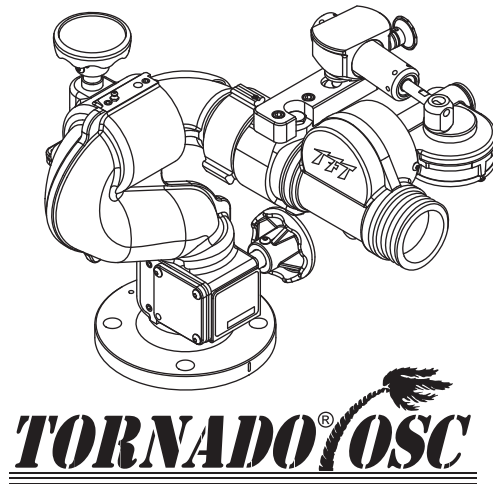

TASK FORCE TIPS LLC
MADE IN USA • tft.com

3701 Innovation Way, Valparaiso, IN 46383-9327 USA
800-348-2686 • 219-462-6161 • Fax 219-464-7155

DANGER

PERSONAL RESPONSIBILITY CODE

The member companies of FEMSA that provide emergency response equipment and services want responders to know and understand the following:

1. Firefighting and Emergency Response are inherently dangerous activities requiring proper training in their hazards and the use of extreme caution at all times.
2. It is your responsibility to read and understand any user's instructions, including purpose and limitations, provided with any piece of equipment you may be called upon to use.
3. It is your responsibility to know that you have been properly trained in Firefighting and /or Emergency Response and in the use, precautions, and care of any equipment you may be called upon to use.
4. It is your responsibility to be in proper physical condition and to maintain the personal skill level required to operate any equipment you may be called upon to use.
5. It is your responsibility to know that your equipment is in operable condition and has been maintained in accordance with the manufacturer's instructions.
6. Failure to follow these guidelines may result in death, burns or other severe injury.



Fire and Emergency Manufacturers and Service Association
P.O. Box 147, Lynnfield, MA 01940 • www.FEMSA.org

Table Of Contents

- 1.0 Meaning of Safety Signal Words
- 2.0 Safety
- 3.0 General Information
 - 3.1 Various Models and Terms
 - 3.2 Specifications
 - 3.2.1 Mechanical
 - 3.2.2 Electrical
 - 3.2.3 Safe Operating Envelope
 - 3.3 Use With Salt Water
 - 3.4 Inlets and Outlets
 - 3.5 Overall Dimensions
- 4.0 Installation
 - 4.1 Structural Requirements
 - 4.2 Quick Connect Inlet Mounting and Travel Ranges
 - 4.2.1 Travel Stops
 - 4.3 Nozzle Installation
 - 4.4 Pressure Gage
 - 4.5 Handle Installation
 - 4.6 Draining Residual Water
- 5.0 Operation of Tiller Monitor
 - 5.1 Spray Trajectory Adjustment
- 6.0 Operation of Oscillating Monitor
 - 6.1 Horizontal Rotation Control
 - 6.2 Elevation Control
 - 6.3 To Engage the Oscillating Mechanism
 - 6.4 To Disengage the Oscillating Mechanism
 - 6.5 Coverage Area of Oscillating Monitor
- 7.0 Operation of RC Monitors
- 8.0 Recommended Park Position
 - 8.1 Override Knobs
- 9.0 Flow Characteristics
 - 9.1 Stacked Tips Flow
 - 9.2 Tornado Monitor and Stream Straightener Friction Loss
 - 9.3 Stream Straighteners
 - 9.3.1 Stream Straighteners with Stacked Tips
 - 9.3.2 Stream Straighteners with Fog Nozzles
- 10.0 Drawings and Parts List
 - 10.1 Manual Monitor
 - 10.2 Tornado OSC
 - 10.3 Oscillator
 - 10.4 RC Monitor
 - 10.5 Monitor Control Box
 - 10.6 Motor Subassembly
 - 10.7 RC LT Monitor
 - 10.8 Junction Box
- 11.0 Warranty
- 12.0 Maintenance
 - 12.1 Lubrication
 - 12.2 Troubleshooting
 - 12.3 Repair
- 13.0 Answers to Your Questions
- 14.0 Inspection Checklist.....Back Cover

1.0 MEANING OF SAFETY SIGNAL WORDS

A safety related message is identified by a safety alert symbol and a signal word to indicate the level of risk involved with a particular hazard. Per ANSI standard Z535-2011, the definitions of the four signal words are as follows:

⚠ DANGER

DANGER indicates a hazardous situation which, if not avoided, will result in death or serious injury.

⚠ WARNING

WARNING indicates a hazardous situation which, if not avoided, could result in death or serious injury.

⚠ CAUTION

CAUTION indicates a potentially hazardous situation which, if not avoided, could result in minor or moderate injury.

NOTICE

NOTICE is used to address practices not related to physical injury.

2.0 SAFETY

The operation of this monitor can be dangerous. The following must be observed at all times.

⚠ WARNING

An inadequate supply of nozzle pressure and/or flow will cause an ineffective stream and can result in injury, death, or loss of property. See flow graphs or call 800-348-2686 for assistance.

⚠ WARNING

Injury or death may occur by attempting to use a damaged monitor. Before using the monitor inspect it for damage resulting from, but not limited to:

- Failure to drain monitor followed by exposure to freezing conditions.
See section DRAINING RESIDUAL WATER for instructions.
- Exposure of monitor to temperatures in excess of 160 degrees F.
- Missing parts, physical abuse, exposure to severe chemicals.
- Deformed or cracked flanges damaged as a result of improper installation.
 - Excessive bolt torque
 - Wrong tightening sequence

⚠ WARNING

Injury can result from an inadequately supported monitor. The monitor mount must be capable of supporting 400 lbs (180 kg) of nozzle reaction force.

⚠ WARNING

The stream exiting a monitor is very powerful and capable of causing injury and property damage. Make sure the monitor is securely attached to the base and pointing in a safe direction before water to the monitor is turned on. Use care in directing the stream.

⚠ WARNING

The monitor may be damaged if frozen while containing sufficient amounts of water. Such damage may be difficult to detect visually and can lead to possible injury or death. Any time the monitor is subject to possible damage from freezing, it must be hydrostatically tested by qualified personnel before being considered safe for use.

⚠ WARNING

Do not attempt to modify the oscillating mechanism to fit any other monitor. To do so will cause the reaction force of the nozzle to be misaligned with the center of rotation. The monitor may spin very fast and could cause injury or death.

⚠ WARNING

Keep hands and fingers away from moving parts of the oscillating unit when water is flowing. There are moving parts that can pinch fingers and hands.

⚠ WARNING

This equipment is intended for use by trained personnel for firefighting. Their use for other purposes may involve hazards not addressed by this manual. Seek appropriate guidance and training to reduce risk of injury.

⚠ CAUTION

The electric monitor may be remotely operated. The electric drives are current limited but may still produce enough force to cause injury. Keep hands and fingers away from pinch points on the monitor.

⚠ CAUTION

Do not use the manual override knobs while the electric controls are in operation. The electric drives produce enough torque to cause injury.

⚠ CAUTION

Maximum flow and pressure is 500 gpm (1900 l/min) and 200 psi (14 bar). Damage or injury may result if the monitor is operated beyond these limits.

⚠ CAUTION

On many vehicle installations, the monitor is the highest point on the apparatus. Be sure there is sufficient clearance to safely pass under any doors or overhead obstructions. Always check parked position of the monitor before moving.

NOTICE

To prevent mechanical damage, do not drop or throw equipment.

3.0 GENERAL INFORMATION

The Tornado monitor is a 2 1/4 inch waterway, 500 gpm maximum monitor. It is available in a manually operated model as well as an electric remote or joystick controlled model, and hydraulically oscillating version. The electric remote model is known as the Tornado RC, the joystick model is known as the Tornado LT, and the hydraulically oscillating version is known as the Tornado OSC.

3.1 VARIOUS MODELS AND TERMS

The Tornado monitor is available in several different models and inlet connections. Basic body styles are shown below, along with some various parts and controls.

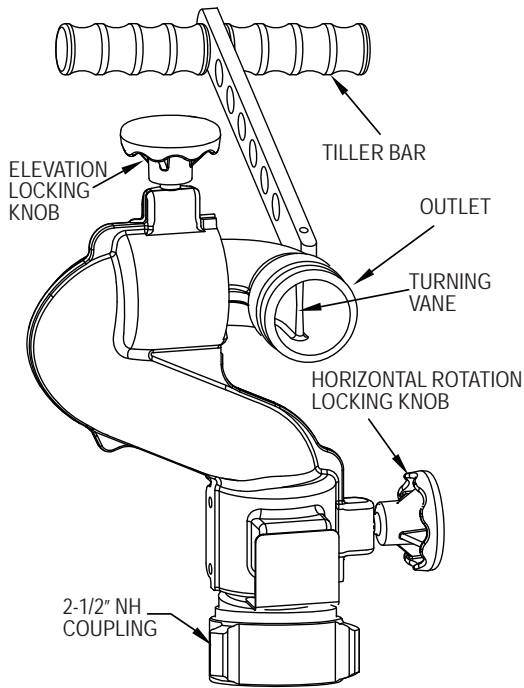

Fig. 3.1A

Manual Tornado Monitor Part Identification

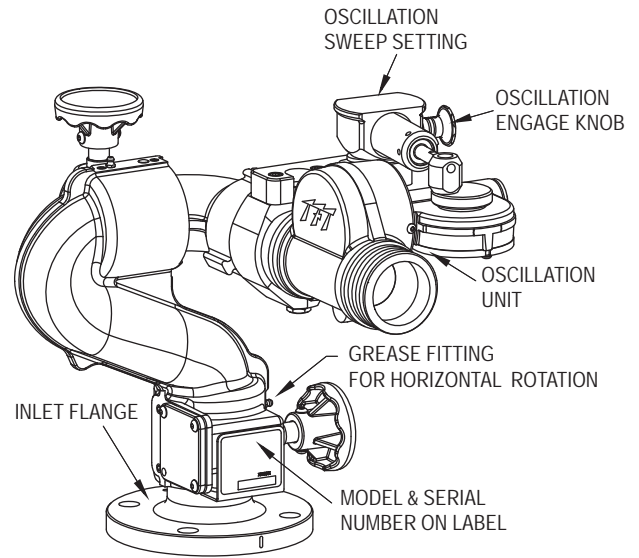

Fig. 3.1B

Tornado OSC Monitor Part Identification

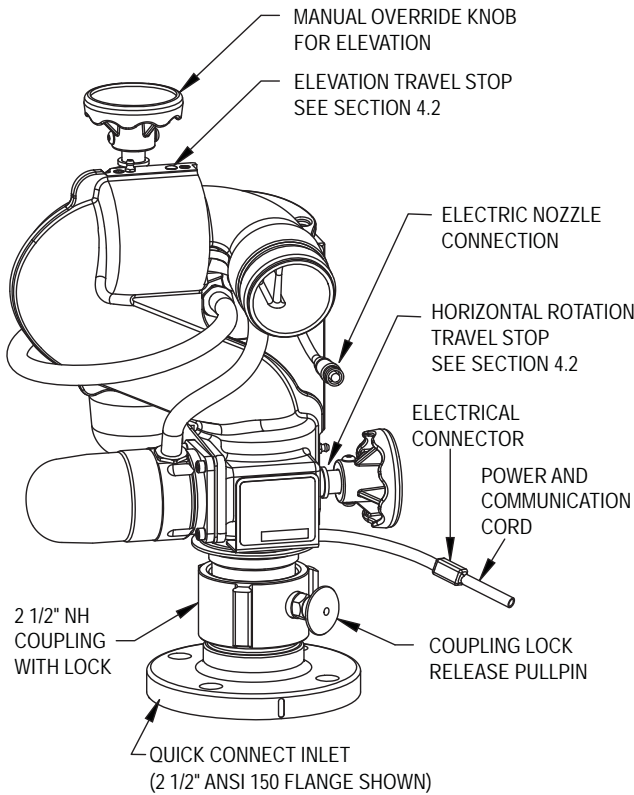

Fig. 3.1C

Tornado RC Monitor Part Identification

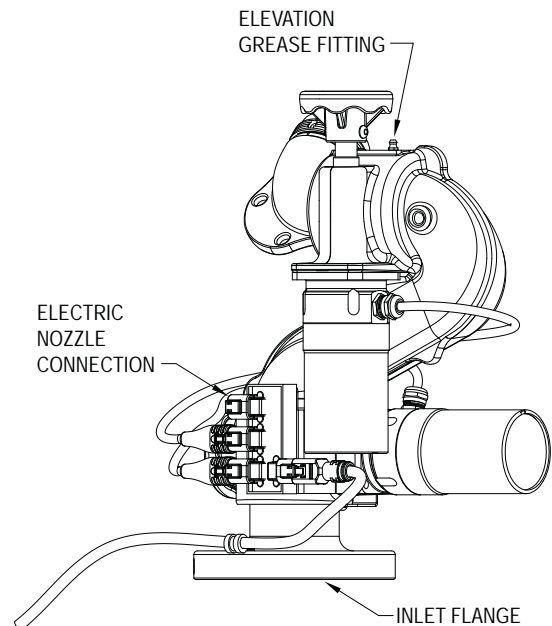

Fig 3.1D

Tornado LT Monitor Part Identification

3.2 SPECIFICATIONS

3.2.1 MECHANICAL

	Manual		Electric		OSC	
	US	METRIC	US	METRIC	US	METRIC
Weight	12 lbs	5.5 kg	25 lbs	11.4 kg	27 lbs	12.2 kg
Min. Flow Area	8.3 in ²	24.5 cm ²	8.3 in ²	24.5 cm ²	8.3 in ²	24.5 cm ²
Max Flow	500 gpm	1900 l/min	500 gpm	1900 l/min	500 gpm	1900 l/min
Max Operating Pressure	200 psi	14 bar	200 psi	14 bar	200 psi	14 bar
Horizontal Travel Range	360° Continuous		370° (185° left and right)		360° Continuous	
Standard Inlets	2.5"-7.5 NH Female 2.0"-11 BSP Female 2.0"-11.5 NPT Female 3.0"-8 NPT Female 2.5"-11 BSP Female 2.5" ANSI 150 Flange 3.0 ANSI 150 Flange 2.5"-8 NPT Female TFT Code-RLF (fits Extend-A-Gun RC3)				2.5 ANSI 150 Flange 3.0 ANSI 150 Flange 4.0 ANSI 150/DN100PN 16	
Standard Outlets	2.5"-7.5 NH Male 2.5"-11 BSP Male 1.5"-9 NH Male 2.5" Special Male				2.5"-7.5 NH Male 2.5"-11 BSP Male 2.5"-8 NPSH Male 2.5" Special Male	
Materials Used	ANSI A356.0-T6 Aluminum, Stainless, Nylon					
Maximum Torque Elevation			35 ft•lbs	50 n•m		
Maximum Torque Horizontal			35 ft•lbs	50 n•m		
Speed Elevation			25 deg/sec			
Speed Horizontal			25 deg/sec			

3.2.2 ELECTRICAL

Further specifications for Tornado RC models are shown the Remote Control (RC) Monitor Electrical Controls Supplemental Instructions (LIY-500).

3.2.3 SAFE OPERATING ENVELOPE

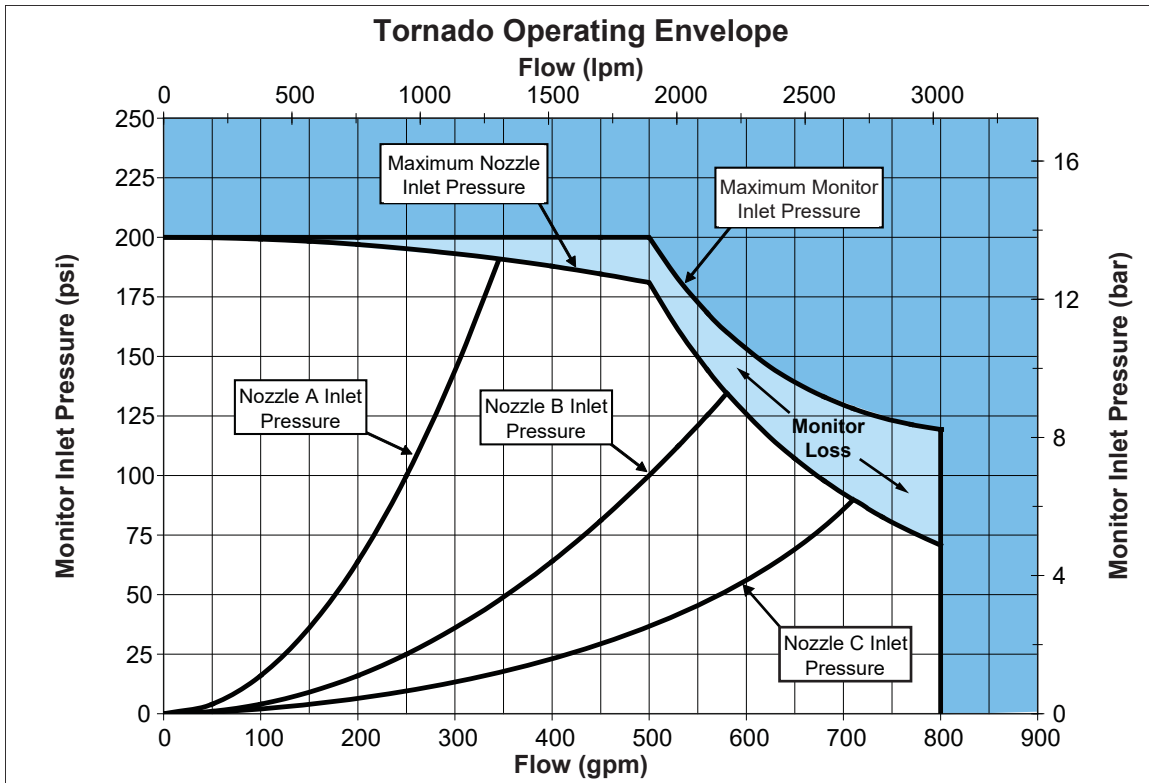

Nozzle A flows 250 gpm (950 l/min) at 100 psi (7 bar), K factor = 25
 Nozzle B flows 500 gpm (1900 l/min) at 100 psi (7 bar), K factor = 50
 Nozzle C flows 750 gpm (2900 l/min) at 100 psi (7 bar), K factor = 75

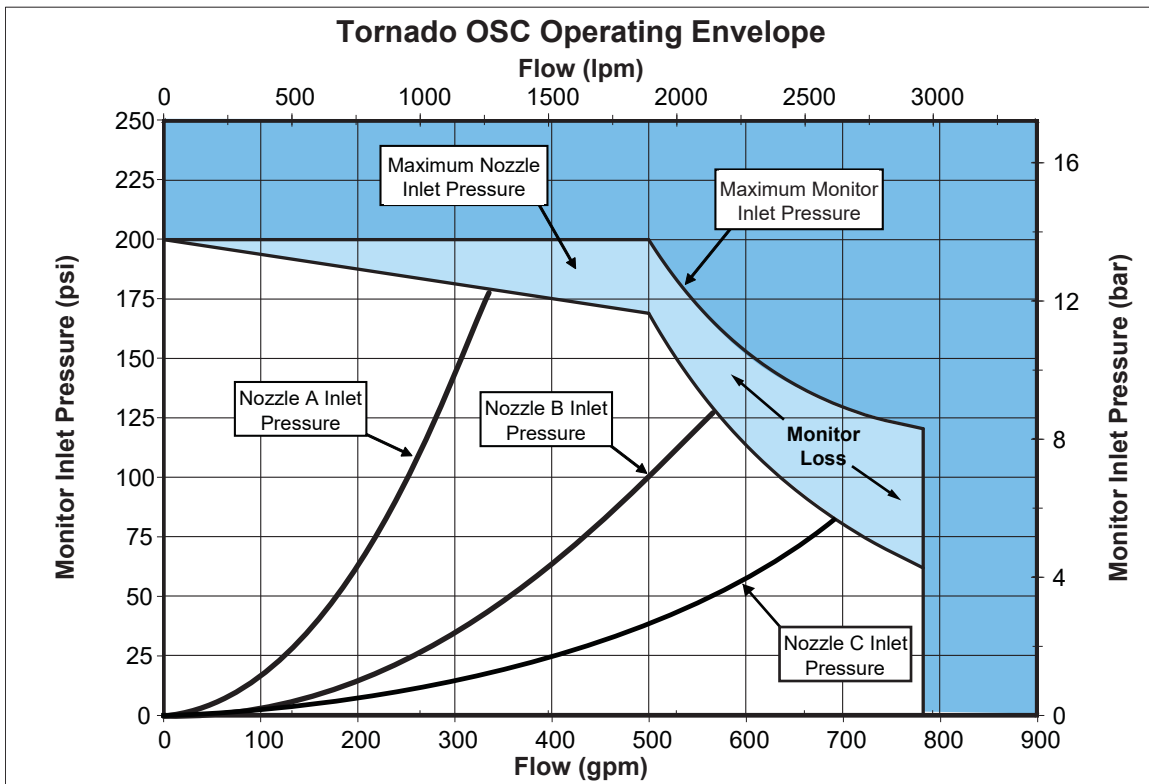

Nozzle A flows 250 gpm (950 l/min) at 100 psi (7 bar), K factor = 25
 Nozzle B flows 500 gpm (1900 l/min) at 100 psi (7 bar), K factor = 50
 Nozzle C flows 750 gpm (2900 l/min) at 100 psi (7 bar), K factor = 75

3.3 USE WITH SALT WATER

Use with salt water is permissible provided the monitor is thoroughly cleaned with fresh water after each use. The service life of the monitor may be shortened due to the effects of corrosion and is not covered under warranty.

3.4 INLET AND OUTLET OPTIONS

Available inlets and outlets are shown below and should be specified at time of order.

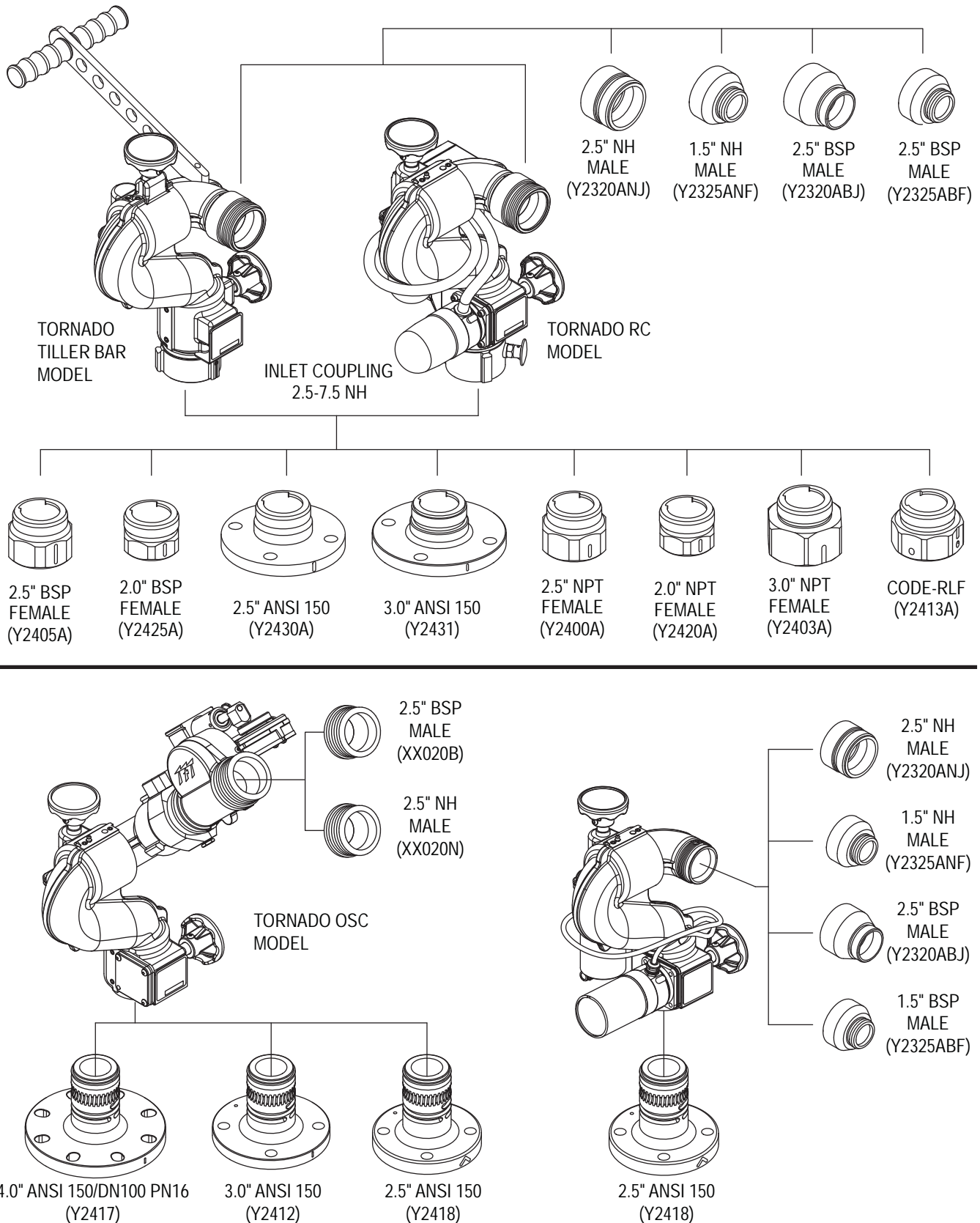
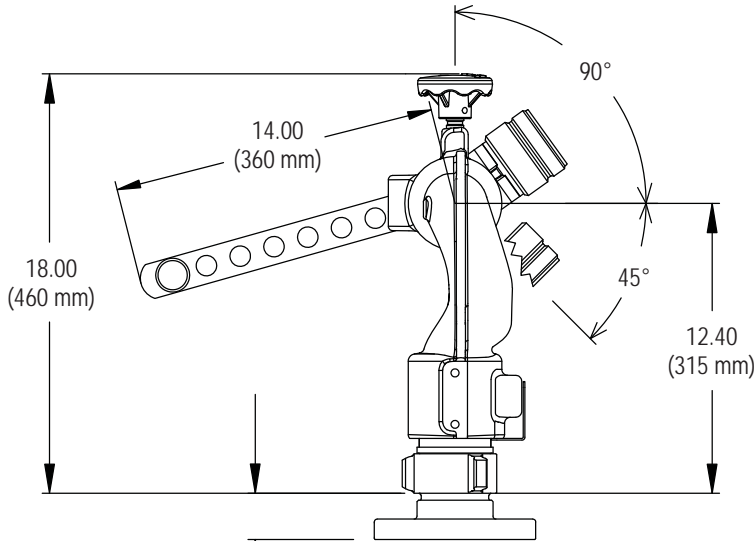
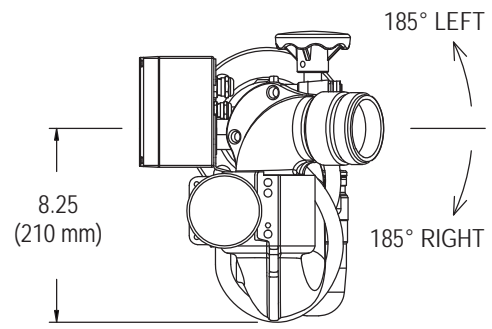
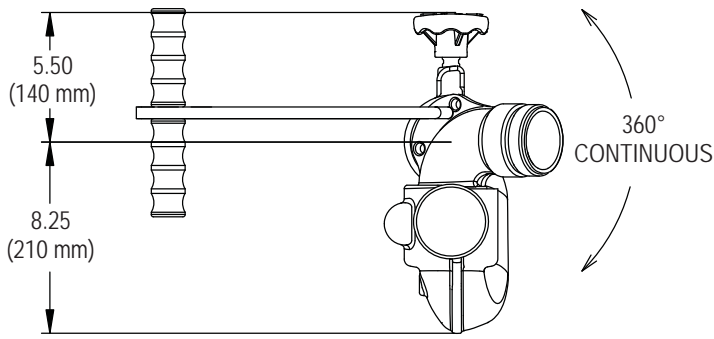

Fig 3.4
Inlets and Outlets

3.5 OVERALL DIMENSIONS



See table below for additional height from Inlet Fitting

Fig 3.5a
Manual Tornado Monitor Dimensions

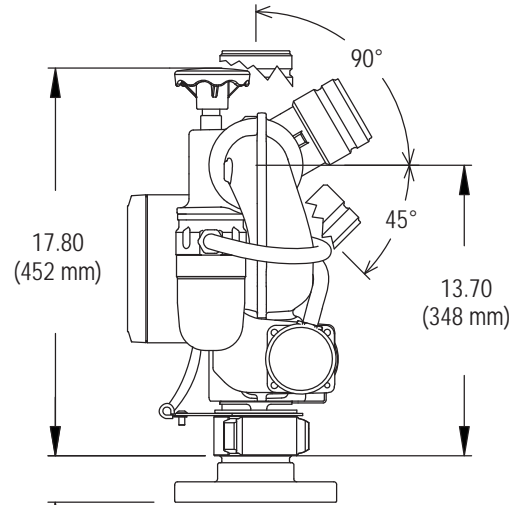

See table below for additional height from Inlet Fitting

Fig 3.5b
Electric Tornado RC Monitor Dimensions

MODEL	INLET FITTING TYPE	ADDITIONAL HEIGHT
Y2-*1*A	2-1/2" - 7.5 NH FEMALE (no inlet fitting)	0.00" 0 mm
Y2-*2*A	2-1/2" - 11 BSP FEMALE	2.00" 51 mm
Y2-*3*A	2.0" - 11.5 BSP FEMALE	1.50" 38 mm
Y2-*6*A	2.5" ANSI 150 FLANGE	2.00" 51 mm
Y2-*0*A	3.0" ANSI 150 FLANGE	2.10" 53 mm
Y2-*7*A	2-1/2" - 8 NPT FEMALE	2.00" 51 mm
Y2-*8*A	2.0" - 11.5 NPT FEMALE	1.50" 38 mm
Y2-*9*A	3.0" - 8 NPT FEMALE	2.44" 62 mm
Y2-*L*A	TFT CODE-RLF (fits Extend-A-Gun RC3)	2.00" 51 mm

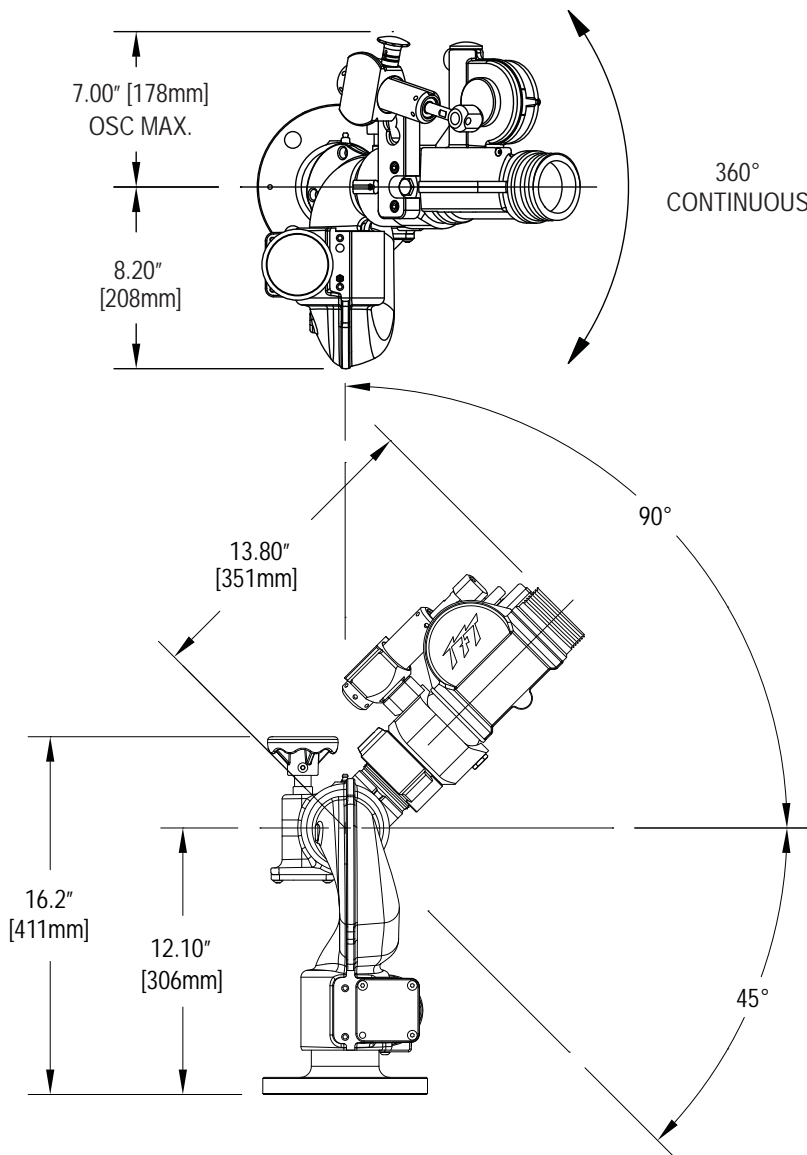

Fig 3.5c
Tornado OSC Monitor Dimensions

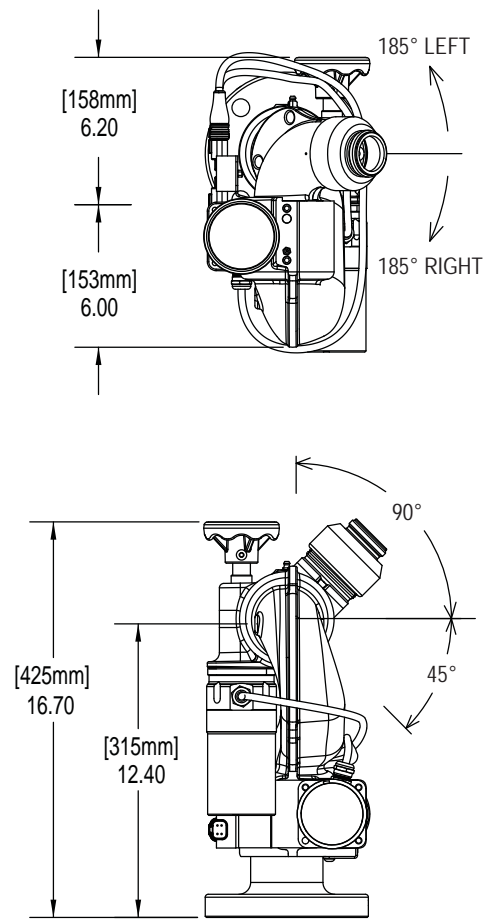

Fig 3.5d
Electric Tornado RC LT Monitor Dimensions

MODEL	INLET FITTING TYPE	ADDITIONAL HEIGHT
Y2-SD*a	2.5" ANSI 150 FLANGE	0.60" 15 mm
Y2-SF*A	3.0" ANSI 150 FLANGE	0.00" 0 mm
Y2-SG*A	4.0" ANSI 150 FLANGE DN100 PN16	0.16" 4 mm

4.0 INSTALLATION

See Remote Control (RC) Monitor Electrical Controls Supplemental Instructions (LIY-500) For Tornado RC models.

4.1 STRUCTURAL REQUIREMENTS

The structure that the Tornado Monitor is mounted to must withstand the internal pressure of the monitor as well as shear and bending forces due to nozzle reaction. Nozzle reaction can be as high as 400 lbs (180 kg) (500 gpm at 200 psi).

For flanged connections the use of flat flanges without raised faces is recommended. Use a ring gasket as defined in ASME 16.21 or ISO 7483. Tighten flange bolts in an alternating sequence as shown in figure 4.1A. Tighten sequentially each bolt or stud three times with 30%, then 60%, and finally 100% of the specified torque in figure 4.1B. Tighten to 76-80 ft-lb (100-110 Newton-Meters).

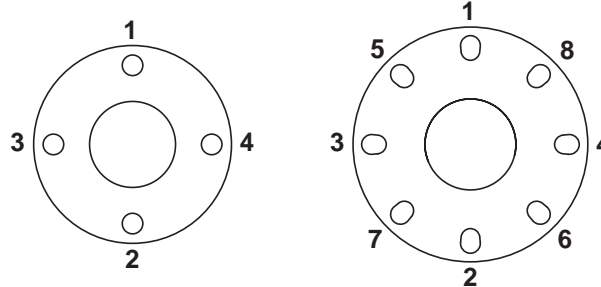

Tighten Sequentially Each Bolt Three Times

Fig 4.1A Flange Bolt Tightening Sequence

FLANGE TYPE	OUTSIDE DIAMETER		THICKNESS		BOLT HOLE CIRCLE		# OF BOLTS	SIZE OF BOLTS		TORQUE ON BOLTS	
	in	mm	in	mm	in	mm		in	mm	ft-lb	N-m
2.5 ANSI 150	6.9	175	0.98	25	5.5	140	4	5/8	16	76-80	100-110
3" ANSI 125/150-DN80 PN20	7.5	190	0.75	20	6.0	152.5	4	5/8	16	76-80	100-110
4" ANSI 150-DN100 PN20	9.0	230	0.94	23	7.5	190	8	5/8	16	76-80	100-110
DN80, PN16 FLANGE	7.9	200	0.87	22	6.3	160	8	5/8	16	76-80	100-110
DN100, PN16 FLANGE	8.7	220	0.87	22	7.1	180	8	5/8	16	76-80	100-110

⚠ WARNING

Injury can result from an inadequately supported monitor. The monitor mount must be capable of supporting the nozzle reaction force which can be as high as 400 lbs (180 kg). Flanges and pipe made from plastic are inadequate for monitor mounting and must not be used. This monitor is not recommended for portable use.

4.2 QUICK CONNECT INLET MOUNTING AND TRAVEL RANGES

The Tornado Monitor is available with various inlet fittings. These Inlet Adaptors must be oriented upon installation so the Tornado will point in the desired direction. Figure 4.2A shows examples of Inlet Adaptors and the location of a "Straight Ahead Reference Mark". This figure also gives some information about securing the Tornado to the Inlet Adapter. Travel ranges relative to the Straight Ahead Reference Mark are shown in Figure 4.2B. Figure 4.2C gives the location of the "Stop Bolts", which are used to limit the travel.

A rotational lock is included on quick connect couplings on RC models. The locking pin also holds the coupling up and out of the way while orienting the monitor to engage the internal ear into the slot on the adaptor. Hold the pin out, push the coupling up and the release pin before installing monitor on the adaptor. Once the monitor is properly aligned on the adaptor, hold the pin out while sliding the coupling down to the adaptor. Rotate the coupling until it is tight. The coupling may become sufficiently tight before reaching the next detent position. It is not necessary to over tighten the coupling if the pull pin is between detent positions. Do not use the pull pin as a lever to tighten or loosen the coupling.

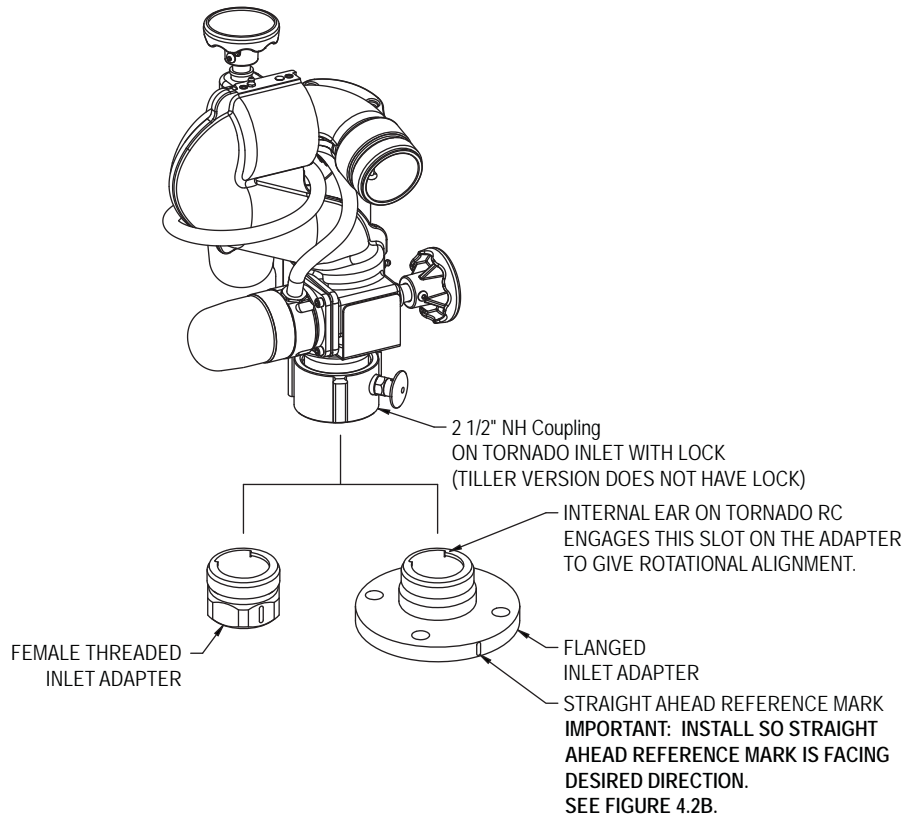

Fig 4.2A
Inlet Adapter and Straight Ahead Reference Mark

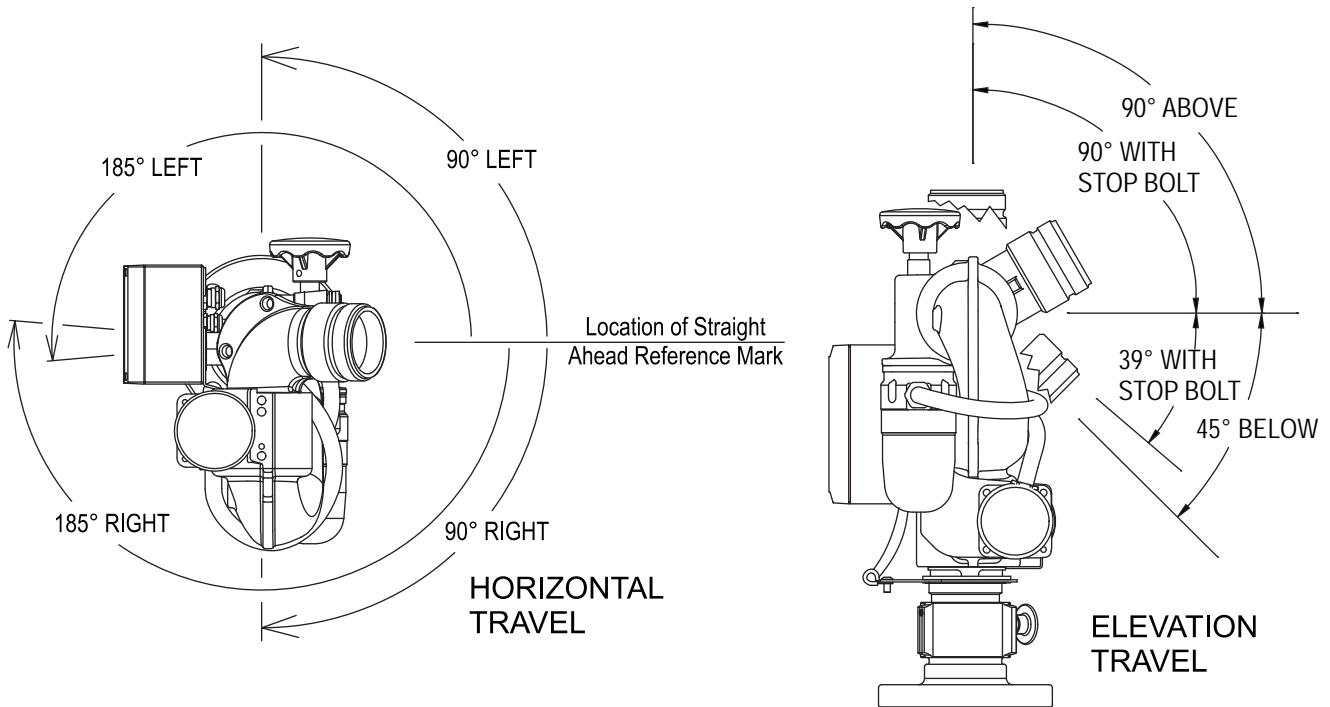

Fig 4.2B Travel Ranges Relative to
Straight Ahead Reference Mark

4.2.1 TRAVEL STOPS

Stop bolts and adjustment disks can be installed to limit the travel of the monitor in either travel direction. Instructions on how to install the stop bolts and adjustment disks are shown below.

Remove Set Screw And Install Stop Bolt To Obtain Desired Travel Limits.

RC Model With No Stop Bolts Installed Has 185° Left And Right Travel Limits.

Tiller Model Has Continuous 360° Horizontal Rotation. Stop Bolts Are Not Used On Tiller Model.

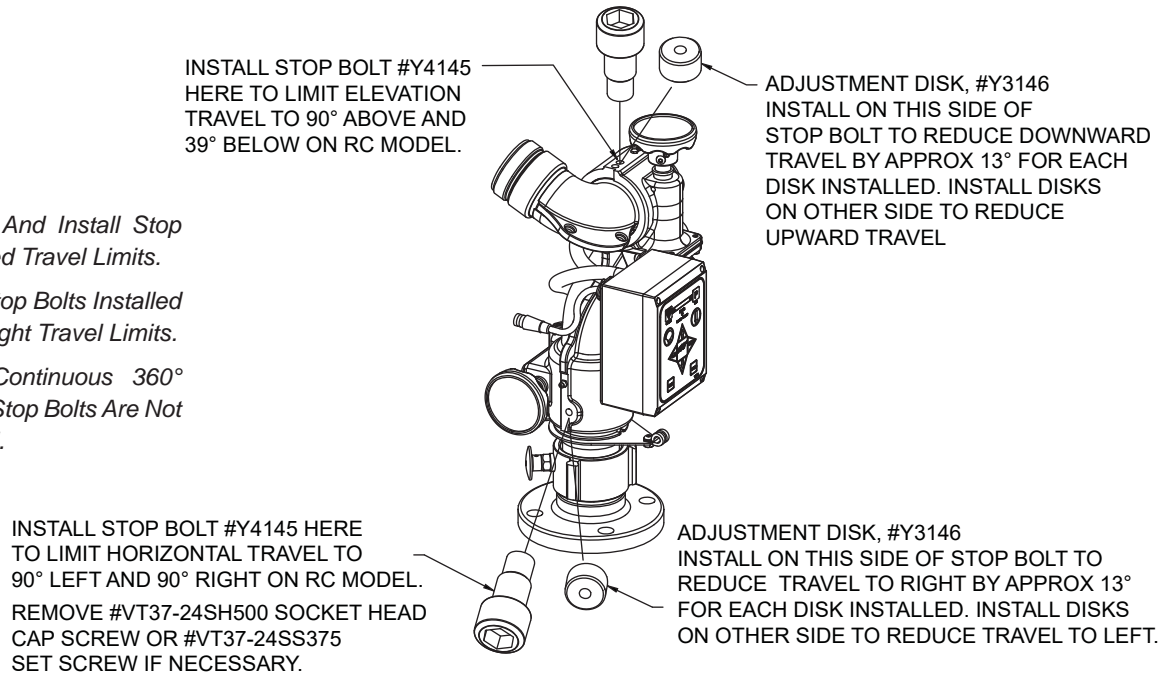

Fig 4.2.1 Stop Bolt Use

4.3 NOZZLE INSTALLATION

The nozzle is simply screwed onto the monitor's exit threads. If the nozzle is installed on a Tornado RC (with electric motors) assure that the nozzle's coupling does not make contact with the horizontal drive motor housing and actuator when the monitor is in its lowest elevation position.

CAUTION The nozzle threads must match the threads of the Tornado monitor in both size and type. Mismatched or damaged threads may cause the nozzle to leak or uncouple under pressure and could cause injury.

CAUTION Do not connect aluminum to brass or brass to aluminum. Dissimilar metals coupled together can cause galvanic corrosion that will freeze the threaded joint or cause complete loss of thread engagement. If dissimilar metals must be coupled together, the effects of corrosion can be greatly delayed by various coatings on the metal such as powder paint, hard anodizing, or silicone grease.

4.4 PRESSURE GAGE PORT

There is a ¼" NPT female threaded hole on the back of the monitor and the exit elbow. The holes are plugged from the factory. If a pressure gage is desired, unscrew the plug and install the gage using pipe sealant. Make sure the gage does not interfere with operation.

4.5 HANDLE INSTALLATION

The tiller handle is shipped loose from the monitor and must be installed to complete the installation process. When installing the tiller handle, be sure to coat the threads of the mounting screw with the Loctite supplied in the hardware packet.

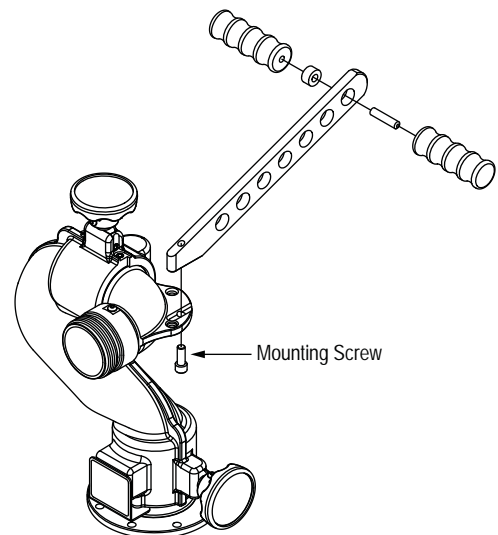

Fig 4.5 Tiller Handle Installation

4.6 DRAINING RESIDUAL WATER

There is no drain on the Tornado Monitor itself. A drain valve should be installed on the piping to which the monitor is attached.

WARNING

All monitors, valves and standpipes exposed to freezing conditions must be drained immediately following use to prevent damage. To drain a standpipe, a drainage port must be opened underground below the frost depth to keep water out of the standpipe until the next use.

5.0 OPERATION OF TILLER MONITORS

5.1 SPRAY TRAJECTORY ADJUSTMENT

On the Tiller Bar model the horizontal rotation is changed by pushing or pulling horizontally on the Tiller Handle. Twisting the Rotation Locking Knob clockwise will increase the drag on the swivel joint to “lock” the monitor in a particular direction.

CAUTION

Injury can result from the monitor changing direction due to an off center nozzle reaction. An off center nozzle reaction may be caused by debris in the nozzle causing an asymmetrical stream. Always keep the rotation lock tight when not rotating the monitor. Always keep one hand on the tiller handle when loosening the locking knob. Where continuous 360 degree rotation of the monitor is not needed it is recommended that the Horizontal Rotation Stop Bolts be installed to reduce any chance of the monitor spinning due to an off center nozzle reaction caused by debris trapped in the nozzle.

6.0 OPERATION OF OSCILLATING MONITORS

6.1 HORIZONTAL ROTATION CONTROL

A handwheel controls the monitor's horizontal rotation direction. Clockwise rotation of the handwheel moves the nozzle to the left and counter-clockwise rotation to the right. Approximately 8.5 turns of the handwheel will give a 90 degree change in horizontal rotation direction.

6.2 ELEVATION CONTROL

A handwheel controls the monitor's elevation direction. Clockwise rotation of the handwheel raises the elevation and counterclockwise lowers it. About 13 turns of the handwheel will give the complete 135 degree elevation travel range of the monitor.

WARNING

Do not attempt to modify the oscillating mechanism to fit any other monitor. To do so will cause the reaction force of the nozzle to be misaligned with the center of rotation. The monitor may spin very fast and could cause injury or death.

6.3 TO ENGAGE THE OSCILLATING MECHANISM

If the nozzle moves freely left to right by hand, the oscillating mechanism is not engaged. To engage, ensure the black knob on the side of the oscillator is released, and move the nozzle from one side to the other until the black knob clicks into the groove on the spring canister. The minimum flow required to oscillate is 175 gpm (650 l/min).

The oscillating mechanism is equipped with a safety device that prevents damage to the gear train in case the oscillator comes in contact with an object. The safety device will allow the mechanism to continue to oscillate the portion of its sweep path not blocked by the obstruction. The safety mechanism also allows the oscillating mechanism to sweep vertically without disengaging the oscillator. Once obstruction is removed, sweep pattern will return to normal.

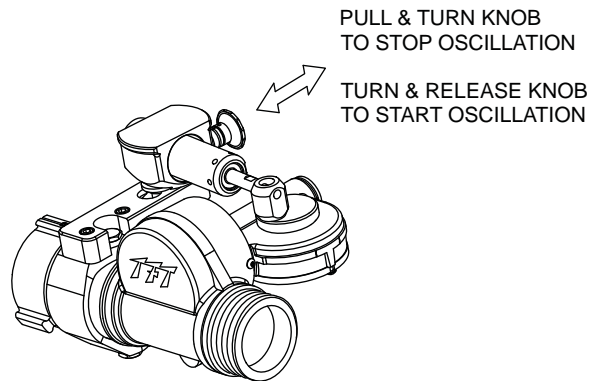

OSCILLATION CONTROL

NOTICE

The ends of the covered area will receive more water than the center because the oscillator must slow down, stop, and reverse direction at the end of each sweep. If the center area of coverage needs more cooling, it may be necessary to occasionally narrow the area of coverage or direct the stream manually.

6.4 TO DISENGAGE THE OSCILLATING MECHANISM

To operate the oscillating monitor manually, pull then twist the black knob located on the side of the monitor. Twisting will lock the knob in the disengaged position. The crank, rod, and spring canister will continue to move. Move the nozzle to the desired position by hand.

6.5 COVERAGE AREA OF OSCILLATING MONITOR

To adjust the area of coverage, refer to figure 6.3. Engage the oscillating mechanism once the desired angle has been set.

Oscillation speed: The chart shows how many times per minute the oscillator makes one complete cycle as a function of flow. The higher the flow, the faster it oscillates.

For nozzle reach, refer to the operating manual for the specific nozzle. For reach with oscillation, subtract 20% from the distance

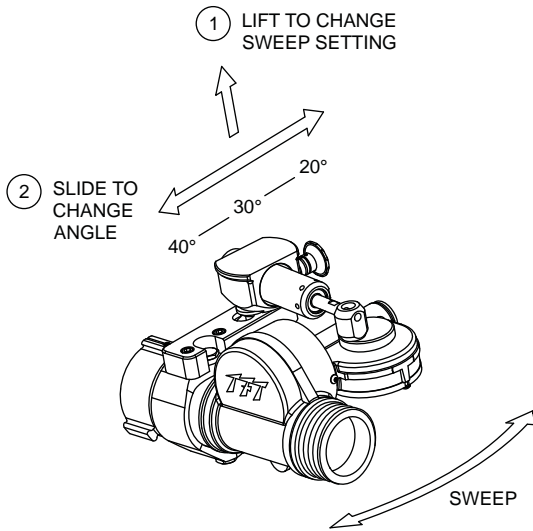
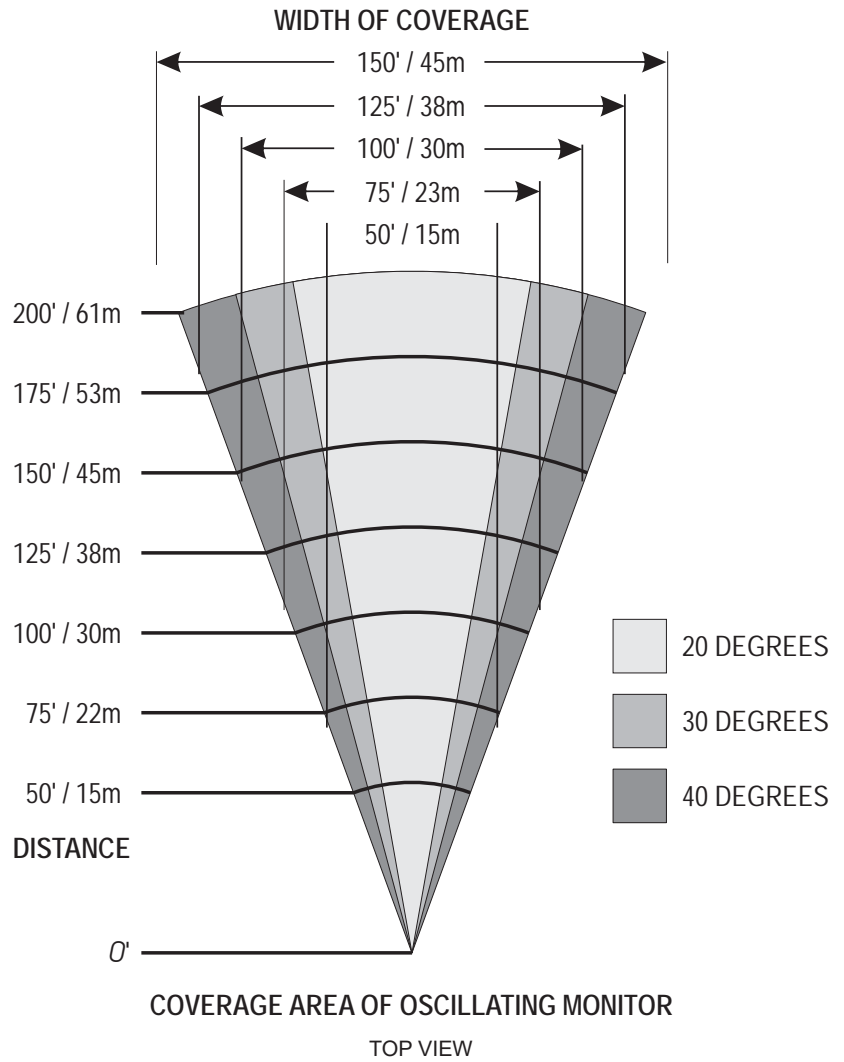

Fig. 6.3 Adjusting Sweep Angle

APPROXIMATE CYCLES/MIN	GPM	L/MIN
8	175	650
13	250	1000
21	375	1500
28	500	2000

OSCILLATION SPEED



COVERED AREA OF OSCILLATING MONITOR
TOP VIEW

NOTICE

The type of nozzle and flow pressure are critical to the coverage area. The graph shows coverage area based on the movement capability of the oscillating mechanism. Actual coverage will depend on flow, pressure, type of nozzle, angle of fog pattern and wind conditions.

7.0 OPERATION OF RC MONITORS

See Remote Control (RC) Monitor Electrical Controls Supplemental Instructions LIY-500 for operation of the Tornado RC Monitors.

8.0 RECOMMENDED PARK POSITION

For truck mounted applications it is recommended that the monitor be parked in a position such that the monitor's nozzle rests against a bracket or support surface. If a support surface is not available, run the elevation against one of its travel stops to take some of the backlash out of the gear drive. This will minimize bouncing of the nozzle when the apparatus is traveling. Always be sure the monitor is properly parked before moving the truck and know the overall height to avoid damage from overhead obstructions such as doors or bridges.

See Remote Control (RC) Monitor Electrical Controls Supplemental Instructions (LIY-500) for information on programming DEPLOY, OSCILLATE and PARK position Tornado RC models.

8.1 OVERRIDE KNOBS

In the event of electrical system failure on the monitor or fire truck the Tornado RC Monitor is factory supplied with knobs so the monitor may be manually operated. To make the Tornado RC more compact the manual override knobs may be removed. The drive shafts have a hex so an 11/16" wrench or socket may be used for manual override. The wrenching hexes are shown in figure 8.1.

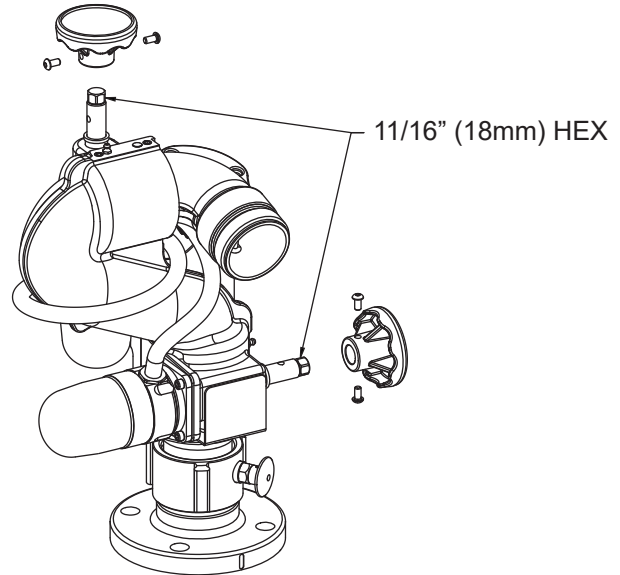

Fig 8.1
Wrenching Hexes on Drive Shafts

9.0 FLOW CHARACTERISTICS

9.1 STACKED TIPS FLOW

NOZZLE DIAMETER	NOZZLE INLET PRESSURE									
	50 PSI		80 PSI		100 PSI		150 PSI		175 PSI	
	FLOW (GPM)	REACTION (LBS)	FLOW (GPM)	REACTION (LBS)	FLOW (GPM)	REACTION (LBS)	FLOW (GPM)	REACTION (LBS)	FLOW (GPM)	REACTION (LBS)
1.0 INCH	210	80	270	120	300	150	360	230	390	260
1-1/4 INCH	330	120	410	190	460	230	—	—	—	—
1-1/2 INCH	470	170	—	—	—	—	—	—	—	—

FLOW EXCEEDS RATING OF TORNADO MONITOR

NOZZLE DIAMETER	NOZZLE INLET PRESSURE									
	4 BAR		6 BAR		8 BAR		10 BAR		12 BAR	
	FLOW (l/min)	REACTION (KG)	FLOW (l/min)	REACTION (KG)	FLOW (l/min)	REACTION (KG)	FLOW (l/min)	REACTION (KG)	FLOW (l/min)	REACTION (KG)
25 MM	830	40	1000	60	1200	80	1300	100	1400	120
32 MM	1300	70	1700	100	1900	130	—	—	—	—
38 MM	1900	90	—	—	—	—	—	—	—	—

FLOW EXCEEDS RATING OF TORNADO MONITOR

Fig. 9.1
Stacked Tips Flow Table

9.2 TORNADO MONITOR AND STREAM STRAIGHTENER FRICTION LOSS

See figure 8.2 for Tornado Monitor, Tornado OSC Monitor, and Task Force Tips 5 and 10 inch Stream Straightener friction loss.

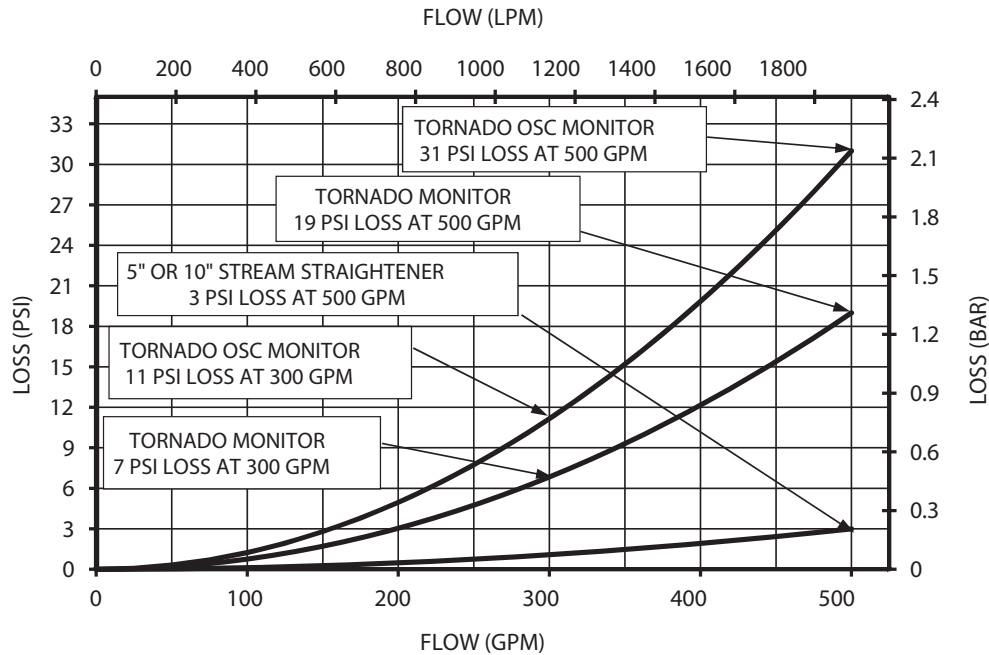

Fig 9.2
Friction Loss

9.3 STREAM STRAIGHTENERS

9.3.1 STREAM STRAIGHTENERS WITH STACKED TIPS

Turbulence through the Tornado Monitor is very low but stream quality and reach can be improved with the use of the integral stream straightener on the TFT stacked tip nozzle. See figure 8.2 for the TFT stream straightener friction loss.

9.3.2 STREAM STRAIGHTENERS WITH FOG NOZZLES

When using a fog nozzle for flows below 300 gpm (1,100 l/min), it is recommended that no stream straightener be used since the fog nozzle's flow path serves as a stream straightener. Above 300 gpm (1,100 l/min), TFT's 5 inch Stream Straightener will generally improve a fog nozzle's stream.

10.0 DRAWING & PARTS LIST

10.1 MANUAL MONITOR

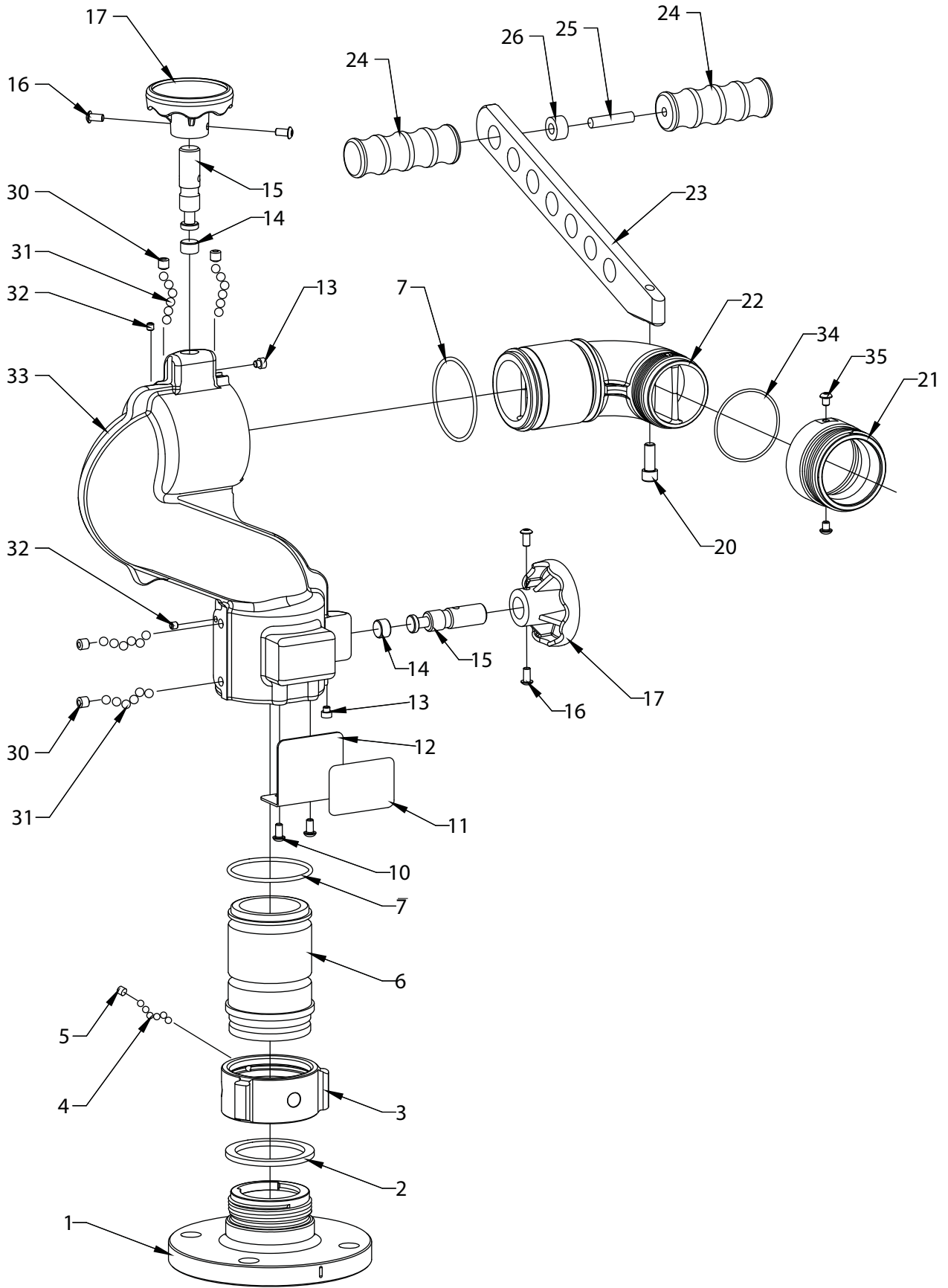

ITEM #	DESCRIPTION	QTY	PART #
1	QUICK CONNECT 2.5"NPTF ALUMINUM	1	Y2400A
	QUICK CONNECT 2.5"BSPF ALUMINUM		Y2405A
	QUICK CONNECT 2.0"NPTF ALUMINUM		Y2420A
	QUICK CONNECT 2.0"BSPF ALUMINUM		Y2425A
	QUICK CONNECT 2.5" ANSI 150 FLANGE ALUMINUM		Y2430A
2	GASKET - 2.5" HOSE COUPLING	1	V3190
3	COUPLING 2.5"NH	1	M307N
4	3/16" SS BALL	48	V2120
5	1/4-28 X 1/2 SOCKET SET SCREW	1	VT25-28SS500
6	BASE TILLER ALUMINUM	1	Y2410A
7	O-RING-233	2	VO-233
10	1/4-28 X 1/2 BUTTON HEAD SCREW	2	VT25-28BH500
11	NAME LABEL: TORNADO MONITOR	1	Y2124
12	LABEL BRACKET	1	Y2120
13	3/8-24 X 3/8 DOG POINT	2	H515
14	WEAR DISC	2	Y4191
15	LOCKING BOLT	2	Y2318
16	1/4-20 X 1/2 BUTTON HEAD SCREW	4	VT25-20BH500
17	LOCKING KNOB	2	Z245
20	3/8-16 X 1 SOCKET HEAD SCREW	1	VT37-16SH1.0
21	THREAD ADAPTER 2.5"NHM	1	Y2320ANJ
	THREAD ADAPTER 1.5"NHM		Y2320ANF
	THREAD ADAPTER 2.5"BSPM		Y2320ABJ
22	TILLER EXIT ELBOW ALUMINUM	1	Y2315A
23	TILLER HANDLE	1	Y2316
24	PEG	2	X362
25	3/8-16 X 1 3/4 STUD	1	VT37-16SD1.7
26	HANDLE BUSHING	1	Y2317
30	3/8-24 X 3/8 SOCKET SET SCREW	4	VT37-24SS375
31	5/16" BALL TORLON	120	VB.312TO
32	1/4-28 X 3/16 SOCKET SET SCREW	2	VT25-28SS187
33	LOWER SECTION TILLER ALUMINUM	1	Y2115A
34	O-RING-145	1	VO-145
35	1/4-20 X 5/16 BUTTON HEAD SCREW	2	VT25-20BH312

10.2 TORNADO OSC

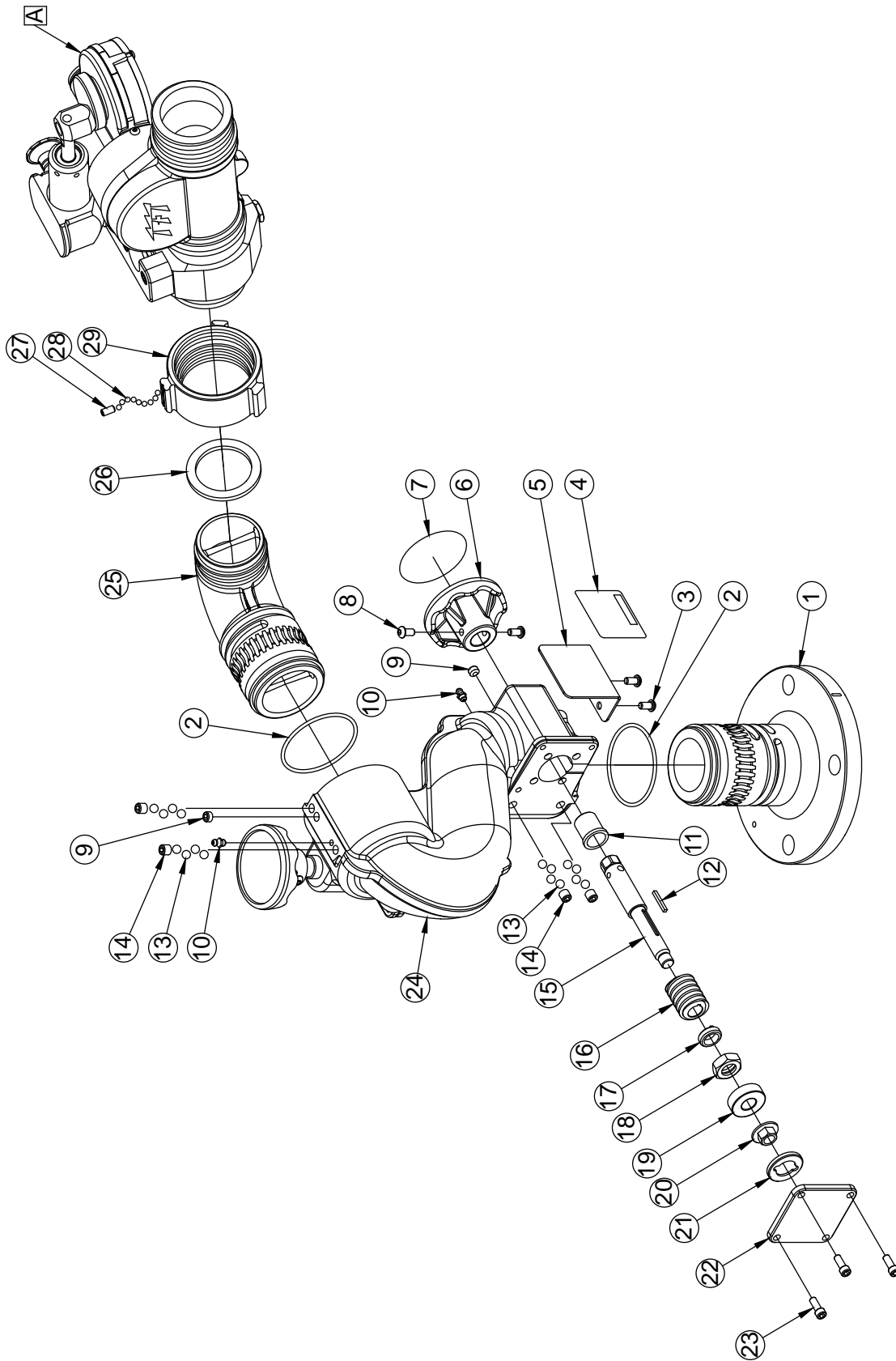

INDEX	DESCRIPTION	QTY	PART #
1	RIGID BASE 3" ANSI 150	1	Y2412
	RIGID BASE 4" ANSI 150		Y2417
2	O-RING-233	2	VO-233
3	1/4-28 X 1/2 BUTTON HEAD SCREW	2	VT25-28BH500
4	NAME LABEL: TORNADO OSC MONITOR	1	Y2125
5	LABEL BRACKET	1	Y2120
6	KNOB	1	Z245
7	OVERRIDE KNOB LABEL	1	Y4176
8	1/4-20 X 1/2 BUTTON HEAD SCREW	4	VT25-20BH500
9	3/8-24 X 1/4 SOCKET SET SCREW	2	VT37-24SS250
10	GREASE FITTING	2	VT25-28ZERK
11	HEADED BUSHING	2	Y4141
12	KEY	2	X225
13	5/16" TORLON BALL (30 PER PORT)	120	VB.312TO
14	3/8-24 X 3/8 SOCKET SET SCREW	4	VT37-24SS375
15	DRIVE SHAFT	2	Y4166
16	12 DP WORM	2	X220
17	MALE THREADED BUSHING	2	Y2175
18	FEMALE THREADED BUSHING	2	Y2176
19	BEARING	2	VM4252
20	SHAFT NUT	2	Y4167
21	BEARING RETAINER	2	Y2160
22	COVER PLATE	2	Y4164
23	1/4-28 X 5/8 SOCKET HEAD SCREW	6	VT25-28SH625
24	LOWER SECTION RC	1	Y2110
25	EXIT ELBOW	1	Y2311
26	GASKET	1	V3140
27	1/4-28 X 1/2 SOCKET SET SCREW	1	VT25-28SS500
28	3/16" TORLON BALL	48	V2120
29	COUPLING 2.5"BSPF ROCKERLUG	1	Y4168
A	OSCILLATOR	1	SEE SECTION 10.6

10.3 OSCILLATOR

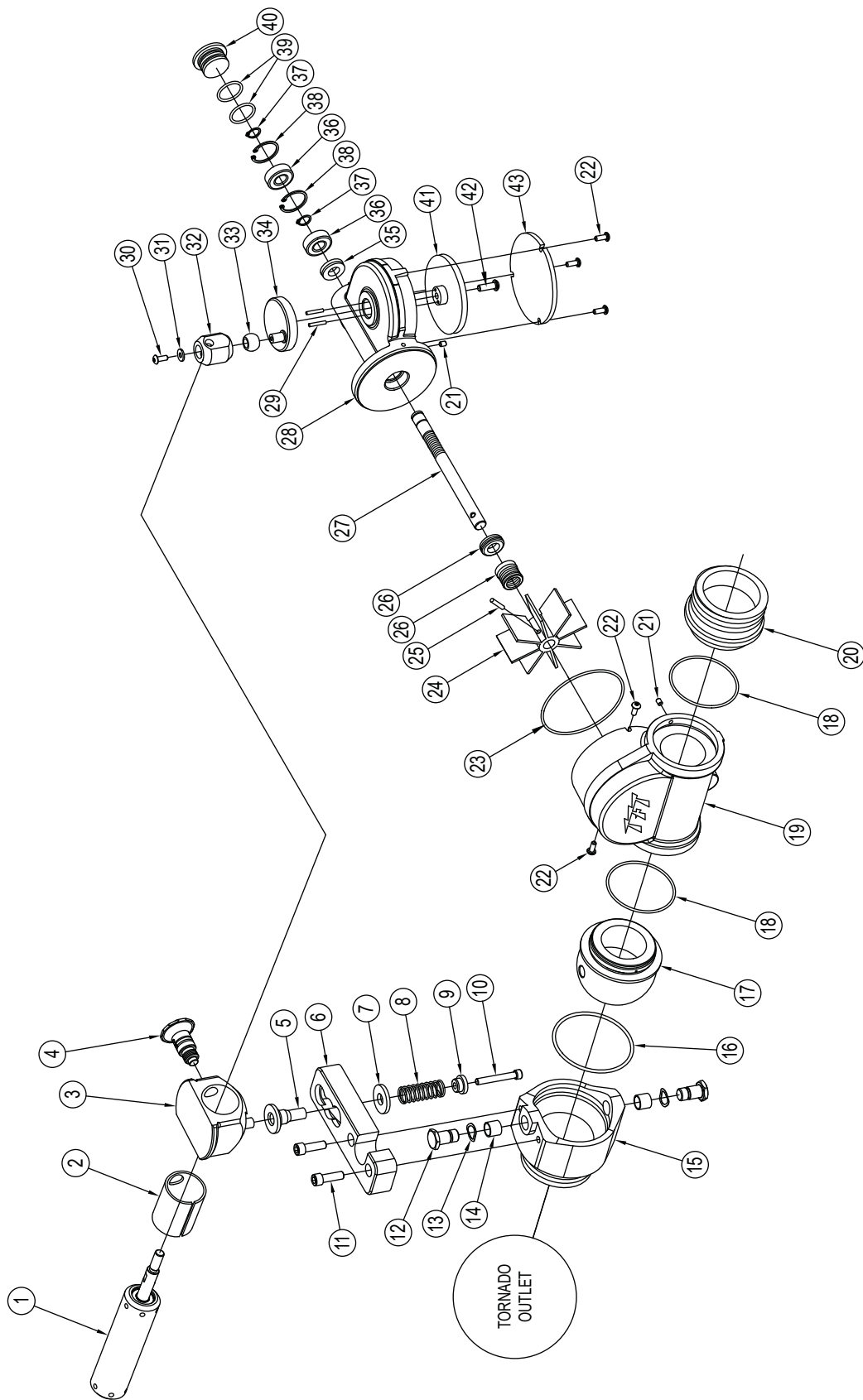

INDEX	DESCRIPTION	QTY	PART #
1	SPRING TUBE SUBASSEMBLY	1	XX808
2	SPRING TUBE BUSHING		XX382
3	SLIDER BLOCK	1	XX368
4	LATCHING PULL PIN SUBASSEMBLY	1	XX935
5	DETENT BUSHING	1	XX376
6	ARM	1	XX061
7	WASHER	1	XX377
8	SPRING	1	C031
9	SPRING RETAINER	1	XX378
10	1/4-20 X 1.75 SOCKET HEAD SCREW	1	VT25-20SH1.7
11	5/16-18 X 1 SOCKET HEAD SCREW	2	VT31-18SH1.0
12	SWIVEL TRUNNION	2	XX321
13	WAVE SPRING WASHER	2	VW740X550-16
14	BUSHING	2	Y4169
15	OSCILLATOR INLET	1	XX309
16	O-RING-235	1	VO-235
17	INLET BALL	1	XX015
18	O-RING-147	2	VO-147
19	WATERWAY	1	XX010
20	EXIT OSC 2.5"	1	XX020*
21	10-32 X 1/4 SOCKET SET SCREW	3	VT10-32SS250
22	10-32 X 1/2 BUTTON HEAD SCREW	5	VT10E32BH500
23	O-RING-153	1	VO-153
24	TURBINE VANES	1	XX025
25	5/32 X 7/8 HDP SPIROL PIN	1	V1900
26	TURBINE SEAL	1	XX032
27	WORM AND SHAFT	1	XX030
28	GEAR BOX	1	XX005
29	1/8 X 3/4 HDP SPIROL PIN	2	VP125X750H
30	10-32 X 1/2 BHCS - NYLOK PATCH	1	VT10Y32BH500
31	WASHER	1	VW500X203-60
32	OFFSET ROD END	1	XX057
33	SPHERICAL BUSHING	1	XX058
34	CRANK	1	XX362
35	CUP SEAL	1	XX033
36	WORM SHAFT BEARING	2	XX035
37	SNAP RING 1/2" EXTERNAL	2	VR4250
38	SNAP RING 1-1/8 INTERNAL	2	VR4255
39	O-RING-119	2	VO-119
40	SHAFT CAP	1	XX037
41	WORM GEAR	1	XX040
42	1/4-20 X 7/8 SOCKET HEAD SCREW	1	VT25-20SH875
43	COVER	1	XX045
* - CONSULT FACTORY FOR SPECIAL THREADS			

10.4 RC MONITOR

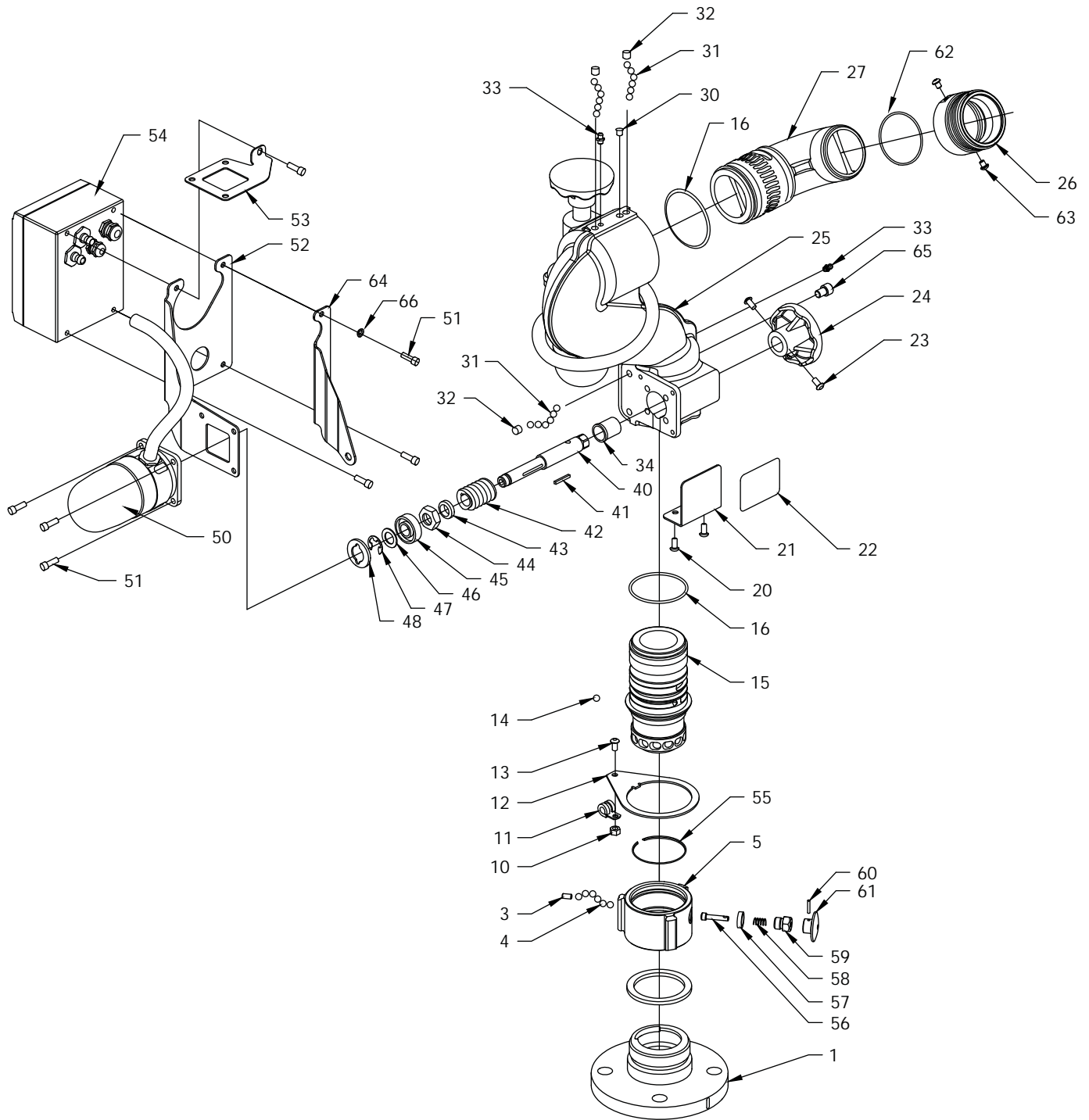

ITEM #	DESCRIPTION	QTY	PART #
1	QUICK CONNECT	1	Y2440A
2	GASKET - 2.5" HOSE COUPLING	1	V3190
3	1/4-28 X 1/2 SOCKET SET SCREW	1	VT25-28SS500
4	3/16" TORLON BALL	48	V2120-TORLON
5	COUPLING 2.5"NH	1	M306
10	1/4-20 HEX NUT	1	VT25-20NT
11	3/8 LOOP CLAMP	1	Y4655
12	WIRE CLAMP BRACKET	1	Y2135
13	1/4-20 X 3/8 BUTTON HEAD SCREW	1	VT25-20BH375
14	5/16" SS BALL	1	VB.312
15	BASE - QUICK CONNECT ALUMINUM	1	Y2411A
16	O-RING-233	2	VO-233
20	1/4-28 X 1/2 BUTTON HEAD SCREW	2	VT25-28BH500
21	LABEL BRACKET	1	Y2120
22	NAME LABEL: TORNADO RC	1	Y2122
23	1/4-20 X 1/2 BUTTON HEAD SCREW	4	VT25-20BH500
24	OVERRIDE KNOB	2	Y4165
25	LOWER SECTION RC ALUMINUM	1	Y2110A
26	THREAD ADAPTER 2.5"NHM ALUMINUM	1	Y2320ANJ
	THREAD ADAPTER 1.5"NHM ALUMINUM		Y2320ANF
	THREAD ADAPTER 2.5"BSPM ALUMINUM		Y2320ABJ
27	EXIT ELBOW ALUMINUM	1	Y2311A
30	BLACK DOME PLUG	2	VM4124
31	5/16" TORLON BALL (30) PER RACE	120	VB.312TO
32	3/8-24 X 3/8 SOCKET SET SCREW	4	VT37-24SS375
33	GREASE FITTING	2	VT25-28ZERK
34	HEADED BUSHING	2	Y4141
40	DRIVE SHAFT	2	Y4163
41	KEY	2	X225
42	WORM GEAR SINGLE LEAD	2	X220
43	MALE THREADED BUSHING	2	Y2175
44	FEMALE THREADED BUSHING	2	Y2176
45	BEARING	2	VM4252
46	WASHER	2	VW97X595-048
47	SMALLEY RING	2	VR4365
48	BEARING RETAINER	2	Y2160
50	MOTOR SUBASSEMBLY	2	SEE SECTION 9.4
51	1/4-28 X 5/8 SOCKET HEAD SCREW	10	VT25-28SH625
52	CONTROL BOX BRACKET	1	Y2130
53	CONTROL BOX SUPPORT	1	Y2131
54	CONTROL BOX SUBASSEMBLY	1	SEE SECTION 9.3
55	SMALLEY RING	1	VR4310
56	PULL PIN	1	XX340
57	SPACER	1	Y2319
58	SPRING	1	XX342
59	PULL PIN HOUSING	1	X350
60	1/8 X 3/4 HDP SPIROL PIN	1	VP125X750H
61	PULL KNOB	1	XX341
62	O-RING-145	1	VO-145
63	1/4-20 X 5/16 BUTTON HEAD SCREW	2	VT25-20BH312
64	CONTROL BOX SUPPORT	1	Y2132
65	SOCKET HEAD CAP SCREW	1	VT37-24SH500
66	WASHER	1	VW687E259-50

10.5 MONITOR CONTROL BOX

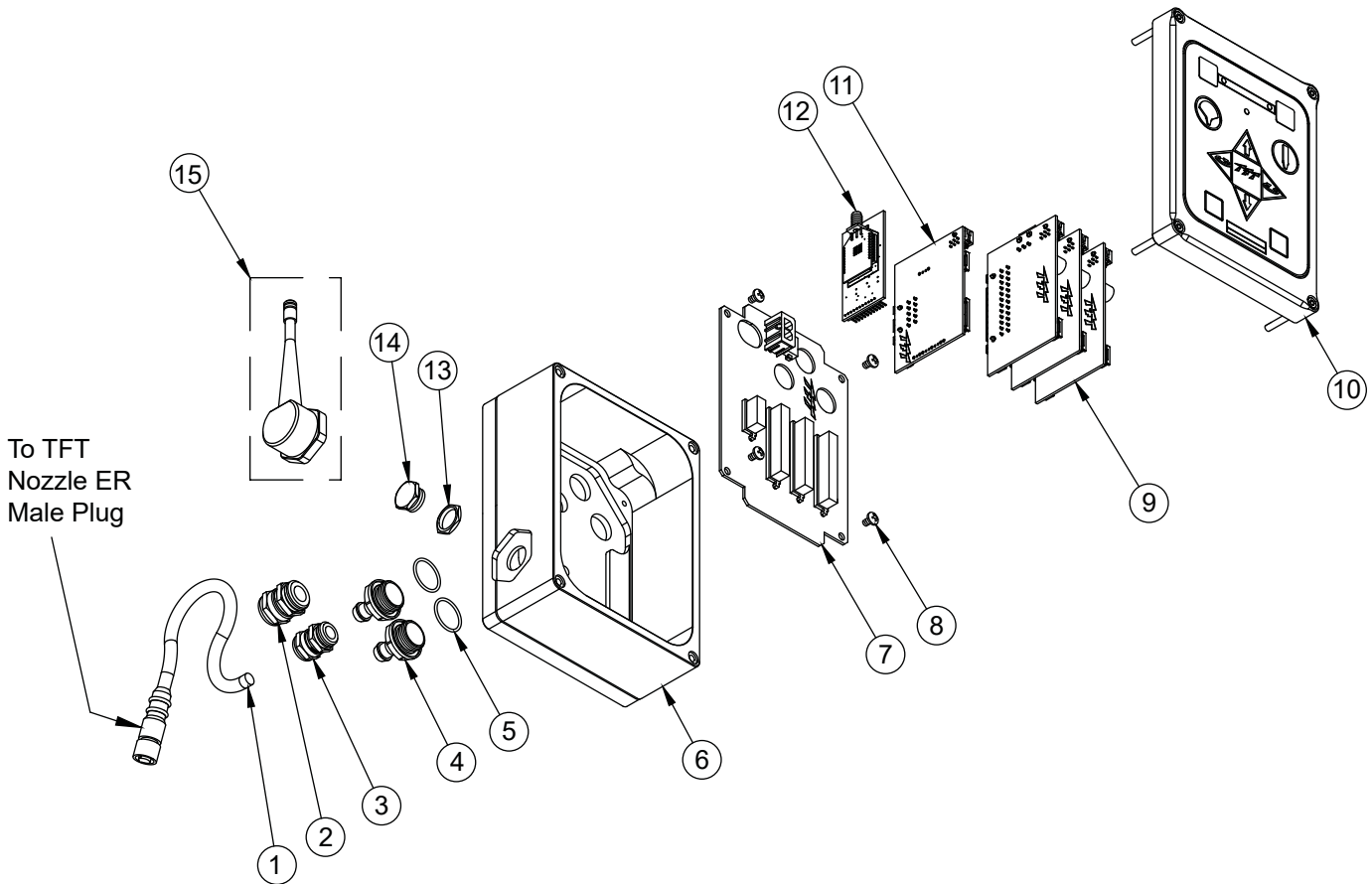

#	DESCRIPTION	QTY	PART #
1	CABLE - 6 POLE FEMALE PLUG	10" TOTAL LENGTH USED	Y5475
	FOR TORNADO RC NOZZLE CONNECTION	5" EXPOSED CABLE (NOT INCLUDING PLUG)	
2	PG11 STRAIN RELIEF	1	Y5205
3	PG9 STRAIN RELIEF	1	Y5245
4	CONDUIT FITTING	2	Y5213
5	O-RING-018	2	VO-018
6	ENCLOSURE BOX	1	Y5116B
7	MAIN BOARD	1	Y5105
8	M4-0.7 X 6MM PHILLIPS HEAD SCREW	4	VTM4-0.7PH6
9	MOTOR CONTROL BOARD	3	Y5100
10	MONITOR CONTROL BOX COVER - SUBASSEMBLY	1	Y5801-LID
11	COMMUNICATION BOARD	1	Y5110-B
*12	RADIO + ADAPTER XBEE TO XSTREAM 900 MHZ RADIO	1	Y5891
	RADIO + ADAPTER XBEE TO XSTREAM 2.4 GHZ RADIO		Y5893
13	PG9 LOCKNUT	1	Y5246
14	PG9 HEX PLUG	1	Y5248
*15	900/920 MHZ ANTENNA W/FITTING & CONN. SUBASSY.	1	Y5897
	2.4 GHZ ANTENNA ADAPTER W/CONN. SUBASSY.		Y5898
* - OPTIONAL			

10.6 MOTOR SUBASSEMBLY

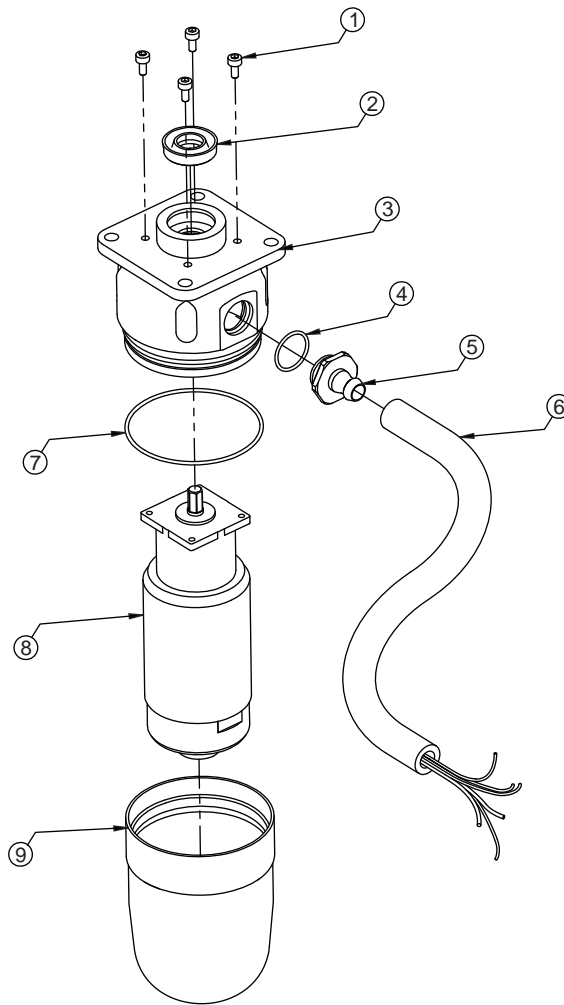

ITEM #	DESCRIPTION	QTY	PART #
1	6-32 x 5/16 LONG SHCS WITH HEAD SEAL	4	VT06S32SH312
2	CUP SEAL	1	Y4620
3	MOTOR SOCKET, ANGLED FITTING	1	Y4617
4	O-RING-018	1	VO-018
5	CONDUIT FITTING	1	Y5213
6	HOSE - 3/8" ID PUSH-LOK	1	Y5250
7	O-RING-038	1	VO-038
8	GEAR MOTOR WITH ENCODER	1	Y4600
9	ENCLOSURE	1	Y4616

10.7 RC LT MONITOR

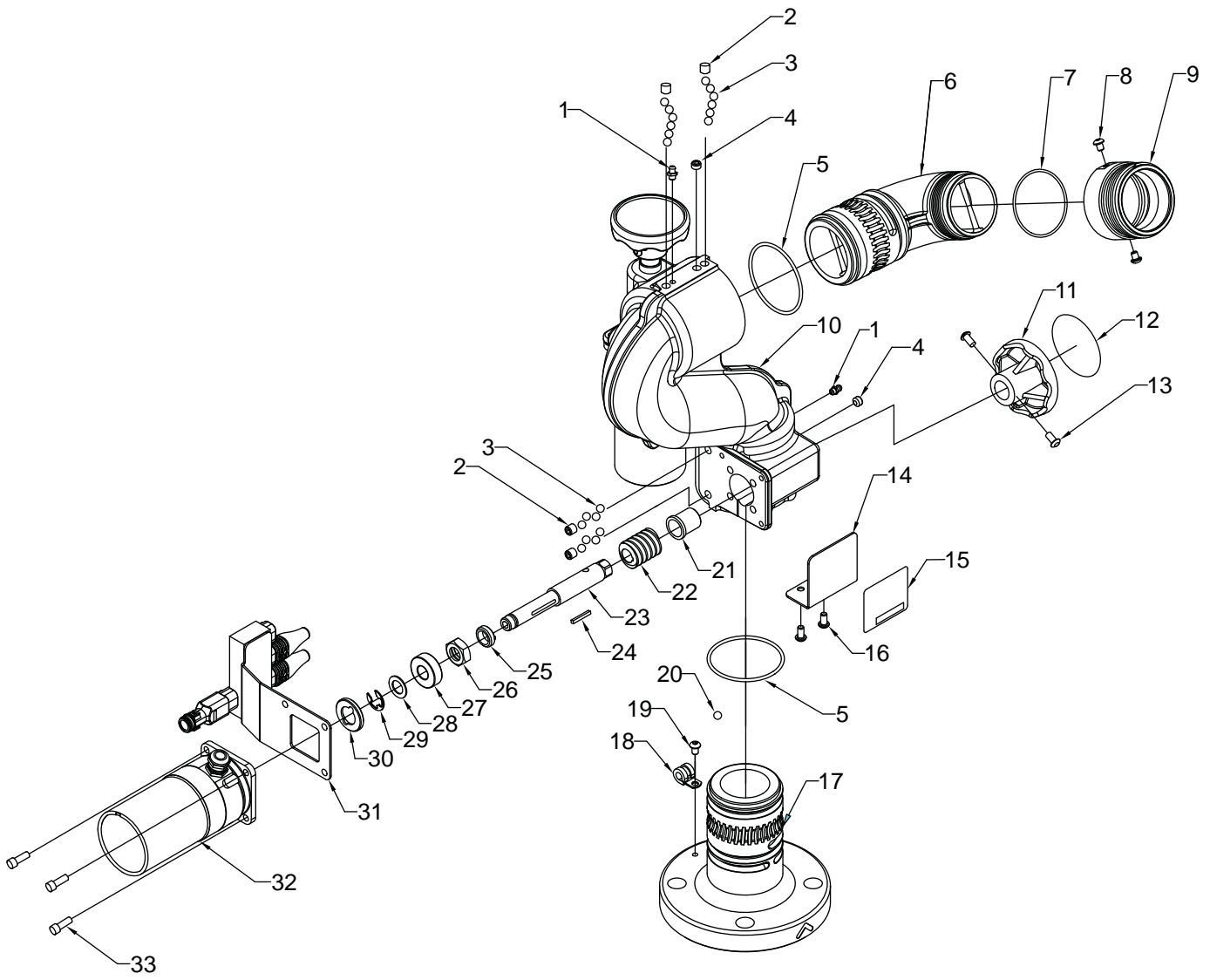

ITEM #	DESCRIPTION	QTY	PART #
1	GREASE FITTING	2	VT25-28ZERK
2	3/8-24 X 3/8 SOCKET SET SCREW	4	VT37-24SS375
3	5/16" TORLON BALL (30) PER RACE	120	VB.312TO
4	3/8-24 X 1/4 SOCKET SET SCREW	2	VT37-24SS250
5	O-RING-233	2	VO-233
6	EXIT ELBOW ALUMINUM	1	Y2310A
7	O-RING-145	1	VO-145
8	1/4-20 X 5/16 BUTTON HEAD SCREW	2	VT25-20BH312
9	THREAD ADAPTER 2.5"NHM ALUMINUM	1	Y2320ANJ
	THREAD ADAPTER 1.5"NHM ALUMINUM		Y2325ANF
	THREAD ADAPTER 2.5"BSP ALUMINUM		Y2320ABJ
	THREAD ADAPTER 1.5"BSP ALUMINUM		Y2325ABF
10	LOWER SECTION RC ALUMINUM	1	Y2110A
11	OVERRIDE KNOB	2	Y4165
12	OVERRIDE KNOB LABEL	2	Y4176
13	1/4-20 X 1/2 BUTTON HEAD SCREW	4	VT25-20BH500
14	LABEL BRACKET	1	Y2120
15	NAME LABEL: TORNADO RC	1	Y2122
16	1/4-28 X 1/2 BUTTON HEAD SCREW	2	VT25-28BH500
17	2.5" ANSI 150	1	Y2418
18	3/8 LOOP CLAMP	1	Y4655
19	1/4-20 X 3/8 BUTTON HEAD CAP SCREW	1	VT25-20BH375
20	BALL 5/16" STAINLESS	1	VB.312
21	HEADED BUSHING	2	Y4141
22	12 DP WORM	1	X220
23	DRIVE SHAFT	2	Y4163
24	KEY	2	X225
25	MALE THREADED BUSHING	2	Y2175
26	FEMALE THREADED BUSHING	2	Y2176
27	BEARING	2	VM4252
28	WASHER	2	VW97X595-048
29	SMALLEY RING	2	VR4365
30	BEARING RETAINER	2	Y2160
31	JUNCTION BOX SUBASSEMBLY	1	SEE SECTION 11.8
32	VERTICAL MOTOR SUBASSEMBLY	1	AX1660
	HORIZONTAL MOTOR SUBASSEMBLY	1	AX1661
33	1/4-28 X 5/8 SOCKET HEAD SCREW	7	VT25-28SH626

10.8 JUNCTION BOX

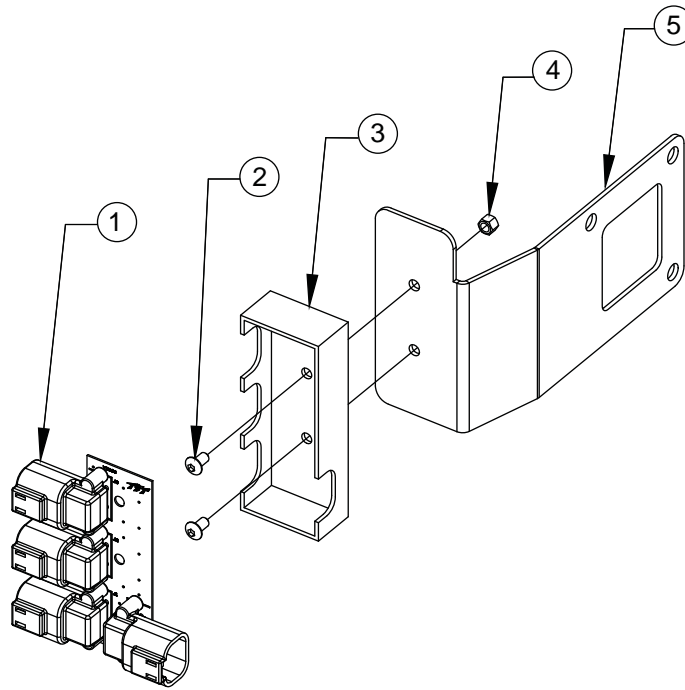

ITEM #	DESCRIPTION	QTY	PART #
1	BOARD - LT MONITOR JUNCTION BOX	1	Y5680
2	8-32 X 5/16 BUTTON HEAD CAP SCREW	2	VT08-32BH312
3	ENCLOSURE - LT MONITOR POTTING BOX	1	Y5685
4	#8-32 HEX NUT	2	VT08-32NT
5	JUNCTION BOX BRACKET	1	Y2140

11.0 WARRANTY

Task Force Tips LLC, 3701 Innovation Way, Valparaiso, Indiana 46383-9327 USA (“TFT”) warrants to the original purchaser of its nozzles and other equipment (“equipment”), and to anyone to whom it is transferred, that the equipment shall be free from defects in material and workmanship during the five (5) year period from the date of purchase.

TFT’s obligation under this warranty is specifically limited to replacing or repairing the equipment (or its parts) which are shown by TFT’s examination to be in a defective condition attributable to TFT. To qualify for this limited warranty, the claimant must return the equipment to TFT, at 3701 Innovation Way, Valparaiso, Indiana 46383-9327 USA, within a reasonable time after discovery of the defect. TFT will examine the equipment. If TFT determines that there is a defect attributable to it, it will correct the problem within a reasonable time. If the equipment is covered by this limited warranty, TFT will assume the expenses of repair.

If any defect attributable to TFT under this limited warranty cannot be reasonably cured by repair or replacement, TFT may elect to refund the purchase price of the equipment, less reasonable depreciation, in complete discharge of its obligations under this limited warranty. If TFT makes this election, claimant shall return the equipment to TFT free and clear of any liens and encumbrances.

This is a limited warranty. The original purchaser of the equipment, any person to whom it is transferred, and any person who is an intended or unintended beneficiary of the equipment, shall not be entitled to recover from TFT any consequential or incidental damages for injury to person and/or property resulting from any defective equipment manufactured or assembled by TFT. It is agreed and understood that the price stated for the equipment is in part consideration for limiting TFT’s liability. Some states or countries do not allow the exclusion or limitation of incidental or consequential damages, so the above may not apply to you.

TFT shall have no obligation under this limited warranty if the equipment is, or has been, misused or neglected (including failure to provide reasonable maintenance) or if there have been accidents to the equipment or if it has been repaired or altered by someone else.

THIS IS A LIMITED EXPRESS WARRANTY ONLY. TFT EXPRESSLY DISCLAIMS WITH RESPECT TO THE EQUIPMENT ALL IMPLIED WARRANTIES OF MERCHANTABILITY AND ALL IMPLIED WARRANTIES OF FITNESS FOR A PARTICULAR PURPOSE. THERE IS NO WARRANTY OF ANY NATURE MADE BY TFT BEYOND THAT STATED IN THE DOCUMENT.

This limited warranty gives you specific legal rights, and you may also have other rights which vary from state to state.

12.0 MAINTENANCE

The Tornado Monitor requires little maintenance. The unit should be kept clean and free of dirt by rinsing with water after each use. Any inoperable or damaged parts should be repaired or replaced before placing the unit in service. Equipment can be returned to the factory for service and/or testing.



Any alterations to the monitor and its markings could diminish safety and constitutes a misuse of this product

12.1 LUBRICATION

The Tornado monitor generally should not require greasing. In the event that the operation becomes stiff grease may be applied to the horizontal rotation and elevation worm gears. The grease is applied by removing the plugs at the grease ports and replacing with grease fittings that have 1/4-28 male threads. See figure 3.1B for grease port locations. Use medium viscosity automotive chassis grease. Apply only enough grease to restore normal operation. If normal operation is not restored by greasing than inspect for other causes of stiff operation.

Note: Do not over pump grease. The monitor’s greased areas lead to large chambers that could trap several pounds of grease before becoming visible.

12.2 TROUBLESHOOTING

SYMPTOM	POSSIBLE CAUSE	REMEDY
Leaks	Debris or damage in seal area	Clean out debris or replace damaged parts
Elevation Binding	Debris or damage to elevation drive parts	Clean out debris or replace damaged parts
	Lack of lubricant	Grease, see section 3.1
Horizontal Rotation Binding	Debris or damage to horizontal drive parts	Clean out debris or replace damaged parts
	Lack of lubricant	Grease, see section 3.1

12.3 REPAIR

Factory service is available with repair time seldom exceeding one day in our facility. Factory serviced appliances are repaired by experienced technicians to original specifications, fully tested and promptly returned.

Repair parts and service procedures are available for those wishing to perform their own repairs. Task Force Tips assumes no liability for damage to equipment or injury to personnel that is a result of user service.

For additional information on care, maintenance and testing, refer to: NFPA 1962: Standard for the Care, Use, Inspection, Service Testing, and Replacement of Fire Hose, Couplings, Nozzles, and Fire Hose Appliances, 2013 Edition

13.0 ANSWERS TO YOUR QUESTIONS

We appreciate the opportunity of serving you and making your job easier. If you have any problems or questions, our toll-free "Hydraulics Hotline", 800-348-2686, is normally available to you 24 hours a day, 7 days a week.

14.0 INSPECTION CHECKLIST

BEFORE EACH USE, appliances must be inspected to this checklist:

- All valves (if so equipped) open and close fully and smoothly
- Waterway is clear of obstructions
- There is no damage to any thread or other connection
- All locks and hold-down devices work properly
- The pressure setting on the relief valve (if so equipped) is set correctly
- Gaskets are in good repair
- There is no obvious damage such as missing, broken or loose parts
- There is no damage to the appliance that could impair safe operation (e.g. dents, cracks, corrosion, or other defects)
- All swiveling elements rotate freely
- Nozzle is securely attached

BEFORE BEING PLACED BACK IN SERVICE, appliances must be inspected to this list:

1. All valves open and close smoothly and fully
2. The waterway is clear of obstructions
3. There is no damage to any thread or other type connection
4. The pressure setting of the relief valve, if any, is set correctly
5. All locks and hold-down devices work properly
6. Internal gaskets are in accordance with NFPA 1962 (2013) Section 7.2
7. There is no damage to the appliance that could impair safe operation (e.g. dents, cracks, corrosion, or other defects)
8. All swiveling connections rotate freely
9. There are no missing parts or components
10. The marking for maximum operating pressure is visible
11. There are no missing, broken, or worn lugs on couplings

NFPA 1962: Standard for the care, use, inspection, service testing, and replacement of fire hose, couplings, nozzles and fire hose appliances. (2013 ed., Section 6.2.1). Quincy, MA: National Fire Protection Agency.



Any monitor failing any part of the inspection checklist is unsafe and must have the problem corrected before use. Operating a monitor that fails any of the above inspections is a misuse of this equipment.