



MANUAL: TORNADO & TORNADO RC MONITOR

See Remote Control (RC) Monitor Electrical Controls Supplemental Instructions For Use With Tornado RC Models

INSTRUCTIONS FOR INSTALLATION, SAFE OPERATION AND MAINTENANCE

⚠ DANGER

Read instruction manual before use. Operation of this device without understanding the manual and receiving proper training is a misuse of this equipment. A person who has not read and understood all operating and safety instructions is not qualified to operate the Tornado or Tornado RC Monitor.

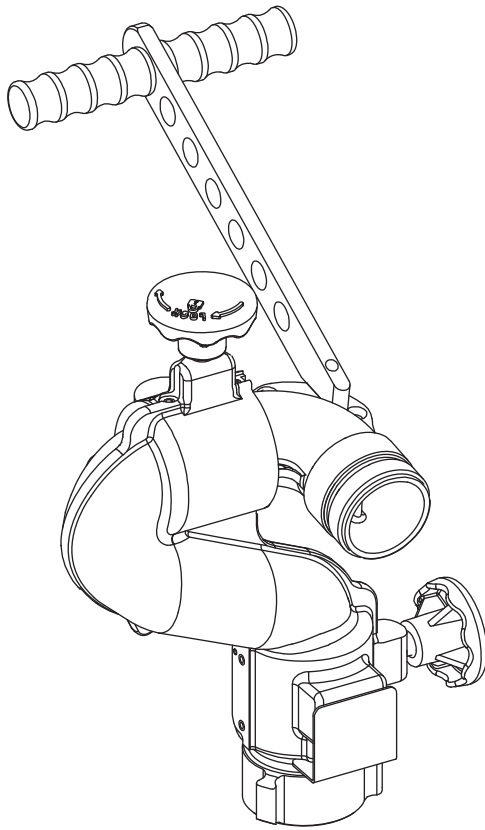

TORNADO 

**Maximum Recommended Flow
is 500 gpm (1900 l/min)
Maximum Recommended Pressure
is 200 psi (14 bar)**

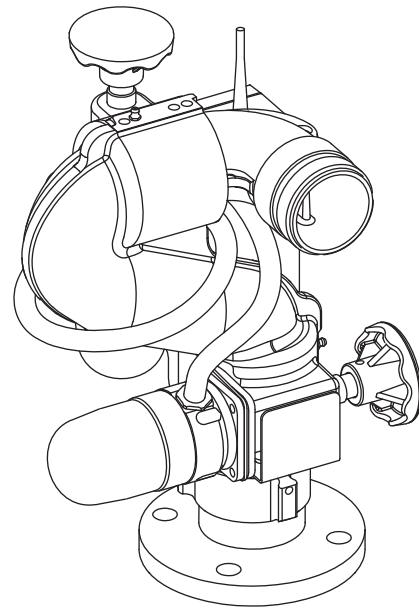

TORNADO RC 

TASK FORCE TIPS, INC.
MADE IN USA • www.tft.com

2800 East Evans Avenue, Valparaiso, IN 46383-6940 USA
800-348-2686 • 219- 462-6161 • Fax 219-464-7155

DANGER

PERSONAL RESPONSIBILITY CODE

The member companies of FEMSA that provide emergency response equipment and services want responders to know and understand the following:

1. Firefighting and Emergency Response are inherently dangerous activities requiring proper training in their hazards and the use of extreme caution at all times.
2. It is your responsibility to read and understand any user's instructions, including purpose and limitations, provided with any piece of equipment you may be called upon to use.
3. It is your responsibility to know that you have been properly trained in Firefighting and /or Emergency Response and in the use, precautions, and care of any equipment you may be called upon to use.
4. It is your responsibility to be in proper physical condition and to maintain the personal skill level required to operate any equipment you may be called upon to use.
5. It is your responsibility to know that your equipment is in operable condition and has been maintained in accordance with the manufacturer's instructions.
6. Failure to follow these guidelines may result in death, burns or other severe injury.



Fire and Emergency Manufacturers and Service Association
P.O. Box 147, Lynnfield, MA 01940 • www.FEMSA.org

Table Of Contents

1.0	Meaning of Safety Signal Words.....	3
2.0	Safety.....	4
3.0	General Information	4-7
3.1	Mechanical Specifications	
3.2	Part Identification and Models	
3.3	Inlets and Outlets	
3.4	Overall Dimensions	
4.0	Installation.....	8-10
4.1	Structural Requirements for Monitor Mounting	
4.2	Quick Connect Inlet Mounting and Travel Ranges	
4.3	Nozzle Installation	
4.4	Pressure Gage Port	
4.5	Drain	
5.0	Recommended Park Position	10
5.1	Override Knobs	
6.0	Flows and Pressures	11
6.1	Stacked Tips Flow	
6.2	Tornado Monitor and Stream Straightener Friction Loss	
6.3	Stream Straighteners	
6.3.1	Stream Straighteners with Stacked Tips	
6.3.2	Stream Straighteners with Fog Nozzles	
7.0	Maintenance and Inspection.....	12
7.1	Lubrication	
7.2	Performance Testing	
8.0	Troubleshooting	12
9.0	Drawings and Parts List	13-19
10.0	Warranty.....	Back Cover

1.0 MEANING OF SAFETY SIGNAL WORDS

A safety related message is identified by a safety alert symbol and a signal word to indicate the level of risk involved with a particular hazard. Per ANSI standard Z535.6-2006, the definitions of the four signal words are as follows:



DANGER indicates a hazardous situation which, if not avoided, will result in death or serious injury.



WARNING indicates a hazardous situation which, if not avoided, could result in death or serious injury.



CAUTION indicates a potentially hazardous situation which, if not avoided, may result in minor or moderate injury.



NOTICE is used to address practices not related to personal injury.

2.0 SAFETY

The operation of this monitor can be dangerous. The following must be observed at all times.

WARNING Injury or death may occur by attempting to use a damaged monitor. Before using the monitor inspect it for damage resulting from:

- Failure to drain monitor followed by exposure to freezing conditions
- Exposure of monitor to temperatures in excess of 160 degrees F
- Structural damage caused by over-pressurization
- Missing parts, physical abuse, exposure to severe chemicals
- Deformed or cracked flanges damaged as a result of improper installation
 - Excessive bolt torque
 - Wrong tightening sequence

WARNING Injury can result from an inadequately supported monitor. The monitor mount must be capable of supporting 400 lbs (180 kg) of nozzle reaction force.

WARNING The stream exiting a monitor is very powerful and capable of causing injury and property damage. Make sure the monitor is securely attached to the base and pointing in a safe direction before water to the monitor is turned on. Use care in directing the stream.

CAUTION The electric Tornado RC may be remotely operated. The electric drives are current limited but may still produce enough force to cause injury. Keep hands and fingers away from pinch points on the monitor.

CAUTION Do not use the manual override knobs while the electric controls are in operation. The electric drives produce enough torque to cause injury.

CAUTION Maximum flow and pressure is 500 gpm (1900 l/min) and 200 psi (14 bar). Damage or injury may result if the monitor is operated beyond these limits.

CAUTION On many vehicle installations, the monitor is the highest point on the apparatus. Be sure there is sufficient clearance to safely pass under any doors or overhead obstructions. Always check parked position of the monitor before moving.

3.0 GENERAL INFORMATION

The Tornado monitor is a 2-inch, 500 gpm maximum monitor. It is available in a manually operated model as well as an electric remote controlled model. The electric remote controlled model is known as the Tornado RC. Further specifications are shown in the following sections and in the Remote Control (RC) Monitor Electrical Controls Supplemental Instructions for Tornado RC models.

3.1 MECHANICAL SPECIFICATIONS

Weight	Manual	12 lbs	5.5 kg
	Electric	25 lbs	11.4 kg
Min. Flow Area		8.3 in ²	24.5 cm ²
Max Flow		500 gpm	1900 l/min
Max Operating Pressure		200 psi	14 bar
Horizontal Travel Range		360° Continuous Manual	
		370° (185° left and right) Electric	
Standard Inlets		2.5"-7.5 NH Female 2.0"-11 BSP Female 2.0"-11.5 NPT Female 3.0"-8 NPT Female	2.5"-11 BSP Female 2.5" ANSI 150 Flange 2.5"-8 NPT Female TFT Code-RLF (fits Extend-A-Gun RC3)
Standard Outlets		2.5"-7.5 NH Male 2.5"-11 BSP Male 1.5"-9 NH Male	
Materials Used		ANSI A356.0-T6 Aluminum, Stainless, Nylon	

3.2 PART IDENTIFICATION AND MODELS

The Tornado and Tornado RC Monitor are shown in figs 3.2A and 3.2B along with the names of some various parts and controls.

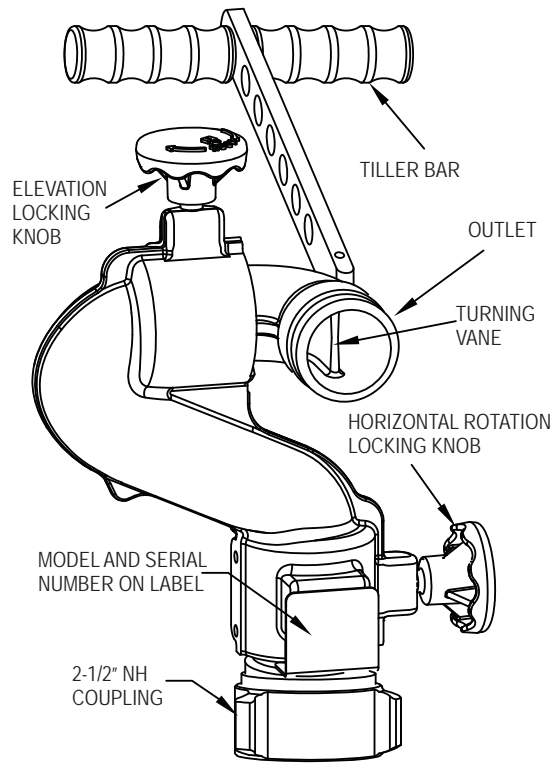

Fig. 3.2A Manual Tornado Monitor Part Identification

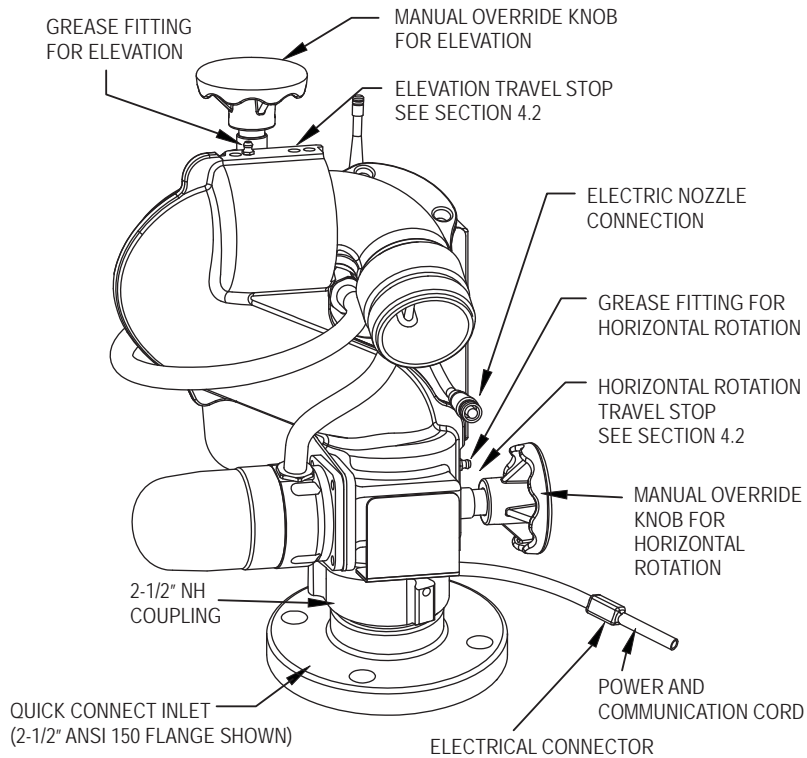

Fig. 3.2B Tornado RC Monitor Part Identification

3.3 INLETS AND OUTLETS

Available inlets and outlets are shown below and should be specified at time of order.

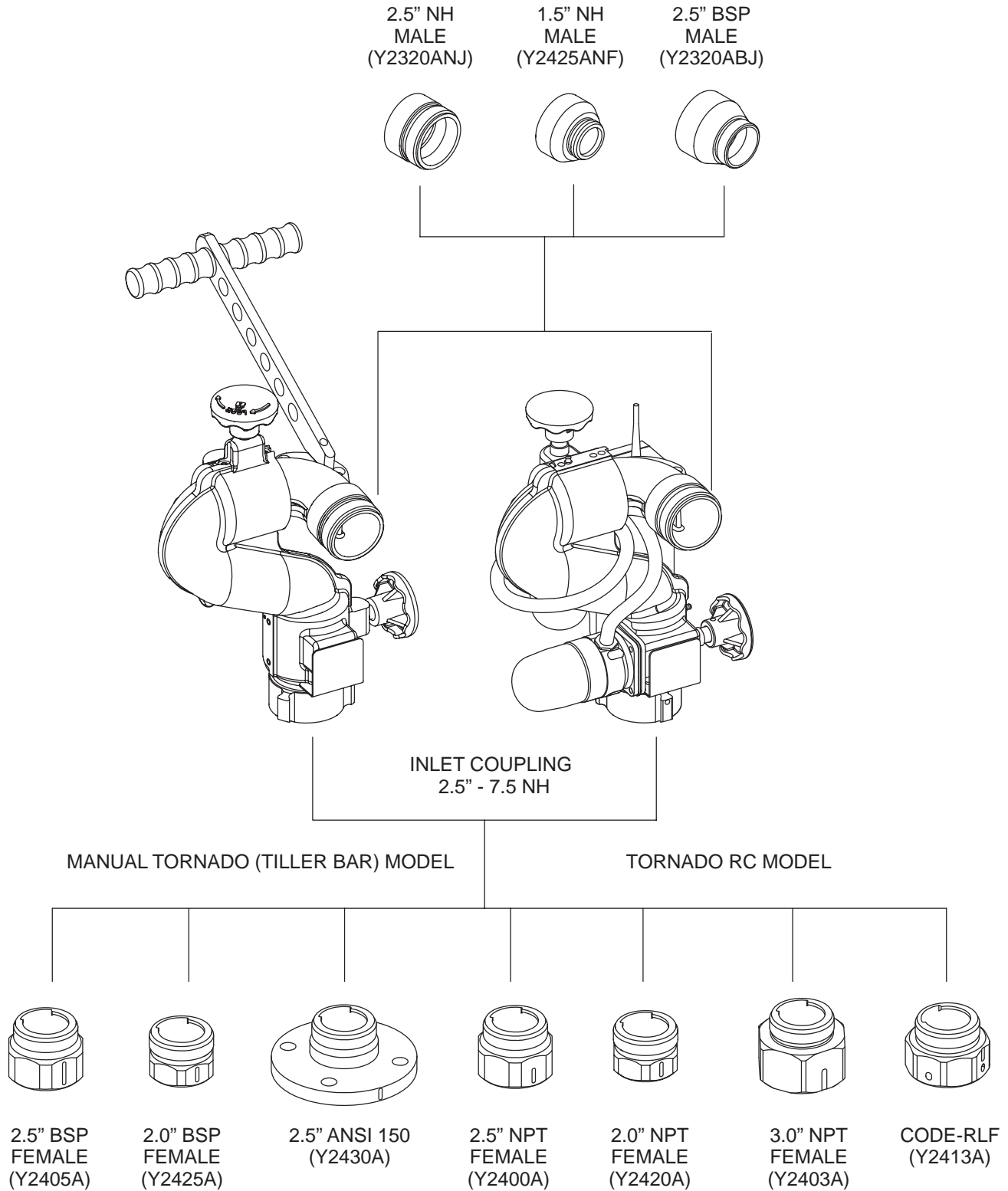

Fig 3.3
Inlets and Outlets

3.4 OVERALL DIMENSIONS

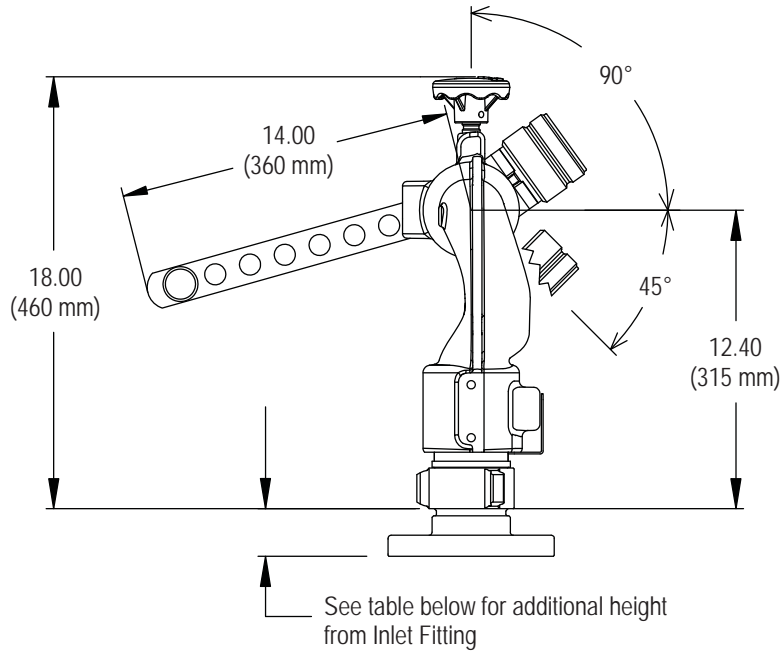
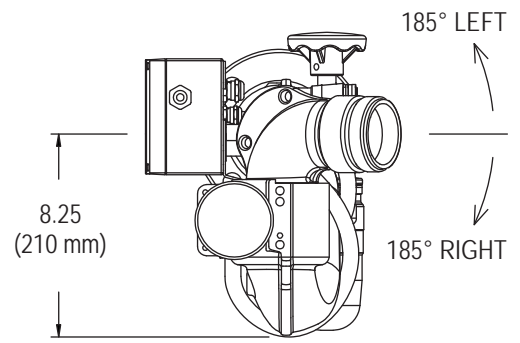
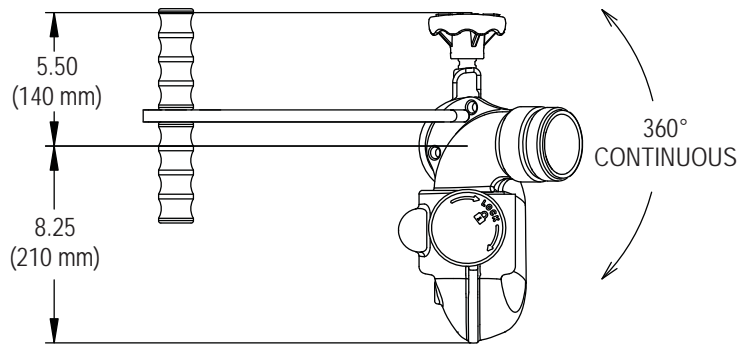

Fig 3.4a
Manual Tornado Monitor Dimensions

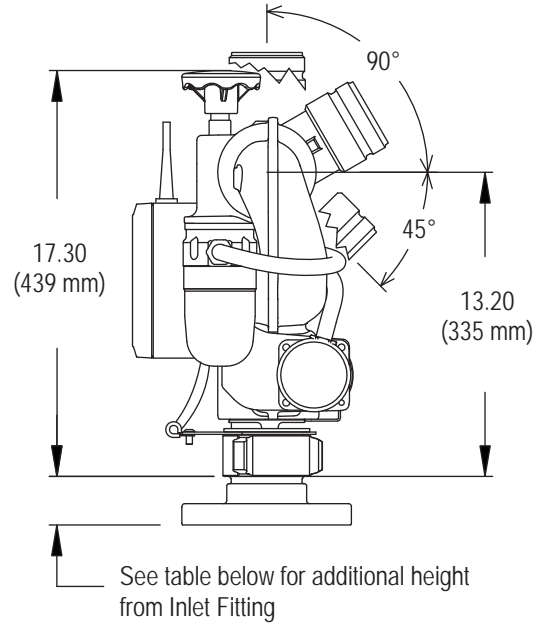

Fig 3.4b
Electric Tornado RC Monitor Dimensions

MODEL	INLET FITTING TYPE	ADDITIONAL HEIGHT
Y2-*1*A	2-1/2" - 7.5 NH FEMALE (no inlet fitting)	0.00" 0 mm
Y2-*2*A	2-1/2" - 11 BSP FEMALE	2.00" 51 mm
Y2-*3*A	2.0" - 11.5 BSP FEMALE	1.50" 38 mm
Y2-*6*A	2.5" ANSI 150 FLANGE	2.00" 51 mm
Y2-*7*A	2-1/2" - 8 NPT FEMALE	2.00" 51 mm
Y2-*8*A	2.0" - 11.5 NPT FEMALE	1.50" 38 mm
Y2-*9*A	3.0" - 8 NPT FEMALE	2.44" 62 mm
Y2-*L*A	TFT CODE-RLF (fits Extend-A-Gun RC3)	2.00" 51 mm

4.0 INSTALLATION

See Remote Control (RC) Monitor Electrical Controls Supplemental Instructions For Use With Tornado RC Models

4.1 STRUCTURAL REQUIREMENTS FOR MONITOR MOUNTING

The structure that the Tornado Monitor is mounted to must withstand the internal pressure of the monitor, as well as shear and bending forces due to nozzle reaction. Nozzle reaction can be as high as 400 lbs (180 kg) (500 gpm at 200 psi).

For flanged connections, the use of flat flanges without raised faces is recommended. Use a ring gasket as defined in ASME 16.21 or ISO 7483. Tighten flange bolts in an alternating sequence as shown in figure 4.1. Tighten to 76-80 ft-lb (100-110 Newton-Meters).

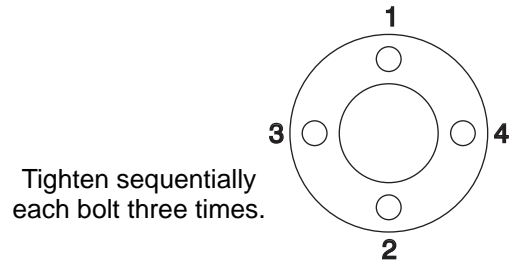

Fig 4.1 Flange Bolt Tightening Sequence



Injury can result from an inadequately supported monitor. The monitor mount must be capable of supporting the nozzle reaction force which can be as high as 400 lbs (180 kg). Flanges and pipe made from plastic are inadequate for monitor mounting and must not be used. This monitor is not recommended for portable use.

4.2 QUICK CONNECT INLET MOUNTING AND TRAVEL RANGES

Figure 3.3 shows the various Inlet Adapters used on the Tornado. These Inlet Adapters must be oriented upon installation so the Tornado will point in the desired direction. Figure 4.2A shows examples of Inlet Adaptors and the location of a "Straight Ahead Reference Mark". This figure also gives some information about securing the Tornado to the Inlet Adapter. Travel ranges relative to the Straight Ahead Reference Mark are shown in Figure 4.2B. Figure 4.2C gives the location of the "Stop Bolts", which are used to limit the travel.

IMPORTANT: Install so Straight Ahead Reference Mark is facing the desired direction.

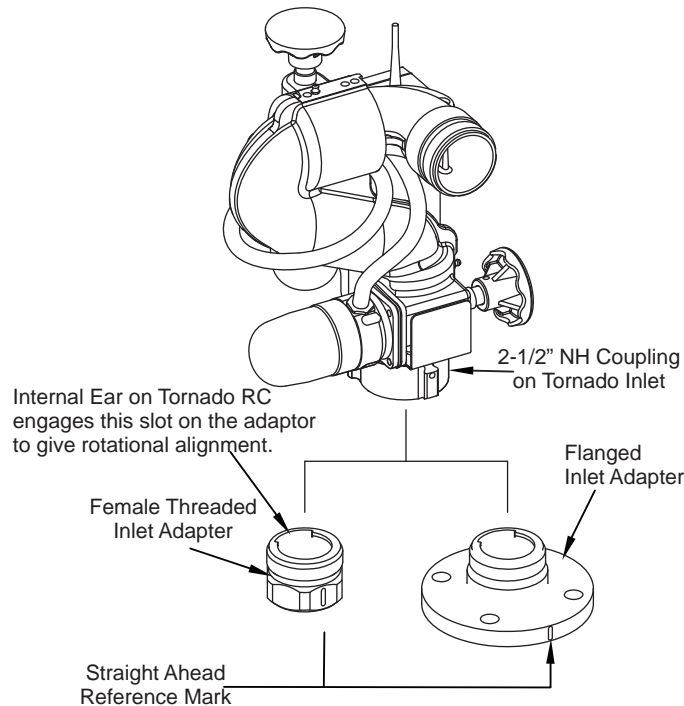

Fig 4.2A
Inlet Adapter and Straight Ahead Reference Mark

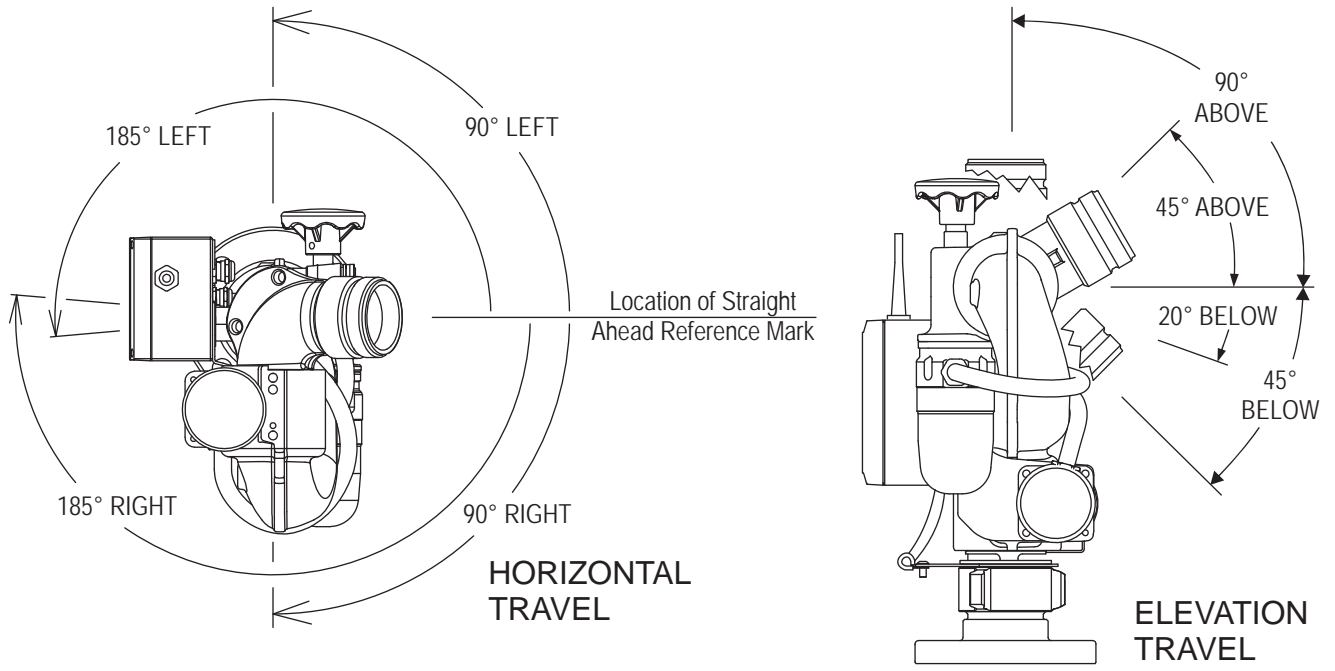

Fig 4.2B Travel Ranges Relative to Straight Ahead Reference Mark

Remove set screw and install Stop Bolt to obtain desired travel limits.
 RC model with no stop bolts installed has 185° left and right travel limits.
 Tiller model has continuous 360° horizontal rotation. Stop Bolts are not used on Tiller model.

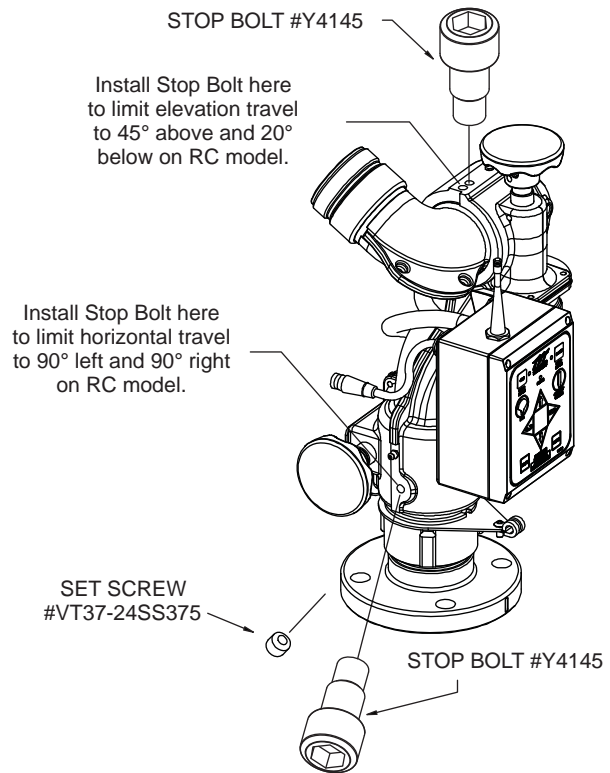

Fig 4.2C Stop Bolt Use

4.3 NOZZLE INSTALLATION

The nozzle is simply screwed onto the monitor's exit threads.



The nozzle threads must match the threads of the Tornado monitor in both size and type. Mismatched or damaged threads may cause the nozzle to leak or uncouple under pressure and could cause injury.



Do not connect aluminum to brass or brass to aluminum. Dissimilar metals coupled together can cause galvanic corrosion that will freeze the threaded joint or cause complete loss of thread engagement. If dissimilar metals must be coupled together, the effects of corrosion can be greatly delayed by various coatings on the metal such as powder paint, hard anodizing, or silicone grease.

4.4 PRESSURE GAGE PORT

There is a raised boss on the back of the monitor. This raised boss is not machined from the factory but may be drilled and tapped for 1/4 NPT threads if a pressure gage is desired on the monitor.

4.5 DRAIN

There is no drain on the Tornado Monitor itself. A drain valve should be installed on the monitor's inlet piping.

5.0 RECOMMENDED PARK POSITION

For truck mounted applications, it is recommended that the monitor be parked in a position such that the monitor's nozzle rests against a bracket or support surface. This will minimize bouncing of the nozzle when the apparatus is traveling. Always be sure the monitor is properly parked before moving the truck and know the overall height to avoid damage from overhead obstructions such as doors or bridges.

5.1 OVERRIDE KNOBS

In the event of electrical system failure on the monitor or fire apparatus, the Tornado RC Monitor is factory supplied with override knobs so the monitor may be manually operated. If desired, the override knobs may be removed. The drive shafts have a hex so a wrench or socket may be used for manual override. The wrenching hexes are shown in figure 5.1.

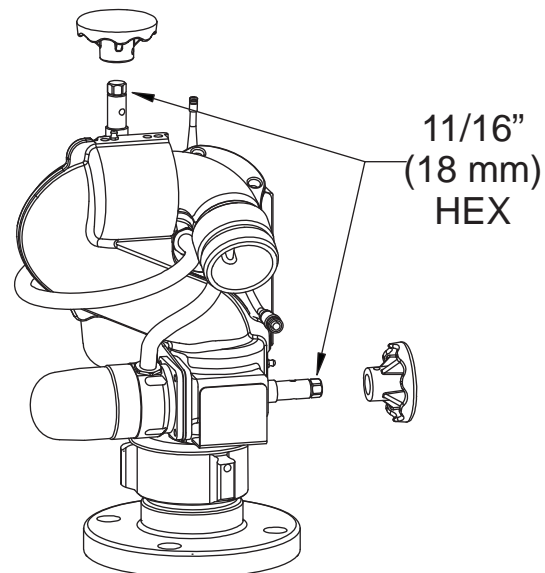

Fig 5.1
Wrenching Hexes on Drive Shafts

6.0 FLOWS AND PRESSURES

6.1 STACKED TIPS FLOW

NOZZLE DIAMETER	NOZZLE INLET PRESSURE									
	50 PSI		80 PSI		100 PSI		150 PSI		175 PSI	
	FLOW (GPM)	REACTION (LBS)	FLOW (GPM)	REACTION (LBS)	FLOW (GPM)	REACTION (LBS)	FLOW (GPM)	REACTION (LBS)	FLOW (GPM)	REACTION (LBS)
1.0 INCH	210	80	270	120	300	150	360	230	390	260
1-1/4 INCH	330	120	410	190	460	230	—	—	—	—
1-1/2 INCH	470	170	—	—	—	—	—	—	—	—

FLOW EXCEEDS RATING OF TORNADO MONITOR

NOZZLE DIAMETER	NOZZLE INLET PRESSURE									
	4 BAR		6 BAR		8 BAR		10 BAR		12 BAR	
	FLOW (l/min)	REACTION (KG)	FLOW (l/min)	REACTION (KG)	FLOW (l/min)	REACTION (KG)	FLOW (l/min)	REACTION (KG)	FLOW (l/min)	REACTION (KG)
25 MM	830	40	1000	60	1200	80	1300	100	1400	120
32 MM	1300	70	1700	100	1900	130	—	—	—	—
38 MM	1900	90	—	—	—	—	—	—	—	—

FLOW EXCEEDS RATING OF TORNADO MONITOR

Fig. 6.1
Stacked Tips Flow Table

6.2 TORNADO MONITOR AND STREAM STRAIGHTENER FRICTION LOSS

See figure 6.2 for Tornado Monitor and Task Force Tips 5 and 10 inch Stream Straightener friction loss.

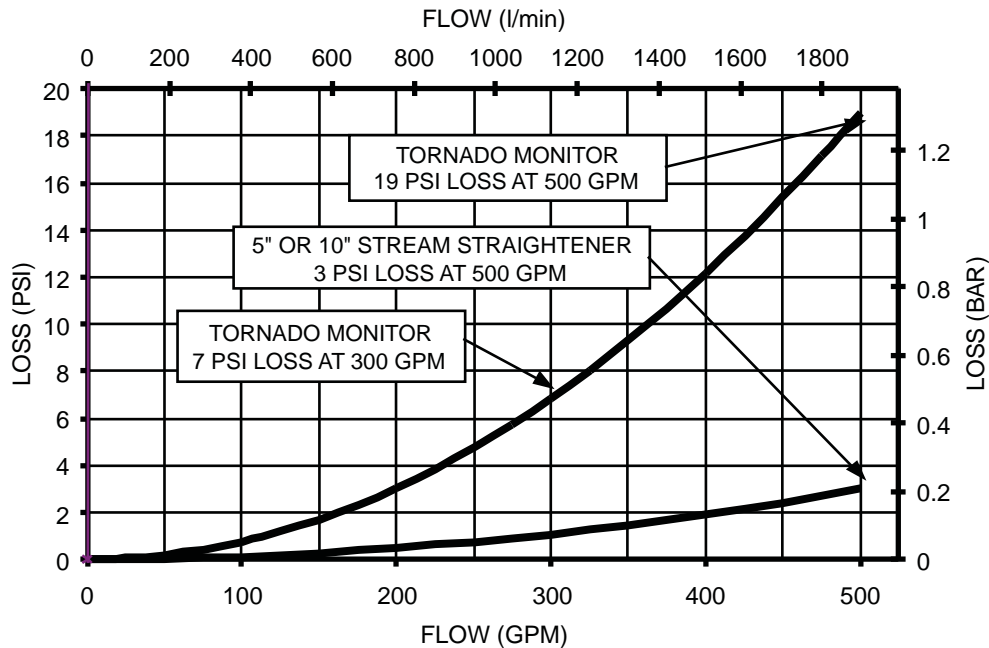

Fig 6.2
Friction Loss

6.3 STREAM STRAIGHTENERS

6.3.1 STREAM STRAIGHTENERS WITH STACKED TIPS

Turbulence though the Tornado Monitor is very low, but stream quality and reach can be improved with the use of a stream straightener on the TFT stacked tip nozzle. See figure 6.2 for the TFT stream straightener friction loss.

6.3.2 STREAM STRAIGHTENERS WITH FOG NOZZLES

When using a fog nozzle for flows below 300 gpm (1,100 l/min), it is recommended that no stream straightener be used since the fog nozzle's flow path serves as a stream straightener. Above 300 gpm (1,100 l/min), TFT's 5 inch Stream Straightener will generally improve a fog nozzle's stream.

7.0 MAINTENANCE AND INSPECTION

The Tornado Monitor requires little maintenance. The monitor should be kept clean and free of dirt. All controls should be checked for freedom of movement and proper operation periodically. Any inoperable or damaged parts should be repaired or replaced immediately.

Make sure that the monitor rotates freely and without binding throughout its range of travel.

Make sure that there are no leaks when the monitor is flowing water.

Make sure the nozzle is free of debris.

7.1 LUBRICATION

The Tornado monitor generally should not require greasing. In the event that the operation becomes stiff, grease may be applied to the horizontal rotation and elevation worm gears. See figure 3.2B for grease port locations. Use medium viscosity automotive chassis grease. Apply only enough grease to restore normal operation. If normal operation is not restored by greasing, inspect for other causes of stiff operation.

Note: Do not over pump grease. The grease fittings are located close to the seals and only an ounce or so of grease should be sufficient.

7.2 PERFORMANCE TESTING

Performance tests should be conducted on the Tornado Monitor after repairs are made, or any time a problem is reported to verify operation in accordance with Task Force Tips test procedures. Consult the factory for the procedure that corresponds to the model and serial number of your monitor. Any equipment that fails the test criteria should be removed from service immediately. Equipment can be returned to the factory for service and testing.

8.0 TROUBLESHOOTING

SYMPTOM	POSSIBLE CAUSE	REMEDY
Leaks	Debris or damage in seal area	Clean out debris or replace damaged parts
Elevation Binding	Debris or damage to elevation drive parts	Clean out debris or replace damaged parts
	Lack of lubricant	Grease, see section 7.1
Horizontal Rotation Binding	Debris or damage to horizontal drive parts	Clean out debris or replace damaged parts
	Lack of lubricant	Grease, see section 7.1

9.0 TORNADO DRAWING & PARTS LIST

9.1 MANUAL TORNADO DRAWING & PARTS LIST	14-15
9.2 TORNADO RC DRAWING & PARTS LIST.....	16-17
9.3 MONITOR CONTROL BOX	18
9.4 MOTOR SUBASSEMBLY	19

9.1 MANUAL TORNADO DRAWING & PARTS LIST

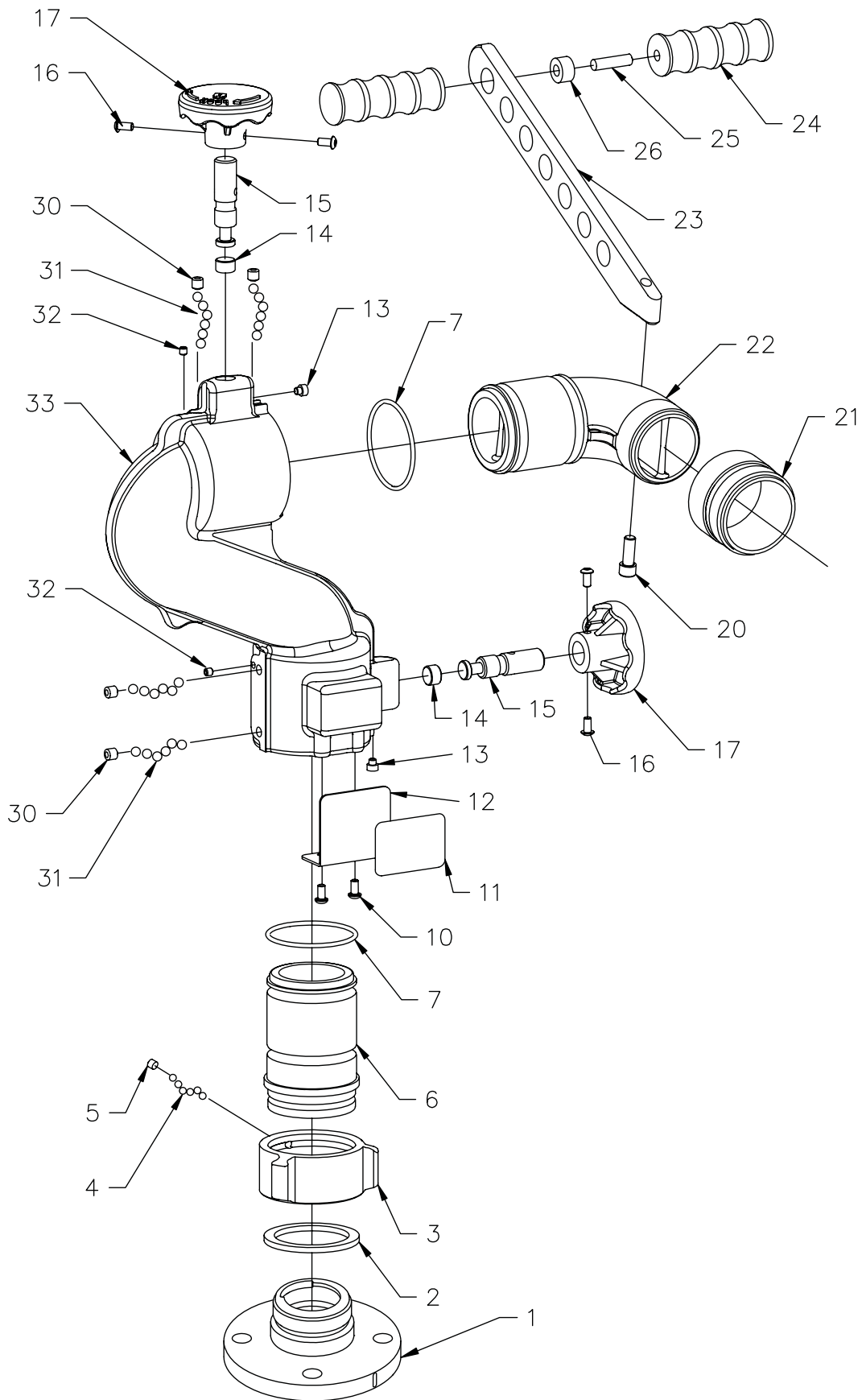

Fig 9.1
Manual Tornado Exploded View

MANUAL TORNADO PARTS LIST

#	DESCRIPTION	QTY	PART #
1	QUICK CONNECT 2.0"NPT FEMALE ALUMINUM	1	Y2420A
	QUICK CONNECT 2.5"NPT FEMALE ALUMINUM		Y2400A
	QUICK CONNECT 3.0"NPT FEMALE ALUMINUM		Y2403A
	QUICK CONNECT 2.0"BSP FEMALE ALUMINUM		Y2425A
	QUICK CONNECT 2.5"BSP FEMALE ALUMINUM		Y2405A
	QUICK CONNECT 2.5" ANSI 150 FLANGE ALUMINUM		Y2430A
	CODE-RLF ALUMINUM		Y2413A
2	GASKET - 2.5" HOSE COUPLING	1	V3190
3	COUPLING 2.5"NH	1	M307N
4	3/16" BALL - 302 STAINLESS STEEL	48	V2120
5	1/4-28 X 1/2 SOCKET SET SCREW	1	VT25-28SS500
6	BASE TILLER ALUMINUM	1	Y2410A
7	O-RING-233 2-7/8 ID X 1/8 C/S	2	VO-233
10	1/4-28 X 1/2 BUTTON HEAD CAP SCREW	2	VT25-28BH500
11	NAME LABEL: TORNADO MONITOR	1	Y2124
12	LABEL BRACKET	1	Y2120
13	3/8-24 X 3/8 DOG POINT	2	H515
14	WEAR DISC	2	Y4191
15	LOCKING BOLT	2	Y2318
16	1/4-20 X 1/2 BUTTON HEAD CAP SCREW	4	VT25-20BH500
17	LOCKING KNOB	2	Z245
20	3/8-16 X 1 SOCKET HEAD CAP SCREW	1	VT37-16SH1.0
21	THREAD ADAPTER 2.5"NH	1	Y2320ANJ
	THREAD ADAPTER 1.5"NH		Y2320ANF
	THREAD ADAPTER 2.5"BSP		Y2320ABJ
22	TILLER EXIT ELBOW ALUMINUM	1	Y2315A
23	TILLER BAR	1	Y2316
24	PEG	2	X362
25	3/8-16 X 1 3/4 STUD	1	VT37-16SD1.7
26	HANDLE BUSHING	1	Y2317
30	3/8-24 X 3/8 SOCKET SET SCREW CUP POINT	4	VT37-24SS375
31	BALL 5/16" TORLON	120	VB.312TO
32	1/4-28 X 3/16 SOCKET SET SCREW	2	VT25-28SS187
33	LOWER SECTION TILLER ALUM	1	Y2115A

9.2 TORNADO RC DRAWING & PARTS LIST

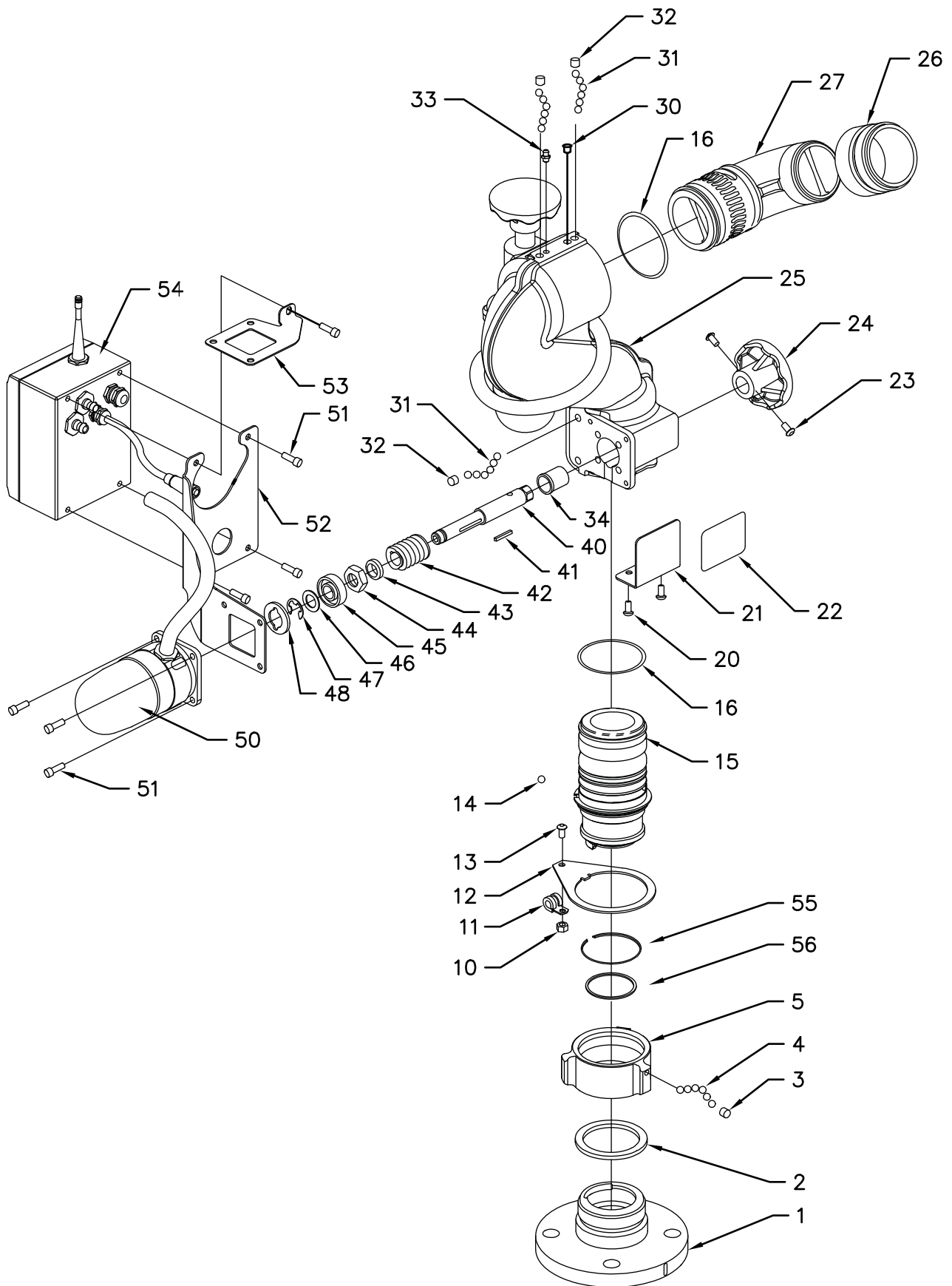

Fig 9.2
Tornado RC Exploded View

TORNADO RC PARTS LIST

#	DESCRIPTION	QTY	PART #
1	QUICK CONNECT 2.0"NPT FEMALE ALUMINUM	1	Y2420A
	QUICK CONNECT 2.5"NPT FEMALE ALUMINUM		Y2400A
	QUICK CONNECT 3.0"NPT FEMALE ALUMINUM		Y2403A
	QUICK CONNECT 2.0"BSP FEMALE ALUMINUM		Y2425A
	QUICK CONNECT 2.5"BSP FEMALE ALUMINUM		Y2405A
	QUICK CONNECT 2.5" ANSI 150 FLANGE ALUMINUM		Y2430A
	CODE-RLF ALUMINUM		Y2413A
2	GASKET - 2.5" HOSE COUPLING	1	V3190
3	1/4-28 X 1/2 SOCKET SET SCREW	1	VT25-28SS500
4	3/16" BALL - 302 STAINLESS STEEL	48	V2120
5	COUPLING 2.5"NH	1	M306
10	1/4-20 HEX NUT	1	VT25-20NT
11	3/8 LOOP CLAMP	1	Y4655
12	WIRE CLAMP BRACKET	1	Y2135
13	1/4-20 X 3/8 BUTTON HEAD CAP SCREW	1	VT25-20BH375
14	BALL 5/16" STAINLESS	1	VB.312
15	BASE - QUICK CONNECT ALUMINUM	1	Y2411A
16	O-RING-233 2-7/8 ID	2	VO-233
20	1/4-28 X 1/2 BUTTON HEAD CAP SCREW	2	VT25-28BH500
21	LABEL BRACKET	1	Y2120
22	NAME LABEL: TORNADO RC	1	Y2122
23	1/4-20 X 1/2 BUTTON HEAD CAP SCREW	4	VT25-20BH500
24	OVERRIDE KNOB	2	Z245
25	LOWER SECTION RC ALUMINUM	1	Y2110A
26	THREAD ADAPTER 2.5"NH MALE ALUMINUM	1	Y2320ANJ
	THREAD ADAPTER 1.5"NH MALE ALUMINUM		Y2320ANF
	THREAD ADAPTER 2.5"BSP MALE ALUMINUM		Y2320ABJ
27	EXIT ELBOW ALUMINUM	1	Y2310A
30	BLACK DOME PLUG	2	VM4124
31	BALL 5/16" TORLON	120	VB.312TO
32	3/8-24 X 3/8 SOCKET SET SCREW CUP POINT	4	VT37-24SS375
33	GREASE FITTING	2	VT25-28ZERK
34	HEADED BUSHING	2	Y4141
40	DRIVE SHAFT	2	Y4163
41	KEY; 1/8" X 1.00"	2	X225
42	WORM DOUBLE LEAD	2	Y2150
43	MALE THREADED BUSHING	2	Y2175
44	FEMALE THREADED BUSHING	2	Y2176
45	BEARING, CLASS C2	2	VM4252
46	WASHER	2	VW97X595-048
47	E-CLIP 5/8" EXTERNAL	2	VR4295
48	BEARING RETAINER	2	Y2160
50	MOTOR SUBASSEMBLY, SEE FIG 9.4	2	Y4951
51	1/4-28 X 5/8 SOCKET HEAD CAP SCREW	10	VT25-28SH625
52	CONTROL BOX BRACKET	1	Y2130
53	CONTROL BOX SUPPORT	1	Y2131
54	CONTROL BOX SUBASSEMBLY, SEE FIG 9.3	1	
55	SMALLEY RING	1	VR4310
56	QUAD RING	1	VOQ-4231

9.3 MONITOR CONTROL BOX

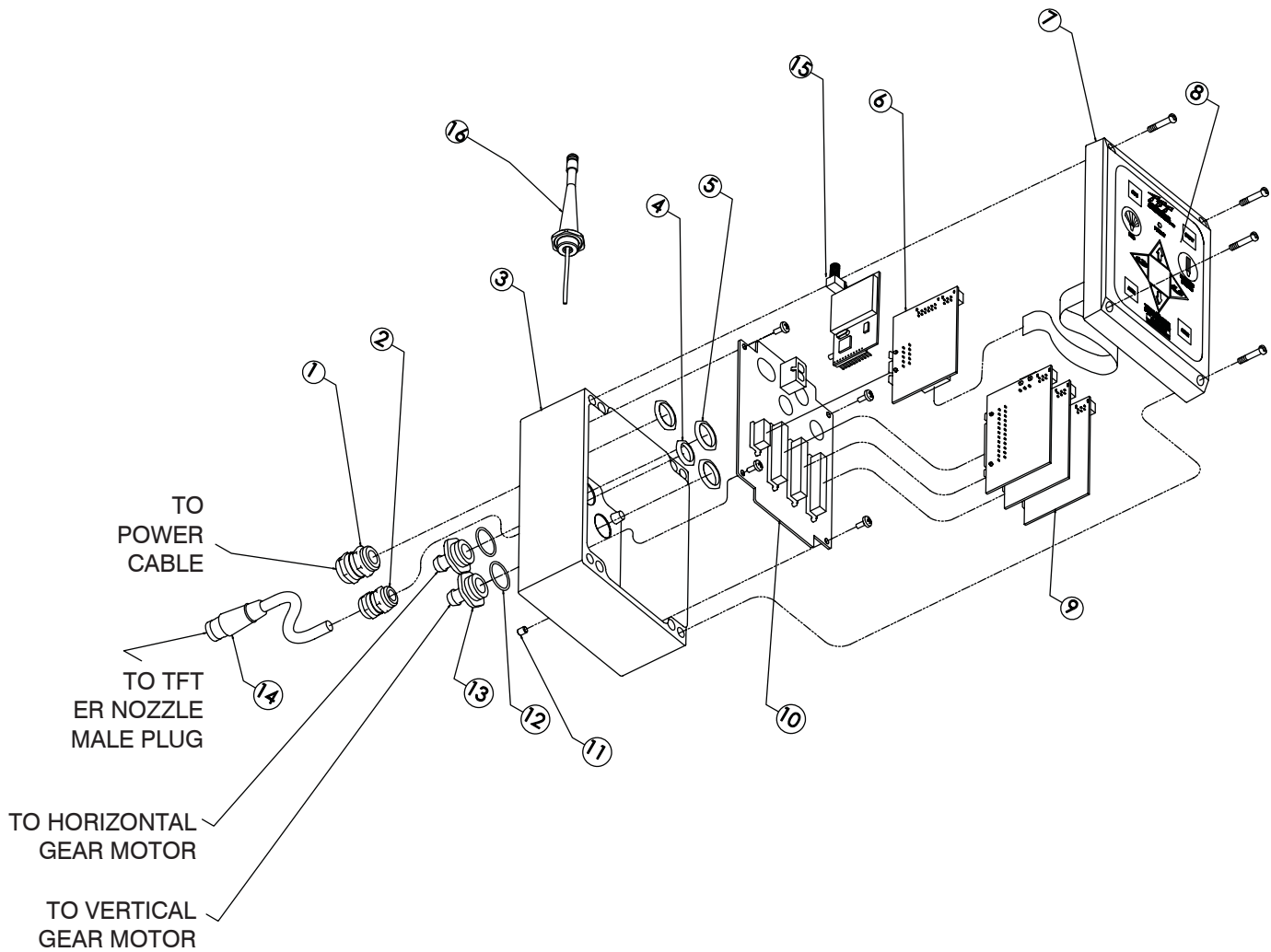

Fig 9.3 Monitor Control Box

TORNADO RC CONTROL BOX PARTS LIST

#	DESCRIPTION	QTY	PART #
1	CABLE FITTING PG11	1	Y5205
2	CABLE FITTING PG9	1	Y5245
3	ENCLOSURE - BOX	1	Y5115
4	LOCKNUT - PG9	1	Y5246
5	LOCKNUT - PG11	3	Y5206
6	BOARD - COMMUNICATION	1	Y5110-B
7	ENCLOSURE - LID	1	Y5115
8	CONTROL SWITCH PAD	1	Y5700
9	BOARD - MOTOR CONTROL	3	Y5100
10	BOARD - MAIN	1	Y5105
11	V10-32 x 1/4 SET SCREW	1	VT10Y32SS250
12	O-RING-018	2	VO-018
13	CONDUIT HOSE FITTING	2	Y5213
14	FEMALE PLUG - 6 POLE FOR TORNADO RC NOZZLE CONNECTION	10.0" TOTAL LENGTH USED 5.0" EXPOSED CABLE (not including plug)	Y5475
15	BOARD-OEM 900 MHZ RF MODULE (included with part YE-RF-900)	1	Y5710
16	ANTENNA W/FITTING	1	Y5881

9.4 MOTOR SUBASSEMBLY

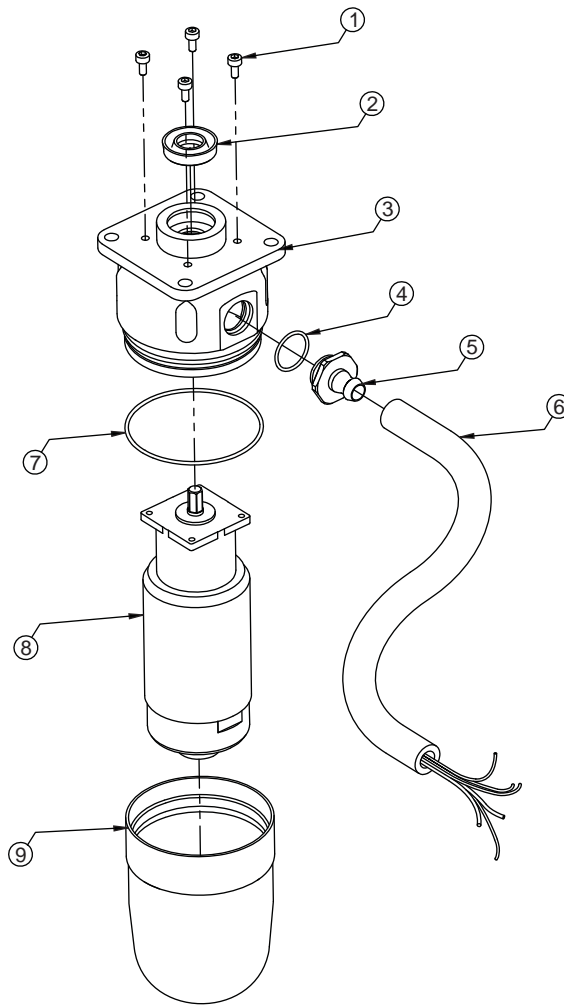

Fig 9.4
Motor Subassembly

TORNADO RC MOTOR SUBASSEMBLY PARTS LIST

#	DESCRIPTION	QTY	PART #
1	6-32 x 5/16 LONG SHCS WITH HEAD SEAL	4	VT06S32SH312
2	CUP SEAL 1.0625 x .5625 x 1/4	1	Y4620
3	MOTOR SOCKET, ANGLED FITTING	1	Y4617
4	O-RING-018, 3/4 ID 1/16 CS	1	VO-018
5	CONDUIT FITTING	1	Y5213
6	HOSE - 3/8" ID PUSH-LOK	1	Y5250
7	O-RING-038, 2-5/5 ID 1/16 CS	1	VO-038
8	GEAR MOTOR WITH ENCODER	1	Y4611
9	ENCLOSURE	1	Y4616

10.0 WARRANTY

Task Force Tips, Inc., Valparaiso, Indiana 46383-6940 ("TFT") warrants to the original purchaser of its Tornado and Tornado RC Monitor ("equipment"), and to anyone to whom it is transferred, that the equipment shall be free from defects in material and workmanship during the five (5) year period from the date of purchase.

TFT's obligation under this warranty is specifically limited to replacing or repairing the equipment (or its parts) which are shown by TFT's examination to be in a defective condition attributable to TFT. To qualify for this limited warranty, the claimant must return the equipment to TFT, at 2800 East Evans Avenue, Valparaiso, Indiana 46383-6940, within a reasonable time after discovery of the defect. TFT will examine the equipment. If TFT determines that there is a defect attributable to it, it will correct the problem within a reasonable time. If the equipment is covered by this limited warranty, TFT will assume the expenses of repair.

If any defect attributable to TFT under this limited warranty cannot be reasonably cured by repair or replacement, TFT may elect to refund the purchase price of the equipment, less reasonable depreciation, in complete discharge of its obligations under this limited warranty. If TFT makes this election, claimant shall return the equipment to TFT free and clear of any liens and encumbrances.

This is a limited warranty. The original purchaser of the equipment, any person to whom it is transferred, and any person who is an intended or unintended beneficiary of the equipment, shall not be entitled to recover from TFT any consequential or incidental damages for injury to person and/or property resulting from any defective equipment manufactured or assembled by TFT. It is agreed and understood that the price stated for the equipment is in part consideration for limiting TFT's liability. Some states do not allow the exclusion or limitation of incidental or consequential damages, so the above may not apply to you.

TFT shall have no obligation under this limited warranty if the equipment is, or has been, misused or neglected (including failure to provide reasonable maintenance) or if there have been accidents to the equipment or if it has been repaired or altered by someone else.

THIS IS A LIMITED EXPRESS WARRANTY ONLY. TFT EXPRESSLY DISCLAIMS WITH RESPECT TO THE EQUIPMENT ALL IMPLIED WARRANTIES OF MERCHANTABILITY AND ALL IMPLIED WARRANTIES OF FITNESS FOR A PARTICULAR PURPOSE. THERE IS NO WARRANTY OF ANY NATURE MADE BY TFT BEYOND THAT STATED IN THE DOCUMENT.

This limited warranty gives you specific legal rights, and you may also have other rights which vary from state to state.