



MANUAL: EF1 RC MONITOR

INSTRUCTIONS FOR INSTALLATION, SAFE OPERATION AND MAINTENANCE

⚠ DANGER

Understand manual and documents in additional literature before use. Operation of this device without understanding the manual and receiving proper training is a misuse of this equipment. Obtain safety information at www.tft.com/serial-number

This instruction manual is intended to familiarize firefighters and maintenance personnel with the operation, servicing and safety procedures associated with the EF1 RC Monitor series.

This manual should be kept available to all operating and maintenance personnel.

**See Section 3.2.2 for
Flow/Pressure
Operating Envelope**

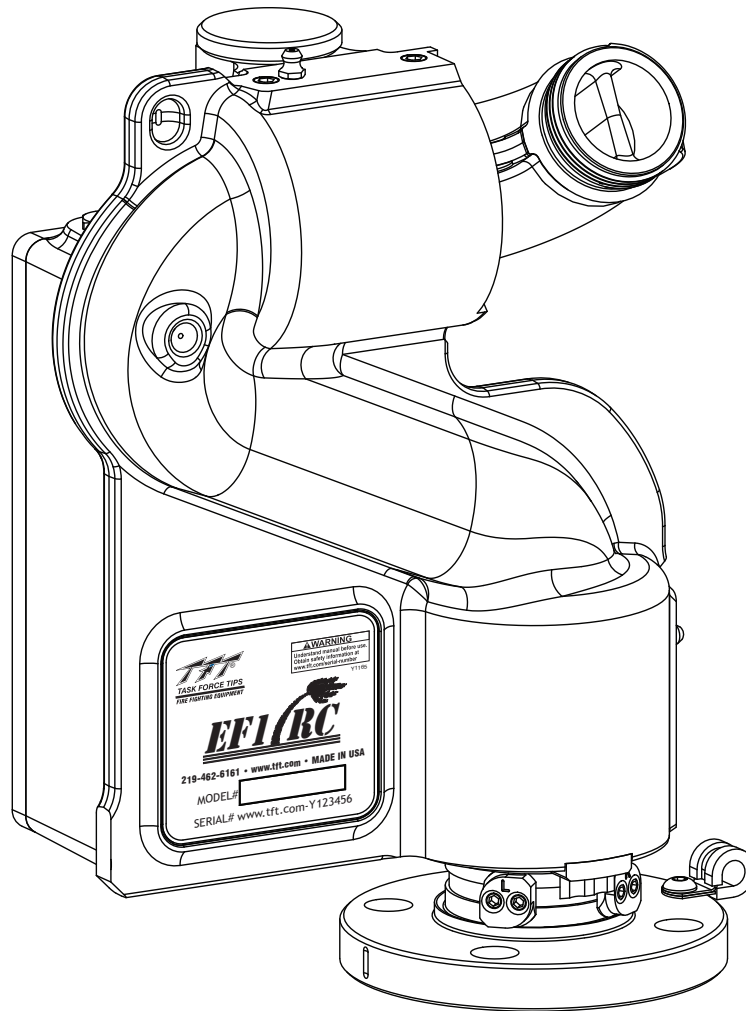

TASK FORCE TIPS, INC.
MADE IN USA • www.tft.com

3701 Innovation Way, Valparaiso, IN 46383-9327 USA
800-348-2686 • 219-462-6161 • Fax 219-464-7155

⚠ DANGER

PERSONAL RESPONSIBILITY CODE

The member companies of FEMSA that provide emergency response equipment and services want responders to know and understand the following:

1. Firefighting and Emergency Response are inherently dangerous activities requiring proper training in their hazards and the use of extreme caution at all times.
2. It is your responsibility to read and understand any user's instructions, including purpose and limitations, provided with any piece of equipment you may be called upon to use.
3. It is your responsibility to know that you have been properly trained in Firefighting and /or Emergency Response and in the use, precautions, and care of any equipment you may be called upon to use.
4. It is your responsibility to be in proper physical condition and to maintain the personal skill level required to operate any equipment you may be called upon to use.
5. It is your responsibility to know that your equipment is in operable condition and has been maintained in accordance with the manufacturer's instructions.
6. Failure to follow these guidelines may result in death, burns or other severe injury.



Fire and Emergency Manufactures and Service Association
P.O. Box 147, Lynnfield, MA 01940 • www.FEMSA.org

ADDITIONAL MANUALS

**MANUAL: Remote Control (RC)
Monitor Electrical Controls**

Supplemental Instructions for use with RC Monitor Manual

INSTRUCTIONS FOR INSTALLATION, SAFE OPERATION AND MAINTENANCE

⚠ DANGER

Understand manual before use. Operation of this device without understanding the manual and receiving proper training is a misuse of the equipment. Obtain safety information at www.tfi.com.

<p>SECTION 3.0 General Information and Specifications</p>	<p>SECTION 4.9 Digital Status Monitor Operator Station (Y4E-110)</p>
<p>SECTION 4.0 Electrical Controls Installation and Operation</p>	<p>SECTION 4.10 Monitor Communication Interface Control (Y4E-CAM)</p>
<p>SECTION 4.1 Monitor Mounted Operator Station</p>	<p>SECTION 4.11 Monitor Position Display (Y4E-01SP)</p>
<p>SECTION 4.2 Panel Mount Operator Station (Y4E-01P)</p>	<p>SECTION 4.12 Remote Auxiliary Function Interface Control (Y4E-01AUX)</p>
<p>SECTION 4.3 Panel Mount With Display Operator Station (Y4E-01D)</p>	<p>SECTION 4.13 Electric RC Monitor Aerial Truck Installation</p>
<p>SECTION 4.4 Ethernet Operator Station (Y4E-CT-01)</p>	<p>SECTION 4.14 Multiplex Interface Control (Y4E-CAM)</p>
<p>SECTION 4.5 Telnetted Operator Station With Display (Y4E-CT-01D)</p>	<p>SECTION 4.15 Ethernet Interface Control</p>
<p>SECTION 4.6 Operator Station (Y4E-01)</p>	<p>SECTION 4.16 Electric Nozzle Actuator</p>
<p>SECTION 4.7 Wireless Operator Station With Display (Y4E-01D)</p>	<p>SECTION 4.17 Valve Rite (Y4E-01V)</p>
<p>SECTION 4.8 Joystick Operator Station (Y4E-01J)</p>	<p>SECTION 5.0 Troubleshooting</p>

TASK FORCE TIPS, INC.
MADE IN USA • www.tfi.com

3707 Innovation Way, RI 02825-3227 USA
800-348-2888 • 219-462-6191 • FAX 219-464-7155

MANUAL: Remote Control (RC) Monitor Electrical Controls
LIY-500

Table Of Contents

- 1.0 MEANING OF SAFETY SIGNAL WORDS
- 2.0 SAFETY
- 3.0 GENERAL INFORMATION
 - 3.1 PART IDENTIFICATION
 - 3.2 SPECIFICATIONS
 - 3.2.1 MECHANICAL
 - 3.2.2 SAFE OPERATING ENVELOPE
 - 3.3 USE WITH SALT WATER
 - 3.4 INLETS AND OUTLET OPTIONS
 - 3.5 OVERALL DIMENSIONS
- 4.0 INSTALLATION
 - 4.1 STRUCTURAL REQUIREMENTS
 - 4.2 TRAVEL RANGES
 - 4.2.1 TRAVEL STOPS
 - 4.3 NOZZLE INSTALLATION
 - 4.4 PRESSURE GAGE
 - 4.5 DRAINING RESIDUAL WATER
- 5.0 SPRAY TRAJECTORY ADJUSTMENT
- 6.0 OPERATION OF RC MONITORS
- 7.0 RECOMMENDED PARK POSITION
 - 7.1 OVERRIDE HEX DRIVE
- 8.0 FLOW CHARACTERISTICS
 - 8.1 STACKED TIPS FLOW
 - 8.2 EF1 RC MONITOR FRICTION LOSS
- 9.0 DRAWINGS AND PARTS LIST
- 10.0 WARRANTY
- 11.0 MAINTENANCE
 - 11.1 LUBRICATION
 - 11.2 TROUBLESHOOTING
 - 11.3 REPAIR
- 12.0 ANSWERS TO YOUR QUESTIONS
- 13.0 INSPECTION CHECKLIST

1.0 MEANING OF SAFETY SIGNAL WORDS

A safety related message is identified by a safety alert symbol and a signal word to indicate the level of risk involved with a particular hazard. Per ANSI standard Z535-2011, the definitions of the four signal words are as follows:



DANGER indicates a hazardous situation which, if not avoided, will result in death or serious injury.



WARNING indicates a hazardous situation which, if not avoided, could result in death or serious injury.



CAUTION indicates a potentially hazardous situation which, if not avoided, could result in minor or moderate injury.



NOTICE is used to address practices not related to physical injury.

2.0 SAFETY

The operation of this monitor can be dangerous. The following must be observed at all times.



An inadequate supply of nozzle pressure and/or flow will cause an ineffective stream and can result in injury, death, or loss of property. See flow graphs or call 800-348-2686 for assistance.



Injury or death may occur by attempting to use a damaged monitor. Before using the monitor, inspect it for damage resulting from, but not limited to:

- Failure to drain monitor followed by exposure to freezing conditions.
See section DRAINING RESIDUAL WATER for instructions.
- Exposure of monitor to temperatures in excess of 160°F (71°C).
- Missing parts, physical abuse, exposure to severe chemicals.
- Deformed or cracked flanges damaged as a result of improper installation.
 - Excessive bolt torque
 - Wrong tightening sequence



Injury can result from an inadequately supported monitor. The monitor mount must be capable of supporting 145 lbs (66 kg) of nozzle reaction force.



The stream exiting a monitor is very powerful and capable of causing injury and property damage. Make sure the monitor is securely attached to the base and pointing in a safe direction before water to the monitor is turned on. Use care in directing the stream.



The monitor may be damaged if frozen while containing sufficient amounts of water. Such damage may be difficult to detect visually and can lead to possible injury or death. Any time the monitor is subject to possible damage from freezing, it must be hydrostatically tested by qualified personnel before being considered safe for use.



Keep hands and fingers away from moving parts of the oscillating unit when water is flowing. There are moving parts that can pinch fingers and hands.



This equipment is intended for use by trained personnel for firefighting. Their use for other purposes may involve hazards not addressed by this manual. Seek appropriate guidance and training to reduce risk of injury.



The electric monitor may be remotely operated. The electric drives are current limited but may still produce enough force to cause injury. Keep hands and fingers away from pinch points on the monitor.



Do not use the manual override while the electric controls are in operation. The electric drives produce enough torque to cause injury.



Exceeding the operating envelope of the monitor can result in injury. Observe safe operation by staying within the published limits.



On many vehicle installations, the monitor is the highest point on the apparatus. Be sure there is sufficient clearance to safely pass under any doors or overhead obstructions. Always check parked position of the monitor before moving.



To prevent mechanical damage, do not drop or throw equipment.

3.0 GENERAL INFORMATION

The EF1 RC monitor is extremely compact, yet it has a large 1-½ inch waterway, capable of flowing up to 200 gpm, making it the ideal forestry bumper turret. Waterway with turning vane has only 15 psi (1.3 bar) friction loss at 200 gpm (760 l/min). Elevation range is 90° above horizontal to 45° below. Horizontal travel is 270° (135° either side of a center position). Field changeable horizontal travel stops are factory set to give 180° (90° either side of a center position). Designed for 12 VDC or 24 VDC operation, selection is automatic. The motor control circuits use position encoders and current limiting to protect the drive train at the ends of travel. Unit has waterproof factory installed plug on power wire for easy removal or reinstallation. Electric drives and control box are waterproof. Main waterway made from hardcoat anodized ANSI 356-T6 aluminum. Silver powder coat finish. Various inlets are available.

3.1 PART IDENTIFICATION

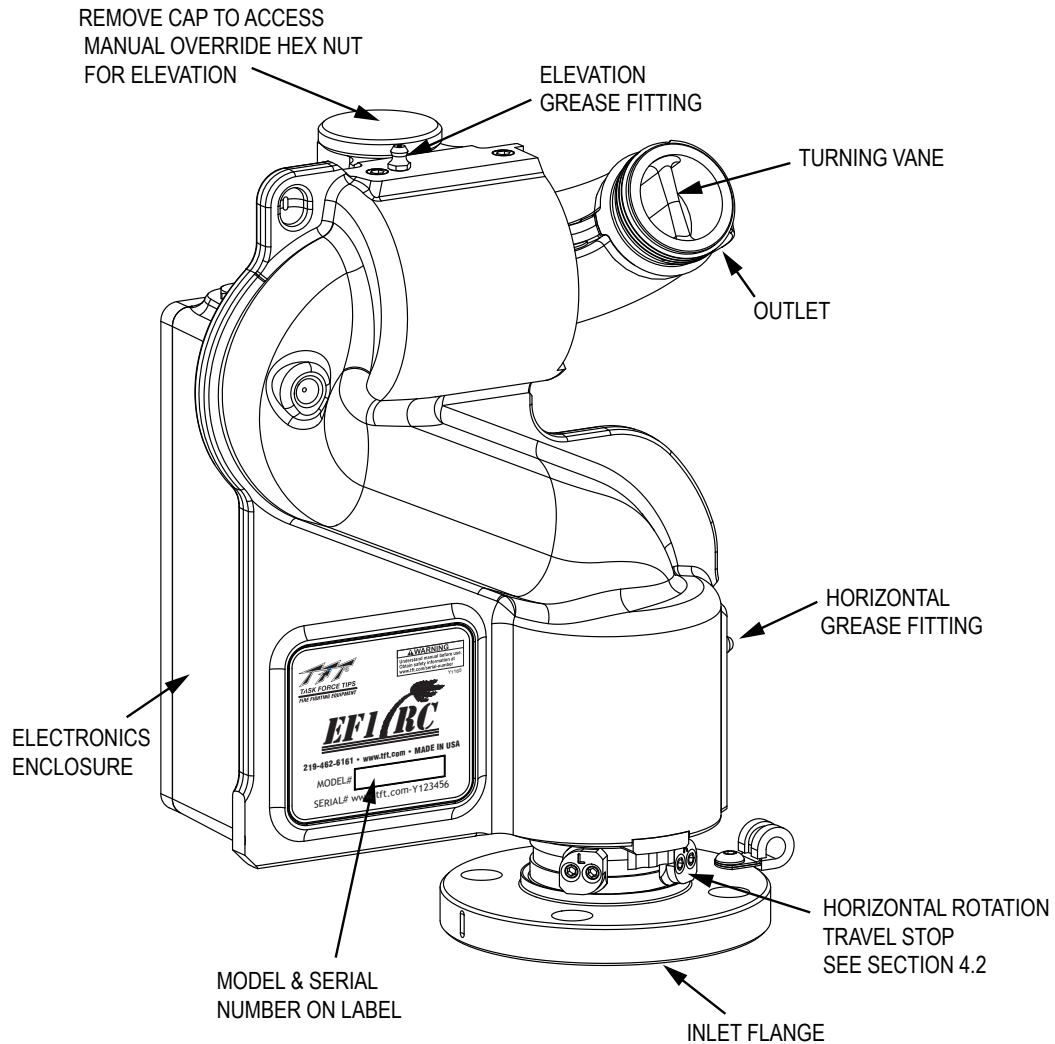

Fig. 3.1
EF1 RC Monitor Part Identification

3.2 SPECIFICATIONS

3.2.1 MECHANICAL

	Electric	
	US	METRIC
Weight	14.2 lbs	6.5 kg
Min. Flow Area 1.5" Inlet	1.77 in ²	11.4 cm ²
Min. Flow Area 2.0" Inlet	3.14 in ²	20.3 cm ²
Max Flow	See figure 3.2.2	
Max Operating Pressure	200 psi	14 bar
Horizontal Travel Range	270° (135° left and right)	
Materials Used	ANSI A356.0-T6 Aluminum, Stainless	
Maximum Torque Elevation	26 ft•lbs	35 n•m
Maximum Torque Horizontal	26 ft•lbs	35 n•m
Speed Elevation	33 deg/sec	
Speed Horizontal	33 deg/sec	

3.2.2 SAFE OPERATING ENVELOPE

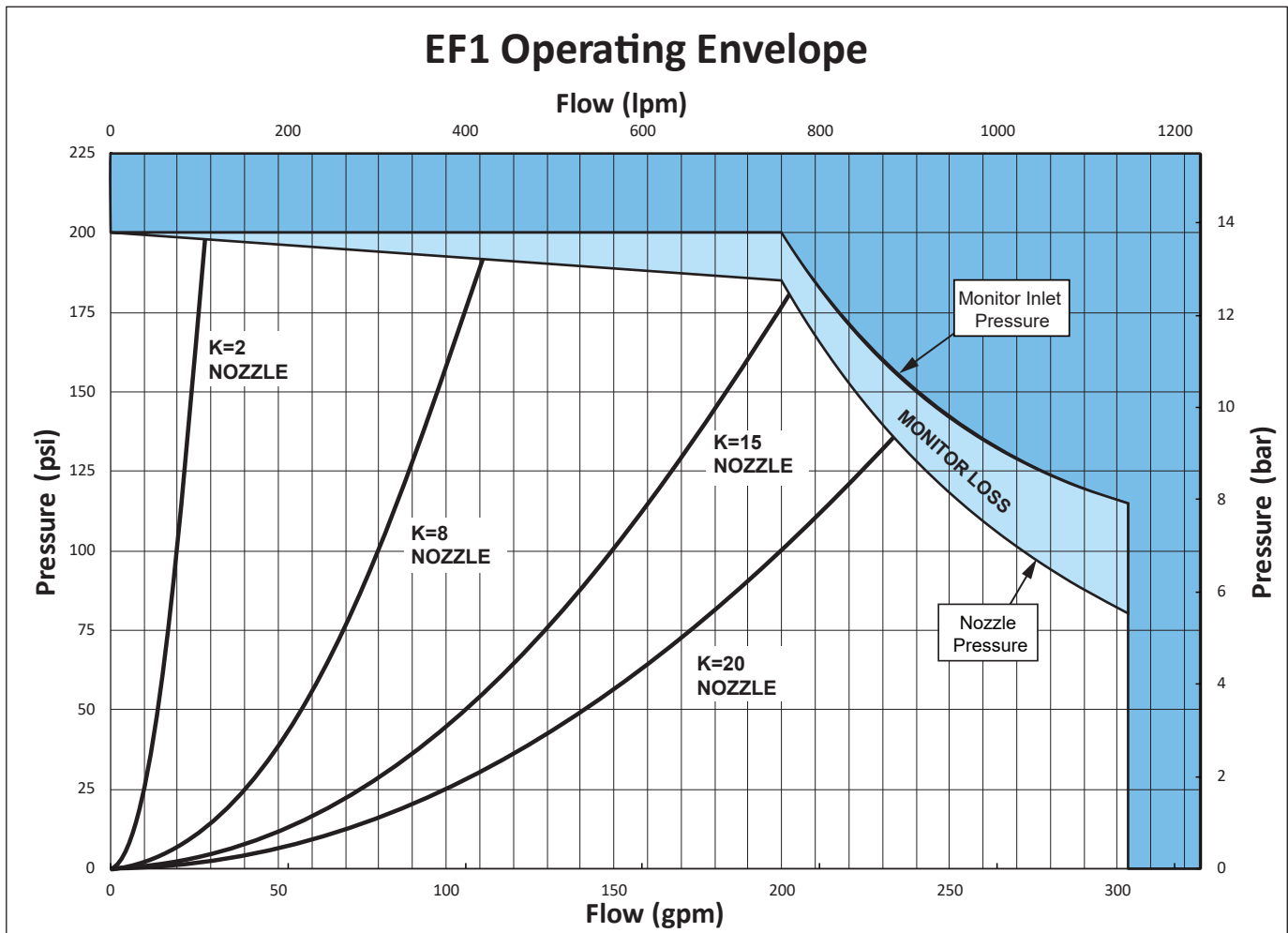

- Nozzle A flows 20 gpm (80 l/min) at 100 psi (7 bar), K factor = 2
- Nozzle B flows 80 gpm (300 l/min) at 100 psi (7 bar), K factor = 8
- Nozzle C flows 150 gpm (570 l/min) at 100 psi (7 bar), K factor = 15
- Nozzle D flows 200 gpm (760 l/min) at 100 psi (7 bar), K factor = 20

Figure 3.2.2
Safe Operating Envelope

3.3 USE WITH SALT WATER

Use with salt water is permissible provided the monitor is thoroughly cleaned with fresh water after each use. The service life of the monitor may be shortened due to the effects of corrosion and is not covered under warranty.

3.4 INLET AND OUTLET OPTIONS

Available inlets and outlets are shown below and should be specified at time of order.

Note: Outlet thread options are machined into elbow.

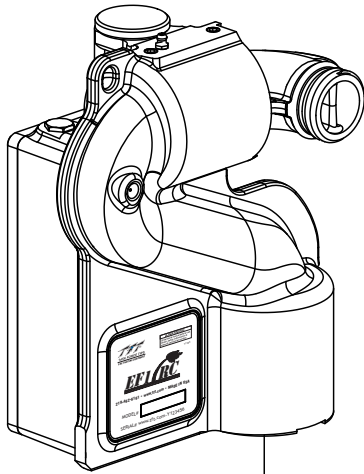

OUTLET OPTIONS		
OPTION #	THREAD	ELBOW
1	1.5" NH MALE	Y1311ANF
2	1.5" NPSH MALE	Y1311AIF
3	1.5" BSP MALE	Y1311ABF

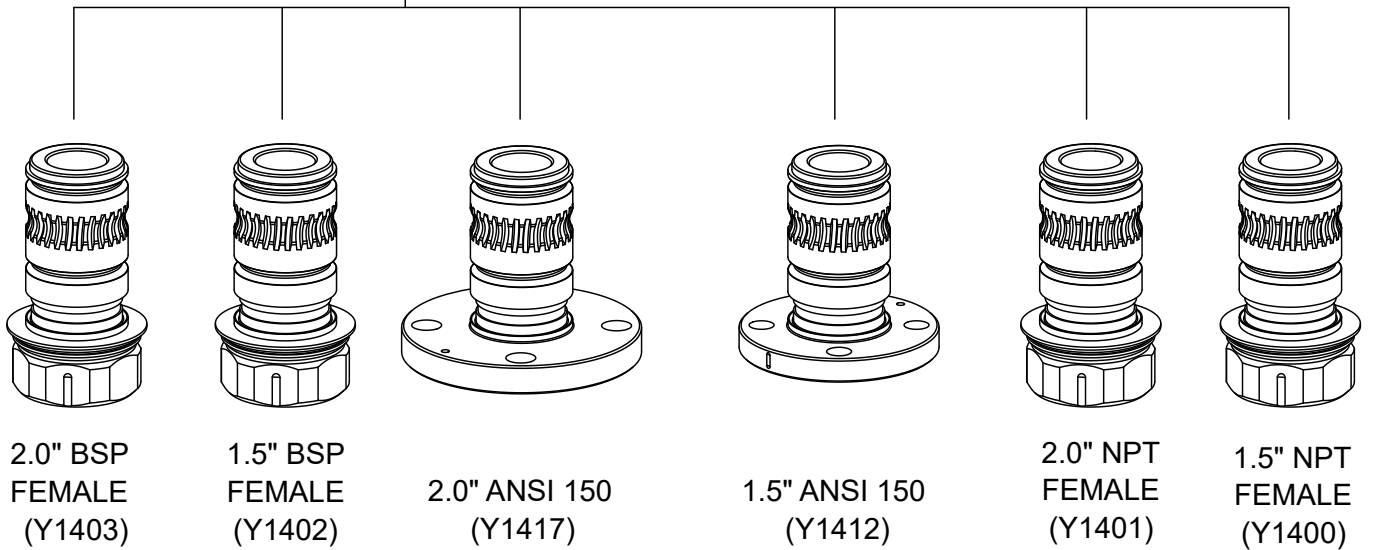

Fig 3.4a
Inlets and Outlets

INLET OPTION	Weight	
2.0" BSP FEMALE (Y1403)	2.1 lb	0.95 kg
1.5" BSP FEMALE (Y1402)	2.1 lb	0.95 kg
2.0" ANSI 150 (Y1417)	3.0 lb	1.4 kg
1.5" ANSI 150 (Y1412)	2.2 lb	1.0 kg
2.0" NPT FEMALE (Y1401)	2.1 lb	0.95 kg
1.5" NPT FEMALE (Y1400)	2.1 lb	0.95 kg

Figure 3.4b
Inlet Weight

3.5 OVERALL DIMENSIONS

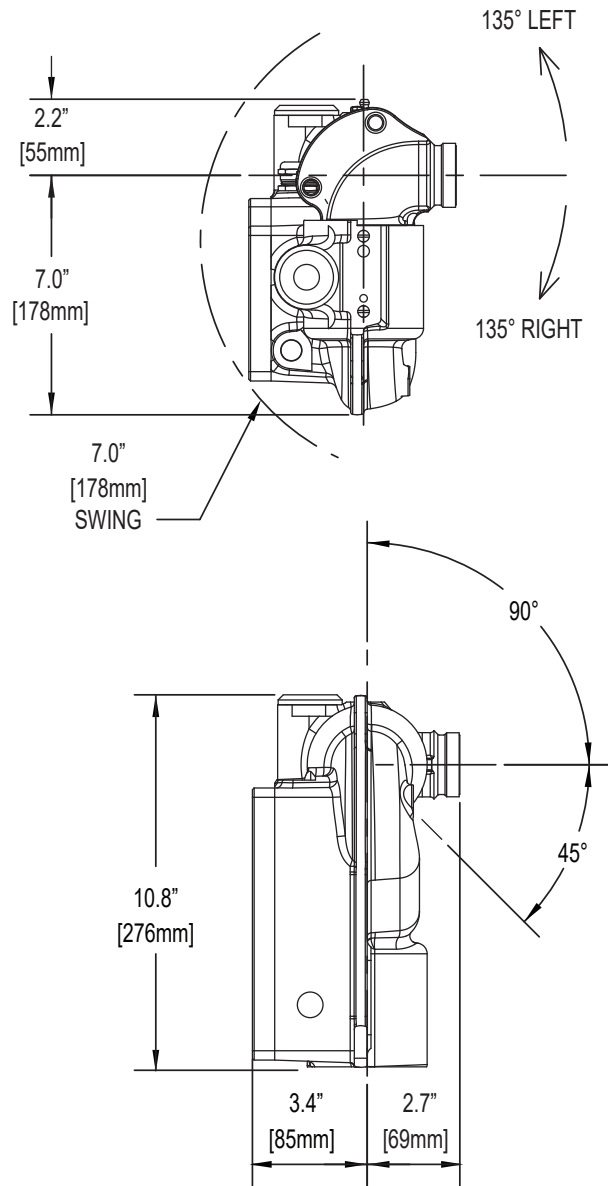

Fig 3.5a
EF1 RC Monitor Dimensions

INLET OPTION	Additional Overall Height	
2.0" BSP FEMALE (Y1403)	2.7 in	69 mm
1.5" BSP FEMALE (Y1402)	2.7 in	69 mm
2.0" ANSI 150 (Y1417)	1.8 in	45 mm
1.5" ANSI 150 (Y1412)	1.7 in	43 mm
2.0" NPT FEMALE (Y1401)	2.7 in	69 mm
1.5" NPT FEMALE (Y1400)	2.7 in	69 mm

Fig 3.5b
Inlet Heights

4.0 INSTALLATION

See Remote Control (RC) Monitor Electrical Controls Supplemental Instructions (LIY-500) For RC monitor.

4.1 STRUCTURAL REQUIREMENTS

The structure that the EF1 RC Monitor is mounted to must withstand the internal pressure of the monitor as well as shear and bending forces due to nozzle reaction. Nozzle reaction can be as high as 150 lbs (70 kg) (200 gpm at 200 psi).

For flanged connections the use of flat flanges without raised faces is recommended. Use a ring gasket as defined in ASME 16.21 or ISO 7483. Tighten flange bolts in an alternating sequence as shown in figure 4.1. Tighten sequentially each bolt or stud three times with 30%, then 60%, and finally 100% of the specified torque. Tighten to 76-80 ft-lb (100-110 Newton-Meters).

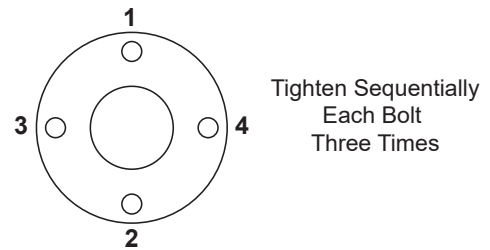

Fig 4.1
Flange Bolt Tightening Sequence

FLANGE TYPE	OUTSIDE DIAMETER		THICKNESS		BOLT HOLE CIRCLE		# OF BOLTS	SIZE OF BOLTS		TORQUE ON BOLTS	
	in	mm	in	mm	in	mm		in	mm	ft-lb	N-m
1.5 ANSI 150	5	127	0.63	16	3.88	98.4	4	1/2	13	20-40	27-54
2.0 ANSI 150	6	152.4	0.75	19	4.75	120.7	4	5/8	16	40-70	54-95

4.2 TRAVEL RANGES

The EF1 RC Monitor is available with various inlet fittings. These Inlet Adaptors must be oriented upon installation so the EF1 RC will point in the desired direction. Figure 3.4A shows examples of Inlet Adaptors. Travel ranges relative to the Straight Ahead Reference Mark are shown in Figure 4.2. Figure 4.2.1 gives the location of the travel stops.

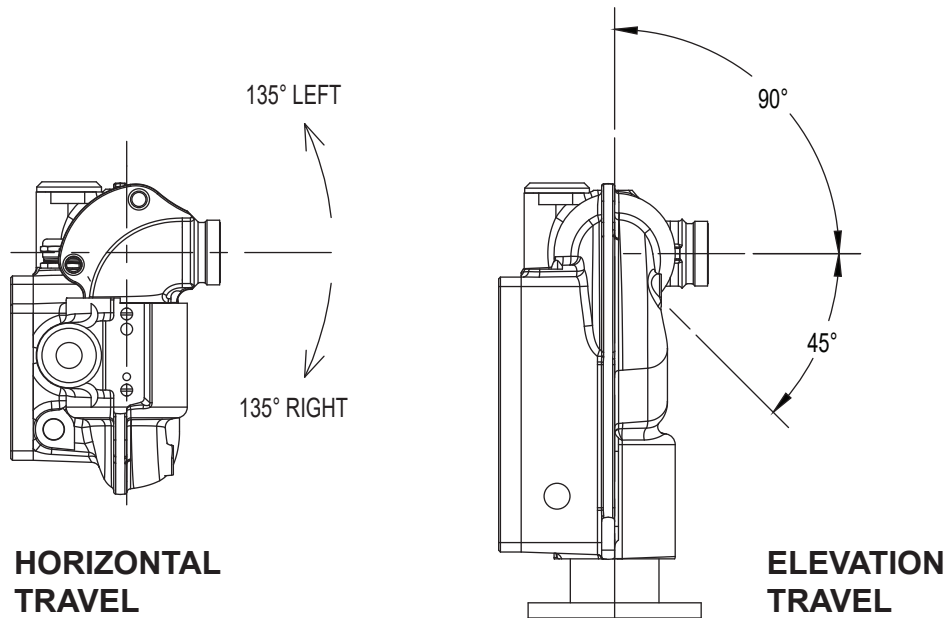
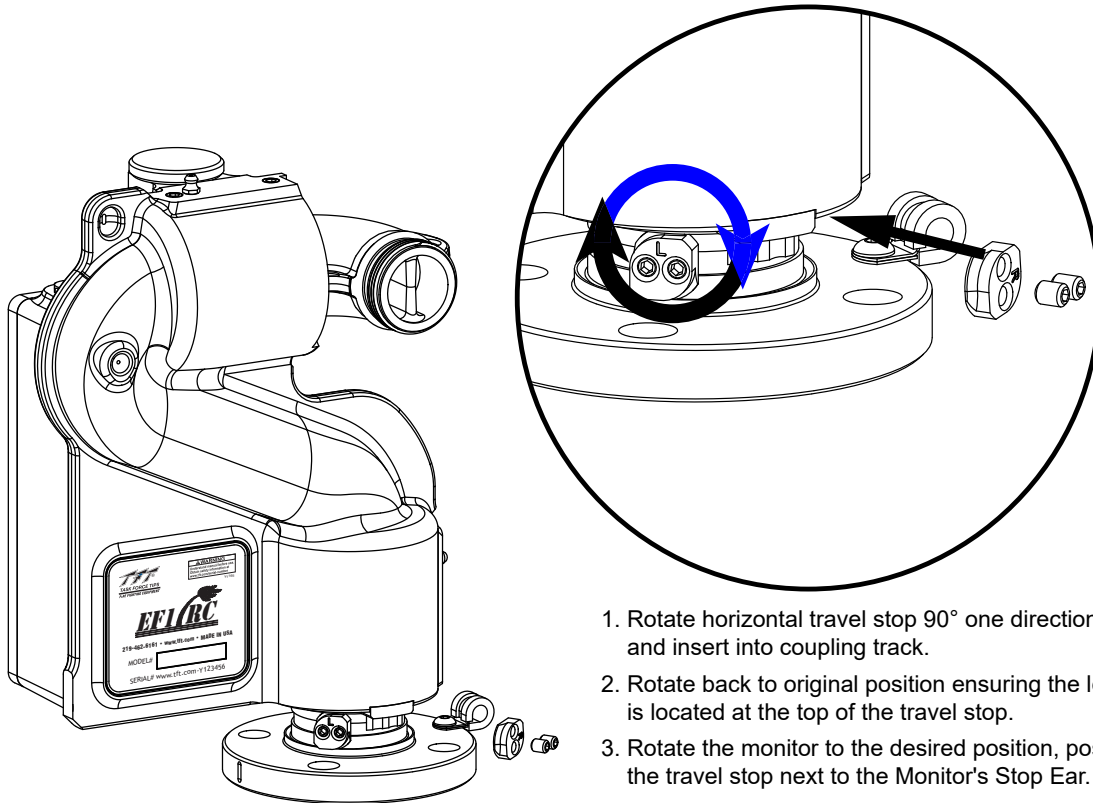

Fig 4.2 Travel Ranges Relative to Straight Ahead Reference Mark

4.2.1 TRAVEL STOPS

Vertical Travel Stops are cast into the elbow of the monitor. Instructions on how to install horizontal travel stops are shown below.



1. Rotate horizontal travel stop 90° one direction and insert into coupling track.
2. Rotate back to original position ensuring the letter is located at the top of the travel stop.
3. Rotate the monitor to the desired position, position the travel stop next to the Monitor's Stop Ear.
4. Tighten set screws to lock the travel stop position.

Fig 4.2.1 Travel Stops

4.3 NOZZLE INSTALLATION

The nozzle is simply screwed onto the monitor's exit threads.

CAUTION

The nozzle threads must match the threads of the monitor elbow in both size and type. Mismatched or damaged threads may cause the nozzle to leak or uncouple under pressure and could cause injury.

CAUTION

Do not connect aluminum to brass or brass to aluminum. Dissimilar metals coupled together can cause galvanic corrosion that will freeze the threaded joint or cause complete loss of thread engagement. If dissimilar metals must be coupled together, the effects of corrosion can be greatly delayed by various coatings on the metal such as powder paint, hard anodizing, or silicone grease.

4.4 PRESSURE GAGE

There is a raised boss on the front of the monitor. This raised boss is not machined from the factory but may be drilled and tapped for 1/4 NPT threads if a pressure gage is desired on the monitor.

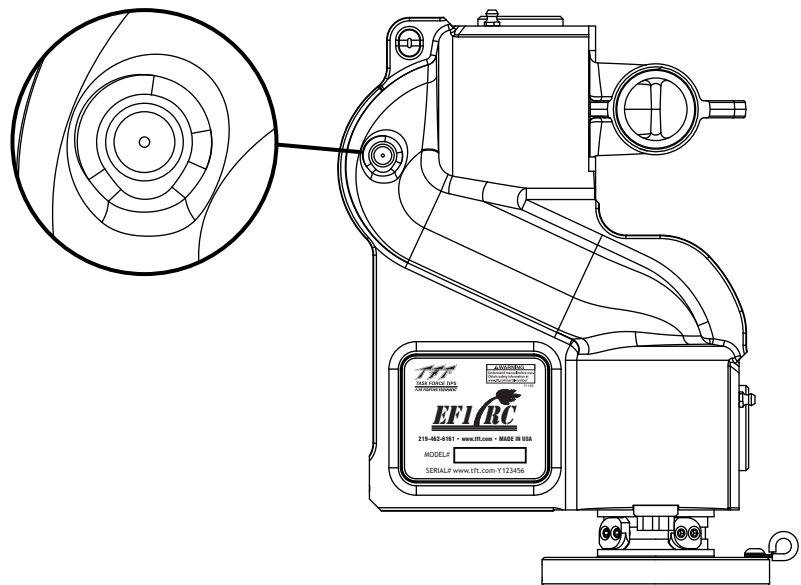

Fig 4.4 Pressure Gage

4.5 DRAINING RESIDUAL WATER

There is no drain on the EF1 RC Monitor itself. A drain valve should be installed on the piping to which the monitor is attached.

⚠ WARNING All monitors, valves, and standpipes exposed to freezing conditions must be drained immediately following use to prevent damage. To drain a standpipe, a drainage port must be opened underground below the frost depth to keep water out of the standpipe until the next use.

5.0 SPRAY TRAJECTORY ADJUSTMENT

⚠ CAUTION Injury can result from the monitor changing direction due to an off center nozzle reaction. An off center nozzle reaction may be caused by debris in the nozzle causing an asymmetrical stream.

6.0 OPERATION OF RC MONITORS

See Remote Control (RC) Monitor Electrical Controls Supplemental Instructions LIY-500 for operation of the EF1 RC Monitor.

7.0 RECOMMENDED PARK POSITION

For truck mounted applications it is recommended that the monitor be parked in a position such that the monitor's nozzle rests against a bracket or support surface. If a support surface is not available, run the elevation against one of its travel stops to take some of the backlash out of the gear drive. This will minimize bouncing of the nozzle when the apparatus is traveling. Always be sure the monitor is properly parked before moving the truck and know the overall height to avoid damage from overhead obstructions such as doors or bridges.

See Remote Control (RC) Monitor Electrical Controls Supplemental Instructions (LIY-500) for information on programming, OSCILLATE and PARK position of the EF1 RC monitor.

7.1 OVERRIDE HEX DRIVE

In the event of electrical system failure on the monitor or fire truck, the EF1 RC Monitor is factory supplied with a hex drive so a 1/4" hex wrench may be used for manual override. Pry the dust caps off from the horizontal or vertical shafts to access the hex drives.

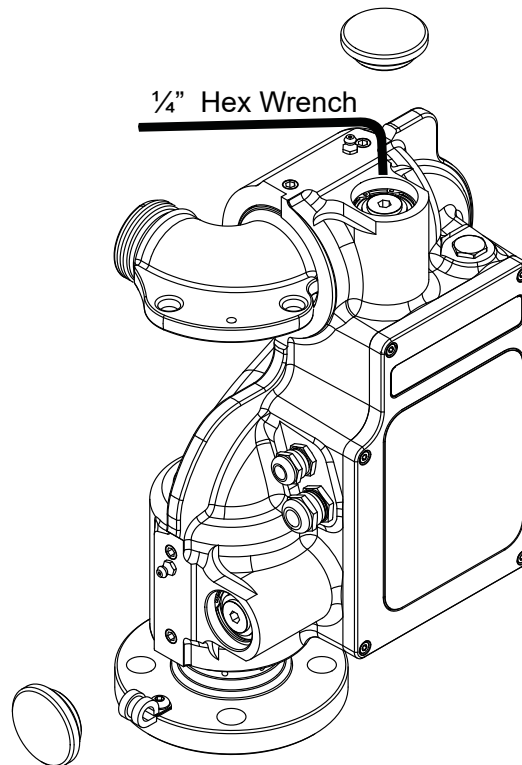

Fig 7.1
Wrenching Hexes on Drive Shafts

8.0 FLOW CHARACTERISTICS

8.1 STACKED TIPS FLOW

NOZZLE DIAMETER	NOZZLE INLET PRESSURE									
	50 PSI		80 PSI		100 PSI		150 PSI		175 PSI	
	FLOW (GPM)	REACTION (LBS)	FLOW (GPM)	REACTION (LBS)	FLOW (GPM)	REACTION (LBS)	FLOW (GPM)	REACTION (LBS)	FLOW (GPM)	REACTION (LBS)
1/2 INCH	53	20	66	31	74	39	91	59	98	69
5/8 INCH	82	31	104	49	116	61	142	92	153	107
3/4 INCH	118	44	149	71	167	88	205	132	221	155

NOZZLE DIAMETER	NOZZLE INLET PRESSURE									
	4 BAR		6 BAR		8 BAR		10 BAR		12 BAR	
	FLOW (l/min)	REACTION (KG)	FLOW (l/min)	REACTION (KG)	FLOW (l/min)	REACTION (KG)	FLOW (l/min)	REACTION (KG)	FLOW (l/min)	REACTION (KG)
12 MM	190	9	230	14	270	18	300	23	330	28
16 MM	340	16	420	25	480	33	540	41	590	49
19 MM	480	23	590	35	680	46	760	58	830	69

Fig. 8.1
Stacked Tips Flow Table

8.2 EF1 MONITOR FRICTION LOSS

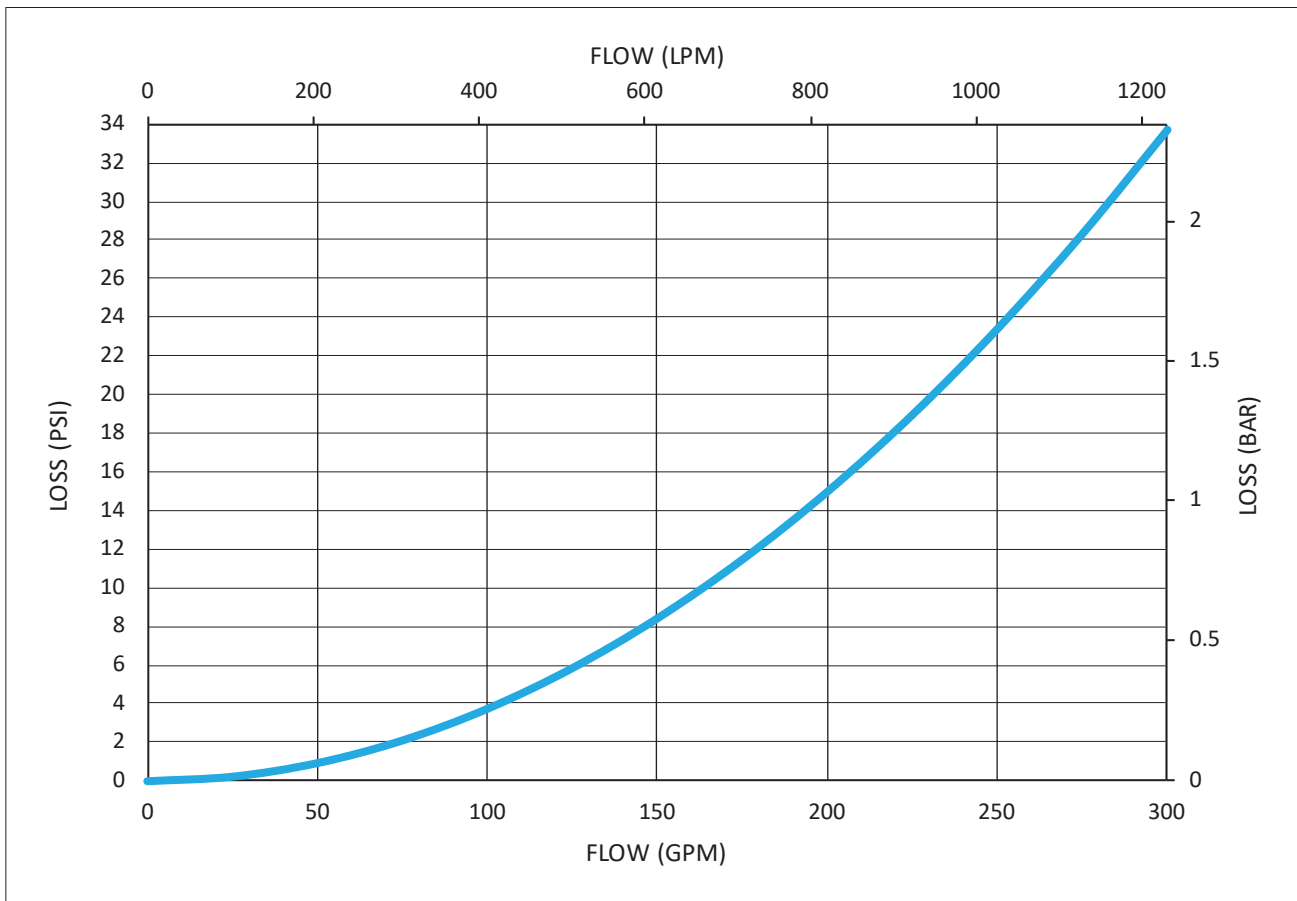
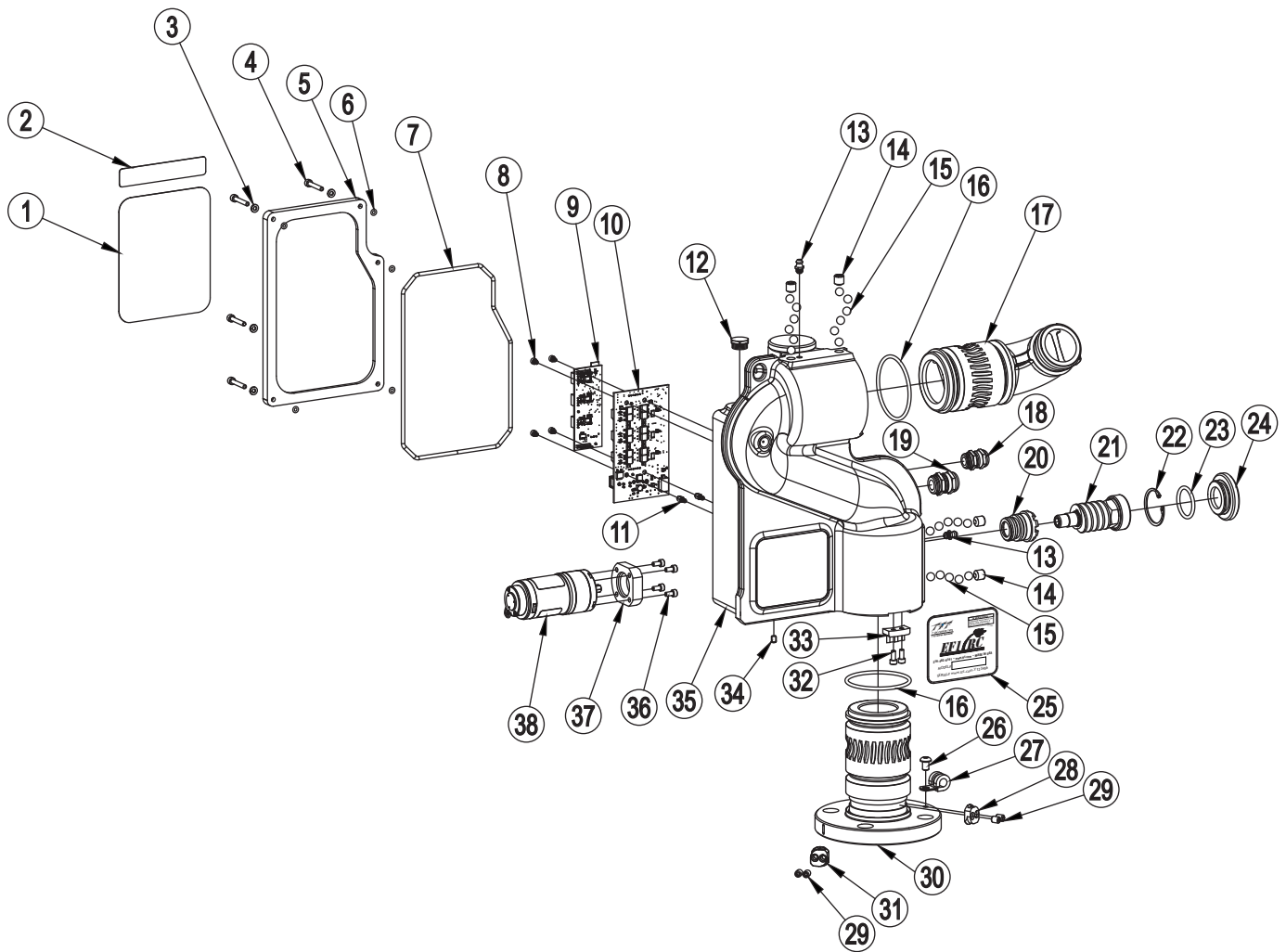

Fig 8.2
Friction Loss

9.0 DRAWING & PARTS LIST



ITEM #	DESCRIPTION	QTY	PART #
1	BRAND LABEL	1	Y5703
2	WARNING LABEL	1	ZB1069
3	O-RING-006	5	VO-006
4	M4-0.7 X 25MM SOCKET HEAD CAP SCREW	5	VTM4-0.7SH25
5	ENCLOSURE LID	1	Y1116
6	O-RING-006	1	VO-006
7	O-RING-262	1	VO-262
8	6-32 X 3/16 SOCKET HEAD CAP SCREW	4	VT06-32SH188
9	SIGNAL AND COMMUNICATION BOARD	1	Y5010
10	MOTOR CONTROL BOARD	1	Y5000
11	CIRCUIT BOARD STANDOFF	2	Y5533
12	HEX PLUG	1	Y5248
13	GREASE FITTING 1/4-28	2	VT25-28ZERK
14	3/8-24 X 3/8 SOCKET SET SCREW	4	VT37-24SS375
15	BALL 5/16" TORLON	100	VB.312TO
16	O-RING-229	2	VO-229
17	ELBOW	1	See Fig 3.4
18	STRAIN RELIEF	1	Y5245
19	STRAIN RELIEF	1	Y5205

ITEM #	DESCRIPTION	QTY	PART #
20	MOTOR MOUNT RETAINER	2	Y1910
21	DRIVE SHAFT SUBASSEMBLY	2	Y1915
22	SNAP RING	2	VR4220
23	O-RING-215	2	VO-215
24	CAP	2	Y1161
25	NAME LABEL	1	Y1165
26	1/4-20 X 3/8 BUTTON HEAD CAP SCREW	1	VT25-20BH375
27	3/8 LOOP CLAMP	1	Y4655
28	TRAVEL STOP RIGHT	1	Y1414
29	1/4-20 X 5/16 SOCKET SET SCREW	4	VT25-20SS312
30	RIGID BASE 1.5" ANSI 150	1	See Fig 3.4
31	TRAVEL STOP LEFT	1	Y1413
32	8-32 X 3/8 SOCKET HEAD CAP SCREW	2	VT08-32SH375
33	STOP EAR	1	Y1415
34	10-32 X 1/4 SET SCREW	1	VT10Y32SS250
35	LOWER SECTION	1	Y1110
36	M4-0.7 X 8MM SOCKET HEAD CAP SCREW	8	VTM4-0.7SH8
37	MOTOR MOUNT	2	Y1164
38	GEAR MOTOR	2	Y6000

10.0 WARRANTY

Task Force Tips, Inc., 3701 Innovation Way, Valparaiso, Indiana 46383-9327 USA ("TFT") warrants to the original purchaser of its nozzles and other equipment ("equipment"), and to anyone to whom it is transferred, that the equipment shall be free from defects in material and workmanship during the five (5) year period from the date of purchase.

TFT's obligation under this warranty is specifically limited to replacing or repairing the equipment (or its parts) which are shown by TFT's examination to be in a defective condition attributable to TFT. To qualify for this limited warranty, the claimant must return the equipment to TFT, at 3701 Innovation Way, Valparaiso, Indiana 46383-9327 USA, within a reasonable time after discovery of the defect. TFT will examine the equipment. If TFT determines that there is a defect attributable to it, it will correct the problem within a reasonable time. If the equipment is covered by this limited warranty, TFT will assume the expenses of repair.

If any defect attributable to TFT under this limited warranty cannot be reasonably cured by repair or replacement, TFT may elect to refund the purchase price of the equipment, less reasonable depreciation, in complete discharge of its obligations under this limited warranty. If TFT makes this election, claimant shall return the equipment to TFT free and clear of any liens and encumbrances.

This is a limited warranty. The original purchaser of the equipment, any person to whom it is transferred, and any person who is an intended or unintended beneficiary of the equipment, shall not be entitled to recover from TFT any consequential or incidental damages for injury to person and/or property resulting from any defective equipment manufactured or assembled by TFT. It is agreed and understood that the price stated for the equipment is in part consideration for limiting TFT's liability. Some states or countries do not allow the exclusion or limitation of incidental or consequential damages, so the above may not apply to you.

TFT shall have no obligation under this limited warranty if the equipment is, or has been, misused or neglected (including failure to provide reasonable maintenance) or if there have been accidents to the equipment or if it has been repaired or altered by someone else.

THIS IS A LIMITED EXPRESS WARRANTY ONLY. TFT EXPRESSLY DISCLAIMS WITH RESPECT TO THE EQUIPMENT ALL IMPLIED WARRANTIES OF MERCHANTABILITY AND ALL IMPLIED WARRANTIES OF FITNESS FOR A PARTICULAR PURPOSE. THERE IS NO WARRANTY OF ANY NATURE MADE BY TFT BEYOND THAT STATED IN THE DOCUMENT.

This limited warranty gives you specific legal rights, and you may also have other rights which vary from state to state.

11.0 MAINTENANCE

The EF1 RC Monitor requires little maintenance. The unit should be kept clean and free of dirt by rinsing with water after each use. Any inoperable or damaged parts should be repaired or replaced before placing the unit in service. Equipment can be returned to the factory for service and/or testing.



Any alterations to the monitor and its markings could diminish safety and constitutes a misuse of this product

11.1 LUBRICATION

The EF1 monitor generally should not require greasing. In the event that the operation becomes stiff grease may be applied to the horizontal rotation and elevation worm gears. See figure 3.1 for grease port locations. Use medium viscosity automotive chassis grease. Apply only enough grease to restore normal operation. If normal operation is not restored by greasing than inspect for other causes of stiff operation.

Note: Do not over pump grease. The monitor’s greased areas lead to large chambers that could trap several pounds of grease before becoming visible.

11.2 TROUBLESHOOTING

SYMPTOM	POSSIBLE CAUSE	REMEDY
Leaks	Debris or damage in seal area	Clean out debris or replace damaged parts
Elevation Binding	Debris or damage to elevation drive parts	Clean out debris or replace damaged parts
	Lack of lubricant	Grease, see section 11.1
	May be electrical related	See trouble shooting section of Electronics Manual LIY-500
Horizontal Rotation Binding	Debris or damage to horizontal drive parts	Clean out debris or replace damaged parts
	Lack of lubricant	Grease, see section 11.1
	May be electrical related	See trouble shooting section of Electronics Manual LIY-500

11.3 REPAIR

Factory service is available with repair time seldom exceeding one day in our facility. Factory serviced appliances are repaired by experienced technicians to original specifications, fully tested, and promptly returned.

Repair parts and service procedures are available for those wishing to perform their own repairs. Task Force Tips assumes no liability for damage to equipment or injury to personnel that is a result of user service.

For additional information on care, maintenance, and testing, refer to: NFPA 1962: Standard for the Care, Use, Inspection, Service Testing, and Replacement of Fire Hose, Couplings, Nozzles, and Fire Hose Appliances, 2013 Edition

12.0 ANSWERS TO YOUR QUESTIONS

We appreciate the opportunity of serving you and making your job easier. If you have any problems or questions, our toll-free “Hydraulics Hotline”, 800-348-2686, is normally available to you 24 hours a day, 7 days a week.

13.0 INSPECTION CHECKLIST

BEFORE EACH USE, appliances must be inspected to this checklist:

- All valves (if so equipped) open and close fully and smoothly
- Waterway is clear of obstructions
- There is no damage to any thread or other connection
- All locks and hold-down devices work properly
- The pressure setting on the relief valve (if so equipped) is set correctly
- Gaskets are in good repair
- There is no obvious damage such as missing, broken, or loose parts
- There is no damage to the appliance that could impair safe operation (e.g. dents, cracks, corrosion, or other defects)
- All swiveling elements rotate freely
- Nozzle is securely attached

BEFORE BEING PLACED BACK IN SERVICE, appliances must be inspected to this list:

1. All valves open and close smoothly and fully
2. The waterway is clear of obstructions
3. There is no damage to any thread or other type connection
4. The pressure setting of the relief valve, if any, is set correctly
5. All locks and hold-down devices work properly
6. Internal gaskets are in accordance with NFPA 1962 (2013) Section 7.2
7. There is no damage to the appliance that could impair safe operation (e.g. dents, cracks, corrosion, or other defects)
8. All swiveling connections rotate freely
9. There are no missing parts or components
10. The marking for maximum operating pressure is visible
11. There are no missing, broken, or worn lugs on couplings

NFPA 1962: Standard for the care, use, inspection, service testing, and replacement of fire hose, couplings, nozzles and fire hose appliances. (2013 ed., Section 6.2.1). Quincy, MA: National Fire Protection Agency.



Any monitor failing any part of the inspection checklist is unsafe and must have the problem corrected before use. Operating a monitor that fails any of the above inspections is a misuse of this equipment.