



MANUAL: MONSOON MONITOR SERIES

See LIY-500 Remote Control (RC) Monitor Electrical Controls
Supplemental Instructions For Use With Monsoon RC Models

INSTRUCTIONS FOR INSTALLATION, SAFE OPERATION AND MAINTENANCE

⚠ DANGER

Understand manual before use. Operation of this device without understanding the manual and receiving proper training is a misuse of this equipment. Obtain safety information at www.tft.com/serial-number

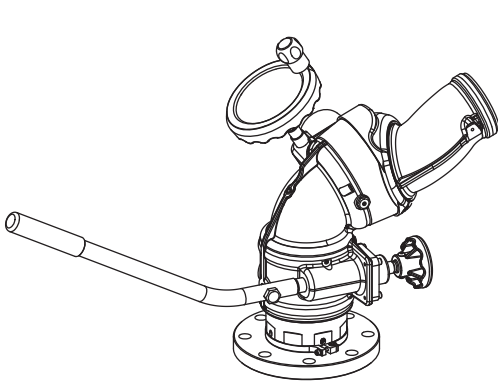

Tiller
3.5" Discharge

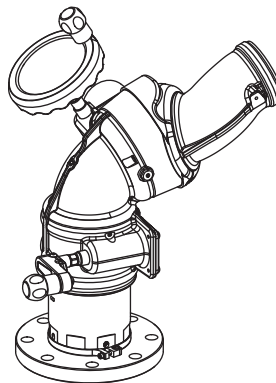

Dual Handwheel
3.5" Discharge

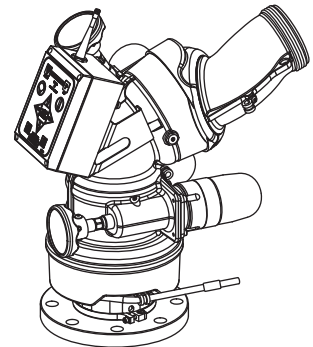

Remote Control
3.5" Discharge

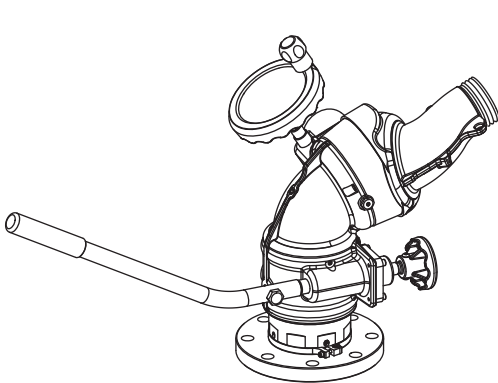

Tiller
2.5" Discharge

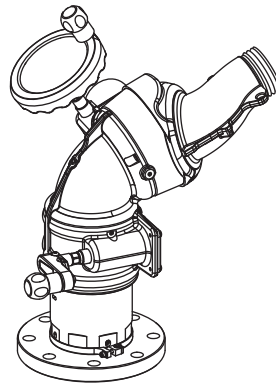

Dual Handwheel
2.5" Discharge

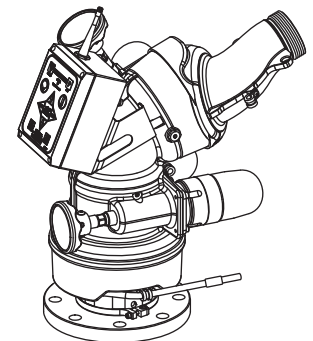

Remote Control
2.5" Discharge



See Section 3.1 for Flow/Pressure Operating Envelope

TASK FORCE TIPS LLC
MADE IN USA • tft.com

3701 Innovation Way, Valparaiso, IN 46383-9327 USA
800-348-2686 • 219-462-6161 • Fax 219-464-7155

DANGER

PERSONAL RESPONSIBILITY CODE

The member companies of FEMSA that provide emergency response equipment and services want responders to know and understand the following:

1. Firefighting and Emergency Response are inherently dangerous activities requiring proper training in their hazards and the use of extreme caution at all times.
2. It is your responsibility to read and understand any user's instructions, including purpose and limitations, provided with any piece of equipment you may be called upon to use.
3. It is your responsibility to know that you have been properly trained in Firefighting and /or Emergency Response and in the use, precautions, and care of any equipment you may be called upon to use.
4. It is your responsibility to be in proper physical condition and to maintain the personal skill level required to operate any equipment you may be called upon to use.
5. It is your responsibility to know that your equipment is in operable condition and has been maintained in accordance with the manufacturer's instructions.
6. Failure to follow these guidelines may result in death, burns or other severe injury.



Fire and Emergency Manufacturers and Service Association
P.O. Box 147, Lynnfield, MA 01940 • www.FEMSA.org

Table Of Contents

1.0	Meaning of Safety Signal Words.....	3
2.0	Safety	3
3.0	General Information	4-11
3.1	Mechanical Specifications	
3.2	Part Identification and Models	
3.3	Inlets and Outlets	
3.3.1	Inlet Options and Additional Height	
3.3.1.1	Flanges	
3.3.1.2	NPT Female	
3.3.1.3	BSP Male	
3.3.1.4	Mating Products	
3.3.2	Outlet Options	
3.4	Overall Dimensions	
4.0	Installation	11-16
4.1	Structural Requirements for Monitor Mounting	
4.2	Inlet Mounting and Travel Ranges	
4.2.1	Two Piece Clamp Rotational Lock Installation Instructions	
4.2.2	Extend-a-Gun RC Installation	
4.2.3	Horizontal Rotation Travel Stops	
4.2.4	Elevation Travel Stops	
4.3	Nozzle Installation	
4.4	Pressure Gage Port	
4.5	Handle Installation Instructions	
4.6	Drain	
4.7	Ladder Monitor Installation	
5.0	Operation	16-17
5.1	Horizontal Rotation Control	
5.2	Elevation Control	
5.3	Tiller Bar Model	
5.4	Recommended Park Position	
5.5	Override Knobs	
6.0	Flows and Pressures.....	17-24
6.1	Stacked Tips Flow and Reach	
6.1.1	YST-4NM Flow and Reach	
6.1.2	MST-4NJ Flow and Reach	
6.2	Automatic Masterstream Nozzles	
6.3	Monsoon Monitor Friction Loss	
6.4	Stream Straighteners	
6.4.1	Stream Straighteners with Stacked Tips	
6.4.2	Stream Straighteners with Fog Nozzles	
7.0	Monsoon Drawings Parts List	26-32
7.1	Manual Monsoon Drawing & Parts List	
7.2	Monsoon RC Drawing & Parts List	
7.3	Monitor Control Box	
7.4	Monitor Motor Enclosure	
8.0	Warranty	34
9.0	Maintenance and Inspection	34
9.1	Lubrication	
10.0	Troubleshooting.....	35
11.0	Repair	35
12.0	Answers to Your Questions	35
13.0	Inspection Checklist	36

1.0 MEANING OF SAFETY SIGNAL WORDS

A safety related message is identified by a safety alert symbol and a signal word to indicate the level of risk involved with a particular hazard. Per ANSI standard Z535.6-2011, the definitions of the four signal words are as follows:



DANGER indicates a hazardous situation which, if not avoided, will result in death or serious injury.



WARNING indicates a hazardous situation which, if not avoided, could result in death or serious injury.



CAUTION indicates a potentially hazardous situation which, if not avoided, could result in minor or moderate injury.



NOTICE is used to address practices not related to physical injury.

2.0 SAFETY

The operation of this monitor can be dangerous. The following must be observed at all times.



Injury or death may occur by attempting to use a damaged monitor. Before using the monitor inspect it for damage resulting from:

- Failure to drain monitor followed by exposure to freezing conditions
- Exposure of monitor to temperatures in excess of 160 degrees F
- Structural damage caused by over-pressurization
- Missing parts, physical abuse, exposure to severe chemicals
- Deformed or cracked flanges damaged as a result of improper installation
 - Excessive bolt torque
 - Wrong tightening sequence



Injury can result from an inadequately supported monitor. The monitor mount must be capable of supporting 1200 lbs (550 kg) of nozzle reaction force.



The stream exiting a monitor is very powerful and capable of causing injury and property damage. Make sure the monitor is securely attached to the base and pointing in a safe direction before water to the monitor is turned on. Use care in directing the stream.



The monitor may be damaged if frozen while containing sufficient amounts of water. Such damage may be difficult to detect visually and can lead to possible injury or death. Any time the monitor is subject to possible damage from freezing, it must be hydrostatically tested by qualified personnel before being considered safe for use.



The electric Monsoon RC may be remotely operated. The electric drives are current limited but may still produce enough force to cause injury. Keep hands and fingers away from pinch points on the monitor.



Do not use the manual override knobs while the electric controls are in operation. The electric drives produce enough torque to cause injury.



Maximum flow and pressure is shown in Figure 3.1.1 Operating Envelope. Damage or injury may result if the monitor is operated beyond these limits.



On many vehicle installations, the monitor is the highest point on the apparatus. Be sure there is sufficient clearance to safely pass under any doors or overhead obstructions. Always check parked position of the monitor before moving.



Use with salt water is permissible provided the monitor is thoroughly cleaned with fresh water after each use. The service life of the monitor may be shortened due to the effects of corrosion and is not covered under warranty.

3.0 GENERAL INFORMATION

The Monsoon Monitor is a manually operated monitor designed for master stream flows. Maximum operating pressure is 200 psi (14 bar). Unique patented segmented waterway allows water to make very few turns as it travels through the monitor resulting in low friction loss and a far reaching effective stream. Elevation range is 90 degrees above horizontal to 45 degrees below. Field changeable elevation travel stops at 45 degrees above, 30 degrees above, and 30 degrees below horizontal. The manual model has 360 degree continuous horizontal rotation with field changeable stops at 45, 90, and 135 degrees either side of a center position. Available with various inlet flanges and threaded fittings. Inlet also made for direct connection to TFT's electric Extend-A-Gun RC3 or RC4. Main waterway made from hardcoat anodized ANSI 356.0-T6 aluminum. Silver powder coat finish inside and out.

The Monsoon RC is an electric remote controlled monitor that has all the benefits of the Monsoon monitor with the addition of powered operation. Designed for auto sensing 12 VDC or 24 VDC operation. The Monsoon RC comes with a factory installed control panel mounted on the monitor for controlling horizontal rotation, elevation, and nozzle pattern. The motor control circuits are factory installed on the monitor and use position encoders and current limiting to protect the drive train at the ends of travel. Unit comes with ultra-flexing robotics cable already wired to the monitor so installation effort is minimized. Power wire has only four conductors (two for power and two for communications) further easing installation effort. Power wire is enclosed in a unique wire guide that allows 450 degrees of horizontal travel (225 degrees either side of a center position) which is far more reliable than slip rings or coil cords. Knobs for manual override are provided on the horizontal rotation and elevation drive. TFT's nozzles plug into the factory installed nozzle power wire. Electric drives and control box are waterproof.

3.1 MECHANICAL SPECIFICATIONS

	Manual		Electric	
	US	METRIC	US	METRIC
Weight	25 lbs	11.4 kg	37 lbs	16.8 kg
Min. Flow Area 4" Inlet	8.3 in ²	24.5 cm ²	8.3 in ²	24.5 cm ²
Min. Flow Area 3" Inlet	7.07 in ²	45.6 cm ²	7.07 in ²	45.6 cm ²
Max Flow	See Figures 3.1.1 and 3.1.2			
Max Operating Pressure	200 psi	14 bar	200 psi	14 bar
Materials Used	ANSI A356.0-T6 Aluminum, Stainless, Nylon			
Maximum Torque Elevation			80 ft•lbs	110 n•m
Maximum Torque Horizontal			60 ft•lbs	80 n•m
Speed Elevation	6 deg/sec			
Speed Horizontal	12 deg/sec			

*See LIY-500 Remote Control (RC) Monitor Supplemental Instructions for electrical specifications.

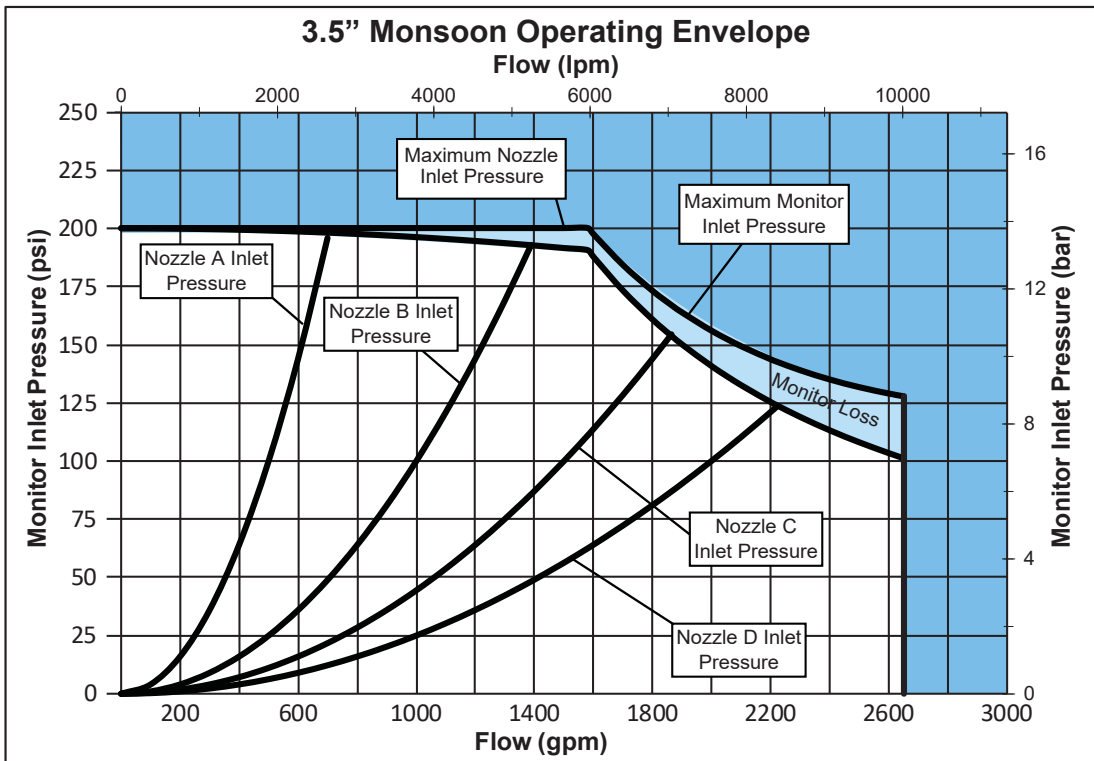

Nozzle A flows 500 gpm (1900 l/min) at 100 psi (7 bar), K factor = 50
 Nozzle B flows 1000 gpm (3800 l/min) at 100 psi (7 bar), K factor = 100
 Nozzle C flows 1500 gpm (5700 l/min) at 100 psi (7 bar), K factor = 150
 Nozzle D flows 2000 gpm (7600 l/min) at 100 psi (7 bar), K factor = 200

Fig. 3.1.1
Monsoon Operating Envelope

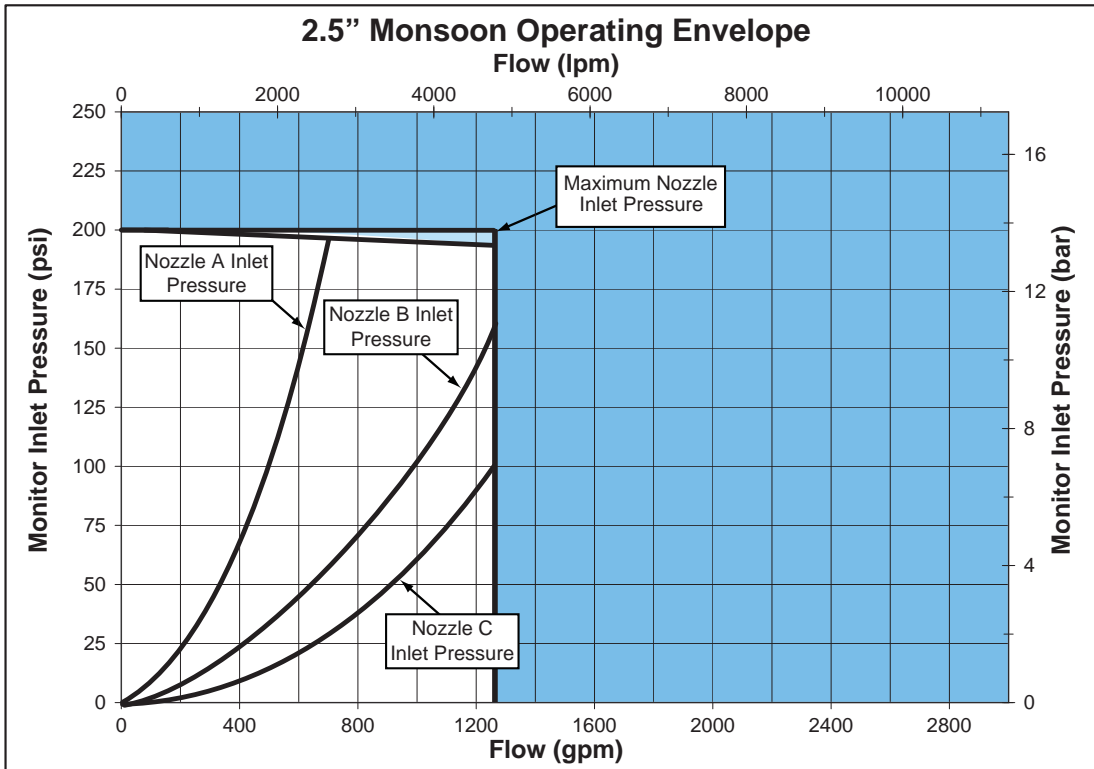

Nozzle A flows 500 gpm (1900 l/min) at 100 psi (7 bar), K factor = 50
 Nozzle B flows 1000 gpm (3800 l/min) at 100 psi (7 bar), K factor = 100
 Nozzle C flows 1250 gpm (4800 l/min) at 100 psi (7 bar), K factor = 150

Fig. 3.1.2
Monsoon Operating Envelope

3.2 PART IDENTIFICATION AND MODELS

The Monsoon Monitor comes in manual and electric remote controlled models. Manual models are available with either handwheel control on both axis or a tiller bar model that uses a tiller bar to control horizontal rotation. Electric remote control models are available in a standard model (suitable for on top of pumpers), a Ladder model and a Platform model. The Ladder or Platform model has a smaller swing radius and has horizontal travel stops factory installed at 90° left and right (180° total). The various models of Monsoon monitors are shown in figures 3.2A, 3.2B, 3.2C and 3.2D. The monitor mounted control station on the standard remote controlled model is shown in figure 3.2E.

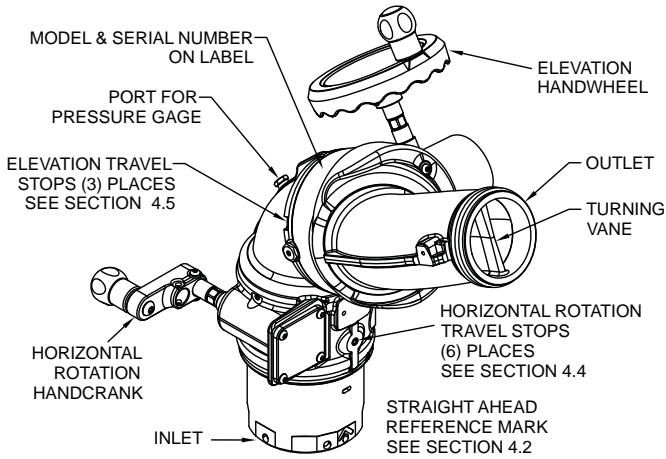

Figure 3.2A
Manual Handwheel Monsoon Monitor

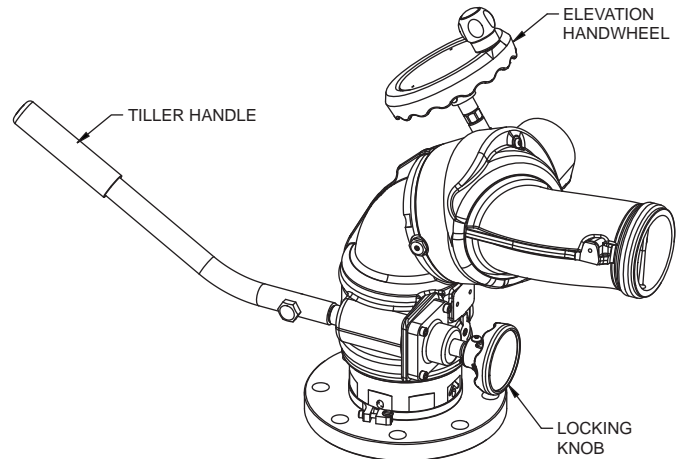

Figure 3.2B
Manual Tiller Bar Monsoon Monitor

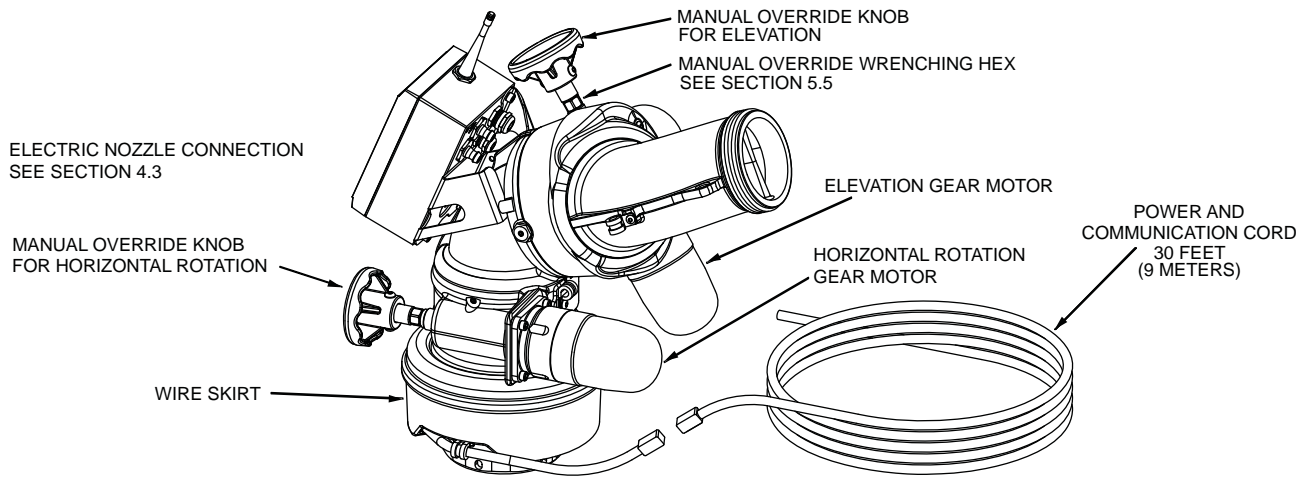

Figure 3.2C
Monsoon RC Monitor

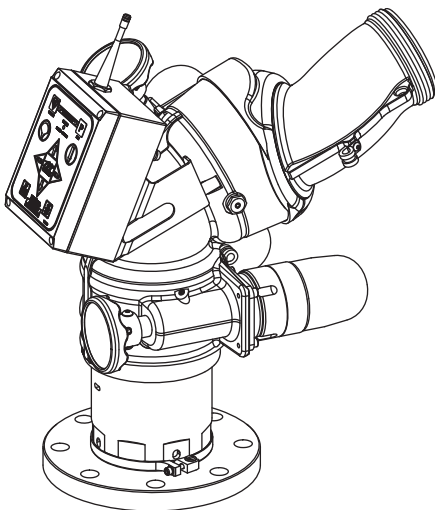

Figure 3.2D
Monsoon RC for Ladders or Platforms

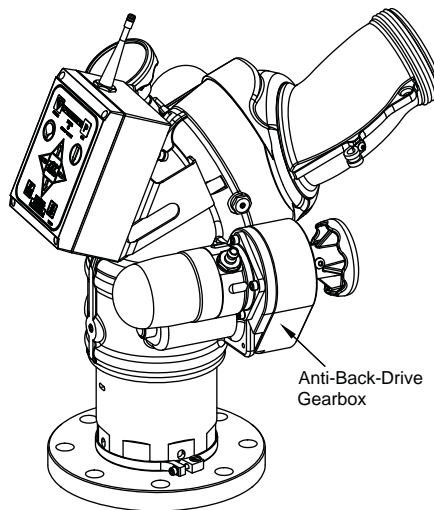

Figure 3.2E
Monsoon RC for Ladders

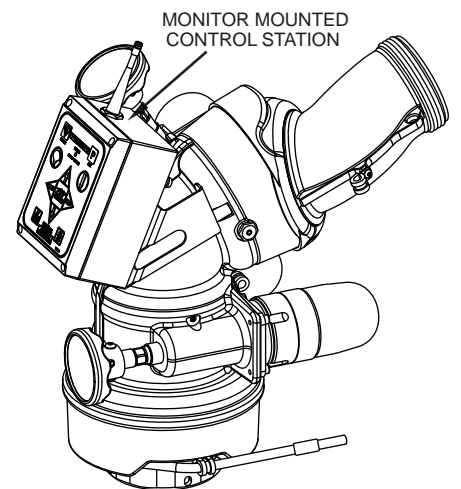



Figure 3.2F
Monsoon RC Standard Model

3.3 INLETS AND OUTLETS

3.3.1 INLETS OPTIONS AND ADDITIONAL HEIGHT

Various other inlet and outlet options are available as shown in figure 3.3.

3.3.1.1 FLANGES

	INLET OPTION #	PART NUMBER	MONITOR INLET ADAPTER	MONITOR INLET BASE	ADDITIONAL HEIGHT*		QUICK CONNECT OPTION # **	PART NUMBER	Manual & Electric		Tiller	
					in	mm			ADDITIONAL HEIGHT*		ADDITIONAL HEIGHT*	
									in	mm	in	mm
	1	Y4410A	3" ANSI 150 FLANGE	TFT CODE-RLF	0.75	20						
	2	Y4415A	4" ANSI 150 FLANGE	TFT CODE-RPF	0.94	23	R	Y4482	3.83	96	6.58	166
	3	Y4417A	6" ANSI 150 FLANGE	TFT CODE-RPF	1.00	25						
	4	Y4423A	DN80, PN16 FLANGE	TFT CODE-RLF	0.87	22						
	5	Y4425A	DN100, PN16 FLANGE	TFT CODE-RPF	0.87	22						

3.3.1.2 NPT FEMALE

	INLET OPTION #	PART NUMBER	MONITOR INLET ADAPTER	MONITOR INLET BASE	ADDITIONAL HEIGHT*		QUICK CONNECT OPTION # **	PART NUMBER	Manual & Electric		Tiller	
					in	mm			ADDITIONAL HEIGHT*		ADDITIONAL HEIGHT*	
									in	mm	in	mm
	6	Y4440NL	3" NPT FEMALE	TFT CODE-RLF	2.00	51						
	7	Y4450NP	4" NPT FEMALE	TFT CODE-RPF	1.75	45	S	Y4483	3.63	92	6.38	162

3.3.1.3 BSP MALE

	INLET OPTION #	PART NUMBER	MONITOR INLET ADAPTER	MONITOR INLET BASE	ADDITIONAL HEIGHT*		QUICK CONNECT OPTION # **	PART NUMBER	Manual & Electric		Tiller	
					in	mm			ADDITIONAL HEIGHT*		ADDITIONAL HEIGHT*	
									in	mm	in	mm
	8	Y4420A	3" BSP MALE THREAD	TFT CODE-RLF	2.30	58						
	9	Y4430A	4" BSP MALE THREAD	TFT CODE-RPF	2.30	58						

* SEE SECTION 3.4 OVERALL DIMENSIONS FOR NOMINAL MONITOR DIMENSIONS

** FOR QUICK CONNECT OPTIONS REFERENCE LIY-250

3.3.1.4 MATING PRODUCTS

INLET OPTION #	PART NUMBER	MONITOR INLET ADAPTER	MONITOR INLET BASE	ADDITIONAL HEIGHT*		QUICK CONNECT OPTION #**	PART NUMBER	ADDITIONAL HEIGHT*		ADDITIONAL HEIGHT*	
				in	mm			in	mm	in	mm
L	see LIX-512	FOR EXTEND-A-GUN 3"	TFT CODE-RLF	0.00	0	T	Y4487	3.83	96	6.58	166
	see LIX-530	FOR EXTEND-A-GUN RC3	TFT CODE-RLF								
P	see LIX-530	FOR EXTEND-A-GUN RC4	TFT CODE-RPF	0.00	0	U	Y4486	3.63	92	6.38	162

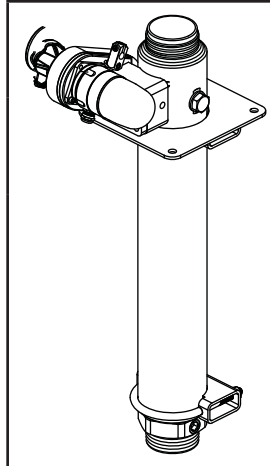

INLET OPTION #	PART NUMBER	MONITOR INLET ADAPTER	MONITOR INLET BASE	ADDITIONAL HEIGHT*		QUICK CONNECT OPTION #**	PART NUMBER	ADDITIONAL HEIGHT*		ADDITIONAL HEIGHT*	
				in	mm			in	mm	in	mm
P	see LIA-285	FOR AK SERIES VUM	TFT CODE-RPF	0.00	0	Q	N/A	0.63	16	3.38	86
	see LIZ-055	FOR ZB SERIES HUM	TFT CODE-RPF								
X	see LIZ-050	MANUAL OR ELEC FOR ZA SERIES 4" IVUM	TFT CODE-RRM	-0.59	-15						
	see LIZ-050	TILLER FOR ZA SERIES 4" IVUM	TFT CODE-RRM	0.71	18						

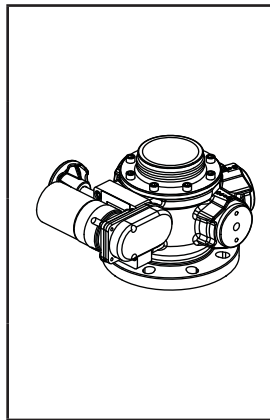

* SEE SECTION 3.4 OVERALL DIMENSIONS FOR NOMINAL MONITOR DIMENSIONS
 ** FOR QUICK CONNECT OPTIONS REFERENCE LIY-250

3.3.2 OUTLET OPTIONS

OUTLET OPTIONS			
OPTION #	THREAD	UPPER SEGMENT	ADAPTER
1	3.5" NH MALE	Y4310A	N/A
2	3.5" BSP MALE		Y4330ABN
3	3.5" NPSH MALE		Y4330AIN
4	4.0" BSP MALE		Y4334ABP
5	2.5" NH MALE	Y4311	N/A
6	2.5" BSP MALE		X332BJ
7	2.5" NPSH MALE		X332IJ

3.4 OVERALL DIMENSIONS

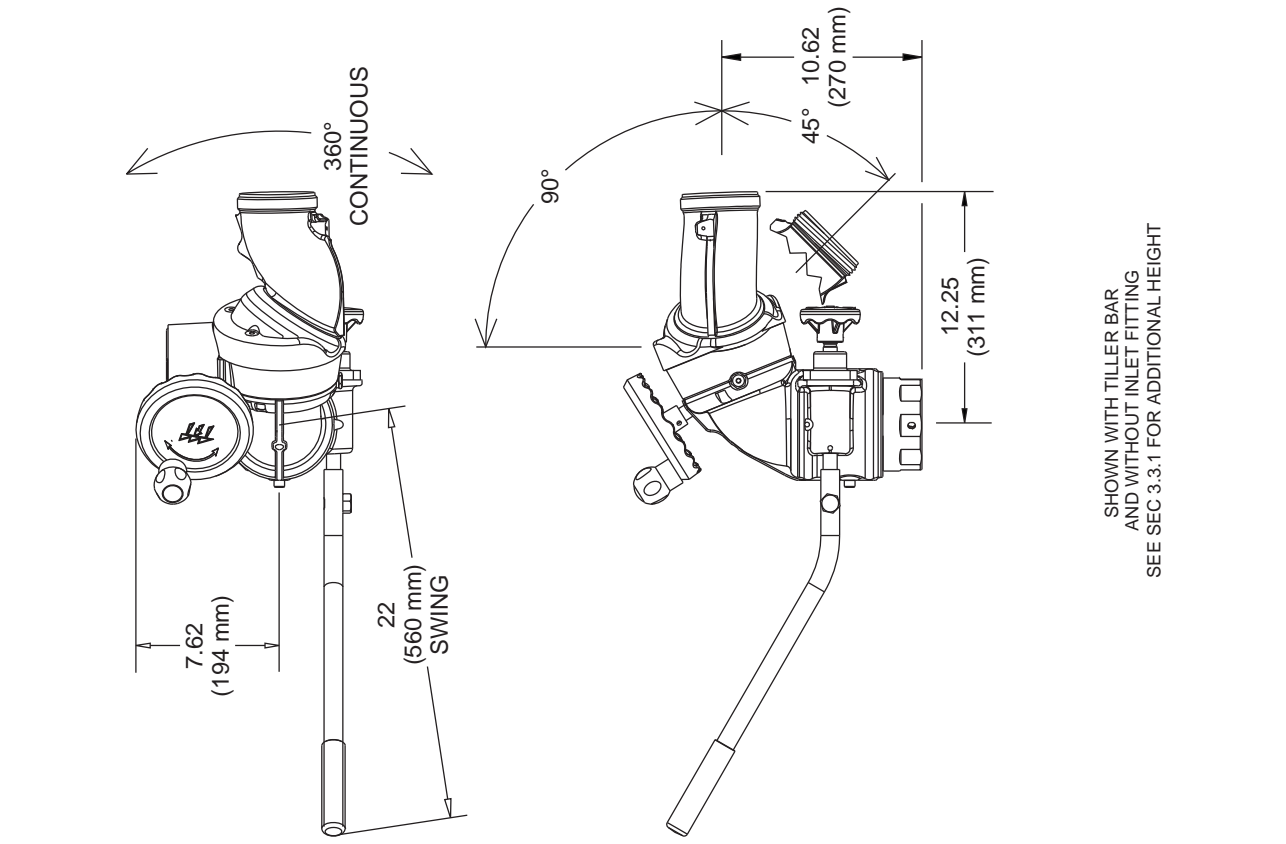

Manual Tiller Bar Monsoon Dimensions
Figure 3.4B

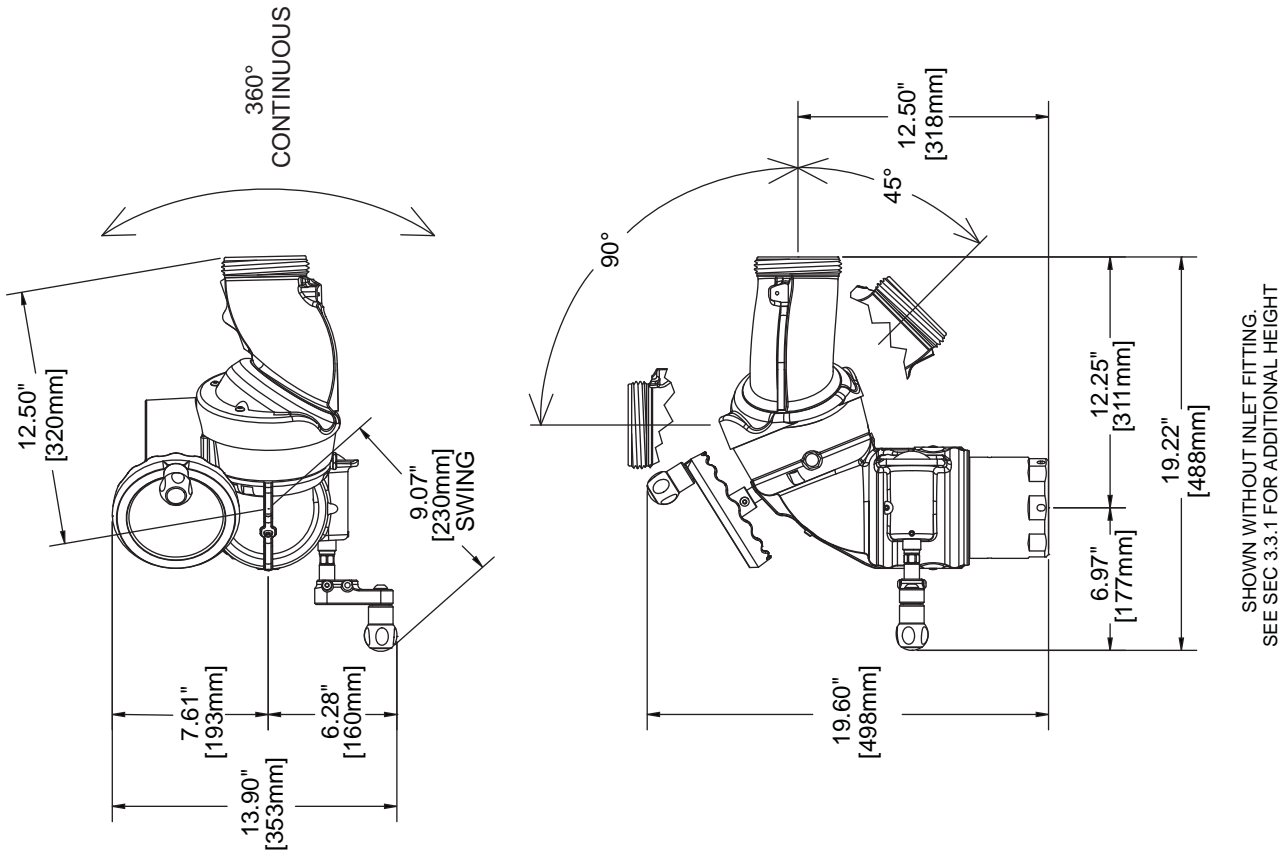

Manual Monsoon Dimensions
Figure 3.4A

3.4 OVERALL DIMENSIONS

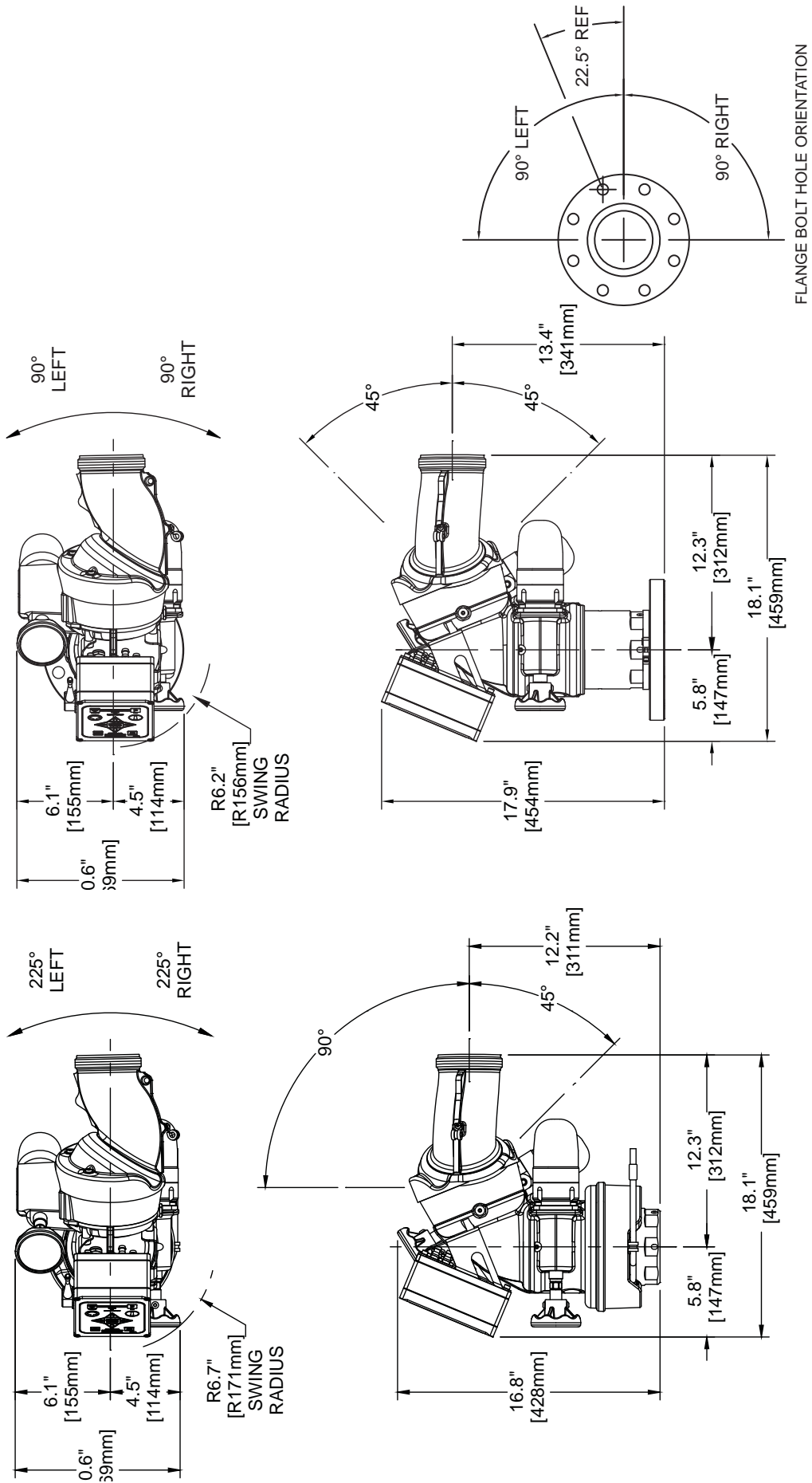

Monsoon RC For Platform Dimensions

Figure 3.4D

Monsoon RC Dimensions

Figure 3.4C

3.4 OVERALL DIMENSIONS

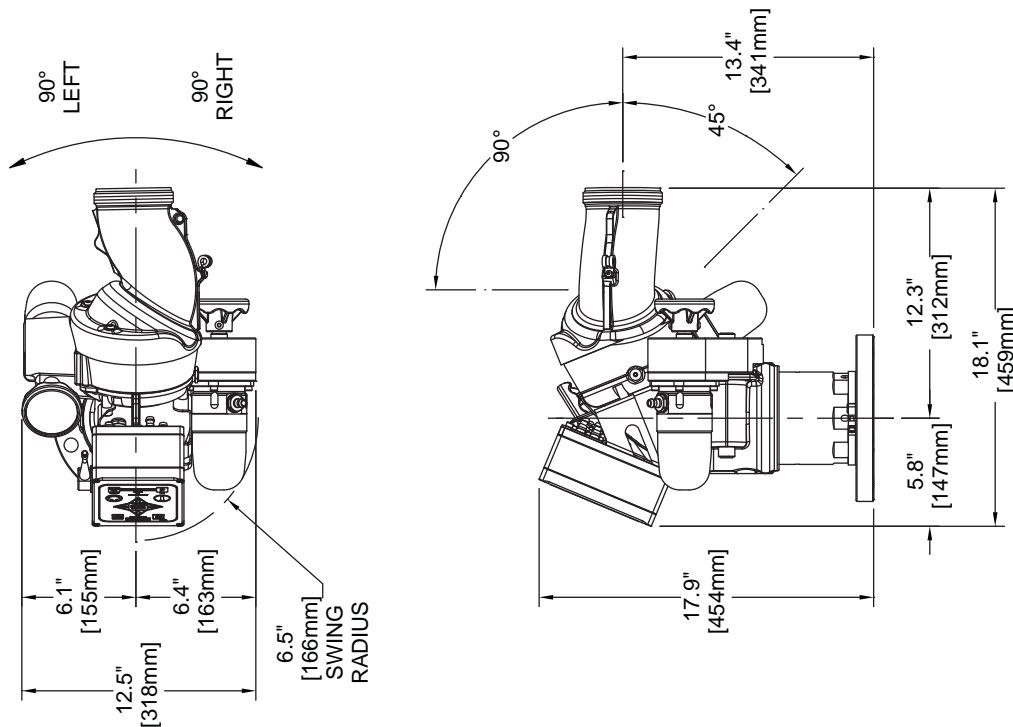

Monsoon RC For Ladder Dimensions

Figure 3.4E

4.0 INSTALLATION

See Remote Control (RC) Monitor Electrical Controls Supplemental Instructions LIY-500.

4.1 STRUCTURAL REQUIREMENTS FOR MONITOR MOUNTING

The structure that the Monsoon Monitor is mounted to must withstand the internal pressure of the monitor as well as shear and bending forces due to nozzle reaction. Nozzle reaction can be as high as 1,500 lbs (700 kg) (2000 gpm at 200 psi).

For flanged connections the use of flat flanges without raised faces is recommended. Use a ring gasket as defined in ASME 16.21 or ISO 7483. Tighten flange bolts in an alternating sequence as shown in figure 4A. Tighten to 76-80 ft-lb (100-110 Newton-Meters).

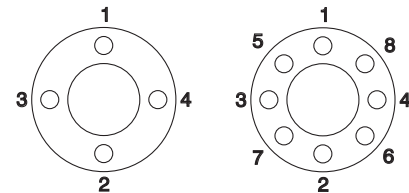

Tighten sequentially each bolt three times.

Fig 4.1 Flange Bolt Tightening Sequence

FLANGE TYPE	OPT#	OUTSIDE DIAMETER		THICKNESS		BOLT HOLE CIRCLE		# OF BOLTS	SIZE OF BOLTS		TORQUE ON BOLTS	
		in	mm	in	mm	in	mm		in	mm	ft-lbs	N-m
3" ANSI 125/150 - DN80 PN20	1	7.5	190	0.75	20	6.0	152.5	4	5/8	16	76-80	100-110
4" ANSI 150 - DN100 PN20	2/R	9.0	230	0.94	23	7.5	190	8	5/8	16	76-80	100-110
6" ANSI 150 FLANGE	3	10.9	277	1.0	25.4	9.5	241.3	8	3/4	19	76-80	100-110
DN80, PN16 FLANGE	4	7.9	200	0.87	22	6.3	160	8	5/8	16	76-80	100-110
DN100, PN16 FLANGE	5	8.7	220	0.87	22	7.1	180	8	5/8	16	76-80	100-111



Injury can result from an inadequately supported monitor. The monitor mount must be capable of supporting the nozzle reaction force which can be as high as 1500 lbs (700 kg). Flanges and pipe made from plastic are inadequate for monitor mounting and must not be used. This monitor is not recommended for portable use.

4.2 INLET MOUNTING AND TRAVEL RANGES

4.2.1 TWO PIECE CLAMP ROTATIONAL LOCK INSTALLATION INSTRUCTIONS

- 1) Assemble Clamps and place loosely on Inlet Adapter or Extend-A-Gun.
 - A) Apply VSA-125 blue Loctite to threads on Cylinder Nut.
 - B) Loosely install Screws, Washers and Cylinder Nuts on Clamp.
 - C) Grooves on heads of Cylinder Nuts indicate alignment of threaded holes.
 - D) Place Clamp assembly over male threads of outlet.
 - E) Heads of Cylinder Nuts must be on top side of Clamps.
- 2) Screw monitor onto Inlet Adapter or Extend-A-Gun RC until threaded joint bottoms out.
 - A) **NOTICE:** Make sure the Clamps are loose enough to allow the monitor Base to bottom out. The monitor will leak if it does not bottom out in this step.
 - B) **DO NOT USE PIPE SEALANT OR LOCTITE ON THE INLET BASE THREADS.** These threads are sealed with an O-ring. The use of thread locking compounds will make removal difficult.
- 3) Unscrew monitor until the "Straight Ahead Reference Mark" is facing the desired direction.
 - A) Monitor may be unscrewed up to one full turn from the bottomed out position.
 - B) **NOTICE:** Monitor will leak if unthreaded more than one full rotation from bottomed-out condition.
- 4) Rotate the Clamps to the desired orientation.
 - A) Ensure that Clamp assembly does not interfere with RC monitor Power/Com Cable.
- 4) Tighten each Screw gradually until both are finger tight with approximately equal spacing between opposite ends of Clamps.
- 5) Carefully tighten each Screw one additional turn using a 5/32 hex wrench by alternating to the opposite Screw in half turn increments.
 - A) **NOTICE:** Over tightening the Screws will damage Screws and Clamps.

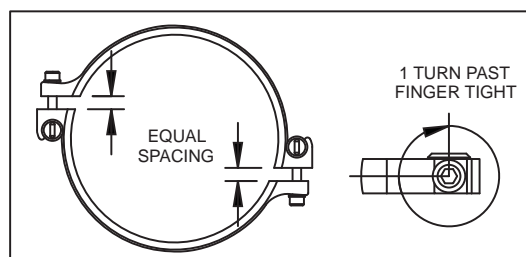
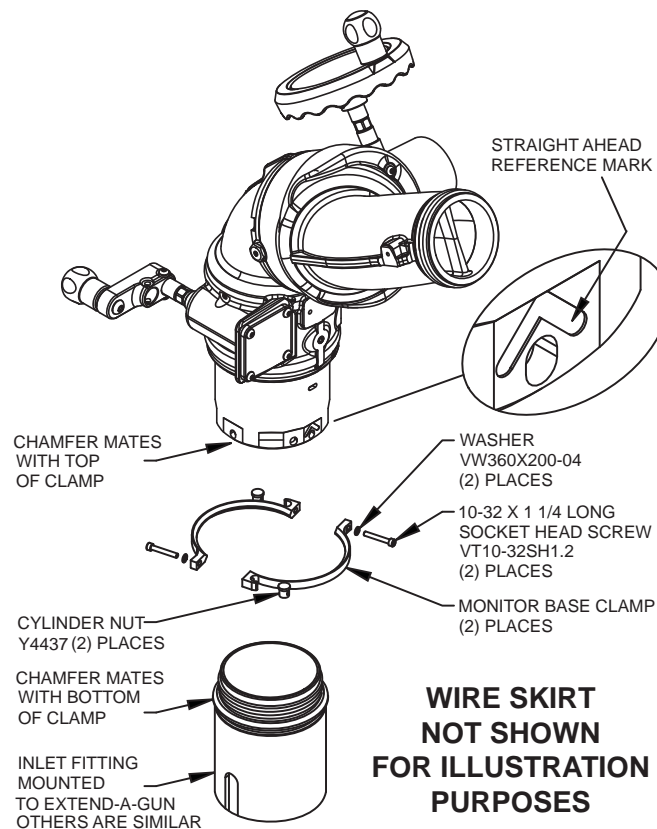

4.2.2 EXTEND-A-GUN RC INSTALLATION

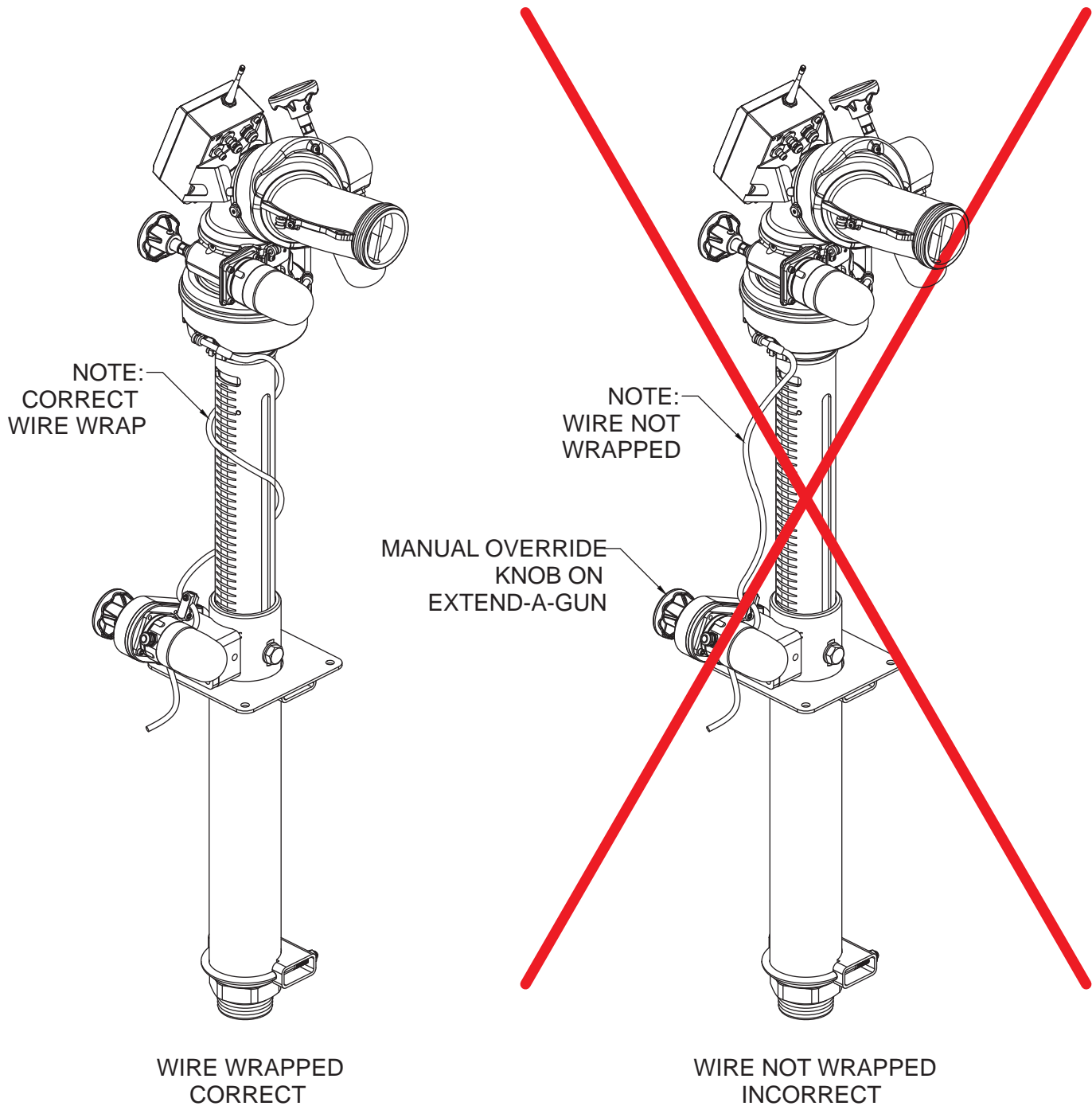

Fig 4.2.1C Possible Extend-A-Gun RC Mounting Orientations

The Extend-A-Gun manual override knob may be mounted in any of four possible orientations (90 degrees apart) relative to the Straight Ahead Reference Mark on the monitor.

NOTE: Monsoon monitor, for use with Extend-A-Gun RC, comes with the wire installed in a nylon tube. The nylon tubing gives the wire additional stiffness so it better follows as the Extend-A-Gun RC extends or retracts.

NOTE: There is a wire clamp provided that is to be used to secure the wire and tubing to the extend-a-gun gearbox.

4.2.3 HORIZONTAL ROTATION TRAVEL STOPS

The range of horizontal rotation travel for the manual Monsoon monitor is continuous 360 degrees. The motorized version is limited to 450 degrees total horizontal rotation travel or 225 degrees from either side of a straight ahead position. Horizontal rotation travel stop bolts may be installed in the monitor to limit travel as shown in figures 4.2.2A and 4.2.2B. Note that left and right are relative to the "Straight Ahead Reference Mark" (the Straight Ahead Reference Mark is shown in figures 4.2.2A and 4.2.2B) and refer to the nozzle's discharge direction as seen from an operator's position behind the nozzle. Figures 4.2.2A and 4.2.2B show the range of travel for the various stop bolt locations and give installation notes.

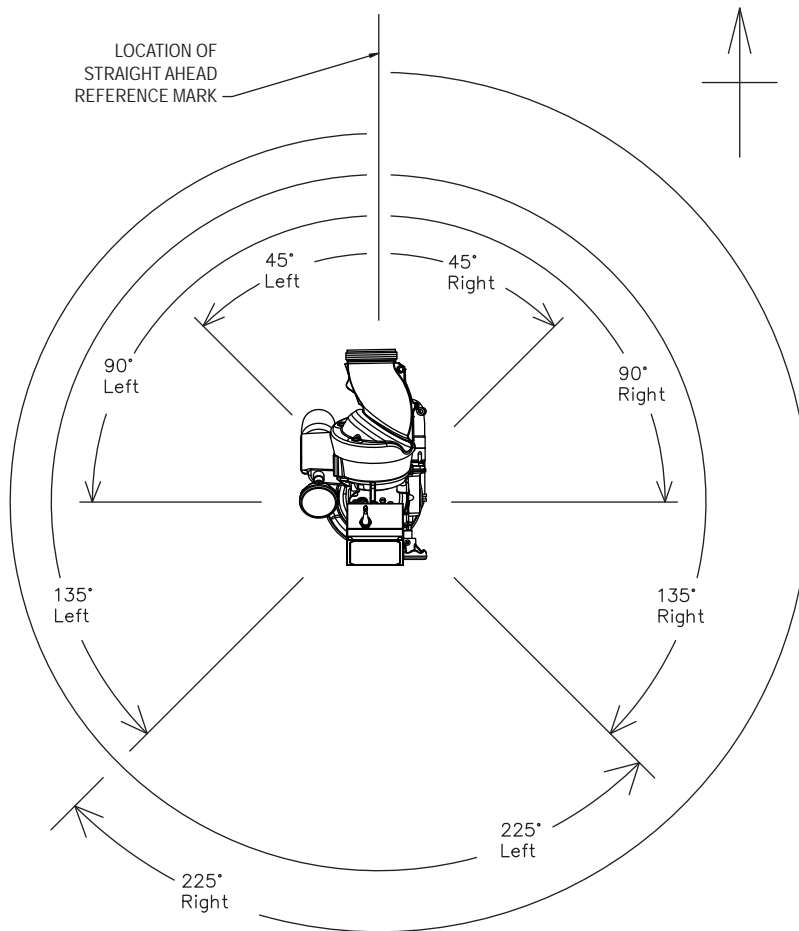

Electric model with no stop bolts installed has 225° left and right horizontal rotation travel limits.

Manual model with no stop bolts installed has continuous 360° horizontal rotation travel.

Fig 4.2.2A
Horizontal Rotation Travel Limits

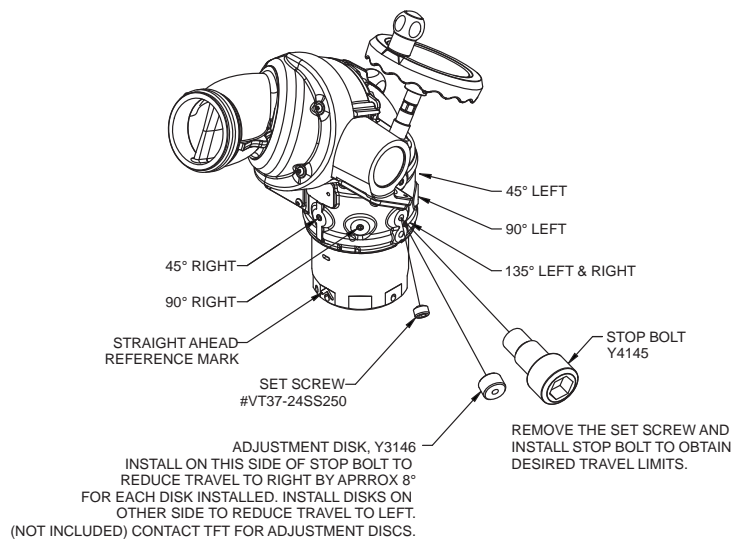

Fig 4.2.2B
Horizontal Rotation Travel Stop Locations

4.2.4 ELEVATION TRAVEL STOPS

The range of elevation travel for the Monsoon Monitor is 90 degrees above horizontal to 45 degrees below zero. The elevation range may be limited by installing the supplied stop bolts at the locations shown in figures 4.2.3A and 4.2.3B. Consult factory for other ranges. The figures include installation notes.

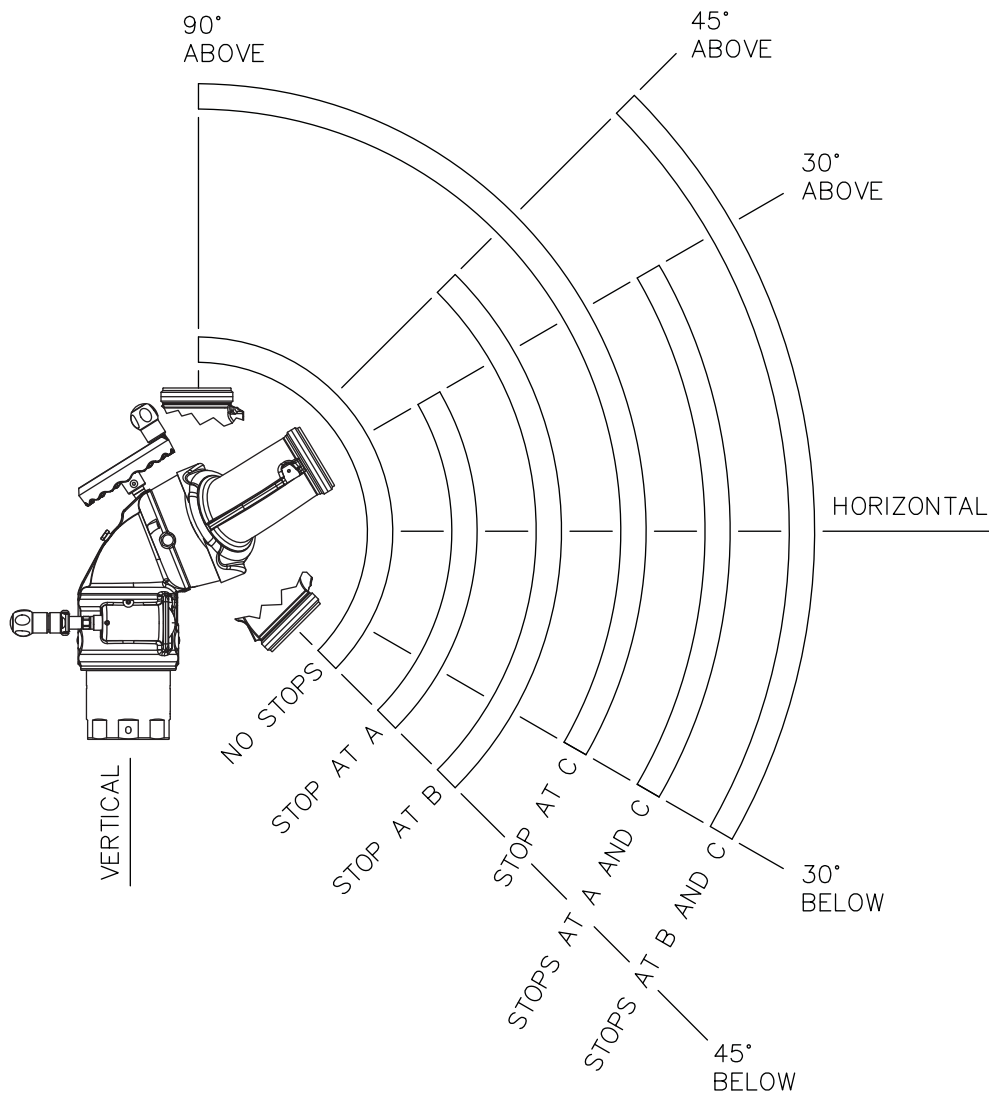

Fig 4.2.3A
Elevation Travel Limits

Remove Set Screw and install Stop Bolt to obtain desired travel limits.
Elevation travel with no Stop Bolts is 90° above and 45° below zero.

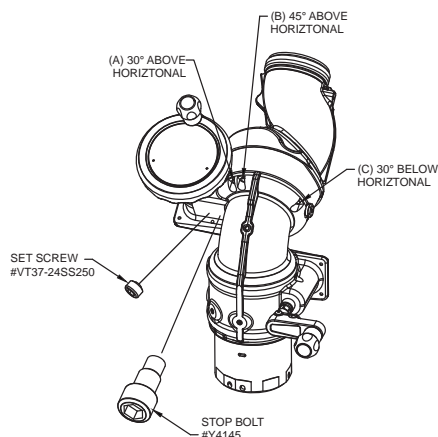

Fig 4.2.3B
Elevation Travel Stop Locations

4.3 NOZZLE INSTALLATION

The nozzle is simply screwed onto the monitor's exit threads. If the nozzle is installed on a Monsoon RC (with electric motors) assure that the nozzle's coupling does not make contact with the horizontal drive motor housing when the monitor is in its lowest elevation position.

For nozzles with electric pattern control, a cable with a female, waterproof connector is provided at the outlet of the Monsoon RC which attaches directly to TFT's electric Masterstream 1250, 1500 or 2000 nozzle. The cable used is a dual-key, micro type plug assembly. Any other nozzle should have the corresponding male electrical connector installed. Do not cut off the female connector on the monitor. This connector is molded onto the cable and must remain in place to maintain the water tightness of the electrical system.

⚠ CAUTION

The nozzle threads must match the threads of the Monsoon monitor in both size and type. Mismatched or damaged threads may cause the nozzle to leak or uncouple under pressure and could cause injury.

⚠ CAUTION

Do not connect aluminum to brass or brass to aluminum. Dissimilar metals coupled together can cause galvanic corrosion that will freeze the threaded joint or cause complete loss of thread engagement. If dissimilar metals must be coupled together, the effects of corrosion can be greatly delayed by various coatings on the metal such as powder paint, hard anodizing, or silicone grease.

4.4 PRESSURE GAGE PORT

There is a 1/4" NPT female threaded hole on the back of the monitor. The hole is plugged from the factory. If a pressure gage is desired, unscrew the plug and install the gage using pipe sealant. Make sure the gage does not interfere with the elevation handwheel.

4.5 HANDLE INSTALLATION INSTRUCTIONS

The tiller handle is shipped loose from the monitor and must be installed to complete the installation process. When installing the tiller handle, be sure to coat the threads of the mounting screw with the Loctite supplied in the hardware packet.

4.6 DRAIN

There is no drain on the Monsoon Monitor itself. A drain valve should be installed on the monitor's inlet piping.

4.7 LADDER MONITOR INSTALLATION

Due to the unique mounting orientations found on ladder trucks, an anti-back-drive mechanism gearbox is included on ladder models to prevent unintended monitor/nozzle movement due to vibration. The gearbox allows the motor and manual override wheel to turn the monitor in both directions, while preventing the monitor from back-driving the motor and manual override wheel. The anti-back-drive gearbox adds to the size of the monitor (see Figure 3.2E), so additional clearance may be needed to prevent interference with the cab in some installations. The anti-back-drive gearbox is removable. Contact factory for instructions.

There is also an electronic method to help prevent unintended monitor/nozzle movement due to vibration. This method is provided for installations where adequate clearance for the anti-back-drive gearbox is not available. The electronic method can only be used if the monitor is always powered while the truck is in operation. See LIY-500 Section 4.13.3 for wiring and programming information.

5.0 OPERATION

5.1 HORIZONTAL ROTATION CONTROL

A handwheel controls the monitor's horizontal rotation direction. Clockwise rotation of the handwheel moves the nozzle to the left and counter-clockwise rotation to the right. Approximately 14 turns of the handwheel will give a 90 degree change in horizontal rotation direction.

5.2 ELEVATION CONTROL

A handwheel controls the monitor's elevation direction. Clockwise rotation of the handwheel raises the elevation and counter-clockwise lowers it. About 50 turns of the handwheel will give the complete 135 degree elevation travel range of the monitor.

5.3 TILLER BAR MODEL

On the Tiller Bar model the horizontal rotation is changed by pushing or pulling horizontally on the Tiller Handle. Twisting the Rotation Locking Knob clockwise will increase the drag on the lower swivel joint to "lock" the monitor in a particular direction. See figure 5.3 for the Tiller Bar model controls.

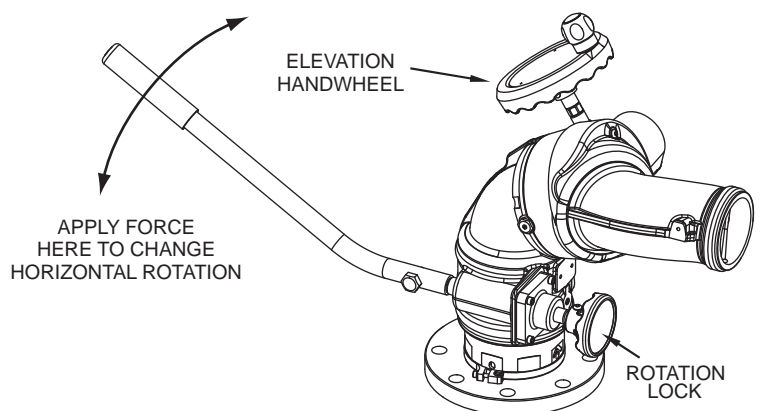

Figure 5.3
Tiller Bar Model Controls

⚠ CAUTION

Injury can result from the monitor changing direction due to an off center nozzle reaction. An off center nozzle reaction may be caused by debris in the nozzle causing an asymmetrical stream. Always keep the rotation lock tight when not rotating the monitor. Always keep one hand on the tiller handle when loosening the locking knob. Where continuous 360 degree rotation of the monitor is not needed it is recommended that the Horizontal Rotation Stop Bolts (see section 4.2.2 for Stop Bolt locations) be installed to reduce any chance of the monitor spinning due to an off center nozzle reaction caused by debris trapped in the nozzle.

5.4 RECOMMENDED PARK POSITION

For truck mounted applications it is recommended that the monitor be parked in a position such that the monitor's nozzle rests against a bracket or support surface. If a support surface is not available, run the elevation against one of its travel stops to take some of the backlash out of the gear drive. This will minimize bouncing of the nozzle when the apparatus is traveling. Always be sure the monitor is properly parked before moving the truck and know the overall height to avoid damage from overhead obstructions such as doors or bridges.

See LIY-500 for information on programming PARK position.

5.5 OVERRIDE KNOBS

In the event of electrical system failure on the monitor or fire truck the Monsoon Monitor is factory supplied with knobs so the monitor may be manually operated. To make the Monsoon RC more compact the manual override knobs may be removed. The drive shafts have a hex so an 11/16" wrench or socket may be used for manual override. Each drive shaft also has a secondary hex at mid shaft so the shaft may be shortened by cutting and still have a wrenching hex. The wrenching hexes are shown in figure 5.5.

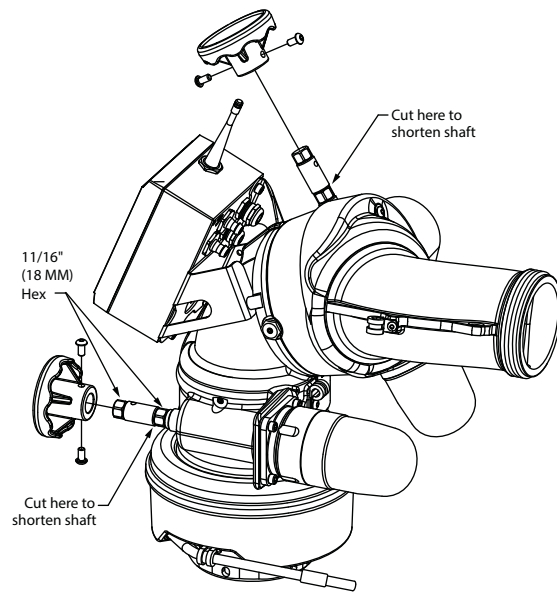

Fig 5.5
Wrenching Hexes on Drive Shaft

6.0 FLOWS AND PRESSURES

6.1 STACKED TIPS FLOW AND REACH

6.1.1 YST-4NM FLOW AND REACH

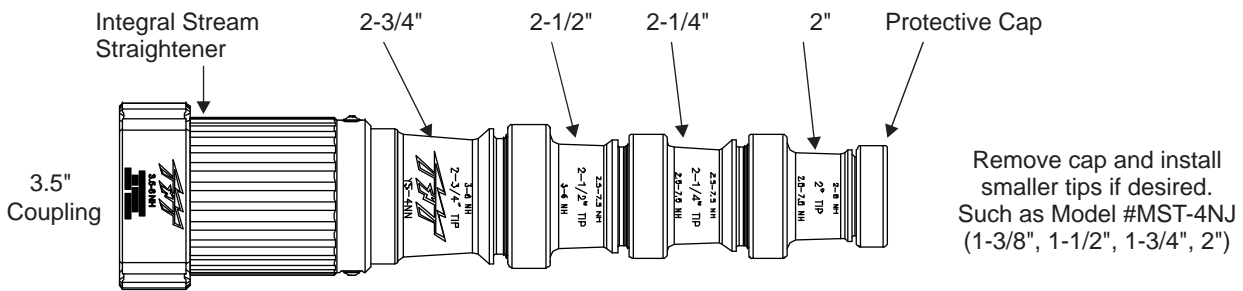

Fig 6.1A
Stacked Tip Model YST-4NN

Nozzle Diameter (inches)	Nozzle Pressure (PSI)							
	50		60		80		100	
	Flow GPM	Reaction lbf	Flow GPM	Reaction lbf	Flow GPM	Reaction lbf	Flow GPM	Reaction lbf
2	840	310	920	380	1060	500	1190	630
2.25	1060	400	1170	480	1350	640	1500	790
2.5	1310	490	1440	590	1660	790	1860	980
2.75	1590	590	1740	710	2010	950	-----	-----

14.5 psi = 1 bar
1 gpm = 3.785 l/min

Nozzle Diameter (MM)	Nozzle Pressure (BAR)							
	3.5		4.1		5.5		7	
	Flow l/min	Reaction kg	Flow l/min	Reaction kg	Flow l/min	Reaction kg	Flow l/min	Reaction kg
50	3180	140	3480	170	4010	230	4500	290
57	4010	180	4430	220	5110	290	5680	360
64	4960	220	5450	270	6280	360	7040	450
70	6020	270	6590	320	7610	430	-----	-----

Fig 6.1B
Stacked Tip Flow Table

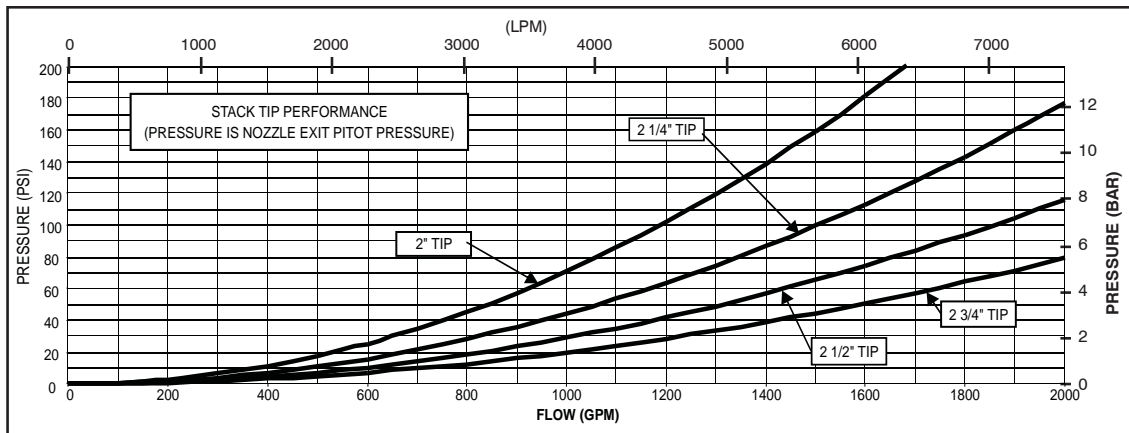

Fig 6.1C Stacked Tip Flow Graph

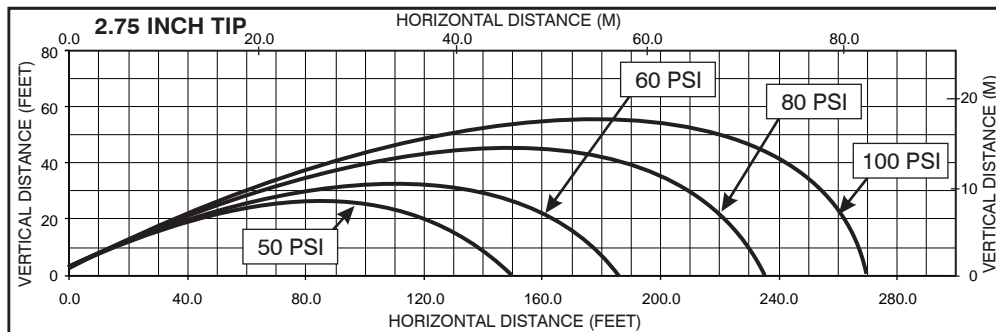
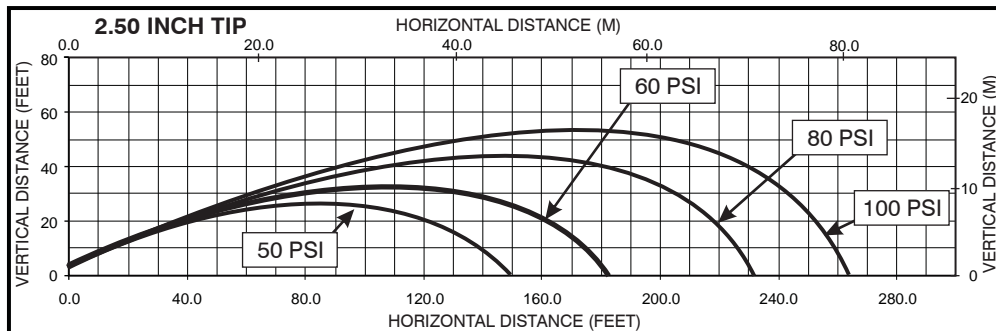
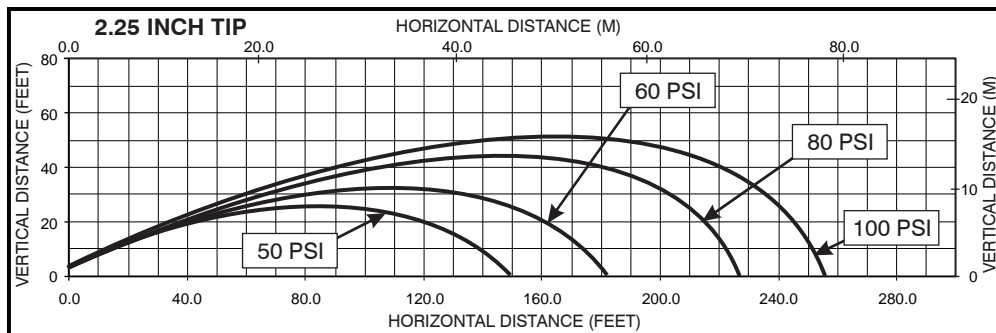
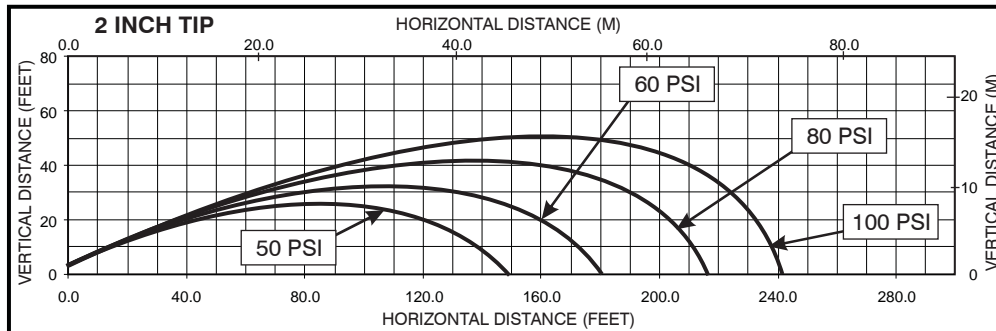

Fig 6.1D
Stacked Tip Stream Trajectory Graphs

This graph is approximate only. Critical applications should be tested in actual conditions to verify adequate reach.

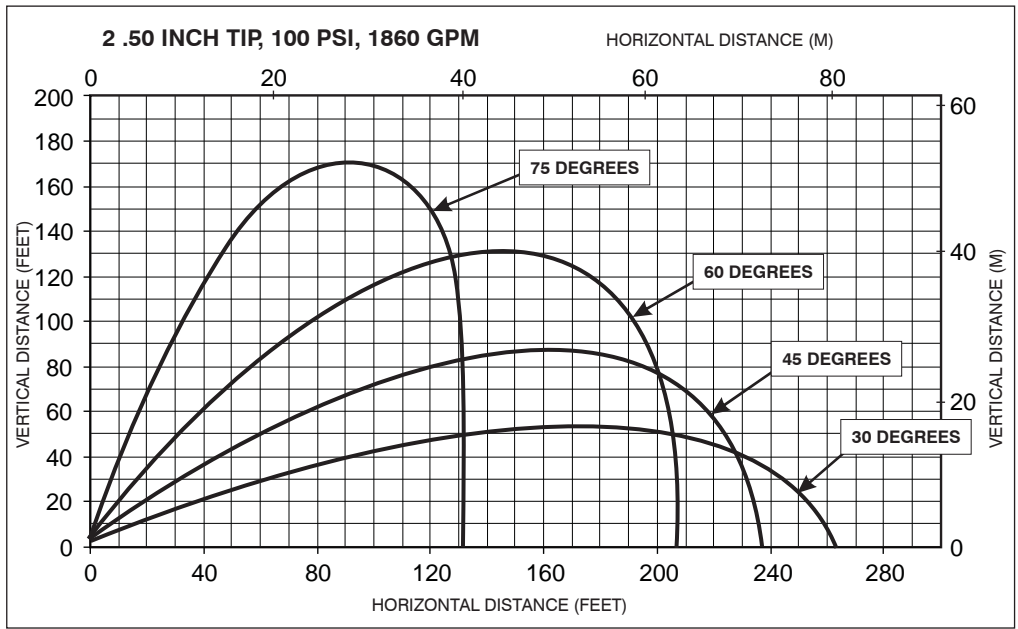

Fig 6.1E
Effects of Elevator Trajectory

This graph shows approximately how a moderate wind can affect stream reach. 1 ft = 0.3048 m

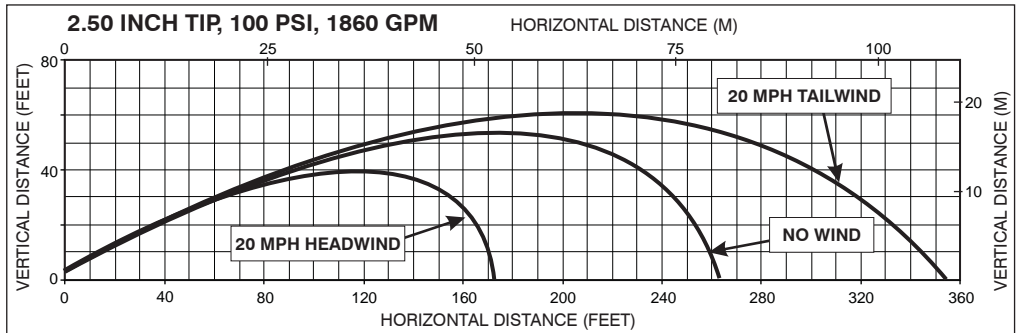
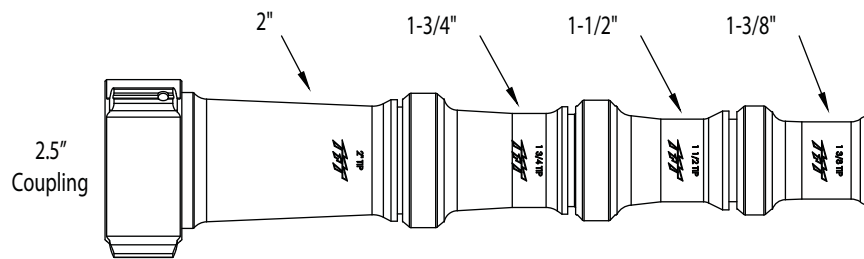

Fig 6.1F
Effects of Wind on Reach

6.1.2 MST-4NJ FLOW AND REACH



NOZZLE DIAMETER (inches)	NOZZLE PRESSURE (PSI)							
	40		60		80		100	
	FLOW (GPM)	REACTION (LBS)	FLOW (GPM)	REACTION (LBS)	FLOW (GPM)	REACTION (LBS)	FLOW (GPM)	REACTION (LBS)
1.375	360	120	440	180	500	240	560	300
1.50	420	140	520	210	600	280	670	350
1.75	580	190	700	290	810	380	910	480
2.00	750	250	920	380	1000	500	1190	630

NOZZLE DIAMETER (MM)	NOZZLE PRESSURE (BAR)							
	2.8		4.1		5.5		7	
	FLOW (l/min)	REACTION (KG)	FLOW (l/min)	REACTION (KG)	FLOW (l/min)	REACTION (KG)	FLOW (l/min)	REACTION (KG)
35	1360	50	1670	80	1890	110	2120	140
38	1590	60	1970	100	2270	130	2540	160
45	2200	90	2650	130	3070	170	3440	220
50	2840	110	3480	170	4010	230	4500	290

Fig. 6.1.2A
Stacked Tips Flow Table

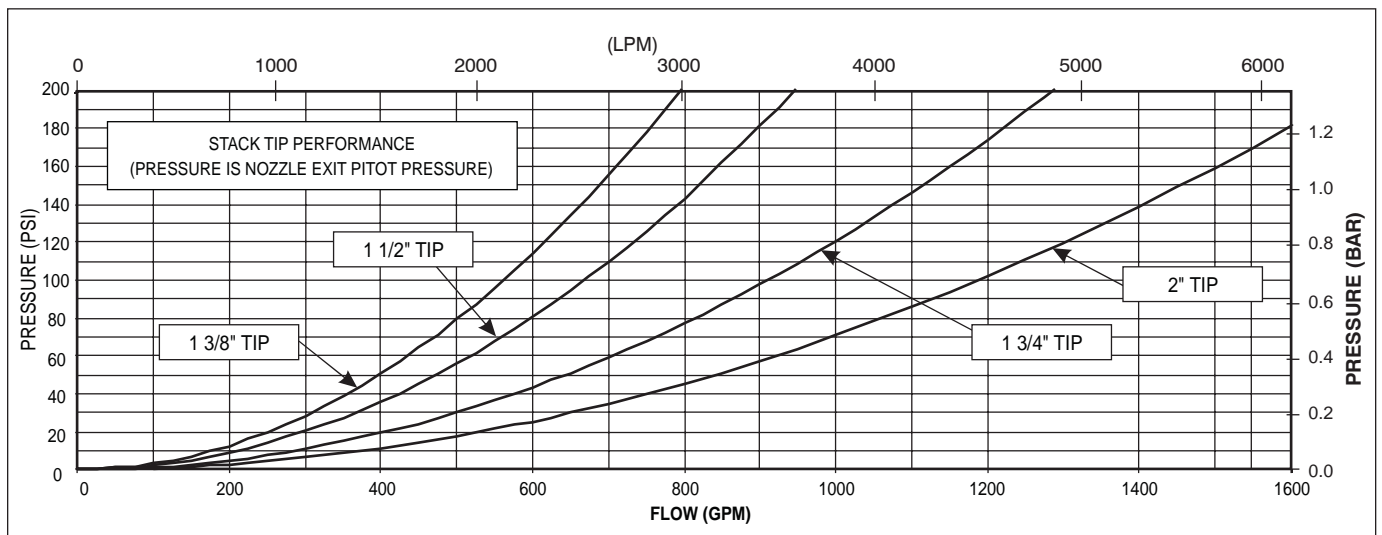

Fig 6.1.2B
Stacked Tips Flow Graph

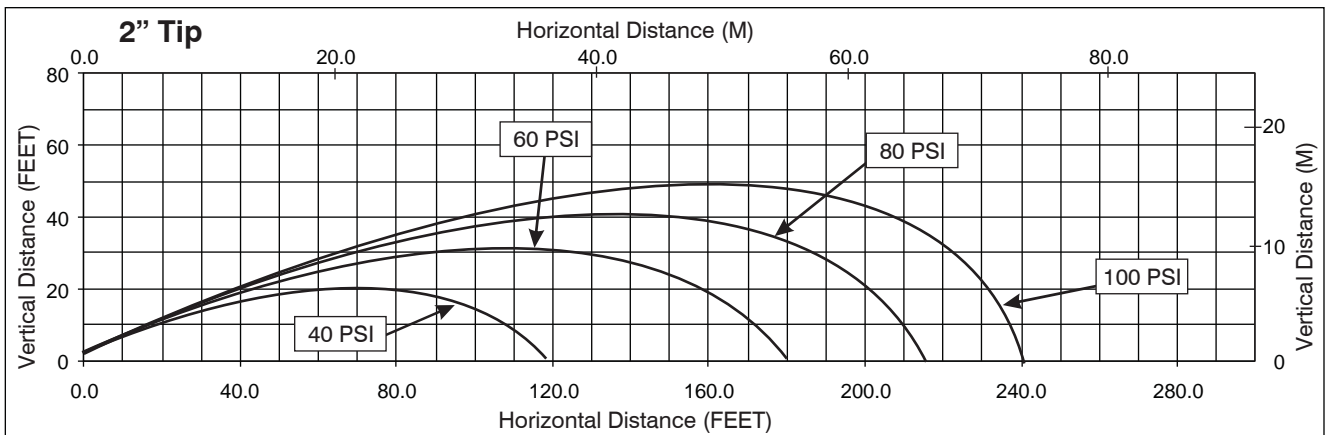
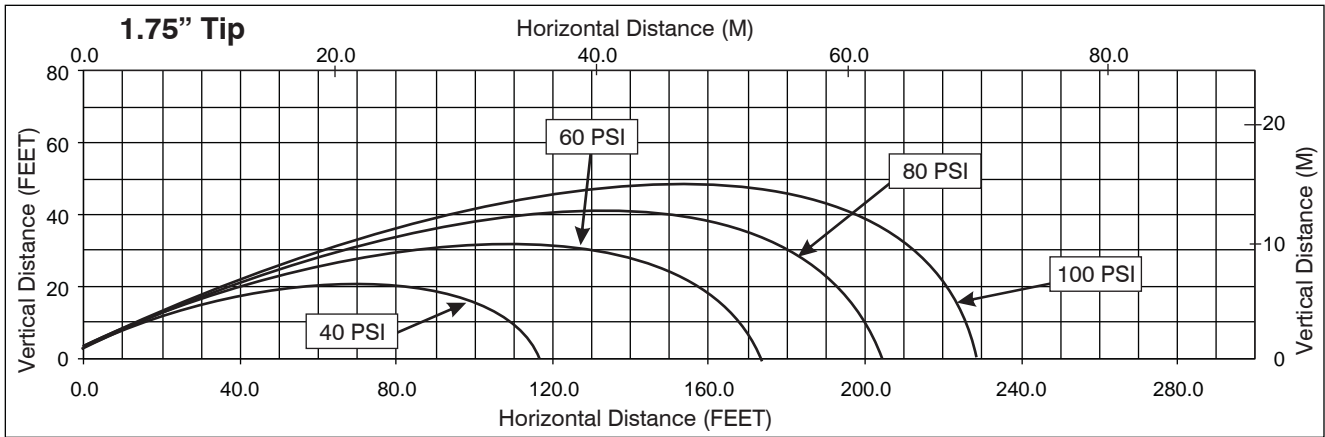
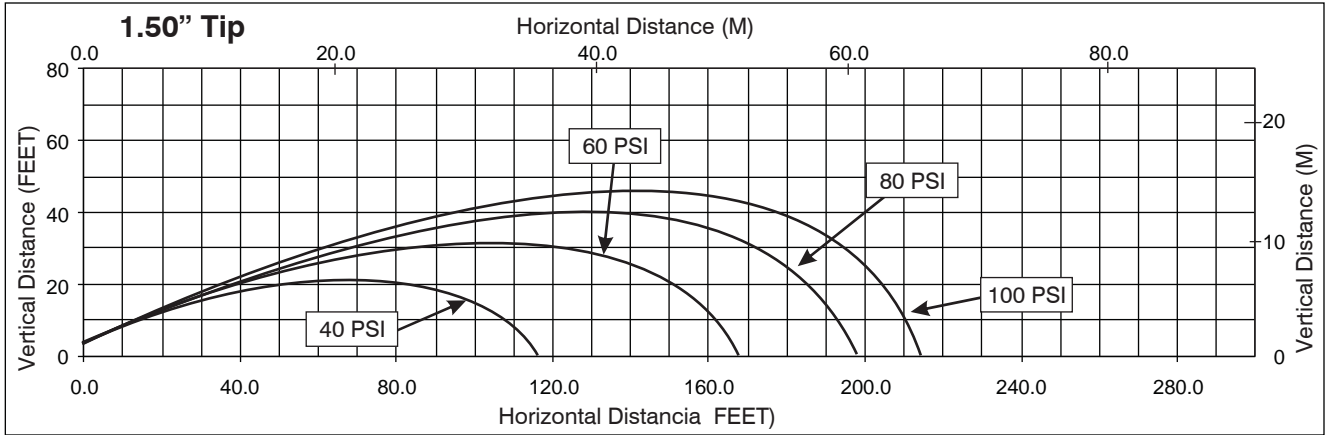
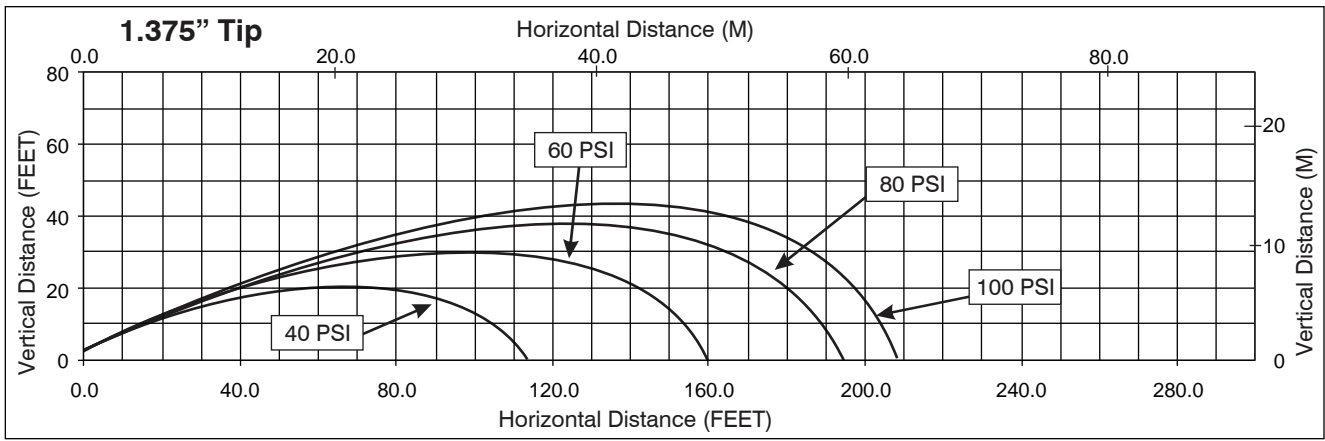
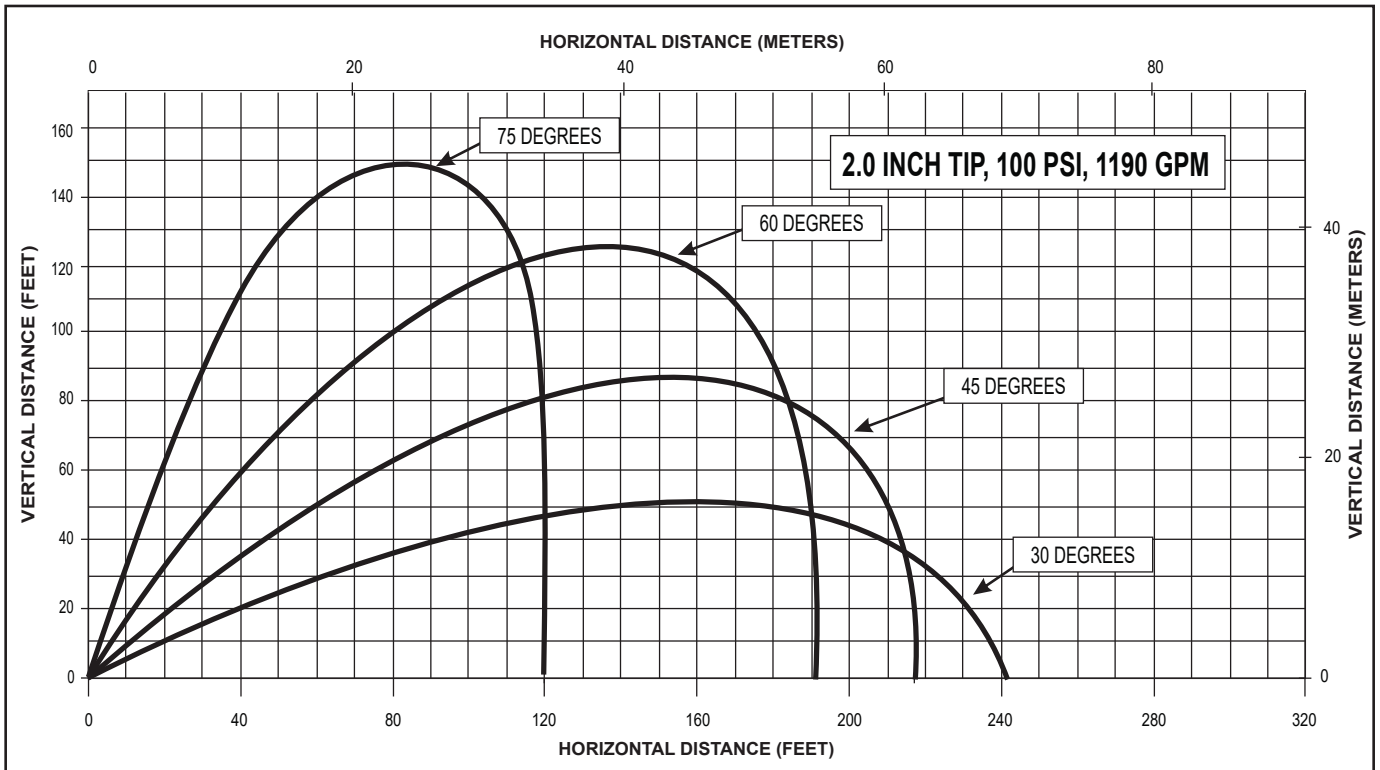
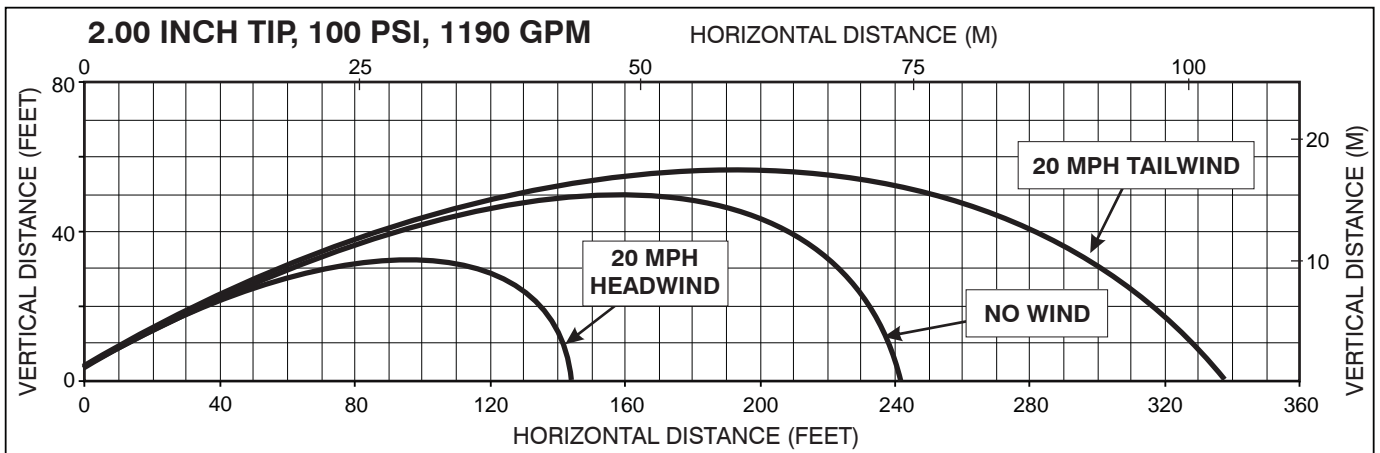

Fig 6.1.2C
Stacked Tips Stream Trajectory Graphs



This graph is approximate only.
 Critical applications should be tested in actual conditions to verify adequate reach.

Fig 6.1.2D
 Effects of Elevation on Trajectory



This graph shows approximately how a moderate wind can affect stream reach. 1 ft = 0.3048 m

Fig 6.1.2E
 Effects of Wind on Reach

6.2 AUTOMATIC MASTERSTREAM NOZZLES

Automatic nozzles maintain a constant pressure by adjusting their orifice to match the available flow. Consult the nozzle manufacturer for maximum flow and pressure range. In all cases do not exceed the safe operating envelope in Fig 3.1.1. See LIM-030 Masterstream nozzle series for information about TFT's Masterstream nozzles.

6.3 MONSOON MONITOR FRICTION LOSS

The discharge size of the monitor determines maximum flow. Excessive turbulence will result if maximum flow is exceeded.

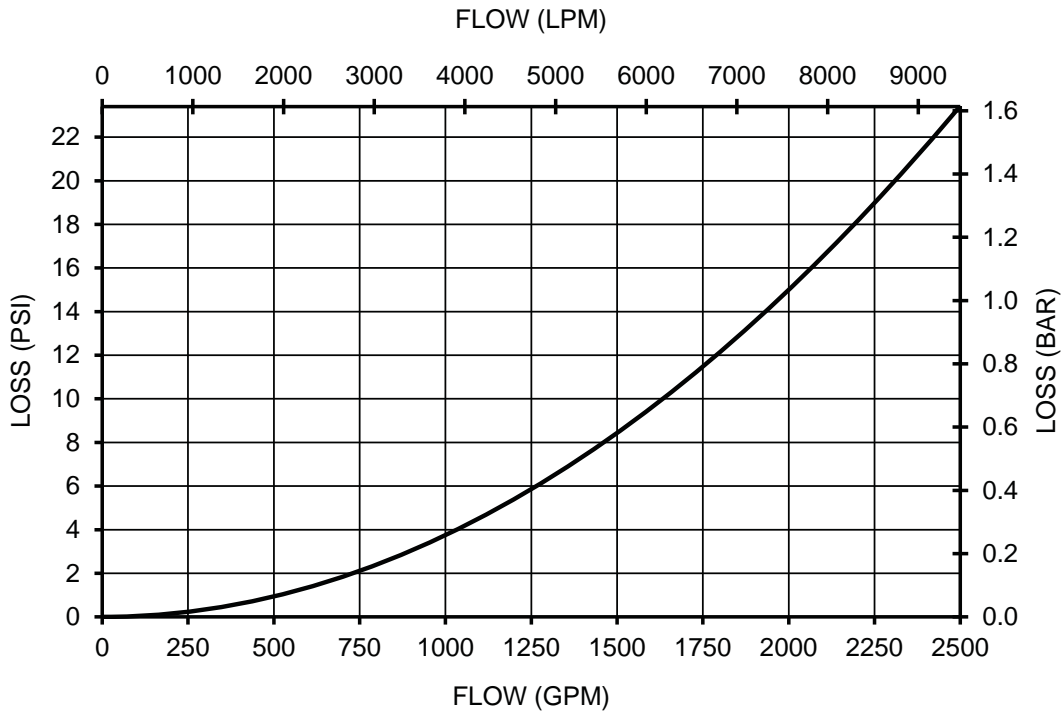

Fig 6.3a
3.5" Monsoon Monitor Friction Loss

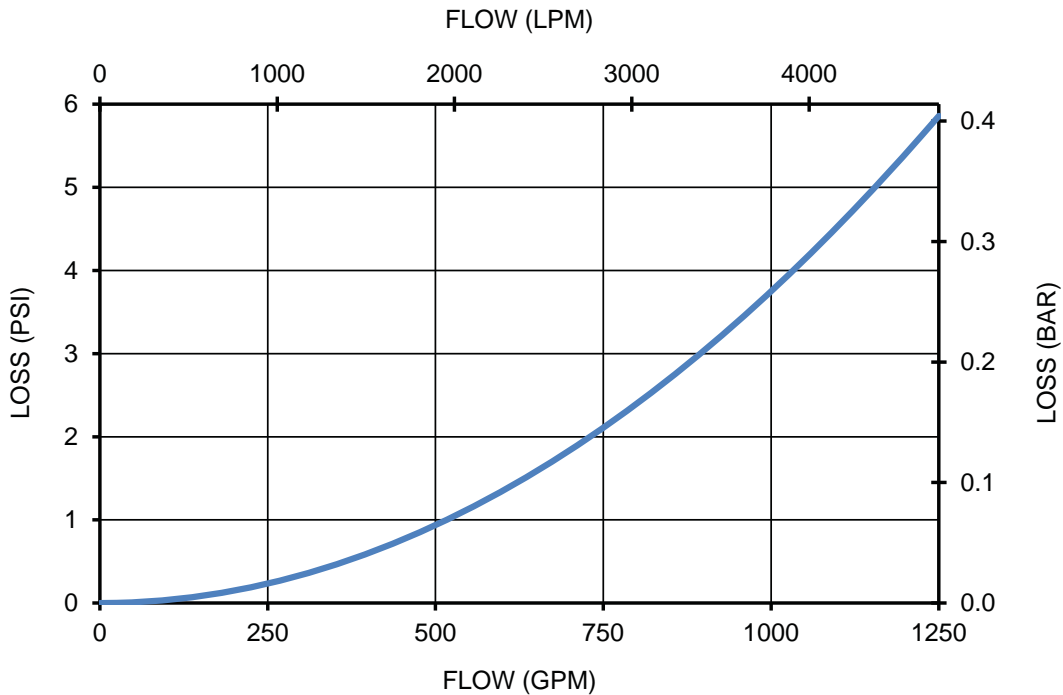

Fig 6.3b
2.5" Monsoon Monitor Friction Loss

6.4 STREAM STRAIGHTENERS

6.4.1 STREAM STRAIGHTENERS WITH STACKED TIPS

Stream quality and reach of smooth bore nozzles can be improved by using stream straighteners. Stream straighteners will add some friction loss as indicated below.

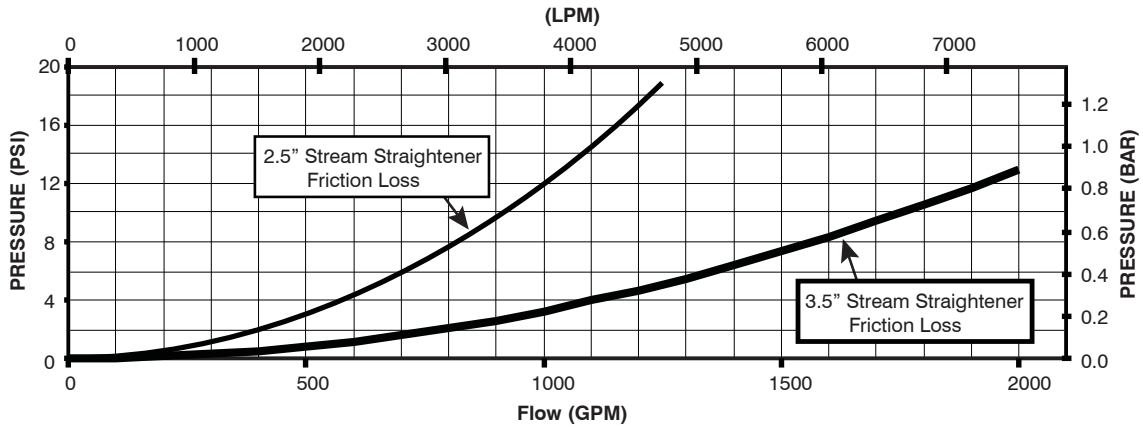
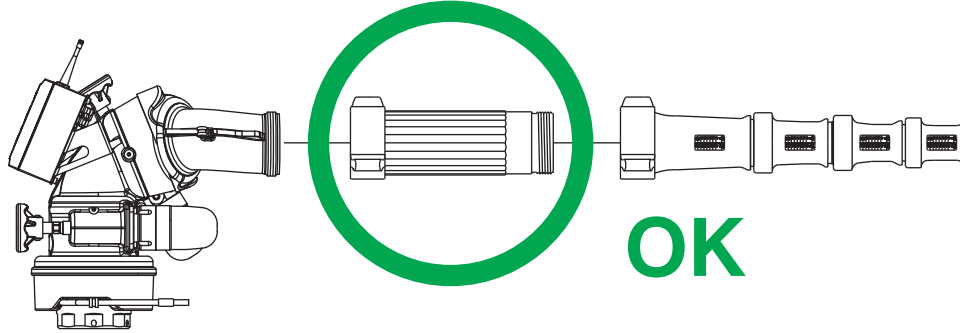
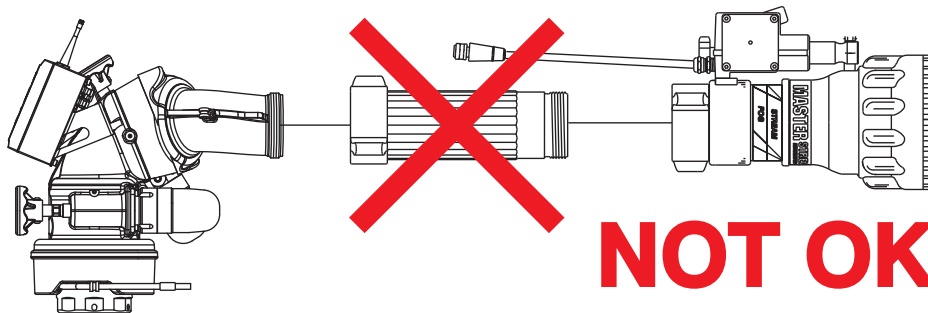

Fig 6.4
TFT Stack Tip Integral Stream Straightener Friction Loss

6.4.2 STREAM STRAIGHTENERS WITH FOG NOZZLES

When using a fog nozzle it is recommended that no stream straightener be used since the fog nozzle's flow path generally serves as a stream straightener. Use of a stream straightener with a fog nozzle will increase the stresses on the monitor's gear train and may lead to premature wear.



7.0 MONSOON DRAWING & PARTS LIST

7.1 MANUAL MONSOON

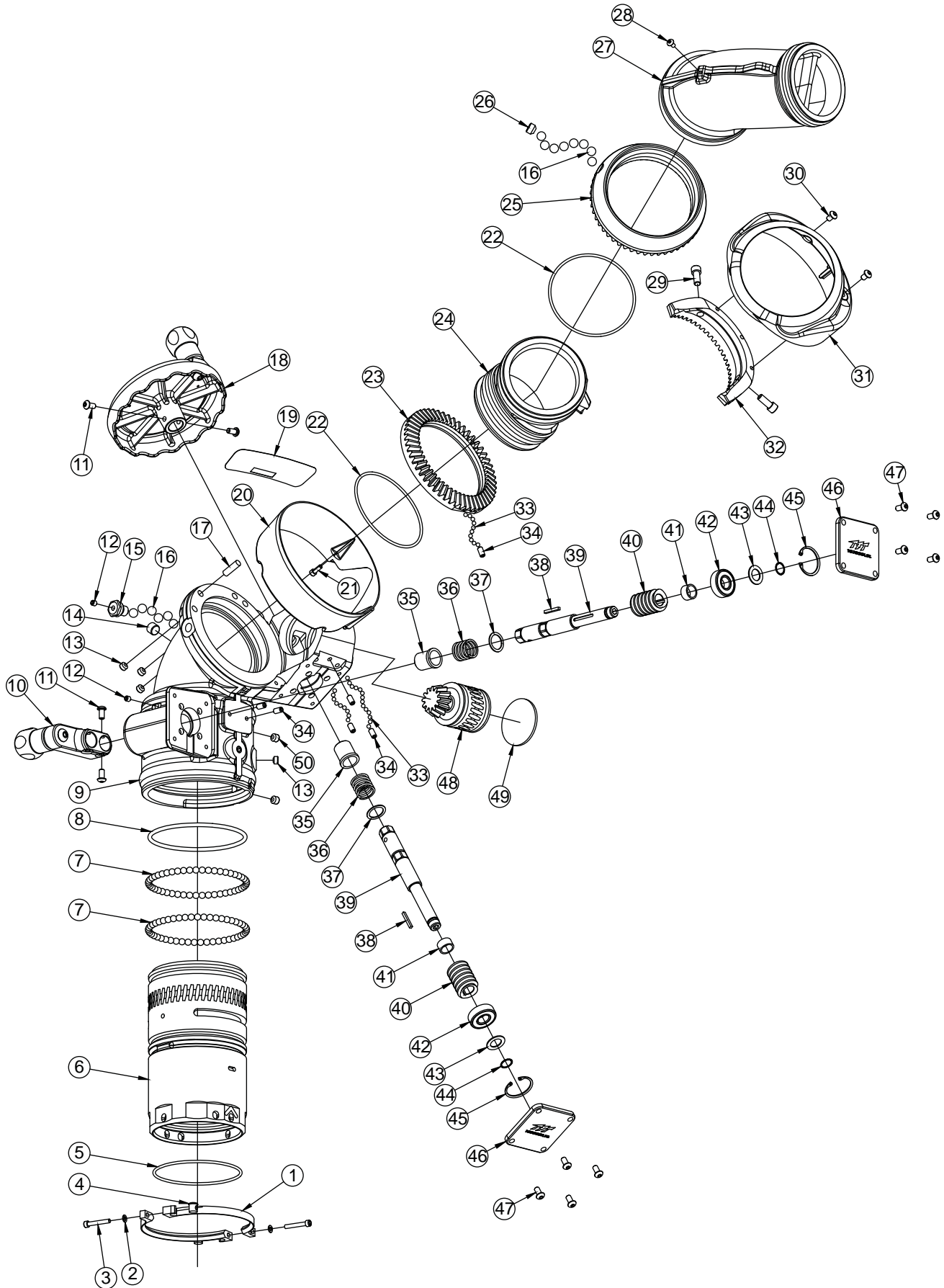

INDEX	DESCRIPTION	QTY	PART #
1	4" MONITOR BASE CLAMP	2	Y4435
	3" MONITOR BASE CLAMP		Y4436
2	WASHER	2	VW360X200-04
3	10-32 X 1 1/4 SOCKET HEAD SCREW	2	VT10-32SH1.2
4	CYLINDER NUT	2	Y4437
5	VO-RING-244	1	VO-244
	VO-RING-236		VO-236
6	BASE CODE-RPF 4"	1	Y4400A
	BASE CODE-RLF 3"		Y4405A
	BASE QUICK CONNECT 4.5"NHF SUBASSY		Y4960
	TILLER BASE QUICK CONNECT 4.5"NHF SUBASSY		Y4961
7	5/16" TORLON BALL (49) PER RACE	98	VB.312TO
8	O-RING-350	1	VO-350
9	LOWER SEGMENT	1	Y4110A
10	CRANK WITH KNOB SUBASSEMBLY	1	A1623
11	1/4-20 X 1/2 BUTTON HEAD SCREW	4	VT25-20BH500
12	1/4-28 X 1/4 SOCKET SET SCREW	2	VT25-28SS250
13	3/8-24 X 3/8 SOCKET SET SCREW	8	VT37-24SS250
14	1/4" NPT PLUG	1	VFSP2M-SS
15	BALL PORT PLUG	1	Y4155
16	7/16" TORLON BALL (32) PER RACE	64	VB437TO
17	DOWEL PIN	1	VP312X1.00
18	ELEVATION HANDWHEEL SUBASSEMBLY	2	Y4941
19	NAME LABEL: MONSOON	1	Y4182
20	LOWER SHROUD	1	Y4130
21	10-24 X 1/2 SOCKET HEAD SCREW	1	VT10-24SH500
22	O-RING-245	2	VO-245
23	LOWER RING GEAR	1	Y4220
24	MIDDLE SEGMENT	1	Y4210A
25	UPPER RING GEAR	1	Y4320
26	1/2-20 X 3/8 SOCKET SET SCREW	1	VT50-20SS375
27	3.5" UPPER SEGMENT	1	Y4310A
	2.5" UPPER SEGMENT		Y4311
28	10-24 X 3/8 BUTTON HEAD SCREW	1	VT10-24BH375
29	5/16-18 X 3/4 SOCKET HEAD SCREW	2	VT31-18SH750
30	1/4-20 X 3/8 BUTTON HEAD SCREW	2	VT25-20BH375
31	UPPER SHROUD	1	Y4240
32	HALF RING GEAR	1	Y4230
33	3/16" TORLON BALL	146	V2120-TORLON
34	1/4-28 X 1/2 SOCKET SET SCREW	6	VT25-28SS500
35	HEADED BUSHING	2	Y4141
36	SHAFT SPRING	2	Y4159
37	WASHER	2	VW938X760-04
38	KEY	2	X225
39	DRIVE SHAFT	2	Y4160
40	12 DP WORM	2	X220
41	SPACER	2	Y4150
42	BEARING	2	VM4252
43	WASHER	2	VW97X595-048
44	SMALLEY RING	2	VR4365
45	SNAP RING	2	VR4220
46	COVER PLATE	2	Y4164
47	1/4-28 X 1/2 BUTTON HEAD SCREW	8	VT25-28BH500
48	PINION	1	Y4120
49	PLUG 2-1/4 MOUNTING HOLE	1	Y4162
50	3/8-24 X 5/16 SOCKET SET SCREW	2	VT37-24SS312

7.2 MONSOON RC

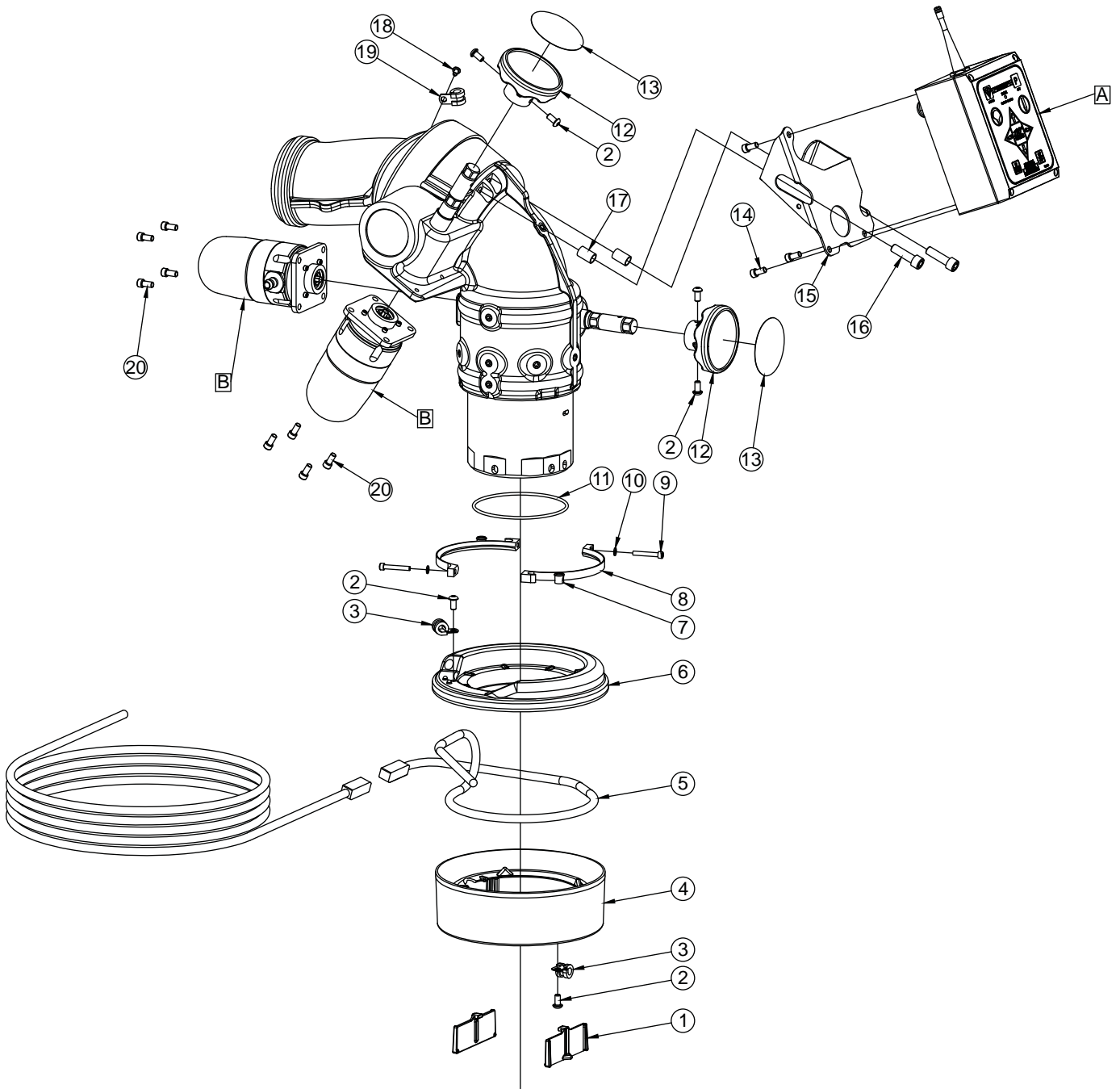

INDEX	DESCRIPTION	QTY	PART #
1	WIRE SKIRT RETAINER	2	Y4661
2	1/4-20 X 1/2 BUTTON HEAD SCREW	6	VT25-20BH500
3	.375 OD LOOP CLAMP STAINLESS	2	Y4655
4	LOWER WIRE SKIRT	1	Y4660
5	CABLE - POWER & COMM.	30'	Y5200
6	UPPER WIRE SKIRT	1	Y4650
7	CYLINDER NUT	2	Y4437
8	4" MONITOR BASE CLAMP	2	Y4435
	3" MONITOR BASE CLAMP		Y4436
9	10-32 X 1 1/4 SOCKET HEAD SCREW	2	VT10-32SH1.2
10	WASHER	2	VW360X200-04
11	VO-RING-244	1	VO-244
	VO-RING-236		VO-236
12	OVERRIDE KNOB	2	Z245
13	OVERRIDE KNOB LABEL	2	Y4176
14	1/4-28 X 1/2 SOCKET HEAD SCREW	3	VT25-28SH500
15	CONTROL BOX BRACKET	1	Y4622
16	3/8-24 X 1-1/4 SOCKET HEAD SCREW	2	VT37-24SH1.2
17	CRANK BUSHING	2	A1513
18	10-24 X 3/8 BUTTON HEAD SCREW	1	VT10-24BH375
19	.500 OD LOOP CLAMP STAINLESS	1	Y4657
20	1/4-28 X 5/8 SOCKET HEAD SCREW	8	VT25-28SH625
A	CONTROL BOX SUBASSEMBLY	1	SEE SECTION 9.4
B	MOTOR ENCLOSURE SUBASSEMBLY	2	SEE SECTION 9.5
* - Length Depends on Configuration.			

7.4 CONTROL BOX SUBASSEMBLY

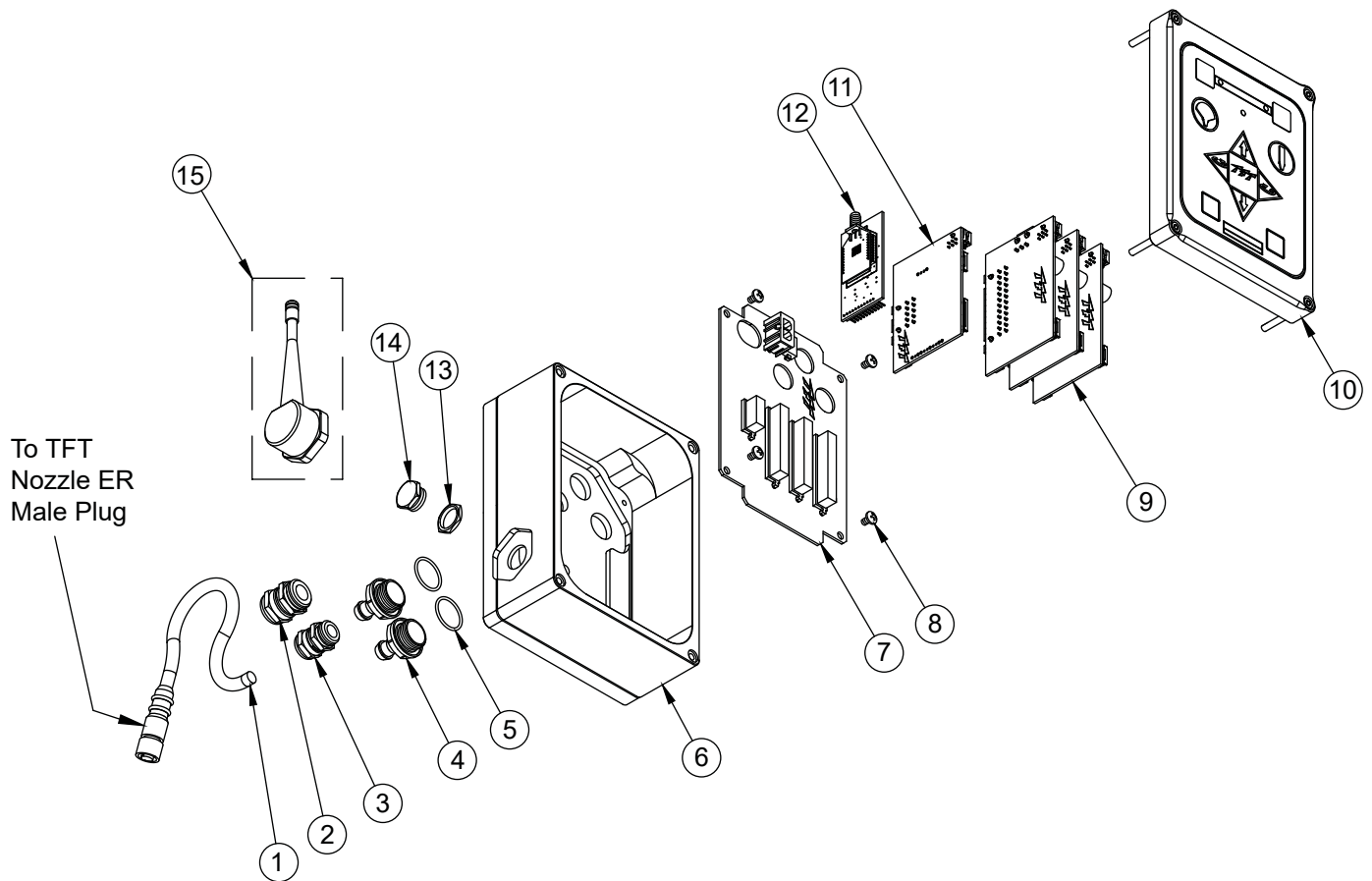

INDEX	DESCRIPTION	QTY	PART #
1	CABLE - 6 POLE FEMALE PLUG	21" or 28" TOTAL LENGTH USED	Y5475
	FOR MONSOON RC NOZZLE CONNECTION	16" or 23" EXPOSED CABLE (NOT INCLUDING PLUG)	
2	PG11 STRAIN RELIEF	1	Y5205A
3	PG9 STRAIN RELIEF	1	Y5245A
4	CONDUIT FITTING	2	Y5213
5	O-RING-018	2	VO-018
6	ENCLOSURE BOX	1	Y5116B
7	MAIN BOARD	1	Y5105
8	M4-0.7 X 6MM PHILLIPS HEAD SCREW	4	VTM4-0.7PH6
9	MOTOR CONTROL BOARD	3	Y5100
10	MONITOR CONTROL BOX SHELL - SUBASSEMBLY	1	Y5801-LID
11	COMMUNICATION BOARD	1	Y5110-B
*12	RADIO + ADAPTER XBEE TO XSTREAM 900 MHZ RADIO	1	Y5891
	RADIO + ADAPTER XBEE TO XSTREAM 2.4 GHZ RADIO		Y5893
13	PG9 LOCKNUT	1	Y5246
14	PG9 HEX PLUG	1	Y5248
*15	900/920 MHZ ANTENNA W/FITTING & CONN. SUBASSY.	1	Y5897
	2.4 GHZ ANTENNA ADAPTER W/CONN. SUBASSY.		Y5898
* - OPTIONAL			

7.5 MOTOR ENCLOSURE SUBASSEMBLY

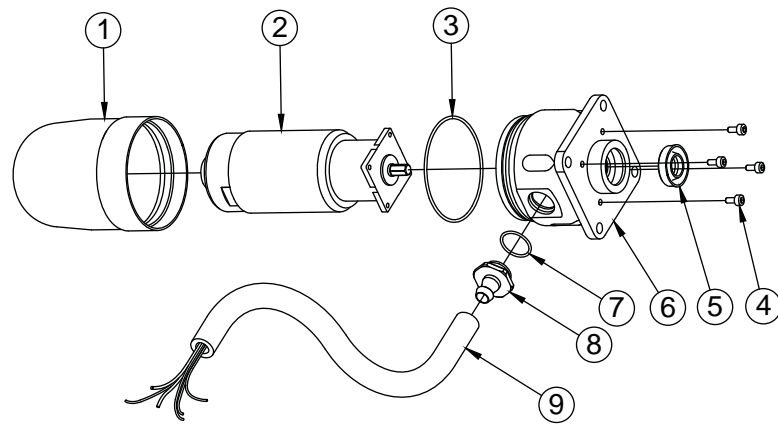

INDEX	DESCRIPTION	QTY	PART #
1	ENCLOSURE	1	Y4616
2	GEAR MOTOR W/CRIMPED TERMINALS	1	Y4611
3	O-RING-038	1	VO-038
4	6-32 X 5/16 LONG SHCS WITH HEAD SEAL	4	VT06S32SH312
5	CUP SEAL	1	Y4620
6	MOTOR SOCKET	1	Y4615
7	O-RING-018	1	VO-018
8	CONDUIT FITTING	1	Y5213
9	HOSE - 3/8" ID PUSH-LOK	1	Y5250

8.0 WARRANTY

Task Force Tips LLC, 3701 Innovation Way, Valparaiso, Indiana 46383-9327 USA ("TFT") warrants to the original purchaser of its Monsoon and Monsoon RC Monitor ("equipment"), and to anyone to whom it is transferred, that the equipment shall be free from defects in material and workmanship during the five (5) year period from the date of purchase.

TFT's obligation under this warranty is specifically limited to replacing or repairing the equipment (or its parts) which are shown by TFT's examination to be in a defective condition attributable to TFT. To qualify for this limited warranty, the claimant must return the equipment to TFT, at 3701 Innovation Way, Valparaiso, Indiana 46383-9327 USA, within a reasonable time after discovery of the defect. TFT will examine the equipment. If TFT determines that there is a defect attributable to it, it will correct the problem within a reasonable time. If the equipment is covered by this limited warranty, TFT will assume the expenses of repair.

If any defect attributable to TFT under this limited warranty cannot be reasonably cured by repair or replacement, TFT may elect to refund the purchase price of the equipment, less reasonable depreciation, in complete discharge of its obligations under this limited warranty. If TFT makes this election, claimant shall return the equipment to TFT free and clear of any liens and encumbrances.

This is a limited warranty. The original purchaser of the equipment, any person to whom it is transferred, and any person who is an intended or unintended beneficiary of the equipment, shall not be entitled to recover from TFT any consequential or incidental damages for injury to person and/or property resulting from any defective equipment manufactured or assembled by TFT. It is agreed and understood that the price stated for the equipment is in part consideration for limiting TFT's liability. Some states do not allow the exclusion or limitation of incidental or consequential damages, so the above may not apply to you.

TFT shall have no obligation under this limited warranty if the equipment is, or has been, misused or neglected (including failure to provide reasonable maintenance) or if there have been accidents to the equipment or if it has been repaired or altered by someone else.

THIS IS A LIMITED EXPRESS WARRANTY ONLY. TFT EXPRESSLY DISCLAIMS WITH RESPECT TO THE EQUIPMENT ALL IMPLIED WARRANTIES OF MERCHANTABILITY AND ALL IMPLIED WARRANTIES OF FITNESS FOR A PARTICULAR PURPOSE. THERE IS NO WARRANTY OF ANY NATURE MADE BY TFT BEYOND THAT STATED IN THE DOCUMENT.

This limited warranty gives you specific legal rights, and you may also have other rights which vary from state to state.

9.0 MAINTENANCE AND INSPECTION

The Monsoon Monitor requires little maintenance. The monitor should be kept clean and free of dirt. All controls should be checked for freedom of movement and proper operation before each use. Any inoperable or damaged parts should be repaired or replaced immediately.

- Make sure that the monitor's axis' rotate freely and without binding throughout its range of travel.
- Make sure that there are no leaks when the monitor is flowing water.
- Make sure the nozzle is free of debris.

Equipment can be returned to the factory for service and/or testing.

Use with saltwater is permissible provided monitor is thoroughly cleaned with fresh water after each use. The service life of the monitor may be shortened due to the effects of corrosion and is not covered under warranty

9.1 LUBRICATION

The Monsoon monitor generally should not require greasing. In the event that the operation becomes stiff grease may be applied to the horizontal rotation and elevation worm gears. The grease is applied by removing the plugs at the grease ports and replacing with grease fittings that have 1/4-28 male threads. See figures 9.1A and 9.1B for grease port locations. Use medium viscosity automotive chassis grease. Apply only enough grease to restore normal operation. If normal operation is not restored by greasing than inspect for other causes of stiff operation.

Note: Do not over pump grease. The monitor's greased areas lead to large chambers that could trap several pounds of grease before becoming visible.

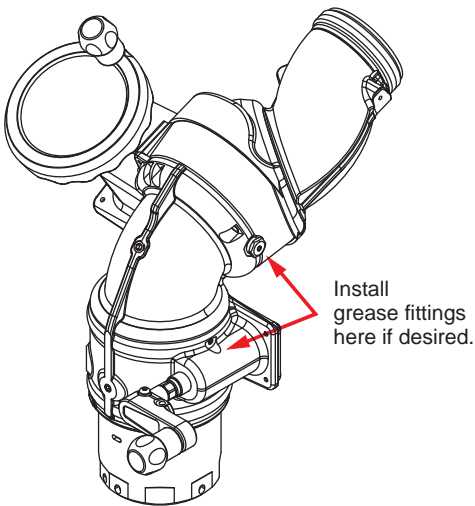

Fig 9.1A
Location of Grease Port for Horizontal Rotation
Worm Gear and Elevator Joint

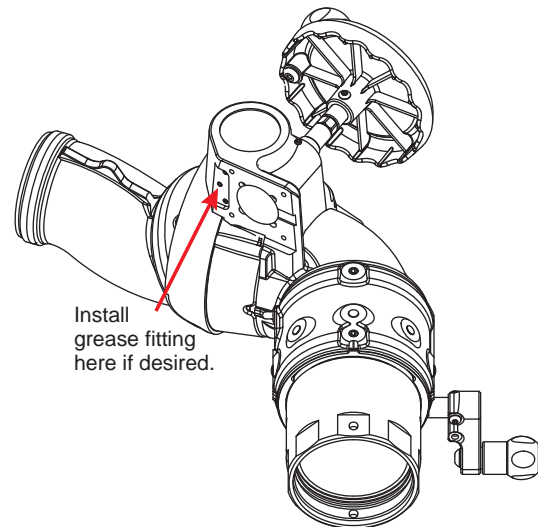

Fig 9.1.B
Location for Grease Port
for Elevation Worm Gear

10.0 TROUBLESHOOTING

SYMPTOM	POSSIBLE CAUSE	REMEDY
Leaks	Debris or damage in seal area	Clean out debris or replace damaged parts
Elevation Binding	Debris or damage to elevation drive parts	Clean out debris or replace damaged parts
	Lack of lubricant	Grease, see section 9.1
Horizontal Rotation Binding	Debris or damage to horizontal drive parts	Clean out debris or replace damaged parts
	Lack of lubricant	Grease, see section 9.1

11.0 REPAIR

Factory service is available with repair time seldom exceeding one day in our facility. Factory serviced appliances are repaired by experienced technicians to original specifications, fully tested and promptly returned.

Repair parts and service procedures are available for those wishing to perform their own repairs. Task Force Tips assumes no liability for damage to equipment or injury to personnel that is a result of user service.

For additional information on care, maintenance and testing, refer to: NFPA 1962: Standard for the Care, Use, Inspection, Service Testing, and Replacement of Fire Hose, Couplings, Nozzles, and Fire Hose Appliances, 2013 Edition

12.0 ANSWERS TO YOUR QUESTIONS

We appreciate the opportunity of serving you and making your job easier. If you have any problems or questions, our toll-free "Hydraulics Hotline", 800-348-2686, is normally available to you 24 hours a day, 7 days a week.

13.0 INSPECTION CHECKLIST

BEFORE EACH USE, appliances must be inspected to this checklist:

- All valves (if so equipped) open and close fully and smoothly
- Waterway is clear of obstructions
- There is no damage to any thread or other connection
- All locks and hold-down devices work properly
- The pressure setting on the relief valve (if so equipped) is set correctly
- Gaskets are in good repair
- There is no obvious damage such as missing, broken or loose parts
- There is no damage to the appliance that could impair safe operation (e.g. dents, cracks, corrosion, or other defects)
- All swiveling elements rotate freely
- Nozzle is securely attached

BEFORE BEING PLACED BACK IN SERVICE, appliances must be inspected to this list:

1. All valves open and close smoothly and fully
2. The waterway is clear of obstructions
3. There is no damage to any thread or other type connection
4. The pressure setting of the relief valve, if any, is set correctly
5. All locks and hold-down devices work properly
6. Internal gaskets are in accordance with NFPA 1962 (2013) Section 7.2
7. There is no damage to the appliance that could impair safe operation (e.g. dents, cracks, corrosion, or other defects)
8. All swiveling connections rotate freely
9. There are no missing parts or components
10. The marking for maximum operating pressure is visible
11. There are no missing, broken, or worn lugs on couplings

NFPA 1962: Standard for the care, use, inspection, service testing, and replacement of fire hose, couplings, nozzles and fire hose appliances. (2013 ed., Section 6.2.1). Quincy, MA: National Fire Protection Agency.



Any monitor failing any part of the inspection checklist is unsafe and must have the problem corrected before use. Operating a monitor that fails any of the above inspections is a misuse of this equipment.