



MANUAL: MONSOON & MONSOON RC MONITOR

See Remote Control (RC) Monitor Electrical Controls Supplemental Instructions For Use With Monsoon RC Models

INSTRUCTIONS FOR INSTALLATION, SAFE OPERATION AND MAINTENANCE

⚠ DANGER

Read instruction manual before use. Operation of this device without understanding the manual and receiving proper training is a misuse of this equipment. A person who has not read and understood all operating and safety instructions is not qualified to operate the Monsoon or Monsoon RC Monitor.

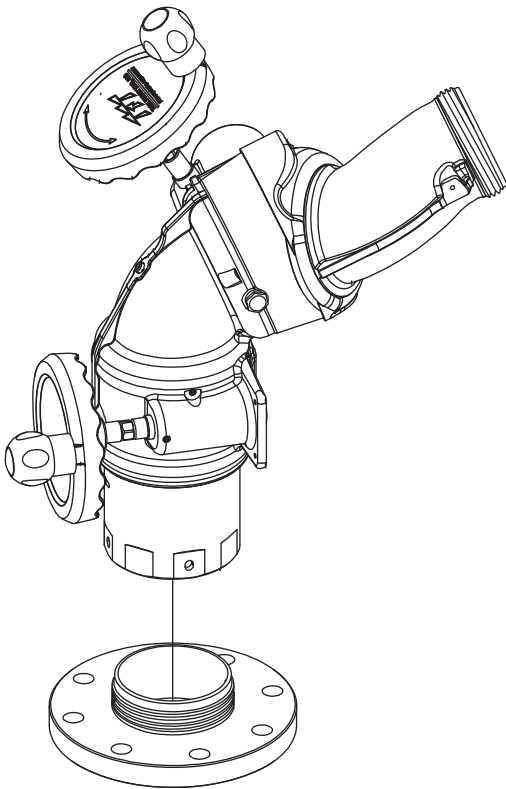

MONSOON

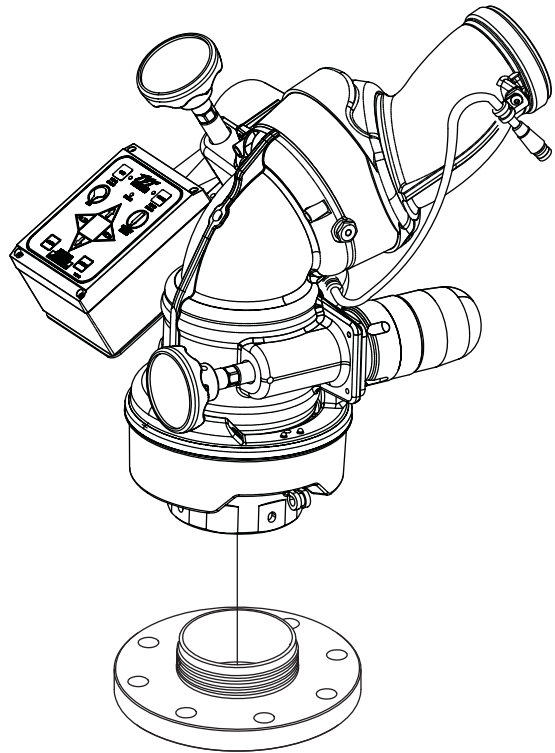

MONSOON RC

Maximum Recommended Flow is 2000 gpm (7600 l/min)
Maximum Recommended Pressure is 200 psi (14 bar)

TASK FORCE TIPS, INC.
MADE IN USA • www.tft.com

2800 East Evans Avenue, Valparaiso, IN 46383-6940 USA
800-348-2686 • 219-462-6161 • Fax 219-464-7155

DANGER

PERSONAL RESPONSIBILITY CODE

The member companies of FEMSA that provide emergency response equipment and services want responders to know and understand the following:

1. Firefighting and Emergency Response are inherently dangerous activities requiring proper training in their hazards and the use of extreme caution at all times.
2. It is your responsibility to read and understand any user's instructions, including purpose and limitations, provided with any piece of equipment you may be called upon to use.
3. It is your responsibility to know that you have been properly trained in Firefighting and/or Emergency Response and in the use, precautions, and care of any equipment you may be called upon to use.
4. It is your responsibility to be in proper physical condition and to maintain the personal skill level required to operate any equipment you may be called upon to use.
5. It is your responsibility to know that your equipment is in operable condition and has been maintained in accordance with the manufacturer's instructions.
6. Failure to follow these guidelines may result in death, burns or other severe injury.



Fire and Emergency Manufacturers and Service Association
P.O. Box 147, Lynnfield, MA 01940 • www.FEMSA.org

Table Of Contents

1.0 Meaning of Safety Signal Words.....	2	6.0 Flows and Pressures.....	13-16
2.0 Safety	3	6.1 Stacked Tips Flow and Reach	
3.0 General Information	3-7	6.2 Automatic Masterstream Nozzles	
3.1 Mechanical Specifications		6.3 Stream Straighteners	
3.2 Part Identification and Models		6.3.1 Stream Straighteners with Stacked Tips	
3.3 Inlets and Outlets		6.3.2 Stream Straighteners with Fog Nozzles	
3.4 Overall Dimensions		7.0 Maintenance and Inspection	17
4.0 Installation	8-12	7.1 Lubrication	
4.1 Structural Requirements for Monitor Mounting		7.2 Performance Testing	
4.2 Inlet Mounting and Travel Ranges		8.0 Troubleshooting	17
4.3 Nozzle Installation		9.0 Drawings and Parts List	18-22
4.4 Pressure Gage Port		9.1 Manual Monsoon	
4.5 Drain		9.2 Monsoon RC	
5.0 Operation	12-13	9.3 Monitor Control Box	
5.1 Horizontal Rotation Control		10.0 Warranty	Back Cover
5.2 Elevation Control			
5.3 Tiller Bar Model			
5.4 Recommended Park Position			
5.5 Override Knobs			

1.0 MEANING OF SAFETY WORDS

A safety related message is identified by a safety alert symbol and a signal word to indicate the level of risk involved with a particular hazard. Per ANSI standard Z535.6-2006, the definitions of the four signal words are as follows:

 **DANGER**

DANGER indicates a hazardous situation which, if not avoided, will result in death or serious injury.

 **WARNING**

WARNING indicates a hazardous situation which, if not avoided, could result in death or serious injury.

 **CAUTION**

CAUTION indicates a potentially hazardous situation which, if not avoided, may result in minor or moderate injury.

NOTICE

NOTICE is used to address practices not related to personal injury.

2.0 SAFETY

The operation of this monitor can be dangerous. The following must be observed at all times.

- WARNING** Injury or death may occur by attempting to use a damaged monitor. Before using the monitor inspect it for damage resulting from:
- Failure to drain monitor followed by exposure to freezing conditions
 - Exposure of monitor to temperatures in excess of 160 degrees F
 - Structural damage caused by over-pressurization
 - Missing parts, physical abuse, exposure to severe chemicals
 - Deformed or cracked flanges damaged as a result of improper installation
 - Excessive bolt torque
 - Wrong tightening sequence
- WARNING** Injury can result from an inadequately supported monitor. The monitor mount must be capable of supporting 1500 lbs (700 kg) of nozzle reaction force.
- WARNING** The stream exiting a monitor is very powerful and capable of causing injury and property damage. Make sure the monitor is securely attached to the base and pointing in a safe direction before water to the monitor is turned on. Use care in directing the stream.
- CAUTION** The electric Monsoon RC may be remotely operated. The electric drives are current limited but may still produce enough force to cause injury. Keep hands and fingers away from pinch points on the monitor.
- CAUTION** Do not use the manual override knobs while the electric controls are in operation. The electric drives produce enough torque to cause injury.
- CAUTION** Maximum flow and pressure is 2000 gpm (7600 l/min) and 200 psi (14 bar). Damage or injury may result if the monitor is operated beyond these limits.
- CAUTION** On many vehicle installations, the monitor is the highest point on the apparatus. Be sure there is sufficient clearance to safely pass under any doors or overhead obstructions. Always check parked position of the monitor before moving.

3.0 GENERAL INFORMATION

The Monsoon Monitor is a manually operated monitor designed for flows up to 2000 gpm (7,600 l/min). Maximum operating pressure is 200 psi (14 bar). Unique patent pending segmented waterway has only 15 psi (1 bar) friction loss at 2000 gpm. Water makes very few turns as it travels through the monitor resulting in low friction loss and a far reaching effective stream. Elevation range is 90 degrees above horizontal to 45 degrees below. Field changeable elevation travel stops at 45 degrees above, 30 degrees above, and 30 degrees below horizontal. The manual model has 360 degree continuous horizontal rotation with field changeable stops at 45, 90, and 135 degrees either side of a center position. Available with various inlet flanges and threaded fittings. Inlet also made for direct connection to TFT's electric Extend-A-Gun RC3 or RC4. Main waterway made from hardcoat anodized ANSI 356.0-T6 aluminum. Silver powder coat finish inside and out. Standard outlet is 3.5" NH (90 mm) rigid male thread.

The Monsoon RC is an electric remote controlled monitor that has all the benefits of the Monsoon monitor with the addition of powered operation. Designed for auto sense 12 VDC or 24 VDC operation. The Monsoon RC comes with a factory installed control panel mounted on the monitor for controlling horizontal rotation, elevation, and nozzle pattern. The motor control circuits are factory installed on the monitor and use position encoders and current limiting to protect the drive train at the ends of travel. Unit comes with ultra-flexing robotics cable already wired to the monitor so installation effort is minimized. Power wire has only four conductors (two for power and two for communications) further easing installation effort. Power wire is enclosed in a unique wire guide that allows 450 degrees of horizontal travel (225 degrees either side of a center position) which is far more reliable than slip rings or coil cords. Knobs for manual override are provided on the horizontal rotation and elevation drive. TFT's Master 2000 ER nozzle plugs into the factory installed nozzle power wire. Electric drives and control box are waterproof. Standard outlet is 3.5" NH (90 mm) rigid male thread.

3.1 MECHANICAL SPECIFICATIONS

Weight	Manual	25 lbs	11.4 kg
	Electric	37 lbs	16.8 kg
Min. Flow Area	4" Inlet	8.3 in ²	24.5 cm ²
	3" Inlet	7.07 in ²	45.6 cm ²
Max Flow		2000 gpm	7600 l/min
Max Operating Pressure		200 psi	14 bar
Materials Used	ANSI A356.0-T6 Aluminum, Stainless, Nylon		

3.2 PART IDENTIFICATION AND MODELS

The Monsoon Monitor comes in manual and electric remote controlled models. Manual models are available with either handwheel control on both axis or a tiller bar model that uses a tiller bar to control horizontal rotation. Electric remote control models are available in a standard model (suitable for on top of pumpers), a Ladder model and a Platform model. Compared to the standard model, the ladder or platform model uses smaller override knobs, has a smaller swing radius and has horizontal travel stops factory installed at 90° left and right (180° total). The various models of Monsoon monitors are shown in figures 3.2A, 3.2B, 3.2C and 3.2D. The monitor mounted control station on the standard remote controlled model is shown in figure 3.2E.

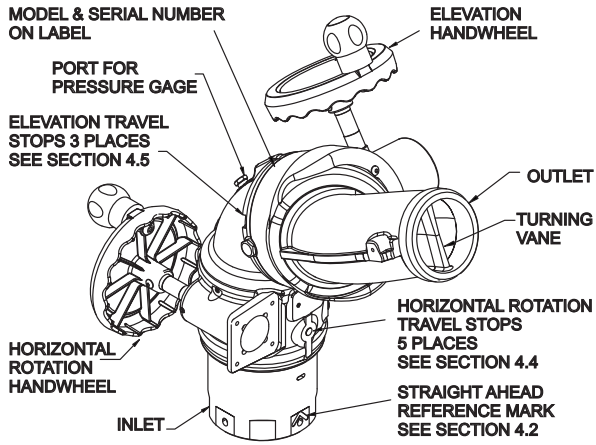

Figure 3.2A
Manual Handwheel Monsoon Monitor

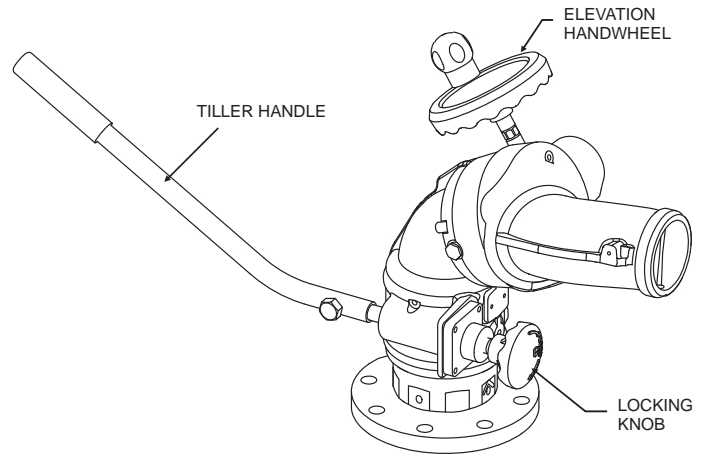

Figure 3.2B
Manual Tiller Bar Monsoon Monitor

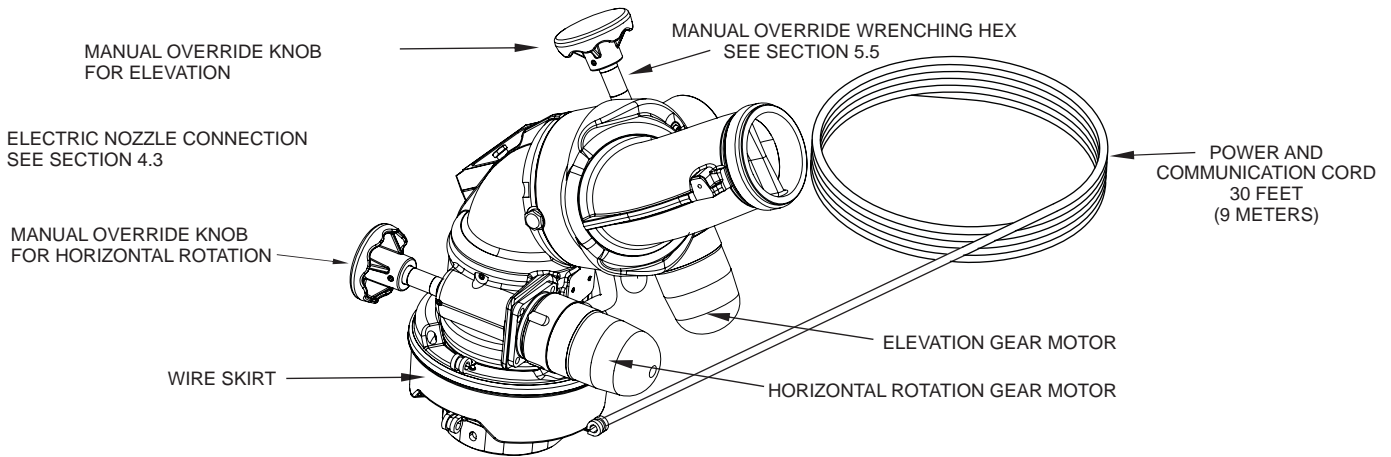

Figure 3.2C
Electric Monsoon RC Monitor

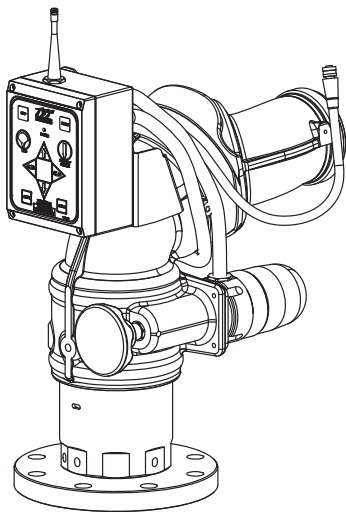

Figure 3.2D
Electric Monsoon RC for Ladders or Platforms

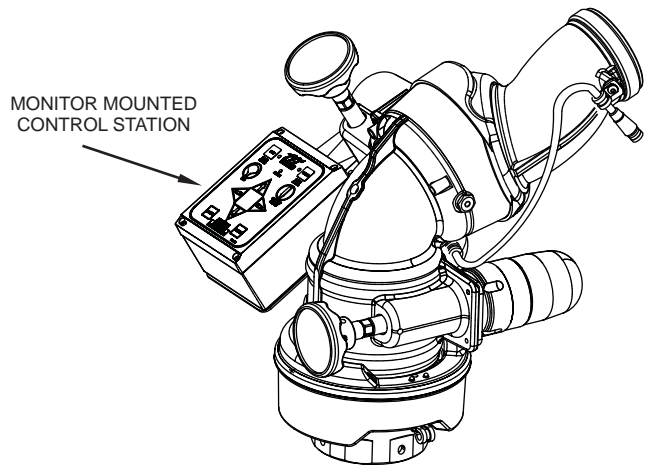
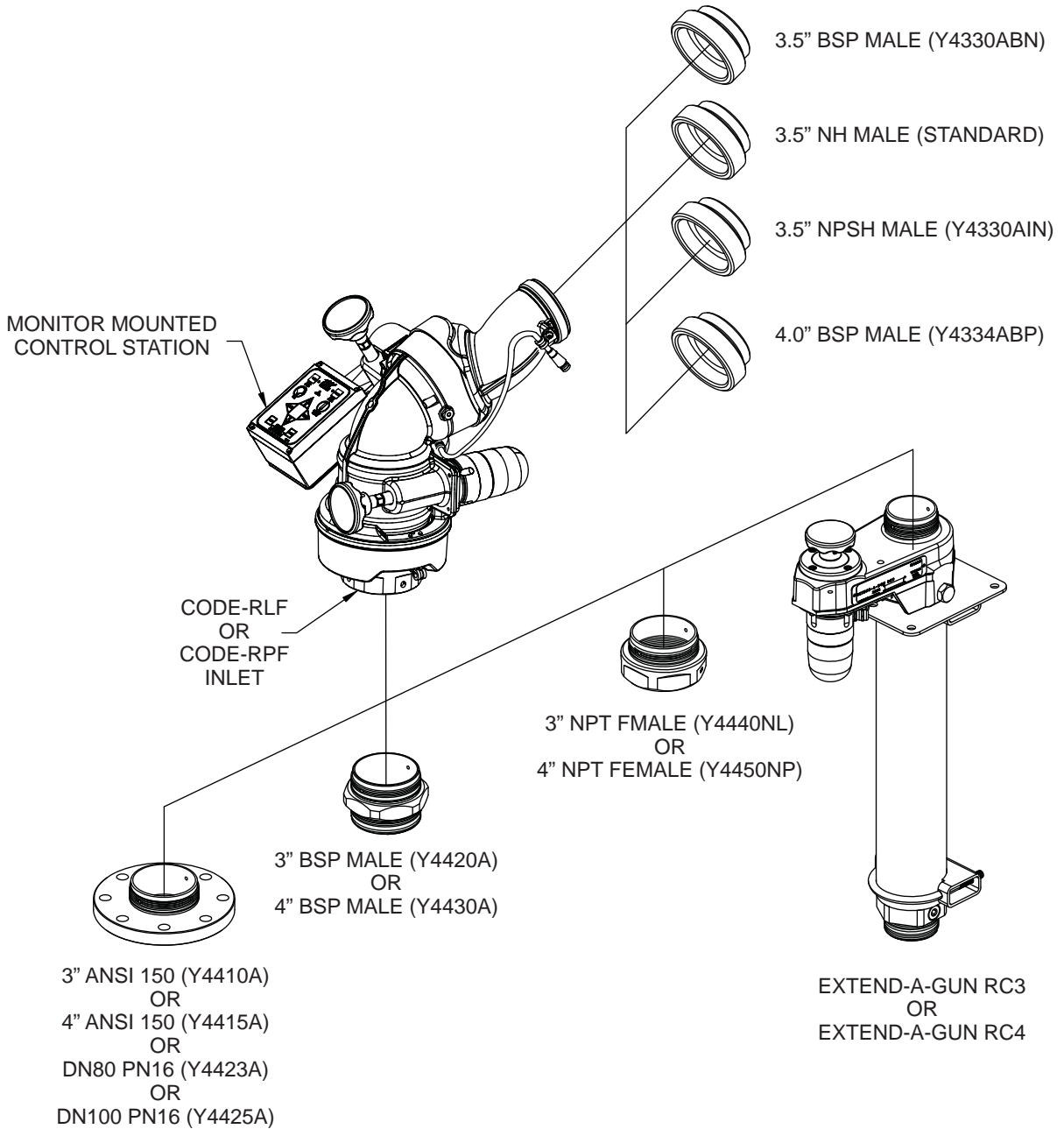

Figure 3.2E
Electric Monsoon RC Standard Model

3.3 INLETS AND OUTLETS

The standard Monsoon Monitor inlet is CODE-RPF for direct connection to TFT's Extend-A-Gun RC4 (4 inch size). Monitor inlet CODE-RLF is available for direct connection to Extend-A-Gun RC3 (3 inch size). The standard outlet is 3.5"-6 National Hose male. Various other inlet and outlet adapters are available as shown in figure 3.3.



FLANGE SIZE	OUTSIDE DIAMETER	THICKNESS	BOLT HOLE CIRCLE	NUMBER OF BOLTS	SIZE OF BOLTS	TORQUE ON BOLTS
3" ANSI 150	7.50"	.75"	6.00"	4	5/8"	76-80 FT-LBS
4" ANSI 150	9.00"	.94"	7.50"	8	5/8"	76-80 FT-LBS
Dn80 Pn16	200 mm	22 mm	160 mm	8	16 mm	100-110 NEWTON-METER
Dn100 Pn16	220 mm	22 mm	180 mm	8	16 mm	100-110 NEWTON-METER

Fig 3.3
Inlets and Outlets

3.4 OVERALL DIMENSIONS

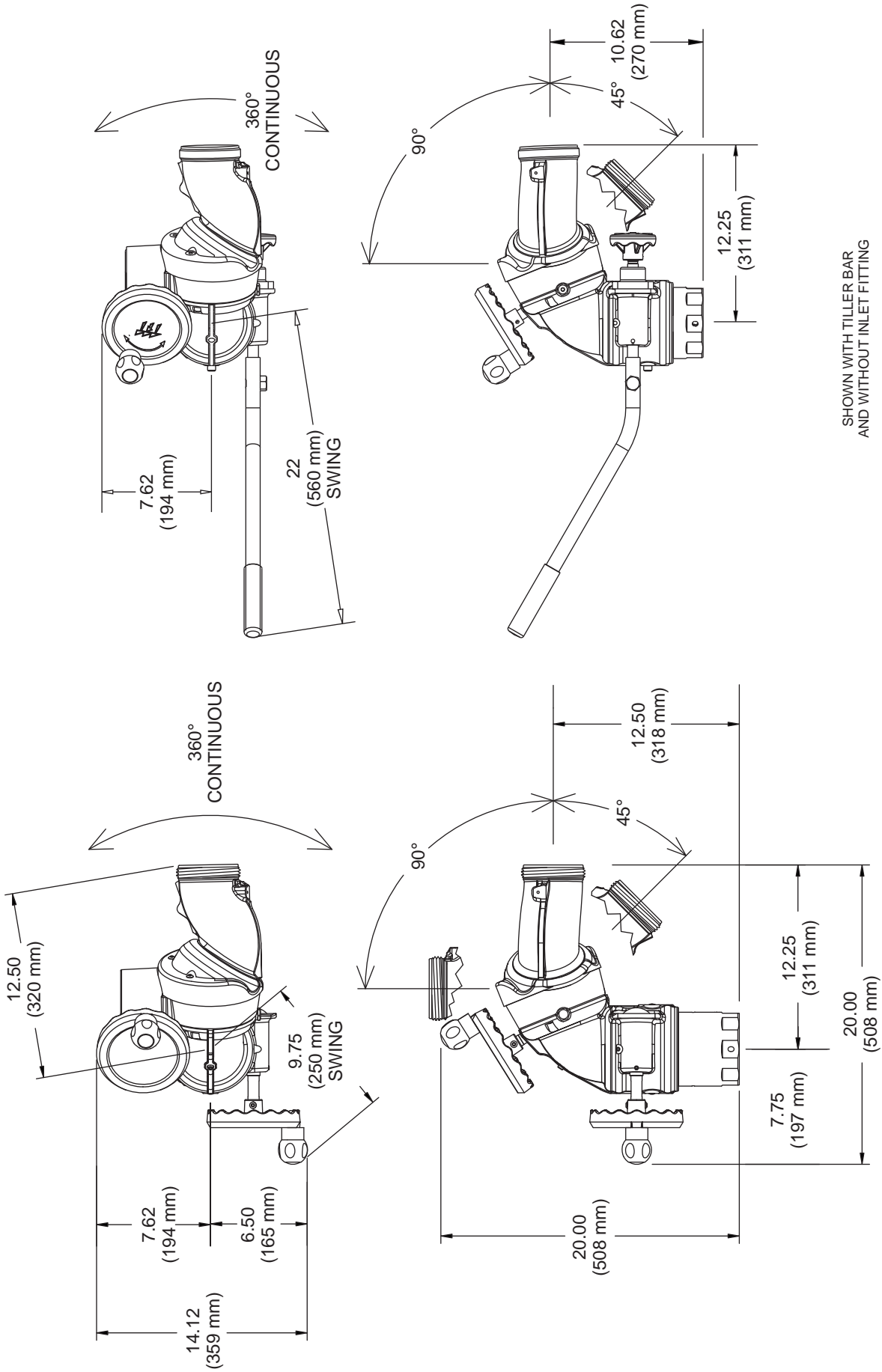

Manual Tiller Bar Monsoon Dimensions

Figure 3.4B

Manual Monsoon Dimensions

Figure 3.4A

3.4 OVERALL DIMENSIONS

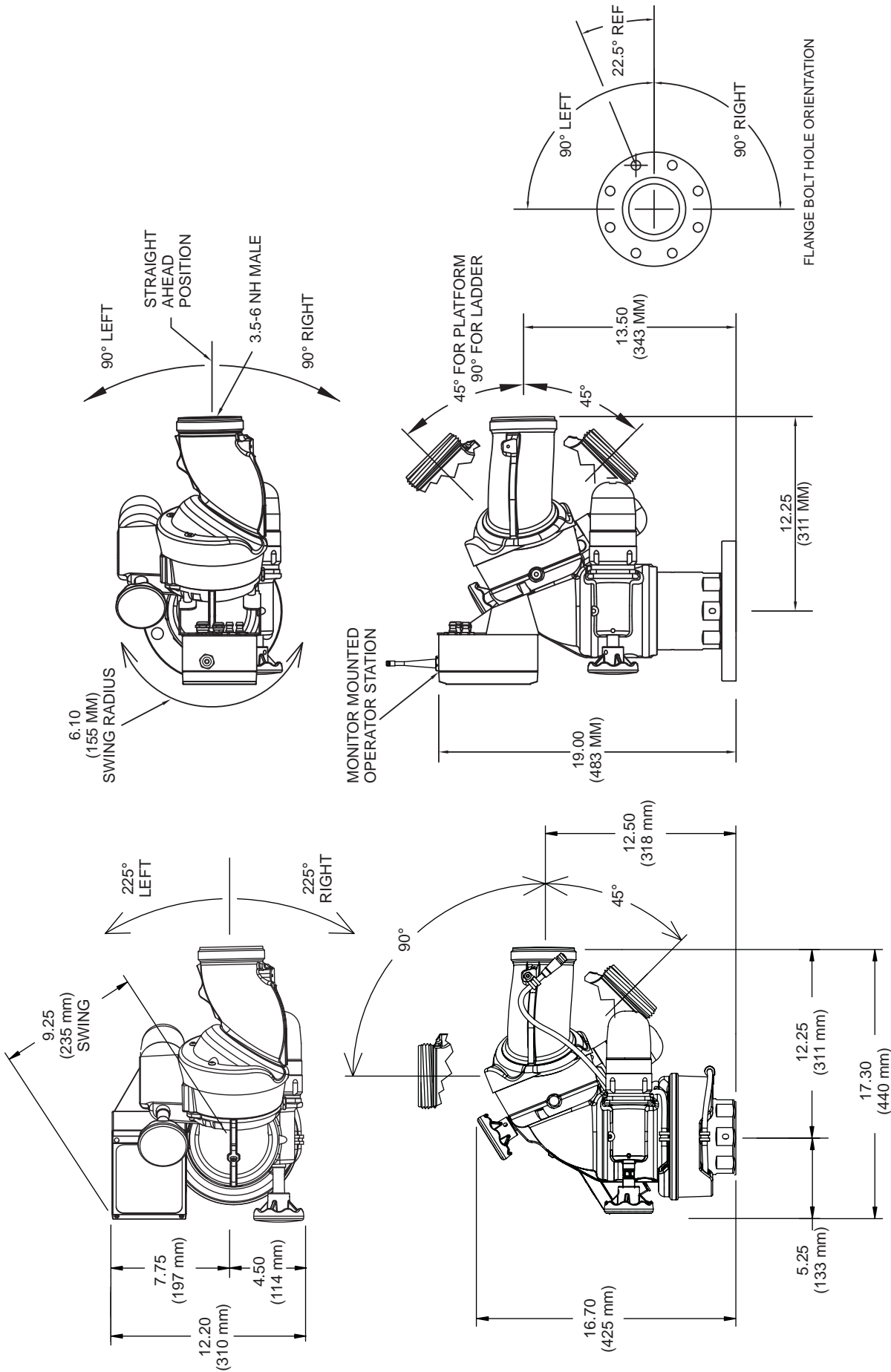

SHOWN WITHOUT INLET FITTING
SEE FIG. 4.2.1A FOR ADDITIONAL HEIGHT

Electric Monsoon RC For Ladder & Platform Dimensions

Figure 3.4D

Electric Monsoon RC Dimensions

Figure 3.4C

4.0 INSTALLATION

See Remote Control (RC) Monitor Electrical Controls Supplemental Instructions For Use With Tornado RC Models

4.1 STRUCTURAL REQUIREMENTS FOR MONITOR MOUNTING

The structure that the Monsoon Monitor is mounted to must withstand the internal pressure of the monitor as well as shear and bending forces due to nozzle reaction. Nozzle reaction can be as high as 1,500 lbs (700 kg) (2000 gpm at 200 psi).

For flanged connections the use of flat flanges without raised faces is recommended. Use a ring gasket as defined in ASME 16.21 or ISO 7483. Tighten flange bolts in an alternating sequence as shown in figure 4A. Tighten to 76-80 ft-lb (100-110 Newton-Meters).

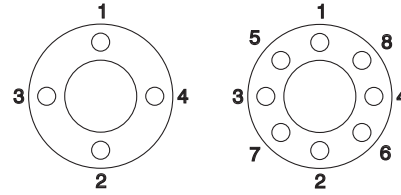

Tighten sequentially each bolt three times.

Fig 4.1 Flange Bolt Tightening Sequence



Injury can result from an inadequately supported monitor. The monitor mount must be capable of supporting the nozzle reaction force which can be as high as 1500 lbs (700 kg). Flanges and pipe made from plastic are inadequate for monitor mounting and must not be used. This monitor is not recommended for portable use.

4.2 INLET MOUNTING AND TRAVEL RANGES

4.2.1 INLET FITTING OR EXTEND-A-GUN RC INSTALLATION

The Monsoon Monitor is available with various inlet fittings as shown in fig 3.3. When the inlet fittings are used see figure 4.2.1A for the addition to overall height. The Monsoon Monitor also connects directly to TFT's Extend-A-Gun RC3 or RC4. The fittings and Extend-A-Gun RC are attached to the monitor by means of a threaded joint with an o-ring seal. Once in the proper orientation the threaded joint is locked from rotation by two 1/4-28 button head cap screws as shown in figure 4.2.1B. This makes for easy removal of the monitor since the large threads of the joint are not tightened and do not have any thread locking compounds on them. It is best to install the inlet fitting or Extend-A-Gun RC to the apparatus and then install the monitor to the inlet fitting or Extend-A-Gun RC. This gives more room to install the bolts in the case of flanged fittings. Referring to figures 4.2.1B and 4.2.1C the installation sequence is as follows:

- 1) Install inlet fitting or Extend-A-Gun RC to apparatus.
 - Mount so that 180 degree apart threaded cross holes will give desired direction relative to the "Straight Ahead Reference Mark" when the monitor is installed. See figure 4.2.1B.
- 2) Screw monitor onto inlet fitting or Extend-A-Gun RC until threaded joint bottoms out.
 - Do not use pipe dope or Loctite on the inlet base threads. These threads are sealed with an o-ring. The use of thread locking compounds will make removal difficult.
- 3) Unscrew monitor slightly until a pair of 90 degree apart slots lines up with the 180 degree apart threaded cross holes in the inlet fitting or Extend-A-Gun RC.
 - Orient monitor so that the Straight Ahead Reference Mark is facing the desired direction.
 - Slots will line up with threaded cross holes every 90 degrees of rotation.
 - Monitor may be unscrewed up to one full turn from the bottomed out position.
- 4) Install 1/4-28 by 1/2 long button head cap screws and washers in the two threaded cross holes. Use Loctite #271 on the threads of the button head cap screws. Allow Loctite to fully cure before applying water pressure.

MODEL	INLET FITTING TYPE	ADDITIONAL HEIGHT
Y4-*1*A	3" ANSI 125/150 DN8, PN20	0.75" 20mm
Y4-*2*A	4" ANSI 150 DN100, PN20	0.94" 24mm
Y4-*4*A	DN80, PN16	0.75" 20mm
Y4-*5*A	DN100, PN16	0.94" 24mm
Y4-*6*A	3" NPT FEMALE	2.00" 51mm
Y4-*7*A	4" NPT FEMALE	1.75" 45mm
Y4-*8*A	3" BSP MALE	2.30" 58mm
Y4-*9*A	4" BSP MALE	2.30" 58mm

Fig 4.2.1A
Additional Height for Inlet Fittings

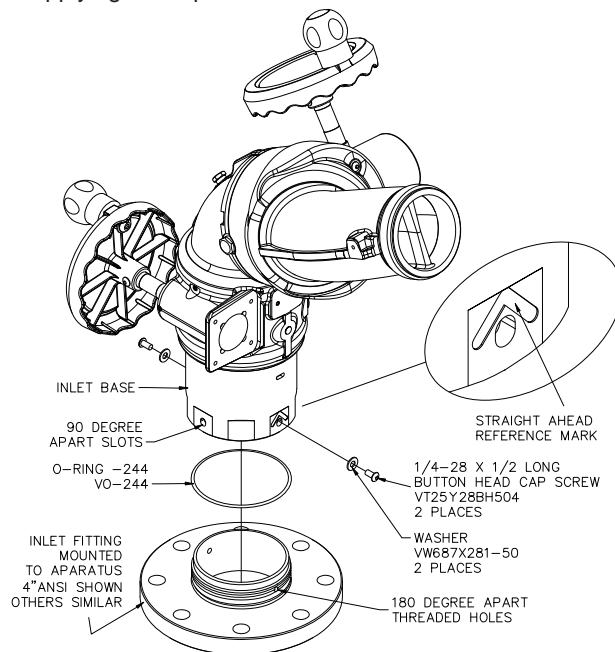

Fig 4.2.1B
Inlet Fittings Connection

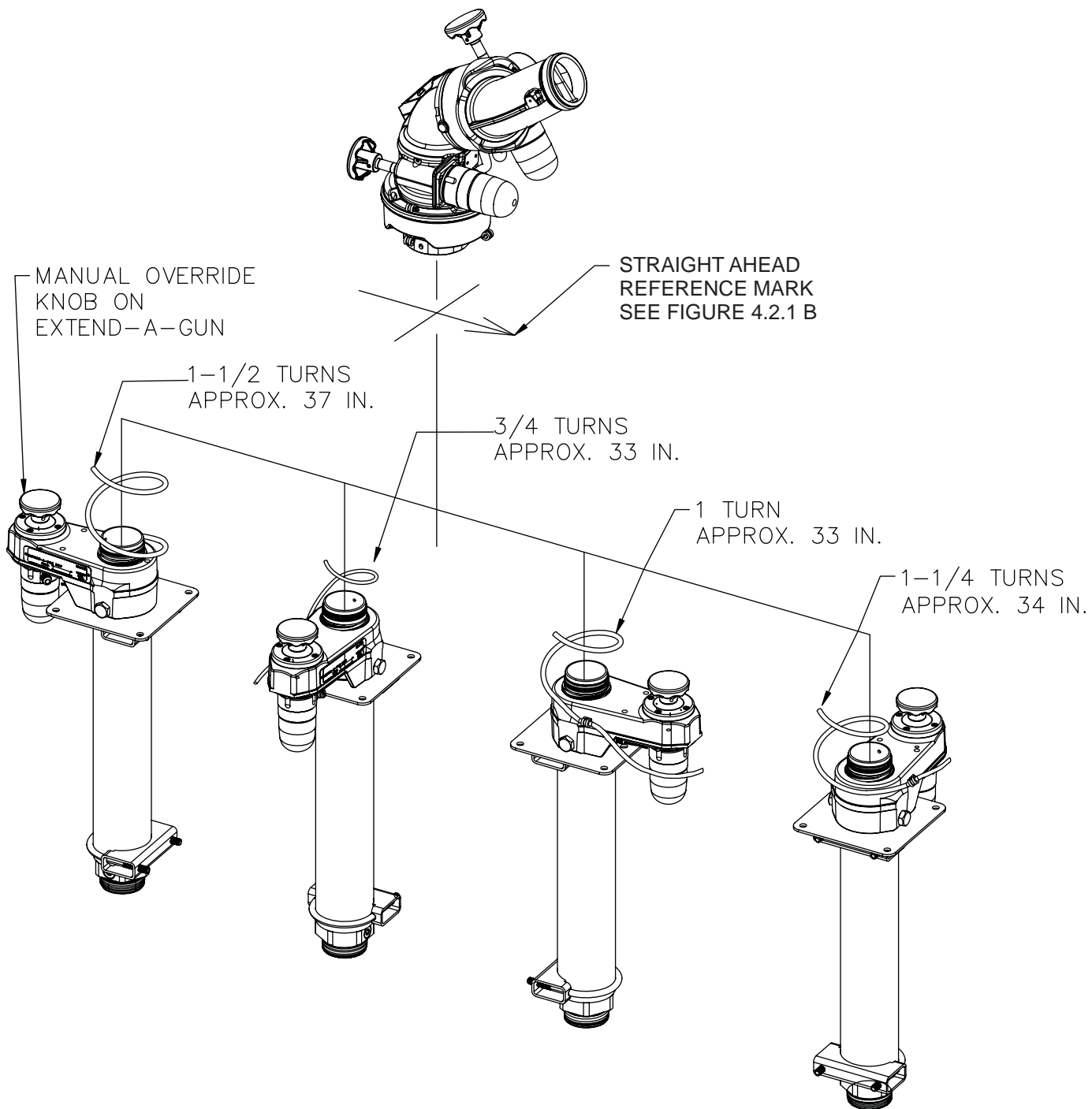

Fig 4.2.1C Possible Extend-A-Gun RC Mounting Orientations

The Extend-A-Gun manual override knob may be mounted in any of four possible orientations (90 degrees apart) relative to the Straight Ahead Reference Mark on the monitor.

NOTE: Monsoon monitor, for use with Extend-A-Gun RC, comes with the wire installed in a nylon tube. The nylon tubing gives the wire additional stiffness so it better follows as the Extend-A-Gun RC extends or retracts. A fitting is also supplied and is to be used where the nylon tubing and wire pass through the deck.

4.2.2 HORIZONTAL ROTATION TRAVEL STOPS

The range of horizontal rotation travel for the manual Monsoon monitor is continuous 360 degrees. The motorized version is limited to 450 degrees total horizontal rotation travel or 225 degrees from either side of a straight ahead position. Horizontal rotation travel stop bolts may be installed in the monitor to limit travel as shown in figures 4.2.2A and 4.2.2B. Note that left and right are relative to the "Straight Ahead Reference Mark" (the Straight Ahead Reference Mark is shown in figures 4.2.2A and 4.2.2B) and refer to the nozzle's discharge direction as seen from an operator's position behind the nozzle. Figures 4.2.2A and 4.2.2B show the range of travel for the various stop bolt locations and give installation notes.

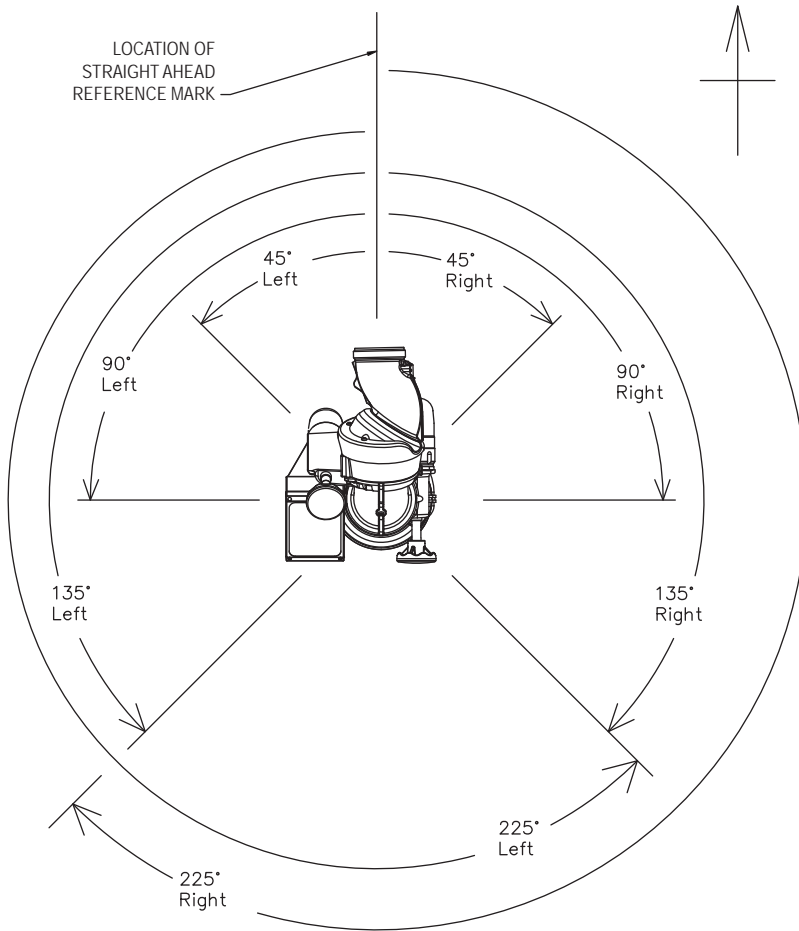

Electric model with no stop bolts installed has 225° left and right horizontal rotation travel limits.

Manual model with no stop bolts installed has continuous 360° horizontal rotation travel.

Fig 4.2.2A
Horizontal Rotation Travel Limits

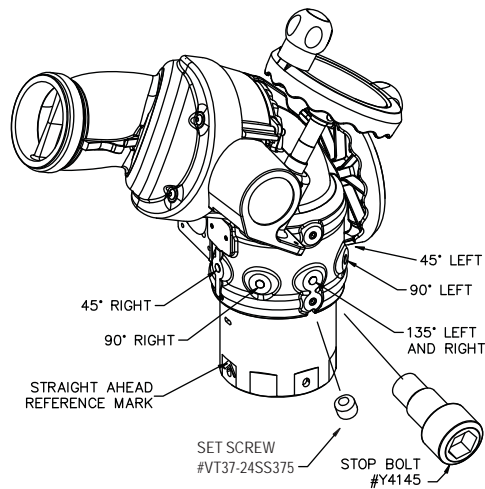

Remove set screw and install Stop Bolt to obtain desired travel limits.

Fig 4.2.2B
Horizontal Rotation Travel Stop Locations

4.2.3 ELEVATION TRAVEL STOPS

The range of elevation travel for the Monsoon Monitor is 90 degrees above zero to 45 degrees below zero. The elevation range may be limited by installing the supplied stop bolts at the locations shown in figures 4.2.3A and 4.2.3B. Consult factory for other ranges. The figures include installation notes.

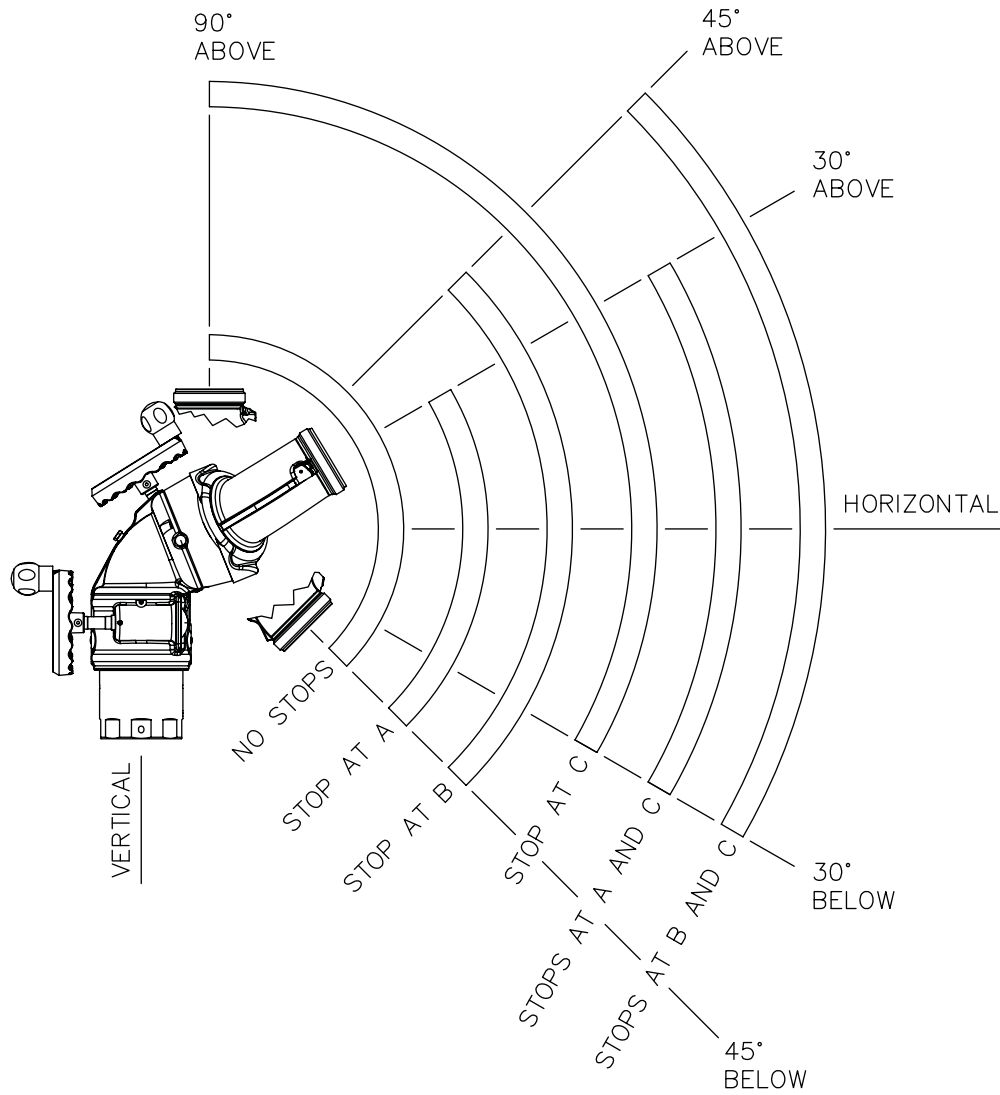

Fig 4.2.3A
Elevation Travel Limits

Pry out plastic plug and install Stop Bolt to obtain desired travel limits.
Elevation travel with no Stop Bolts is 90° above and 45° below zero.

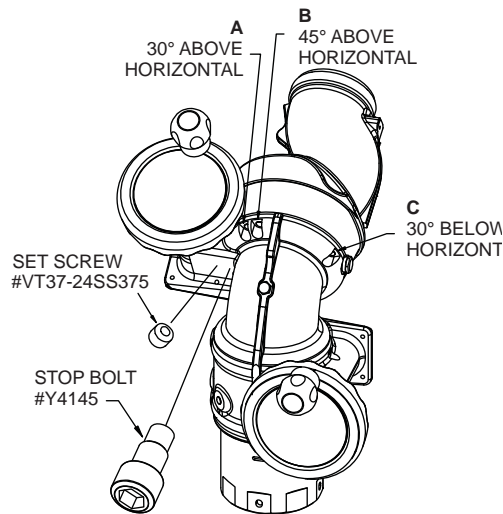

Fig 4.2.3B
Elevation Travel Stop Locations

4.3 NOZZLE INSTALLATION

The nozzle is simply screwed onto the monitor's exit threads. If the nozzle is installed on a Monsoon RC (with electric motors) assure that the nozzle's coupling does not make contact with the horizontal drive motor housing when the monitor is in its lowest elevation position.

For nozzles with electric pattern control, a cable with a female, waterproof connector is provided at the outlet of the Monsoon RC which attaches directly to TFT's electric Masterstream 1250, 1500 or 2000 nozzle. The cable used is a dual-key, micro type plug assembly. Any other nozzle should have the corresponding male electrical connector installed. Do not cut off the female connector on the monitor. This connector is molded onto the cable and must remain in place to maintain the water tightness of the electrical system.



The nozzle threads must match the threads of the Monsoon monitor in both size and type. Mismatched or damaged threads may cause the nozzle to leak or uncouple under pressure and could cause injury.



Do not connect aluminum to brass or brass to aluminum. Dissimilar metals coupled together can cause galvanic corrosion that will freeze the threaded joint or cause complete loss of thread engagement. If dissimilar metals must be coupled together, the effects of corrosion can be greatly delayed by various coatings on the metal such as powder paint, hard anodizing, or silicone grease.

4.4 PRESSURE GAGE PORT

There is a 1/4" NPT female threaded hole on the back of the monitor. The hole is plugged from the factory. If a pressure gage is desired, unscrew the plug and install the gage using pipe sealant. Make sure the gage does not interfere with the elevation handwheel.

4.5 DRAIN

There is no drain on the Monsoon Monitor itself. A drain valve should be installed on the monitor's inlet piping.

5.0 OPERATION

5.1 HORIZONTAL ROTATION CONTROL

A handwheel controls the monitor's horizontal rotation direction. Clockwise rotation of the handwheel moves the nozzle to the left and counter-clockwise rotation to the right. Approximately 14 turns of the handwheel will give a 90 degree change in horizontal rotation direction.

5.2 ELEVATION CONTROL

A handwheel controls the monitor's elevation direction. Clockwise rotation of the handwheel raises the elevation and counter-clockwise lowers it. About 50 turns of the handwheel will give the complete 135 degree elevation travel range of the monitor.

5.3 TILLER BAR MODEL

On the Tiller Bar model the horizontal rotation is changed by pushing or pulling horizontally on the Tiller Handle. Twisting the Rotation Locking Knob clockwise will increase the drag on the lower swivel joint to "lock" the monitor in a particular direction. See figure 5.3 for the Tiller Bar model controls.

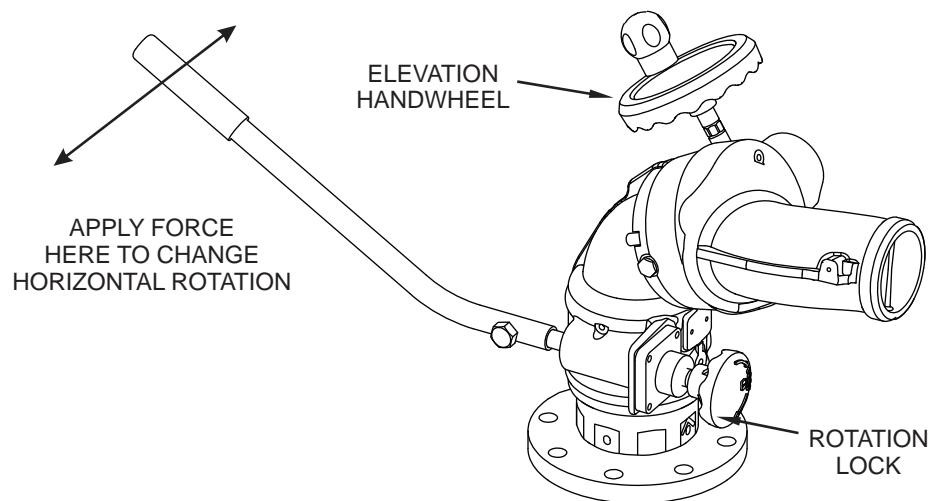

Figure 5.3
Tiller Bar Model Controls



Injury can result from the monitor changing direction due to an off center nozzle reaction. An off center nozzle reaction may be caused by debris in the nozzle causing an asymmetrical stream. Always keep the rotation lock tight when not rotating the monitor. Always keep one hand on the tiller handle when loosening the locking knob. Where continuous 360 degree rotation of the monitor is not needed it is recommended that the Horizontal Rotation Stop Bolts (see section 4.2.2 for Stop Bolt locations) be installed to reduce any chance of the monitor spinning due to an off center nozzle reaction caused by debris trapped in the nozzle.

5.4 RECOMMENDED PARK POSITION

For truck mounted applications it is recommended that the monitor be parked in a position such that the monitor's nozzle rests against a bracket or support surface. If a support surface is not available, run the elevation against one of its travel stops to take some of the backlash out of the gear drive. This will minimize bouncing of the nozzle when the apparatus is traveling. Always be sure the monitor is properly parked before moving the truck and know the overall height to avoid damage from overhead obstructions such as doors or bridges.

5.5 OVERRIDE KNOBS

In the event of electrical system failure on the monitor or fire truck the Monsoon Monitor is factory supplied with knobs so the monitor may be manually operated. To make the Monsoon RC more compact the manual override knobs may be removed. The drive shafts have a hex so a wrench or socket may be used for manual override. Each drive shaft also has a secondary hex at mid shaft so the shaft may be shortened by cutting and still have a wrenching hex. The wrenching hexes are shown in figure 5.5.

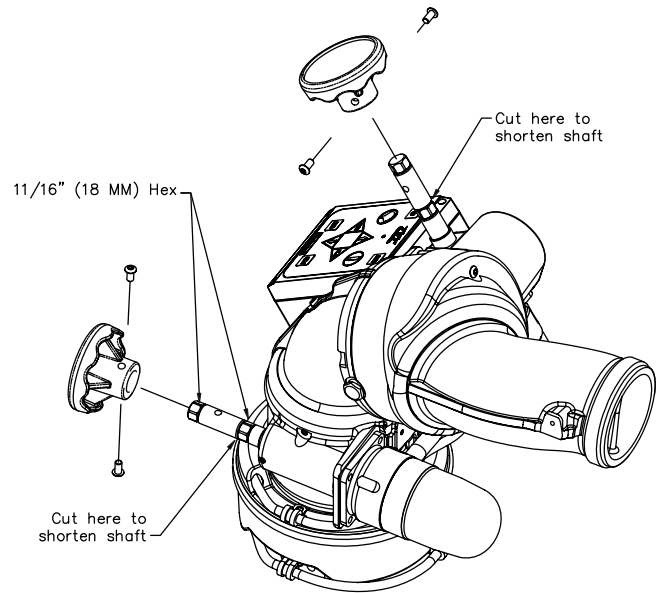

Fig 5.5
Wrenching Hexes on Drive Shaft

6.0 FLOWS AND PRESSURES

6.1 STACKED TIPS FLOW AND REACH

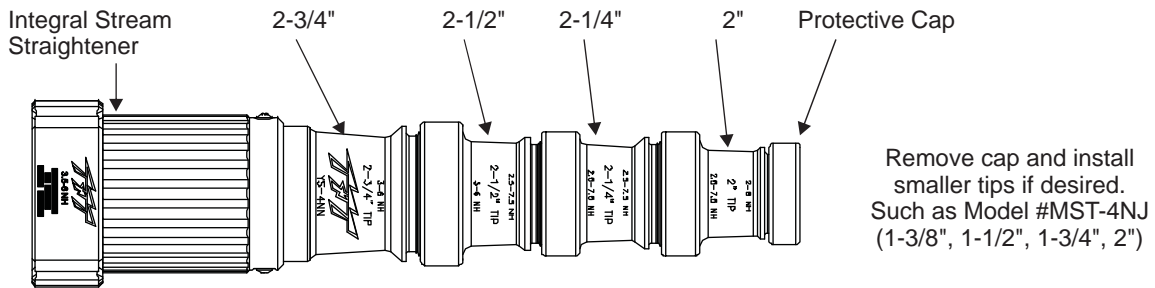

Fig 6.1A
Stacked Tip Model YST-4NN

Nozzle Diameter (inches)	Nozzle Pressure (PSI)							
	50		60		80		100	
	Flow GPM	Reaction lbf	Flow GPM	Reaction lbf	Flow GPM	Reaction lbf	Flow GPM	Reaction lbf
2	840	310	920	380	1060	500	1190	630
2.25	1060	400	1170	480	1350	640	1500	790
2.5	1310	490	1440	590	1660	790	1860	980
2.75	1590	590	1740	710	2010	950	-----	-----

14.5 psi = 1 bar
1 gpm = 3.785 l/min

Nozzle Diameter (MM)	Nozzle Pressure (BAR)							
	3.5		4.1		5.5		7	
	Flow l/min	Reaction kg	Flow l/min	Reaction kg	Flow l/min	Reaction kg	Flow l/min	Reaction kg
50	3180	140	3480	170	4010	230	4500	290
57	4010	180	4430	220	5110	290	5680	360
64	4960	220	5450	270	6280	360	7040	450
70	6020	270	6590	320	7610	430	-----	-----

Fig 6.1B
Stacked Tip Flow Table

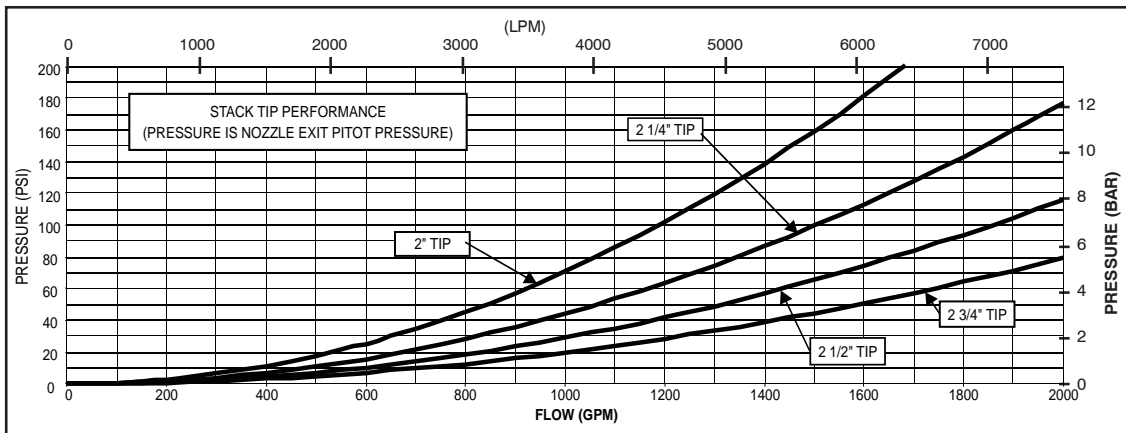

Fig 6.1C Stacked Tip Flow Graph

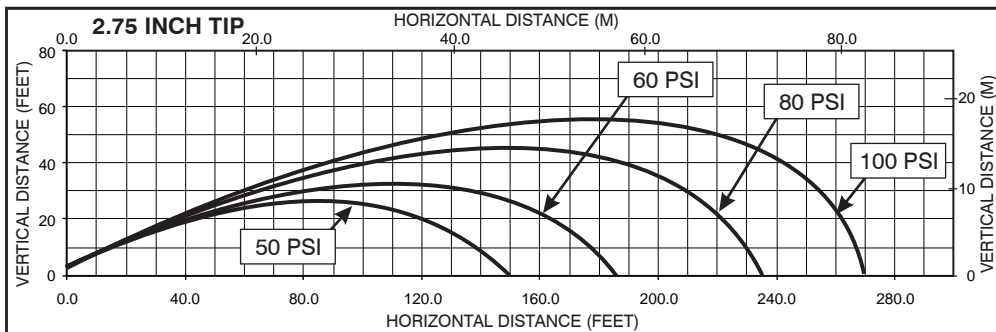
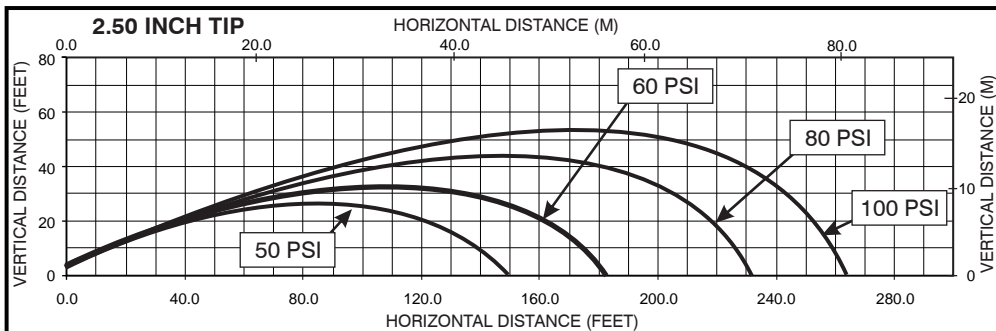
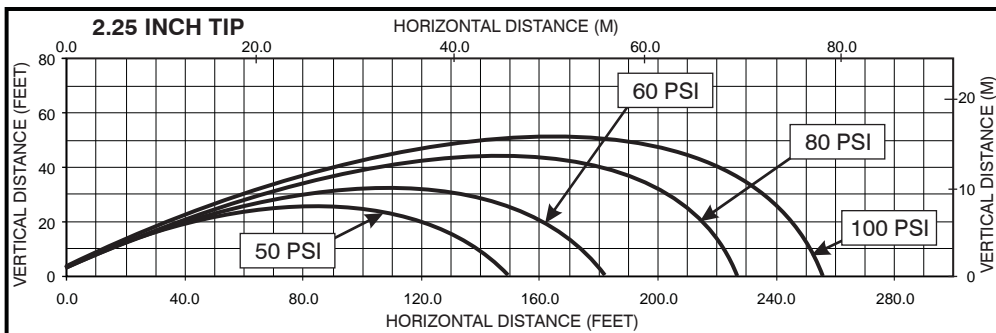
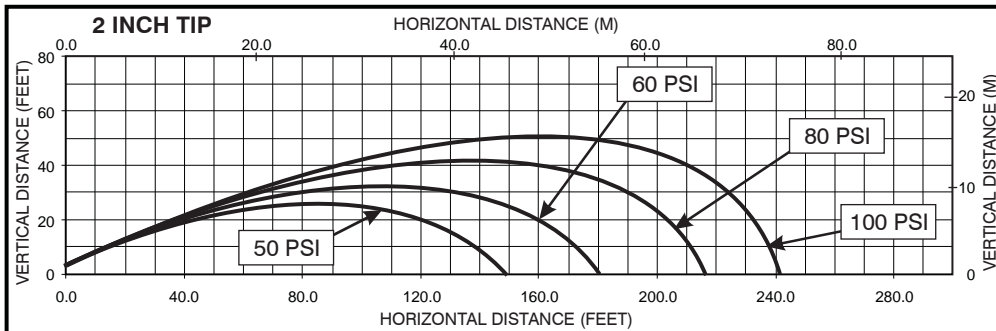

Fig 6.1D Stacked Tip Stream Trajectory Graphs

This graph is approximate only. Critical applications should be tested in actual conditions to verify adequate reach.

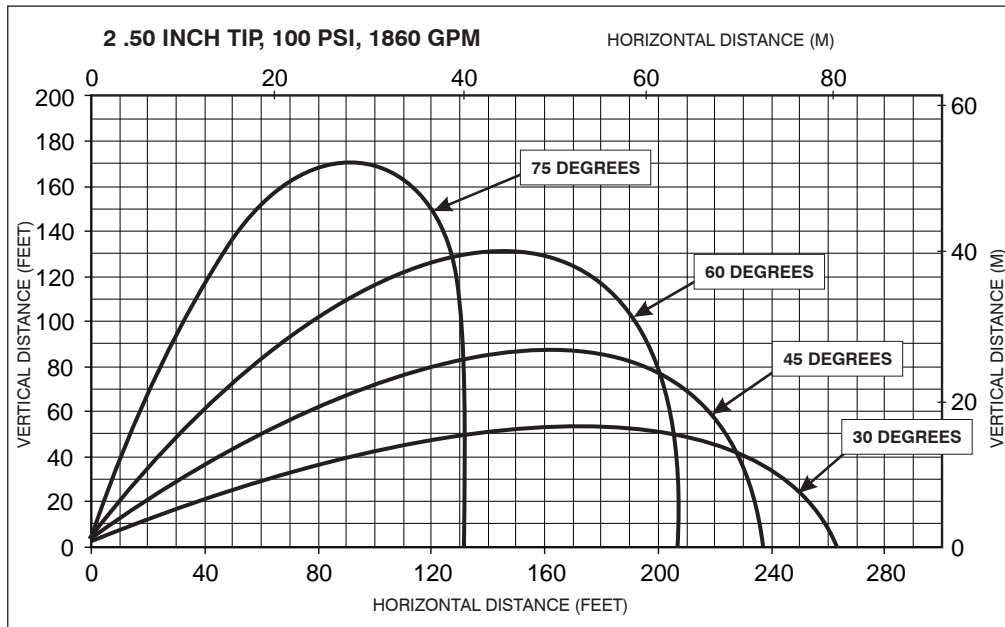

Fig 6.1E
Effects of Elevator Trajectory

This graph shows approximately how a moderate wind can affect stream reach. 1 ft = 0.3048 m

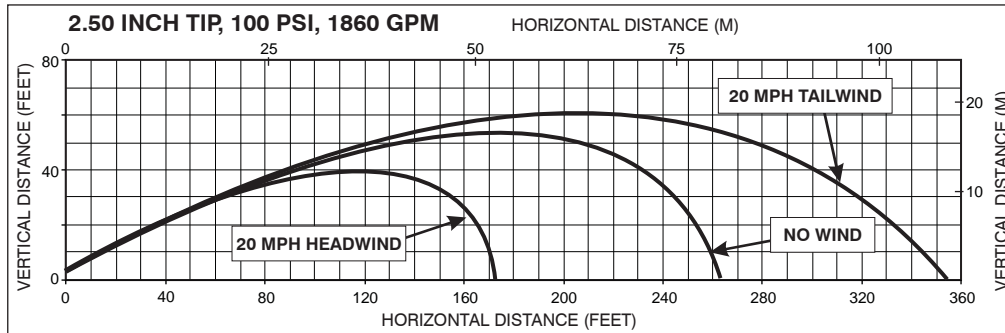

Fig 6.1F
Effects of Wind on Reach

6.2 AUTOMATIC MASTERSTREAM NOZZLES

Automatic nozzles maintain a constant pressure by adjusting their orifice to match the available flow. Consult the nozzle manufacturer for maximum flow and pressure range. In all cases do not exceed 2000 gpm (7,600 LPM). TFT's Masterstream 2000 nozzle has a 300-2000 gpm flow range. Masterstream 2000 Nozzle operating instructions (Item Number LIM-030) is available on TFT's website: www.tft.com

6.3 MONSOON MONITOR FRICTION LOSS

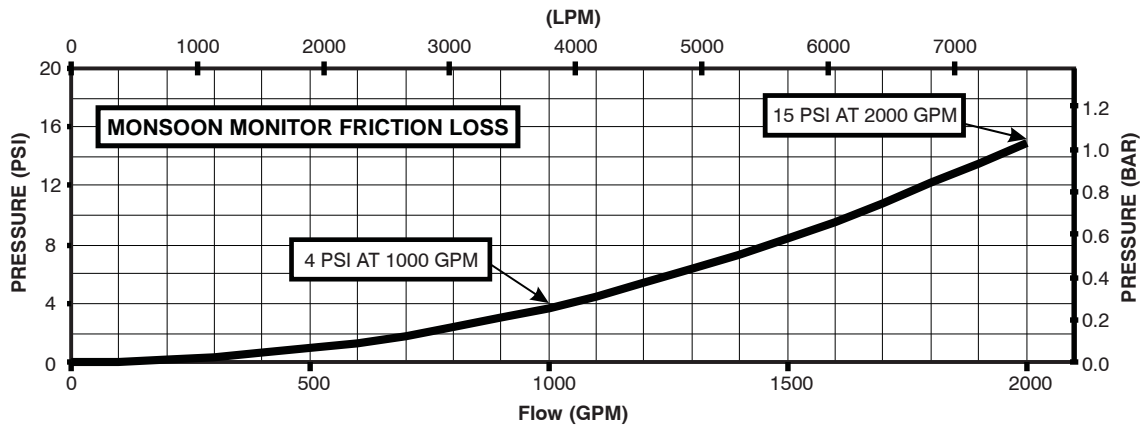

Fig 6.3
Monsoon Monitor Friction Loss

6.4 STREAM STRAIGHTENERS

6.4.1 STREAM STRAIGHTENERS WITH STACKED TIPS

Turbulence through the Monsoon Monitor is very low but stream quality and reach can be improved with the use of the integral stream straightener on the TFT stacked tip nozzle. See figure 6.4 for the stacked tip's integral stream straightener friction loss.

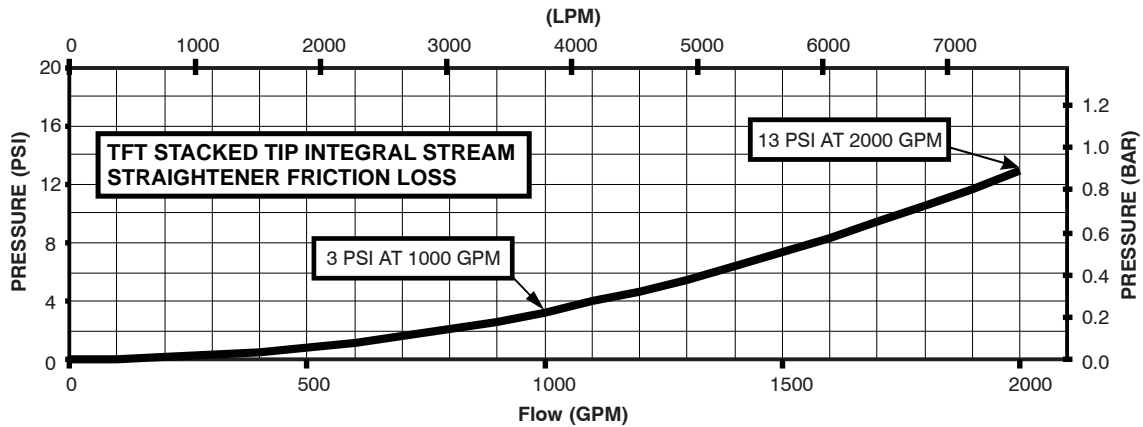
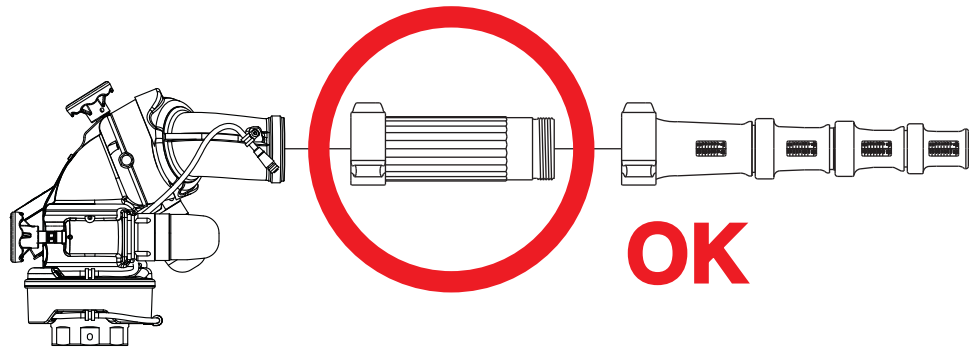
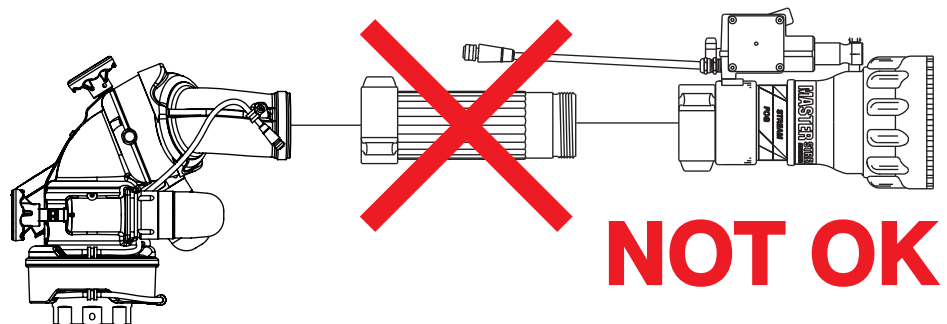

Fig 6.4
TFT Stack Tip Integral Stream Straightener Friction Loss

6.4.2 STREAM STRAIGHTENERS WITH FOG NOZZLES

When using a fog nozzle it is recommended that no stream straightener be used since the fog nozzle's flow path generally serves as a stream straightener. Use of a stream straightener with a fog nozzle will increase the stresses on the monitor's gear train and may lead to premature wear.



7.0 MAINTENANCE AND INSPECTION

The Monsoon Monitor requires little maintenance. The monitor should be kept clean and free of dirt. All controls should be checked for freedom of movement and proper operation before each use. Consult factory for recommended service procedure. Any inoperable or damaged parts should be repaired or replaced immediately.

- Make sure that the monitor's handwheels rotate freely and without binding throughout its range of travel.
- Make sure that there are no leaks when the monitor is flowing water.
- Make sure the nozzle is free of debris.

7.1 LUBRICATION

The Monsoon monitor generally should not require greasing. In the event that the operation becomes stiff grease may be applied to the horizontal rotation and elevation worm gears. The grease is applied by removing the plugs at the grease ports and replacing with grease fittings that have ¼-28 male threads. See figures 7.1A and 7.1B for grease port locations. Use medium viscosity automotive chassis grease. Apply only enough grease to restore normal operation. If normal operation is not restored by greasing than inspect for other causes of stiff operation.

Note: Do not over pump grease. The monitor's greased areas lead to large chambers that could trap several pounds of grease before becoming visible.

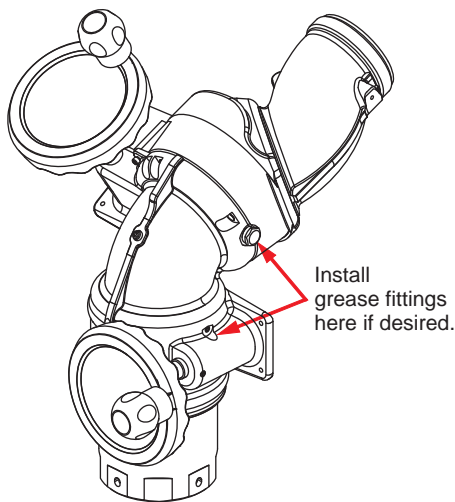

Fig 7.1A
Location of Grease Port for Horizontal Rotation
Worn Gear and Elevator Joint

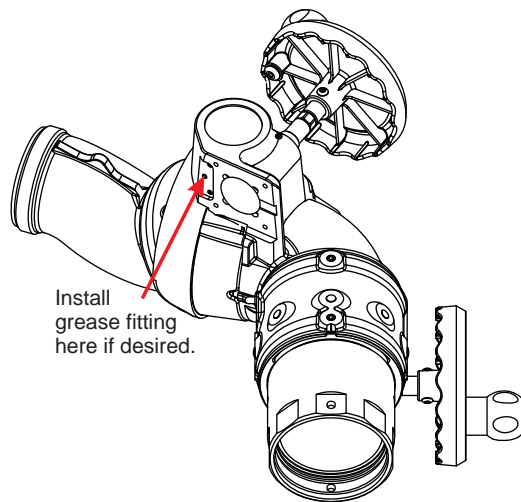

Fig 7.1.B
Location for Grease Port
for Elevation Worm Gear

7.2 PERFORMANCE TESTING

Performance tests should be conducted on the Monsoon Monitor after repairs are made, or any time a problem is reported to verify operation in accordance with Task Force Tips test procedures. Consult the factory for the test procedure that corresponds to the model and serial number of your monitor. Any equipment that fails the test criteria should be removed from service immediately. Equipment can be returned to the factory for service and testing.

8.0 TROUBLESHOOTING

SYMPTOM	POSSIBLE CAUSE	REMEDY
Leaks	Debris or damage in seal area	Clean out debris or replace damaged parts
Elevation Binding	Debris or damage to elevation drive parts	Clean out debris or replace damaged parts
	Lack of lubricant	Grease, see section 7.1
Horizontal Rotation Binding	Debris or damage to horizontal drive parts	Clean out debris or replace damaged parts
	Lack of lubricant	Grease, see section 7.1

9.0 MONSOON DRAWING & PARTS LIST

9.1 MANUAL MONSOON DRAWING & PARTS LIST

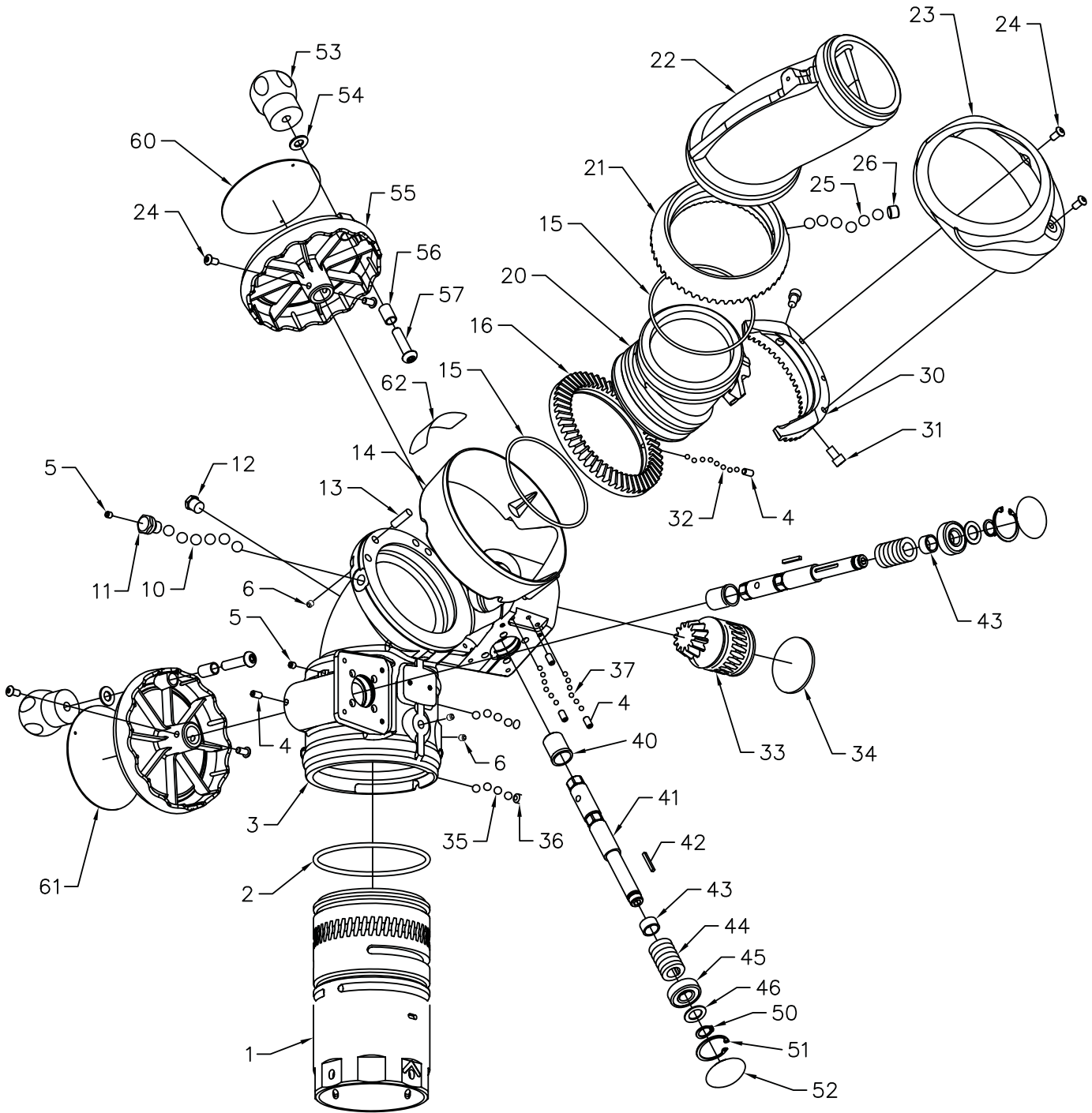

Fig 9.1
Monsoon Mechanical Parts Exploded View

MANUAL MONSOON PARTS LIST

#	DESCRIPTION	QTY	PART #
1	BASE CODE-RPF 4" -ALUMINUM	1	Y4400A
	BASE CODE-RLF 3" -ALUMINUM		Y4405A
2	O-RING -350 4 5/8 ID 3/16 C/S	1	VO-350
3	LOWER SEGMENT -ALUMINUM	1	Y4110A
4	1/4-28 X 1/2 SOCKET SET SCREW CUP POINT	5	VT25-28SS500
5	1/4-28 X 1/4 SOCKET SET SCREW	2	VT25-28SS250
6	3/8-24 x 3/8 SOCKET SET SCREW CUP POINT	8	VT37-24SS375
10	BALL 7/16" TORLON	32	VB437TO
11	BALL PORT PLUG	1	Y4155
12	1/4 NPT PLUG - HEX SOCKET	1	VFSP2M-SS
13	DOWEL PIN .3127+-.0001 DIA 1.00+-.012 LG	1	VP312X1.00
14	LOWER SHROUD	1	Y4130
15	O-RING-245 4-3/8 ID 1/8 C/S	2	VO-245
16	LOWER RING GEAR	1	Y4220
20	MIDDLE SEGMENT -ALUMINUM	1	Y4210A
21	UPPER RING GEAR	1	Y4320
22	UPPER SEGMENT -ALUMINUM	1	Y4310A
23	UPPER SHROUD	1	Y4240
24	1/4-20 X 3/8 BUTTON HEAD CAP SCREW	6	VT25-20BH375
25	BALL 7/16" TORLON	32	VB437TO
26	1/2-20 X 3/8 SOCKET SET SCREW CUP POINT	1	VT50-20SS375
30	HALF RING GEAR	1	Y4230
31	5/16-18 X 1/2 SOCKET HEAD CAP SCREW	2	VT31-18SH500
32	3/16" BALL - TORLON	74	V2120-TORLON
33	PINION	1	Y4120
34	PLUG 2-1/4 MOUNTING HOLE	1	Y4162
35	BALL 5/16" TORLON	49 X 2 RACES	VB.312TO
36	3/8-24 X 5/16 SOCKET SET SCREW CUP POINT	2	VT37-24SS312
37	3/16" BALL - TORLON	36 X 2 RACES	V2120-TORLON
40	HEADED BUSHING	2	Y4141
41	DRIVE SHAFT	2	Y4160
42	KEY; 1/8" X 1.00"	2	X225
43	SPACER	2	Y4150
44	12 DP WORM	2	X220
45	BEARING SKF6202-2RS SEAL BOTH SIDES	2	VM4250
46	WASHER .97 OD X .595 ID X .048 THICK	2	VW97X595-048
50	E-CLIP 5/8" EXTERNAL X .042	2	VR4295
51	SNAP RING	2	VR4220
52	COVER PLATE	2	Y4164
53	KNOB - SOFT TOUCH	2	A1512
54	WASHER .812"OD .406"ID .065"THICK	2	VW812X406-65
55	HANDWHEEL	2	X281
56	CRANK BUSHING	2	A1513
57	3/8-16 X 1-1/2 BUTTON HEAD CAP SCREW	2	VT37-16BH1.5
60	HANDWHEEL LABEL; DOWN <-> UP	1	Y4175
61	HANDWHEEL LABEL; RIGHT <-> LEFT	1	Y4170
62	NAME LABEL: MONSOON (MANUAL MODEL)	1	Y4182

9.2 MONSOON RC DRAWING & PARTS LIST

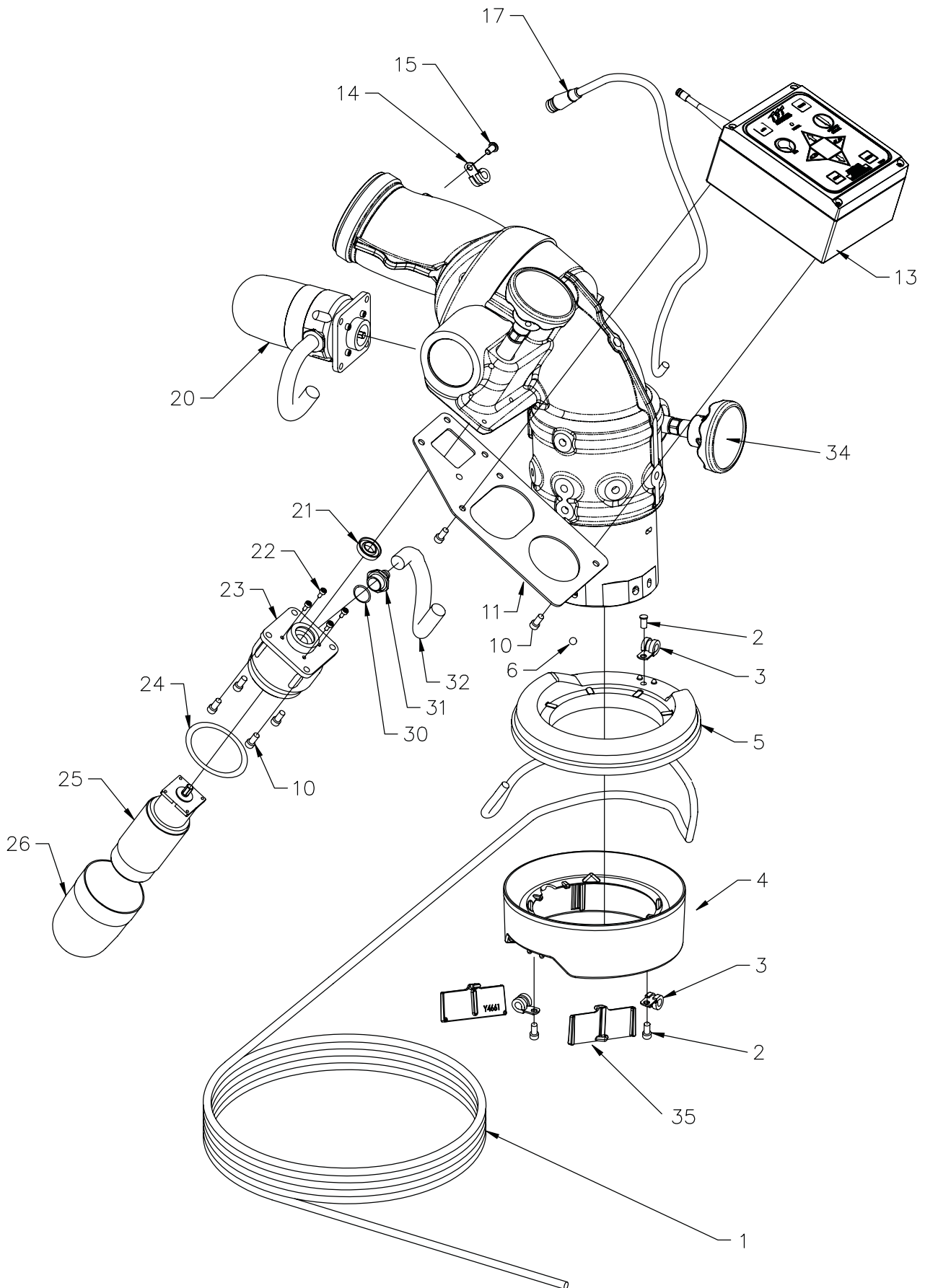

Fig 9.2
Monsoon RC Exploded View of Electrical Parts

MONSOON RC PARTS LIST

#	DESCRIPTION	QTY	PART #
1	CABLE-POWER & COM 2C#14	30 FEET	Y520
2	1/4-20 X 1/2 BUTTON HEAD CAP SCREW	3	VT25-20BH500
3	.375 OD LOOP CLAMP STAINLESS	3	Y4655
4	LOWER WIRE SKIRT	1	Y4660
5	UPPER WIRE SKIR	1	Y4650
6	BALL 5/16" STAINLESS	1	VB.312
10	1/4-28 X 1/2 SOCKET HEAD CAP SCREW	8	VT25-28SH500
11	CONTROL BOX BRACKET	1	Y4618
11*	CONTROL BOX BRACKET FOR LADDER & PLATFORM	1	Y4619
13	MAIN MONITOR CONTROL BOX	1	Y5800
14	.250 OD LOOP CLAMP STAINLESS	2	Y4656
15	10-24 X 3/8 BUTTON HEAD CAP SCREW	1	VT10-24BH375
17	CABLE - 2 POLE FEMALE PLUG	1	Y5280
20	GEAR MOTOR SUBASSEMBLY (#20 Contains Items #21 Thru #32, Except #27))	1	Y4950
21	CUP SEAL 1.0625 X .5625 X 1/4	1	Y4620
22	6-32 X 5/16 LONG SHCS WITH HEAD SEAL	4	VT06S32SH312
23	MOTOR SOCKET	1	Y4615
24	O-RING-038 2-5/8 ID 1/16 C/S	1	VO-038
25	GEAR MOTOR WITH ENCODER	1	Y4610
26	ENCLOSURE	1	Y4616
27	1/4-28X3/4 SOCKET HEAD CAP SCREW	4	VT25-28SH750
30	O-RING-018 3/4 ID 1/16 C/S	1	VO-018
31	CONDUIT FITTING	1	Y5213
32	HOSE - 3/8" ID PUSH-LOK	1 FOOT	Y5250
33	NAME LABEL: MONSOON RC	1	Y4180
34	OVERRIDE KNOB	2	Z245
35	WIRE SKIRT RETAINER	2	Y4661

9.3 MONITOR CONTROL BOX

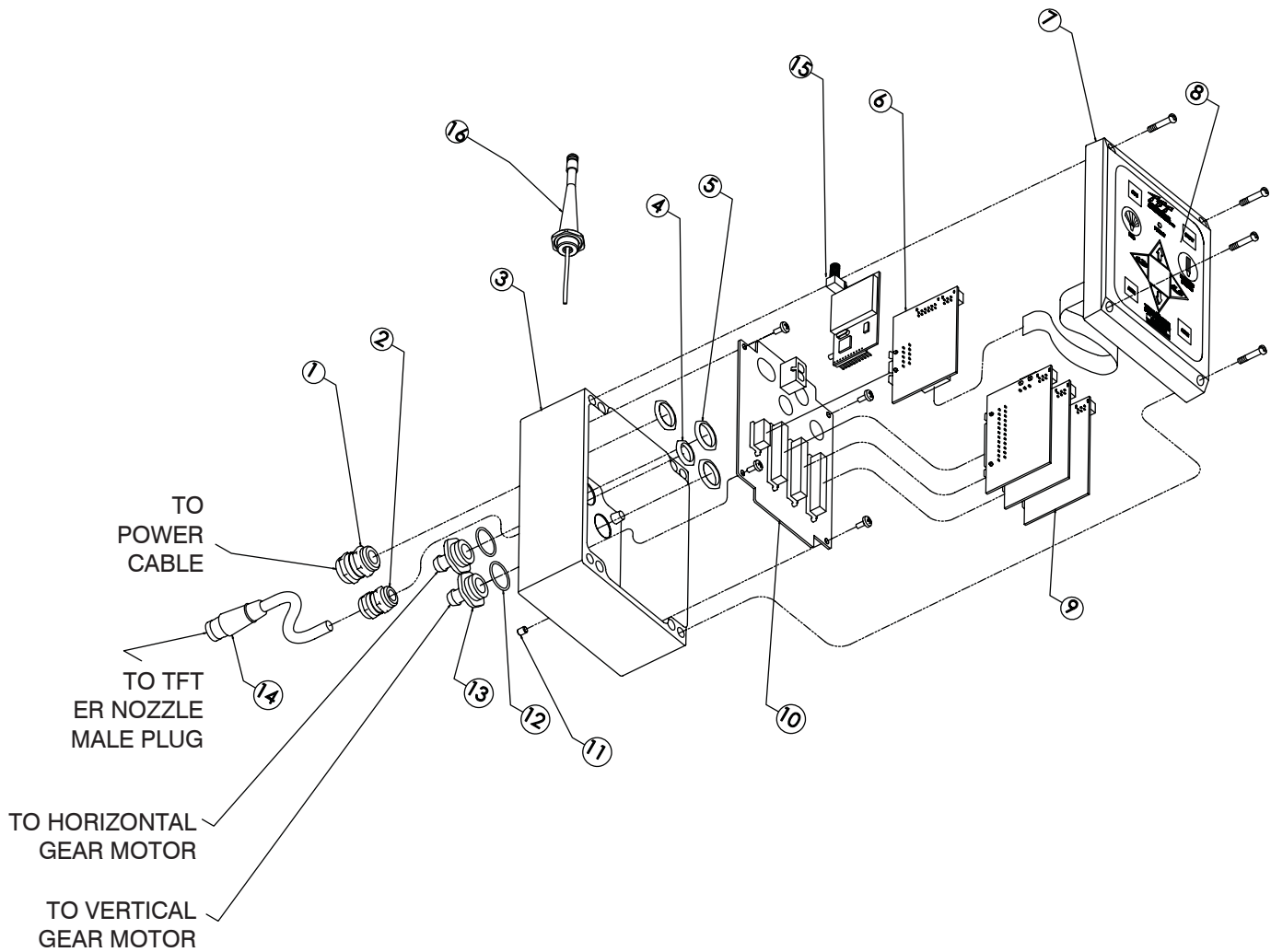

Fig 9.3 Monitor Control Box

MONSOON RC CONTROL BOX PARTS LIST

#	DESCRIPTION	QTY	PART #
1	CABLE FITTING PG11	1	Y5205
2	CABLE FITTING PG9	1	Y5245
3	ENCLOSURE - BOX	1	Y5115
4	LOCKNUT - PG9	1	Y5246
5	LOCKNUT - PG11	3	Y5206
6	BOARD - COMMUNICATION	1	Y5110-B
7	ENCLOSURE - LID	1	Y5115
8	CONTROL SWITCH PAD	1	Y5700
9	BOARD - MOTOR CONTROL	3	Y5100
10	BOARD - MAIN	1	Y5105
11	V10-32 x 1/4 SET SCREW	1	VT10Y32SS250
12	O-RING-018	2	VO-018
13	CONDUIT HOSE FITTING	2	Y5213
14	FEMALE PLUG - 6 POLE FOR TORNADO RC NOZZLE CONNECTION	10.0" TOTAL LENGTH USED 5.0" EXPOSED CABLE (not including plug)	Y5475
15	BOARD-OEM 900 MHZ RF MODULE (included with part YE-RF-900)	1	Y5710
16	ANTENNA W/FITTING	1	Y5881

10.0 WARRANTY

Task Force Tips, Inc., Valparaiso, Indiana 46383-6940 ("TFT") warrants to the original purchaser of its Monsoon and Monsoon RC Monitor ("equipment"), and to anyone to whom it is transferred, that the equipment shall be free from defects in material and workmanship during the five (5) year period from the date of purchase.

TFT's obligation under this warranty is specifically limited to replacing or repairing the equipment (or its parts) which are shown by TFT's examination to be in a defective condition attributable to TFT. To qualify for this limited warranty, the claimant must return the equipment to TFT, at 2800 East Evans Avenue, Valparaiso, Indiana 46383-6940, within a reasonable time after discovery of the defect. TFT will examine the equipment. If TFT determines that there is a defect attributable to it, it will correct the problem within a reasonable time. If the equipment is covered by this limited warranty, TFT will assume the expenses of repair.

If any defect attributable to TFT under this limited warranty cannot be reasonably cured by repair or replacement, TFT may elect to refund the purchase price of the equipment, less reasonable depreciation, in complete discharge of its obligations under this limited warranty. If TFT makes this election, claimant shall return the equipment to TFT free and clear of any liens and encumbrances.

This is a limited warranty. The original purchaser of the equipment, any person to whom it is transferred, and any person who is an intended or unintended beneficiary of the equipment, shall not be entitled to recover from TFT any consequential or incidental damages for injury to person and/or property resulting from any defective equipment manufactured or assembled by TFT. It is agreed and understood that the price stated for the equipment is in part consideration for limiting TFT's liability. Some states do not allow the exclusion or limitation of incidental or consequential damages, so the above may not apply to you.

TFT shall have no obligation under this limited warranty if the equipment is, or has been, misused or neglected (including failure to provide reasonable maintenance) or if there have been accidents to the equipment or if it has been repaired or altered by someone else.

THIS IS A LIMITED EXPRESS WARRANTY ONLY. TFT EXPRESSLY DISCLAIMS WITH RESPECT TO THE EQUIPMENT ALL IMPLIED WARRANTIES OF MERCHANTABILITY AND ALL IMPLIED WARRANTIES OF FITNESS FOR A PARTICULAR PURPOSE. THERE IS NO WARRANTY OF ANY NATURE MADE BY TFT BEYOND THAT STATED IN THE DOCUMENT.

This limited warranty gives you specific legal rights, and you may also have other rights which vary from state to state.