



**TASK FORCE TIPS**  
**FIRE FIGHTING EQUIPMENT**

# MONSOON MONITOR & MONSOON RC MONITOR

## INSTRUCTIONS FOR INSTALLATION, SAFE OPERATION AND MAINTENANCE

### **⚠ DANGER**

Read instruction manual before use. Operation of this device without understanding the manual and receiving proper training is a misuse of this equipment. A person who has not read and understood all operating and safety instructions, is not qualified to operate the Monsoon or Monsoon RC Monitor.

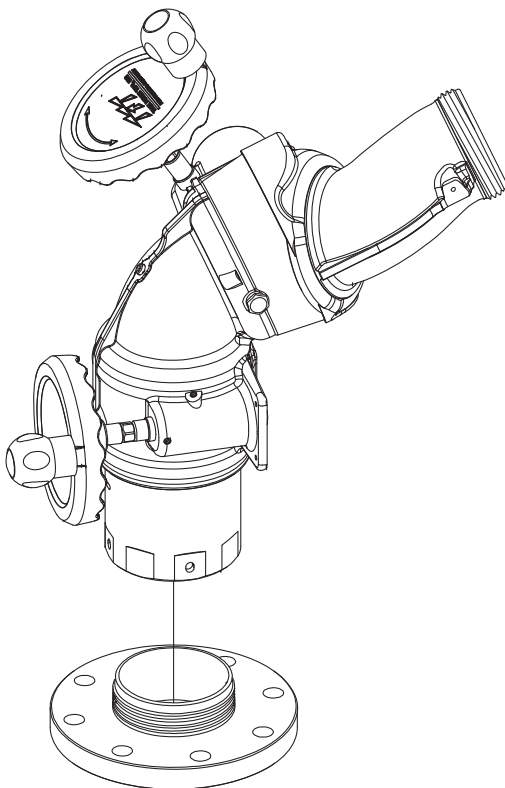

**MONSOON** 

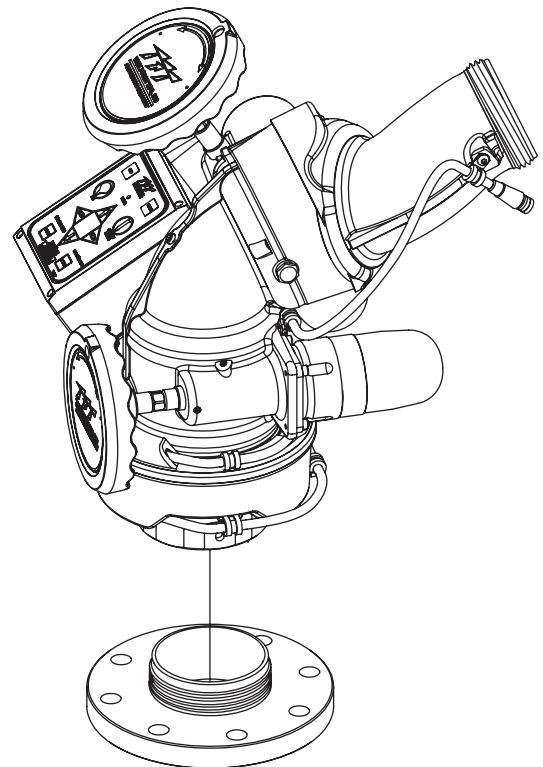

**MONSOON RC** 

Maximum Recommended Pressure is 200 psi (14 bar)

**TASK FORCE TIPS, Inc.**  
MADE IN USA • [www.tft.com](http://www.tft.com)

2800 E. Evans Ave., Valparaiso, IN 46383-6940 USA  
800-348-2686 • 219-462-6161 • Fax 219-464-7155

# **DANGER**

## **PERSONAL RESPONSIBILITY CODE**

The member companies of FEMSA that provide emergency response equipment and services want responders to know and understand the following:

1. Firefighting and Emergency Response are inherently dangerous activities requiring proper training in their hazards and the use of extreme caution at all times.
2. It is your responsibility to read and understand any user's instructions, including purpose and limitations, provided with any piece of equipment you may be called upon to use.
3. It is your responsibility to know that you have been properly trained in Firefighting and /or Emergency Response and in the use, precautions, and care of any equipment you may be called upon to use.
4. It is your responsibility to be in proper physical condition and to maintain the personal skill level required to operate any equipment you may be called upon to use.
5. It is your responsibility to know that your equipment is in operable condition and has been maintained in accordance with the manufacturer's instructions.
6. Failure to follow these guidelines may result in death, burns or other severe injury.



Fire and Emergency Manufacturers and Services Association, Inc.  
P.O. Box 147, Lynnfield, MA 01940 • [www.FEMSA.org](http://www.FEMSA.org)

# Table of Contents

<p><b>1.0 Meaning of Safety Signal Words</b> ..... 4</p> <p><b>2.0 Safety</b> ..... 4</p> <p><b>3.0 General Information</b> ..... 4-10</p> <p>    3.1 Mechanical and Electrical Specifications ..... 5</p> <p>    3.2 Part Identification and Models ..... 6</p> <p>    3.3 Inlets and Outlets ..... 7</p> <p>    3.4 Overall Dimensions ..... 8-9</p> <p>    3.5 Electrical Controls ..... 10</p> <p>        3.5.1 Motor Control Board (MCB) Auto Configure</p> <p>        3.5.2 Motor Current Limiting</p> <p>        3.5.3 Motor Soft Stops</p> <p>        3.5.4 Motor Slow/Fast Speed</p> <p>        3.5.5 Communication Protocol</p> <p>        3.5.6 Oscillate and Stow Features</p> <p>        3.5.7 Smart Stream Technology</p> <p><b>4.0 Installation</b> ..... 10-14</p> <p>    4.1 Structural Requirements for Monitor Mounting ..... 10</p> <p>    4.2 Inlet Fittings or Extend-A-Gun RC installation ..... 11-12</p> <p>    4.3 Nozzle Installation ..... 13</p> <p>    4.4 Horizontal Rotation Travel Stops ..... 13</p> <p>    4.5 Elevation Travel Stops ..... 14</p> <p>    4.6 Pressure Gage Port ..... 14</p> <p>    4.7 Drain ..... 14</p> <p><b>5.0 Electrical Controls Installation</b> ..... 15-28</p> <p>    5.1 Panel Monitor Operator Station ..... 17</p> <p>        5.1.1 Mounting</p> <p>        5.1.2 Electrical Wiring</p> <p>        5.1.3 Inputs Signal Configuration</p> <p>        5.1.4 Panel Mount Operation Station With STOW Relay</p> <p>    5.2 Tether Monitor Operator Stations ..... 19</p> <p>        5.2.1 Holster Mounting</p> <p>        5.2.2 Receptacle Mounting</p> <p>        5.2.3 Electrical Wiring</p> <p>    5.3 Wireless Monitor Operator Station ..... 20-21</p> <p>        5.3.1 MOUNTING STORAGE BRACKET</p> <p>        5.3.2 INSTALLING RADIO</p> <p>        5.3.3 TEACHING ID CODE</p> <p>        5.3.4 CHANGING BATTERIES</p> <p>    5.4 Joystick Monitor Operator Station ..... 21-22</p> <p>        5.4.1 Mounting</p> <p>        5.4.2 Electrical Wiring</p> <p>            5.4.2.1 Wiring to a Communication Interface Box</p> <p>    5.5 Toggle Switch Monitor Operator Station ..... 23</p> <p>        5.5.1 Enclosure Mounting</p> <p>        5.5.2 Electrical Wiring</p> <p>    5.6 Communication Interface Box ..... 23-24</p> <p>        5.6.1 Enclosure Mounting</p> <p>        5.6.2 Electrical Wiring</p> <p>        5.6.3 Inputs Signal Configuration</p> <p>        5.6.4 Communication Interface Box With At STOW Relay</p> <p>    5.7 Monitor Position Display ..... 25</p> <p>        5.7.1 Enclosure Mounting</p> <p>        5.7.2 Electrical Wiring</p> <p>    5.8 Remote Auxiliary Interface Box ..... 25-26</p> <p>        5.8.1 Enclosure Mounting</p> <p>        5.8.2 Electrical Wiring</p> <p>        5.8.3 Configuration</p>	<p>5.9 Connecting Monitor Cable Directly to Protected Power .. 26     Supply</p> <p>5.10 Electrical RC Monitor Aerial Truck Installation ..... 26-29</p> <p>    5.10.1 Electronics Enclosure Mounting</p> <p>    5.10.2 Electrical Wiring</p> <p>        5.10.2.1 Ladder Installation Electrical Wiring</p> <p>        5.10.2.1 Platform Installation Electrical Wiring</p> <p>    5.10.3 Electrical Enclosure With At STOW Relay</p> <p>        5.10.3.1 Electric Connections</p> <p>5.12 Electric Nozzle Actuator Wiring ..... 29</p> <p><b>6.0 Operation</b> ..... 29-36</p> <p>    6.1 Manual Model ..... 29</p> <p>        6.1.1 Horizontal Rotation Control</p> <p>        6.1.2 Elevation Control</p> <p>        6.1.3 Tiller Bar Manual Control</p> <p>    6.2 Electrical Model ..... 32-33</p> <p>        6.2.1 Electrical Operator Stations</p> <p>            6.2.1.1 Monitor Mounted Operator Station</p> <p>            6.2.1.2 Panel Mount Operator Station</p> <p>            6.2.1.3 Tethered Operator Station</p> <p>            6.2.1.4 Wireless Operator Station</p> <p>            6.2.1.5 Joystick Operator Station</p> <p>            6.2.1.6 Toggle Switch Operation Station</p> <p>        6.2.2 Master Override Feature</p> <p>        6.2.3 Stow Feature</p> <p>            6.2.3.1 Programming</p> <p>            6.2.3.1 Stow Programming Example</p> <p>        6.2.4 Oscillate Feature</p> <p>            6.2.4.1 Programming</p> <p>        6.2.5 Operator Station Panels</p> <p>        6.2.6 Override Hand Wheels</p> <p>    6.3 Recommended Stowing Position ..... 33</p> <p>    6.4 Flows and Pressures ..... 33-36</p> <p>        6.4.1 Stacked Tips Flow and Reach</p> <p>        6.4.2 Master Stream 2000 Nozzle</p> <p>        6.4.3 Monsoon Monitor Friction Loss</p> <p>    6.5 Stream Straighteners ..... 36</p> <p>        6.5.1 Stream Straighteners with Stacked Tip Nozzles</p> <p>        6.5.2 Stream Straighteners with Fog Nozzles</p> <p><b>7.0 Trouble Shooting</b> ..... 37-38</p> <p><b>8.0 Maintenance and Inspection</b> ..... 38</p> <p>    8.1 Lubrication Chart</p> <p>    8.2 Performance Testing</p> <p><b>9.0 Drawings and Parts List</b> ..... 39-43</p> <p><b>10.0 Warranty</b> ..... Back Cover</p>
---	--

## 1.0 MEANING OF SIGNAL WORDS

A safety related message is identified by a safety alert symbol and a signal word to indicate the level of risk involved with a particular hazard. Per ANSI standard Z535.4-1998 the definitions of the three signal words are as follows:



**DANGER** indicates an imminently hazardous situation which, if not avoided, will result in death or serious injury.



**WARNING** indicates a potentially hazardous situation which, if not avoided, could result in death or serious injury.



**CAUTION** indicates a potentially hazardous situation which, if not avoided, may result in minor or moderate injury.

## 2.0 SAFETY

The operation of this monitor can be dangerous. The following must be observed at all times.



**WARNING** Injury can result from an inadequately supported monitor. The monitor mount must be capable of supporting 1500 lbs (700 kg) of nozzle reaction force.



**WARNING** The stream exiting a monitor is very powerful and capable of causing injury and property damage. Make sure the monitor is securely attached to the base and pointing in a safe direction before water to the monitor is turned on. Use care in directing the stream.



**CAUTION** The electric Monsoon RC may be remotely operated. The electric drives are current limited but may still produce enough force to cause injury. Keep hands and fingers away from pinch points on the monitor.



**CAUTION** Do not use the manual override handwheels while the electric controls are in operation. The electric drives produce enough torque to cause injury.



**CAUTION** Maximum flow and pressure is 2000 GPM (7600 LPM) and 200 PSI (14 BAR). Damage or injury may result if the monitor is operated beyond these limits.

On many vehicle installations the monitor is the highest point on the apparatus. Often it is critical that the monitor be properly stowed before driving to avoid damage to overhead obstructions such as door openings. In these cases the use of a switch wired into the apparatus "door open" circuit is highly recommended. The switch should be wired to give a "door open" signal if the monitor is not in the stowed position. Due to the variety of possible mountings and nozzles, it is the installer's responsibility to supply the appropriate switch with mounting and wire it into their system. Always check stowed position of the monitor before moving the apparatus.

## 3.0 GENERAL INFORMATION

The Monsoon Monitor is a manually operated monitor designed for flows up to 2000 gpm (7,600 l/min). Maximum operating pressure is 200 psi (14 bar). Unique patent pending segmented waterway has only 15 psi (1 bar) friction loss at 2000 gpm. Water makes very few turns as it travels through the monitor resulting in low friction loss and a far reaching effective stream. Elevation range is 90 degrees above horizontal to 45 degrees below. Field changeable elevation travel stops at 45 degrees above, 30 degrees above, and 30 degrees below horizontal. The manual model has 360 degree continuous horizontal rotation with field changeable stops at 45, 90, and 135 degrees either side of a center position. Available with various inlet flanges and threaded fittings. Inlet also made for direct connection to TFT's electric Extend-A-Gun RC3 or RC4. Main waterway made from hardcoat anodized ANSI 356.0-T6 aluminum. Silver powder coat finish inside and out. Standard outlet is 3.5" NH (90 mm) rigid male thread.

The Monsoon RC is an electric remote controlled monitor that has all the benefits of the Monsoon monitor with the addition of powered operation. Designed for field changeable 12 VDC or 24 VDC operation. The Monsoon RC comes with a factory installed control panel mounted on the monitor for controlling horizontal rotation, elevation, and nozzle pattern. The motor control circuits are factory installed on the monitor and use position encoders and current limiting to protect the drive train at the ends of travel. Unit comes with ultra-flexing robotics cable already wired to the monitor so installation effort is minimized. Power wire has only four conductors (two for power and two for communications) further easing installation effort. Power wire is enclosed in a unique wire guide that allows 450 degrees of horizontal travel (225 degrees either side of a center position) which is far more reliable than slip rings or coil cords. Large handwheels for manual override are provided on the horizontal rotation and elevation drive. TFT's Master 2000 ER nozzle plugs into the factory installed nozzle power wire. Electric drives and control box are waterproof. Standard outlet is 3.5" NH (90 mm) rigid male thread.

### 3.1 MECHANICAL AND ELECTRICAL SPECIFICATIONS

#### MECHANICAL SPECIFICATIONS

Weight	Manual	25 lbm	11.4 kg
	Electric	37 lbm	16.8 kg
Min. Flow Area	4" inlets	12.6 in2	81.1 cm2
	3" inlets	7.07 in2	45.6 cm2
Max Flow		2000 GPM	7,600 LPM
Max Operating Pressure		200 PSI	14 BAR
Materials Used		ANSI A356.0-T6 Aluminum, Stainless, Nylon	

#### ELECTRICAL SPECIFICATIONS

Nominal Operating voltage:	12 or 24 VDC (field changable)	
Motor current:	Nominal*	Limit
Elevation motor:	6 amps	15 amps
Horizontal rotation motor:	6 amps	10 amps
Nozzle motor:	1 amp	5 amps
	*with rated water pressure applied	
At rest current:	.25 amps	
Recommended fuse or circuit breaker size:	15 amps @ 12 volts, 7.5 amps @ 24 volts	
Operating temperature range:	-30F to +120F (-34C to +49C)	
Environmental Rating: All components designed to meet minimum rating of NEMA 4 (IP65).		

#### WIRELESS OPERATOR STATION (YE-RF-##)

	YE-RF-900, 900 MHz	YE-RF-2400, 2.4 GHz
Handheld Unit Batteries	Four (AA) Batteries, Lithium Recommended	
Transmitting Power	100mW	50mW
Operating Range	500 ft (152m)	
Operating Frequency	900 MHz (902-928 MHz)	2.4GHz (2.4000-2.4835 GHz)
Agency Approvals		
FCC. . . . .	OUR9XSTREAM . . . . .	OUR24XSTREAM
Industry Canada (IC). . . . .	4214A-9XSTREAM . . . . .	4214A-12.008
Europe. . . . .	N/A . . . . .	ETSI

### 3.2 PART IDENTIFICATION AND MODELS

The Monsoon Monitor comes in manual and electric remote controlled models. Manual models are available with either handwheel control on both axis or a tiller bar model that uses a tiller bar to control horizontal rotation. Electric remote control models are available in a standard model (suitable for on top of pumpers), a Ladder model and a Platform model. Compared to the standard model, the ladder or platform model uses smaller override knobs, has a smaller swing radius and has horizontal travel stops factory installed at 90° left and right (180° total). The various models of Monsoon monitors shown in figures 3.2A, 3.2B, 3.2C and 3.2D. The monitor mounted control station on the standard remote controlled model is shown in figure 3.2E.

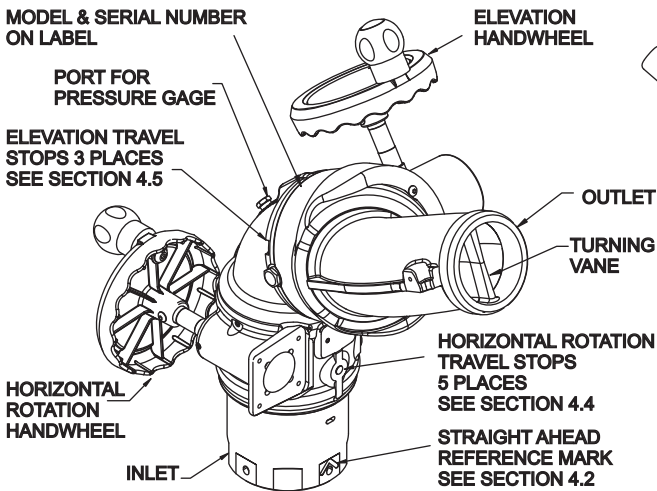

Fig 3.2A  
Manual Handwheel Monsoon Monitor

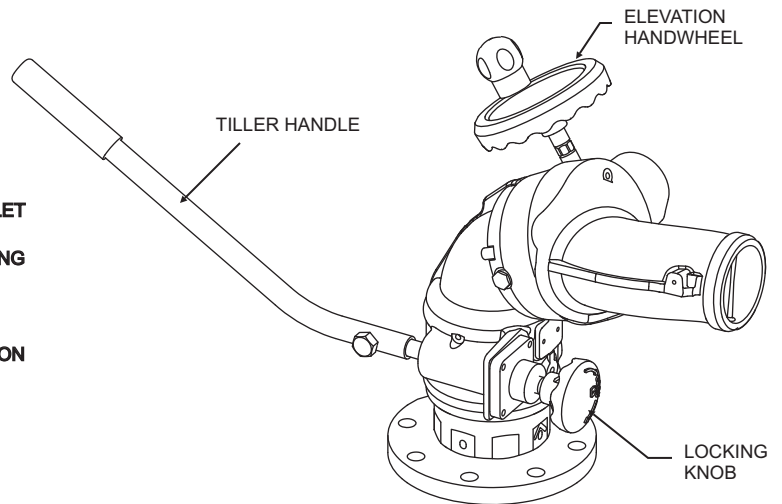

Fig 3.2B  
Manual Tiller Bar Monsoon Monitor

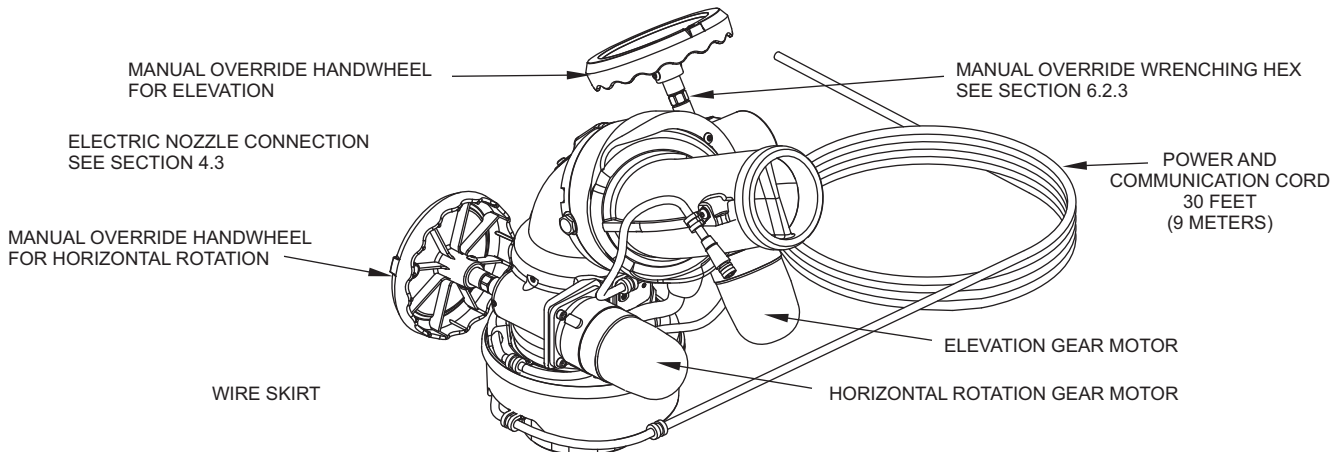

Fig 3.2C  
Electric Monsoon RC Monitor

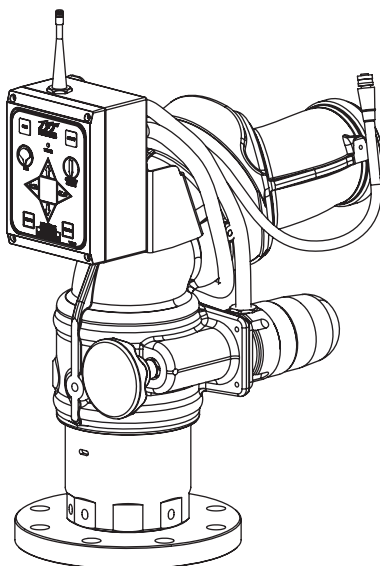

Fig 3.2D  
Electric Monsoon RC for Ladders or Platforms

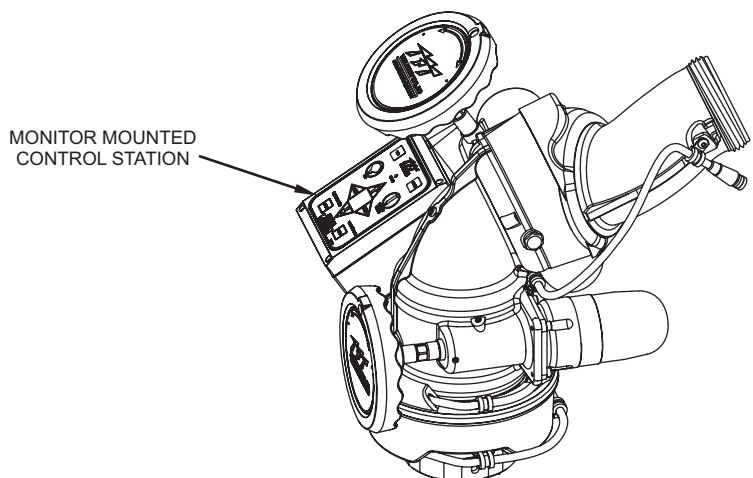
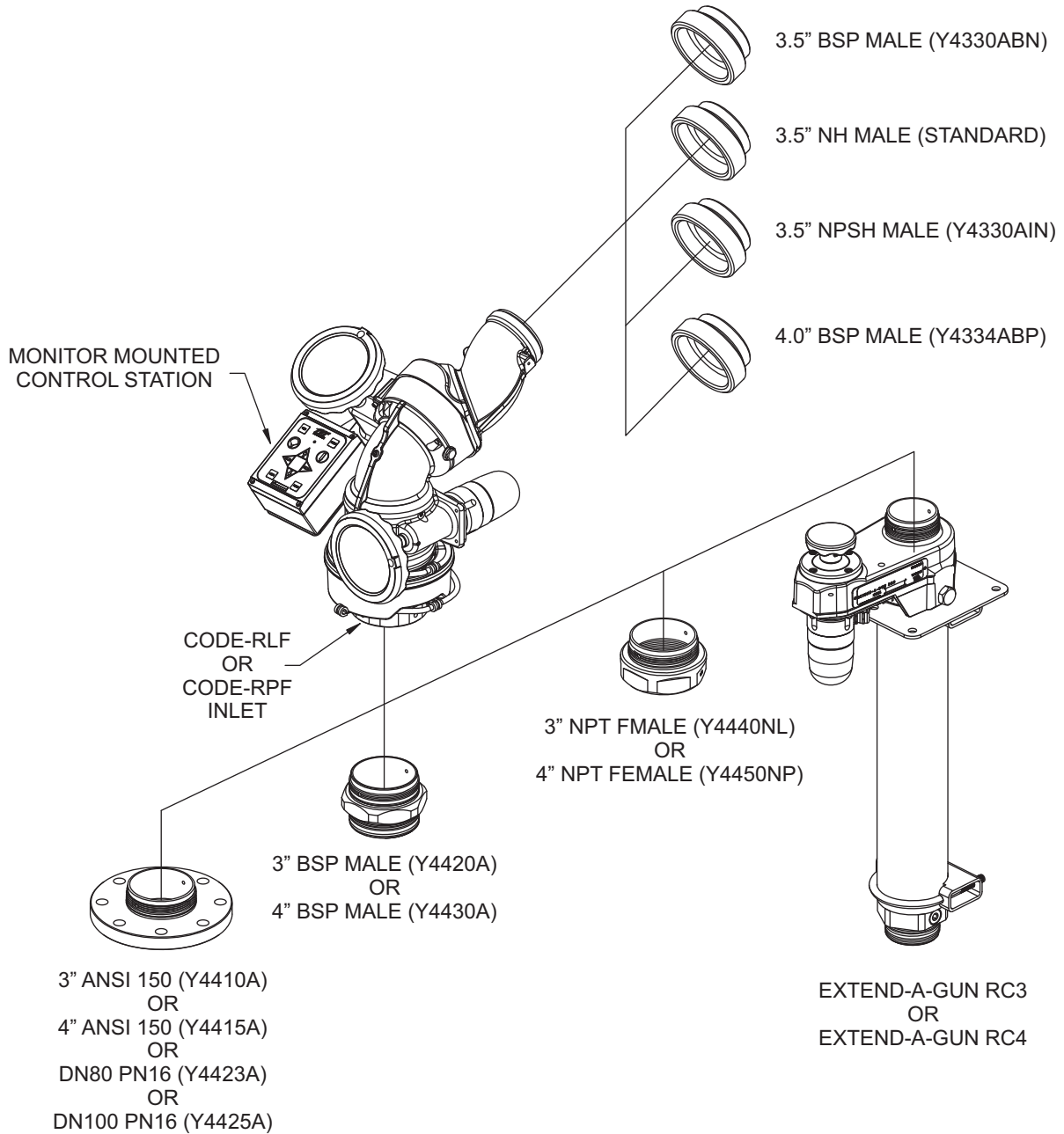

Fig 3.2E  
Electric Monsoon RC Standard Model

### 3.3 INLETS AND OUTLETS

The standard Monsoon Monitor inlet is CODE-RPF for direct connection to TFT's Extend-A-Gun RC4 (4 inch size). Monitor inlet CODE-RLF is available for direct connection to Extend-A-Gun RC3 (3 inch size). The standard outlet is 3.5"-6 National Hose male. Various other inlet and outlet adapters are available as shown in figure 3.3A.



FLANGE SIZE	OUTSIDE DIAMETER	THICKNESS	BOLT HOLE CIRCLE	NUMBER OF BOLTS	SIZE OF BOLTS	TORQUE ON BOLTS
3" ANSI 150	7.50"	.75"	6.00"	4	5/8"	76-80 FT-LBS
4" ANSI 150	9.00"	.94"	7.50"	8	5/8"	76-80 FT-LBS
DN80 PN16	200 mm	22 mm	160 mm	8	16 mm	100-110 NEWTON-METER
DN100 PN16	220 mm	22 mm	180 mm	8	16 mm	100-110 NEWTON-METER

Fig 3.3A  
Inlets and Outlets

### 3.4 OVERALL DIMENSIONS

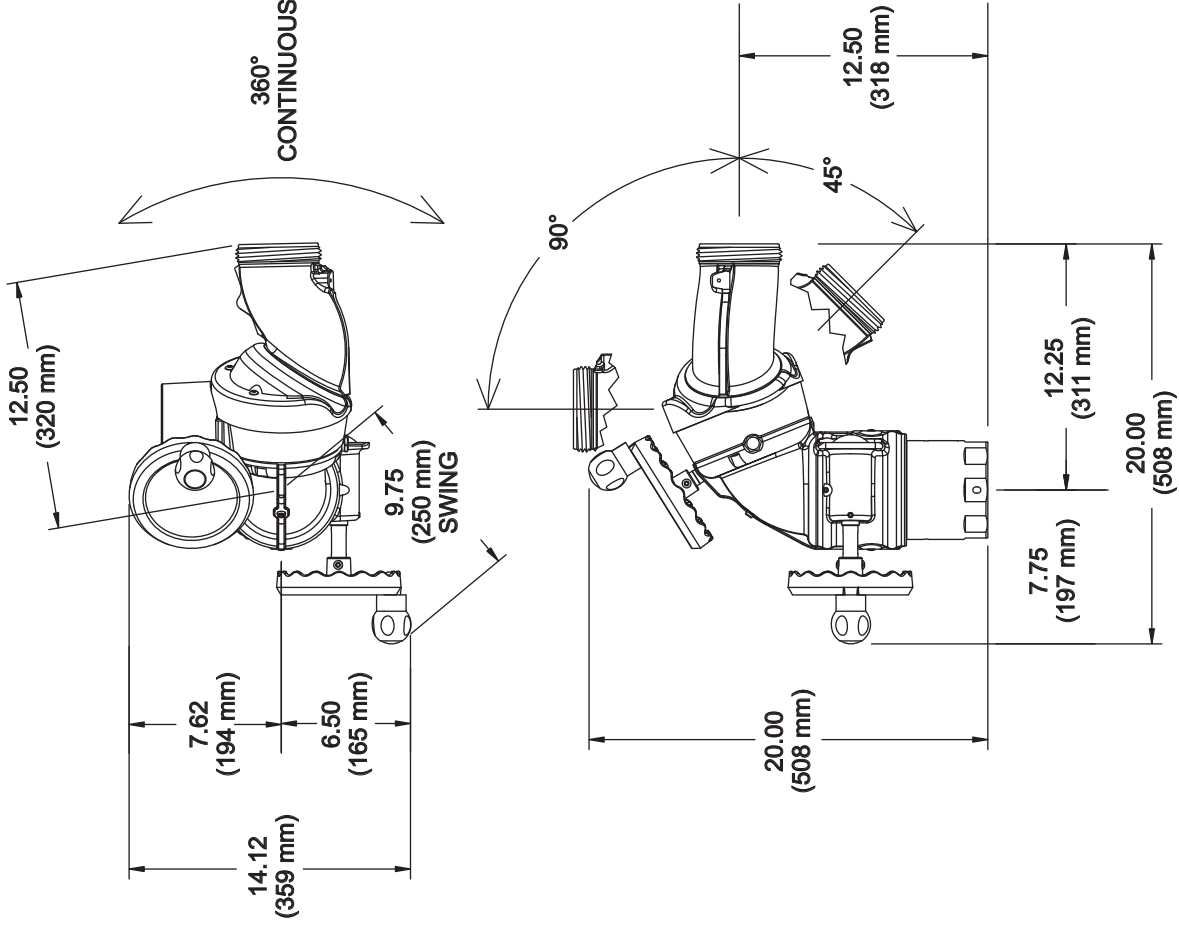

SHOWN WITHOUT INLET FITTING  
SEE FIG 4.2A FOR ADDITIONAL HEIGHT

**Manual Monsoon Dimensions**

Fig 3.4A

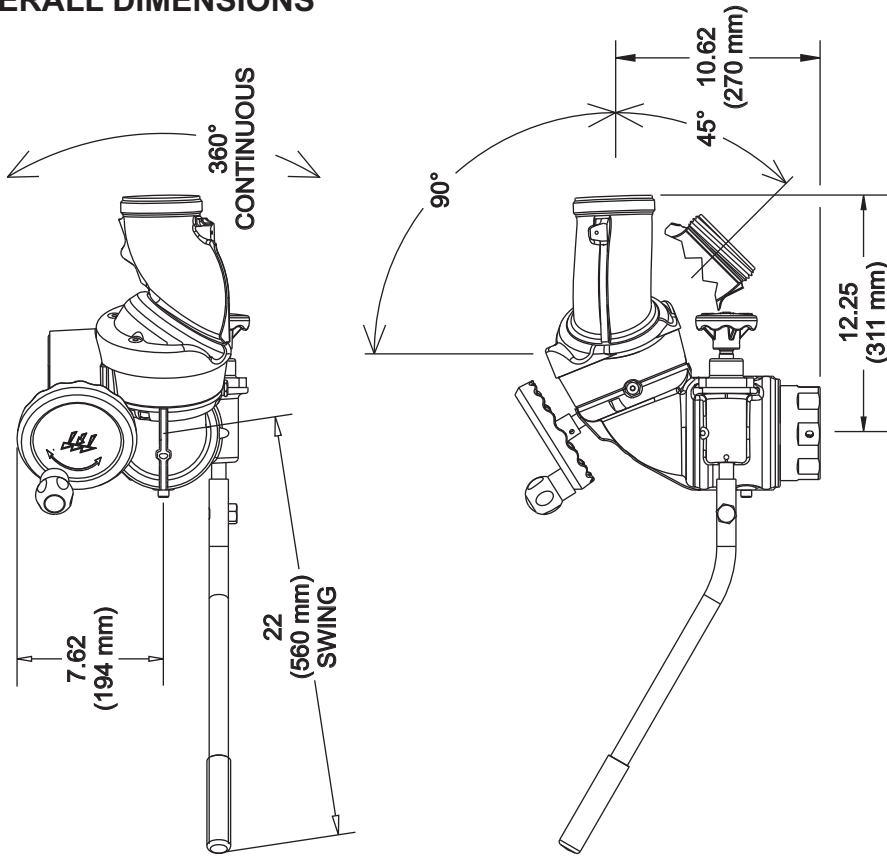

SHOWN WITH TILLER BAR  
AND WITHOUT INLET FITTING

**Manual Tiller Bar Monsoon Dimensions**

Fig 3.4B



### 3.4 OVERALL DIMENSIONS

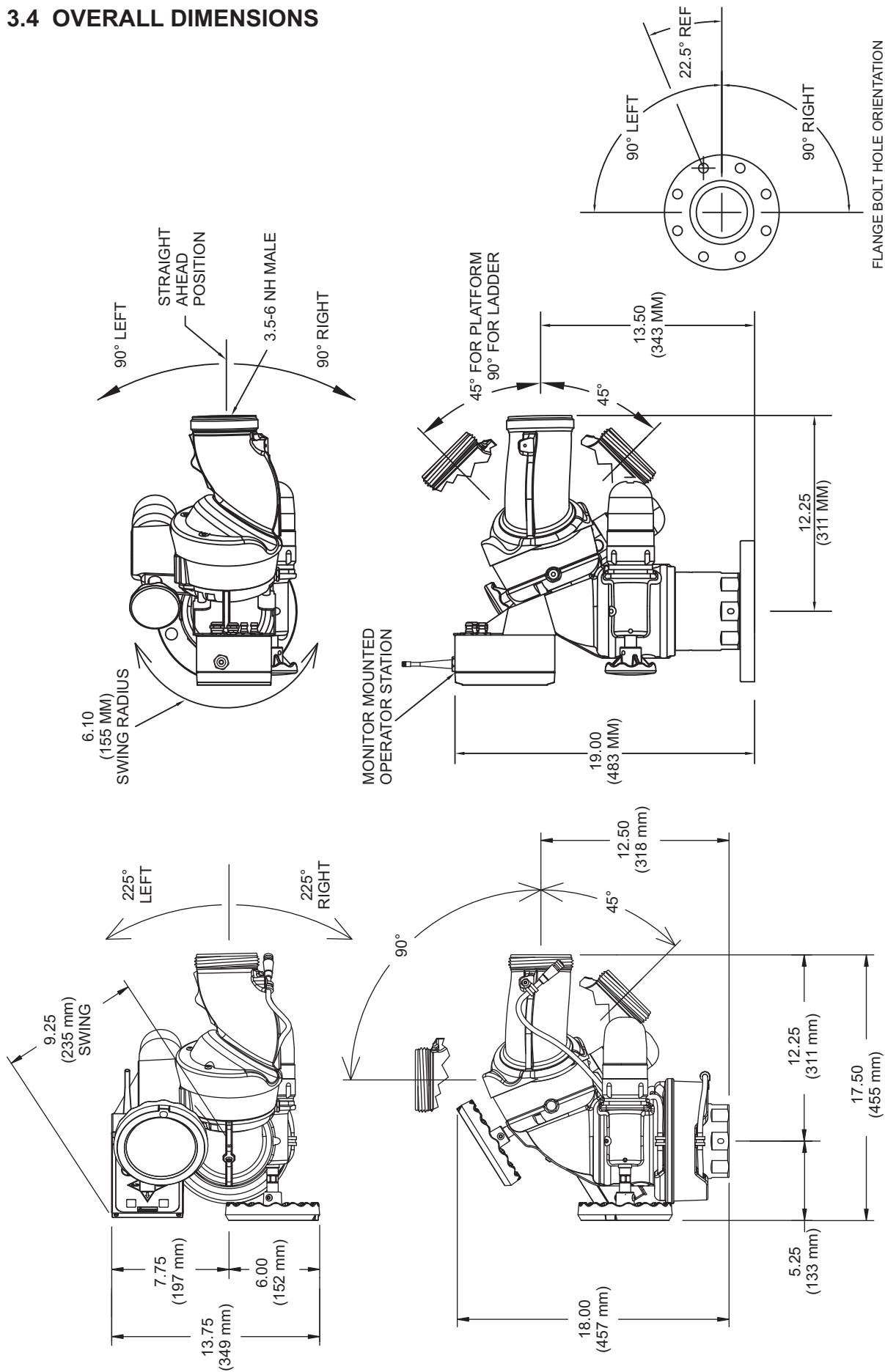

**Electric Monsoon RC  
For Ladders & Platform Dimensions**

Fig 3.4D

SHOWN WITHOUT INLET FITTING  
SEE FIG. 4.2A FOR ADDITIONAL HEIGHT

**Electric Monsoon RC Dimensions**

Fig 3.4B

## 3.5 ELECTRICAL CONTROLS

The electric Monsoon RC monitor is controlled by a powerful, state-of-the-art electronics system. The key components of the system are the motor control boards and a communication board. Each motor control board has its own microprocessor and a sophisticated motor control chip. The communication board also has a microprocessor, which handles the interface to the operator stations. All the components on these boards are solid state; there are no relays or electro-mechanical devices to wear out over time. The hardware and software have been designed with several key features and are outlined in the following sections.

### 3.5.1 MOTOR CONTROL BOARD (MCB) AUTO CONFIGURE

Each monitor has three MCBs, one for each motor, which controls motor movement and direction for horizontal rotation, elevation, and nozzle pattern. In the unlikely event of a MCB failure, the failed board can be removed and one of the other two remaining MCBs can be moved into that position. This MCB will then auto configure itself to take over the control of that axis, so that the monitor can continue to be used, with two of the three motors. This is also a helpful benefit when troubleshooting and requires fewer spare parts to be stocked.

### 3.5.2 MOTOR CURRENT LIMITING

The microprocessor on the MCB continuously monitors the motor current. As the motor reaches an end stop or if it hits an obstruction, the motor current rises very quickly and the motor control chip automatically shuts down the motor in a few milliseconds. This eliminates the need for any type of external limit switches and the associated wiring. The microprocessor also locks the operator from moving in the stopped direction again, until the operator first moves in the opposite direction.

### 3.5.3 MOTOR SOFT STOPS

The horizontal and vertical motors are equipped with feedback encoders, which allow the microprocessor to know the motor position at all times. The first time a motor reaches an end stop or strikes an obstruction, the microprocessor sets a new soft stop position just before the end stop. From that point on when the axis approaches the stop, the MCB automatically slows down the motor until the end stop is reached. This significantly reduces the wear on the motor, gearbox and gear drives.

### 3.5.4 MOTOR SLOW/FAST SPEED

When an operator presses one of the buttons, the associated motor starts in slow speed mode for accurate control of the water stream. After approximately 2 seconds the motor automatically ramps up to a fast speed, for quickly moving into position. When quickly changing directions, monitor retains speed from prior move. If low speed is selected, monitor does not ramp to high speed but remains in slow speed.

### 3.5.5 COMMUNICATION PROTOCOL

The communication from the monitor to the operator stations is performed over two wires using RS-485 serial protocol. Multiple operator stations can be added with only two wires for the RS-485 protocol between each station.

### 3.5.6 OSCILLATE AND STOW FEATURES

The OSCILLATE feature allows the user to program up to 65 points of continuous movement of the horizontal and vertical axes. The OSCILLATE pattern can be programmed from any operator station that has the OSC button. See Operator Station Label or Fig 6.2.4.1 for instructions.

The STOW feature allows the user to move the monitor, with one touch of a button, to a safe position before moving the fire truck. The monitor will always move to two end stops to verify the correct position of user choice. During the programming procedure the user has the ability to select which axis moves first. This is helpful to avoid lights, hoses, obstructions, etc. The user can program up to 10 points of movement to reach the final STOW position. The STOW pattern can be programmed from any operator station that has the STOW button. See section 6.2.3 and 6.2.4 for programming instructions.

### 3.5.7 SMART STREAM TECHNOLOGY

This technology, only available with TFT RC nozzles, utilizes a position encoder in the nozzle actuator to give the user greater control on the stream pattern, especially at FOG position. Nozzles equipped with a FLUSH position are programmed to stop and pause at full FOG position when moving towards the FLUSH position, preventing unwanted water flow. A second press on the button will cause the nozzle shaper to continue to move to FLUSH position for removing debris from the nozzle.

## 4.0 INSTALLATION

### 4.1 STRUCTURAL REQUIREMENTS FOR MONITOR MOUNTING

The structure that the Monsoon Monitor is mounted to must withstand the internal pressure of the monitor as well as shear and bending forces due to nozzle reaction. Nozzle reaction can be as high as 1,500 lbs (700 kg) (2000 gpm at 200 psi).

For flanged connections the use of flat flanges without raised faces is recommended. Use a full-face gasket as defined in SME 16.21 or ISO 7483. Tighten flange bolts in an alternating sequence as shown in figure 4A. Tighten to 76-80 ft-lb (100-110 Newton-Meters).

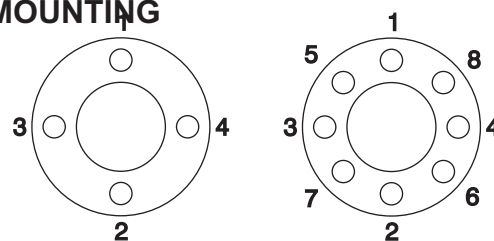

Tighten sequentially each bolt three times.

Fig 4.1A Flange Bolt Tightening Sequence



**Injury can result from an inadequately supported monitor. The monitor mount must be capable of supporting the nozzle reaction force which can be as high as 1500 lbs (700 kg). Flanges and pipe made from plastic are inadequate for monitor mounting and must not be used. This monitor is not recommended for portable use.**

## 4.2 INLET FITTING OR EXTEND-A-GUN RC INSTALLATION

The Monsoon Monitor is available with various inlet fittings as shown in fig 3.3A. When the inlet fittings are used see figure 4.2A for the addition to overall height. The Monsoon Monitor also connects directly to TFT's Extend-A-Gun RC3 or RC4. The fittings and Extend-A-Gun RC are attached to the monitor by means of a threaded joint with an o-ring seal. Once in the proper orientation the threaded joint is locked from rotation by two 1/4-28 button head cap screws as shown in figure 4.2B. This makes for easy removal of the monitor since the large threads of the joint are not tightened and do not have any thread locking compounds on them. It is best to install the inlet fitting or Extend-A-Gun RC to the apparatus and than install the monitor to the inlet fitting or Extend-A-Gun RC. This gives more room to install the bolts in the case of flanged fittings. Referring to figures 4.2B and 4.2C the installation sequence is as follows:

- 1) Install inlet fitting or Extend-A-Gun RC to apparatus.
  - Mount so that 180 degree apart threaded crossholes will give desired direction relative to the "Straight Ahead Reference Mark" when the monitor is installed. See figure 4.2B.
- 2) Screw monitor onto inlet fitting or Extend-A-Gun RC until threaded joint bottoms out.
  - Do not use pipe dope or Loctite on the inlet base threads. These threads are sealed with an o-ring. The use of thread locking compounds will make removal difficult.
- 3) Unscrew monitor slightly until a pair of 90 degree apart slots lines up with the 180 degree apart threaded crossholes in the inlet fitting or Extend-A-Gun RC.
  - Orient monitor so that the Straight Ahead Reference Mark is facing the desired direction.
  - Slots will line up with threaded crossholes every 90 degrees of rotation.
  - Monitor may be unscrewed up to one full turn from the bottomed out position.
- 4) Install 1/4-28 by 1/2 long button head cap screws and washers in the two threaded crossholes. Use Loctite #271 on the threads of the button head cap screws. **Allow Loctite to fully cure before applying water pressure.**

MODEL	INLET FITTING TYPE	ADDITIONAL HEIGHT
Y4-*1*A	3" ANSI 125/150 DN8, PN20	0.75" 20mm
Y4-*2*A	4" ANSI 150 DN100, PN20	0.94" 24mm
Y4-*4*A	DN80, PN16	0.75" 20mm
Y4-*5*A	DN100, PN16	0.94" 24mm
Y4-*6*A	3" NPT FEMALE	2.00" 51mm
Y4-*7*A	4" NPT FEMALE	1.75" 45mm
Y4-*8*A	3" BSP MALE	2.30" 58mm
Y4-*9*A	4" BSP MALE	2.30"

Fig 4.2A Additional Height for Inlet Fittings

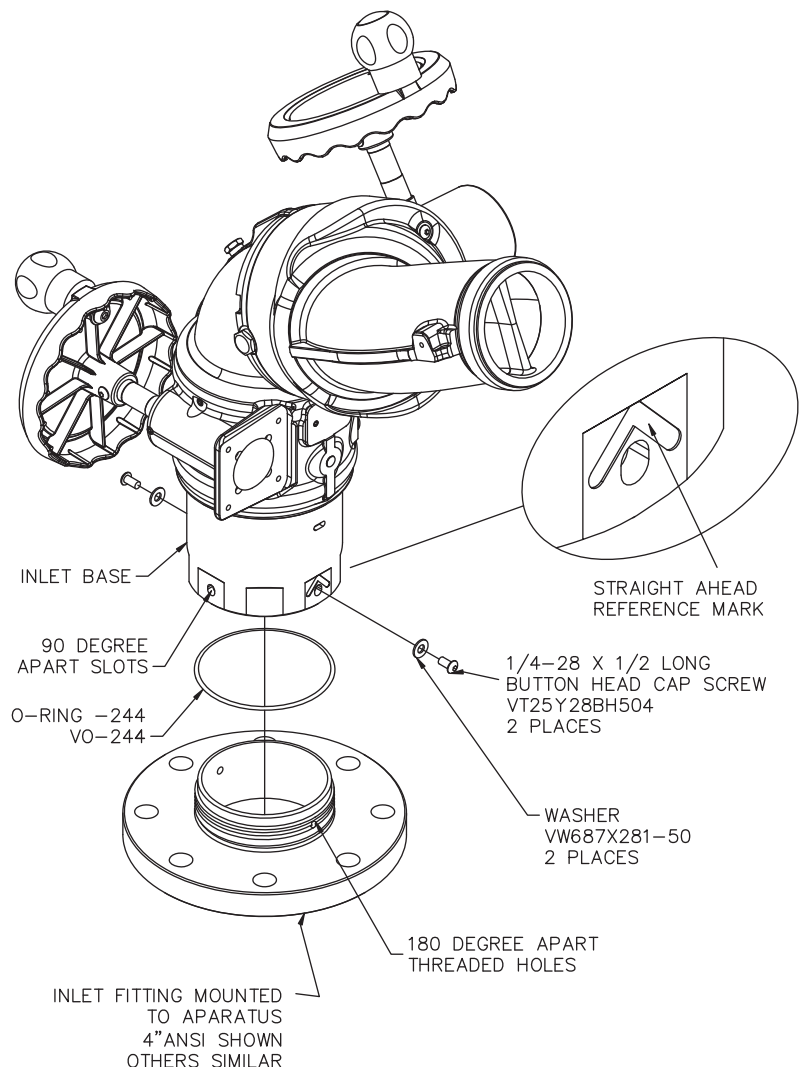

Fig 4.2B Inlet Fitting Connection

## 4.2 INLET FITTING OR EXTEND-A-GUN RC INSTALLATION

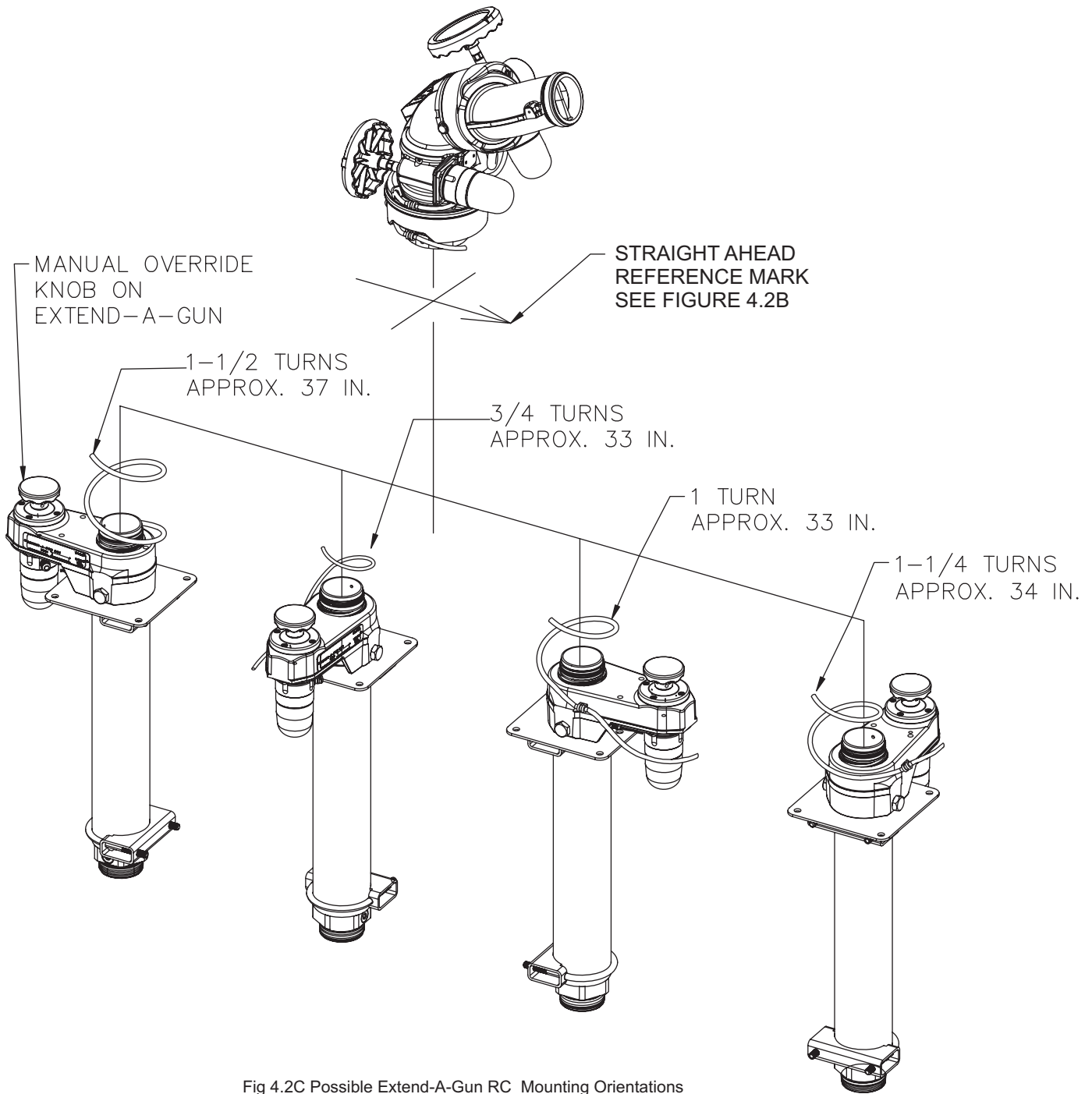

Fig 4.2C Possible Extend-A-Gun RC Mounting Orientations

The Extend-A-Gun manual override knob may be mounted in any of four possible orientations (90 degrees apart) relative to the Straight Ahead Reference Mark on the monitor.

**NOTE:** Monsoon monitor, for use with Extend-A-Gun RC, comes with the wire installed in a nylon tube. The nylon tubing gives the wire additional stiffness so it better follows as the Extend-A-Gun RC extends or retracts. A fitting is also supplied and is to be used where the nylon tubing and wire pass through the deck.

### 4.3 NOZZLE INSTALLATION

The nozzle is simply screwed onto the monitor's exit threads. If the nozzle is installed on a Monsoon RC (with electric motors) assure that the nozzle's coupling does not make contact with the horizontal drive motor housing when the monitor is in it's lowest elevation position.

For nozzles with electric pattern control, a cable with a female, waterproof connector is provided at the outlet of the Monsoon RC which attaches directly to TFT's electric Masterstream 1250, 1500 or 2000 nozzle. The cable used is a dual-key, micro type plug assembly. Any other nozzle should have the corresponding male electrical connector installed. The waterproof cap should be installed when using stacked tips. Do not cut off the female connector on the monitor. This connector is molded onto the cable and must remain in place to maintain the water tightness of the electrical system.



**The nozzle threads must match the threads of the Monsoon monitor in both size and type. Mismatched or damaged threads may cause the nozzle to leak or uncouple under pressure and could cause injury.**



**Do not connect aluminum to brass or brass to aluminum. Dissimilar metals coupled together can cause galvanic corrosion that will freeze the threaded joint or cause complete loss of thread engagement. If dissimilar metals must be coupled together, the effects of corrosion can be greatly delayed by various coatings on the metal such as powder paint, hard anodizing, or silicone grease.**

### 4.4 HORIZONTAL ROTATION TRAVEL STOPS

The range of horizontal rotation travel for the manual Monsoon monitor is continuous 360 degrees. The motorized version is limited to 450 degrees total horizontal rotation travel or 225 degrees from either side of a straight ahead position. Horizontal rotation travel stop bolts may be installed in the monitor to limit travel as shown in figures 4.4A and 4.4B. Note that left and right are relative to the "Straight Ahead Reference Mark" (the Straight Ahead Reference Mark is shown in figures 4.2B and 4.4D) and refer to the nozzle's discharge direction as seen from an operator's position behind the nozzle. Figures 4.4A and 4.4B show the range of travel for the various stop bolt locations and give installation notes.

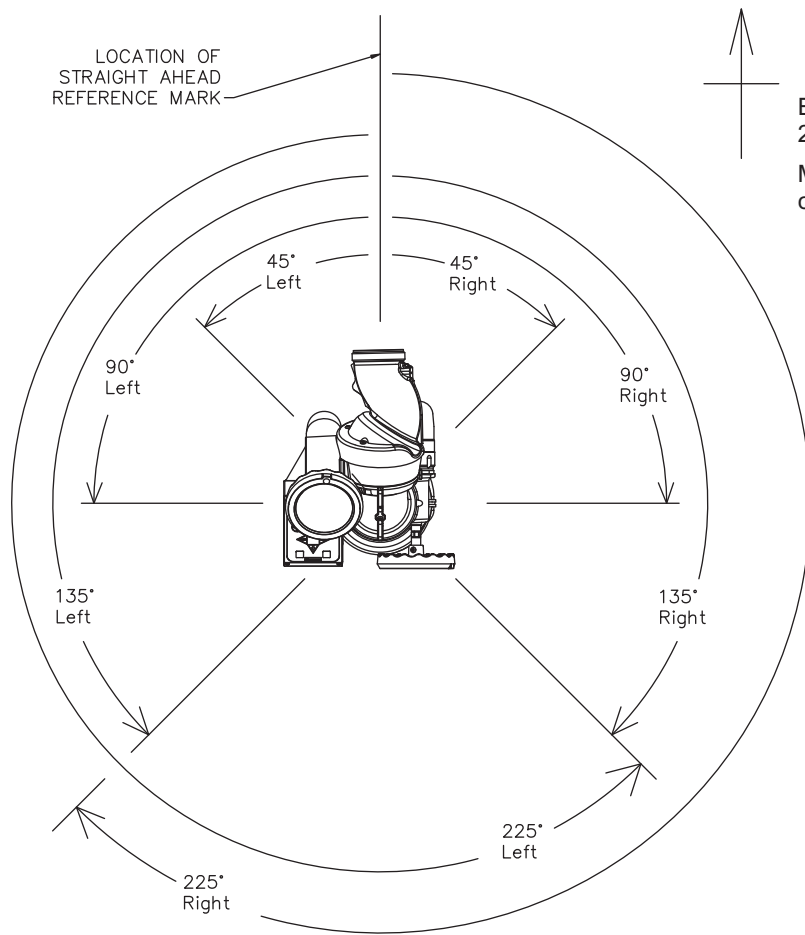
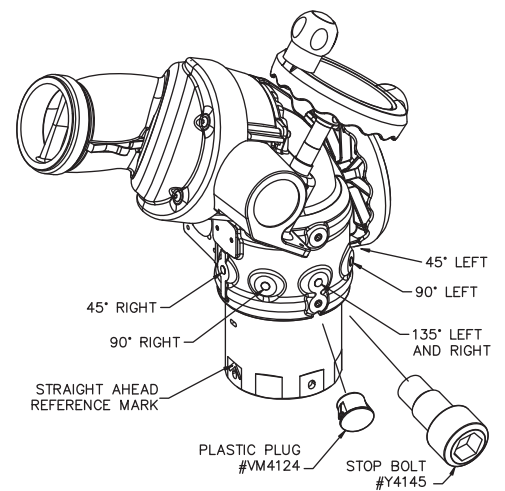

Fig 4.4A  
Horizontal Rotation Travel Limits

Electric model with no stop bolts installed has 225° left and right horizontal rotation travel limits.

Manual model with no stop bolts installed has continuous 360° horizontal rotation travel.



Pry out plastic plug and install Stop Bolt to obtain desired travel limits.

Fig 4.4B  
Horizontal Rotation Travel Stop Locations

## 4.5 ELEVATION TRAVEL STOPS

The range of elevation travel for the Monsoon Monitor is 90 degrees above zero to 45 degrees below zero. The elevation range may be limited by installing the supplied stop bolts at the locations shown in figures 4.5A and 4.5B. Consult factory for other ranges. The figures include installation notes.

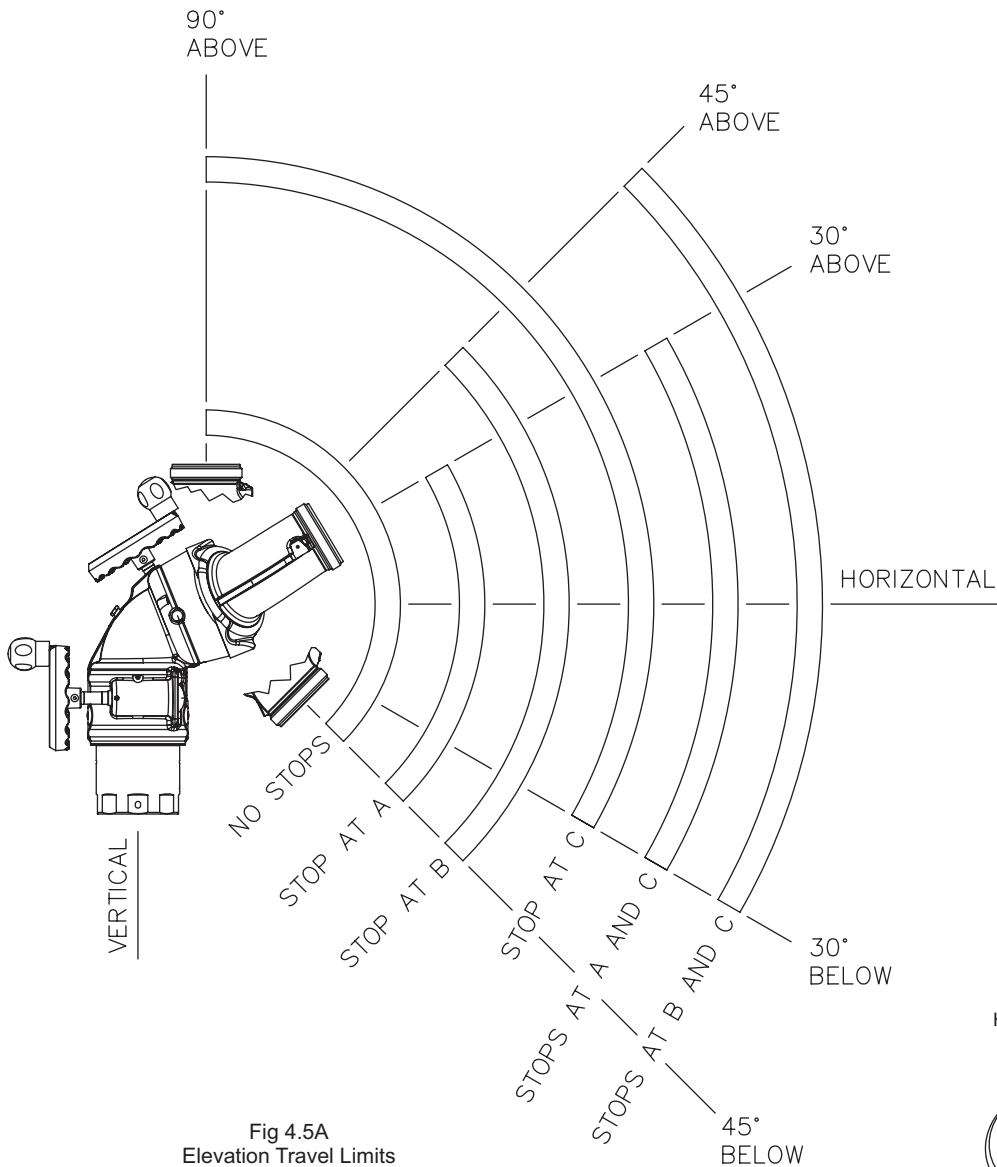

Fig 4.5A  
Elevation Travel Limits

Pry out plastic plug and install Stop Bolt to obtain desired travel limits.

Elevation travel with no Stop Bolts is 90° above and 45° below zero.

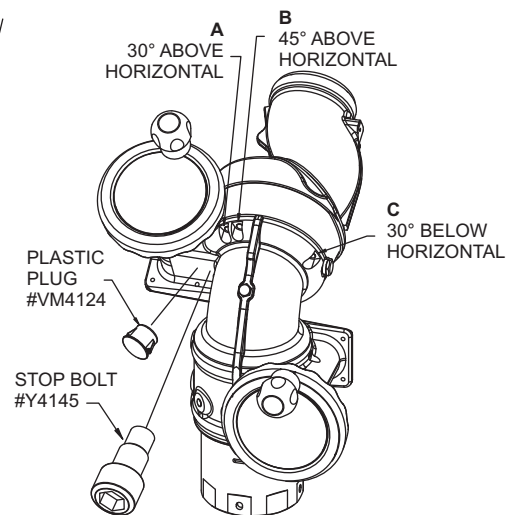

Fig 4.5B  
Elevation Travel Stop Locations

## 4.6 PRESSURE GAGE PORT

There is a 1/4" NPT female threaded hole on the back of the monitor. The hole is plugged from the factory. If a pressure gage is desired, unscrew the plug and install the gage using pipe sealant. Make sure the gage does not interfere with the elevation handwheel.

## 4.7 DRAIN

There is no drain on the Monsoon Monitor itself. A drain valve should be installed on the monitor's inlet piping.

## 5.0 ELECTRICAL CONTROLS INSTALLATION

The electric RC monitor is supplied with a monitor mounted operator station. The wiring on the monitor and for this operator station is factory installed. The assembly is supplied with a 30-foot length of cable for connection to the operator control stations as shown in Figure 5.0 or directly to a protected voltage supply. This cable has 4-conductors which supply power and the communications from the operator stations to the monitor. To complete the installation, the installer will need to mount and wire the selected operator stations. The power supply for the monitor will need to be connected to a protected circuit from the truck's power distribution center. Refer to the specifications section 3.2.1 for nominal current draw.

For installations where the customer would like to turn off the voltage to the monitor independent of the truck master switch, the installer needs to install a SPST (single-pole single-throw) toggle switch. Install this toggle switch in a location that can quickly be accessed before using the RC monitor. The toggle switch needs to be wired between the protected voltage supply and the red wire feeding the RC monitor.

- Good mechanical connections on the wires are absolutely necessary and should be checked periodically. Poor electrical connections can cause power loss to the electric RC monitor and be a fire hazard.
- Careful selection of wiring is critical to avoid excessive voltage drop.
- Be careful to route cables in a protected area away from high heat sources.
- Use grommets whenever wires pass through holes to prevent damage due to snags, abrasions, etc.
- Secure cables close to control box with plastic wire ties or cable clamps to relieve stress on the cables.
- Disconnect power before installing or servicing the electrical components. The RC monitor control boxes and motors are not rated as ignition proof, explosion proof, or intrinsically safe.



**The electric motors and other components are ignition sources. The electric drives should be operated only in areas where there is adequate ventilation and no hazard of flammable vapor buildup.**

### Recommended Tool List

- 11/32" nut driver
- Wire cutter/stripper
- Terminal crimping tool
- Utility knife
- 20mm open-end box wrench
- 17mm open-end box wrench
- 5/32" drill bit
- 25/32" drill bit
- #2 Phillips screwdriver
- Small flat blade screwdriver

## IMPORTANT

Review these sections and decide on locations before starting installation process.

### 6.2.1 OPERATOR STATIONS

#### 6.2.1.1 MONITOR MOUNTED OPERATOR STATION

#### 6.2.1.2 PANEL MOUNT OPERATOR STATION (Y4E-RP)

#### 6.2.1.3 TETHER OPERATOR STATION (Y4E-CT-##)

#### 6.2.1.4 WIRELESS OPERATOR STATION (YE-RF-##)

#### 6.2.1.5 JOYSTICK OPERATOR STATION (Y4E-JS)

#### 6.2.1.6 TOGGLE SWITCH OPERATOR STATION (Y4E-TS)

## IMPORTANT!!

When mechanical installation and electrical connections are complete, perform the following test to verify voltage supply is adequate and the current limiting feature is functioning.

- 1) Apply power to monitor control box.
- 2) Press LEFT or RIGHT button and hold until monitor reaches its stop position. Continue to hold button down.
- 3) Once movement is stopped, manually turn override knob in opposite direction while continuing to hold button down. If knob can be turned, then voltage supply is adequate. If knob cannot be turned and motor continues to operate, then the voltage supply or wiring is not adequate. Check connections and voltage connection point, rewire if necessary. **NOTE: Override knob will only turn in one direction.**

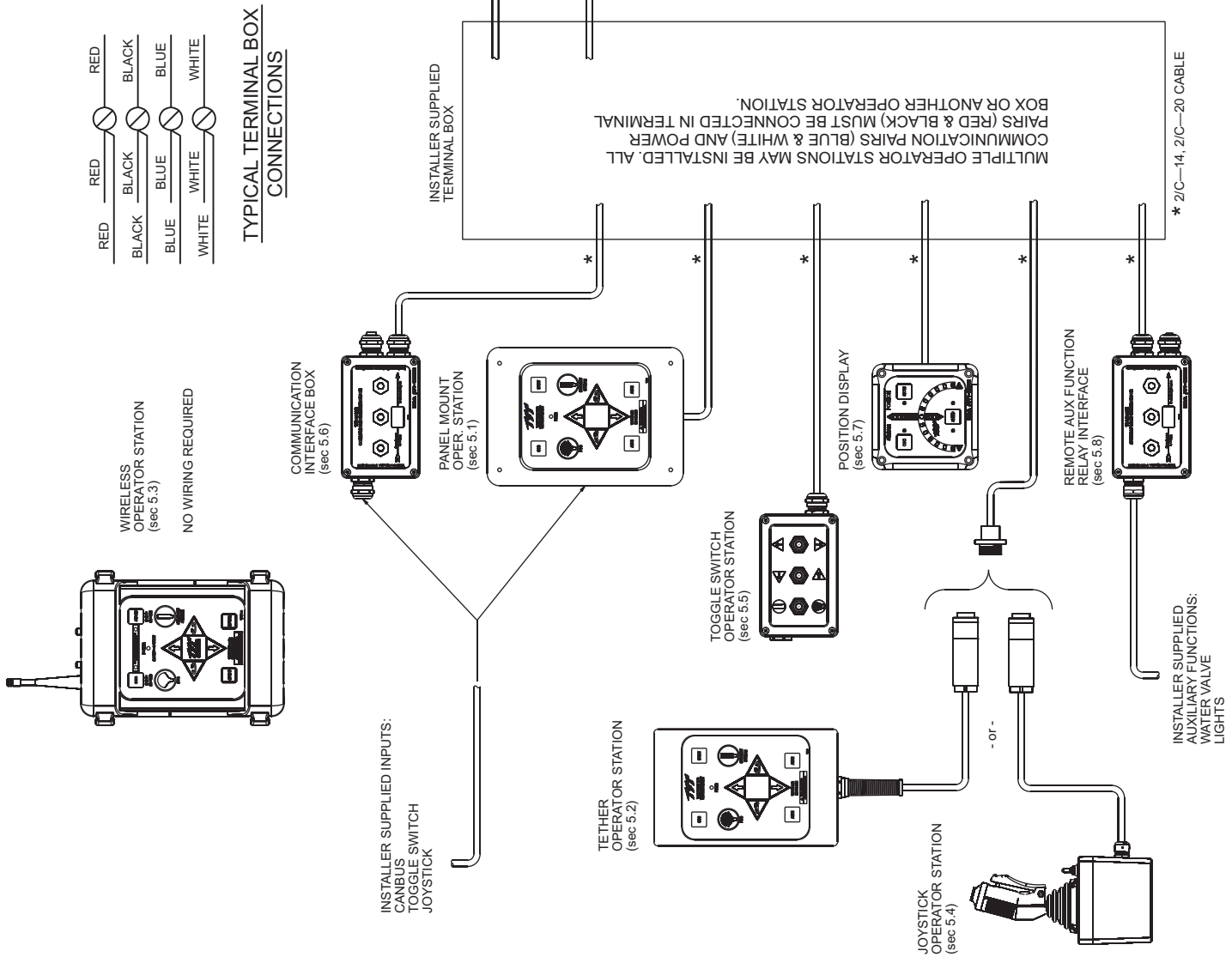

- TYPICAL TERMINAL BOX CONNECTIONS
- RED — RED
  - BLACK — BLACK
  - BLUE — BLUE
  - WHITE — WHITE

**\*\*Note**  
To avoid excessive voltage drop at monitor operator station, do not lengthen factory supplied monitor cable. Power cable selection is critical. Voltage supplied to TERMINAL BOX should not fall below 13 volts when monitor is in operation.

Recommended Cable Gauge	Max Length*	Gauge
	40 ft (12m)	14AWG
	65 ft (20m)	12AWG
	80 ft (24m)	2-14AWG
	105 ft (32m)	10AWG
	130 ft (40m)	2-12AWG

\*Based on 12 volt nominal truck power

Fig 5.0 Electrical Components (non-aerial installation)



## 5.1 PANEL MONITOR OPERATOR STATION (Y4E-RP)

This operator station allows the monitor to be controlled from a remote location. The installer will need to mount the operator station and connect the cable to the monitor and power. The enclosure is designed to be recess mounted in a panel.

This operator station has extra power and communication terminal blocks available and can be used as a central location for terminating wires. In this type of installation the monitor cable, the power cable, and possibly other operator station cables could be installed into this operator station. On the back of this enclosure are extra strain relief fittings.

In many installations this operator station will also include the wiring connections for the joystick, Canbus output module or installer supplied toggle switches. A terminal block is available for "UP, DOWN, LEFT, RIGHT, FOG, SS, STOW" inputs. The circuit board in this operator station is factory configured to accept ground input signals but can be field changed to accept +12/24 volt DC input signals.

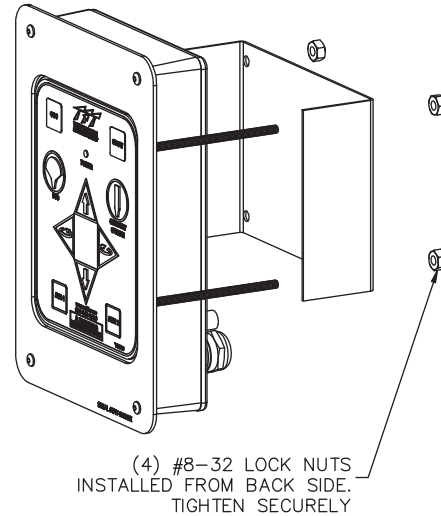
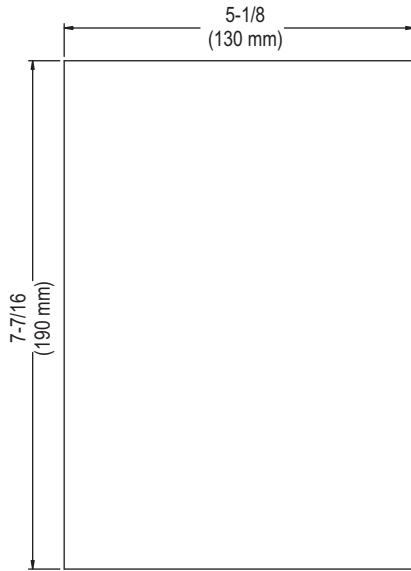

Fig 5.1.1  
Panel Mount Operator Station Cutout Dimensions

### 5.1.1 MOUNTING

Select proper operator location. Panel space required will be 5-5/8" x 8" (142 x 200mm). A depth of 3-1/2" (89mm) will be required behind the panel. Additional space will be required where the cables exit the back of the enclosure. Refer to Figure 5.1.1 for cutout dimensions.

### 5.1.2 ELECTRICAL WIRING

See figure 5.0 for typical connections. The 4-conductor cable from the operator station needs to be connected to power (red & black) and to the communication link (blue & white) from the monitor. Refer to Figure 5.1.2 for typical cable preparation. Be sure to tighten all terminal block screws securely.

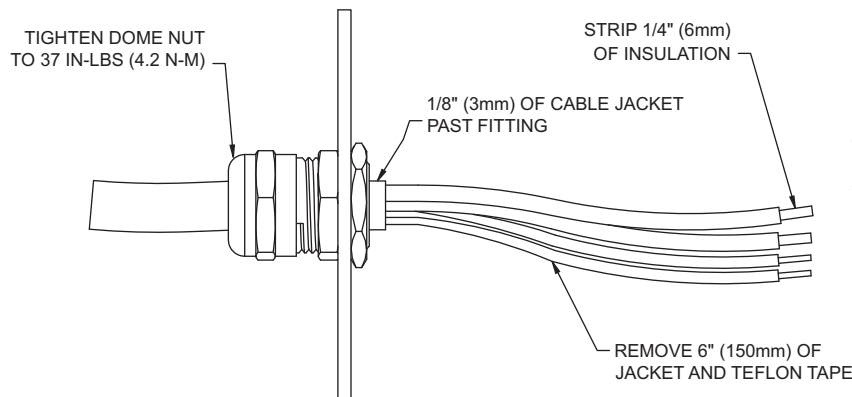

**NOTE:**  
CABLE IS GEL FILLED TO PREVENT MOISTURE WICKING  
INTO ENCLOSURE. GEL IS NON-HAZARDOUS AND  
SHOULD BE WIPED OFF CONDUCTORS WITH RAG.

Fig 5.1.2  
Typical Cable Preparation

### 5.1.3 INPUTS SIGNAL CONFIGURATION

The Panel Mount Operator Station is shipped from the factory configured to accept ground input signals, but can be field changed to accept +12/24 volt DC input signals. To change the configuration:

1. Remove lid from enclosure.
2. Locate DIP switches on communication board.
3. Slide DIP switch #4 to the OFF position to select GROUND inputs or slide to the ON position to select VOLTAGE inputs.
4. Replace lid. Verify rubber seal is clean and undamaged. Verify that no wires are caught between lid and box.

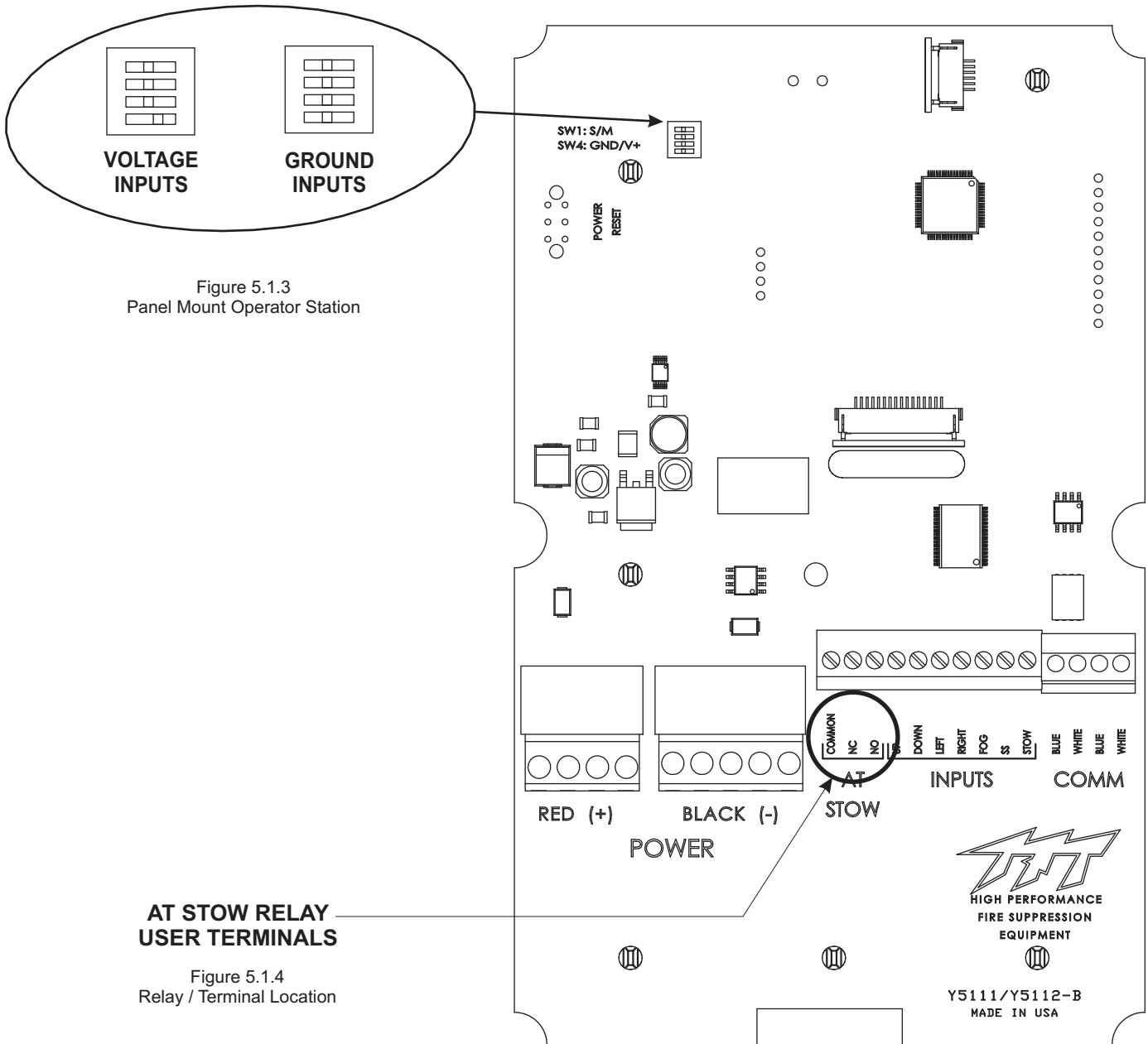

Figure 5.1.3  
Panel Mount Operator Station

AT STOW RELAY  
USER TERMINALS

Figure 5.1.4  
Relay / Terminal Location

### 5.1.4 PANEL MOUNT OPERATOR STATION WITH AT STOW RELAY (Y4E-RP)

The Panel Mount Operator Station provides feedback for the user that the monitor is in the AT STOWED position. The Operator station contains a circuit board that is equipped with a relay that is energized when the monitor is in use and de-energized when the monitor reaches its final STOW location. The contact rating of the relay is 1 amp @ 30VDC for resistive loads and 0.2 amps @ 30VDC for inductive loads.

The AT STOW relay has one Form-C contact (common, normally open, normally closed) that can be used. The figure above shows the terminal blocks available for user wiring.

## 5.2 TETHER MONITOR OPERATOR STATION (Y4E-CT-##)

This operator station will have a factory installed 4-conductor cable, which will act as a tether, with a plug on the end. The installer will need to mount the holster and receptacle.

The holster is supplied with (3) 1/4-20 stainless steel self-tapping screws. Make sure the material beneath the bracket is substantial and thick enough to hold self-tapping screws. Make sure the area on the back side of the mounting surface is clear of obstructions. We recommend a minimum thickness of 3/32" (.093" - 2.4 mm) in aluminum and 5/64 (.078"-2mm) in steel. See the chart in Figure 5.2.1 to determine the correct pilot hole size.

### 5.2.1 HOLSTER MOUNTING

Select proper location for mounting holster, preferably inside a storage compartment. Panel space required will be 6.5" x 8.0" (165 x 203mm). Refer to Figure 5.2.1 for hole dimensions. Holster can be used as template.

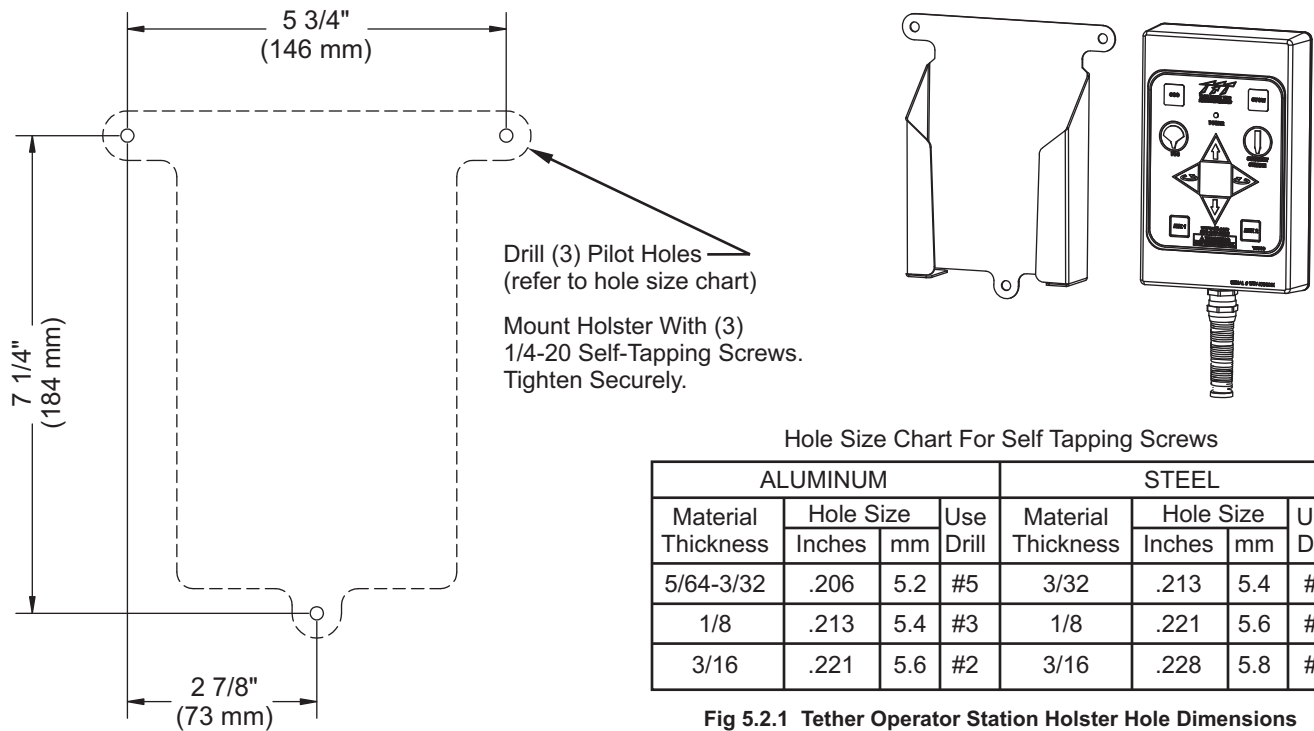
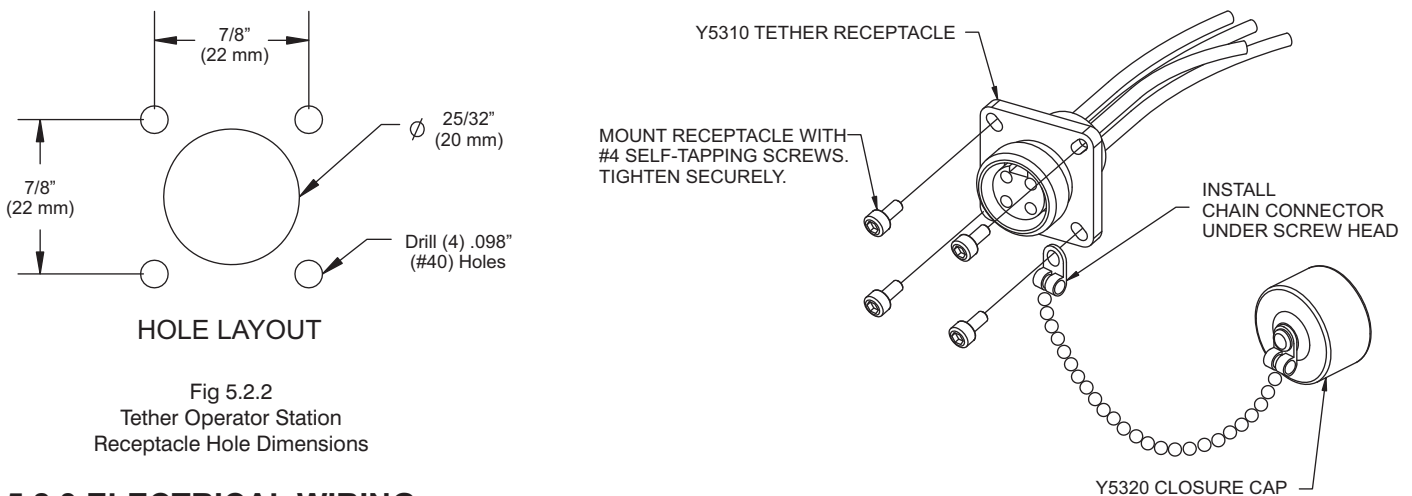

Fig 5.2.1 Tether Operator Station Holster Hole Dimensions

### 5.2.2 RECEPTACLE MOUNTING

Select proper location for mounting receptacle. Receptacle is 1-1/4" x 1-1/4" and 1/2" deep. (32 mm x 32 mm x 13 mm) Allow extra room behind receptacle for wires. Refer to Figure 5.2.2 for hole dimensions.



### 5.2.3 ELECTRICAL WIRING

See figure 5.0 for typical connections. The 4-conductor cable from the receptacle needs to be connected to power (red & black) and to the communication link (blue & white) from the monitor. Refer to Figure 5.1.2 for typical cable preparation.

### 5.3 WIRELESS MONITOR OPERATOR STATION (YE-RF-##)

The YE-RF-## Wireless Operator Station is supplied with a radio board that needs to be installed in the monitor control box and a storage bracket.

#### 5.3.1 MOUNTING STORAGE BRACKET

The storage bracket is supplied with (3) 1/4-20 stainless steel self-tapping screws. Make sure the material beneath the bracket is substantial and thick enough to hold self-tapping screws. Make sure the area on the backside of the mounting surface is clear of obstructions. We recommend a minimum thickness of 3/32" (.093" - 2.4 mm) in aluminum and 5/64 (.078"-2mm) in steel. See the chart in Figure 5.3.1 to determine the correct pilot hole size.

Select proper location for mounting storage bracket. Panel space required will be 6.0" x 11.2" (152 x 285mm). Refer to Figure 5.3.1 for hole dimensions. Bracket can be used as a template. **Be sure spring is in position.**

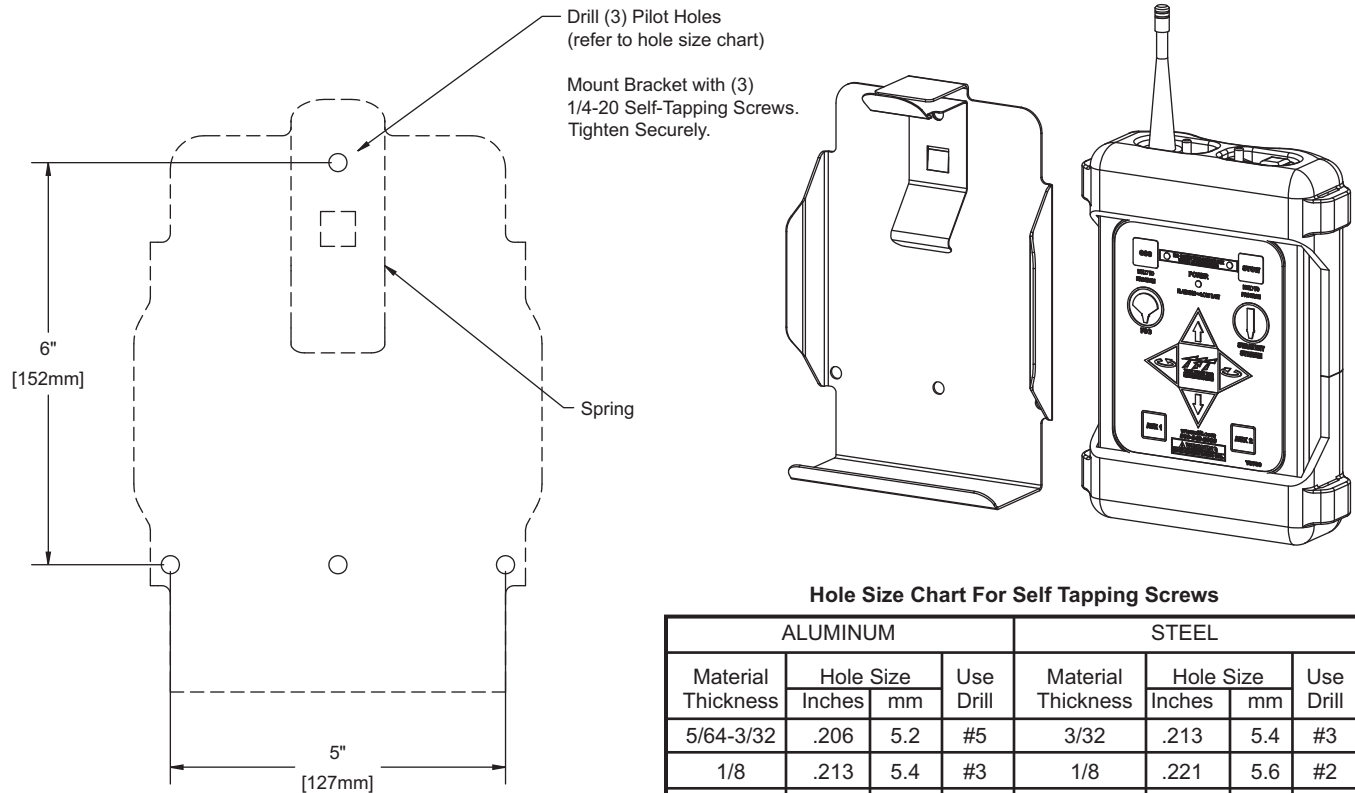

Fig 5.3.1 Wireless Operator Station Storage Bracket Hole Dimensions

Hole Size Chart For Self Tapping Screws

ALUMINUM				STEEL			
Material Thickness	Hole Size		Use Drill	Material Thickness	Hole Size		Use Drill
	Inches	mm			Inches	mm	
5/64-3/32	.206	5.2	#5	3/32	.213	5.4	#3
1/8	.213	5.4	#3	1/8	.221	5.6	#2
3/16	.221	5.6	#2	3/16	.228	5.8	#1

#### 5.3.2 INSTALLING RADIO

- 1) Turn off power and remove lid from monitor control box. Be careful to open lid slowly as lid will be connected to communication board by a flat cable.
- 2) Unplug connector with blue & white wires and remove the small communication board on the far left.
- 3) Attach antenna connector to radio board with the cable in the orientation. (Fig 5.3.2a) Note, in some RC monitors, cable tie may need to be cut to attach antenna.
- 4) Plug radio board into communication board. (Fig 5.3.2b) Be careful to line up pins.
- 5) Plug communication board/radio board into main board. Press down to seat securely.
- 6) Insert connector with blue & white wires into communication board.
- 7) Replace lid onto box. Be sure to guide flat cable down onto motor boards and to not pinch any wires between lid and box.
- 8) Tighten lid screws equally in a criss-cross pattern.

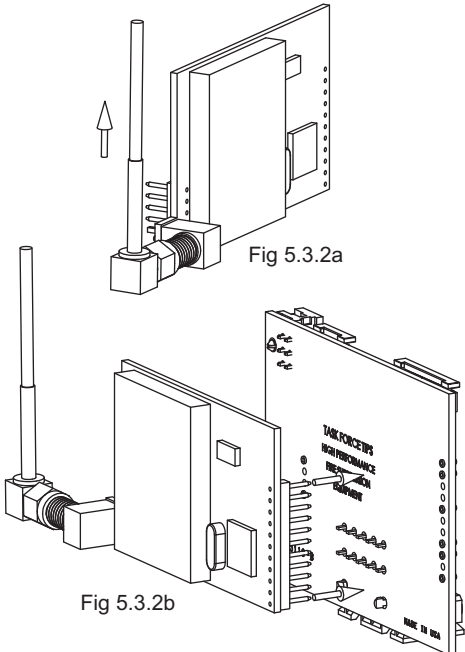

**5.3.3 TEACHING ID CODE:** **NOTE: When the operator station is purchased at the same time as RC monitor, handheld unit will be pre-taught at factory.**

Every monitor has a unique ID code that must be “taught or transferred” to the handheld unit. This unique ID code allows multiple monitors to be used in one location without interference. Perform the following procedure to teach the handheld unit.

**On Handheld Unit:**

- Press POWER button to turn on electronics.
- Press and hold both LEFT & RIGHT buttons for 5 seconds.
- Continue to press LEFT & RIGHT buttons and then press UP button for 2 seconds.
- Release buttons. OSC & STOW lights will flash rapidly to indicate that the unit is in teach mode.

**On Monitor Control Box:**

- Apply power to monitor.
- Press and hold both LEFT & RIGHT buttons for 5 seconds.
- Continue to press LEFT & RIGHT buttons and then press UP button for 2 seconds.
- Release buttons. OSC & STOW lights will flash rapidly to indicate that the unit is in teach mode.
- OSC & STOW lights on handheld unit will stop flashing after ID code is transferred.
- Press DOWN button on monitor control box to exit teach mode.
- Cycle power off and back on to monitor.

**5.3.4 CHANGING BATTERIES:**

**Four (AA) Batteries, Lithium Recommended**

- Remove two (2) screws on backside of handheld unit and slide bottom half of rubber bumper off enclosure.
- Replace batteries verifying that polarity is correct.
- Replace rubber bumper and retaining screws.

**CAUTION** Properly dispose of old batteries. Do not puncture, incinerate, or disassemble batteries. Do not mix battery types.

**5.4 JOYSTICK MONITOR OPERATOR STATION (Y4E-JS)**

This operator station allows the monitor to be controlled by a joystick. The installer will need to mount the joystick control and connect the cable to a receptacle or terminal box with power and communication connections. The joystick control needs to be mounted in a weatherproof location, for example, inside the cab of the truck.

**5.4.1 MOUNTING**

Select proper weatherproof operating location. Joystick control box requires 4 3/4" x 4 3/4" x 4" (121mm x 121mm x 102mm) of space and the joystick extends 6 1/4" (159mm) above the control box. Threaded mounting holes are located on the bottom of the joystick control box. Refer to Figure 5.4.1.1 for hole layout.

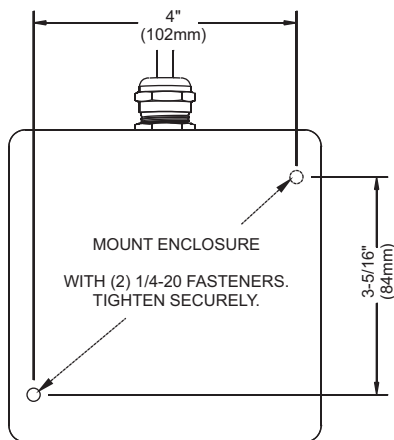

Fig 5.4.1.1 Joystick Operator Station Hole Dimensions

Install joystick instruction label nearby for quick operation reference.

**\*SMART STREAM**  
1) NOZZLE STOPS AT FULL FOG  
2) PRESS AGAIN FOR FLUSH

**TO OSCILLATE:**  
Press & release OSC button.  
(Pattern must be programmed first.)

**TO STOW:**  
Press & release STOW button.  
(Programmable, refer to manual.)

---

**OSCILLATE PATTERN PROGRAMMING:**

- 1) Move monitor to starting point of pattern.
- 2) Press & hold OSC button until LED blinks. LED will continue to blink in program mode.
- 3) Move monitor to 2nd point, press OSC button. LED will blink rapidly to acknowledge position.
- 4) Repeat until pattern is complete.
- 5) Press & hold OSC button until LED turns off.

**NOTE: PATTERN WILL BE CLEARED UPON POWER LOSS.**

Where New Ideas Flow™ • 800-348-2686 • www.tft.com

Fig 5.4.1.2 Joystick Instruction Label

**5.4.2 ELECTRICAL WIRING**

This operator station will have a factory installed 4-conductor cable with a plug on the end. The installer will need to mount the mating receptacle (YE-RECEP-4) in a suitable location. Refer to Sections 5.2.2 and 5.2.3 for proper receptacle installation and wiring.

When a Valve Kit is used (YE-VK-PH), the receptacle is provided on the valve interface enclosure and is pre-wired to the control system.

**NOTE: THE JOYSTICK TRIGGER IS FACTORY WIRED TO THE AUX2 CONNECTION. FOR TRIGGER-CONTROLLED VALVE OPERATION, THE VALVE INTERFACE RELAYS MUST BE CONFIGURED FOR AUX2.**

## 5.5 TOGGLE SWITCH MONITOR OPERATOR STATION (Y4E-TS)

This operator station allows the monitor to be controlled by three toggle switches. The installer will need to mount the operator station and connect the cable to the monitor and power.

### 5.5.1 ENCLOSURE MOUNTING

Select proper operator location. Enclosure is designed to be surface mounted and the size is 5" x 3 1/8" (127 x 80mm). Height to top of switches is 3 1/8" (80mm). Refer to Figure 5.5.1 for mounting hole dimensions.

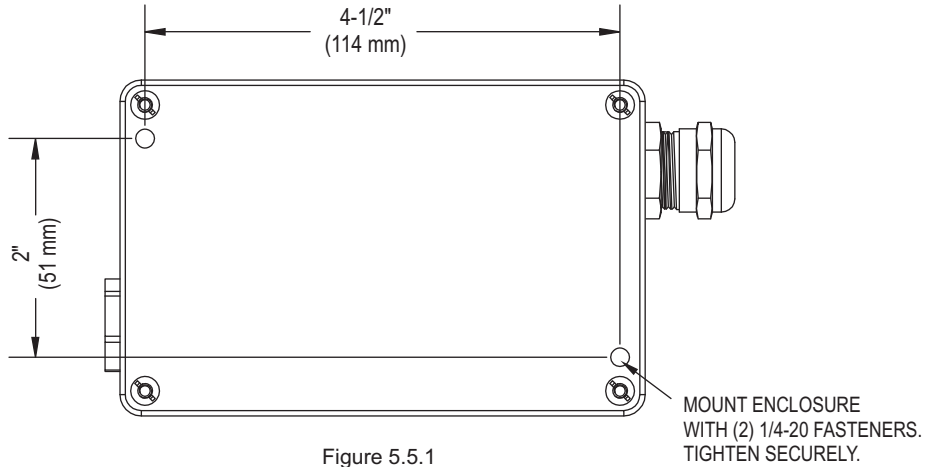

Figure 5.5.1  
Toggle Switch Operator Station Hole Dimensions

### 5.5.2 ELECTRICAL WIRING

See figure 5.0 for typical connections. The 4-conductor cable from the operator station needs to be connected to power (red & black) and to the communication link (blue & white) from the monitor. Refer to Figure 5.1.2 for typical cable preparation

## 5.6 COMMUNICATION INTERFACE BOX (Y4E-COMM)

This Communication Interface Box converts discrete input signals into serial communications for controlling the monitor. The discrete input signals can be from a joystick, toggle switches, relay contacts or Canbus output module. The interface box accepts +12/24 VDC signals, but can be field changed to accept ground signals. The installer will need to mount the interface box and connect the cable to the monitor and power.

### 5.6.1 ENCLOSURE MOUNTING

Select proper enclosure location. Enclosure is designed to be surface mounted and the size is 5" x 3 1/8" (127 x 80mm). Height of enclosure is 2 3/8" (60mm). Refer to Figure 5.5.1 for mounting hole dimensions.

### 5.6.2 ELECTRICAL WIRING

See figure 5.0 for typical connections. The 4-conductor cable from the communication interface box needs to be connected to power (red & black) and to the communication link (blue & white) from the monitor. Refer to Figure 5.1.2 for typical cable preparation.

See figure 5.6.2 for connecting INPUTS cable.

Function	Interface Box Cable Color
UP	WHITE
DOWN	BLUE
LEFT	YELLOW
RIGHT	BROWN
FOG	GREEN
STREAM	ORANGE
(-) BLACK	BLACK
(+) RED	RED

Figure 5.6.2  
Communication Interface  
Wire Color/Function

### 5.6.3 INPUTS SIGNAL CONFIGURATION

The Communication Interface Box is shipped from the factory configured to accept +12/24 volt DC input signals, but can be field changed to accept ground input signals. To change the configuration:

1. Remove lid from enclosure.
2. Locate DIP switches on communication board.
3. Slide DIP switch #4 to the OFF position to select GROUND inputs or slide to the ON position to select VOLTAGE inputs.
4. Replace lid. Verify rubber seal is clean and undamaged. Verify that no wires are caught between lid and box.

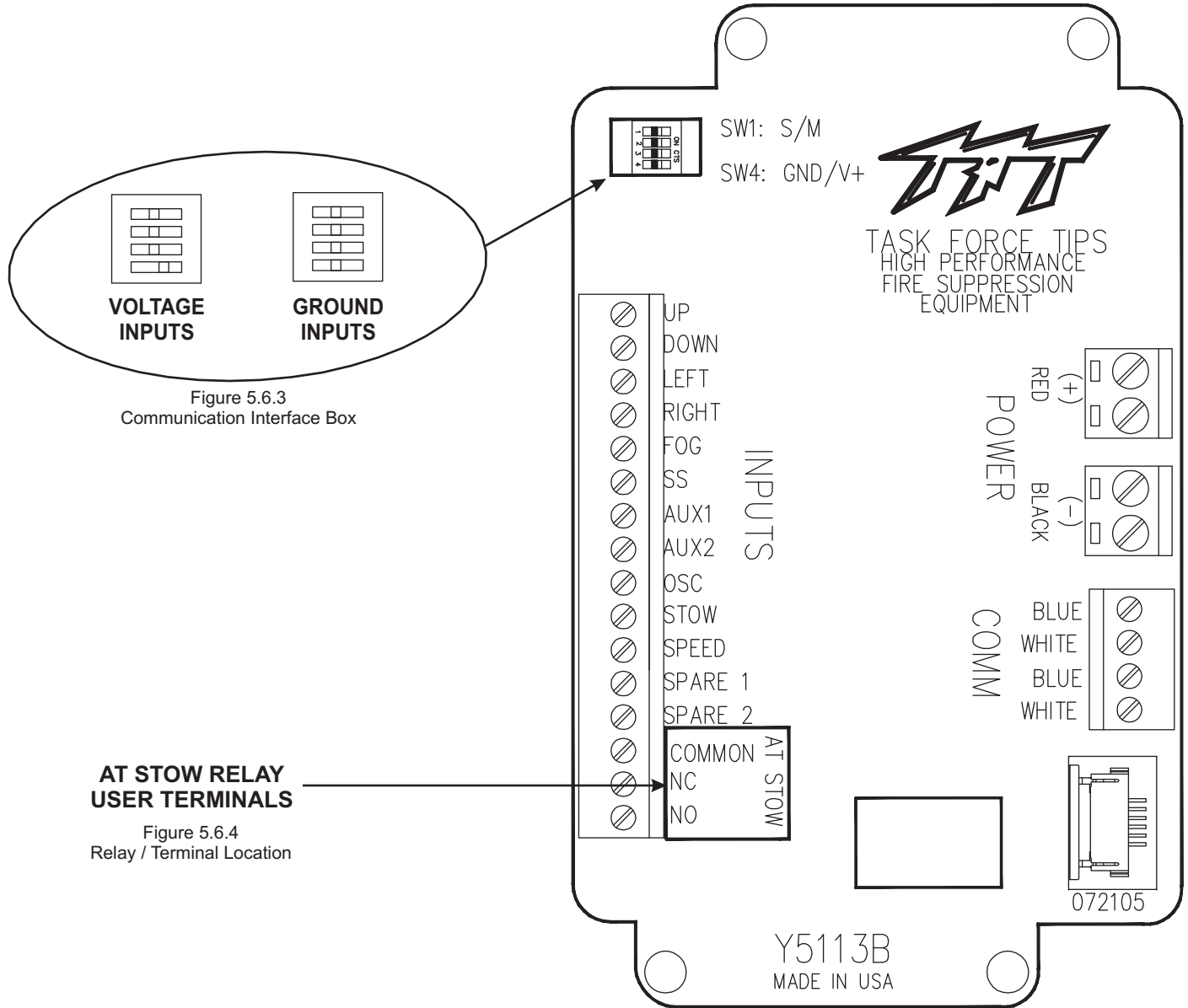

**AT STOW RELAY  
USER TERMINALS**

Figure 5.6.4  
Relay / Terminal Location

### 5.6.4 COMMUNICATION INTERFACE BOX WITH AT STOW RELAY (Y4E-COMM)

The Communication Interface Box provides feedback for the user that the monitor is in the AT STOWED position. The Interface Box contains a circuit board that is equipped with a relay that is energized when the monitor is in use and de-energized when the monitor reaches its final STOW location. The contact rating of the relay is 1 amp @ 30VDC for resistive loads and 0.2 amps @ 30VDC for inductive loads.

**The AT STOW relay has one Form-C contact (common, normally open, normally closed) that can be used. The figure above shows the terminal blocks available for user wiring.**

## 5.7 MONITOR POSITION DISPLAY (Y4E-DISP)

The monitor position display is supplied with a 10' (3 m) long 4-conductor cable. The installer will need to surface mount the enclosure in a dry area and connect the cable to power and the communication link of the monitor. Display is designed for use with 180° total horizontal axis travel.

### 5.7.1 ENCLOSURE MOUNTING

Select proper location for display. The display is not weatherproof and needs to be inside a protected area such as in the cab.

MOUNT ENCLOSURE WITH  
(2) #10 FASTENERS.  
TIGHTEN SECURELY.

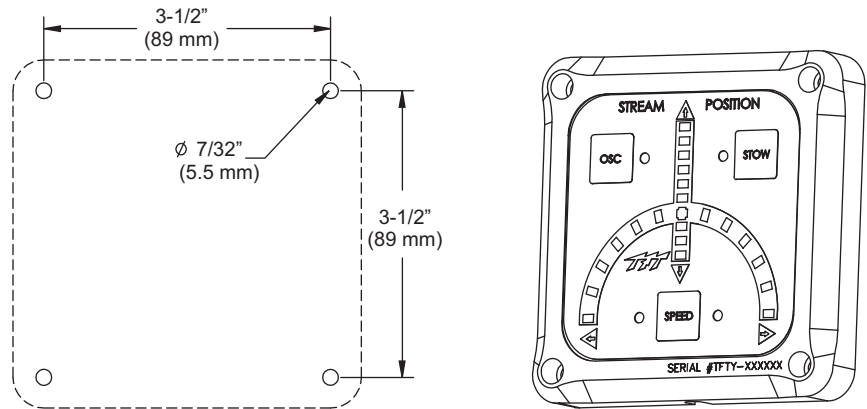

Fig 5.7.1 - Monitor Position Display Hole Dimensions

### 5.7.2 ELECTRICAL WIRING

See figure 5.0 for typical connections. The 4-conductor cable from the monitor position display needs to be connected to power (red & black) and to the communication link (blue & white) from the monitor. The cable exits the back side of the enclosure and can be installed straight back thru an opening in a panel or laid into groove in enclosure for flush mounting. Refer to Figure 5.1.2 for typical cable preparation.

## 5.8 REMOTE AUXILIARY INTERFACE BOX (YE-REMAUX)

The Remote Auxiliary Interface Box allows a user to utilize the AUX1 and AUX2 buttons located on the monitor operator station or any remote operator station. The Interface Box is equipped with two relays that can operate lights, interface to a valve controller or in some cases operate a valve directly, etc. The contact rating of the relay is 16 amps @ 30VDC for resistive loads and 8 amps @ 30VDC for inductive loads.

The installer will need to mount the interface box and connect the cable to power and the communication link of the monitor.



**The Interface Box provides no overload protection for the device it is controlling. Failure to provide overload protection will damage relay contacts, which will disable device being controlled.**

### 5.8.1 ENCLOSURE MOUNTING

Select proper enclosure location. Enclosure is designed to be surface mounted and the size is 5" x 3 1/8" (127 x 80mm). Height of enclosure is 2 3/8" (60mm). Refer to Figure 5.8.1 for mounting hole dimensions.

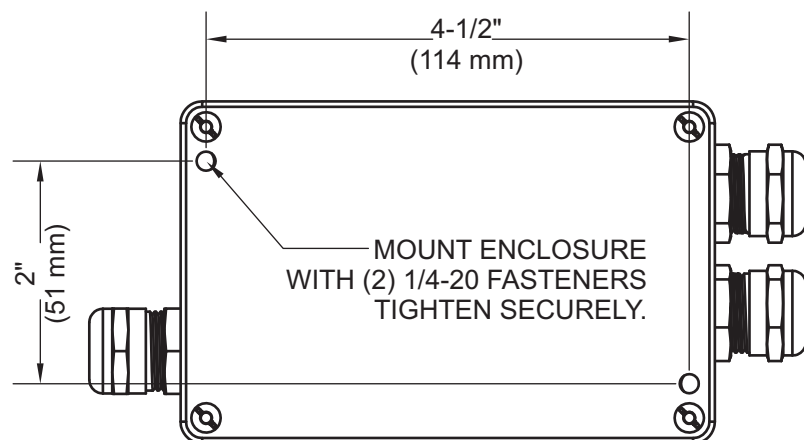

Figure 5.8.1  
Remote Aux. Interface Box Hole Dimensions

### 5.8.2 ELECTRICAL WIRING

See figure 5.0 for typical connections. The 4-conductor cable from the communication interface box needs to be connected to power (red & black) and to the communication link (blue & white) from the monitor. Refer to Figure 5.1.2 for typical cable preparation.

Each relay has one Form-C contact (common, normally open, normally closed) that can be used.



### 5.8.3 CONFIGURATION

The two relays on the circuit board can be individually configured as AUX1 or AUX2. Also the actuation of each relay can be configured to be momentary or latched. See Figure 5.9.3 for relay configuration DIP switch settings.

1. Remove lid from interface box.
2. Locate DIP switches on board and select configuration.
3. Replace lid. Verify rubber seal is clean and undamaged. Verify that no wires are caught between lid and box.

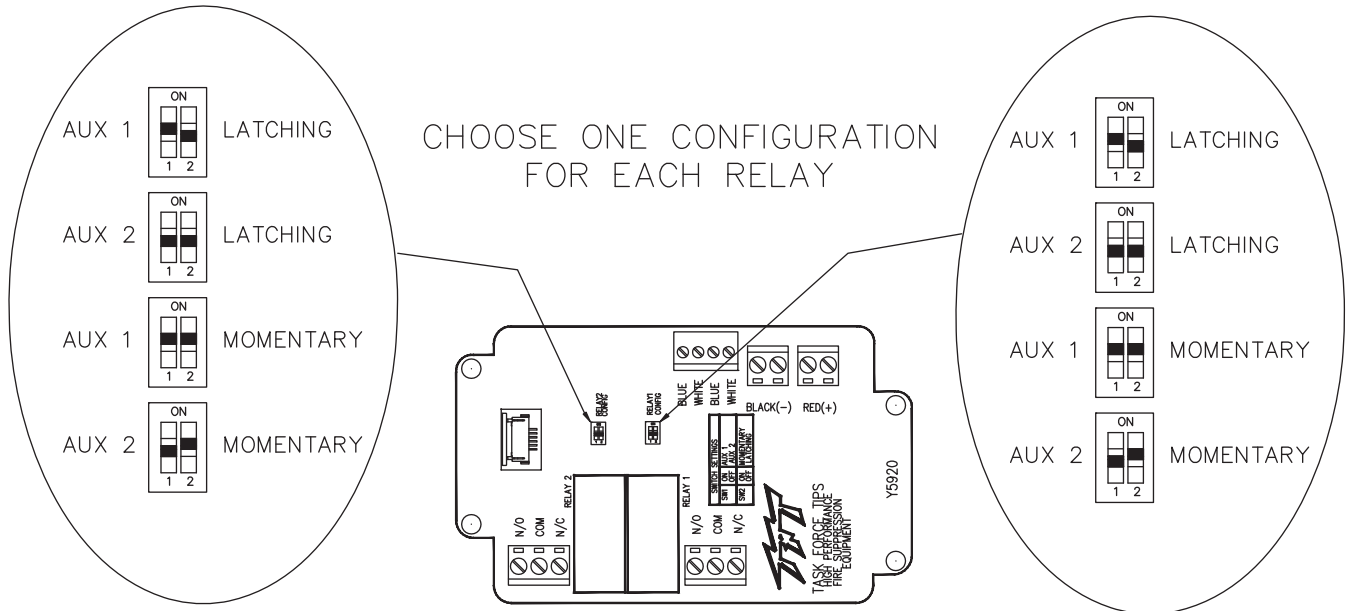

Figure 5.8.3 Relay Configuration

### 5.9 CONNECTING MONITOR CABLE DIRECTLY TO PROTECTED POWER SUPPLY

The electric RC monitor has an operator station, which is fully functional, mounted on the monitor. If no other operator stations are selected, with the exception of the wireless radio remote, the installer will only need to connect power to complete the installation. Route cable from monitor and connect to a protected circuit from the truck's power distribution center. Connect the red wire to positive and the black wire to negative (ground). Cut and discard blue and white wires.

### 5.10 ELECTRICAL RC MONITOR AERIAL TRUCK INSTALLATION

Two versions of the RC monitor have been designed for installation on aerial device trucks, the "-L" and "-P" versions. The "-L" version is supplied with one cable for connecting discrete inputs into the electronics enclosure, typically connections to a Canbus output module or toggle switches located at the turntable. The "-P" version is supplied with two cables for connecting discrete inputs, one cable typically for controls located in the basket and one cable for controls located at the turntable.

#### 5.10.1 ELECTRONICS ENCLOSURE MOUNTING

Select proper enclosure location. Enclosure is designed to be surface mounted and the size is 5 3/4" x 8 3/4" (146 x 222mm). Height of enclosure is 2 1/4" (57mm). Refer to Figure 5.10.1 for mounting hole dimensions.

#### 5.10.2 ELECTRICAL WIRING

On aerial devices, the installer will supply the required cables that run up the ladder or boom. Be sure to perform voltage drop calculations to verify that the supply voltage will remain at an acceptable level during monitor operation.

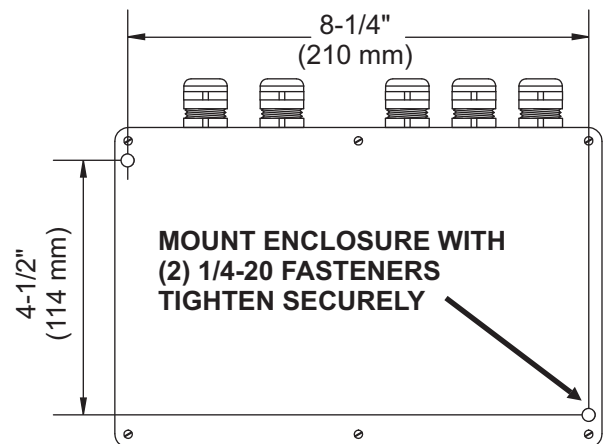

Fig 5.10.1 Electrical Enclosure Mounting Hole Dimensions

### 5.10.2.1 LADDER INSTALLATION ELECTRICAL WIRING (-L MODELS)

The electronics enclosure converts discrete input signals into serial communications for controlling the monitor. The discrete input signals can be from a joystick, toggle switches, relay contacts or Canbus output module. The electronic interface accepts +12/24 VDC signals, but can be field changed to accept ground signals.

The electronics enclosure is configured so that signals connected to the PRIMARY CONTROL cable will override any other operator stations (see section 6.2.1).

See Figure 5.10.2.1 for wiring connections.

**NOTE: To avoid excessive voltage drop at monitor operator station, cable selection is critical. Voltage supplied to ELECTRONICS ENCLOSURE should not fall below 11 volts when monitor is in operation.**

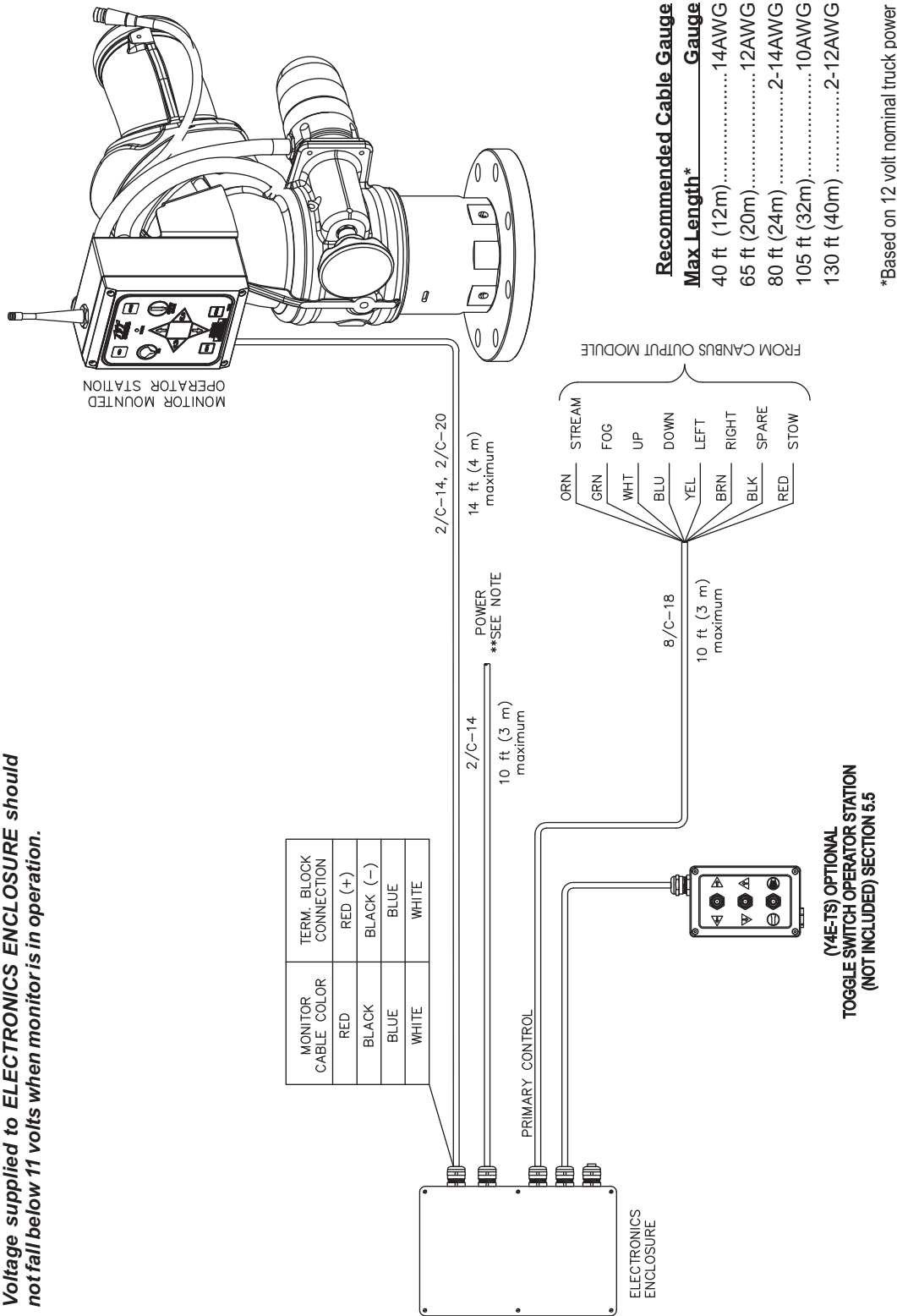

Figure 5.10.2.1  
Electrical Components  
(ladder installations)

### 5.10.2.2 PLATFORM INSTALLATION ELECTRICAL WIRING (-P MODELS)

The electronics enclosure converts discrete input signals into serial communications for controlling the monitor. The discrete input signals can be from a joystick, toggle switches, relay contacts or Canbus output module. The electronic interface accepts +12/24 VDC signals, but can be field changed to accept ground signals.

The electronics enclosure is configured so that signals connected to the PRIMARY CONTROL cable will override any other operator stations (see section 6.2.1).

See Figure 5.10.2.2 for wiring connections.

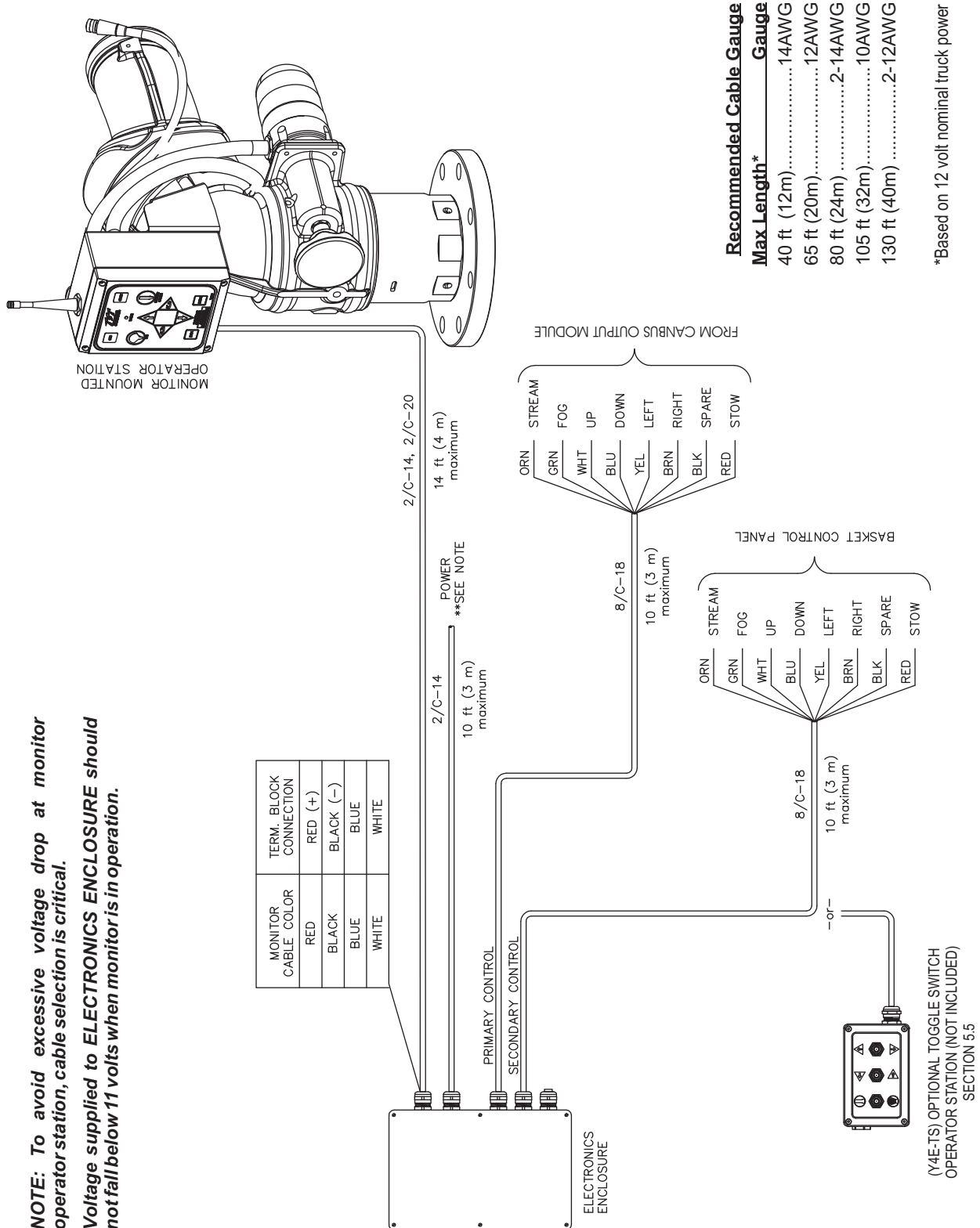

Figure 5.10.2.2  
Electrical Components  
(platform installations)

### 5.10.3 ELECTRONICS ENCLOSURE WITH AT STOW RELAY

The electronics enclosure provides feedback for the user that the monitor is in the AT STOWED position. This electronics enclosure contains a circuit board that is equipped with a relay that is energized when the monitor is in use and de-energized when the monitor reaches its final STOW location. The contact rating of the relay is 1 amp @ 30VDC for resistive loads and 0.2 amps @ 30VDC for inductive loads.

#### 5.10.3.1 ELECTRIC CONNECTIONS

The AT STOW relay has one Form-C contact (common, normally open, normally closed) that can be used. The figure below shows the terminal blocks available for user wiring.

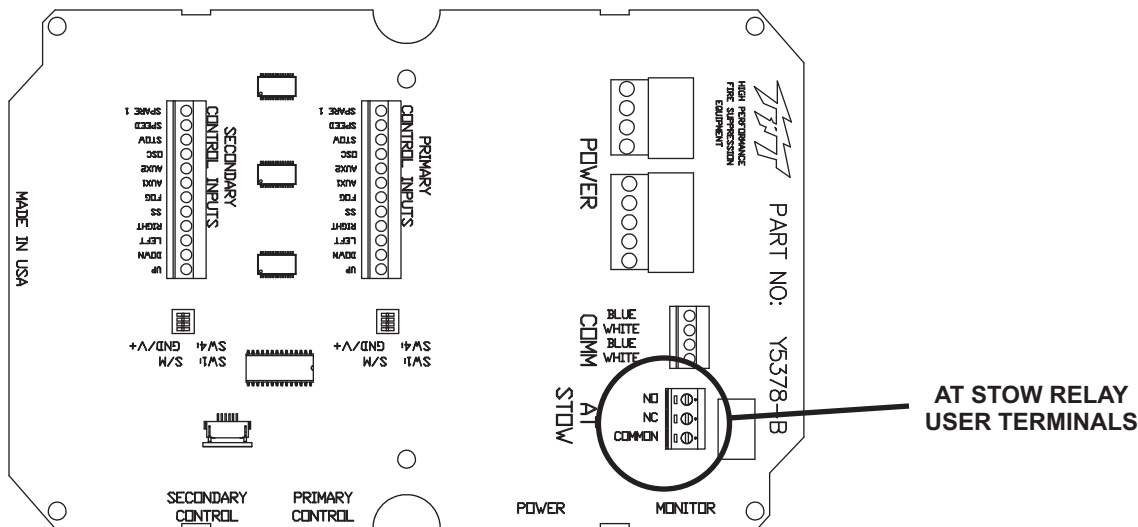

Figure 5.10.3.1  
Relay / Terminal Location

### 5.11 ELECTRIC NOZZLE ACTUATOR WIRING

The electric RC monitor is designed to control and is factory wired for a TFT electric actuated nozzle. Task Force Tips nozzles are available with a male cord plug. After mounting the appropriate nozzle onto the monitor, plug the male cord from the nozzle into the female cord located on the outlet of the monitor. Make sure the two coupling nuts are tightened securely to ensure a proper watertight seal.

If retrofitting an existing TFT nozzle, a male cord plug (TFT #Y5480) can be purchased and installed in place of the existing actuator cord. Please consult factory for installation.

### 5.12 VALVE KIT (YE-VK-PH)

This kit includes a water valve with plug-in electrical connection and an interface control for “plug and play” wiring for power, water valve, monitor, joystick control and an extra operator station. The installer will need to mount the water valve and the interface box. The interface box is weatherproof and may be installed at any convenient location to route and connect all control system cables.

#### 5.12.1 VALVE MOUNTING

The water valve may be mounted at any location within the plumbing and at any orientation. The wiring and connector from the valve actuator should be protected from pulling and abrasion. The valve inlet and outlet are both 2” NPT connections and the valve/actuator dimensions are 5.52” (140mm) face-to-face, 6.49” (165mm) wide, and 9.78” (248mm) tall.

#### 5.12.2 INTERFACE ENCLOSURE MOUNTING

The interface box should be mounted at a location to allow all factory supplied cables to reach and connect. The enclosure is designed to be surface mounted and the size is 5 3/4” x 8 3/4” (146 x 222mm). Height of enclosure is 2 1/4” (57mm). Clearance is needed for the cables that extend from one side. Threaded mounting holes are located on the bottom of the interface box. Refer to Figure 5.10.1 for hole layout.

#### 5.12.3 ELECTRICAL WIRING

All wiring connections are made with factory installed cables with plugs from the interface box. Each cable is identified at its exit from the interface box. Cables should be routed to the appropriate device and plugged into the mating receptacle. The power cable should be routed to a terminal box and connected to the power source. Refer to Figure 5.0 for typical connections.

## 5.12.4 CONFIGURATION

The valve interface control is factory set for AUX2 and Momentary operation. This configuration is most suitable for joystick control of monitor and valve functions. If another operator station with keypad is used, it may be desired to change from momentary to latching operation so that the AUX2 key may be pressed and released once to open the water valve, then pressed and released again to close the valve.

The two relays on the circuit board can be individually configured as AUX1 or AUX2. Also the actuation of each relay can be configured to be momentary or latched. See Figure 5.8.3 for relay configuration DIP switch settings.

1. Remove lid from interface box.
2. Locate DIP switches on board and select configuration.
3. Replace lid. Verify rubber seal is clean and undamaged. Verify that no wires are caught between lid and box.

**NOTE: BOTH DIP SWITCHES MUST BE CONFIGURED THE SAME FOR PROPER WATER VALVE CONTROL. FAILURE TO DO SO MAY RESULT IN DAMAGE TO CIRCUIT BOARD.**

## 6.0 OPERATION

### 6.1 MANUAL MODEL

#### 6.1.1 HORIZONTAL ROTATION CONTROL

A handwheel controls the monitor's horizontal rotation direction. Clockwise rotation of the handwheel moves the nozzle to the left and counter-clockwise rotation to the right. Approximately 14 turns of the handwheel will give a 90 degree change in horizontal rotation direction.

#### 6.1.2 ELEVATION CONTROL

A handwheel controls the monitor's elevation direction. Clockwise rotation of the handwheel raises the elevation and counter-clockwise lowers it. About 50 turns of the handwheel will give the complete 135 degree elevation travel range of the monitor.

#### 6.1.3 TILLER BAR MODEL

On the Tiller Bar model the horizontal rotation is changed by pushing or pulling horizontally on the Tiller Handle. Twisting the Rotation Locking Knob clockwise will increase the drag on the lower swivel joint to "lock" the monitor in a particular direction. See figure 6.1.3 for the Tiller Bar model controls.

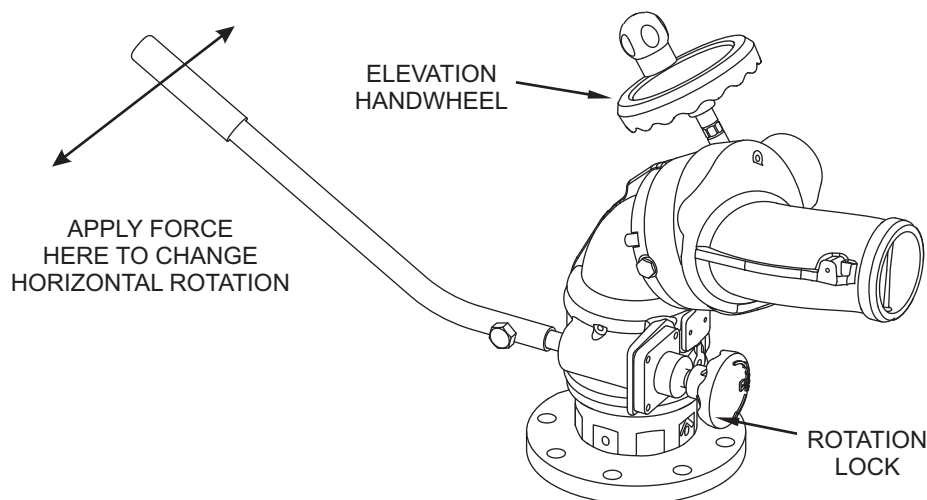

Figure 6.1.3  
Tiller Bar Model Controls

## **CAUTION**

Injury can result from the monitor changing direction due to an off center nozzle reaction. An off center nozzle reaction may be caused by debris in the nozzle causing an asymmetrical stream. Always keep the rotation lock tight when not rotating the monitor. Always keep one hand on the tiller handle when loosening the locking knob. Where continuous 360 degree rotation of the monitor is not needed it is recommended that the Horizontal Rotation Stop Bolts (see section 4.4 for Stop Bolt locations) be installed to reduce any chance of the monitor spinning due to an off center nozzle reaction caused by debris trapped in the nozzle.

## 6.2 ELECTRICAL MODEL

### 6.2.1 OPERATOR STATIONS

The electric Monsoon RC monitor has five different styles of operator stations for use in various locations on the fire truck or fire ground.

The design of the operator station communications allows users to override commands on other stations. The "last" button pressed has control. The overridden user can regain control by releasing their button and pressing again.

Platform and ladder electronics enclosures are pre-configured for one set of inputs to have a master override feature. The operator station connected to these inputs, typically at the base of the aerial, will override any other operator station.

Any operator station with a communication board or connected to a communication board can be field configured with the master override feature. This allows the user to setup an operator station on the fire truck or fire ground as the master override station. See Section 6.2.2 for details.

#### 6.2.1.1 MONITOR MOUNTED OPERATOR STATION

This operator station is factory installed on the monitor and is used by personnel at the monitor.

#### 6.2.1.2 PANEL MOUNT OPERATOR STATION (Y4E-RP)

This operator station is installed on the truck, for example the pump operator's panel. It is used to operate the monitor from a location on the truck.

#### 6.2.1.3 TETHER OPERATOR STATION (Y4E-CT-##)

This operator station is tethered to the truck with either a 30 foot (9 meter) cable or a 100 foot (30.5 meter) cable. It is used to move slightly away from the truck to get a better view for redirecting the monitor.

#### 6.2.1.4 WIRELESS OPERATOR STATION (YE-RF-##)

The Wireless Operator Station allows a user to move away from the truck to get a better view for redirecting the monitor. This operator station gives the user full control of the monitor including the STOW, OSCillate, and any AUXiliary functions. Every TFT RC monitor is shipped with the antenna pre-mounted in the monitor control box. All the user needs to do is mount the storage bracket and teach the ID code to the handheld unit.

The range of the wireless operator station is 500 ft (152 m) and the handheld unit is powered by four (4) AA batteries, lithium batteries are recommended. Lithium batteries will provide 33 hours of continuous operation. When the battery voltage falls below a set level, the POWER led will begin to flash. At this point there is approximately 3 hours of continuous operation remaining.

The handheld unit will automatically turn off after 5 minutes if no buttons are pressed.

- Press POWER button to turn on electronics.

- Use operator station just like any other wired operator station.

- Press POWER button again to turn off electronics or after 5 minutes of idle operation, handheld unit will automatically turn off.

**NOTE!!!** If after pressing a button, the OSC & STOW leds alternately flash, this indicates no communication link is present with the monitor. The handheld unit is out of range or cannot establish a link with the monitor. Move to a different location and then retry, also verify monitor has power applied.

#### 6.2.1.5 JOYSTICK OPERATOR STATION (Y4E-JS)

This operator station is installed in a protected location and allows the monitor to be controlled by a joystick.

#### 6.2.1.6 TOGGLE SWITCH OPERATOR STATION (Y4E-TS)

This operator station allows the monitor to be operated by three toggle switches.

### 6.2.2 MASTER OVERRIDE FEATURE (DIP#1)

Any operator station with a communication board can be reconfigured with the master override feature. These stations include the Y4E-RP, Y4E-CT-30, Y4E-CT-100, Y4E-TS, Y4E-JS or any inputs connected to an Y4E-COMM. To enable the master override feature on an operator station follow these steps:

1. Remove lid from enclosure.
2. Locate DIP switches on communication board.
3. Slide DIP switch #1 to the ON position.
4. Replace lid. Verify rubber seal is clean and undamaged.  
Verify that no wires are caught between lid and box.

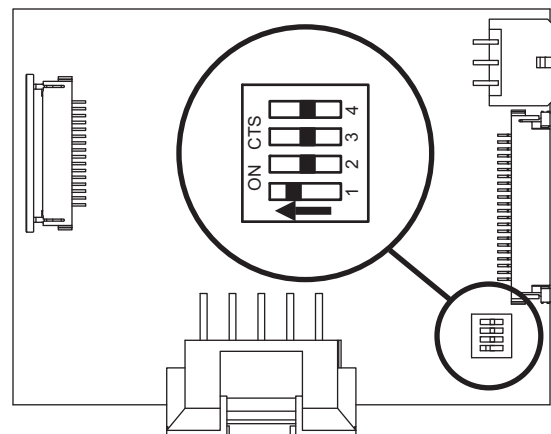

Figure 6.2.2  
Master Override Setup

## 6.2.3 STOW FEATURE

The STOW position needs to be programmed before use. The monitor needs to “find” two (2) hard stops, one for each axis, before the monitor can move to the STOW position. When programming, the first two commands teach the monitor where to find the hard stops. This insures that the position is accurate. From that point, the programmer can program the move to the STOW position. During normal operation, each time the STOW button is pressed, the monitor moves the nozzle to the full straight stream position, moves to each programmed hard stop, and then moves to the STOW position. While the monitor is performing the STOW feature, pressing any button will stop the monitor.

### 6.2.3.1 PROGRAMMING

STOW programming must be initiated within 1 minute of applying power to monitor. After 1 minute, programming access is blocked. Power must then be cycled to reset 1 minute timer.

Press and hold STOW button (~10 seconds) until light blinks. Release button. Light will continue to blink while in program mode.

#### FIRST AXIS TO MOVE:

Press and release LEFT/RIGHT or UP/DOWN button of axis that will move to first hard stop. Light will blink rapidly when hard stop is reached.

#### SECOND AXIS TO MOVE:

Press and release LEFT/RIGHT or UP/DOWN button of axis that will move to second hard stop. Light will blink rapidly when hard stop is reached.

#### MOVE TO STOW POSITION:

Use LEFT/RIGHT or UP/DOWN buttons to move monitor to first point of stow routine, press and release STOW button. Light will blink rapidly to acknowledge position.

Repeat until pattern is complete (up to 10 points).

Press and hold STOW button until light turns off. Release button.

### 6.2.3.2 STOW PROGRAMMING EXAMPLE

- Press and hold STOW button until LED blinks.
- Press and release UP button, monitor will move until hard stop reached. LED blinks rapidly.
- Press and release RIGHT button, monitor will move until hard stop reached. LED blinks rapidly.
- Press LEFT button to move 45 degrees, Press and release STOW button. LED blinks rapidly.
- Press DOWN button to move 90 degrees, Press and release STOW button. LED blinks rapidly.
- Press and hold STOW button until LED turns off.

## 6.2.4 OSCILLATE FEATURE

The OSCILLATE feature allows the user to program a repeating pattern to control the horizontal and vertical axes of the monitor. While in the OSCILLATE pattern, the monitor will pause while the user changes the stream pattern. Pressing any other button will stop the OSCILLATE pattern.

A label is supplied with each operator station that can be mounted on or near the station as a reminder of how to program the OSCILLATE pattern. The OSCILLATE pattern needs to be programmed before use. The pattern will be cleared each time power is cycled to the monitor.

For fixed monitors, the monitor may be configured to store the program permanently. See section 6.2.4.2.

### 6.2.4.1 PROGRAMMING

- Move monitor to starting point of pattern.
- Press and hold OSC button (~5 seconds) until LED blinks. Release button. LED will continue to blink while in program mode.
- Move monitor to second point, press OSC button. LED will blink rapidly to acknowledge position.
- Repeat until pattern is complete (up to 65 points).
- Press and hold OSC button until LED turns off. Release button.

<b>TO OSCILLATE:</b> Press & release OSC button. (Pattern must be programmed first.)	<b>TO STOW:</b> Press & release STOW button. (Programmable, refer to manual.)	 <b>TASK FORCE TIPS</b> FIRE FIGHTING EQUIPMENT
<b>OSCILLATE PATTERN PROGRAMMING:</b>		
1) Move monitor to starting point of pattern.		
2) Press & hold OSC button until LED blinks. LED will continue to blink in program mode.		
3) Move monitor to 2nd point, press OSC button. LED will blink rapidly to acknowledge position.		
<b>800-348-2686</b> <b>www.tft.com</b>		
Y5705		

Figure 6.2.4.1  
Operator Station Label

### 6.2.4.2 OSCILLATE PATTERN RETAIN FEATURE (DIP #4)

The monitor can be configured so that upon power up, the OSCILLATE pattern is retained. The OSCILLATE pattern will need be programmed at least one time (see section 6.2.4.1). To enable the OSCILLATE pattern retain feature on a monitor follow these steps:

1. Remove lid from monitor operator station.
2. Locate DIP switches on communication board.
3. Slide DIP switch #4 to the ON position.
4. Replace lid. Verify rubber seal is clean and undamaged. Verify that no wires are caught between lid and box.
5. Program OSCILLATE pattern.

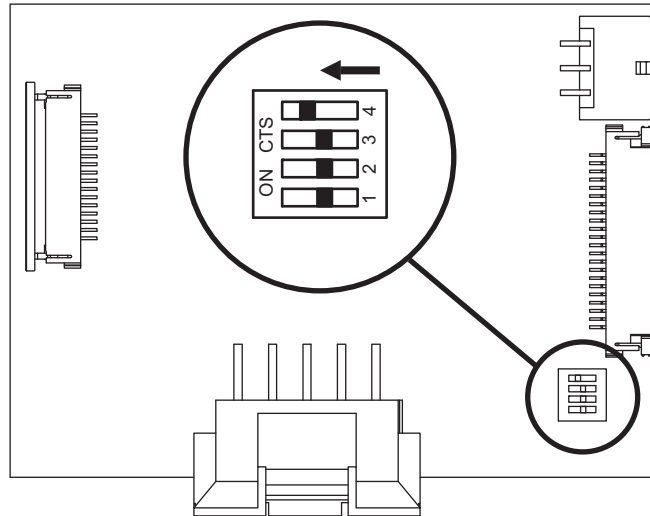

Figure 6.2.4.2  
Oscillate Pattern Retain Setup

### 6.2.5 OPERATOR STATION PANELS

The operator stations are all equipped with the same monitor movement functions. From the operator stations, the operator can command the monitor up, down, left, right and command the nozzle pattern shaper from fog to straight stream. Operator stations supplied with the membrane switch, shown on the left below, allow the operator to program and perform the oscillate and stow features.

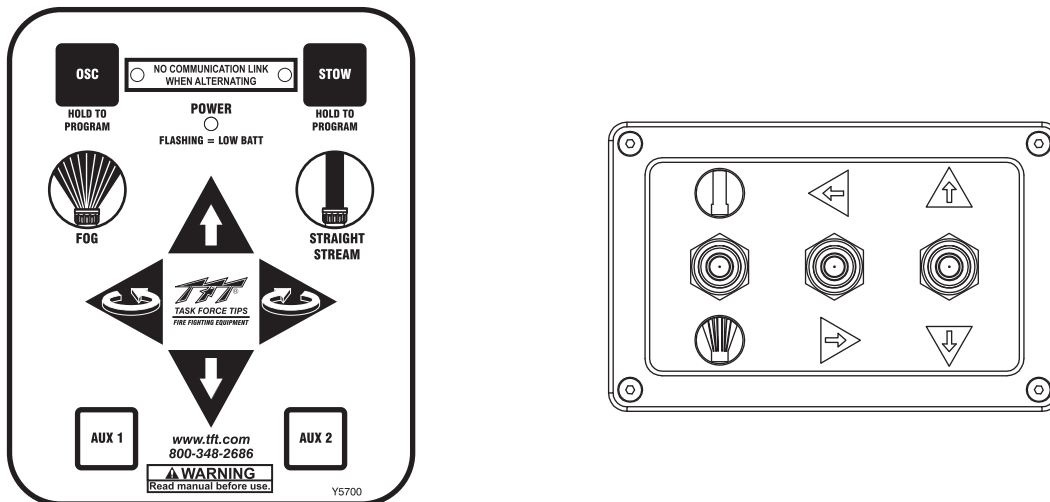

Fig 6.2.5  
Operator Station Button Layouts

Fig 6.2.5  
Operator Station Button Layouts



### 6.2.6 OVERRIDE HANDWHEELS

In the event of electrical system failure on the monitor or fire truck the Monsoon Monitor is factory supplied with handwheels or knobs so the monitor may be manually operated. To make the Monsoon RC more compact the manual override handwheels may be removed. The drive shafts have a hex so a wrench or socket may be used for manual override. Each drive shaft also has a secondary hex at midshaft so the shaft may be shortened by cutting and still have a wrenching hex. The wrenching hexes are shown in figure 6.2.3.

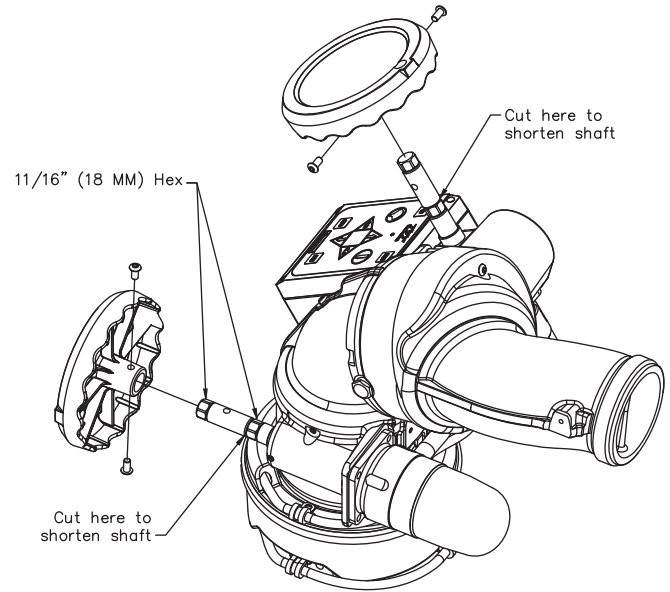

Fig 6.2.3  
Wrenching Hexes on Drive Shafts

### 6.3 RECOMMENDED STOWING POSITION

For truck mounted applications it is recommended that the monitor be stowed in a position such that the monitor's nozzle rests against a bracket or support surface. If a support surface is not available, run the elevation against one of its travel stops to take some of the backlash out of the gear drive. This will minimize bouncing of the nozzle when the apparatus is traveling. Always be sure the monitor is properly stowed before moving the truck and know the overall height to avoid damage from overhead obstructions such as doors or bridges.

### 6.4 FLOWS AND PRESSURES

#### 6.4.1 STACKED TIPS FLOW AND REACH

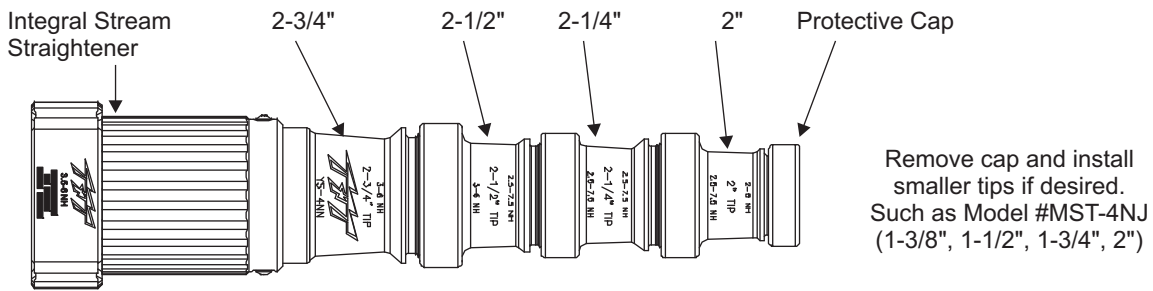

Fig 6.4.1A  
Stacked Tip Model YST-4NN

Nozzle Diameter (inches)	Nozzle Pressure (PSI)							
	50		60		80		100	
	Flow GPM	Reaction lbf	Flow GPM	Reaction lbf	Flow GPM	Reaction lbf	Flow GPM	Reaction lbf
2	840	310	920	380	1060	500	1190	630
2.25	1060	400	1170	480	1350	640	1500	790
2.5	1310	490	1440	590	1660	790	1860	980
2.75	1590	590	1740	710	2010	950	-----	-----

14.5 psi = 1 bar  
1 gpm = 3.785 l/min

Nozzle Diameter (MM)	Nozzle Pressure (BAR)							
	3.5		4.1		5.5		7	
	Flow l/min	Reaction kg	Flow l/min	Reaction kg	Flow l/min	Reaction kg	Flow l/min	Reaction kg
50	3180	140	3480	170	4010	230	4500	290
57	4010	180	4430	220	5110	290	5680	360
64	4960	220	5450	270	6280	360	7040	450
70	6020	270	6590	320	7610	430	-----	-----

FIG 6.4.1B  
Stacked Tip Flow Table

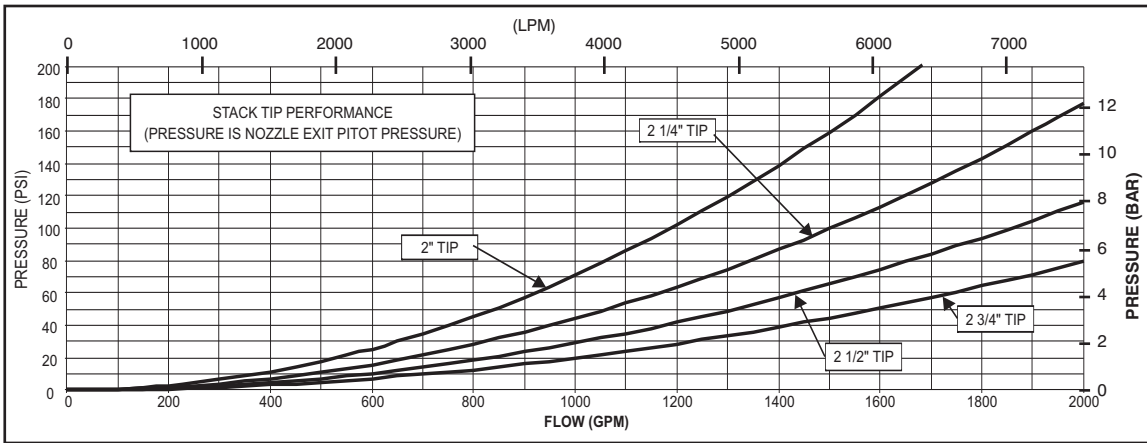

Fig 6.4.1C  
Stacked Tip Flow Graph

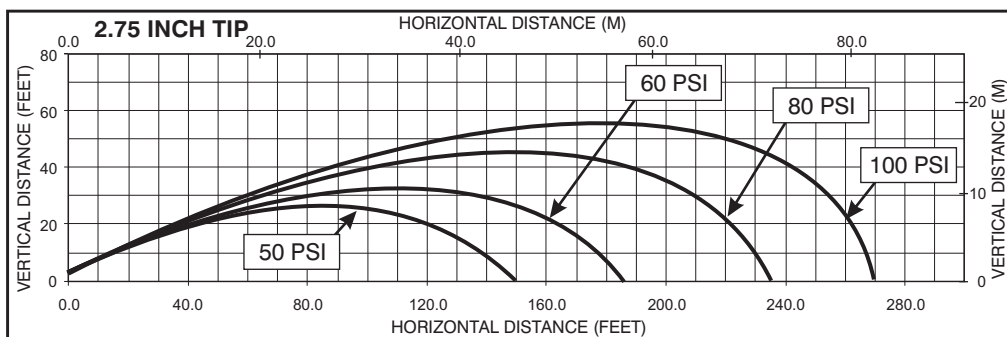
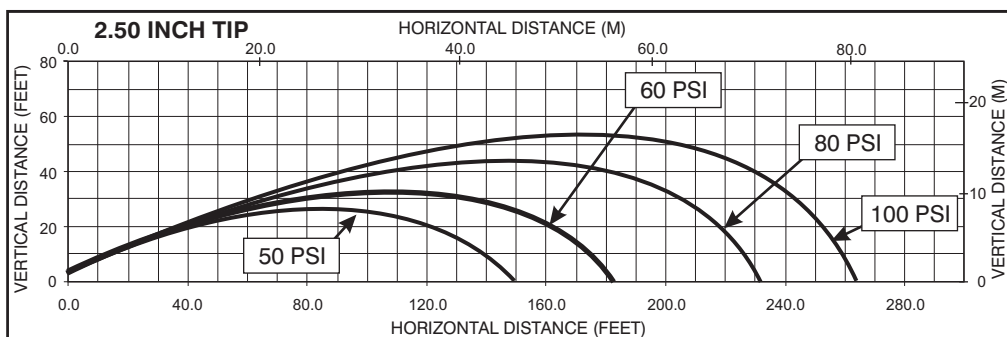
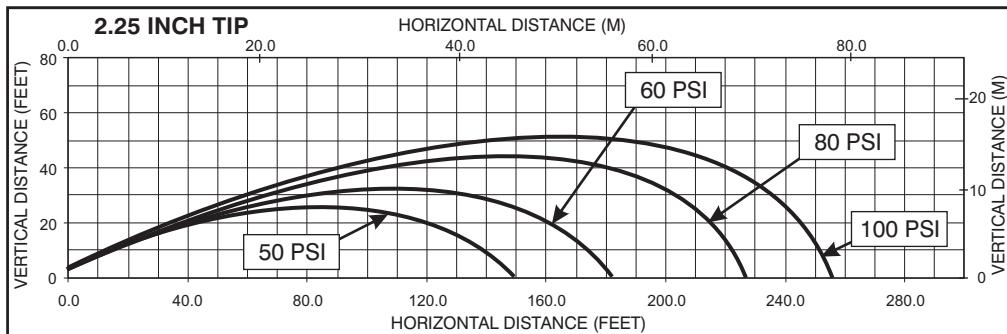
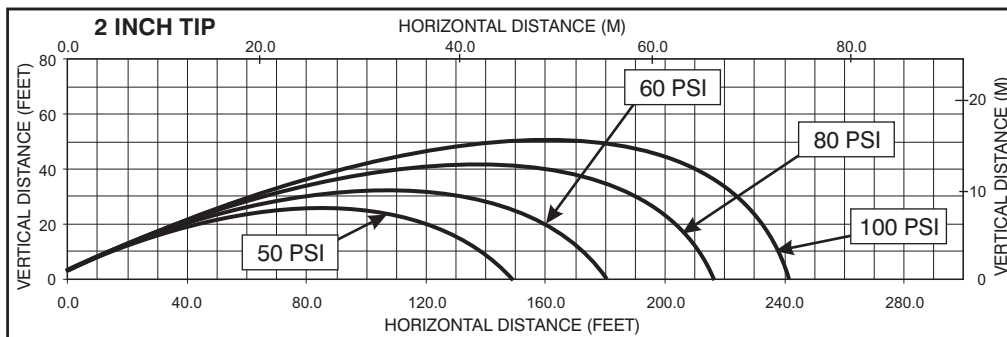

Fig 6.4.1C Stacked Tip Stream Trajectory Graphs

This graph is approximate only.  
 Critical applications should be tested in actual conditions to verify adequate reach.

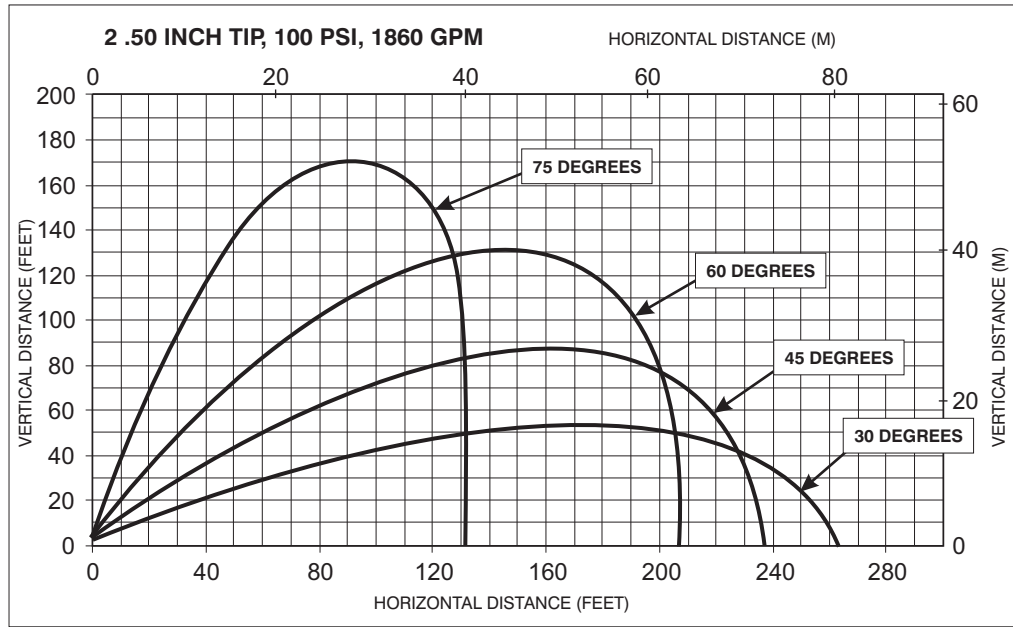

Fig 6.4.1D Effects of Elevation of Trajectory

This graph shows approximately how a moderate wind can affect stream reach. 1 ft = 0.3048 m

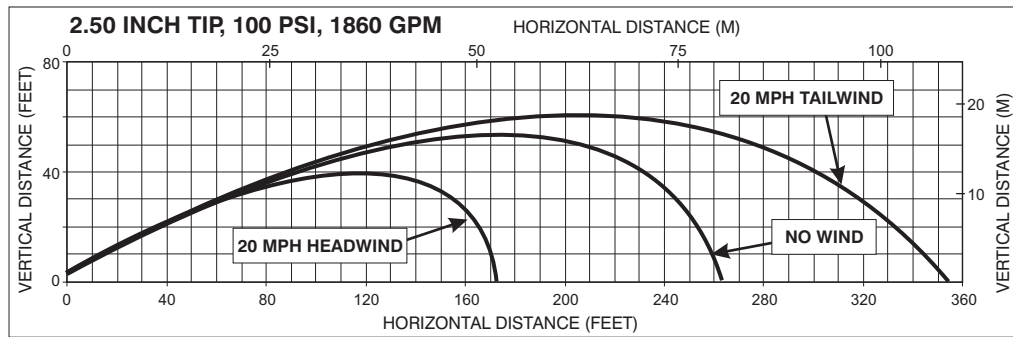
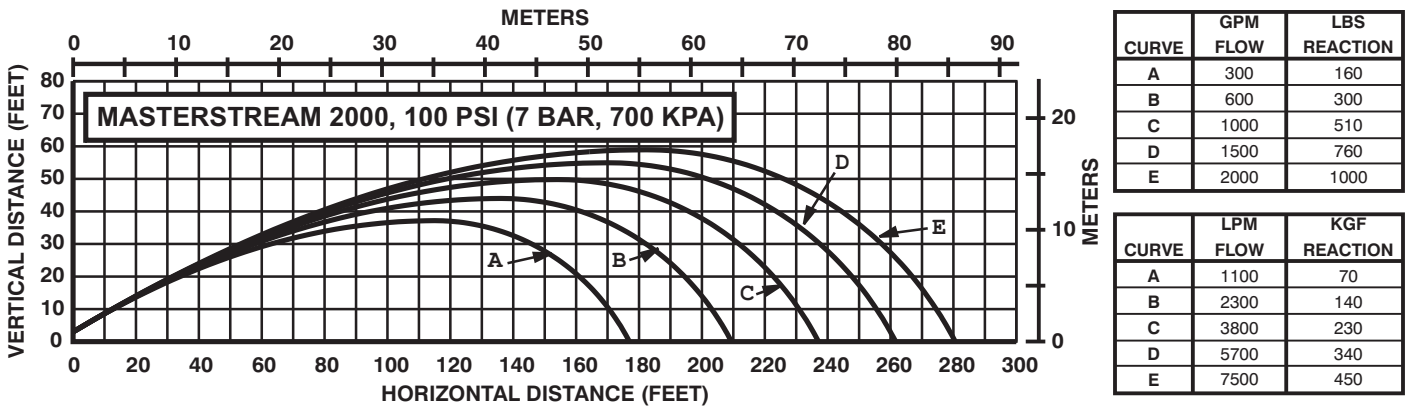

Fig 6.4.1E Effects of wind on reach

### 6.4.2 MASTERSTREAM 2000 NOZZLES

Automatic nozzles maintain a constant pressure by adjusting their orifice to match the available flow. Consult the nozzle manufacturer for maximum flow and pressure range. In all cases do not exceed 2000 gpm (7,600 LPM). TFT's Masterstream 2000 nozzle has a 300-2000 gpm flow range. Masterstream 2000 Nozzle operating instructions (Item Number LIM-030) is available on TFT's website: [www.tft.com](http://www.tft.com)



EXCEL\MISC\IRAN\_MON

### 6.4.3 MONSOON MONITOR FRICTION LOSS

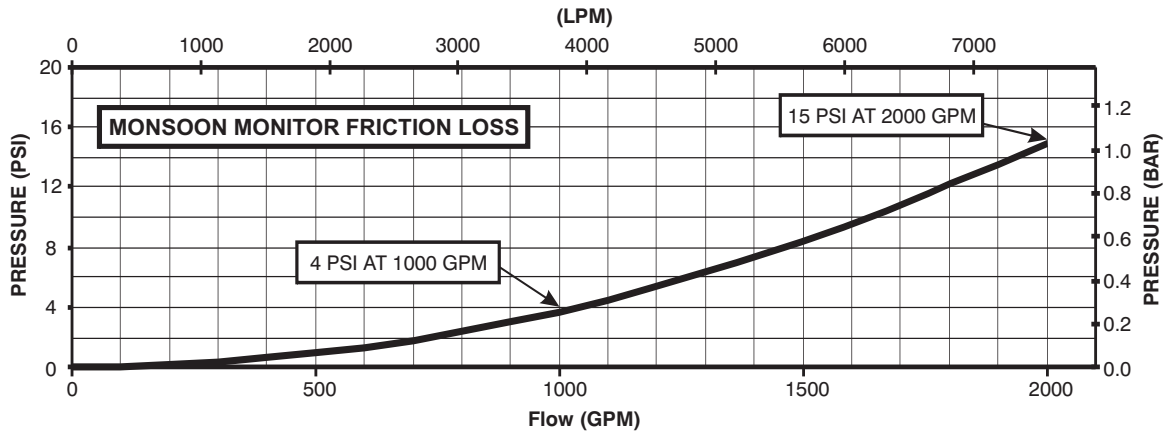

Fig 6.4.3F - Monsoon Monitor Friction Loss

## 6.5 STREAM STRAIGHTENERS

### 6.5.1 STREAM STRAIGHTENERS WITH STACKED TIP NOZZLES

Turbulence though the Monsoon Monitor is very low but stream quality and reach can be improved with the use of the integral stream straightener on the TFT stacked tip nozzle. See figure 6.5.1 for the stacked tip's integral stream straightener friction loss.

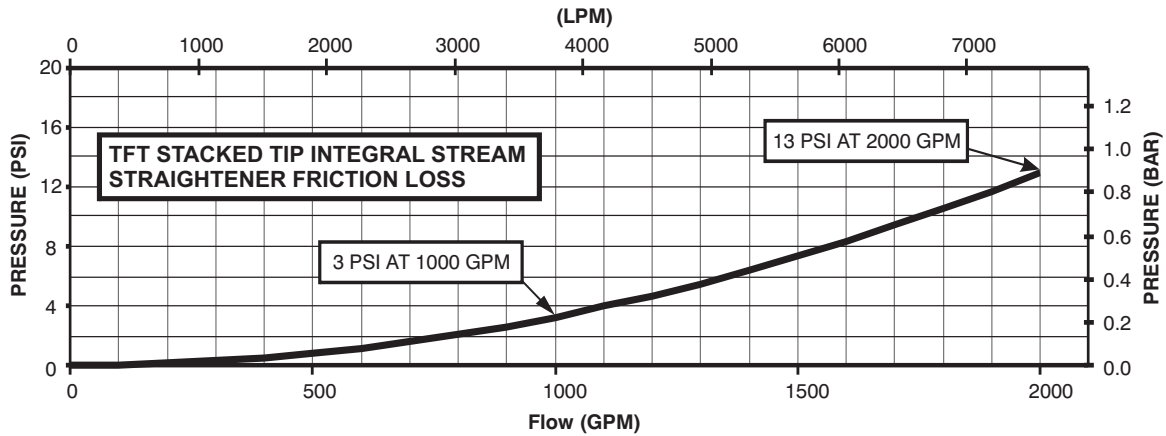
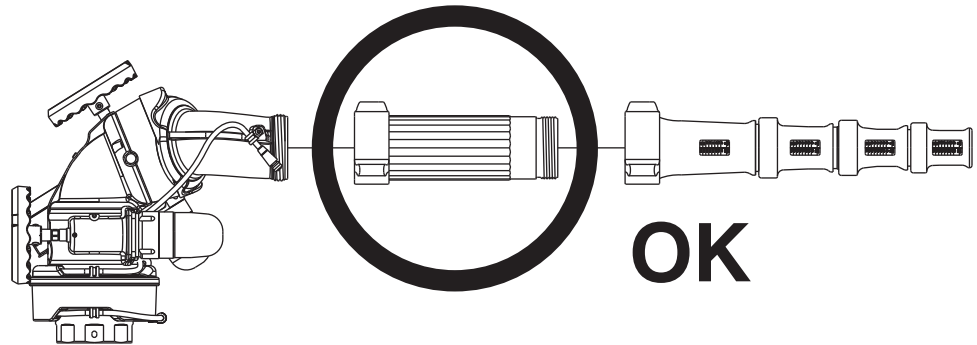
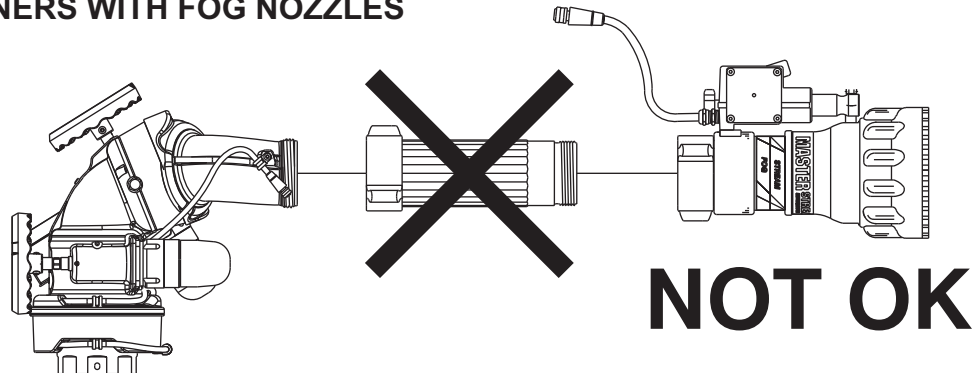

Fig 6.5.1 - TFT Stack Tip Integral Stream Straightener Friction Loss

### 6.5.2 STREAM STRAIGHTENERS WITH FOG NOZZLES

When using a fog nozzle it is recommended that no stream straightener be used since the fog nozzle's flow path generally serves as a stream straightener. Use of a stream straightener with a fog nozzle will increase the stresses on the monitor's gear train and may lead to premature wear.



## 7.0 TROUBLE SHOOTING

SYMPTOM	POSSIBLE CAUSE	REMEDY
Leaks	Debris or damage in seal area	Clean out debris or replace damaged parts
Elevation Binding	Debris or damage to elevation drive parts	Clean out debris or replace damaged parts
	Lack of lubricant	Grease, see section 8.1
Horizontal Rotation Binding	Debris or damage to horizontal drive parts	Clean out debris or replace damaged parts
	Lack of lubricant	Grease, see section 8.1
No Power LED	Polarity reversed	Check wiring and reverse polarity
Power LED On But No Operation	Low voltage due to: - wire gauge too small - wire length too long - poor connection - inadequate apparatus electrical system	Check connections and wiring per section 5
Operation only from monitor operator station. STOW, & OSC LED's on remote station blink slowly when button pressed.	Incorrect wiring	Check blue/white communication wiring
	Bad communication board	Replace communication board in monitor. If problem persists, replace communication board in remote operator station.
Monitor will not operate from any station and STOW & OSC LED's on monitor are on solid.	Bad communication board	Replace communication board in monitor.
Operation only from monitor control station	Communication board code version incompatible	Verify code versions on monitor and all operator stations
One Axis Fails To Operate From Any Control Station	Loose motor wiring connection	Check axis motor connection
	Bad motor control board	Interchange motor control boards and check if problem persists with same axis. If not, replace motor control board.
	Bad motor	Interchange motor control boards. Check if problem persists with same axis. If yes, replace motor.
	Bad membrane switch	Replace membrane switch / operator station
Vertical/Horizontal axis will not speed up	Loose encoder wiring connection	Check axis encoder connection
	Bad motor encoder	Interchange motor control boards. Check if problem persists with same axis. If yes, replace motor.  Remove encoder cover and check for RED light just below disk. If no light, encoder is bad. Replace motor.
Vertical/Horizontal axis runs only in fast speed	Loose encoder wiring connection	Check axis encoder connection
	Bad motor encoder	Interchange motor control boards. Check if problem persists with same axis. If yes, replace motor.  Remove encoder cover and check for RED light just below disk. If no light, encoder is bad. Replace motor.
Vertical/Horizontal axis only runs ~5 seconds and then stops.	Loose encoder wiring connection	Check axis encoder connection.
	Bad motor encoder	Interchange motor control boards. Check if problem persists with same axis. If yes, replace motor.  Remove encoder cover and check for RED light just below disk. If no light, encoder is bad. Replace motor.

## 7.0 TROUBLE SHOOTING (continued)

SYMPTOM	POSSIBLE CAUSE	REMEDY
STOW & OSC LED's on monitor control station blink rapidly when button pressed.	Loose encoder wiring connection.	Check axis encoder connection.
	Bad motor encoder.	Interchange motor control boards. Check if problem persists with same axis. If yes, replace motor.  Remove encoder cover and check for RED light just below disk. If no light, encoder is bad. Replace motor.
Unable to program STOW pattern.	Program enable timer expired.	Cycle power and enter STOW programming mode within 1 minute
Monitor will not operate from Y4E-COMM communication interface box or Ladder/Platform version electronics enclosure.	Incorrect wiring	Check blue & white communication wiring
	Incorrect INPUTS configuration	Verify DIP switch #4 setting matches system wiring (ON for voltage inputs, OFF for ground inputs).

## 8.0 MAINTENANCE AND INSPECTION

The Monsoon Monitor requires little maintenance. The monitor should be kept clean and free of dirt. All controls should be checked for freedom of movement and proper operation before each use. Consult factory for recommended service procedure. Any inoperable or damaged parts should be repaired or replaced immediately.

- Make sure that the monitor's handwheels rotate freely and without binding throughout its range of travel.
- Make sure that there are no leaks when the monitor is flowing water.
- Make sure the nozzle is free of debris.

### 8.1 LUBRICATION CHART

The Monsoon monitor generally should not require greasing. In the event that the operation becomes stiff grease may be applied to the horizontal rotation and elevation worm gears. The grease is applied by removing the plugs at the grease ports and replacing with grease fittings that have 1/4-28 male threads. See figures 8.1A and 8.1B for grease port locations. Use medium viscosity automotive chassis grease. Apply only enough grease to restore normal operation. If normal operation is not restored by greasing than inspect for other causes of stiff operation.

**Note: Do not over pump grease. The monitor's greased areas lead to large chambers that could trap several pounds of grease before becoming visible.**

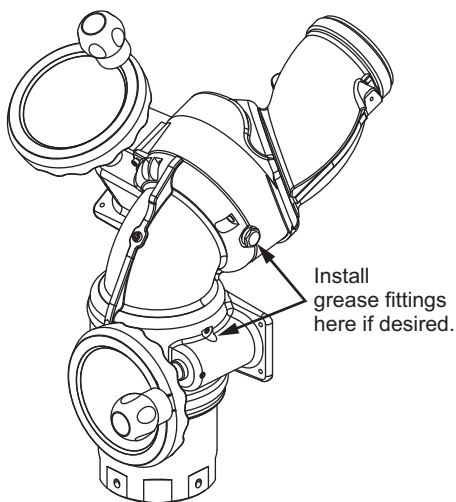

Fig 8.1A  
Location of Grease Port  
for Horizontal Rotation Worm Gear  
and Elevation Joint

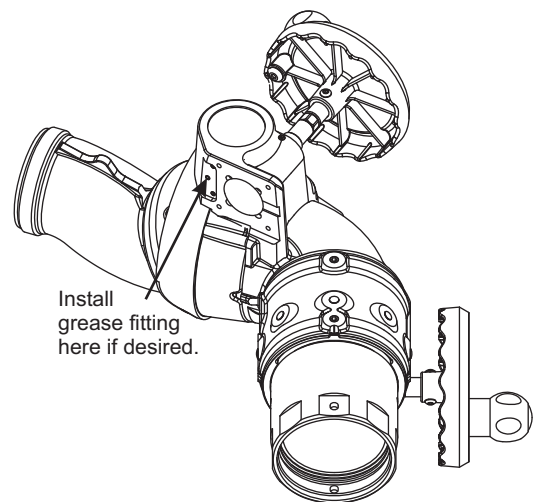
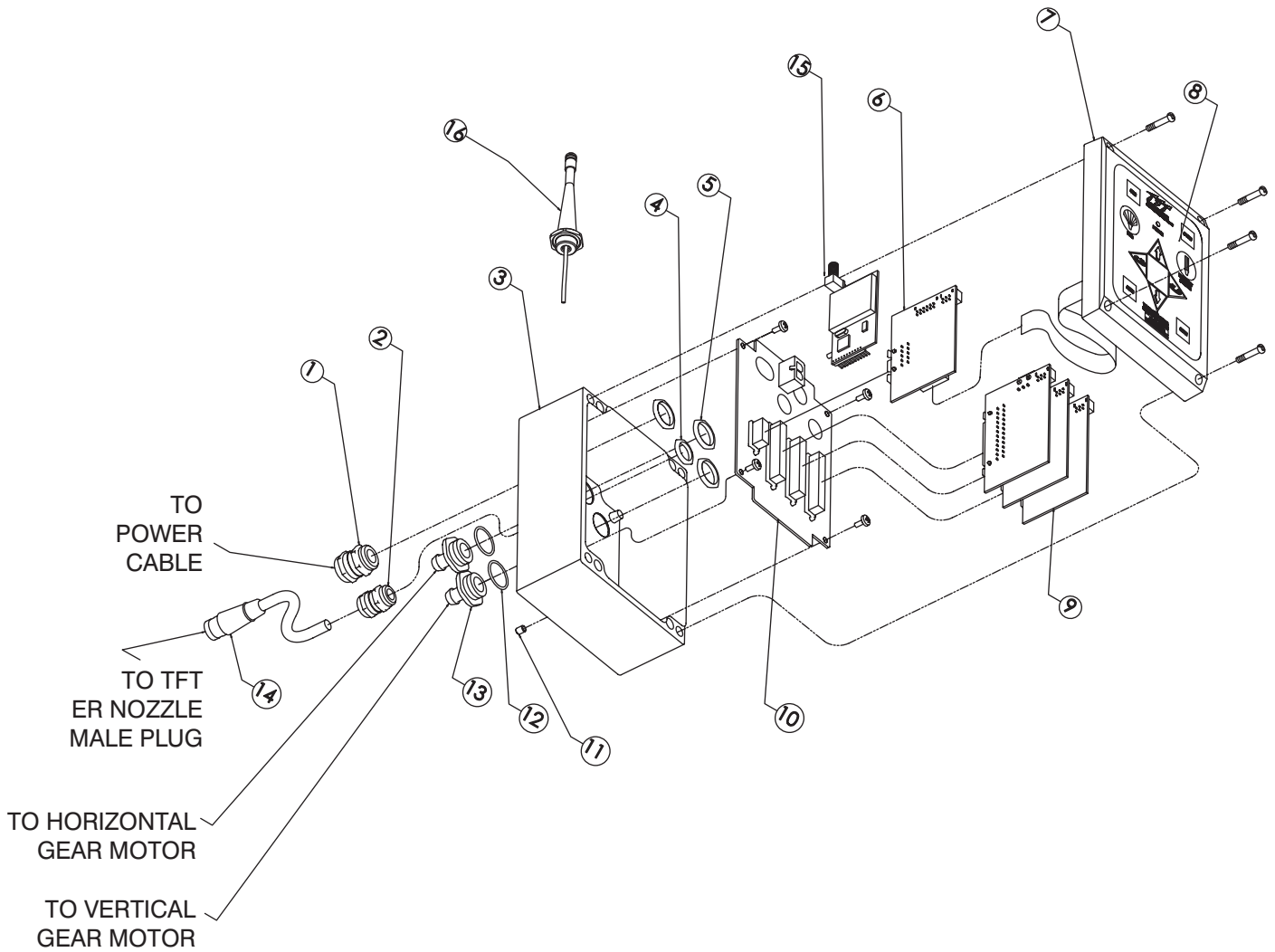

Fig 8.1B  
Location of Grease Port  
for Elevation Worm Gear

### 8.2 PERFORMANCE TESTING

Performance tests should be conducted on the Monsoon Monitor after repairs are made, or any time a problem is reported to verify operation in accordance with Task Force Tips test procedures. Consult the factory for the test procedure that corresponds to the model and serial number of your monitor. Any equipment that fails the test criteria should be removed from service immediately. Equipment can be returned to the factory for service and testing.

## 9.0 MONSOON RC DRAWING & PARTS LIST



#	DESCRIPTION	QTY.		PART NO.
1	CABLE FITTING PG11	1		Y5205
2	CABLE FITTING PG9	1		Y5245
3	ENCLOSURE - BOX	1		Y5115
4	LOCKNUT - PG9	1		Y5246
5	LOCKNUT - PG11	3		Y5206
6	BOARD - COMMUNICATION	1		Y5110-B
7	ENCLOSURE - LID	1		Y5115
8	CONTROL SWITCH PAD	1		Y5700
9	BOARD - MOTOR CONTROL	3		Y5100
10	BOARD - MAIN	1		Y5105
11	V10-32 x 1/4 SET SCREW	1		VT10Y32SS250
12	O-RING-018	2		VO-018
13	CONDUIT HOSE FITTING	2		Y5213
14	FEMALE PLUG - 6 POLE FOR MONSOON RC NOZZLE CONNECTION	10.0" TOTAL LENGTH USED	5.0" EXPOSED CABLE (NOT INCLUDING PLUG)	Y5475
15	BOARD-OEM 900 MHZ RF MODULE (included with part YE-RF-900)	1		Y5710
16	ANTENNA W/FITTING	1		Y5881

# 9.0 MONSOON DRAWING & PARTS LIST

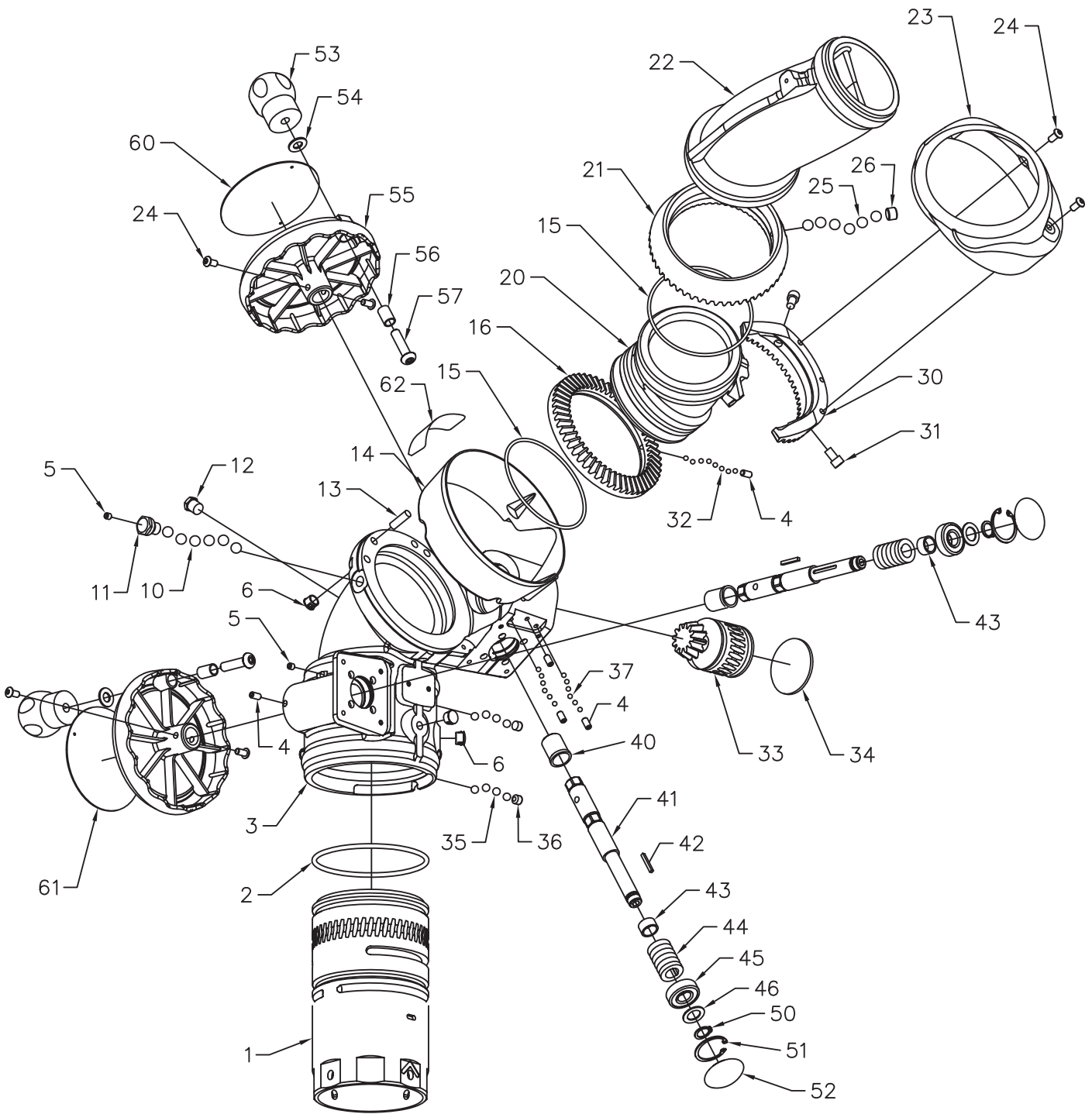

Fig 9.0B  
Monsoon Mechanical Parts  
Exploded View



#	DESCRIPTION	QTY	PART #
1	BASE CODE-RPF 4" -ALUMINUM	1	Y4400A
	BASE CODE-RLF 3" -ALUMINUM		Y4405A
2	O-RING -350 4 5/8 ID 3/16 C/S	1	VO-350
3	LOWER SEGMENT -ALUMINUM	1	Y4110A
4	1/4-28 X 1/2 SOCKET SET SCREW CUP POINT	5	VT25-28SS500
5	1/4-28 X 1/4 SOCKET SET SCREW	2	VT25-28SS250
6	HEYCO BLACK DOME PLUG #2613	8	VM4124
10	BALL 7/16" TORLON	32	VB437TO
11	BALL PORT PLUG	1	Y4155
12	1/4 NPT PLUG - HEX SOCKET	1	VFSP2M-SS
13	DOWEL PIN .3127+- .0001 DIA 1.00+- .012 LG	1	VP312X1.00
14	LOWER SHROUD	1	Y4130
15	O-RING-245 4-3/8 ID 1/8 C/S	2	VO-245
16	LOWER RING GEAR	1	Y4220
20	MIDDLE SEGMENT -ALUMINUM	1	Y4210A
21	UPPER RING GEAR	1	Y4320
22	UPPER SEGMENT -ALUMINUM	1	Y4310A
23	UPPER SHROUD	1	Y4240
24	1/4-20 X 3/8 BUTTON HEAD CAP SCREW	6	VT25-20BH375
25	BALL 7/16" TORLON	32	VB437TO
26	1/2-20 X 3/8 SOCKET SET SCREW CUP POINT	1	VT50-20SS375
30	HALF RING GEAR	1	Y4230
31	5/16-18 X 1/2 SOCKET HEAD CAP SCREW	2	VT31-18SH500
32	3/16" BALL - TORLON	74	V2120-TORLON
33	PINION	1	Y4120
34	PLUG 2-1/4 MOUNTING HOLE	1	Y4162
35	BALL 5/16" TORLON	49 X 2 RACES	VB.312TO
36	3/8-24 X 5/16 SOCKET SET SCREW CUP POINT	2	VT37-24SS312
37	3/16" BALL - TORLON	36 X 2 RACES	V2120-TORLON
40	HEADED BUSHING	2	Y4141
41	DRIVE SHAFT	2	Y4160
42	KEY; 1/8" X 1.00"	2	X225
43	SPACER	2	Y4150
44	12 DP WORM	2	X220
45	BEARING SKF6202-2RS SEAL BOTH SIDES	2	VM4250
46	WASHER .97 OD X .595 ID X .048 THICK	2	VW97X595-048
50	E-CLIP 5/8" EXTERNAL X .042	2	VR4295
51	SNAP RING	2	VR4220
52	PLUG 1-3/8 MOUNTING HOLE	2	Y4161
53	KNOB - SOFT TOUCH	2	A1512
54	WASHER .812"OD .406"ID .065"THICK	2	VW812X406-65
55	HANDWHEEL	2	X281
56	CRANK BUSHING	2	A1513
57	3/8-16 X 1-1/2 BUTTON HEAD CAP SCREW	2	VT37-16BH1.5
60	HANDWHEEL LABEL; DOWN <-> UP	1	Y4175
61	HANDWHEEL LABEL; RIGHT <-> LEFT	1	Y4170
62	NAME LABEL: MONSOON (MANUAL MODEL)	1	Y4182

# 9.0 MONSOON RC DRAWING & PARTS LIST

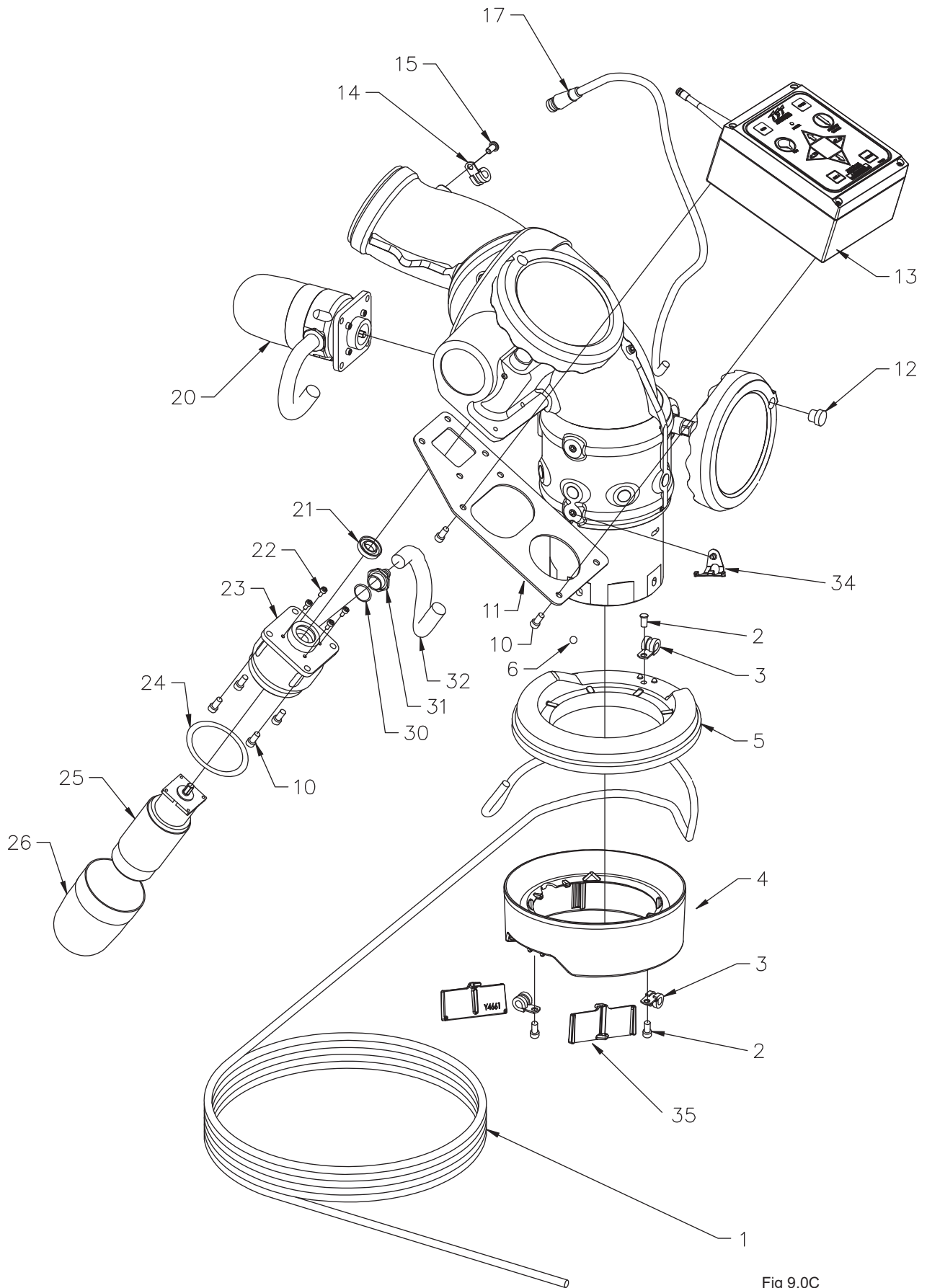

Fig 9.0C  
Monsoon RC  
Exploded View of Electric Parts

#	DESCRIPTION	QTY	PART #
1	CABLE-POWER & COM 2C#14	30 FEET	Y5200
2	1/4-20 X 1/2 BUTTON HEAD CAP SCREW	3	VT25-20BH500
3	.375 OD LOOP CLAMP STAINLESS	3	Y4655
4	LOWER WIRE SKIRT	1	Y4660
5	UPPER WIRE SKIR	1	Y4650
6	BALL 5/16" STAINLESS	1	VB.312
10	1/4-28 X 1/2 SOCKET HEAD CAP SCREW	8	VT25-28SH500
11	CONTROL BOX BRACKET	1	Y4618
11*	CONTROL BOX BRACKET FOR LADDER & PLATFORM	1	Y4619
12	HEYCO BLACK DOME PLUG #2643	2	VM4123
13	MAIN MONITOR CONTROL BOX	1	Y5800
14	.250 OD LOOP CLAMP STAINLESS	2	Y4656
15	10-24 X 3/8 BUTTON HEAD CAP SCREW	1	VT10-24BH375
17	CABLE - 2 POLE FEMALE PLUG	1	Y5280
20	GEAR MOTOR SUBASSEMBLY	1	Y4950
	(#20 Contains Items #21 Thru #32, Except #27))		
21	CUP SEAL 1.0625 X .5625 X 1/4	1	Y4620
22	6-32 X 5/16 LONG SHCS WITH HEAD SEAL	4	VT06S32SH312
23	MOTOR SOCKET	1	Y4615
24	O-RING-038 2-5/8 ID 1/16 C/S	1	VO-038
25	GEAR MOTOR WITH ENCODER	1	Y4610
26	ENCLOSURE	1	Y4616
27	1/4-28X3/4 SOCKET HEAD CAP SCREW	4	VT25-28SH750
30	O-RING-018 3/4 ID 1/16 C/S	1	VO-018
31	CONDUIT FITTING	1	Y5213
32	HOSE - 3/8" ID PUSH-LOK	1 FOOT	Y5250
33	NAME LABEL: MONSOON RC	1	Y4180
34	STOP BALL RETAINER	1	Y4651
35	WIRE SKIRT RETAINER	2	Y4661

## 10.0 WARRANTY

Task Force Tips, Inc., Valparaiso, Indiana 46383-6940 ("TFT") warrants to the original purchaser of its Monsoon and Monsoon RC Monitor ("equipment"), and to anyone to whom it is transferred, that the equipment shall be free from defects in material and workmanship during the five (5) year period from the date of purchase.

TFT's obligation under this warranty is specifically limited to replacing or repairing the equipment (or its parts) which are shown by TFT's examination to be in a defective condition attributable to TFT. To qualify for this limited warranty, the claimant must return the equipment to TFT, at 2800 East Evans Avenue, Valparaiso, Indiana 46383-6940, within a reasonable time after discovery of the defect. TFT will examine the equipment. If TFT determines that there is a defect attributable to it, it will correct the problem within a reasonable time. If the equipment is covered by this limited warranty, TFT will assume the expenses of repair.

If any defect attributable to TFT under this limited warranty cannot be reasonably cured by repair or replacement, TFT may elect to refund the purchase price of the equipment, less reasonable depreciation, in complete discharge of its obligations under this limited warranty. If TFT makes this election, claimant shall return the equipment to TFT free and clear of any liens and encumbrances.

This is a limited warranty. The original purchaser of the equipment, any person to whom it is transferred, and any person who is an intended or unintended beneficiary of the equipment, shall not be entitled to recover from TFT any consequential or incidental damages for injury to person and/or property resulting from any defective equipment manufactured or assembled by TFT. It is agreed and understood that the price stated for the equipment is in part consideration for limiting TFT's liability. Some states do not allow the exclusion or limitation of incidental or consequential damages, so the above may not apply to you.

TFT shall have no obligation under this limited warranty if the equipment is, or has been, misused or neglected (including failure to provide reasonable maintenance) or if there have been accidents to the equipment or if it has been repaired or altered by someone else.

THIS IS A LIMITED EXPRESS WARRANTY ONLY. TFT EXPRESSLY DISCLAIMS WITH RESPECT TO THE EQUIPMENT ALL IMPLIED WARRANTIES OF MERCHANTABILITY AND ALL IMPLIED WARRANTIES OF FITNESS FOR A PARTICULAR PURPOSE. THERE IS NO WARRANTY OF ANY NATURE MADE BY TFT BEYOND THAT STATED IN THE DOCUMENT.



**TASK FORCE TIPS, Inc.**  
MADE IN USA • [www.tft.com](http://www.tft.com)

2800 E. Evans Ave., Valparaiso, IN 46383-6940 USA  
800-348-2686 • 219-462-6161 • Fax 219-464-7155