

Attack Wildfires from the Safety of Your Cab . . .



*Tornado Remote
Controlled Monitor*

. . . REALLY !

The remotely controlled Tornado Monitor from Task Force Tips lets your crew manage initial attack operations while never leaving the protection of the fire apparatus cab.

The Tornado integrates a handheld joy stick monitor and valve controller, quick connect fittings, and exclusive water saving Smart Stream nozzle technology.

To learn more about how you can provide maximum performance and safety to limited staff during wildfire operations, contact your local TFT dealer today.



TASK FORCE TIPS
Made in USA • www.tft.com

3701 Innovation Way, Valparaiso, IN 46383-9327 USA
US & CN 800.348.2686 • 1.219.462.6161 • fax 1.219.464.7155



U.S. & Canada **800.348.2686** www.tft.com
24 Hour Service Team: 800.854.6864

TASK FORCE TIPS 3701 INNOVATION WAY, VALPARAISO, IN 46383-9327 MADE IN USA

Tornado RC Monitor

Visit www.tft.com/FE11 to see a complete video overview of the Tornado Remote Control Monitor.



Tornado RC Monitor shown with Max-Force 100 - 500 gpm dual pressure automatic nozzle. MD-ERP-12A



Remote Controlled Monitor

The Tornado RC is very compact, yet it has a large 2-¼ inch waterway, capable of flowing up to 500 gpm, making it the ideal bumper turret. Waterway with turning vane has only 19 psi (1.3 bar) friction loss at 500 gpm (1900 l/min). Elevation range is 90° above horizontal to 45° below. Field changeable elevation travel stops at 45° above and 20° below horizontal. Horizontal travel is 370° (185° either side of a center position). Field changeable horizontal travel stops to give 180° (90° either side of a center position). Designed for 12 VDC or 24 VDC operation, selection is automatic. The Tornado RC comes with a control panel on the monitor for horizontal rotation, elevation, nozzle pattern, programmable PARK and Oscillate. See page 102-103 for additional control stations. The motor control circuits use position encoders and current limiting to protect the drive train at the ends of travel. Unit has waterproof factory installed plug on power wire for easy removal or reinstallation. Knobs for manual override are provided on the horizontal rotation and elevation drive. Electric drives and control box are waterproof. Main waterway made from hardcoat anodized ANSI 356-T6 aluminum. Silver powdercoat finish inside and out. Various inlets are available. Quick connect inlets and outlets allows for quick removal of the Tornado for installations such as bumper mounting, where the monitor must be removed to tilt the cab of the truck. RC Monitor delivered with wireless antenna installed.

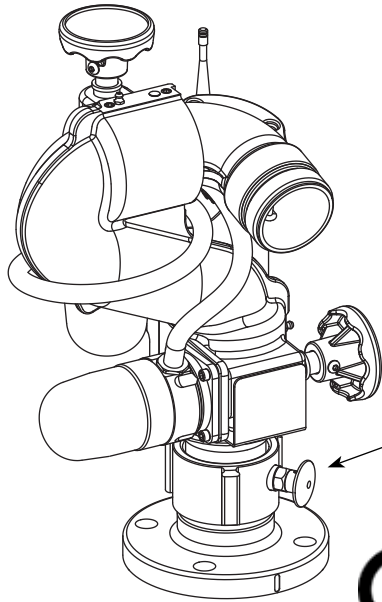

2.5" NH Coupling Quick Connects to various inlet adapters.

Y2-E11A
25.0 lb. (11.4kg)
SAMPLE PART NUMBER
 Specify Inlet and Outlet by number from chart



Monitor Mounted Operator Station

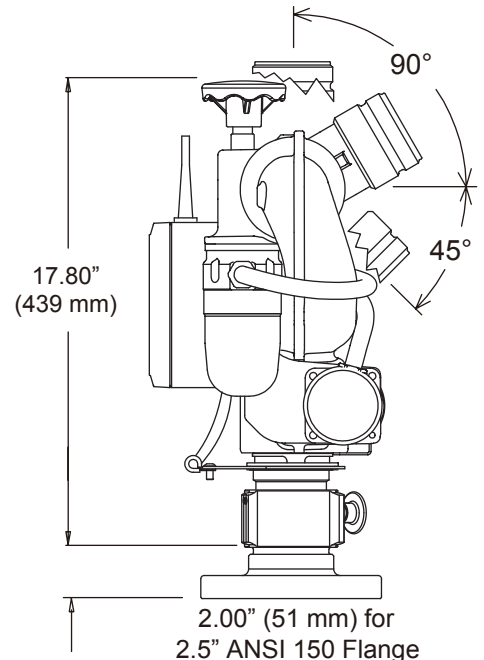
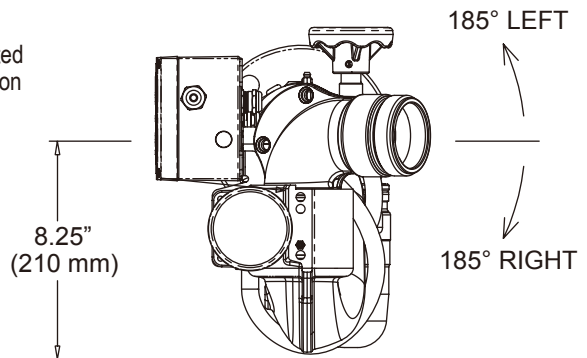

Y2-E

A

Inlet	Outlet
1) 2.5"-7.5 NH Female [§]	1) 2.5"-7.5 NH Male
2) 2.5"-11 BSP Female	2) 2.5"-11 BSP Male
3) 2.0"-11 BSP Female	3) 1.5"-11 BSP Male
5) DN80, PN16	4) 1.5"-9 NH Male
6) 2.5" ANSI 150	8) Special 1.5"
7) 2.5"-8 NPT Female	9) Special 2.5"
8) 2.0"-11.5 NPT Female	
9) 3.0" -8 NPT Female	*Code-RLF fits Extend-A-Gun RC3
0) 3.0" ANSI 150	§No inlet adapter
L) TFT Code-RLF*	