



# MANUAL: TYPHOON & TYPHOON RC MONITOR

See Remote Control (RC) Monitor Electrical Controls Supplemental Instructions For Use With Typhoon RC Models

## INSTRUCTIONS FOR INSTALLATION, SAFE OPERATION AND MAINTENANCE

**⚠ DANGER**

Read instruction manual before use. Operation of this device without understanding the manual and receiving proper training is a misuse of this equipment. A person who has not read and understood all operating and safety instructions is not qualified to operate the Typhoon or Typhoon RC Monitor.

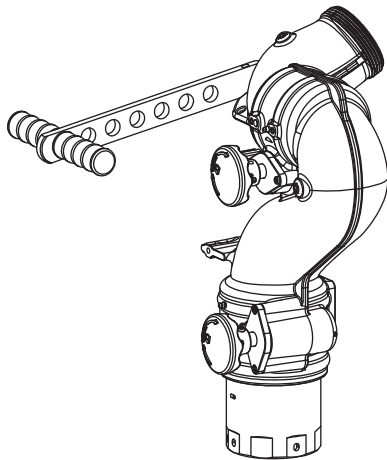

**Typhoon Tiller**

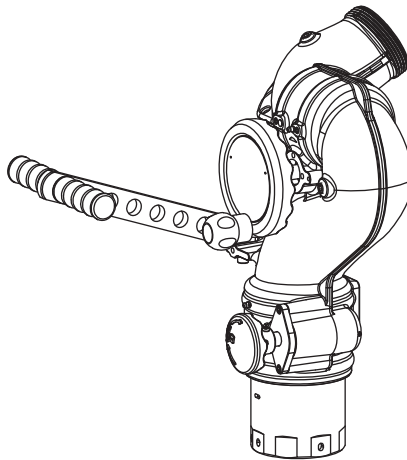

**Typhoon Tiller  
With Handwheel Elevation**

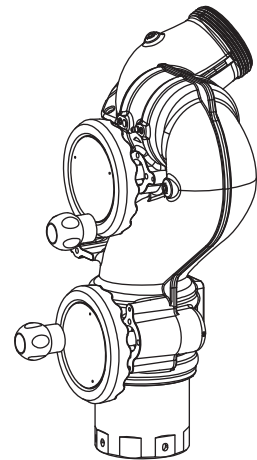

**Typhoon  
Dual Handwheel**

See Section 3.1 for Flow/Pressure  
Operations Envelope

***TYPHOON***

***TYPHOON RC***

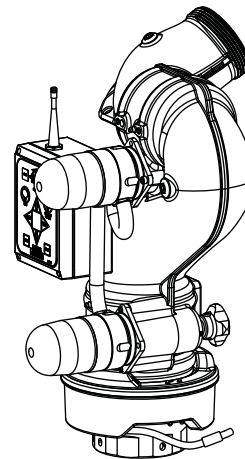

**Typhoon RC**

**TASK FORCE TIPS, INC.**  
MADE IN USA • [www.tft.com](http://www.tft.com)

3701 Innovation Way, Valparaiso, IN 46383-9327 USA  
800-348-2686 • 219-462-6161 • Fax 219-464-7155

## Table Of Contents

<p>1.0 Meaning of Safety Signal Words..... 3</p> <p>2.0 Safety ..... 3</p> <p>3.0 General Information ..... 4-9</p> <p style="padding-left: 20px;">3.1 Mechanical Specifications</p> <p style="padding-left: 20px;">3.2 Part Identification and Models</p> <p style="padding-left: 20px;">3.3 Inlets and Outlets</p> <p style="padding-left: 20px;">3.4 Overall Dimensions</p> <p>4.0 Installation ..... 9-15</p> <p style="padding-left: 20px;">4.1 Structural Requirements for Monitor Mounting</p> <p style="padding-left: 20px;">4.2 Inlet Mounting and Travel Ranges</p> <p style="padding-left: 40px;">4.2.1 Inlet Fitting of Extend-A-Gun Installation</p> <p style="padding-left: 40px;">4.2.2 Horizontal Rotation Travel Stops</p> <p style="padding-left: 40px;">4.2.3 Elevation Travel Stops</p> <p style="padding-left: 20px;">4.3 Nozzle Installation</p> <p style="padding-left: 20px;">4.4 Pressure Gage Port</p> <p style="padding-left: 20px;">4.5 Handle Installation Instructions</p> <p style="padding-left: 20px;">4.6 Drain</p> <p>5.0 Operation ..... 15-16</p> <p style="padding-left: 20px;">5.1 Horizontal Rotation Control</p> <p style="padding-left: 20px;">5.2 Elevation Control</p> <p style="padding-left: 20px;">5.3 Tiller Bar Model</p> <p style="padding-left: 20px;">5.4 Recommended Park Position</p> <p style="padding-left: 20px;">5.5 Override Knobs</p> <p>6.0 Flows and Pressures..... 17-20</p>	<p>6.1 Stacked Tips Flow and Reach</p> <p>6.2 Automatic Masterstream Nozzles</p> <p>6.3 Typhoon Monitor Friction Loss</p> <p>6.4 Stream Straighteners</p> <p style="padding-left: 20px;">6.4.1 Stream Straighteners with Stacked Tips</p> <p style="padding-left: 20px;">6.4.2 Stream Straighteners with Fog Nozzles</p> <p>7.0 FM Approval (Factory Mutual)..... 20</p> <p>8.0 Maintenance and Inspection ..... 21</p> <p style="padding-left: 20px;">8.1 Lubrication</p> <p>9.0 Troubleshooting ..... 21</p> <p>10.0 Typhoon Drawings and Parts List ..... 22-27</p> <p style="padding-left: 20px;">10.1 Manual Typhoon Drawing</p> <p style="padding-left: 20px;">10.2 Typhoon RC Drawing</p> <p style="padding-left: 20px;">10.3 Monitor Control Box</p> <p style="padding-left: 20px;">10.4 Motor Subassembly</p> <p>11.0 Warranty ..... Back Cover</p>
---	--



**PERSONAL RESPONSIBILITY CODE**

The member companies of FEMSA that provide emergency response equipment and services want responders to know and understand the following:

1. Firefighting and Emergency Response are inherently dangerous activities requiring proper training in their hazards and the use of extreme caution at all times.
2. It is your responsibility to read and understand any user's instructions, including purpose and limitations, provided with any piece of equipment you may be called upon to use.
3. It is your responsibility to know that you have been properly trained in Firefighting and /or Emergency Response and in the use, precautions, and care of any equipment you may be called upon to use.
4. It is your responsibility to be in proper physical condition and to maintain the personal skill level required to operate any equipment you may be called upon to use.
5. It is your responsibility to know that your equipment is in operable condition and has been maintained in accordance with the manufacturer's instructions.
6. Failure to follow these guidelines may result in death, burns or other severe injury.



Fire and Emergency Manufacturers and Service Association  
P.O. Box 147, Lynnfield, MA 01940 • [www.FEMSA.org](http://www.FEMSA.org)

## 1.0 MEANING OF SAFETY SIGNAL WORDS

A safety related message is identified by a safety alert symbol and a signal word to indicate the level of risk involved with a particular hazard. Per ANSI standard Z535.6-2006, the definitions of the four signal words are as follows:



**DANGER** indicates a hazardous situation which, if not avoided, will result in death or serious injury.



**WARNING** indicates a hazardous situation which, if not avoided, could result in death or serious injury.



**CAUTION** indicates a potentially hazardous situation which, if not avoided, may result in minor or moderate injury.



**NOTICE** is used to address practices not related to personal injury.

## 2.0 SAFETY

The operation of this monitor can be dangerous. The following must be observed at all times.



**Injury or death may occur by attempting to use a damaged monitor. Before using the monitor inspect it for damage resulting from:**

- Failure to drain monitor followed by exposure to freezing conditions
- Exposure of monitor to temperatures in excess of 160 degrees F
- Structural damage caused by over-pressurization
- Missing parts, physical abuse, exposure to severe chemicals
- Deformed or cracked flanges damaged as a result of improper installation
  - Excessive bolt torque
  - Wrong tightening sequence



**Injury can result from an inadequately supported monitor. The monitor mount must be capable of supporting 1100 lbs (500 kg) of nozzle reaction force.**



**The stream exiting a monitor is very powerful and capable of causing injury and property damage. Make sure the monitor is securely attached to the base and pointing in a safe direction before water to the monitor is turned on. Use care in directing the stream.**



**The monitor may be damaged if frozen while containing sufficient amounts of water. Such damage may be difficult to detect visually and can lead to possible injury or death. Any time the monitor is subject to possible damage from freezing, it must be hydrostatically tested by qualified personnel before being considered safe for use.**



**The electric Typhoon RC may be remotely operated. The electric drives are current limited but may still produce enough force to cause injury. Keep hands and fingers away from pinch points on the monitor.**



**Do not use the manual override knobs while the electric controls are in operation. The electric drives produce enough torque to cause injury.**



**Maximum flow and pressure is 1500 gpm (5700 l/min) and 200 psi (14 bar). Damage or injury may result if the monitor is operated beyond these limits.**



**On many vehicle installations, the monitor is the highest point on the apparatus. Be sure there is sufficient clearance to safely pass under any doors or overhead obstructions. Always check parked position of the monitor before moving.**

### 3.0 GENERAL INFORMATION

The Typhoon monitor is a 4-inch 1500 gpm maximum monitor. It is available in various manually operated models as well as an electric remote model. The electric remote model is known as the Typhoon RC.

### 3.1 MECHANICAL SPECIFICATIONS

	Manual		Electric	
	US	METRIC	US	METRIC
Weight	26 lbs	12 kg	38 lbs	17 kg
Min. Flow Area 4" Inlet	12.6 in <sup>2</sup>	81.1 cm <sup>2</sup>	12.6 in <sup>2</sup>	81.1 cm <sup>2</sup>
Min. Flow Area 3" Inlet	7.07 in <sup>2</sup>	45.6 cm <sup>2</sup>	7.07 in <sup>2</sup>	45.6 cm <sup>2</sup>
Max Flow	1500 gpm	5700 l/min	1500 gpm	5700 l/min
Max Operating Pressure	200 psi	14 bar	200 psi	14 bar
Materials Used	ANSI A356.0-T6 Aluminum, Stainless, Nylon			
Maximum Torque Elevation			70 ft•lbs	95 n•m
Maximum Torque Horizontal			60 ft•lbs	80 n•m
Speed Elevation			12 deg/sec	
Speed Horizontal			12 deg/sec	

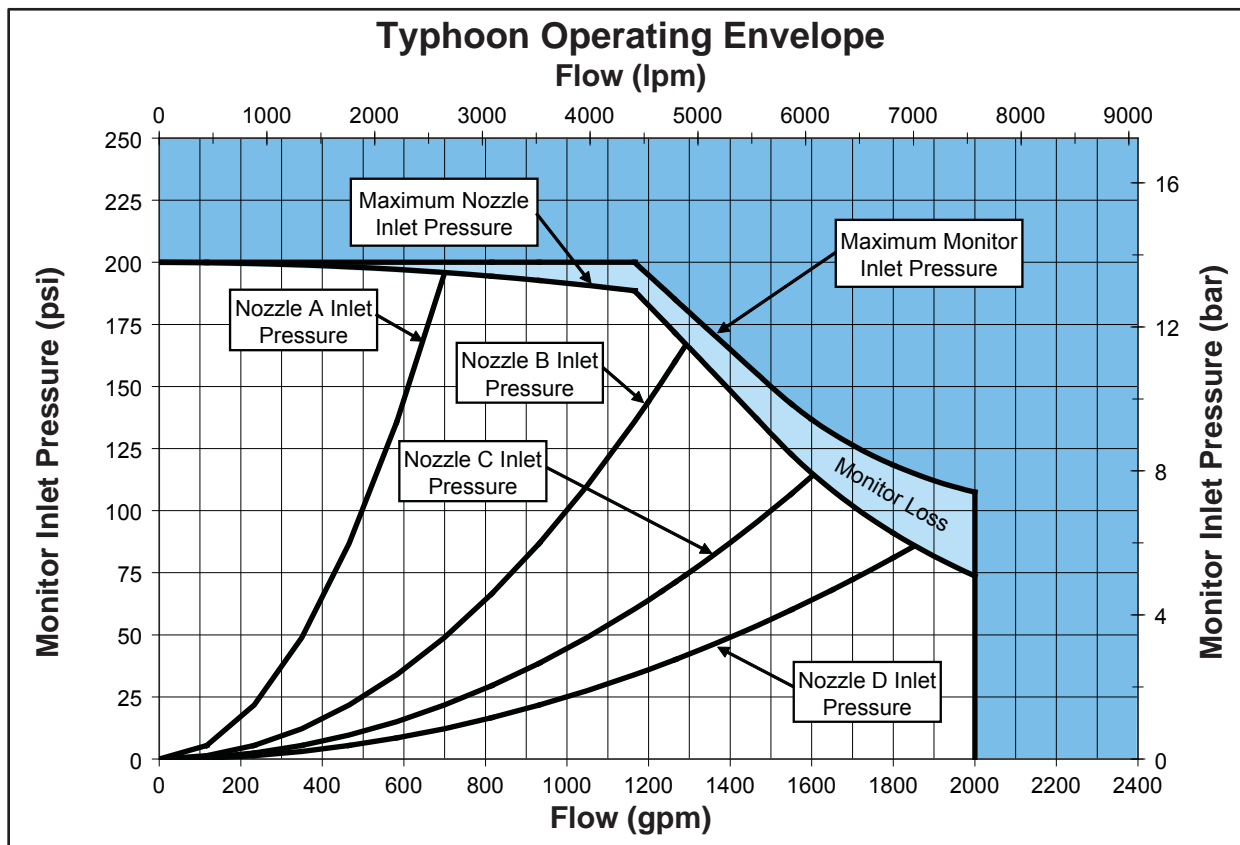

Nozzle A flows 500 gpm (1900 l/min), K factor = 50  
 Nozzle B flows 1000 gpm (3800 l/min), K factor = 100  
 Nozzle C flows 1500 gpm (5700 l/min), K factor = 150  
 Nozzle D flows 2000 gpm (7600 l/min), K factor = 200

Fig.3.1  
 Typhoon Operation Envelope

### 3.2 PART IDENTIFICATION AND MODELS

The Typhoon Monitor comes in manual and electric remote controlled models. Various manual models are available. Electric remote control models are available in a standard model (suitable for on top of pumps), Ladder model, and Platform model. Compared to the standard model, the ladder or platform model has horizontal travel stops factory installed at 90° left and right (180° total). The various models of Typhoon monitors shown in figures 3.2A, 3.2B, 3.2C and 3.2D. The monitor mounted control station on the standard remote controlled model is shown in figure 3.2D.

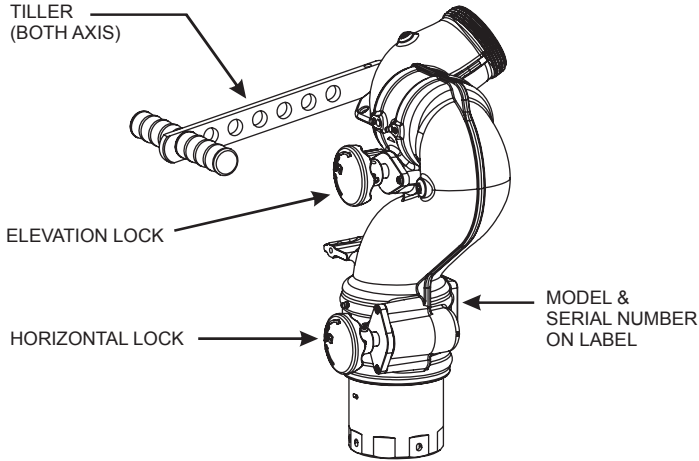

Fig 3.2A  
Tiller Typhoon

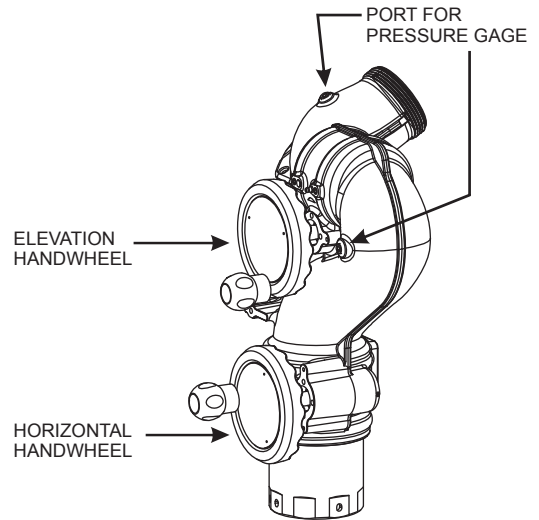

Fig 3.2B  
Dual Handwheel Typhoon

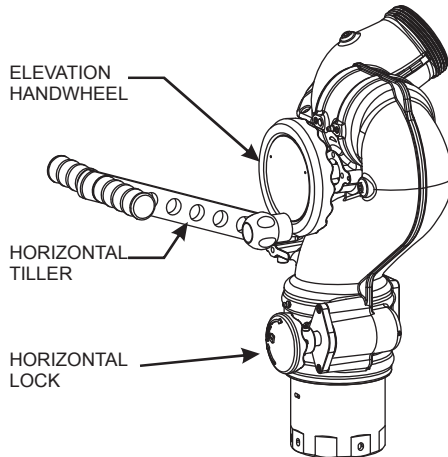

Fig 3.2C  
Tiller and Handwheel Typhoon

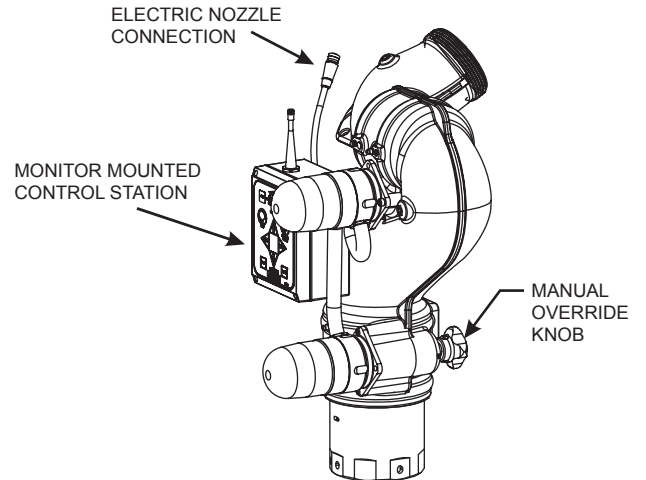
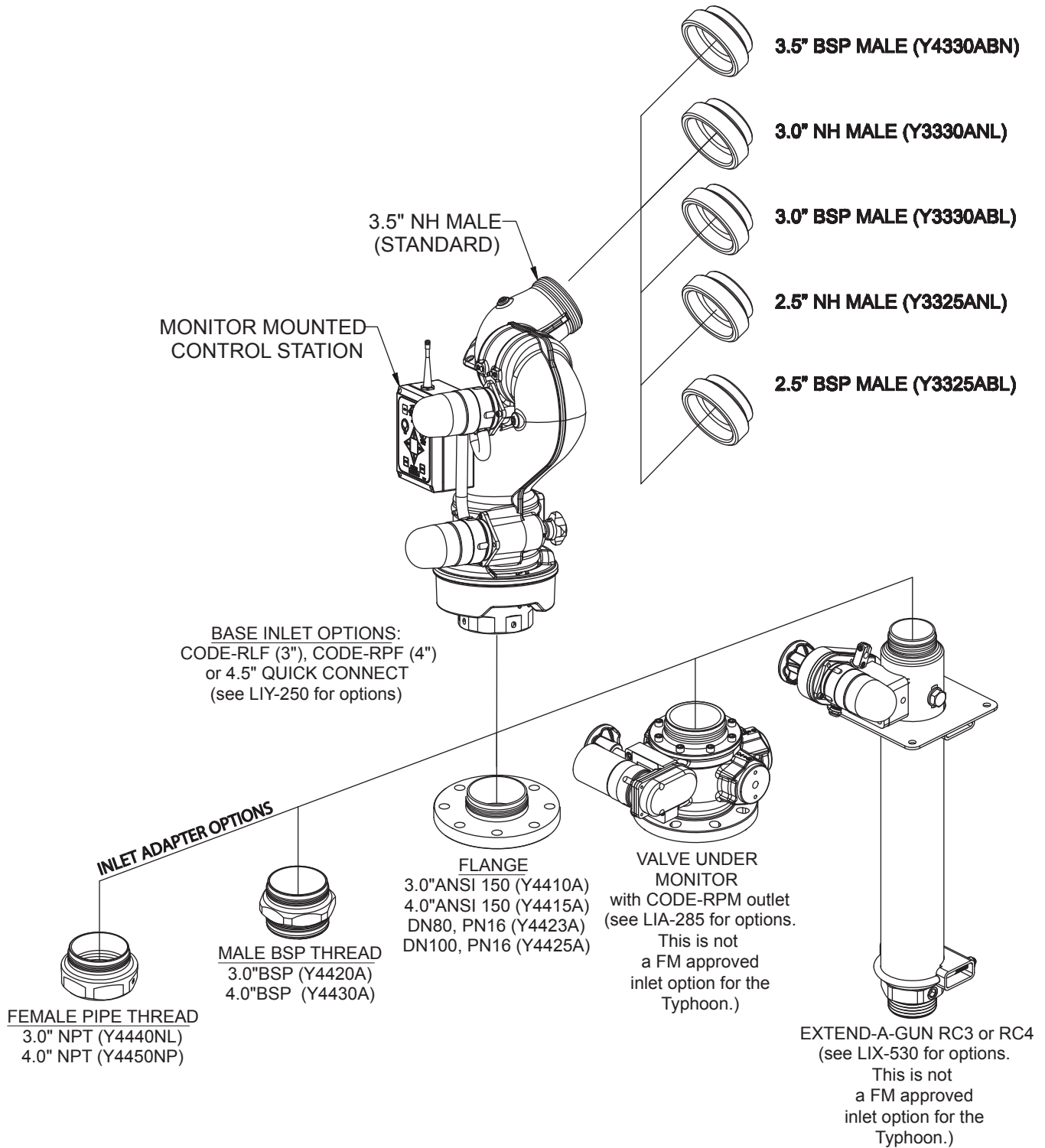

Fig 3.2D  
Typhoon RC

### 3.3 INLETS AND OUTLETS

The standard Typhoon Monitor inlet is CODE-RPF for direct connection to TFT's Extend-A-Gun RC4 (4 inch size). Monitor inlet CODE-RLF is available for direct connection to Extend-A-Gun RC3 (3 inch size). The standard outlet is 3.5"-6 National Hose male. Various other inlet and outlet adapters are available as shown in figure 3.3.



### 3.3 INLETS AND OUTLETS (continued)

FLANGE SIZE	INLET FITTING TYPE	OUTSIDE DIAMETER	THICKNESS	BOLT HOLE CIRCLE	NUMBER OF BOLTS	SIZE OF BOLTS	TORQUE ON BOLTS
Y5-*1*A	3" ANSI 125/150 (metric DN80 PN20)	7.5" (190mm)	.75" (20mm)	6.0" (152.5mm)	"4 4"	5/8" 16mm	76-80 ft-lbf (100-110 Nm)
Y5-*2*A	4" ANSI 150 (metric DN100 PN20)	9.0" (230mm)	.94" (23mm)	7.5" (190.2mm)	"8 8"	5/8" 16mm	76-80 ft-lbf (100-110 Nm)
Y5-*4*A	metric DN80 PN16	200mm	22mm	160mm	8	16mm	100-110 Nm
Y5-*5*A	metric DN100 PN16	220mm	22mm	180mm	8	16mm	100-110 Nm
Y5-*6*A	3" NPT Female	4.40" (111.8mm)	NA	NA	NA	NA	NA
Y5-*7*A	4" NPT Female	5.40" (137.2mm)	NA	NA	NA	NA	NA
Y5-*8*A	3" BSP Male	4.40" (111.8mm)	NA	NA	NA	NA	NA
Y5-*9*A	4" BSP Male	5.40" (137.2mm)	NA	NA	NA	NA	NA
Y5-*L*A	Extend-A-Gun RC3	3.94" (94.6mm)	NA	NA	NA	NA	NA
Y5-*P*A	Extend-A-Gun RC4 or Valve Under Monitor"	4.94" (123.5mm)	NA	NA	NA	NA	NA
Y5-*Q*A	4.5" Quick Connect (without inlet adapter)	6.75" (171.5mm)	NA	NA	NA	NA	NA
Y5-*R*A	4.5" Quick Connect with 4"ANSI 150/DN100 PN16	9.0" (230mm)	.94" (23mm)	7.5 / 7.09" (190/180mm)	8 8	5/8" 16mm	76-80 ft-lbf (100-110 Nm)
Y5-*S*A	4.5" Quick Connect with 4"NPT female inlet adapter	5.40" (137.2mm)	NA	NA	NA	NA	NA
Y5-*T*A	4.5" Quick Connect for Extend-A-Gun RC3	4.25" (108mm)	NA	NA	NA	NA	NA
Y5-*U*A	4.5" Quick Connect for Extend-A-Gun RC4	5.36" (136.1mm)	NA	NA	NA	NA	NA

\* These digits in the model number refer to control type and to exit thread type.

Fig 3.3  
Inlets and Outlets

### 3.4 OVERALL DIMENSIONS

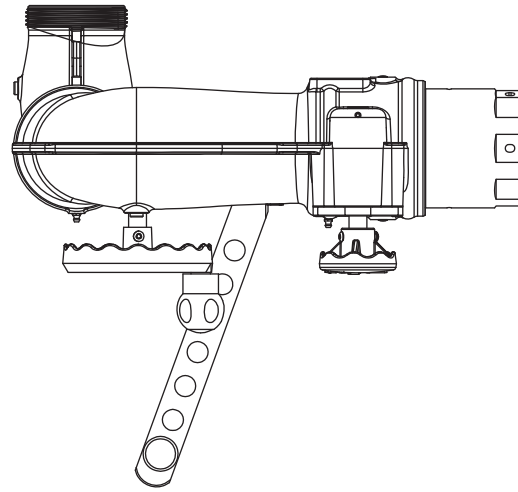
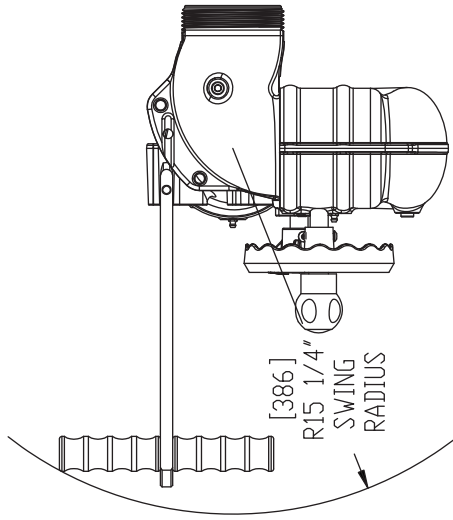

**Manual Tiller Bar Typhoon**

Figure 3.4C

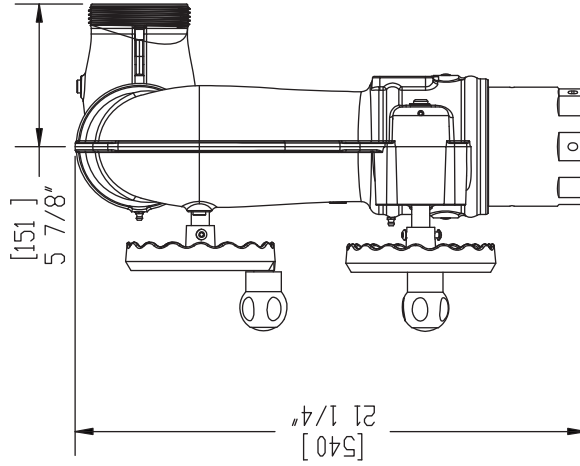
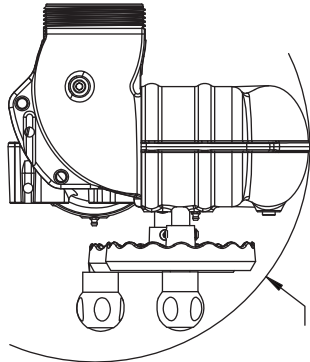

**Dual Handwheel Typhoon**

Figure 3.4B

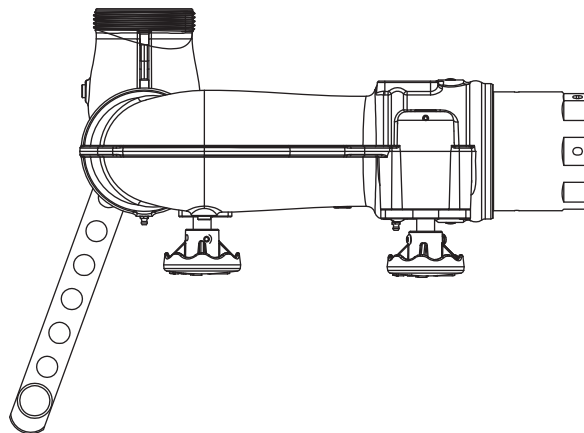
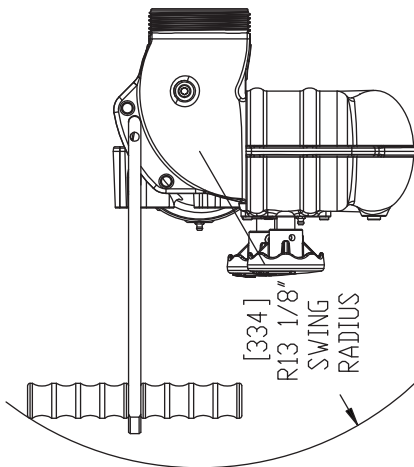

**Tiller Typhoon**

Figure 3.4A



### 3.4 OVERALL DIMENSIONS

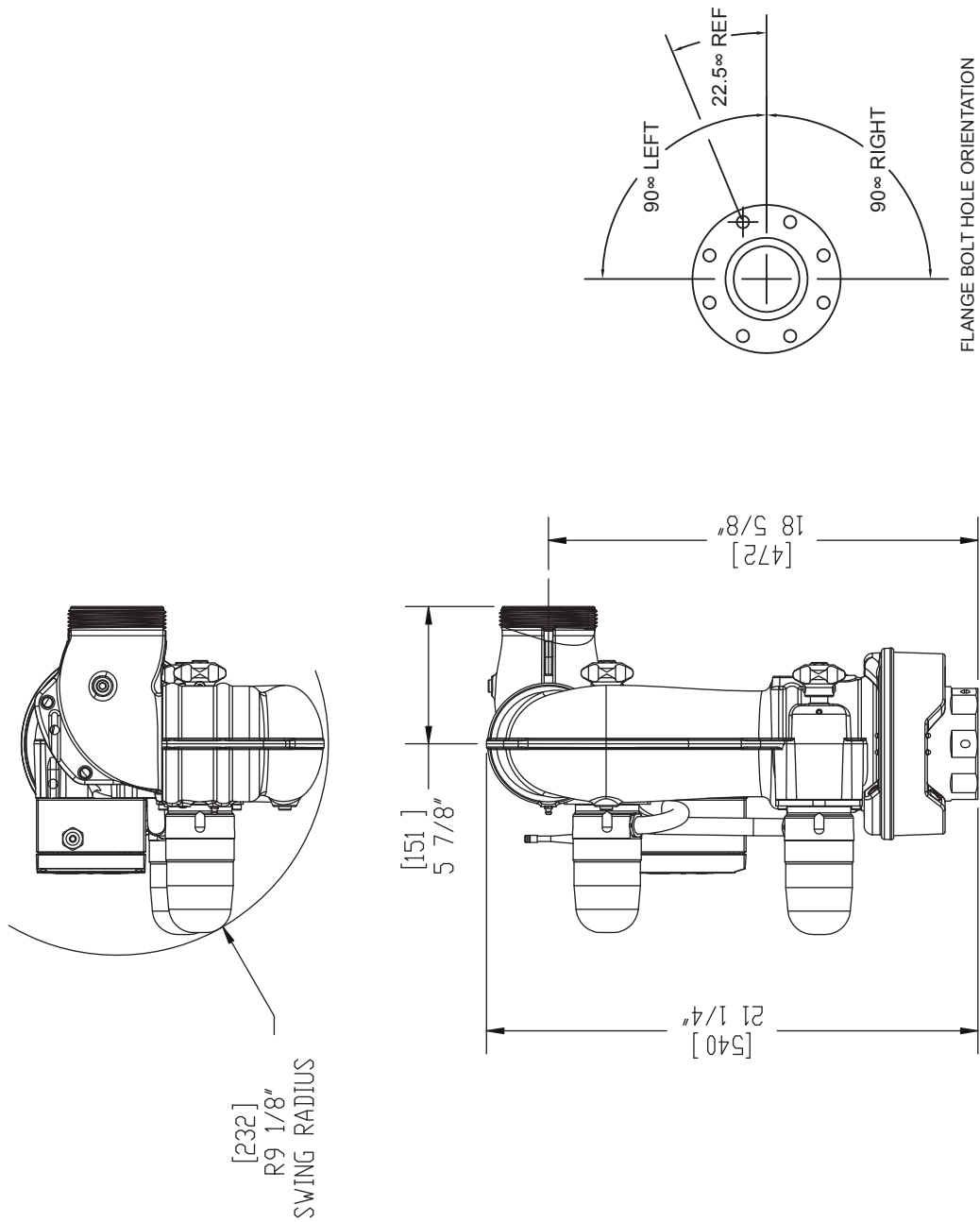

**Typhoon RC**  
Figure 3.4D

### 4.0 INSTALLATION

See Remote Control (RC) Monitor Electrical Controls Supplemental Instructions (LIY-500) For Use With Typhoon RC Models

### 4.1 STRUCTURAL REQUIREMENTS FOR MONITOR MOUNTING

The structure that the Typhoon Monitor is mounted to must withstand the internal pressure of the monitor as well as shear and bending forces due to nozzle reaction. Nozzle reaction can be as high as 1,100 lbs (500 kg) (1500 gpm at 200 psi).

For flanged connections the use of flat flanges without raised faces is recommended. Use a ring gasket as defined in ASME 16.21 or ISO 7483. Tighten flange bolts in an alternating sequence as shown in figure 4.1. Tighten to 76-80 ft-lb (100-110 Newton-Meters).

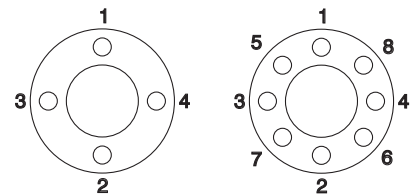

Tighten sequentially each bolt three times.

Fig 4.1 Flange Bolt Tightening Sequence



**Injury can result from an inadequately supported monitor. The monitor mount must be capable of supporting the nozzle reaction force which can be as high as 1100 lbs (500 kg). Flanges and pipe made from plastic are inadequate for monitor mounting and must not be used. This monitor is not recommended for portable use.**

## 4.2 INLET MOUNTING AND TRAVEL RANGES

### 4.2.1 INLET FITTING OR EXTEND-A-GUN INSTALLATION

The Typhoon Monitor is available with various inlet fittings as shown in fig 3.3. When the inlet fittings are used see figure 4.2.1A for the addition to overall height. The Typhoon Monitor also connects directly to TFT's Extend-A-Gun RC3 or RC4. The fittings and Extend-A-Gun RC are attached to the monitor by means of a threaded joint with an o-ring seal. Two different methods of rotational locking between the monitor Base and the Extend-A-Gun Inner Tube exist. One method relies on two ¼-28 Button Head Cap Screws, and the other, newer version, uses a two-piece Clamp that is held together with #10 Cap Screws and Cylindrical nuts. The rotational locking method employed can be identified by the presence or absence of two threaded cross-holes, 180 degrees apart in the threaded portion of the Extend-A-Gun Inner Tube, where the monitor Screws onto the Extend-A-Gun. If ¼-28 Screws are needed, there will be ¼-28 threaded cross-holes in the threaded portion of the Extend-A-Gun Inner Tube. If Clamps are needed, there will be no ¼-28 threaded cross-holes in the threaded portion of the Extend-A-Gun Inner Tube. Once the necessary rotational locking method is determined, install the monitor using one of the following procedures.

#### TWO PIECE CLAMP ROTATIONAL LOCK INSTALLATION INSTRUCTIONS (without tapped holes):

- 1) Assemble Clamps and place loosely on Extend-A-Gun.
  - A) Apply VSA-125 blue Loctite to threads on Cylinder Nut.
  - B) Loosely install Screws, Washers and Cylinder Nuts on Clamp.
  - C) Grooves on heads of Cylinder Nuts indicate alignment of threaded holes.
  - D) Place Clamp assembly over male threads of Extend-A-Gun outlet.
  - E) Heads of Cylinder Nuts must be on top side of Clamps.
- 2) Screw monitor onto Extend-A-Gun RC until threaded joint bottoms out.
  - A) CAUTION: Make sure the Clamps are not tight enough to prevent the monitor Base from bottoming out. The monitor will leak if it does not bottom out in this step.
  - B) DO NOT USE PIPE SEALANT OR LOCTITE ON THE INLET BASE THREADS.  
These threads are sealed with an O-ring. The use of thread locking compounds will make removal difficult.
- 3) Unscrew monitor until the "Straight Ahead Reference Mark" is facing the desired direction.
  - A) Monitor may be unscrewed up to one full turn from the bottomed out position.
  - B) CAUTION: Monitor will leak if unthreaded more than one full rotation from bottomed-out condition.
- 4) Rotate the Clamps to the desired orientation.
  - A) Ensure that Clamp assembly does not interfere with RC monitor Power/Com Cable.
- 5) Tighten each Screw gradually until both are finger tight with approximately equal spacing between opposite ends of Clamps.
- 6) Carefully tighten each Screw one additional turn using a 5/32 hex wrench by alternating to the opposite Screw in half turn increments.
  - A) CAUTION: Over tightening the Screws will damage Screws and Clamps.

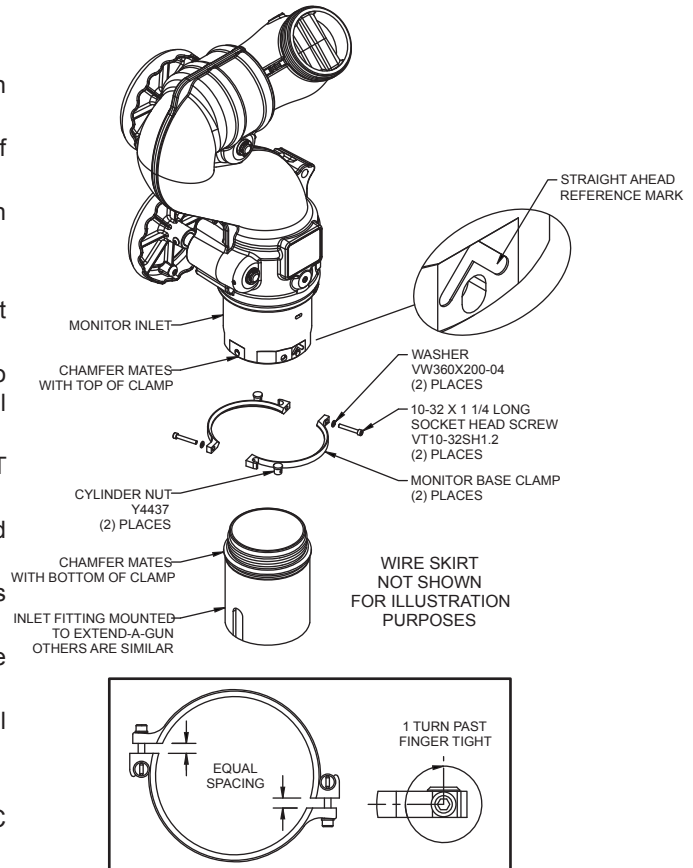

**1/4-28 BUTTON HEAD CAP SCREW ROTATIONAL LOCK INSTALLATION INSTRUCTIONS (tapped holes):**

Once in the proper orientation the threaded joint is locked from rotation by two 1/4-28 button head cap screws as shown in figure 4.2.1B. This makes for easy removal of the monitor since the large threads of the joint are not tightened and do not have any thread locking compounds on them. It is best to install the inlet fitting or Extend-A-Gun RC to the apparatus and then install the monitor to the inlet fitting or Extend-A-Gun RC. This gives more room to install the bolts in the case of flanged fittings. Referring to figures 4.2.1B and 4.2.1C the installation sequence is as follows:

- 1) Install inlet fitting or Extend-A-Gun RC to apparatus.
  - Mount so that 180 degree apart threaded cross holes will give desired direction relative to the "Straight Ahead Reference Mark" when the monitor is installed. See figure 4.2.1B.
- 2) Screw monitor onto inlet fitting or Extend-A-Gun RC until threaded joint bottoms out.
  - Do not use pipe dope or Loctite on the inlet base threads. These threads are sealed with an o-ring. The use of thread locking compounds will make removal difficult.
- 3) Unscrew monitor slightly until a pair of 90 degree apart slots lines up with the 180 degree apart threaded cross holes in the inlet fitting or Extend-A-Gun RC.
  - Orient monitor so that the Straight Ahead Reference Mark is facing the desired direction.
  - Slots will line up with threaded cross holes every 90 degrees of rotation.
  - Monitor may be unscrewed up to one full turn from the bottomed out position.
- 4) Install 1/4-28 by 1/2 long button head cap screws and washers in the two threaded cross holes. Use Loctite #271 on the threads of the button head cap screws. Allow Loctite to fully cure before applying water pressure.

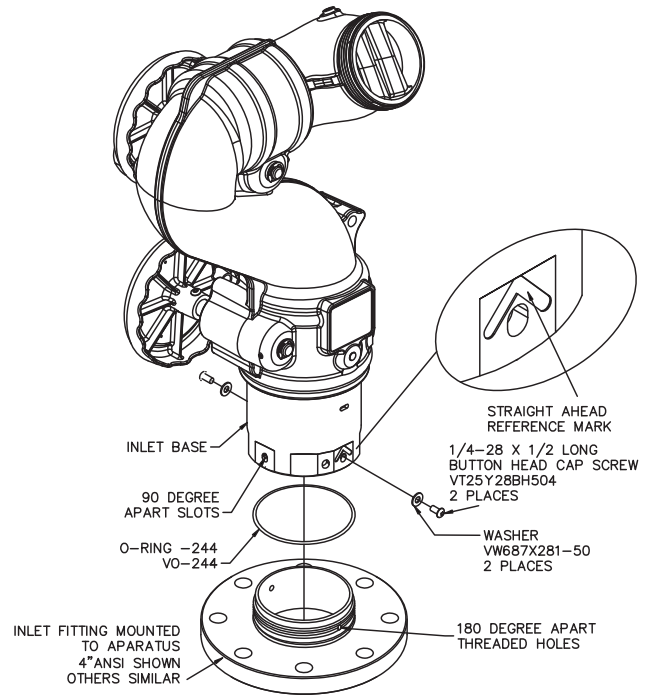
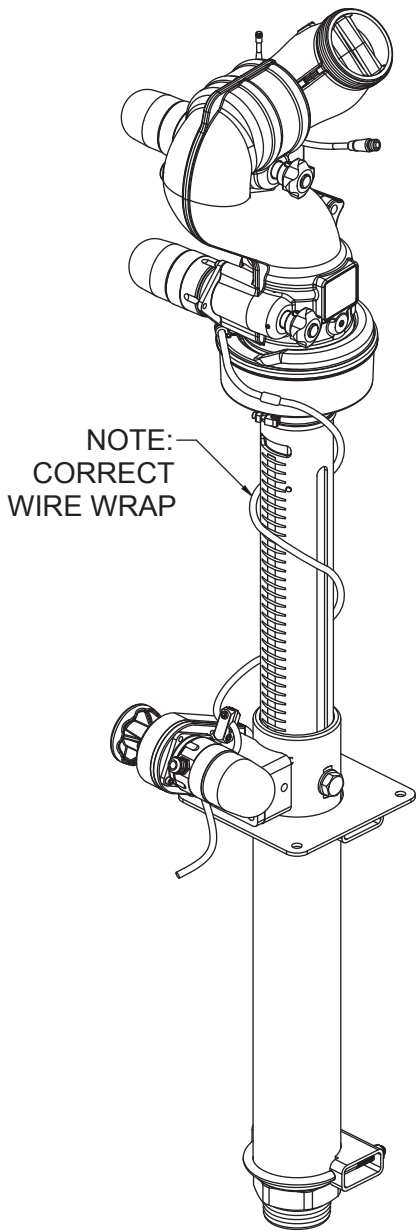

Fig 4.2.1B  
Inlet Fittings Connection

MODEL	INLET FITTING TYPE	ADDITIONAL HEIGHT
Y5-*1*A	"3" ANSI 125/150 (metric DN8 PN20)"	.75" (20mm)
Y5-*2*A	"4" ANSI 150 (metric DN100 PN20)"	.94" (23mm)
Y5-*4*A	metric DN80, PN16	2.80" (22mm)
Y5-*5*A	metric DN100, PN16	2.80" (22mm)
Y5-*6*A	3" NPT Female	2.00" (51mm)
Y5-*7*A	4" NPT Female	1.75" (45mm)
Y5-*8*A	3" BSP Male	2.30" (58mm)
Y5-*9*A	4" BSP Male	2.30" (58mm)
Y5-DQ*A Y5-EQ*A	4.5" Quick Connect	0.63" (16mm) + inlet adapter **
Y5-TQ*A	4.5" Quick Connect	3.38" (86mm) + inlet adapter **
* These digits in the model number refer to control type and to exit thread type.		
** Use height from inlet adapter drawings (YQC series) to determine overall height of monitor with Quick Connect.		

Fig 4.2.1A  
Additional Height for Inlet Fittings



WIRE WRAPPED  
CORRECT

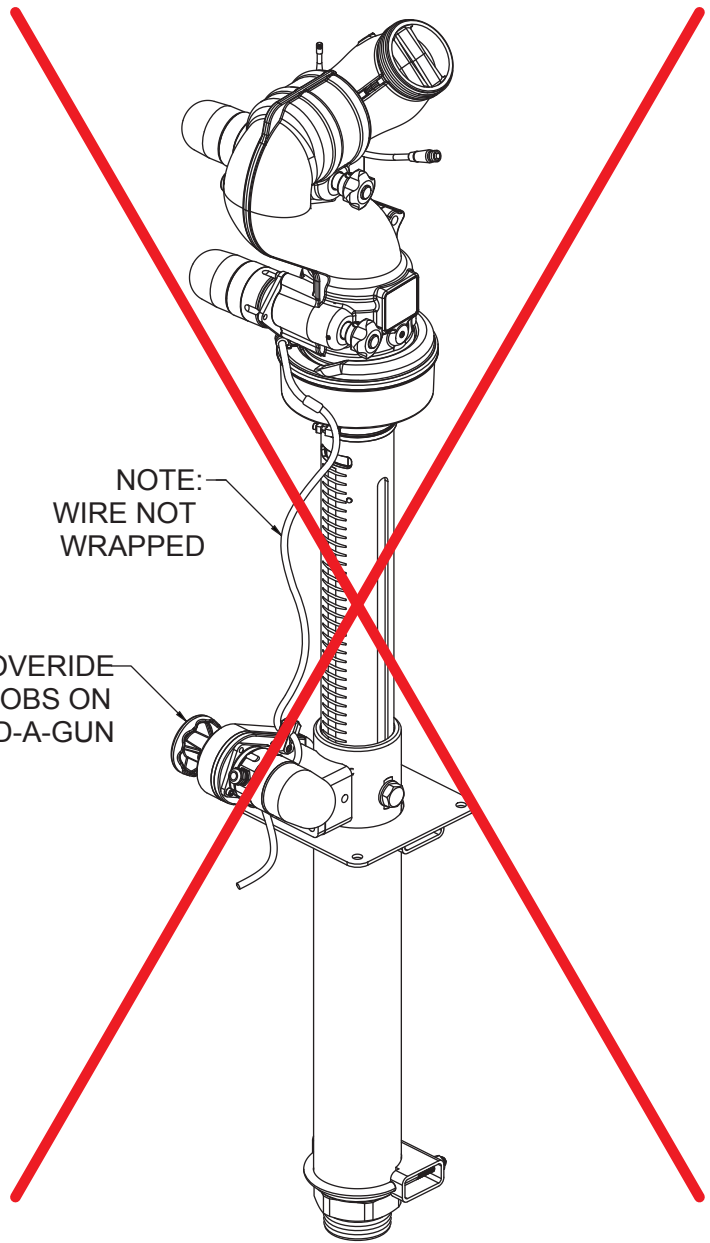

WIRE NOT WRAPPED  
INCORRECT

Fig 4.2.1C Possible Extend-A-Gun RC Mounting Orientations

The Extend-A-Gun manual override knob may be mounted in any of four possible orientations (90 degrees apart) relative to the Straight Ahead Reference Mark on the monitor.

NOTE: Typhoon monitor, for use with Extend-A-Gun RC, comes with the wire installed in a nylon tube. The nylon tubing gives the wire additional stiffness so it better follows as the Extend-A-Gun RC extends or retracts. A fitting is also supplied and is to be used where the nylon tubing and wire pass through the deck.

## 4.2.2 HORIZONTAL ROTATION TRAVEL STOPS

The range of horizontal rotation travel for the manual Typhoon monitor is continuous 360 degrees. The motorized version is limited to 450 degrees total horizontal rotation travel or 225 degrees from either side of a straight ahead position. Horizontal rotation travel stop bolts may be installed in the monitor to limit travel as shown in figures 4.2.2A and 4.2.2B. Note that left and right are relative to the "Straight Ahead Reference Mark" (the Straight Ahead Reference Mark is shown in figures 4.2.1B and 4.2.2A) and refer to the nozzle's discharge direction as seen from an operator's position behind the nozzle. Figures 4.2.2A and 4.2.2B show the range of travel for the various stop bolt locations and give installation notes.

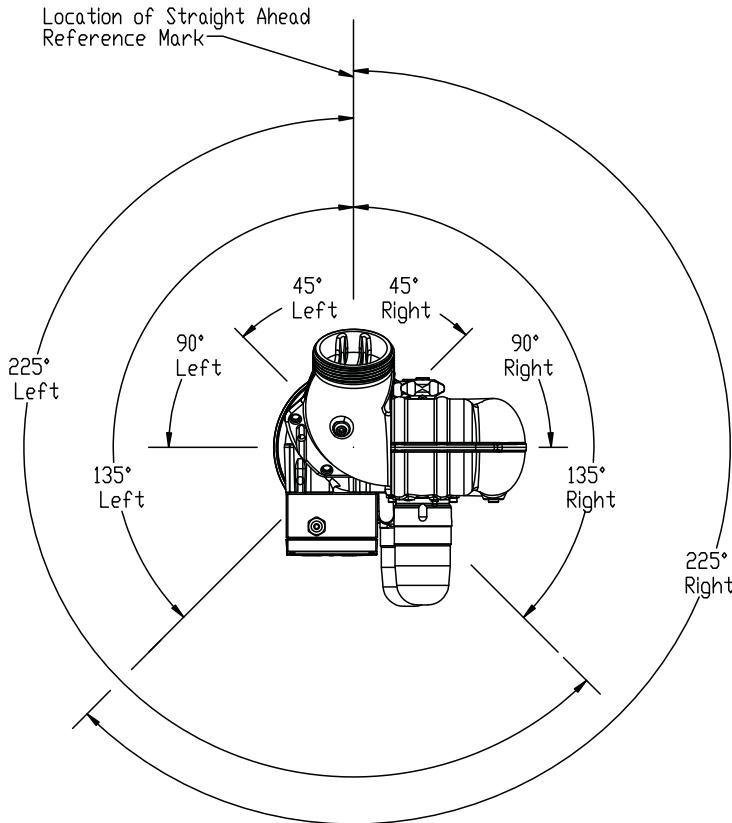

Electric model with no stop bolts installed has 225° left and right horizontal rotation travel limits.

Manual model with no stop bolts installed has continuous 360° horizontal rotation travel.

Fig 4.2.2A  
Horizontal Rotation Travel Limits

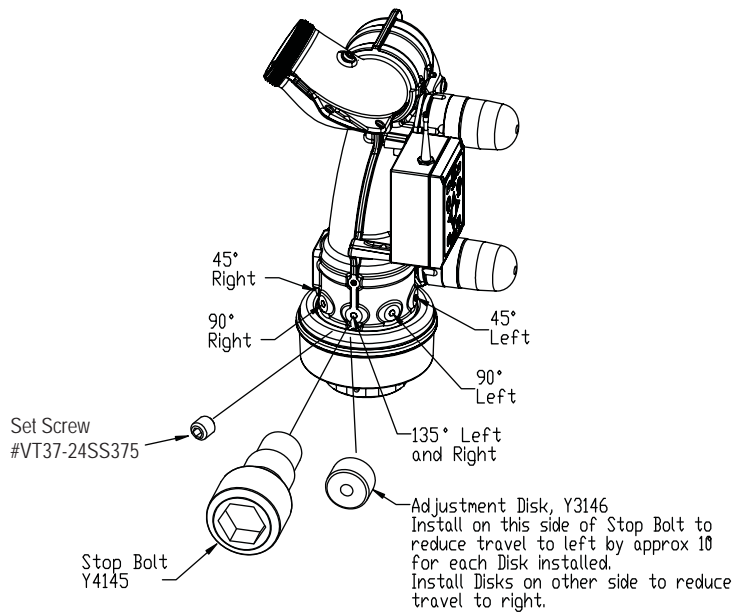

Remove set screw and install Stop Bolt to obtain desired travel limits.

Fig 4.2.2B  
Horizontal Rotation Travel Stop Locations

### 4.2.3 ELEVATION TRAVEL STOPS

The range of elevation travel for the Typhoon Monitor is 45 degrees past vertical to 45 degrees below horizontal. The elevation range may be limited by installing the supplied stop bolts and adjustment disks at the locations shown in figures 4.2.3A and 4.2.3B. Consult factory for other ranges. The figures include installation notes.

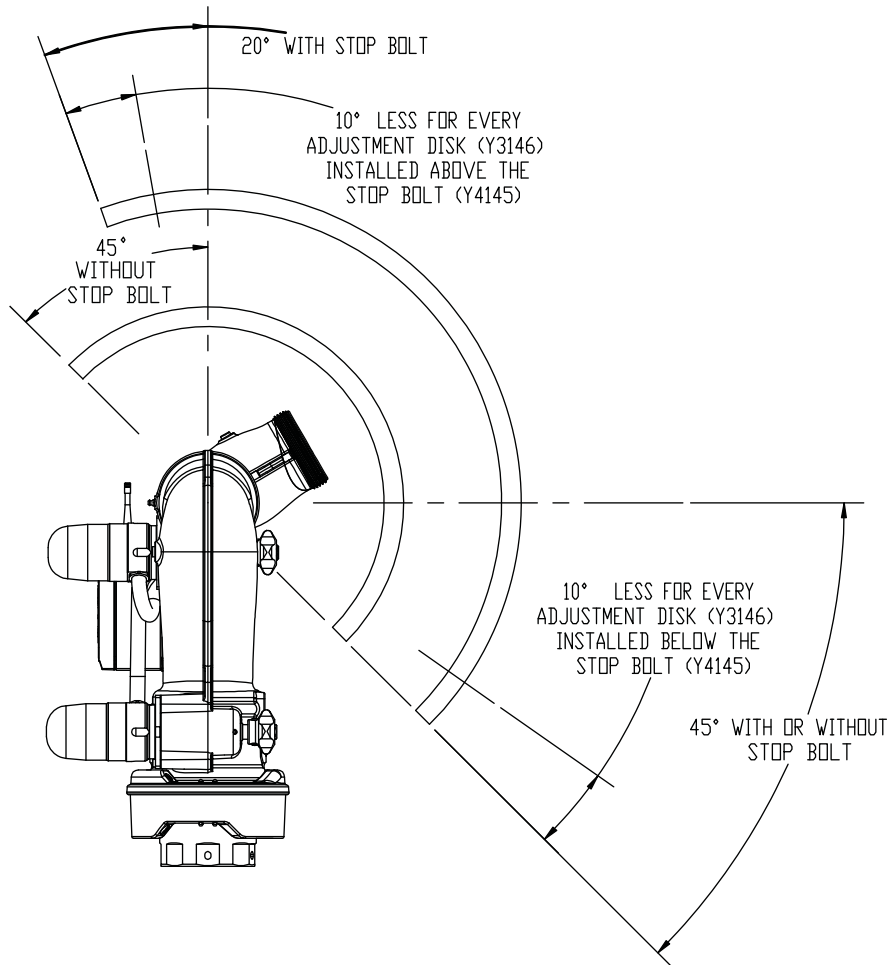

Fig 4.2.3A  
Elevation Travel Limits

Remove set screw and install Stop Bolt to obtain desired travel limits.

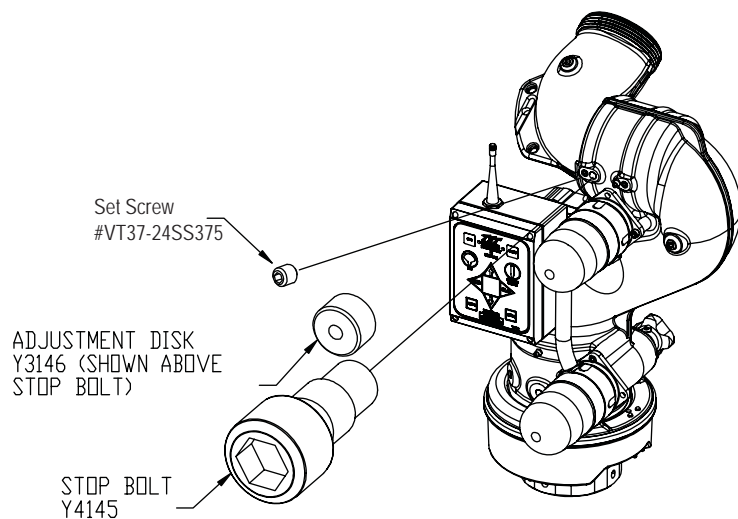

Fig 4.2.3B  
Elevation Travel Stop Locations

### 4.3 NOZZLE INSTALLATION

The nozzle is simply screwed onto the monitor's exit threads. If the nozzle is installed on a Typhoon RC (with electric motors) assure that the nozzle's coupling does not make contact with the horizontal drive motor housing when the monitor is in it's lowest elevation position.

For nozzles with electric pattern control, a cable with a female, waterproof connector is provided at the outlet of the Typhoon RC which attaches directly to TFT's electric Masterstream 1250, 1500 or 2000 nozzle. The cable used is a dual-key, micro type plug assembly. Any other nozzle should have the corresponding male electrical connector installed. Do not cut off the female connector on the monitor. This connector is molded onto the cable and must remain in place to maintain the water tightness of the electrical system.



The nozzle threads must match the threads of the Typhoon monitor in both size and type. Mismatched or damaged threads may cause the nozzle to leak or uncouple under pressure and could cause injury.



Do not connect aluminum to brass or brass to aluminum. Dissimilar metals coupled together can cause galvanic corrosion that will freeze the threaded joint or cause complete loss of thread engagement. If dissimilar metals must be coupled together, the effects of corrosion can be greatly delayed by various coatings on the metal such as powder paint, hard anodizing, or silicone grease.

### 4.4 PRESSURE GAGE PORT

There is a 1/4" NPT female threaded hole on the back of the monitor and the exit elbow. The holes are plugged from the factory. If a pressure gage is desired, unscrew the plug and install the gage using pipe sealant. Make sure the gage does not interfere with operation.

### 4.5 HANDLE INSTALLATION INSTRUCTIONS

The tiller handle is shipped loose from the monitor and must be installed to complete the installation process. When installing the tiller handle, be sure to coat the threads of the mounting screw with the Loctite supplied in the hardware packet.

### 4.6 DRAIN

There is no drain on the Typhoon Monitor itself. A drain valve should be installed on the monitor's inlet piping.

## 5.0 OPERATION

### 5.1 HORIZONTAL ROTATION CONTROL

A handwheel controls the monitor's horizontal rotation direction. Clockwise rotation of the handwheel moves the nozzle to the left and counter-clockwise rotation to the right. Approximately 14 turns of the handwheel will give a 90 degree change in horizontal rotation direction.

### 5.2 ELEVATION CONTROL

A handwheel controls the monitor's elevation direction. Clockwise rotation of the handwheel lowers the elevation and counter-clockwise raises it. About 18 turns of the handwheel will give the complete 135 degree elevation travel range of the monitor.

### 5.3 TILLER BAR MODEL

On the Tiller Bar model the horizontal rotation is changed by pushing or pulling horizontally on the Tiller Handle. Twisting the Rotation Locking Knob clockwise will increase the drag on the lower swivel joint to "lock" the monitor in a particular direction. See figure 5.3 for the Tiller Bar model controls.

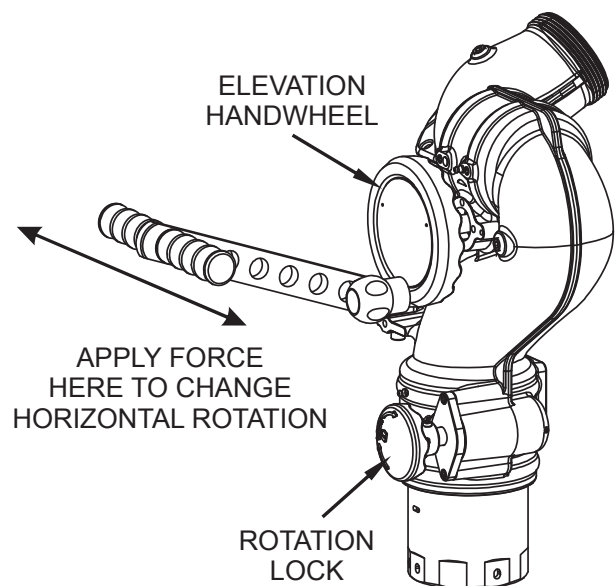

Figure 5.3  
Tiller Bar Model Controls

## **CAUTION**

Injury can result from the monitor changing direction due to an off center nozzle reaction. An off center nozzle reaction may be caused by debris in the nozzle causing an asymmetrical stream. Always keep the rotation lock tight when not rotating the monitor. Always keep one hand on the tiller handle when loosening the locking knob. Where continuous 360 degree rotation of the monitor is not needed it is recommended that the Horizontal Rotation Stop Bolts (see section 4.2.2 for Stop Bolt locations) be installed to reduce any chance of the monitor spinning due to an off center nozzle reaction caused by debris trapped in the nozzle.

### **5.4 RECOMMENDED PARK POSITION**

For truck mounted applications it is recommended that the monitor be parked in a position such that the monitor's nozzle rests against a bracket or support surface. If a support surface is not available, run the elevation against one of its travel stops to take some of the backlash out of the gear drive. This will minimize bouncing of the nozzle when the apparatus is traveling. Always be sure the monitor is properly parked before moving the truck and know the overall height to avoid damage from overhead obstructions such as doors or bridges.

### **5.5 OVERRIDE KNOBS**

In the event of electrical system failure on the monitor or fire truck the Typhoon Monitor is factory supplied with knobs so the monitor may be manually operated. To make the Typhoon RC more compact the manual override knobs may be removed. The drive shafts have a hex so an 11/16" wrench or socket may be used for manual override. The wrenching hexes are shown in figure 5.5.

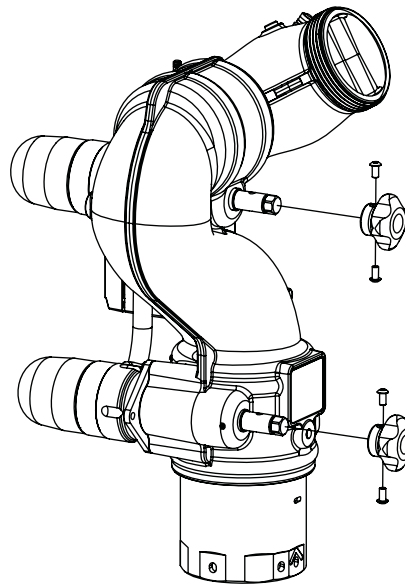

Fig 5.5  
Wrenching Hexes on Drive Shaft



## 6.0 FLOWS AND PRESSURES

### 6.1 STACKED TIPS FLOW AND REACH

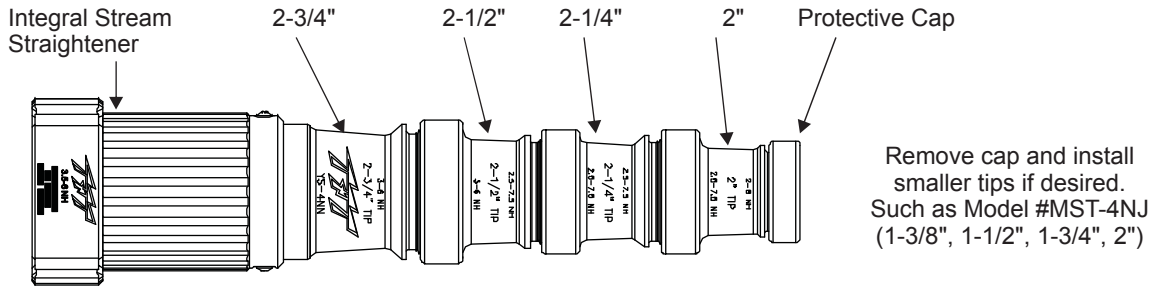

Fig 6.1A  
Stacked Tip Model YST-4NN

Nozzle Diameter (inches)	NOZZLE INLET PRESSURE							
	50 PSI		60 PSI		80 PSI		100 PSI	
	FLOW (GPM)	REACTION (LBS)	FLOW (GPM)	REACTION (LBS)	FLOW (GPM)	REACTION (LBS)	FLOW (GPM)	REACTION (LBS)
2.0	840	310	920	380	1060	500	1190	630
2.25	1080	400	1170	480	1350	640	1500	790
2.5	1310	490	1440	590	—	—	—	—
2.75	1590	590	—	—	—	—	—	—

14.5 psi = 1 bar  
1 gpm = 3.785 l/min

**FLOW EXCEEDS RATING OF TYPHOON MONITOR**

Nozzle Diameter (mm)	NOZZLE INLET PRESSURE							
	3.5 BAR		4.1 BAR		5.5 BAR		7 BAR	
	FLOW (l/min)	REACTION (KG)	FLOW (l/min)	REACTION (KG)	FLOW (l/min)	REACTION (KG)	FLOW (l/min)	REACTION (KG)
50	3180	140	3480	170	4010	230	4500	290
57	4010	180	4430	220	5110	290	5680	360
64	4960	220	5450	270	—	—	—	—
70	6020	270	—	—	—	—	—	—

14.5 psi = 1 bar  
1 gpm = 3.785 l/min

**FLOW EXCEEDS RATING OF TYPHOON MONITOR**

Fig. 6.1B  
Stacked Tips Flow Table

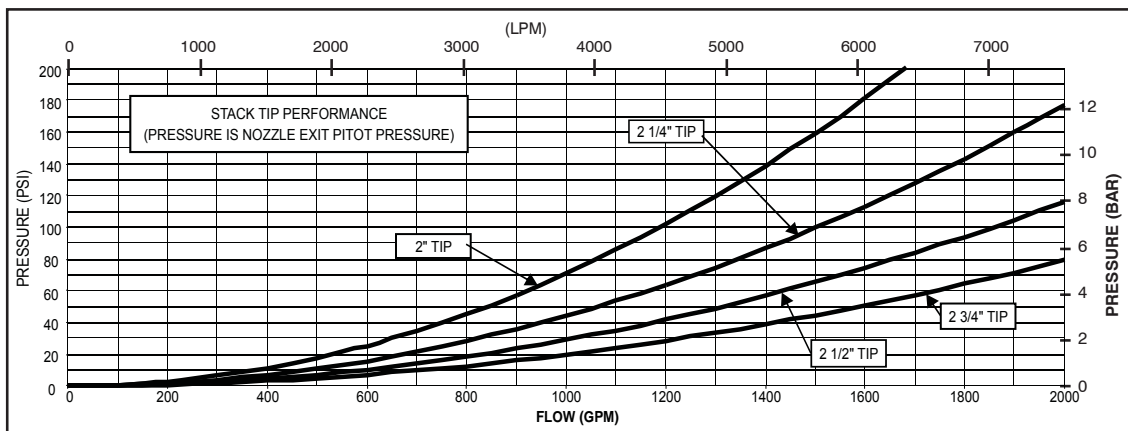

Fig 6.1C  
Stacked Tip Flow Graph

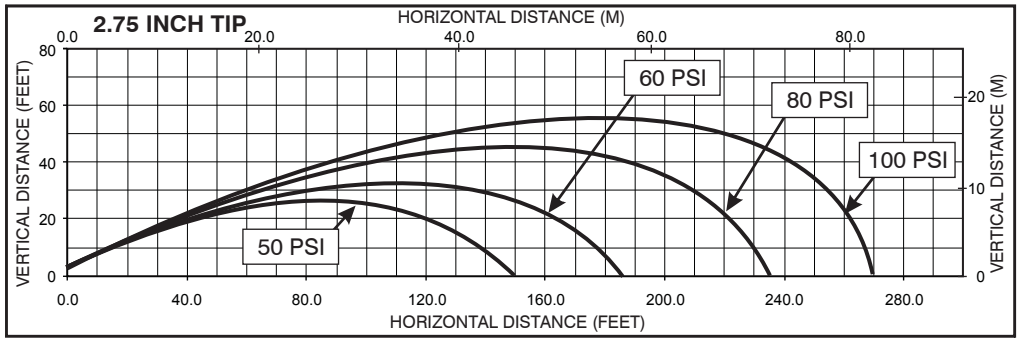
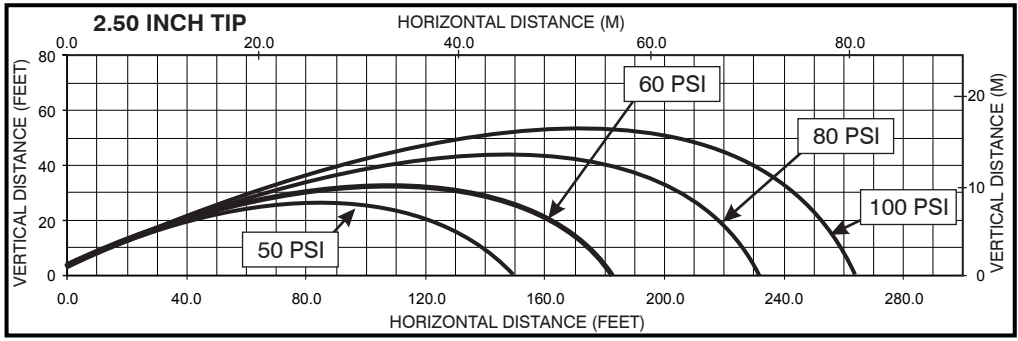
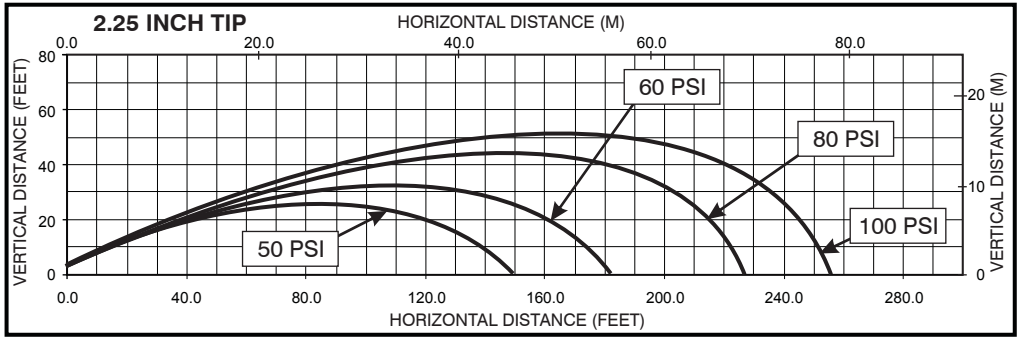
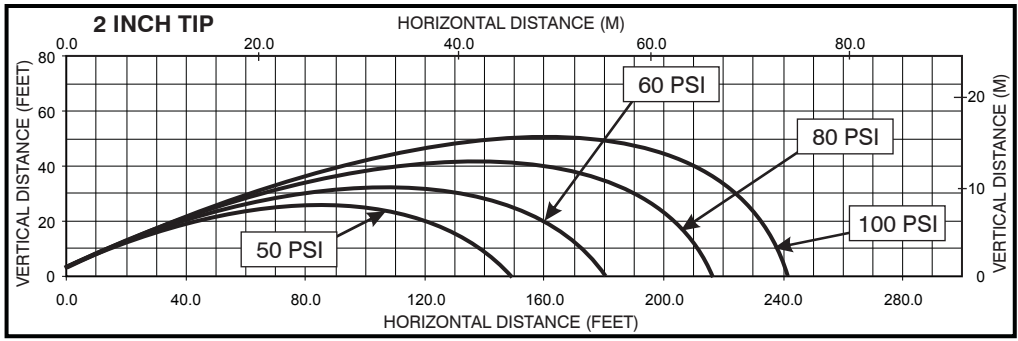

Fig 6.1D  
Stacked Tip Stream Trajectory Graphs

This graph is approximate only. Critical applications should be tested in actual conditions to verify adequate reach.

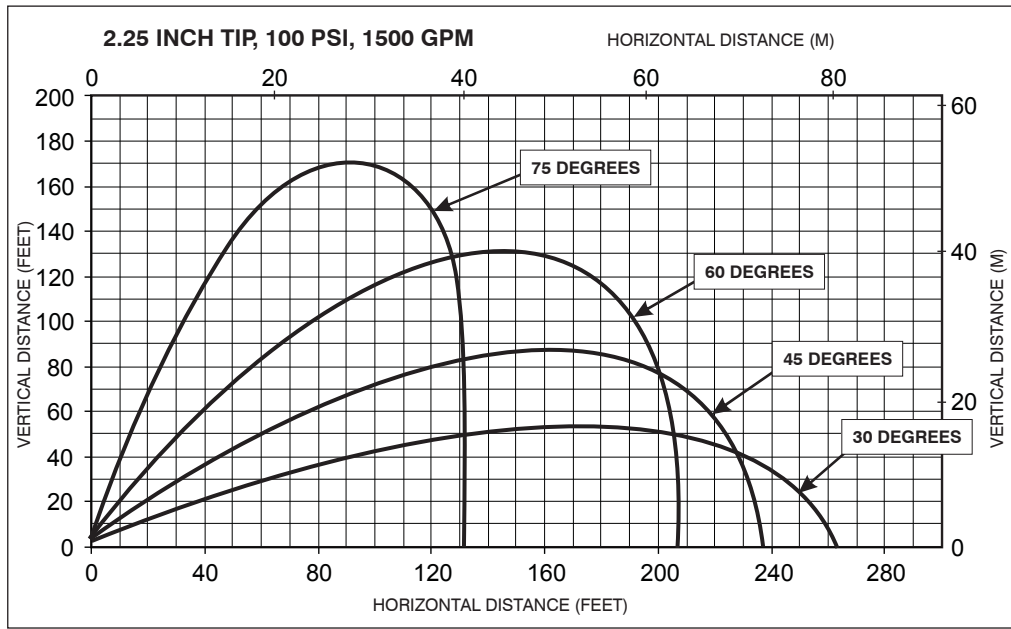

Fig 6.1E  
Effects of Elevator Trajectory

This graph shows approximately how a moderate wind can affect stream reach. 1 ft = 0.3048 m

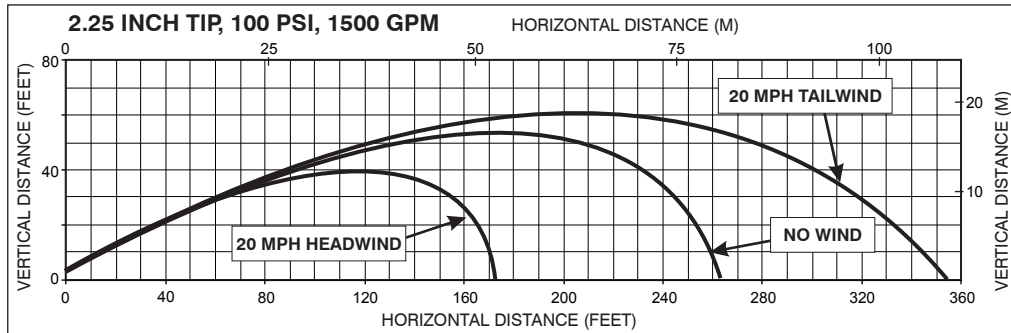

Fig 6.1F  
Effects of Wind on Reach

## 6.2 AUTOMATIC MASTERSTREAM NOZZLES

Automatic nozzles maintain a constant pressure by adjusting their orifice to match the available flow. Consult the nozzle manufacturer for maximum flow and pressure range. In all cases do not exceed 1500 gpm (5,700 LPM). TFT's Masterstream 1500 nozzle has a 300-1500 gpm flow range. Masterstream 1500 Nozzle operating instructions (Item Number LIM-030) is available on TFT's website: [www.tft.com](http://www.tft.com)

## 6.3 TYPHOON MONITOR FRICTION LOSS

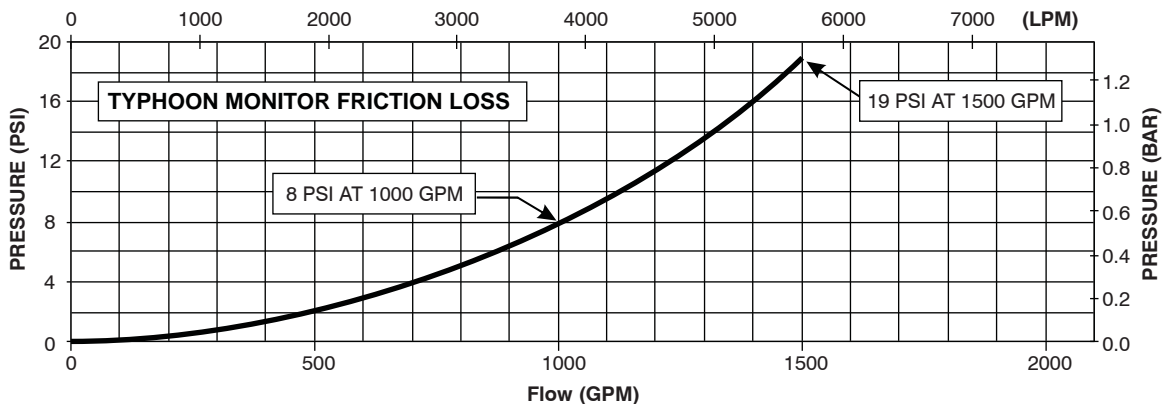

Fig 6.3  
Typhoon Monitor Friction Loss

## 6.4 STREAM STRAIGHTENERS

### 6.4.1 STREAM STRAIGHTENERS WITH STACKED TIPS

Turbulence through the Typhoon Monitor is very low but stream quality and reach can be improved with the use of the integral stream straightener on the TFT stacked tip nozzle. See figure 6.4.1 for the stacked tip's integral stream straightener friction loss.

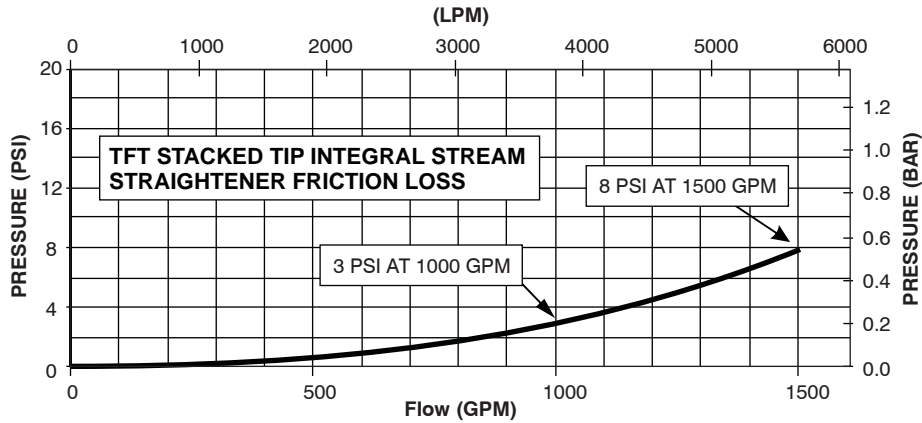
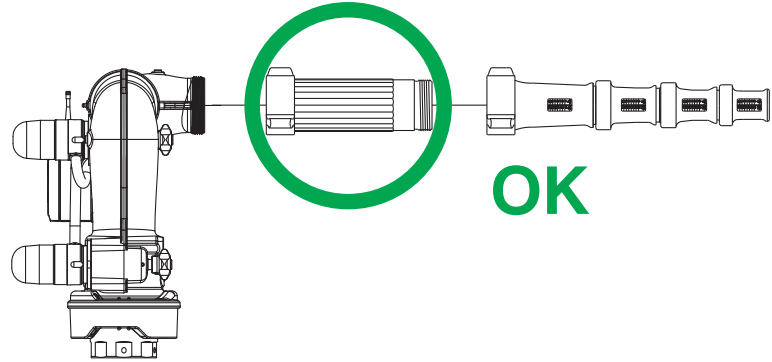
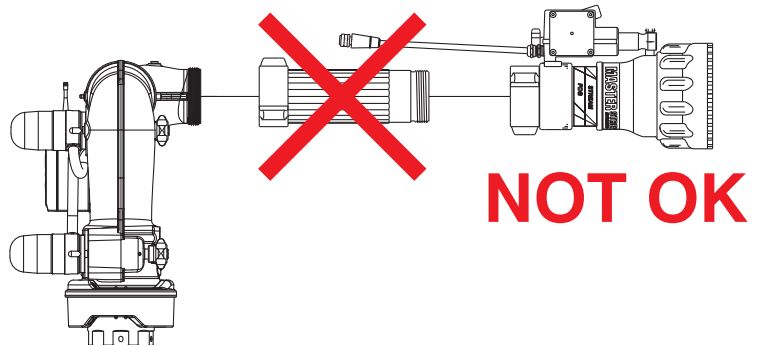

Fig 6.4.1  
TFT Stack Tip Integral Stream Straightener Friction Loss

### 6.4.2 STREAM STRAIGHTENERS WITH FOG NOZZLES

When using a fog nozzle it is recommended that no stream straightener be used since the fog nozzle's flow path generally serves as a stream straightener. Use of a stream straightener with a fog nozzle will increase the stresses on the monitor's gear train and may lead to premature wear.



## 7.0 FM APPROVAL (FACTORY MUTUAL)



FM approved monitors are identified with the symbol **FM APPROVED** on their labels.

All Manual models with FM Approval have been tested to FM Approval Class 1421 - Monitor Assembly.

RC monitors are not FM approved.

FM Approved monitors are not FM Approved for use with foam.

## 8.0 MAINTENANCE AND INSPECTION

The Typhoon Monitor requires little maintenance. The monitor should be kept clean and free of dirt. All controls should be checked for freedom of movement and proper operation before each use. Any inoperable or damaged parts should be repaired or replaced immediately.

- Make sure that the monitor's axis' rotate freely and without binding throughout its range of travel.
- Make sure that there are no leaks when the monitor is flowing water.
- Make sure the nozzle is free of debris.

Equipment can be returned to the factory for service and/or testing.

## 8.1 LUBRICATION

The Typhoon monitor generally should not require greasing. In the event that the operation becomes stiff grease may be applied to the horizontal rotation and elevation worm gears. The grease is applied by removing the plugs at the grease ports and replacing with grease fittings that have 1/4-28 male threads. See figure 7.1 for grease port locations. Use medium viscosity automotive chassis grease. Apply only enough grease to restore normal operation. If normal operation is not restored by greasing than inspect for other causes of stiff operation.

**Note: Do not over pump grease. The monitor's greased areas lead to large chambers that could trap several pounds of grease before becoming visible.**

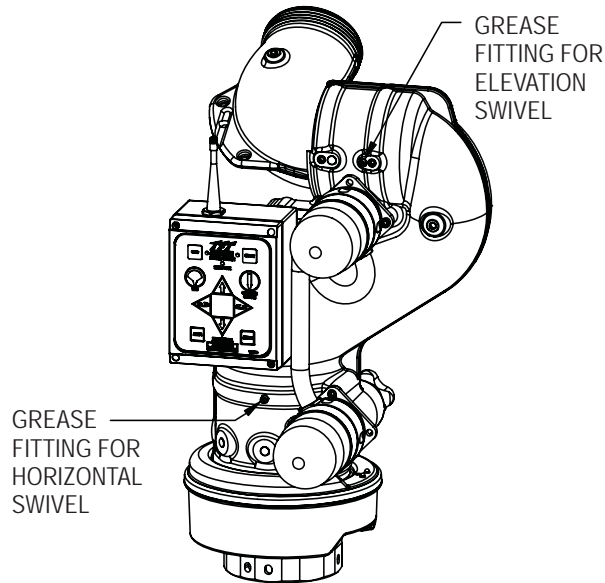

Fig 7.1  
Location of Grease Port for Horizontal Rotation  
Worm Gear and Elevator Joint

## 9.0 TROUBLESHOOTING

SYMPTOM	POSSIBLE CAUSE	REMEDY
Leaks	Debris or damage in seal area	Clean out debris or replace damaged parts
Elevation Binding	Debris or damage to elevation drive parts	Clean out debris or replace damaged parts
	Lack of lubricant	Grease, see section 7.1
Horizontal Rotation Binding	Debris or damage to horizontal drive parts	Clean out debris or replace damaged parts
	Lack of lubricant	Grease, see section 7.1

# 10.0 TYPHOON DRAWINGS & PARTS LIST

## 10.1 MANUAL TYPHOON DRAWING

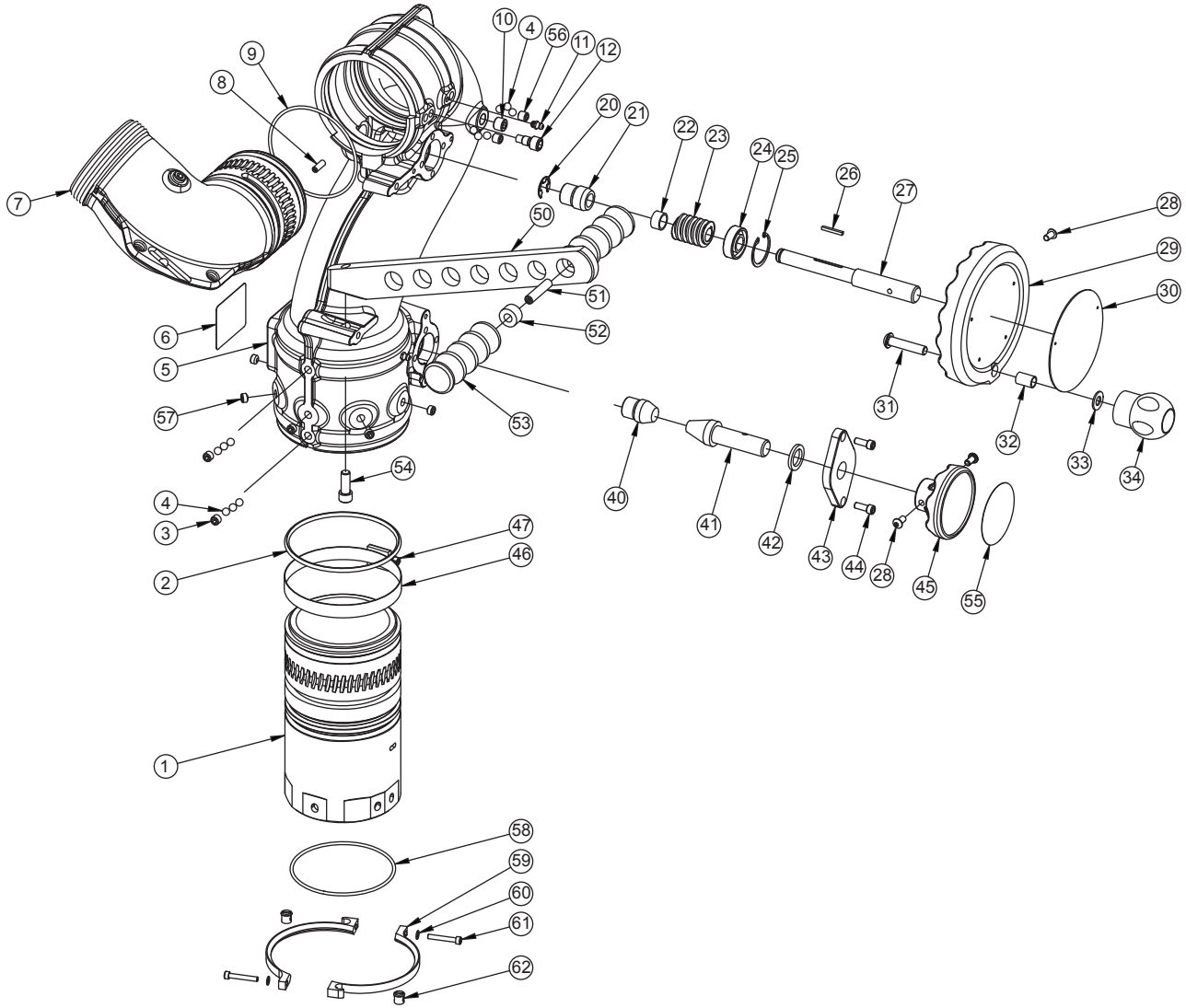

Fig 10.1  
Typhoon Mechanical Parts  
Exploded View

#	DESCRIPTION	QTY	PART #
1	BASE SHORT CODE-RPF 4"	1	Y4401A
	BASE CODE-RLF 3"		Y4405A
	BASE QUICK CONNECT 4.5"NHF SUBASSY		Y4960
	TILLER BASE QUICK CONNECT 4.5"NHF SUBASSY		Y4961
2	O-RING-350	1	VO-350
3	3/8-24 X 5/16 SOCKET SET SCREW	2	VT37-24SS312
4	5/16" TORLON BALL	184	VB.312TO
5	LOWER SECTION RC	1	Y3110A
6	NAME LABEL	1	Y3124
7	ELBOW 3 1/2"	1	Y3310A
8	1/4-28 X 3/4 SOCKET SET SCREW	2	VT25-28SS750
9	O-RING-243	1	VO-243
10	1/4"NPT PLUG	2	VFSP2M-SS
11	GREASE FITTING	2	VT25-28ZERK
12	STOP BOLT	1	Y4145
20	E-CLIP 5/8" EXTERNAL	1	VR4295
21	BUSHING	1	Y3162
22	SPACER	1	Y4150
23	12 DP WORM	1	X220
24	BEARING	1	VM4250
25	SNAP RING	1	VR4220
26	KEY	1	X225
27	DRIVE SHAFT	1	Y3160
28	1/4-20 X 1/2 BUTTON HEAD SCREW	4	VT25-20BH500
29	HANDWHEEL	1	X281
30	HANDWHEEL LABEL	1	A1306
31	3/8-16 X 1-1/2 BUTTON HEAD SCREW	1	VT37-16BH1.5
32	CRANK BUSHING	1	A1513
33	WASHER	1	VW812X406-65
34	KNOB	1	A1512
40	COVER	1	Y4192
41	LOCKING BOLT	1	Y3193
42	THIN WASHER	1	A1530
43	RETAINER	1	Y3194
44	1/4-28 X 5/8 SOCKET HEAD SCREW	2	VT25-28SH625
45	LOCKING KNOB	1	Z245
46	BAND CLAMP	1	Y3191
47	CLAMP SHIELD	1	Y3190
50	TILLER HANDLE	1	Y2316
51	3/8-16 X 1 3/4 SOCKET SET SCREW	1	VT37-16SS1.7
52	HANDLE BUSHING	1	Y2317
53	PEG	2	X362
54	3/8-16 X 1 SOCKET HEAD SCREW	1	VT37-16SH1.0
55	OVERRIDE KNOB LABEL	1	Y4176
56	3/8-24 X 3/8 SOCKET SET SCREW	2	VT37-24SS375
57	3/8-24 X 1/4 SOCKET SET SCREW	5	VT37-24SS250
58	O-RING-244 RPF-INLET	1	VO-244
	O-RING-236 RLF-INLET		VO-236
59	4" MONITOR BASE CLAMP	2	Y4435
	3" MONITOR BASE CLAMP		Y4436
60	WASHER	2	VW360X200-04
61	10-24 X 1 1/4 SOCKET HEAD SCREW	2	VT10-24SH1.2
62	CYLINDER NUT	2	Y4437

## 10.2 TYPHOON RC DRAWING

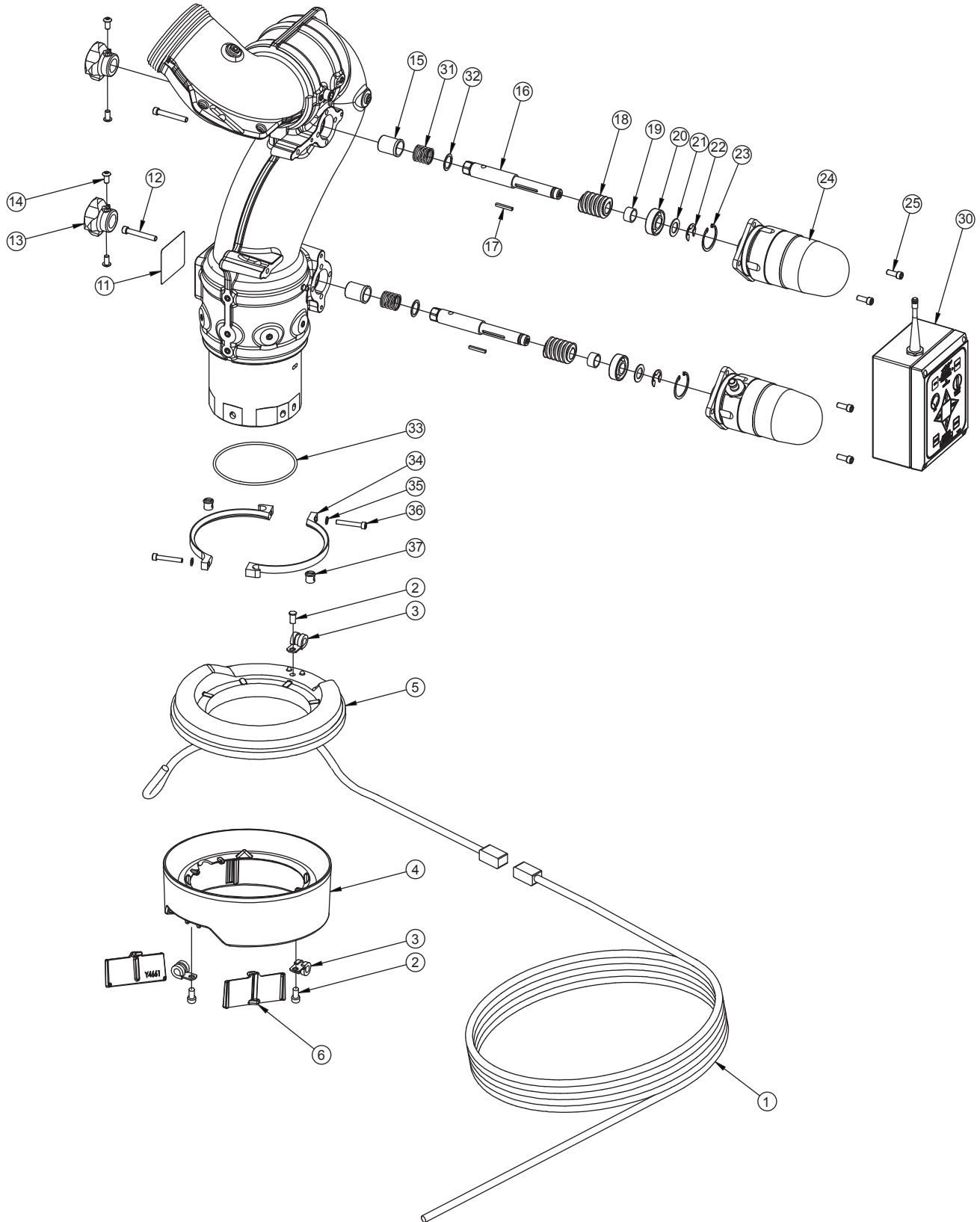

Fig 10.2  
Typhoon RC Exploded View of Electrical Parts



#	DESCRIPTION	QTY	PART #
1	CABLE - POWER & COMM.	30'	Y5200
2	1/4-20 X 1/2 BUTTON HEAD SCREW	3	VT25-20BH500
3	CLAMP	3	Y4655
4	LOWER WIRE SKIRT	1	Y4660
5	UPPER WIRE SKIRT	1	Y4650
6	WIRE SKIRT RETAINER	2	Y4661
11	NAME LABEL	1	Y3122
12	1/4-28 X 1-3/4 SOCKET HEAD SCREW	2	VT25-28SH1.7
13	OVERRIDE KNOB	2	Y3165
14	1/4-20 X 1/2 BUTTON HEAD SCREW	4	VT25-20BH500
15	HEADED BUSHING	2	Y4141
16	DRIVE SHAFT	2	Y4163
17	KEY	2	X225
18	12 DP WORM	2	X220
19	SPACER	2	Y4150
20	BEARING	2	VM4250
21	WASHER	2	VW97X595-048
22	E-CLIP 5/8" EXTERNAL	2	VR4295
23	SNAP RING	2	VR4220
24	MOTOR SUBASSEMBLY	2	SEE SECTION 10.4
25	1/4-28 X 5/8 SOCKET HEAD SCREW	4	VT25-28SH625
30	CONTROL BOX SUBASSEMBLY	1	SEE SECTION 10.3
31	SHAFT SPRING	2	Y4159
32	WASHER	2	VW1.0X759-04
33	VO-RING-244 RPF-INLET	1	VO-244
	VO-RING-236 RLF-INLET		VO-236
34	4" MONITOR BASE CLAMP	2	Y4435
	3" MONITOR BASE CLAMP		Y4436
35	WASHER	2	VW360X200-04
36	10-24 X 1 1/4 SOCKET HEAD SCREW	2	VT10-24SH1.2
37	CYLINDER NUT	2	Y4437

## 10.3 MONITOR CONTROL BOX

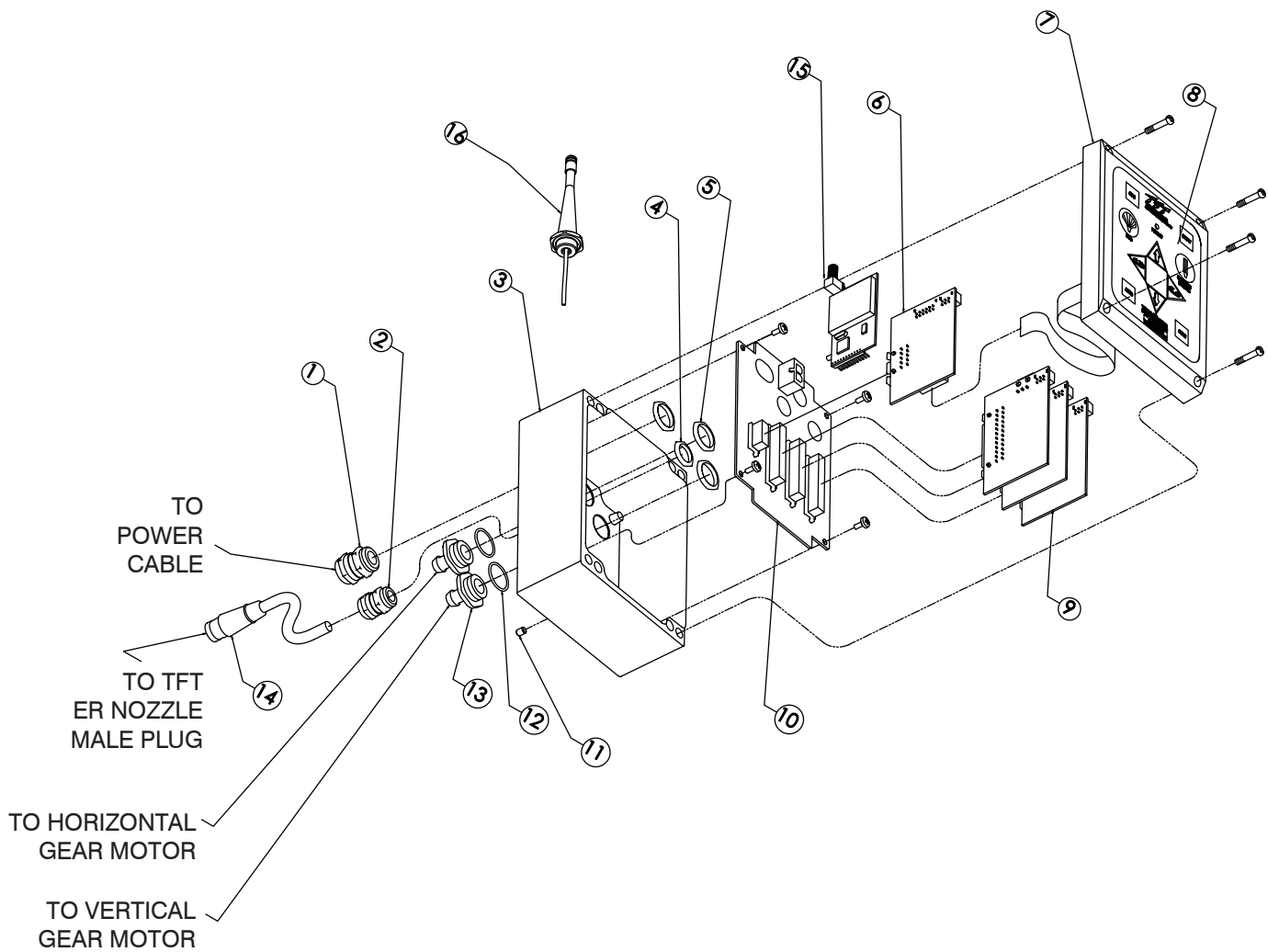

Fig 10.3  
Monitor Control Box

### TYPHOON RC CONTROL BOX PARTS LIST

#	DESCRIPTION	QTY	PART #
1	CABLE FITTING PG11	1	Y5205
2	CABLE FITTING PG9	1	Y5245
3	ENCLOSURE - BOX	1	Y5115-B
4	LOCKNUT - PG9	1	Y5246
5	LOCKNUT - PG11	3	Y5206
6	BOARD - COMMUNICATION	1	Y5110-B
7	ENCLOSURE - LID	1	Y5115-L
8	CONTROL SWITCH PAD	1	Y5700
9	BOARD - MOTOR CONTROL	3	Y5100
10	BOARD - MAIN	1	Y5105
11	V10-32 x 1/4 SET SCREW	1	VT10Y32SS250
12	O-RING-018	2	VO-018
13	CONDUIT HOSE FITTING	2	Y5213
14	FEMALE PLUG - 6 POLE	10.0" TOTAL LENGTH USED 5.0" EXPOSED CABLE (not including plug)	
15	BOARD-OEM 900 MHZ RF MODULE (included with part YE-RF-900)	1	Y5710
16	ANTENNA W/FITTING	1	Y5881

## 10.4 MOTOR SUBASSEMBLY

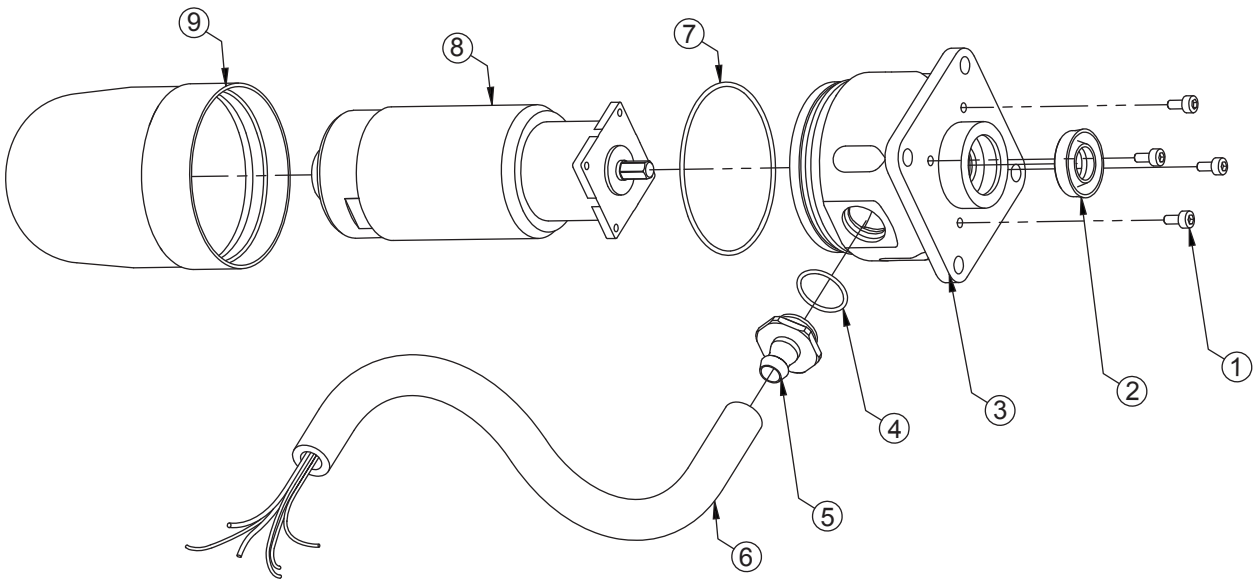

Fig 10.4  
Motor Subassembly

#	DESCRIPTION	QTY	PART #
1	6-32 x 5/16 LONG SHCS WITH HEAD SEAL	4	VT06S32SH312
2	CUP SEAL 1.0625 x .5625 x 1/4	1	Y4620
3	MOTOR SOCKET, ANGLED FITTING	1	Y4617
4	O-RING-018, 3/4 ID 1/16 CS	1	VO-018
5	CONDUIT FITTING	1	Y5213
6	HOSE - 3/8" ID PUSH-LOK	1	Y5250
7	O-RING-038, 2-5/5 ID 1/16 CS	1	VO-038
8	GEAR MOTOR WITH ENCODER	1	Y4611
9	ENCLOSURE	1	Y4616

## 11.0 WARRANTY

Task Force Tips, Inc., 3701 Innovation Way, Valparaiso, Indiana 46383-9327 USA ("TFT") warrants to the original purchaser of its Typhoon and Typhoon RC Monitor ("equipment"), and to anyone to whom it is transferred, that the equipment shall be free from defects in material and workmanship during the five (5) year period from the date of purchase.

TFT's obligation under this warranty is specifically limited to replacing or repairing the equipment (or its parts) which are shown by TFT's examination to be in a defective condition attributable to TFT. To qualify for this limited warranty, the claimant must return the equipment to TFT, at 3701 Innovation Way, Valparaiso, Indiana 46383-9327 USA, within a reasonable time after discovery of the defect. TFT will examine the equipment. If TFT determines that there is a defect attributable to it, it will correct the problem within a reasonable time. If the equipment is covered by this limited warranty, TFT will assume the expenses of repair.

If any defect attributable to TFT under this limited warranty cannot be reasonably cured by repair or replacement, TFT may elect to refund the purchase price of the equipment, less reasonable depreciation, in complete discharge of its obligations under this limited warranty. If TFT makes this election, claimant shall return the equipment to TFT free and clear of any liens and encumbrances.

This is a limited warranty. The original purchaser of the equipment, any person to whom it is transferred, and any person who is an intended or unintended beneficiary of the equipment, shall not be entitled to recover from TFT any consequential or incidental damages for injury to person and/or property resulting from any defective equipment manufactured or assembled by TFT. It is agreed and understood that the price stated for the equipment is in part consideration for limiting TFT's liability. Some states do not allow the exclusion or limitation of incidental or consequential damages, so the above may not apply to you.

TFT shall have no obligation under this limited warranty if the equipment is, or has been, misused or neglected (including failure to provide reasonable maintenance) or if there have been accidents to the equipment or if it has been repaired or altered by someone else.

THIS IS A LIMITED EXPRESS WARRANTY ONLY. TFT EXPRESSLY DISCLAIMS WITH RESPECT TO THE EQUIPMENT ALL IMPLIED WARRANTIES OF MERCHANTABILITY AND ALL IMPLIED WARRANTIES OF FITNESS FOR A PARTICULAR PURPOSE. THERE IS NO WARRANTY OF ANY NATURE MADE BY TFT BEYOND THAT STATED IN THE DOCUMENT.

This limited warranty gives you specific legal rights, and you may also have other rights which vary from state to state.