

INSTRUCTIONS FOR PROPER OPERATION AND MAINTENANCE

⚠ DANGER

Understand manual before use. Operation of this device without understanding the manual and receiving proper training is a misuse of this equipment. Obtain safety information at tft.com/serial-number

⚠ WARNING

Sudden change in monitor position of an insecurely installed monitor can result in spray impact or water sprayed in unintended directions causing injury or death. Verify the mount and monitor are correctly and securely installed on an object capable of supporting reaction force and torque under maximum flow conditions.

This Instruction Manual is intended to familiarize firefighters and maintenance personnel with the operation, servicing, and safety procedures associated with the portable monitor, and should be kept available to all operating and maintenance personnel.

**Maximum Pressure at no flow:
300 PSI (20 bar)**

**Maximum Operating Condition:
175 PSI (12 bar) @ 500 GPM
(2000 l/min)**

**Hydrostatic Proof Test:
900 PSI (62 bar) per NFPA 1965**

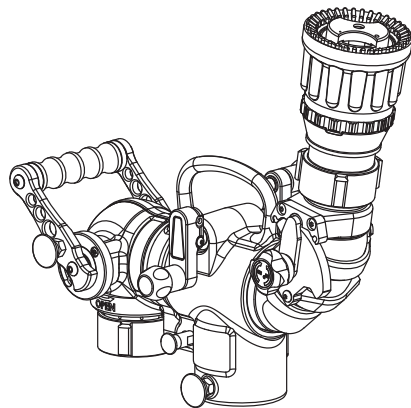

Hemisphere Monitor
(Shown with optional Max-Force nozzle)

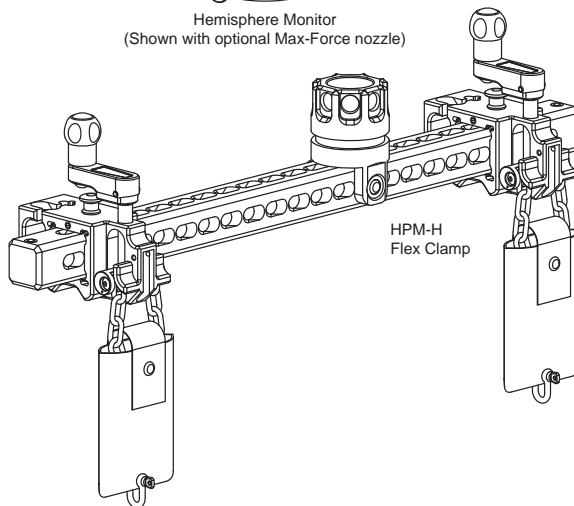

HPM-H
Flex Clamp

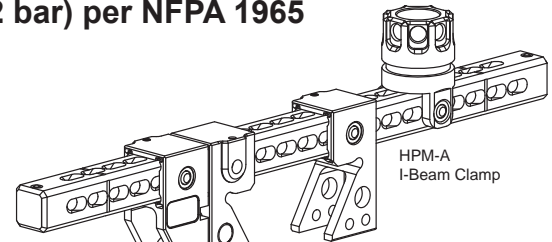

HPM-A
I-Beam Clamp

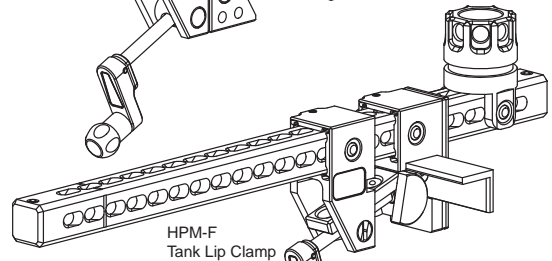

HPM-F
Tank Lip Clamp

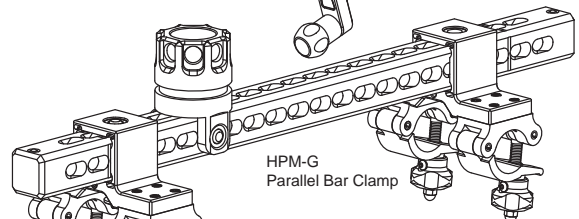

HPM-G
Parallel Bar Clamp

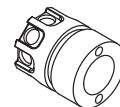

HPM-B Fixed Mount

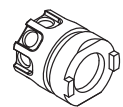

HPM-C Hitch Mount



HPM-D Mount Block

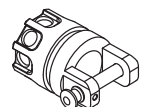

HPM-E Cross-Pin Mount

Table Of Contents

1.0 MEANING OF SAFETY SIGNAL WORDS	3.0 FLOWS AND PRESSURES
2.0 GENERAL INFORMATION	3.1 AUTOMATIC, FIXED, AND SELECTABLE FLOW NOZZLES
2.1 HEMISPHERE PART IDENTIFICATION	3.2 STACKED TIPS OR SMOOTHBORE NOZZLES
2.2 INSTALLING CLAMPS AND MOUNTS	3.3 STREAM STRAIGHTENERS
2.2.1 I-BEAM CLAMP/2" HITCH MOUNT	3.4 USE WITH FOAM
2.2.1.1 I-BEAM CLAMP MOUNTING	3.5 USE WITH SALT WATER
2.2.1.2 2" HITCH RECEIVER MOUNTING	3.6 HEMISPHERE PRESSURE LOSS
2.2.2 HITCH MOUNT	3.7 HEMISPHERE OPERATING ENVELOPE
2.2.3 FIXED MOUNT	4.0 EXPLODED VIEWS AND PARTS LISTS
2.2.4 MOUNTING BLOCK	4.1 HEMISPHERE MONITOR EXPLODED VIEW & PARTS LIST
2.2.5 CROSS-PIN MOUNT	4.2 DOUBLE BALL SWIVEL EXPLODED VIEW & PARTS LIST
2.2.6 TANK LIP CLAMP	4.3 I-BEAM CLAMP EXPLODED VIEW & PARTS LIST
2.2.7 PARALLEL BAR CLAMP	4.4 TANK LIP CLAMP EXPLODED VIEW AND PARTS LIST
2.2.8 FLEX CLAMP	4.5 PARALLEL BAR CLAMP EXPLODED VIEW AND PARTS LIST
2.2.8.1 CHAIN SAFETY	4.6 FLEX CLAMP EXPLODED VIEW AND PARTS LIST
2.2.8.2 CHAIN BENDING	5.0 WARRANTY
2.2.8.3 MINIMUM BEND RADIUS REQUIREMENT	6.0 MAINTENANCE
2.2.8.4 CHAIN AND SHACKLE INSPECTION	6.1 SERVICE TESTING
2.2.8.5 FLEX CLAMP INSTALLATION	6.1.1 HYDRAULIC TESTING
2.2.8.6 ADDING CHAIN FOR LARGER OBJECTS	6.1.2 SHUTOFF VALVE TEST
2.3 INSTALLING THE MONITOR ONTO THE MOUNT	6.1.3 RECORDS
2.3.1 RELEASING THE MONITOR FROM THE MOUNT	6.2 REPAIR
2.3.2 PRESSURE GAUGE PORT	6.3 DOUBLE BALL PIVOT SYNCHRONIZER AND LOCK MAINTENANCE
2.3.3 ROTATING THE MONITOR ABOUT THE MOUNT	6.4 LOCK PIN ASSEMBLY
2.3.4 SAFETY MECHANISM	7.0 ANSWERS TO YOUR QUESTIONS
2.4 POINTING THE NOZZLE	8.0 OPERATION AND INSPECTION CHECKLIST
2.4.1 HEMISPHERE COVERAGE	
2.4.2 PIVOTING THE OUTLET	
2.4.3 LOCKING THE OUTLET PIVOTS	
2.4.4 ROTATING THE WATERWAY	
2.4.5 QUARTER TURN VALVE	



PERSONAL RESPONSIBILITY CODE

The member companies of FEMSA that provide emergency response equipment and services want responders to know and understand the following:





1. Firefighting and Emergency Response are inherently dangerous activities requiring proper training in their hazards and the use of extreme caution at all times.
2. It is your responsibility to read and understand any user's instructions, including purpose and limitations, provided with any piece of equipment you may be called upon to use.
3. It is your responsibility to know that you have been properly trained in Firefighting and /or Emergency Response and in the use, precautions, and care of any equipment you may be called upon to use.
4. It is your responsibility to be in proper physical condition and to maintain the personal skill level required to operate any equipment you may be called upon to use.
5. It is your responsibility to know that your equipment is in operable condition and has been maintained in accordance with the manufacturer's instructions.
6. Failure to follow these guidelines may result in death, burns or other severe injury.



Fire and Emergency Manufacturers and Service Association
P.O. Box 147, Lynnfield, MA 01940 • www.FEMSA.org

1.0 MEANING OF SAFETY SIGNAL WORDS

A safety related message is identified by a safety alert symbol and a signal word to indicate the level of risk involved with a particular hazard. Per ANSI standard Z535.6-2011, the definitions of the four signal words are as follows:

	DANGER indicates a hazardous situation which, if not avoided, will result in death or serious injury.
	WARNING indicates a hazardous situation which, if not avoided, may result in death or serious injury.
	CAUTION indicates a potentially hazardous situation which, if not avoided, could result in minor or moderate injury.
	NOTICE is used to address practices not related to physical injury.

2.0 GENERAL INFORMATION

The Hemisphere is a versatile, lightweight, and easy to deploy transportable monitor that gives the user the ability to quickly establish water flow in locations that ground monitors cannot. Since the Hemisphere doesn't rely on gravity for stability, it can be pointed horizontal and down, in addition to up, unlike portable ground monitors. The rotating, pivoting waterway, allows the stream to be directed in virtually any direction, within a hemispherical range, without interrupting water flow. A variety of mounts, including an I-beam clamp that doubles as a 2" receiver hitch mount, a dedicated hitch mount, and fixed mounts, provide the user the ability to quickly attach the monitor, and establish coverage on the fire ground, or in preplanned locations. An integrated, quarter turn, hardcoat anodized aluminum half ball valve, with locking bail handle, provides shutoff capability. The main and valve bodies are hardcoat anodized aluminum inside and out, with a blue TFT powder coat finish, on the outside. General product specifications are as follows:

- Standard Inlet Coupling: 2 ½ inch NH Female
- Standard Outlet: 2 ½ inch NH male
- Mounting Positions: 8 positions, every 45 degrees (shutdown to reposition)
- Double Ball Pivot Sweep: 80 degrees (while flowing)
- Main Waterway Rotation: 360 degrees (while flowing)
- Hose Approach: 90 degree inlet valve rotates 360 degrees
- Size: 25.5"L x 8.1"W x 10"H (650mm x 210mm x 260mm) (without nozzle, I-beam clamp, or mounts)
- Weight: 22 lbs (10 kg) (without nozzle, I-beam clamp, or mounts)

 **WARNING** This equipment is intended for use by trained personnel for firefighting. Its use for other purposes may involve hazards not addressed by this manual. Seek appropriate guidance and training to reduce risk of injury.

 **WARNING** An out of control monitor can cause injury or death. Risk can be reduced by:

- Carefully select structural members for monitor mounting which are capable of safely resisting reaction forces which can be as high as 350 lbf (160 kg)
- Do not attempt to remove the monitor from its clamp or mounting block while flowing.
- Do not attempt to re-position the monitor on its 8 position mount while flowing
- Do not attempt to readjust the I-beam clamp while flowing
- Immediately retreat to a safe distance if the clamp or mount does not appear secure
- Shut down the water hose at its source before attempting to re-secure the monitor

 **WARNING** Interrupting flow to the monitor may cause injury or death. Avoid situations that may interrupt flow to the monitor such as: hose line kinks, traffic running over hose, and automatic doors or devices that can pinch the hose.

 **CAUTION** Master streams are powerful and capable of causing injury and property damage. Make sure the monitor is pointing in a safe direction before water to the nozzle is turned on. Use care in directing the stream.

 **CAUTION** Monitor must be properly connected to hose and nozzle. Mismatched or damaged threads may cause leaking or uncoupling under pressure and could cause injury.

 **CAUTION** Do not couple aluminum to brass. Dissimilar metal coupled together can cause galvanic corrosion that can result in inability to unscrew threads or complete loss of thread engagement over time.

 **CAUTION** Use with salt water is permissible provided the monitor is thoroughly cleaned with fresh water after each use. The service life of the monitor may be shortened due to the effects of corrosion and is not covered under warranty.

2.1 HEMISPHERE PART IDENTIFICATION

The Hemisphere can be mounted on a variety of mounts, each of which includes a standard profile that the Hemisphere attaches to. Figure 2.1 identifies the various parts and controls on a standard Hemisphere transportable monitor and HPM-A I-beam clamp/2" hitch mount.

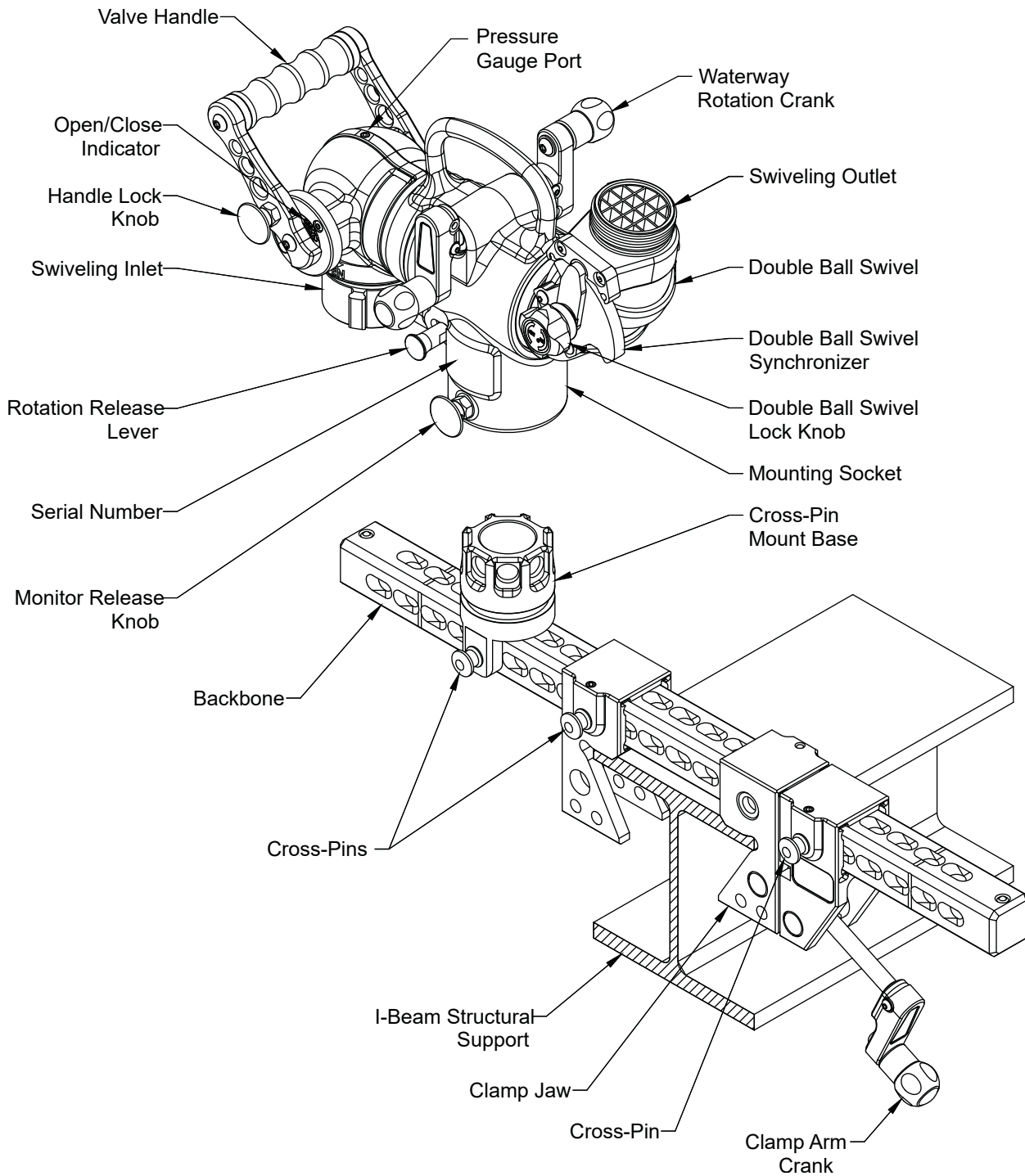

Figure 2.1 Identifies the Various Parts and Controls on a Standard Hemisphere Transportable Monitor and HPM-A I-Beam Clamp/2" Hitch Mount

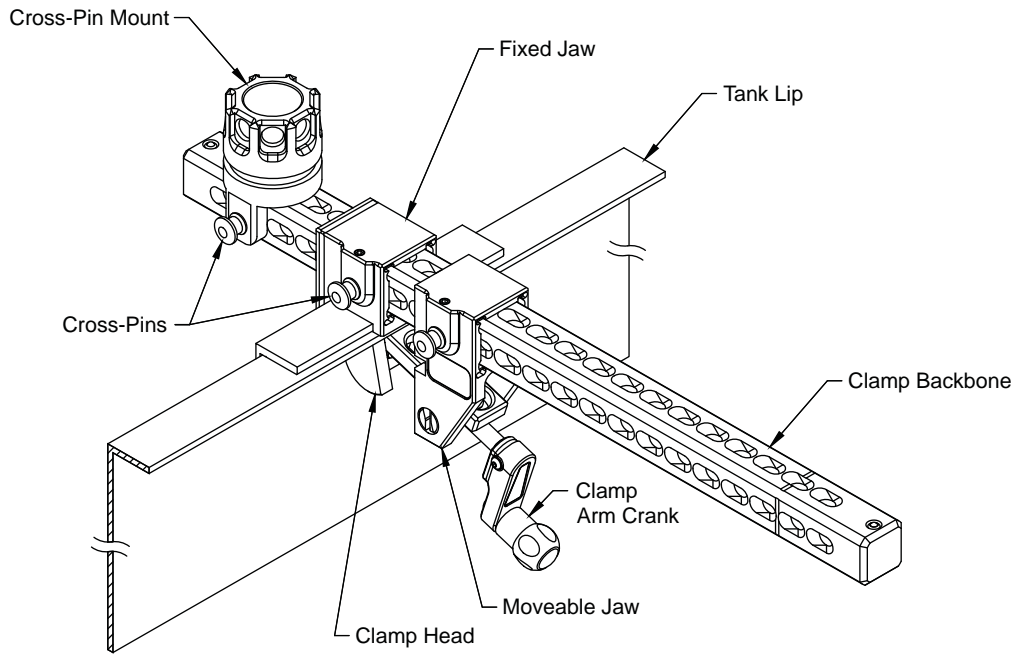

Figure 2.2 Identifies the Various Parts and Controls on HPM-F Tank Lip Clamp

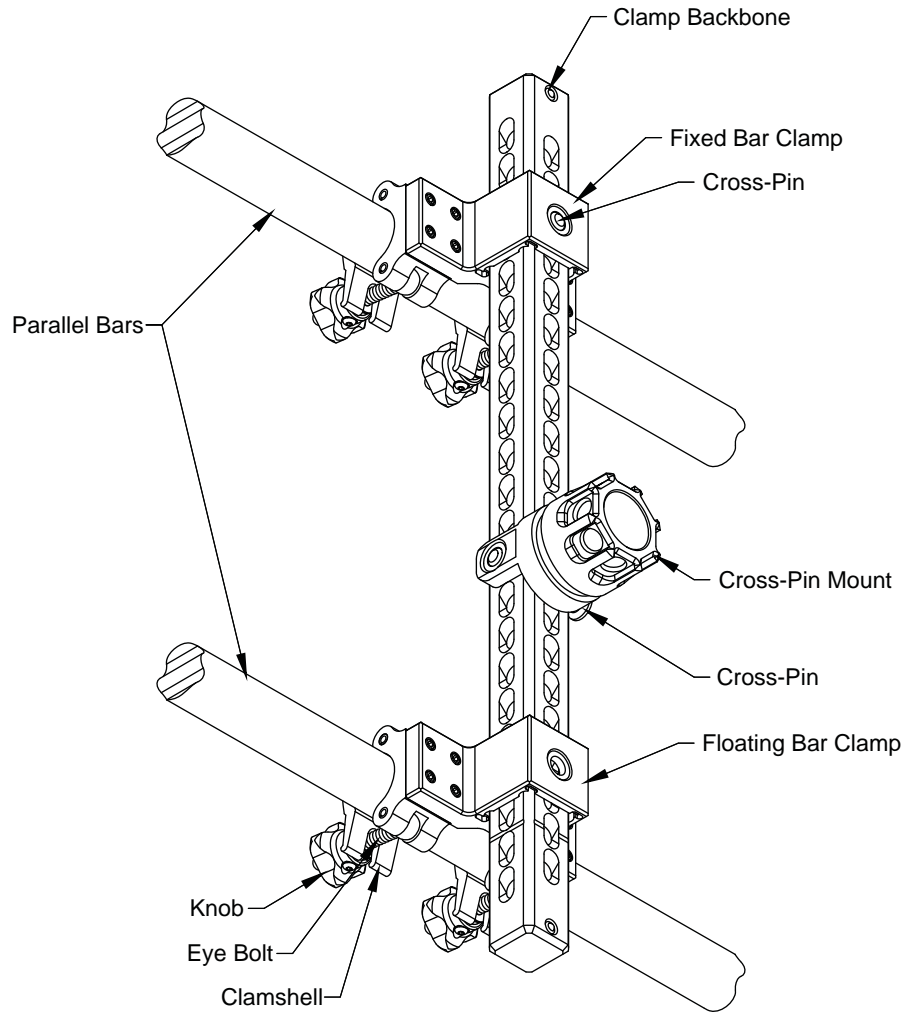

Figure 2.3 Identifies the Various Parts and Controls on HPM-G Parallel Bar Mount

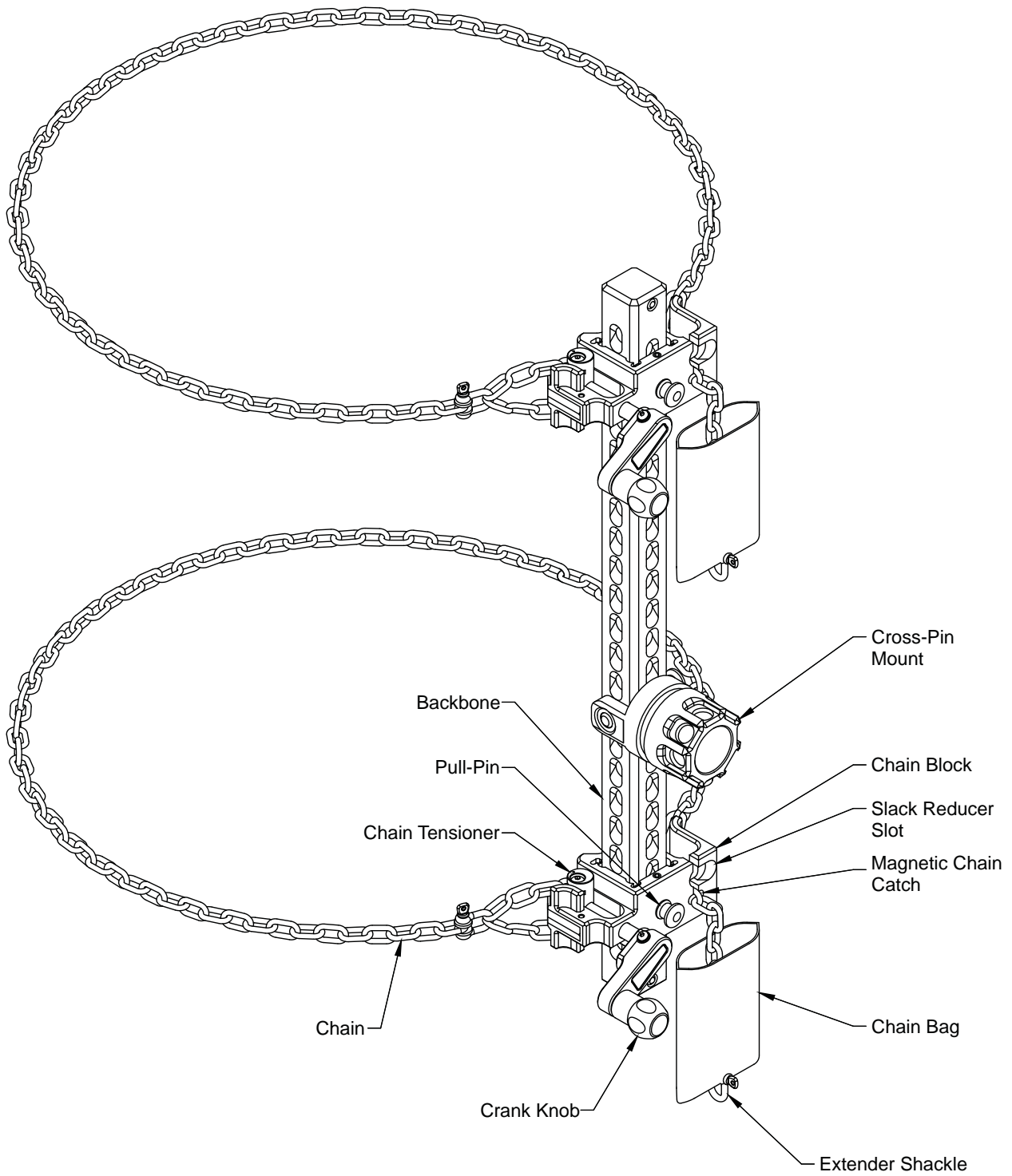

Figure 2.4 Identifies the Various Parts and Controls on HPM-H Flex Clamp

2.2 INSTALLING CLAMPS AND MOUNTS

⚠️ WARNING Monitor clamps and mounts installed on poor or weak objects can become unstable causing an out of control monitor resulting in injury or death. Choose robust stationary objects capable of safely supporting monitor reaction force, torques, hose load, and vibration.

⚠️ CAUTION Falling hazard. Use care when transporting, installing, and using the Hemisphere, its mounts, nozzle, and hose from an elevated position. Select mount locations where there is no need to lean out beyond the confines of safety railings and always wear proper fall protection gear.. Avoid situations posing a drop hazard to persons below.

The Hemisphere I-beam clamp is designed primarily for I-beams, but can be installed on other suitable objects, provided the mounted object's geometry and strength are such that the reaction forces and weight of the monitor, water, and attached hose are safely constrained. Consideration should be given to the ability of the mounted object to support loads created as a result of the weight of the monitor, with charged hose, and attachments, such as nozzles, foam eductors, etc..., and torque produced by reaction force and charged hose. An example of a potentially unsafe object would be a process pipe that hasn't been internally inspected, and could have thin walls due to internal corrosion/erosion. Another unsafe example could be using the I-beam clamp to attach to an I-beam with fireproofing that could break off and allow the clamp to become dislodged. The most reliable object is one that has been load tested under actual operating conditions.

Although it is physically possible to attach more than one monitor to the backbone, great care should be taken when doing so, and under no circumstance should more than two monitors be attached to a backbone. The tank lip and flex clamps should never have more than one monitor attached. The I-beam and parallel bar clamps can support more than one monitor under most circumstances, but many mounted objects will fail under the load that can be generated by two monitors. We do not recommend using two monitors on one backbone, but we do acknowledge that it can be done. Under most circumstances that two monitors can be attached to one backbone, two backbones can be attached with one monitor on each, and it will be safer.

2.2.1 I-BEAM CLAMP/2" HITCH MOUNT

The I-beam clamp / 2" hitch mount provides a versatile solution for mounting the Hemisphere. With the ability to clamp, as well as attach to a 2" hitch receiver, this mount can get the Hemisphere into locations that other monitors cannot.

2.2.1.1 I-BEAM CLAMP

Before attaching to an I-beam, or other suitable object, the clamp must first be configured to position the monitor in relation to the clamped object. Care must be taken to allow the monitor unobstructed access to the fire, and the user unobstructed access to the monitor controls. Plan the mounting position to give good clearance for the hose, room to operate the valve handle, and plenty of freedom to point the monitor where needed. Figure 2.5 shows the clamp components and installation layout. The cross-pin mount and fixed end include detented cross-pins, with travel stops to prevent the pins from being dropped or lost. The backbone is designed, such that the cross-pin mount and the fixed jaw can be attached at any of the 43 cross holes, including both above and below, for a total of 86 possible positions. Although all 86 positions are possible, they may not all make sense for certain applications. The angled face of the fixed jaw should be aligned opposite the angled face of the clamp arm, as shown. If the fixed jaw is installed in the wrong orientation, the clamp will not hold. Be sure to install the fixed jaw far enough away from the clamp arm to allow the I-beam, or other suitable mounting object, to fit into the clamp.

Retract the clamp jaw by rotating the crank arm counterclockwise. Slide clamp arm assembly onto the backbone until it is past the detent ball to prevent it from sliding off.

Upon verifying that all components are properly installed and secure, the clamp is ready to install.

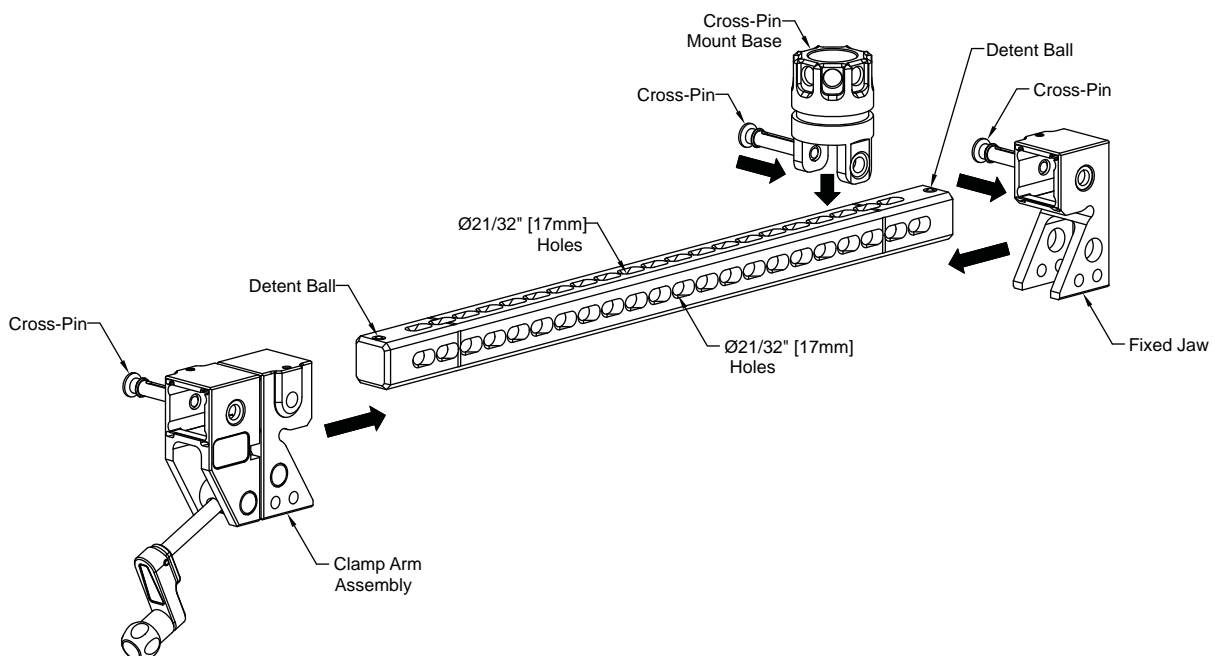

Figure 2.5 I-Beam Clamp Assembly

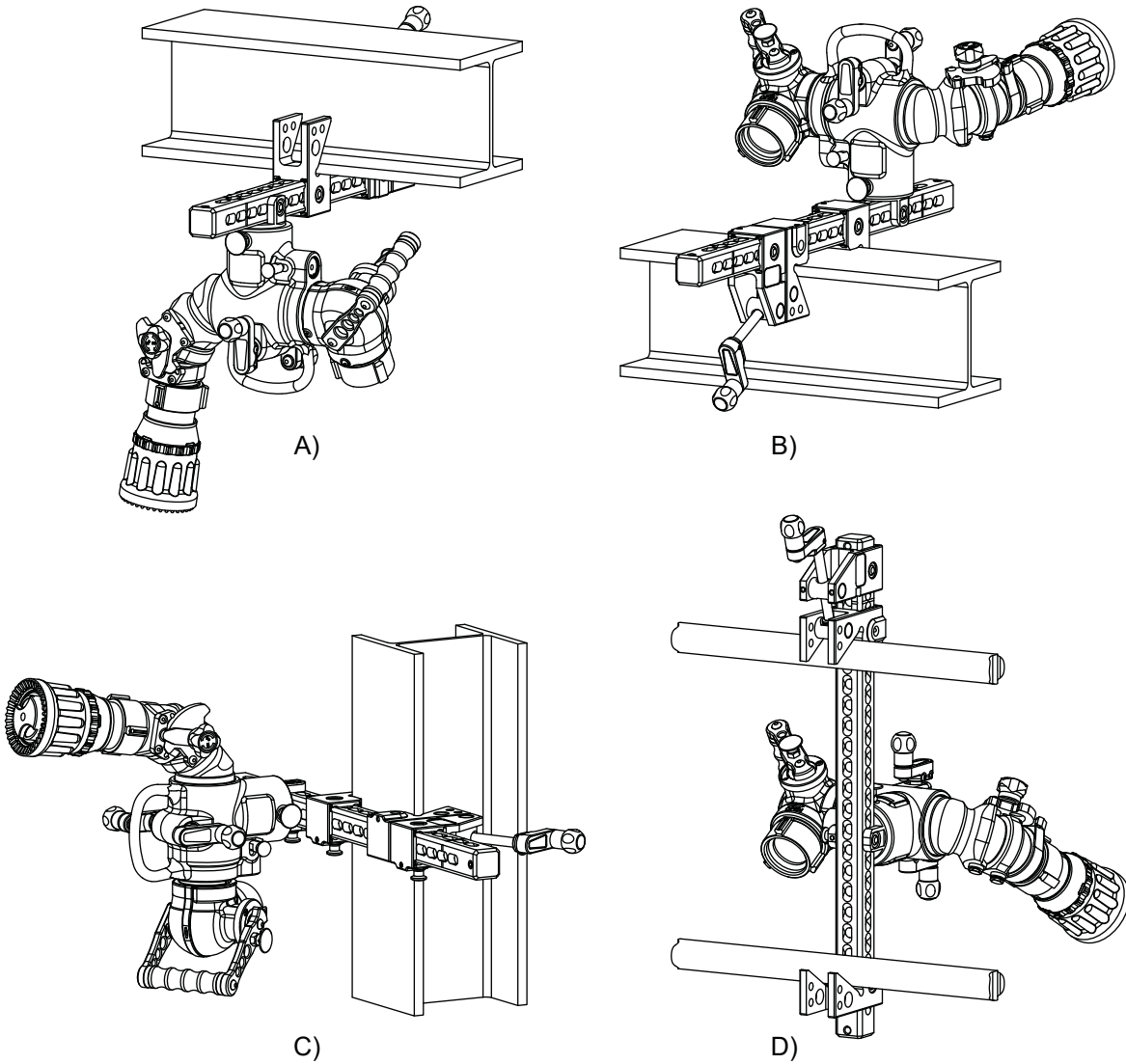

Figure 2.6: Several different possible clamping orientations

Several orientations are possible when clamping to I-beams, stair rails, and other suitable geometry. Figure 2.6 shows some examples of possible orientations. Different orientations may make more sense than others, depending on what direction the nozzle will need to point, and available space. The vertical mounting in figure 2.6C, for example, would make more sense than the horizontal mounting in figure 2.6B if a wide range of horizontal movement is needed, and the stream won't need to point below horizontal. The mounting in 2.6B would make more sense if a wide range of vertical movement, with below horizontal movement is anticipated, and the quick sweeping ability of the double ball swivel is useful in the horizontal orientations, as shown. Figure 2.6D shows the I-beam clamp attached to a hand rail.

Figure 2.7 prescribes the maximum flange thickness and width the I-beam clamp is designed to attach to. These dimensional maximums should not be exceeded, no matter what the clamp is attached to. Parallel beams of round and angle cross-section (as would commonly be encountered on hand rails), or any other cross-sectional shapes, also, must not exceed these dimensions.

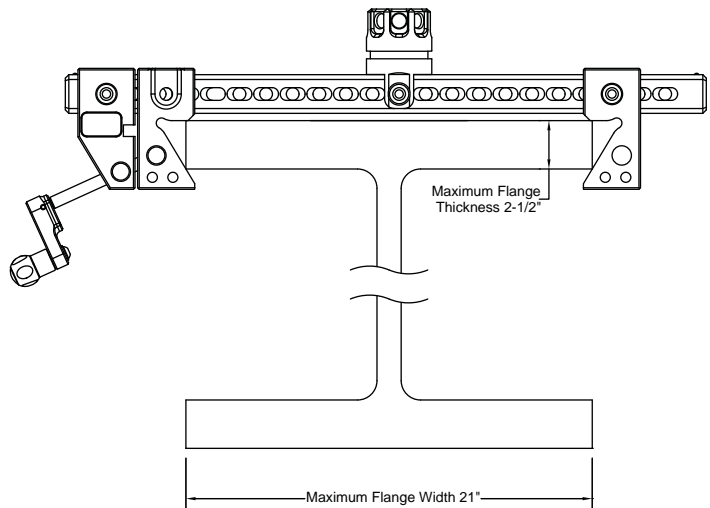

Figure 2.7 Maximum Flange Dimensions

⚠ DANGER Exceeding the maximum flange thickness creates an unsafe operating condition, and will compromise the ability of the clamp to maintain a fixed position, resulting in an out of control monitor. An out of control monitor can cause injury, death, and/or property damage.

Step 1

With the clamp jaw fully retracted, position the fixed jaw against the I-beam, as shown in figure 2.8. Push the clamp jaw toward the I-beam.

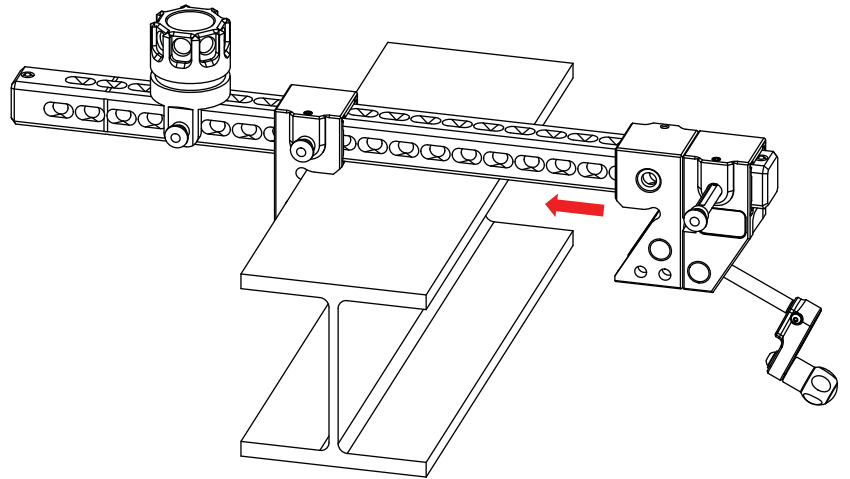

Figure 2.8 I-Beam Clamp installation Step 1

Step 2

When the edge stop contacts the edge of the I-beam, as shown in figure 2.9, pull the clamp jaw assembly back to the next closest cross hole and slide the cross-pin through the backbone.

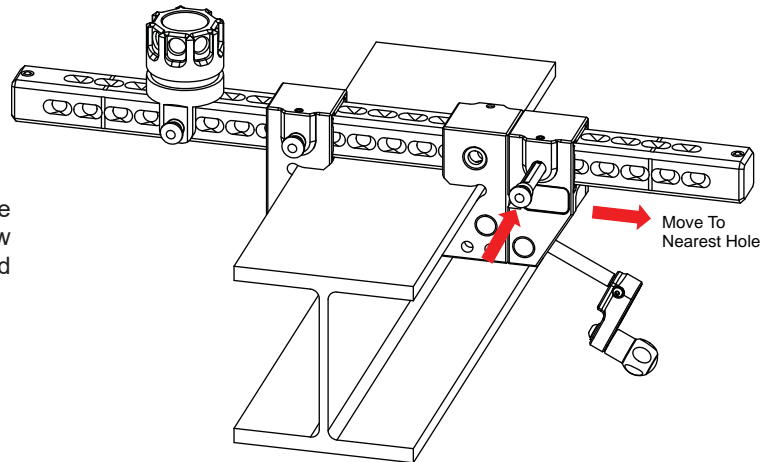

Figure 2.9 I-Beam Clamp Installation Step 2

Step 3

With the cross-pin detented firmly in place, rotate the crank clockwise, to engage the clamp jaws, until snug.

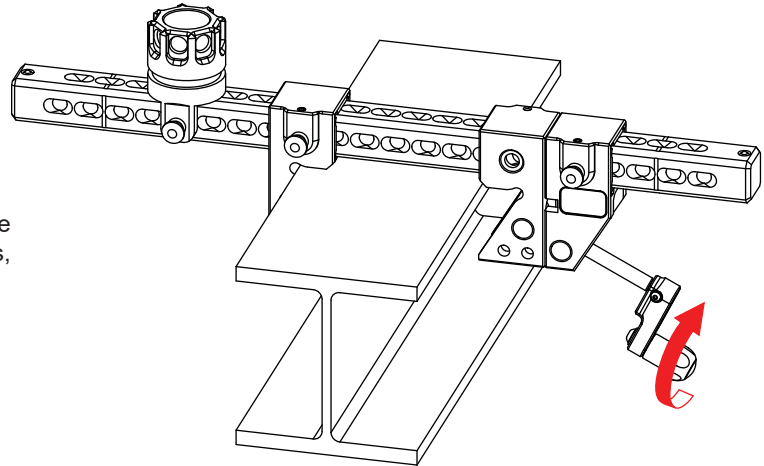

Figure 2.10 I-Beam Clamp Installation Step 3

Step 4

Rotate the crank one full turn past snug, as shown in fig 2.11, and attempt to shake the clamp assembly. If the clamp is able to move in relation to the mounted object, rotate the crank until the clamp is firmly seated against the I-beam. After use: Ensure clamp is fully retracted (unscrewed) for storage.

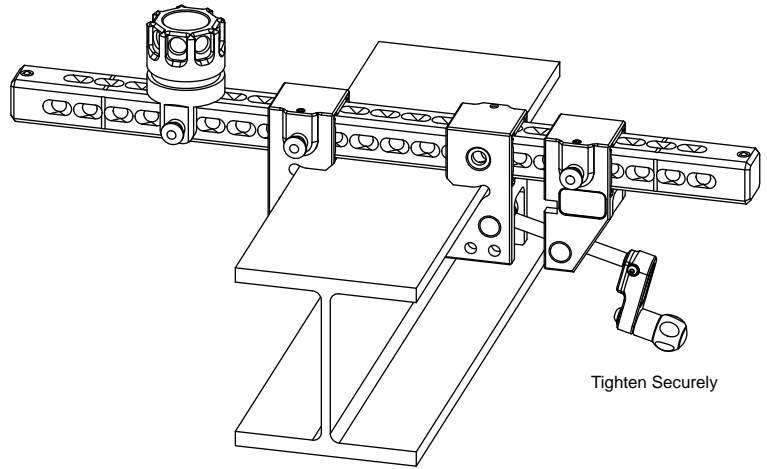

Figure 2.11 I-Beam Clamp Installation Step 4

WARNING

Overtightening the I-beam clamp can distort or damage the clamp resulting in an insecure monitor mounting that will not safely support reaction forces. Don't turn crank more than one turn after the jaws are fully seated and crank arm has stopped moving. Don't tighten the crank with a wrench, tool, or cheater bar.

2.2.1.2 2" HITCH RECEIVER MOUNTING

The backbone for the I-beam clamp is sized to fit into any standard 2" x 2" Class III or Class IV hitch receiver, and the crossholes are sized to accept a standard 5/8" [16mm] hitch pin, allowing instant attachment to hitch receiver equipped vehicles. The clamp jaw and fixed jaw assemblies are not needed when installed in a hitch, but they can be left on, if convenient. The same cross-pin mount used when attaching to I-beams is used when attaching to a hitch receiver. Be sure that the backbone is fastened to the hitch receiver with a hitch pin, and the hitch pin is retained by a cotter-pin or other retention device before charging the hose line.



CAUTION

Unsecured monitors will move suddenly when flow is initiated. Cross pin must be installed and secured before charging hose or flowing monitor.

2.2.2 HITCH MOUNT

The hitch mount is designed to be installed on a standard 2" class III hitch. The hitch ball, nut, and lock washer must first be removed. The hitch mount washer is then inserted into the mount, and the mount is placed flush against the hitch tongue, with the alignment tabs on the sides, on the side opposite of the desired position of the ball. Be sure that the tongue won't interfere with the monitor. Insert the hitch ball through the tongue and hitch mount washer. Fasten the nut and lock washer to the hitch ball. The mount can be left in place while towing, provided sufficient clearances from the ground and other objects exist. The hitch mount should never be used for anything other than mounting a monitor. Never attempt to tow or pull with the hitch mount.

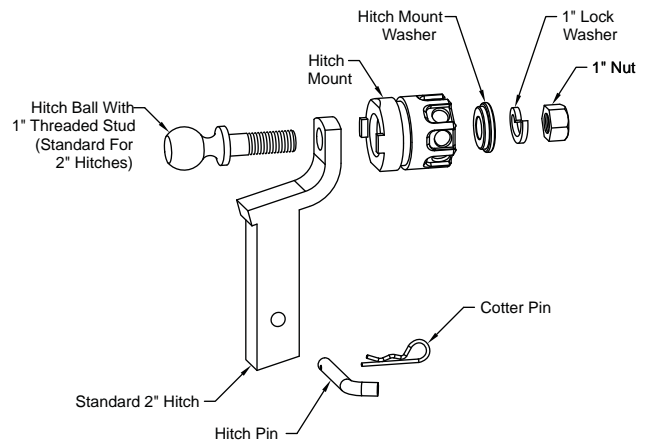

Figure 2.12 Hitch Mount Installation

2.2.3 FIXED MOUNT

Fixed mounts can be installed in preplanned locations for fast, precise setup. Two (2) 1/2"-20 screws, with washers, spaced 2.69" [68mm] apart are required (not included), and are installed from the back side of a mounting surface that has been pre-drilled with two (2) .52" [13mm] clearance holes. The screws must be long enough to engage at least .75" [19mm], and no more than 1" [25mm] into the tapped holes on the mount. The mounting surface and fasteners must be able to support the weight of the monitor and all attachments, including the water contained within the monitor and hoses, and also the torque resulting from the reaction forces and hoses.

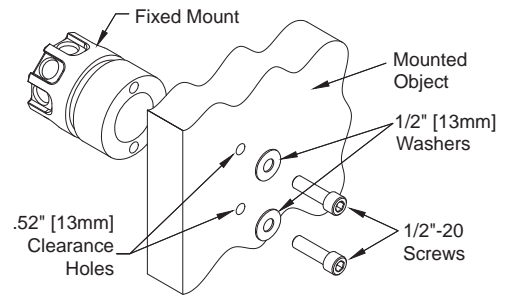

Figure 2.13 Fixed Mount Installation

2.2.4 MOUNTING BLOCK

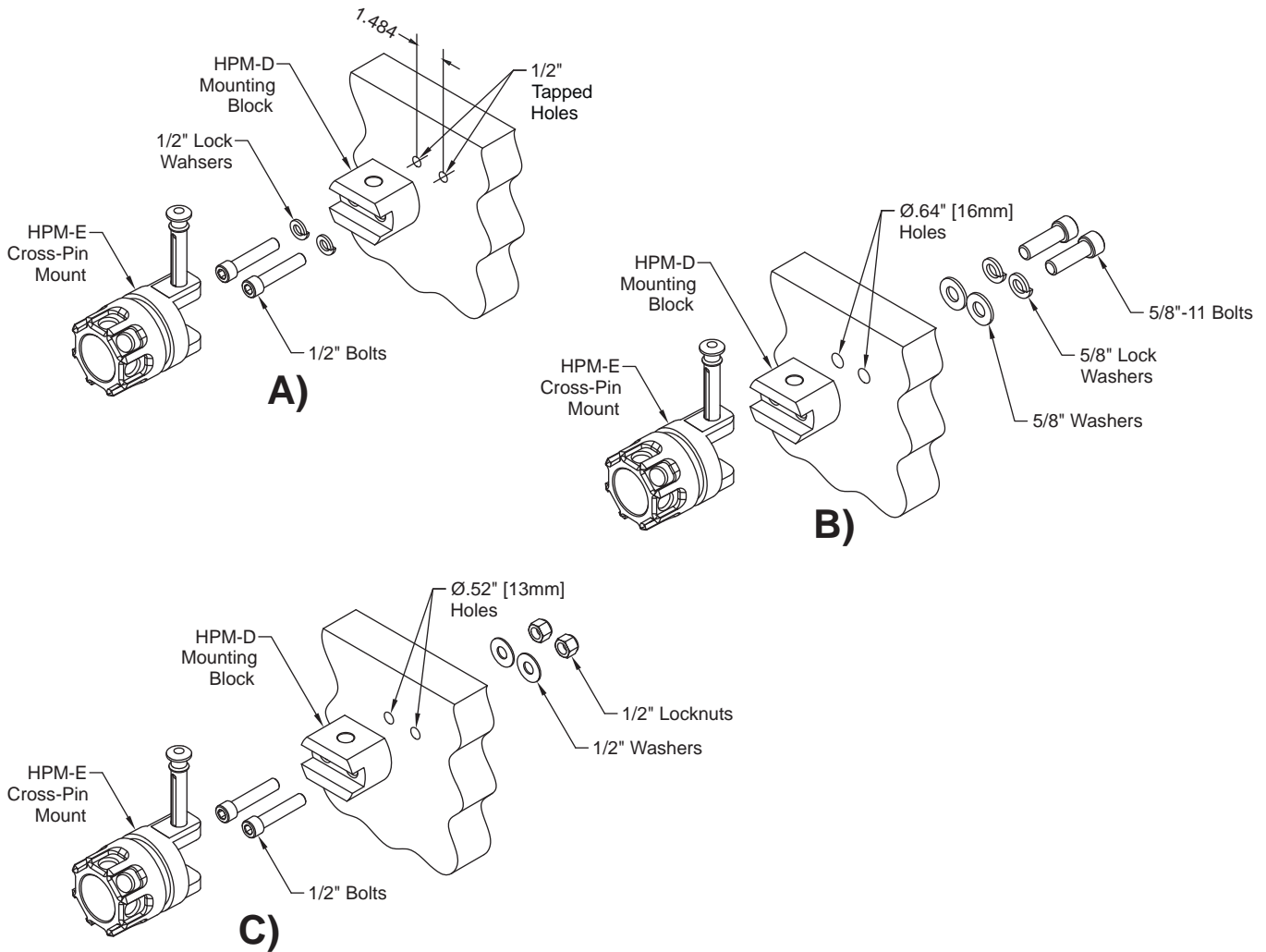

Figure 2.14 Mounting block installation options

A mounting block can be used as a fixed mount, for flowing, or as a storage bracket for the Hemisphere monitor. This mount can be used in locations where the back side of the mounting surface is inaccessible. It can be bolted from the front of a sufficiently rigid surface by adding two 1/2" [13mm] tapped holes (See figure 2.14 a.) It can also be bolted from the back side of a surface, by drilling two (2) .64" [16mm] clearance holes (See figure 2.14 b.) and screwing two (2) 5/8"-11 bolts into the tapped holes on the bracket. A third option would be to drill two (2) .52" holes, and bolting the mounting block from the front side with 1/2" bolts, washers, and locknuts (See figure 2.14 c.)

2.2.5 CROSS-PIN MOUNT

A cross-pin mount can be added to a mounting block to create a monitor-ready attachment location (See Figure 2.14.) It is the same cross-pin mount that is included with the I-beam clamp/2" hitch mount, with the same detented cross-pin, and can be ordered as a spare or replacement.

2.2.6 TANK LIP CLAMP

The tank lip clamp is intended for use on floating roof tanks that are constructed in accordance with the API 650 2007 standard, with top angle stiffening rings between 2 1/2" X 2 1/2" X 1/4" to 4" X 4" X 1/2".

Before installing the clamp onto the tank lip, consideration should be given to the desired monitor position (inside or outside the tank), hose lay (hose should be supported as close to the monitor as possible to reduce the load created by the weight of the hose and water on the clamp and monitor), operator position, and the direction the stream will need to point. The monitor should be positioned as close to the clamp jaws as possible to reduce the torque imparted by the reaction force of the stream and the weight of the hose and the water within the hose on the clamp, and ultimately the tank lip itself. Too much torque can damage the clamp and/or the tank.

The clamp arm crank should be turned counterclockwise to ensure it is fully retracted before installing on the tank. The moveable jaw cross-pin will need to be in the closest or next closest backbone cross-hole to the fixed end, depending on the size of the top angle. If the movable jaw is pinned three holes away from the fixed end, the clamp head will not engage the tank lip.

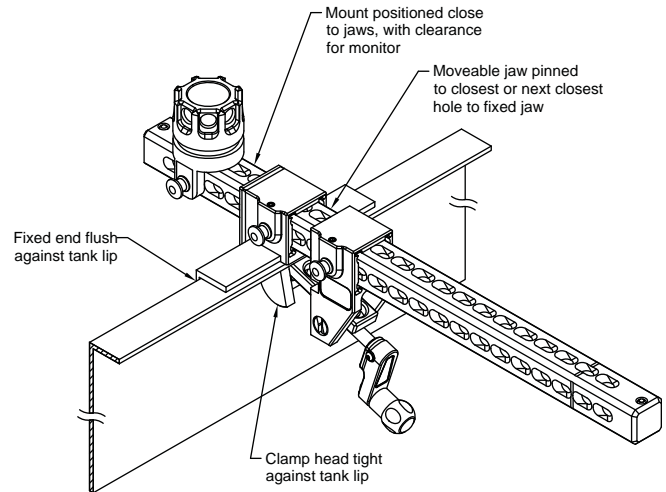

Figure 2.15

With the fixed and movable jaws pinned in their desired positions, slide the backbone/jaw assembly over the tank lip, taking great care not to drop the clamp into or off the side of the tank. While holding the fixed end flush against the tank lip, rotate the crank clockwise until the clamp head is snug against the tank lip. Rotate the crank an additional half-turn until tight.

Install the cross-pin mount on the backbone in the desired position, as close as possible to the jaws without interference between the jaws and/or the tank and the monitor.

Install the monitor on the cross-pin mount in the desired orientation.

2.2.7 PARALLEL BAR CLAMP

The parallel bar clamp is intended for use on a pair of round parallel bars between 1.5" to 2.0" diameter, spaced between 5" to 29" apart, on center. Care must be taken to ensure that the bars are strong enough, and have adequate support, to support the reaction force of the water, the weight of the monitor, clamp, hose, water, and any attachments. For example, an OSHA standard hand rail may only be required to support 200 lbs in any direction, while the reaction force alone created by this monitor can exceed 350 lbs. The cross-pin mount should be positioned either between the bars or as close to one of them as possible, to minimize the amount of torque on the bars. Also, the load on the bars will increase, the closer they are together.

To install the parallel bar clamp, first make sure that all four knobs are fully retracted by turning them counter clockwise until they reach their travel stops. Next, line up the fixed bar clamp with a backbone hole, and secure it to the backbone with the cross-pin.

Open both clamshells and position the fixed bar clamp over a parallel bar. Close both clamshells, latch the eye bolts over the arms, and turn the knobs clockwise until snug.

Slide the floating bar clamp into position over the second parallel bar and attach it the same way as the first bar.

Turn all four knobs an additional quarter turn to ensure they are secure.

Install the cross-pin mount base in the desired position on the backbone and install the monitor.

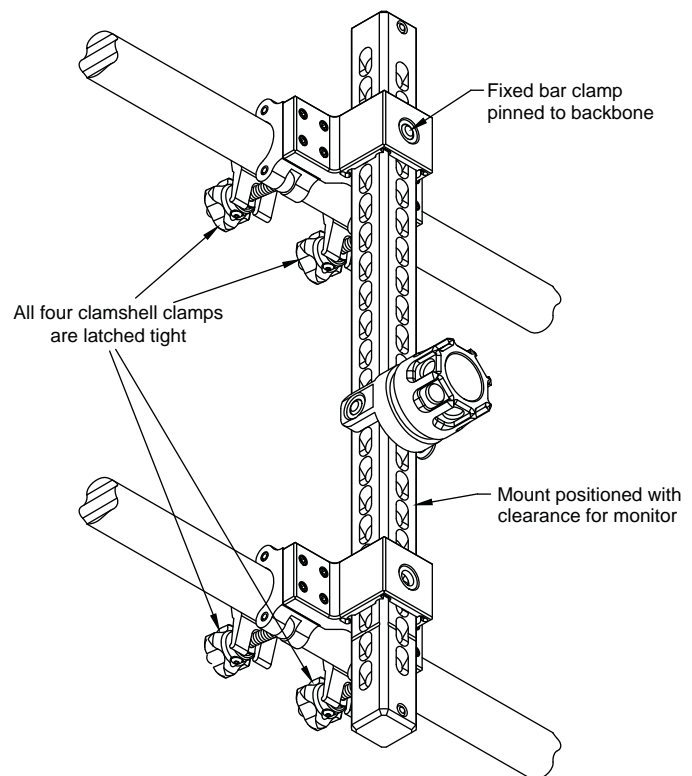

Figure 2.16

2.2.8 FLEX CLAMP

The flex clamp can be used on a variety of different objects. Round objects between 3" to up to 24" diameter can be attached to using the chain supplied with the unit. Larger diameter round objects can be attached to by adding additional chain. Objects with different shaped cross sections can be attached to also, provided there are no sharp edges that the chain must lay against.

2.2.8.1 CHAIN SAFETY

⚠ WARNING Chain strength can be reduced when damaged or corroded. Degraded chain can break, causing property damage and/or bodily harm. Inspect the chain and shackles before and after each use. Refer to section 2.2.8.4 for chain and shackle inspection criteria.

⚠ WARNING Installing chain on objects with sharp corners can bend the chain. Bent chain has less strength and could break, causing property damage and/or bodily harm. Refer to section 2.2.8.3 for minimum radius gaging instructions.

⚠ WARNING Using a cheater bar or other such device to turn the chain tensioner crank can damage the clamp. A damaged clamp can fail, causing property damage and/or bodily harm. Never use a cheater bar or other such device to turn the chain tensioner crank.

⚠ WARNING High temperatures reduce the safe working load of the chain and may result in an unsafe condition. If chain is exposed to temperatures of 400° F [204° C] or higher, remove the clamp from service and replace the chain.

2.2.8.2 CHAIN BENDING



Figure 2.17 Avoid bending chain on corners

The chain will bend and be weakened if it is tightened against a sharp edge (see figure 2.17). An example of an object that can bend the chain would be an unprotected I-beam. The sharp edges at the ends of the flanges push against chain links and bend them. The I-beam clamp (HPM-A) should be used on unprotected I-beams. Other examples of objects that can bend chain are L or C channel, square or rectangular bars with sharp corners, guard rails, flat plates, and brick. Steel corner protectors designed specifically for use with chain can be used on objects with sharp edges, but they can make installation difficult.

2.2.8.3 MINIMUM BEND RADIUS REQUIREMENT

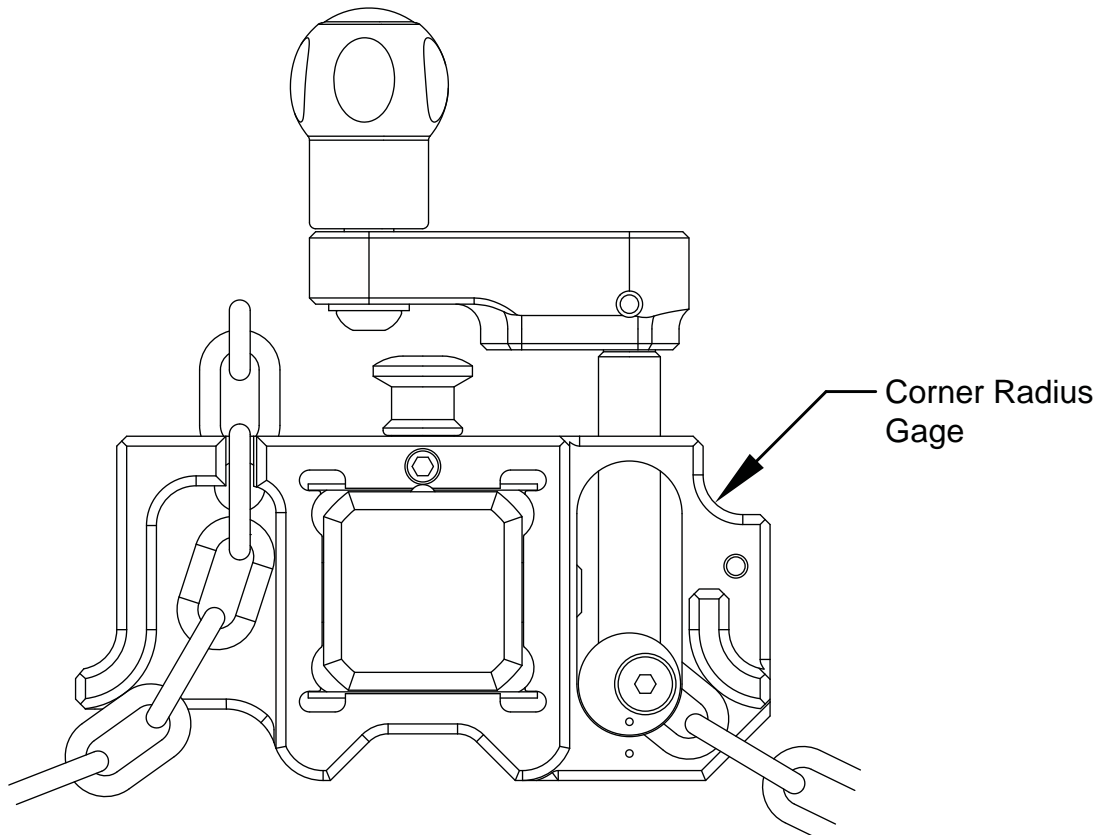

Figure 2.18 Corner radius gage

The minimum corner radius required to avoid bent chain is 3/8" [9.5mm]. To check a questionable corner radius, place the integrated radius gage against the corner, as shown in figure 3.3.

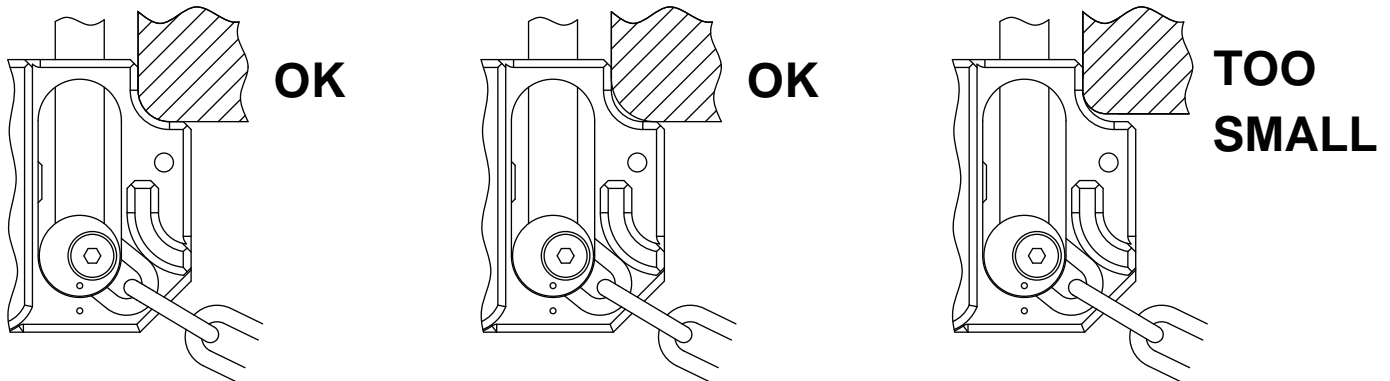

Figure 2.19 Reading the corner radius gage

If the corner radius is smaller than the gage, the clamp should not be used without corner protection.

2.2.8.4 CHAIN AND SHACKLE INSPECTION

Chain and/or shackles are considered damaged and should be replaced if any of the following are observed:

- Wear
- Defective or separated welds
- Nicks, cracks, breaks, gouges, stretch, bends
- Discoloration due to excessive heat
- Excessive pitting or corrosion
- Stripped or damaged threads
- Other conditions that cause doubt as to continued safe use

If the chain is damaged, the clamp should be removed from service and the chain replaced. Use only TFT supplied or equivalent ASTM A413 certified 3/16" [5.5 mm] grade 30 proof coil chain.

2.2.8.5 FLEX CLAMP INSTALLATION

Read and understand sections 2.2.8.1 through 2.2.8.4 of this manual before proceeding with installation. In addition to complying with the minimum bend radius requirements, any mounted object must be capable of withstanding the forces and moments created by the weight of the monitor, attachments, water, and the reaction forces at the nozzle.

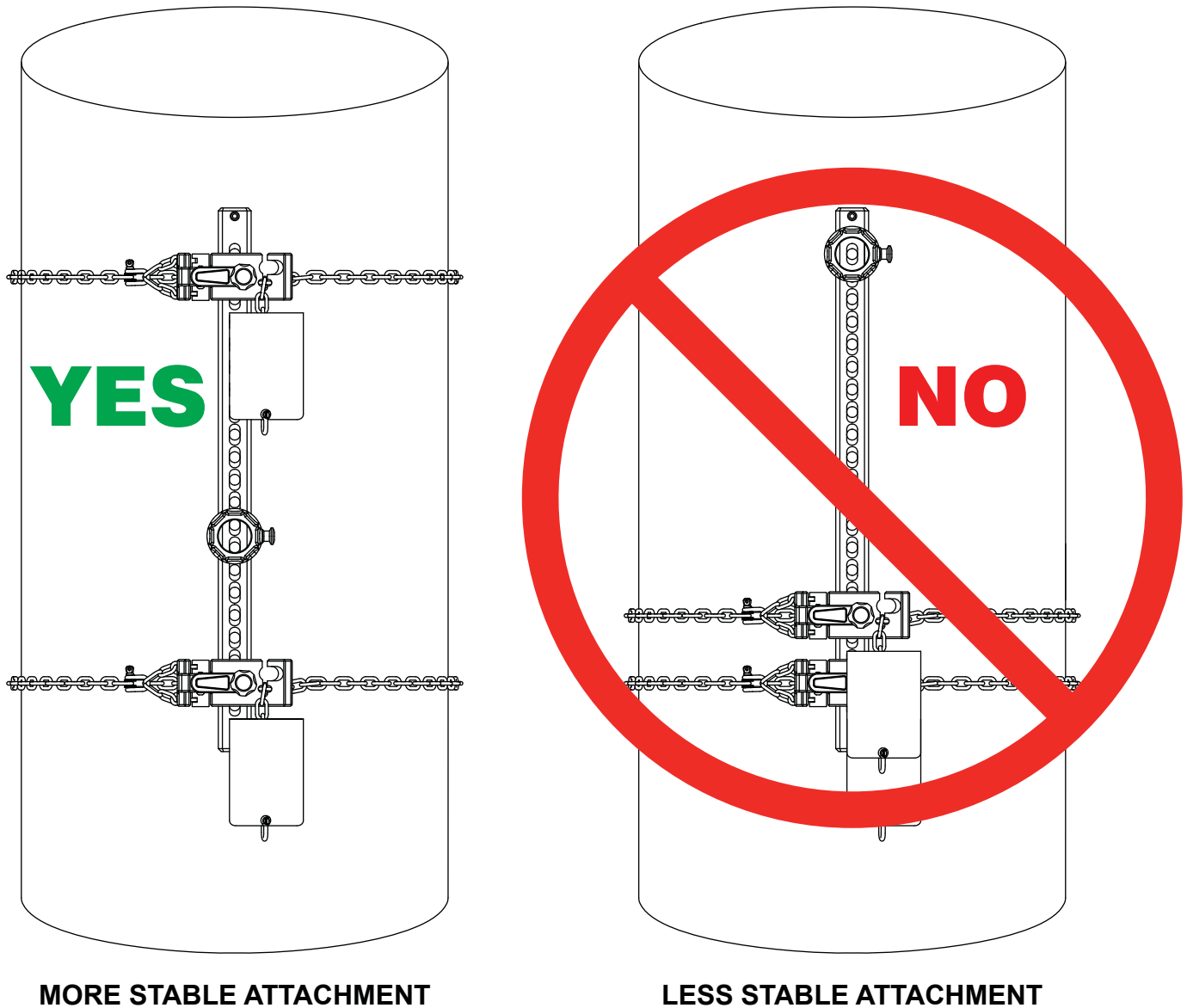

Figure 2.20 Chain and monitor placement for stability

The forces on the chain, and the likelihood of it slipping or breaking, will increase the closer together the chain blocks are, and the further the monitor is from the chain blocks. The most stable configuration is when the chain blocks are at opposite ends of the backbone and the monitor is centered between them. The least stable configuration is when the two chain blocks are as close as they can get to each other at one end of the backbone and the monitor is at the opposite end.

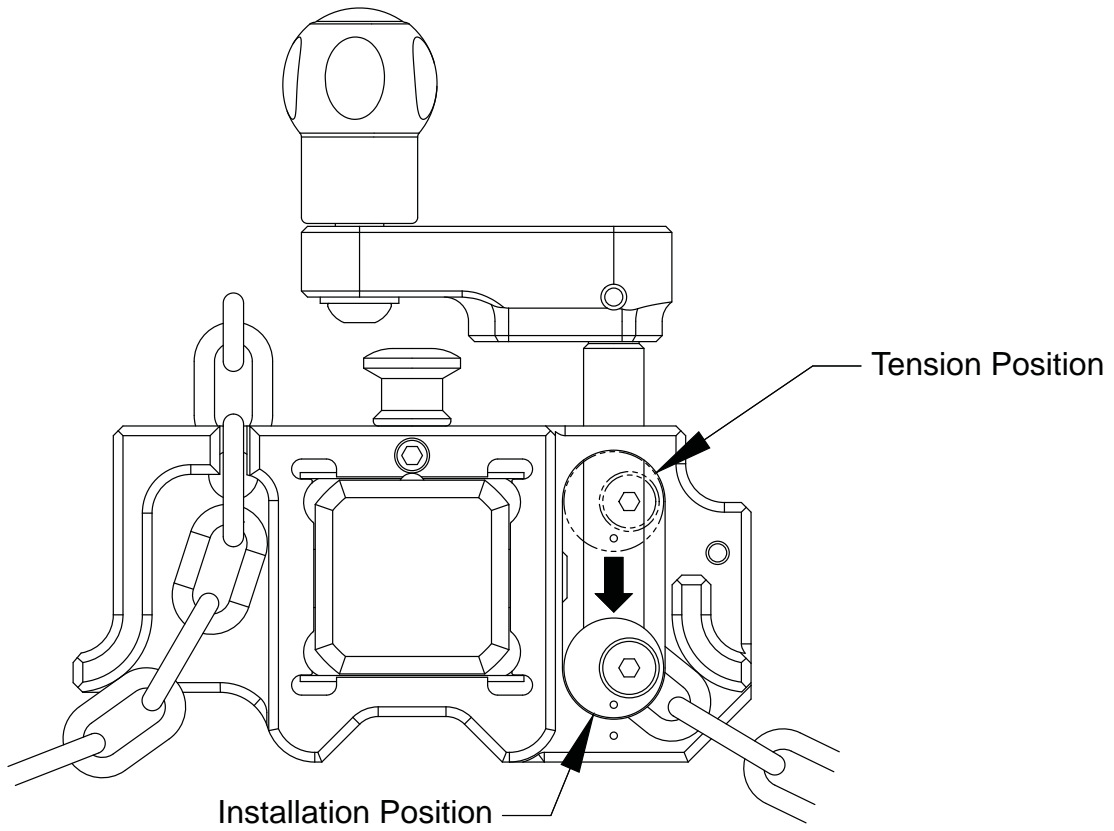

Figure 2.21 Chain tensioner in installation position

Step 1: Verify that the chain tensioners are in the installation position by rotating the crank counterclockwise until the chain tensioner stops at the bottom.

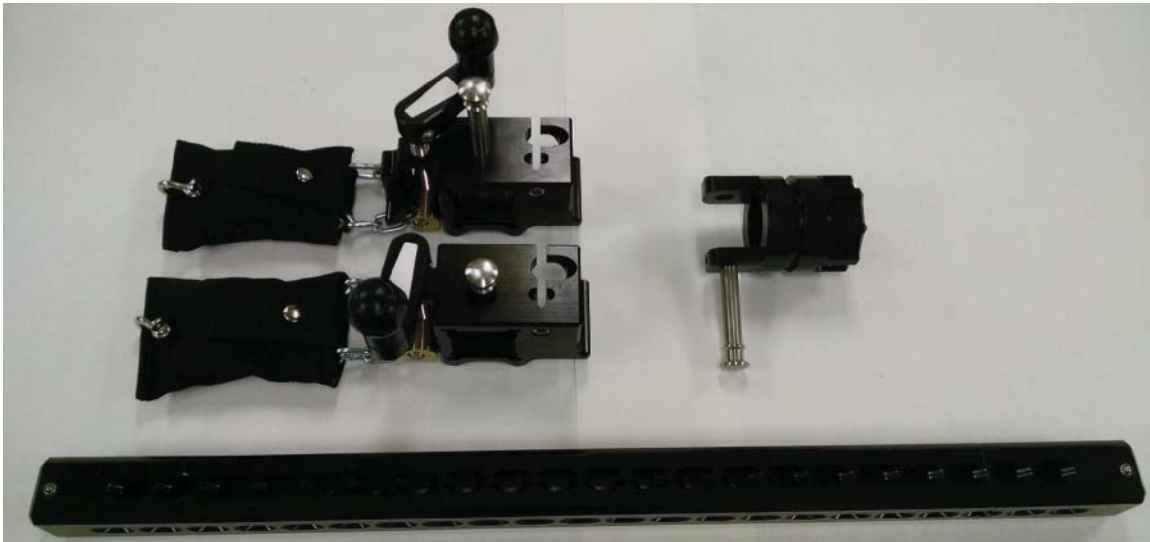

Figure 2.22 Components removed from backbone for installation

Step 2: Separate the chain blocks from the backbone. Separate the cross-pin mount from the backbone.

Step 2: Separate the chain blocks from the backbone. Separate the cross-pin mount from the backbone.



Figure 2.23 Chain released from bag and inspected

Step 3: Release the chain from the bags by unlatching the bag strap. Inspect the chain and verify that it is not twisted, knotted, kinked, or damaged (See section 2.2.8.4.)

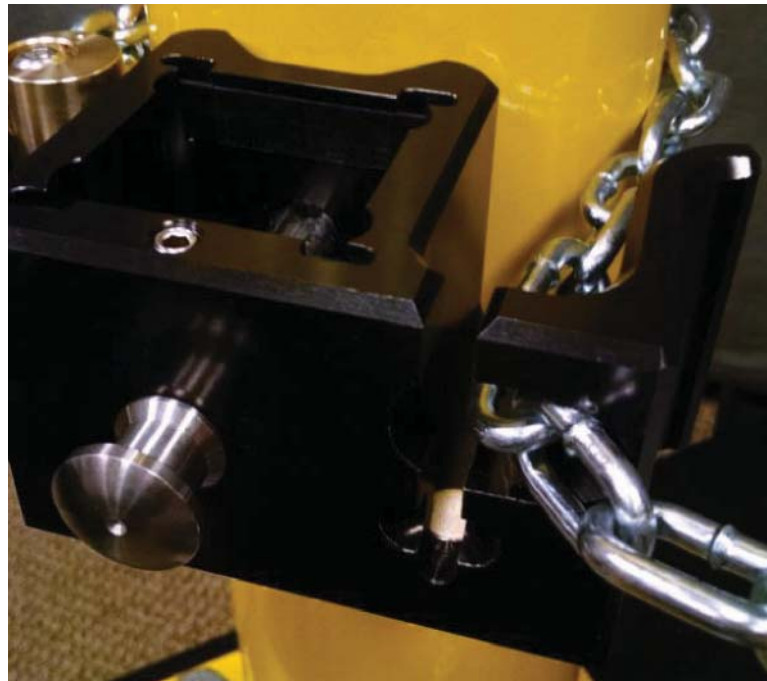

Figure 2.24 Chain in the slack take-up slot

Step 4: Wrap the chain around the object and slide it into the slack take-up slot. Pull the chain tight.

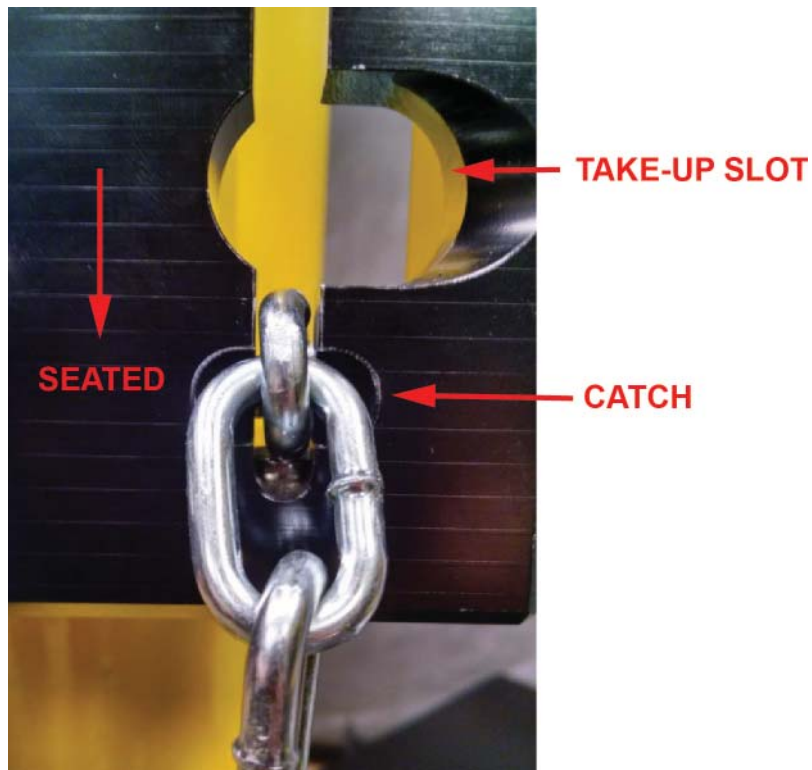

Figure 2.25 Chain seated in the catch

Step 5: Slide the link into the catch. A magnet pulls the chain into the catch. Verify that the chain is secure in the catch.

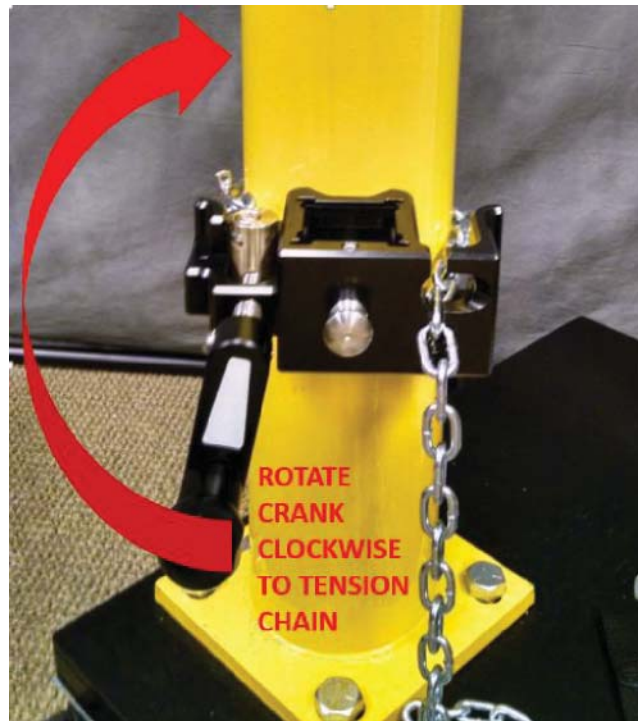

Figure 2.26 Tensioning the chain

Step 6: With the pull pin engaged, rotate the crank clockwise to tension the chain. Double check that the chain is laid straight and secure.

Step 7: Slide the pull pin out. Slide the backbone into the chain block and re-engage the pull pin through the desired hole in the backbone.

Step 8: Slide the second chain block onto the backbone and engage the pull pin in the desired backbone hole. Repeat steps 4 through 6.

Step 9: Align the cross-pin mount with the desired hole position on the backbone and engage the cross-pin.

Step 10: Verify that all cross-pins are fully engaged, chains are tight; and attempt to shake the clamp. Tighten and secure, if necessary. The clamp is now ready for Hemisphere monitor attachment.

Un-installation is the reverse of installation



Figure 2.28 Install the backbone



Figure 2.29 Install the other chain block



Figure 2.30 Install the cross-pin mount

⚠ WARNING

Do not release pull-pins without supporting the load the pull-pin is securing. Under no circumstance should any pull-pin be removed while flowing the monitor. Removing pull-pins without securing the backbone will result in a falling backbone.

2.2.8.6 ADDING CHAIN FOR LARGER OBJECTS

Chain can be added by attaching ASTM A413 certified 3/16" [5.5 mm] zinc plated steel grade 30 proof coil chain to the extender shackle (see Figure 2.4.) Chain can be obtained from TFT. Chain should be inspected per section 3 prior to use.

2.3 INSTALLING THE MONITOR ONTO THE MOUNT

The Hemisphere monitor is designed to be installed by one person, with minimal effort, by sliding the socket at the base of the monitor onto a mount. The monitor is not attached until the monitor release pin seats in the annular groove on the lower portion of the mount. **Attachment should always be verified by attempting to pull the monitor off the mount.** It is recommended that the mount be in place and secured before attaching the monitor. The monitor can be installed with or without a hose attached, but it often requires less effort to line up and orient the monitor without an attached hose.

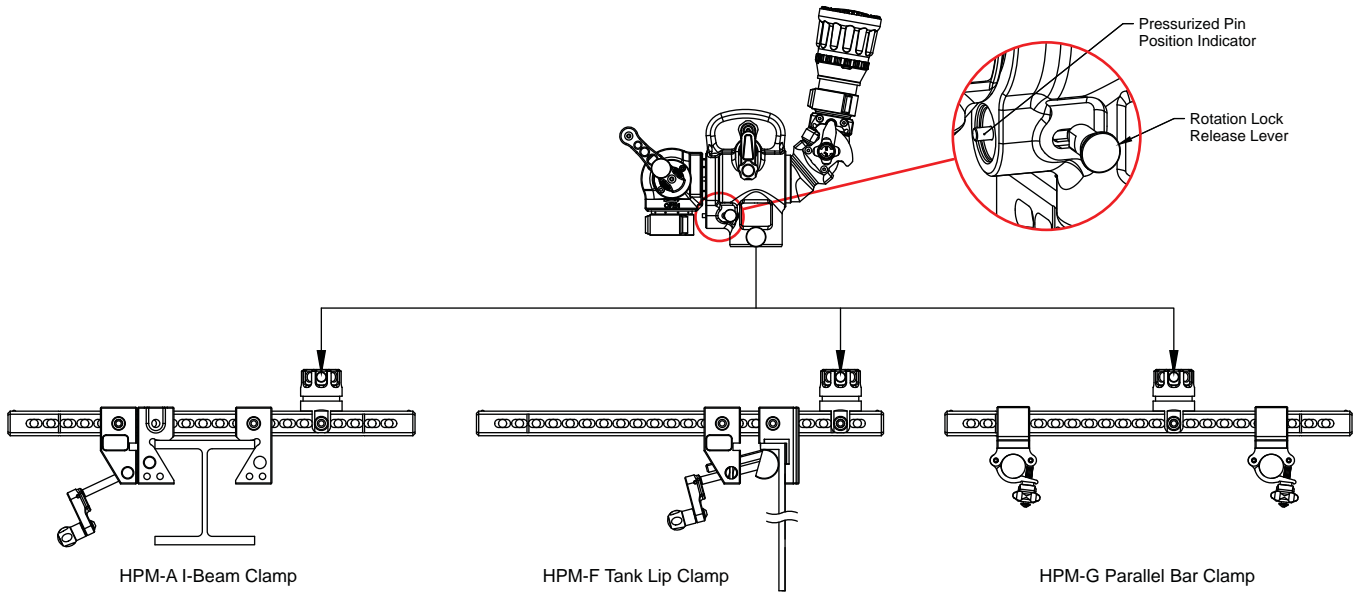

Figure 2.31 Attaching the Monitor to the Mount

2.3.1 RELEASING THE MONITOR FROM THE MOUNT

The monitor release knob retracts the monitor release pin from the annular groove in the mount. It is recommended that the hose be depressurized and removed before releasing the monitor.

2.3.2 PRESSURE GAUGE PORT

There is a 1/8" NPT female threaded hole on the back of the monitor and the exit elbow. The holes are plugged from the factory. If a pressure gauge is desired, unscrew the plug and install the gauge using pipe sealant. Make sure the gauge does not interfere with operation.

⚠️ WARNING

Do not force the rotation lock release lever or attempt to reposition the monitor on it's mount while flowing. Reaction forces generated from the flow of water through this monitor can be as high as 350 lbf (160 kg), and can cause the monitor to become unstable or even out of control if the safety mechanism becomes compromised. To reduce risk of injury or death from an out of control monitor, verify that the safety mechanism is not compromised.

2.3.3 ROTATING THE MONITOR ABOUT THE MOUNT

Once the monitor is secured to the mount, it may be necessary to re-orient the monitor. Rotation lock release levers (see fig. 2.34), on both sides of the monitor, provide the ability to rotate the monitor about it's mount in 45 degree increments, provided the monitor is not flowing. If the rotation lock release lever is pulled while flowing, a pressurized chamber behind the pin prevents it from unlocking.

2.3.4 SAFETY MECHANISM

The hemisphere has a safety mechanism that incorporates a pressure activated component intended to remind the user not to rotate or release the monitor from its base while flowing by making the lever difficult to pull. The safety device is pressure activated to push the rotation lock pin (red) into the holes on the base whenever the monitor is pressurized. Pulling back on the rotation lock release lever with the monitor flowing is dangerous. Although the force required to pull back the rotation lock release lever increases with increased pressure, with enough force, the lever can still be pulled.

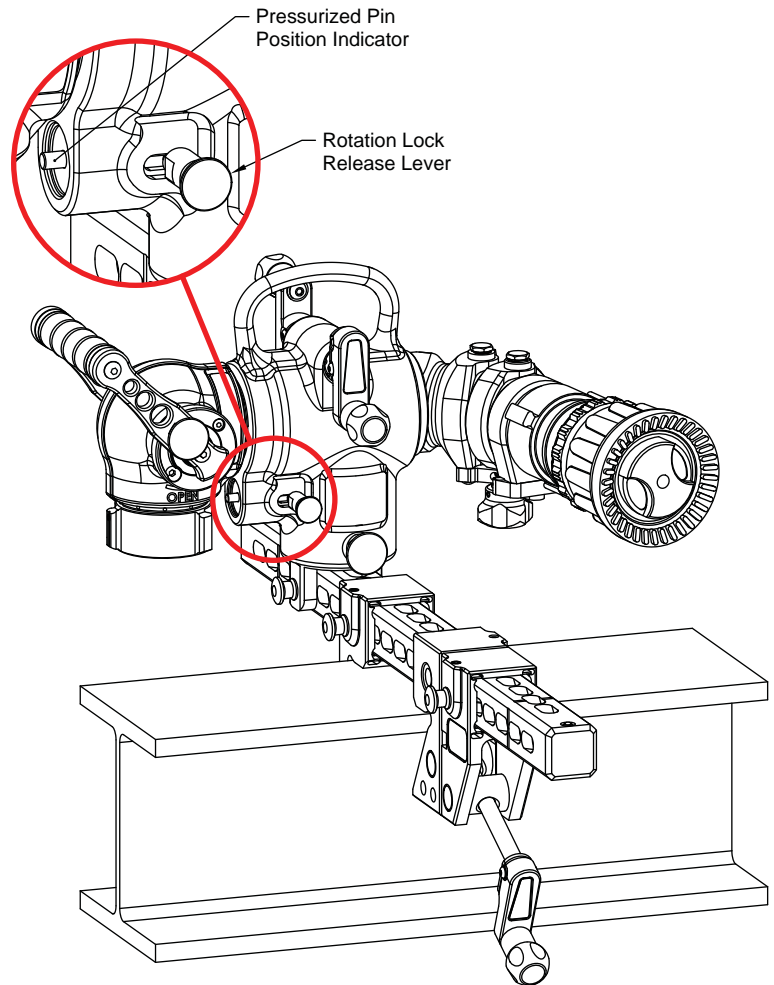

Figure 2.34 Monitor mounted on the backbone showing the position of the lock release lever and indicator pin.

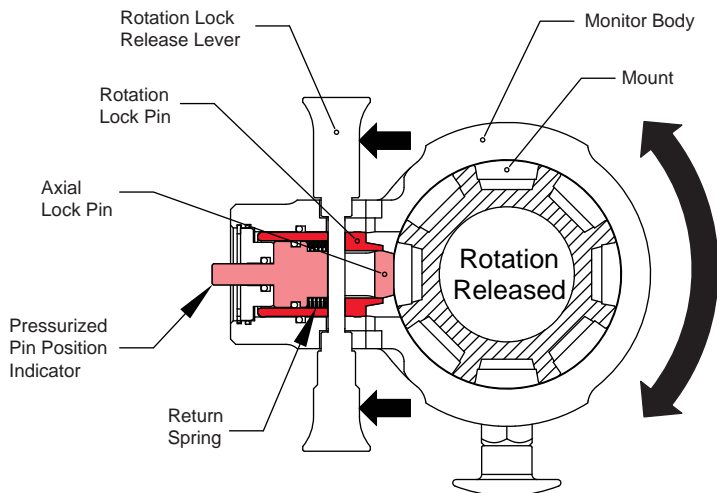

Figure 2.35 Cross-Section Showing Rotation Lock Lever Pulled Back, Allowing the Monitor to Rotate about Its Mount

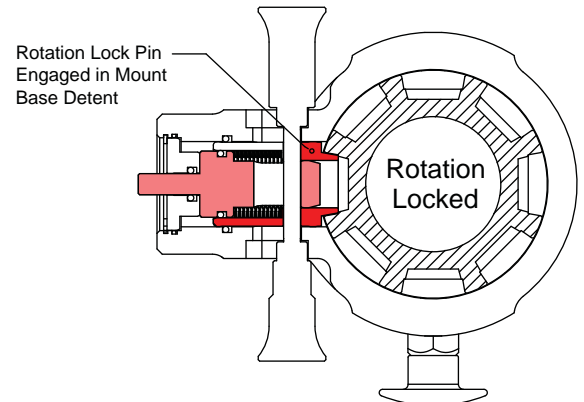

Figure 2.36 Rotation Lock Lever Released; Monitor Cannot Rotate about Its Mount

Figure 2.37 shows the pressurized chamber behind the rotation and axial lock pins when the monitor is flowing. See maintenance section 4.2 for pressurized lock pin maintenance information.

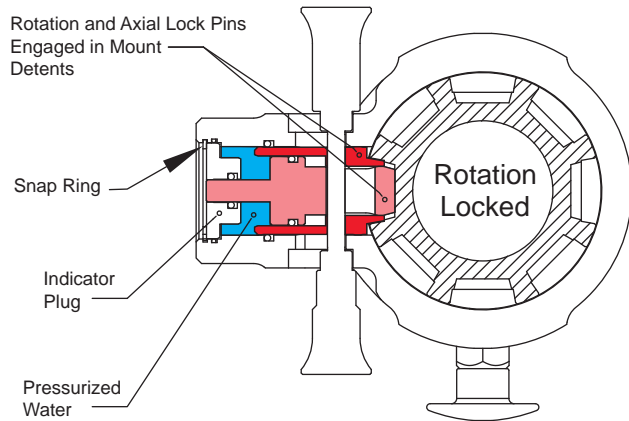

Figure 2.37 Rotation Lock Lever Released; Monitor Flowing; Rotation Lock Lever is Prevented From Being Pulled

2.4 POINTING THE NOZZLE

Once the mount is secured, the monitor is secured to the mount, and the hose is in place, the initial nozzle flow direction must be established. The Hemisphere has a double ball pivot mechanism that incorporates synchronizing geometry to prevent reaction forces from influencing the flow direction. This allows the double ball pivot assembly to provide twice the sweep of a single ball, a full 80 degree range of motion. The double ball pivot is normally loose, and easy to position, without the lock engaged. Additional resistance can be added by turning the lock knob until the desired resistance is achieved. To maintain a fixed position, the lock knob can be tightened all the way down.

In addition to the 80 degrees of sweep provided by the pivoting outlet, the angled waterway, to which the double ball pivot is attached, can be rotated a full 360 degrees with no travel stops.

Additional information about pivoting the outlet can be found in section 2.4.2, and information about rotating the waterway is in 2.4.4.

2.4.1 HEMISPHERE COVERAGE

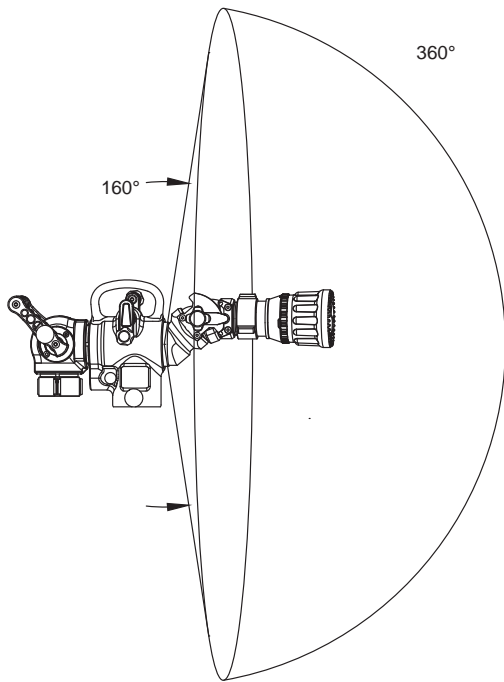

Figure 2.38 Graphic Illustrating the range of possible nozzle orientations, while flowing, combining main waterway rotation, with double ball sweep (water flow does not need to be interrupted to achieve these rotations.)

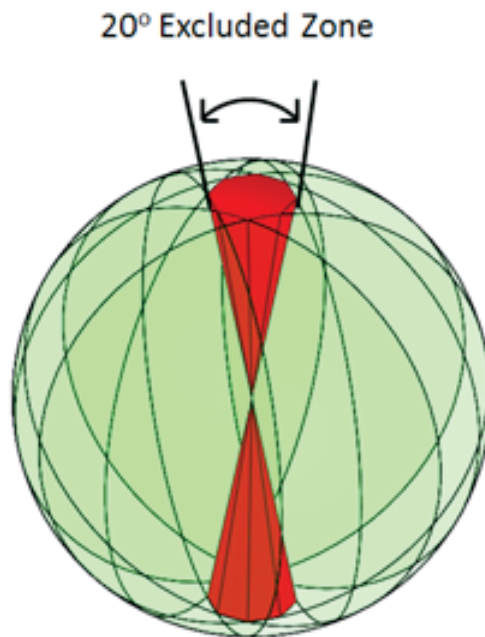

Figure 2.39 Graphic Illustrating the range of possible nozzle orientations, combining main waterway rotation, with double ball sweep, and 45 degree incremental rotations about the monitor base (water flow needs to be interrupted to achieve rotation about the monitor mount)

Figures 2.38 and 2.39 show the range of possible directions the Hemisphere nozzle can point overall, through combined rotations about all of its axes. The range shown in figure 2.38, almost a complete hemisphere, is achievable without interrupting water flow. When that range is rotated about the monitor mount, without water flowing, any point on a sphere, minus the 20 degree regions above and below the monitor, can theoretically be achieved, as illustrated in Fig. 2.39. In practice, however, some regions will be obscured by the mount and/or mounted object.

2.4.2 PIVOTING THE OUTLET

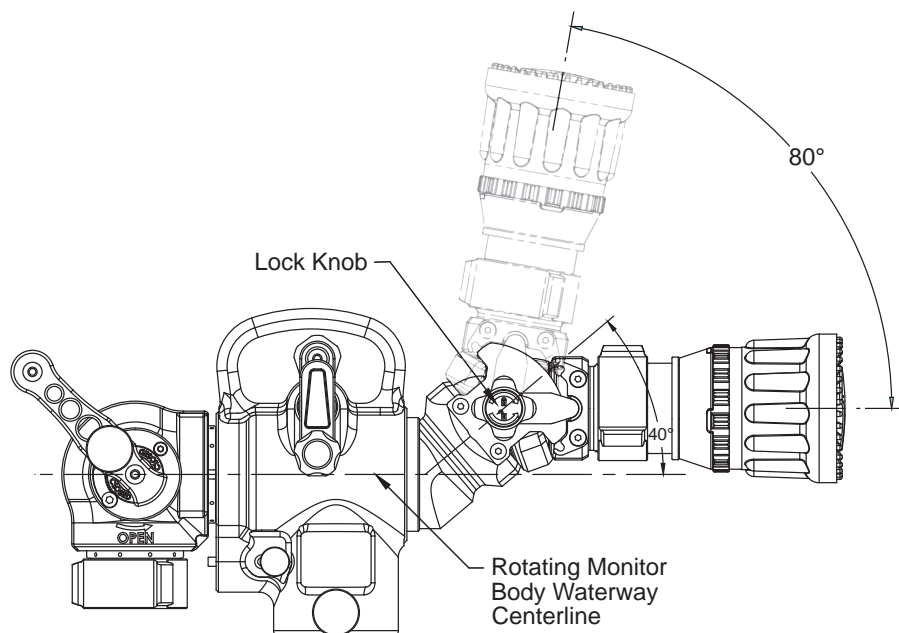

Figure 2.40 Double ball pivot orientation and range of motion.

The outlet is preceded by a double ball pivot that incorporates a synchronizing mechanism. Each pivot is capable of 40 degrees of rotation, resulting in a total of 80 degrees of sweep (see Fig. 2.40.) The 80 degree sweep is centered 40 degrees from the rotating monitor body waterway centerline, allowing the outlet to point parallel to the monitor body waterway centerline, and up to 80 degrees away from the centerline.

The synchronizing mechanism allows the pivot nearest the outlet to be pointed off of the axis of the pivot nearest the monitor body by taking up the part of the reaction force that would tend to rotate the pivot nearest the monitor body.

See section 4.1 for synchronizer maintenance and wear pad repair/replacement information

2.4.3 LOCKING THE OUTLET PIVOTS

Lock the trajectory in position while flowing by hand tightening the lock knob clockwise. Don't use a wrench, tool or cheater bar.

2.4.4 ROTATING THE WATERWAY

The waterway through the monitor body is attached to a double crank shaft by a worm gear, and can be rotated a full 360 degrees. The crank arms come in a standard configuration where the holes closest to the knobs attach to the shaft, and the two crank arms are rotated 180 degrees to each other. The force required to rotate the crank can be reduced by removing the screws holding the crank arm, and moving the crank shaft from the bore closest to the knob to the bore furthest from the knob. Either of the crank arms can also be rotated 180 degrees to make both cranks aligned, if preferred.

2.4.5 QUARTER TURN VALVE

⚠ WARNING Quick changes in valve position can cause high pressure spikes due to water hammer and may result in damaged equipment which could lead to injury or death. Open and close the valve slowly to avoid water hammer.

⚠ WARNING Kinks in supply hose may reduce water flow and cause injury or death to persons dependant on water flow. Avoid tight bends to minimize risk of hoseline kinks.

The quarter turn valve incorporates a bail style handle to allow opening/closing from either side. The valve locks in the off position to prevent accidental opening. The valve also includes an internal mechanism that prevents the force of the water from influencing the valve position. See LIA-355 2.5" Quarter Turn Hydrant Valve Manual for more information.

3.0 FLOWS AND PRESSURES

The Hemisphere Transportable Monitor is designed for maximum flows of 500 GPM (2000 LPM) and a maximum pressure at the nozzle, while flowing of 175 PSI (12 BAR). Do not exceed these limits.

⚠ WARNING An inadequate supply of pressure and/or flow will cause an ineffective stream and can result in injury, death or loss of property.

⚠ WARNING The monitor may be damaged if frozen while containing sufficient amounts of water. Such damage may be difficult to detect visually and can lead to possible injury or death. Any time the monitor is subject to possible damage from freezing, it must be hydrostatically tested by qualified personnel before being considered safe for use.

3.1 AUTOMATIC, FIXED, AND SELECTABLE FLOW NOZZLES

A variety of water or foam nozzles may be used with the Hemisphere. Automatic nozzles maintain a constant pressure by adjusting their opening to match the available flow. Consult the nozzle manufacturer for maximum flow and pressure ratings. In all cases do not exceed 500 GPM (2000 LPM) and/or 175 PSI (12 BAR) nozzle exit pressure.

3.2 STACKED TIPS OR SMOOTHBORE NOZZLES

NOZZLE DIAMETER	NOZZLE EXIT PRESSURE									
	50 PSI		80 PSI		100 PSI		150 PSI		175 PSI	
	FLOW (GPM)	REACTION (LBS)	FLOW (GPM)	REACTION (LBS)	FLOW (GPM)	REACTION (LBS)	FLOW (GPM)	REACTION (LBS)	FLOW (GPM)	REACTION (LBS)
1.0 INCH	210	80	266	126	297	157	364	236	390	275
1-1/4 INCH	328	120	415	196	464	245	—	—	—	—
1-1/2 INCH	473	177	—	—	—	—	—	—	—	—

NOZZLE DIAMETER	NOZZLE EXIT PRESSURE									
	4 BAR		6 BAR		8 BAR		10 BAR		12 BAR	
	FLOW (L/min)	REACTION (KG)	FLOW (L/min)	REACTION (KG)	FLOW (L/min)	REACTION (KG)	FLOW (L/min)	REACTION (KG)	FLOW (L/min)	REACTION (KG)
25 MM	830	40	1000	60	1200	80	1300	100	1400	120
32 MM	1300	70	1700	100	1900	130	—	—	—	—
38 MM	1900	90	—	—	—	—	—	—	—	—

 FLOW EXCEEDS RATING OF HEMISPHERE TRANSPORTABLE MONITOR

3.3 STREAM STRAIGHTENERS

Stream quality, especially with smooth bore nozzles, is generally improved with the use of a stream straightener. A stream straightener is integrated into the exit of the monitor.

3.4 USE WITH FOAM

The Hemisphere may be used with various foam nozzles and foam solutions. Refer to fire service training for the proper use of foam.

3.5 USE WITH SALT WATER

Use with salt water is permissible provided the monitor is thoroughly cleaned with fresh water after each use. The service life of the monitor may be shortened due to the effects of corrosion and is not covered under warranty.

3.6 HEMISPHERE PRESSURE LOSS

Figure 3.6 gives the pressure loss for the Hemisphere Transportable Monitor

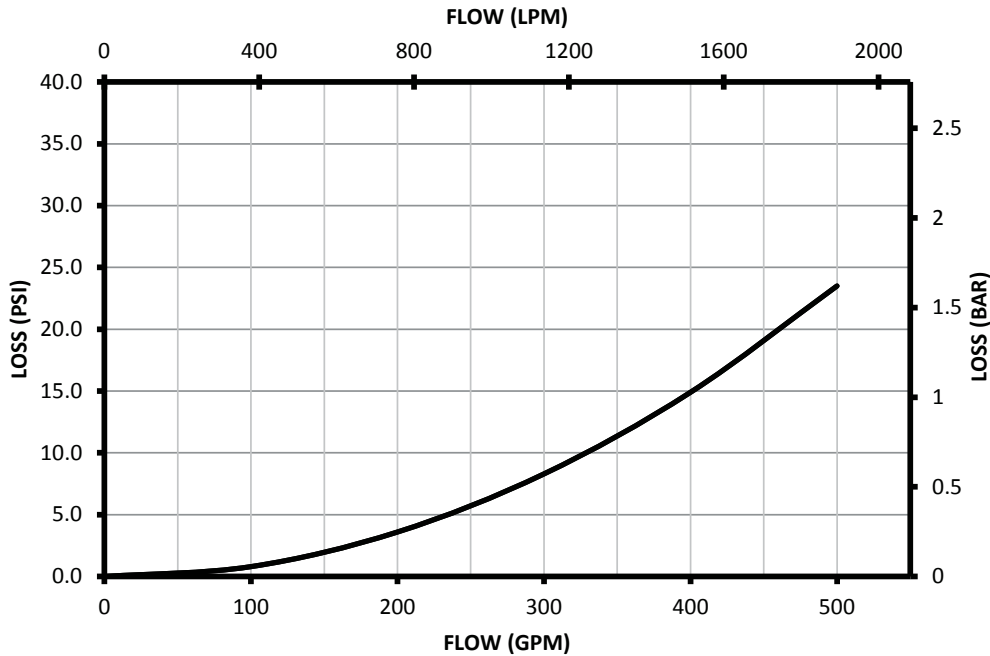

Figure 3.6 Hemisphere Pressure Loss

3.7 HEMISPHERE OPERATING ENVELOPE

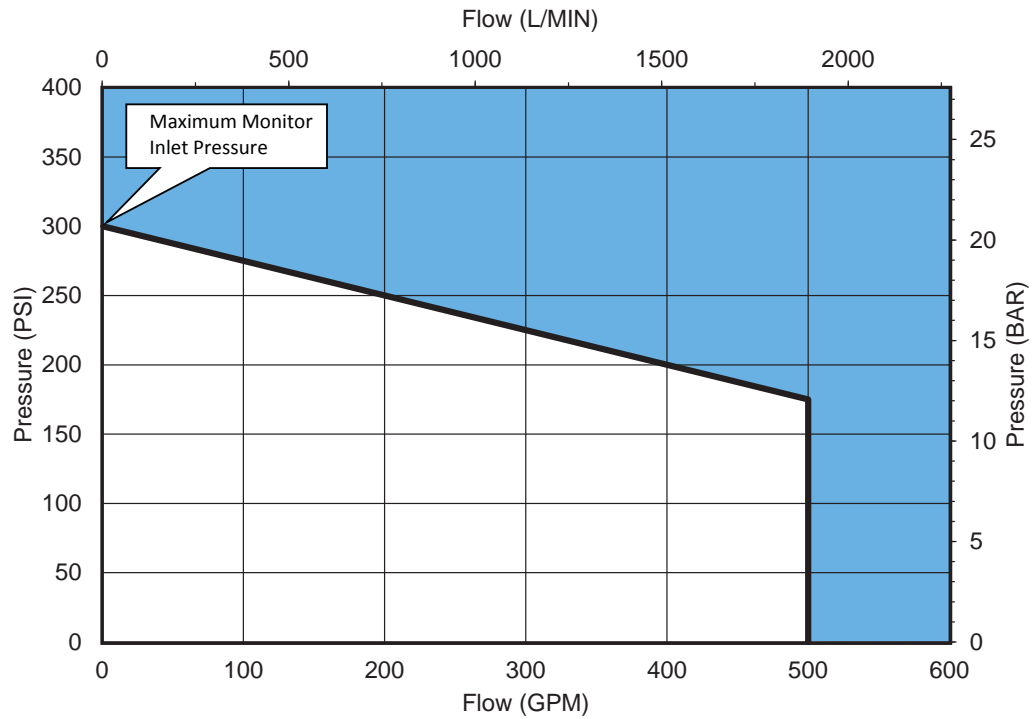

Figure 3.7 Hemisphere Operating Envelope

4.0 EXPLODED VIEWS AND PARTS LISTS

4.1 HEMISPHERE MONITOR EXPLODED VIEW & PARTS LIST

4.2 DOUBLE BALL SWIVEL EXPLODED VIEW & PARTS LIST

4.3 I-BEAM CLAMP EXPLODED VIEW & PARTS LIST

4.4 TANK LIP CLAMP EXPLODED VIEW AND PARTS LIST

4.5 PARALLEL BAR CLAMP EXPLODED VIEW AND PARTS LIST

4.1 HEMISPHERE MONITOR EXPLODED VIEW & PARTS LIST

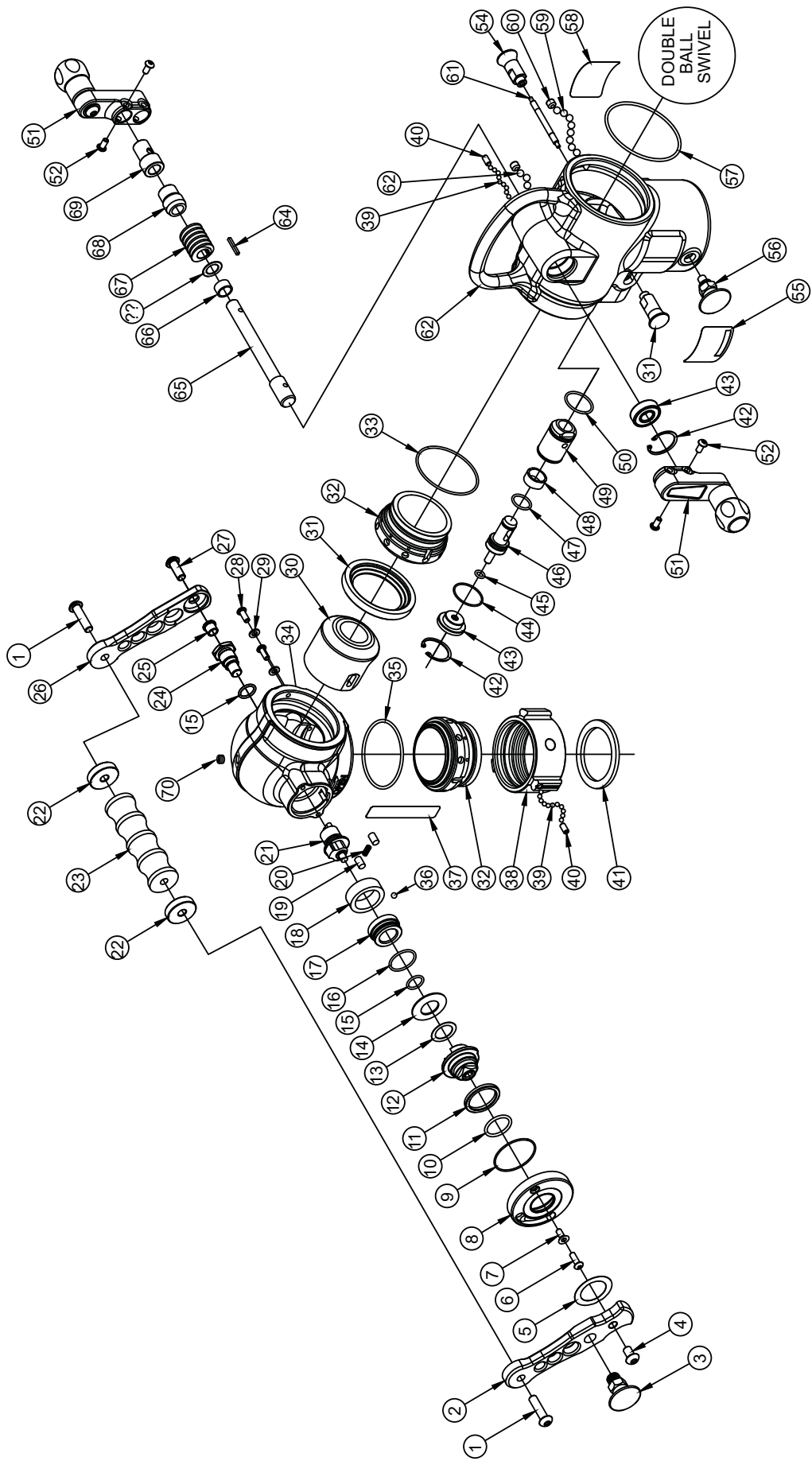

#	DESCRIPTION	QTY.	PART #
1	3/8-16 X 1-1/2 BUTTON HEAD SCREW	2	VT37-16BH1.5
2	DRIVE ARM	1	HE117
3	PULL PIN SUBASSEMBLY	1	HE805
4	3/8-16 X 1 BUTTON HEAD SCREW	1	VT37-16BH1.0
5	OPEN/CLOSE LABEL	1	HE191
6	1/4-20 X 3/4 BUTTON HEAD SCREW	1	VT25-20BH750
7	1/4-20 X 1/2 FLAT HEAD SCREW	1	VT25-20FH500
8	TRUNNION RETAINER	1	HE110
9	O-RING-033	1	VO-033
10	O-RING-216	1	VO-216
11	BUSHING	1	AY324
12	UPPER TRUNNION	1	HE109
13	WASHER	1	G636-020
14	BELLEVILLE SPRING	1	AY325
15	O-RING-115	2	VO-115
16	O-RING-123	1	VO-123
17	INNER BUSHING	1	HE351
18	FLOATING RING	1	AY352
19	DOWEL PIN	2	VP312X.50
20	CONTACT SPRING	1	HC115
21	INNER UPPER TRUNNION	1	AY350
22	BUSHING	2	HE131
23	HANDLE TOP	1	XX625
24	LOWER TRUNNION	1	HE353
25	FLANGED SLEEVE BEARING	1	HE152
26	FLOATING ARM	1	HE118
27	3/8-16 X 5/8 BUTTON HEAD SCREW	1	VT37-16BH625
28	1/4-20 X 5/8 BUTTON HEAD SCREW	2	VT25-20BH625
29	WASHER	2	VW500X265-63
30	HEMISPHERE VALVE	1	HE310
31	VALVE SEAT	1	AY315
32	SIDE B ADAPTER HSBGM30	2	AY365
33	O-RING-151	1	VO-151
34	2.5" GATED ELBOW BODY	1	HE308
35	O-RING-234	1	VO-234
36	1/4" SS BALL	1	V2125

#	DESCRIPTION	QTY.	PART #
37	WARNING LABEL	1	HE193
38	COUPLING 2.5" ROCKERLUG	1	M307*
39	3/16" SS BALLS (48) PER RACE	96	V2120
40	1/4-28 X 1/2 SOCKET SET SCREW	2	VT25-28SS500
41	2.5" GASKET	1	V3190
42	SNAP RING	2	VR4220
43	PLUG	1	HE105
44	O-RING-028	1	VO-028
45	O-RING-109	1	VO-109
46	AXIAL LOCK PIN	1	HE104
47	O-RING-117	1	VO-117
48	WAVE SPRING	1	HE150
49	ROTATIONAL LOCK PIN	1	HE103
50	O-RING-124	1	VO-124
51	CRANK WITH KNOB SUBASSEMBLY	2	A1623
52	1/4-20 X 1/2 BUTTON HEAD SCREW	4	VT25-20BH500
53	BEARING	1	VM4252
54	PIN RETRACT LEVER	2	HE107
55	HEMISPHERE NAME LABEL	1	HE192
56	PULL PIN SUBASSEMBLY	1	HE802
57	O-RING-239	1	VO-239
58	INSTRUCTION LABEL	1	HE194
59	5/16" SS BALL	38	VB.312
60	3/8-24 X 5/16 SOCKET SET SCREW	2	VT37-24SS312
61	PIN RETRACT SHAFT	1	HE106
62	5/16" TORLON BALL	38	VB.312TO
63	BODY	1	HE100
64	KEY	1	X225
65	DRIVE SHAFT	1	HE124
66	SPACER	1	Y4150
67	12 DP WORM	1	X220
68	BUSHING	1	Y3162
69	SHAFT SPACER	1	HE119
70	1/8" NPT PLUG	1	VFSPIM-SS
71	WASHER 18-8 STAINLESS	1	VW938X591-03
* Consult Factory for special threads			

4.2 DOUBLE BALL SWIVEL EXPLODED VIEW & PARTS LIST

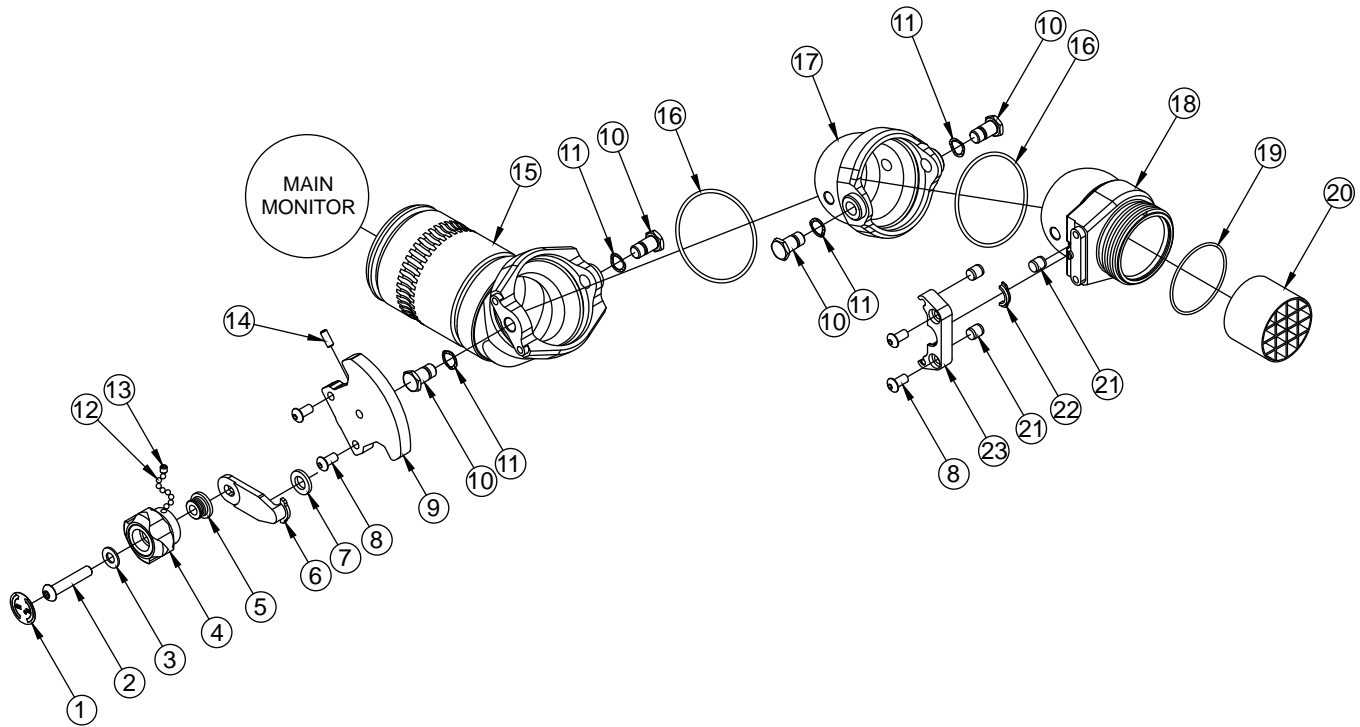

#	DESCRIPTION	QTY.	PART #
1	LOCK/UNLOCK LABEL	1	HE190
2	3/8-16 X 2 BUTTON HEAD SCREW	1	VT37-16BH2.0
3	WASHER	1	VW812X406-65
4	CAM LOCK KNOB	1	HE120
5	KNOB BALL RACE	1	HE123
6	CLAMP LEVER	1	HE125
7	WASHER	1	XX364
8	5/16-18 X 5/8 BUTTON HEAD SCREW	4	VT31-18BH625
9	DOUBLE BALL SWIVEL CAM	1	HE112
10	SWIVEL TRUNNION	4	XX320
11	WAVE SPRING WASHER	4	VW740X550-16
12	3/16" TORLON BALL	12	V2120-TORLON
13	1/4-28 X 1/4 SOCKET SET SCREW	1	VT25-28SS250
14	1/4-20 X 5/8 SOCKET SET SCREW	1	VT25-20SS625
15	ARTICULATING ELBOW/BASE - GLUED	1	HE800
16	O-RING-236	2	VO-236
17	BALL SWIVEL MIDDLE SEGMENT 2.5"	1	HE113
18	BALL SWIVEL OUTLET SEGMENT 2.5"	1	HE114*
19	O-RING-147	1	VO-147
20	STREAM STRAIGHTENER INSERT	1	XXL406
21	CAM LOCK PAD	3	HE121
22	PIVOT COLLAR	1	HE129
23	DOUBLE BALL SWIVEL CAM FOLLOWER	1	HE116
* - CONSULT FACTORY FOR SPECIAL THREADS			

4.3 I-BEAM CLAMP EXPLODED VIEW & PARTS LIST

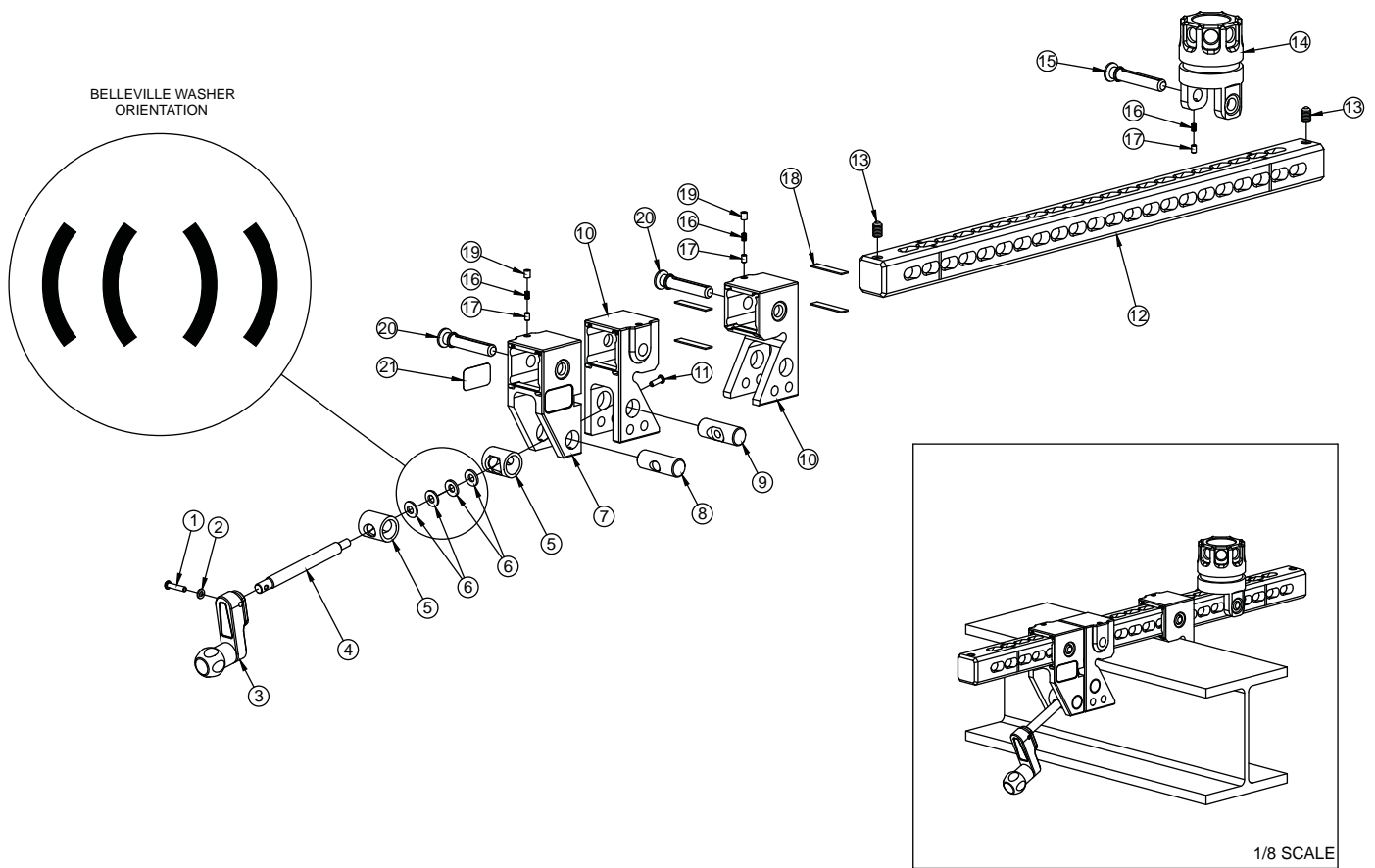

#	DESCRIPTION	QTY.	PART #
1	1/4-20 X 1 1/4 BUTTON HEAD SCREW	1	VT25-20BH1.2
2	WASHER	1	VW500X265-63
3	CRANK WITH KNOB SUBASSEMBLY	1	HE803
4	5/8" THREADED ROD	1	HE176
5	PIN RETAINER	2	HE187
6	BELLEVILLE WASHER	4	VM4904
7	CLAMP SLIDE	1	HE183
8	FIXED ADJUSTMENT PIVOT	1	HE185
9	ADJUSTER PIVOT	1	HE184
10	CLAMP JAW	2	HE182
11	1/4-20 X 3/4 BUTTON HEAD SCREW	1	VT25-20BH750
12	MOUNTING CLAMP BACKBONE	1	HE160
13	PLUNGER	2	XXL505
14	CLAMP MOUNTING BASE	1	HE102A
15	CAPTURED MOUNTING PIN	1	HE178
16	DETENT SPRING	3	HM770
17	LATCH PIN	3	HE175
18	WEAR STRIP	12	HE134
19	5/16-18 X 3/8 SOCKET SET SCREW	2	VT31-18SS375
20	CAPTURED BLOCK PIN	2	HE188
21	TASK FORCE TIPS LOGO LABEL (1) PER SIDE	2	HE195

4.4 TANK LIP CLAMP EXPLODED VIEW AND PARTS LIST

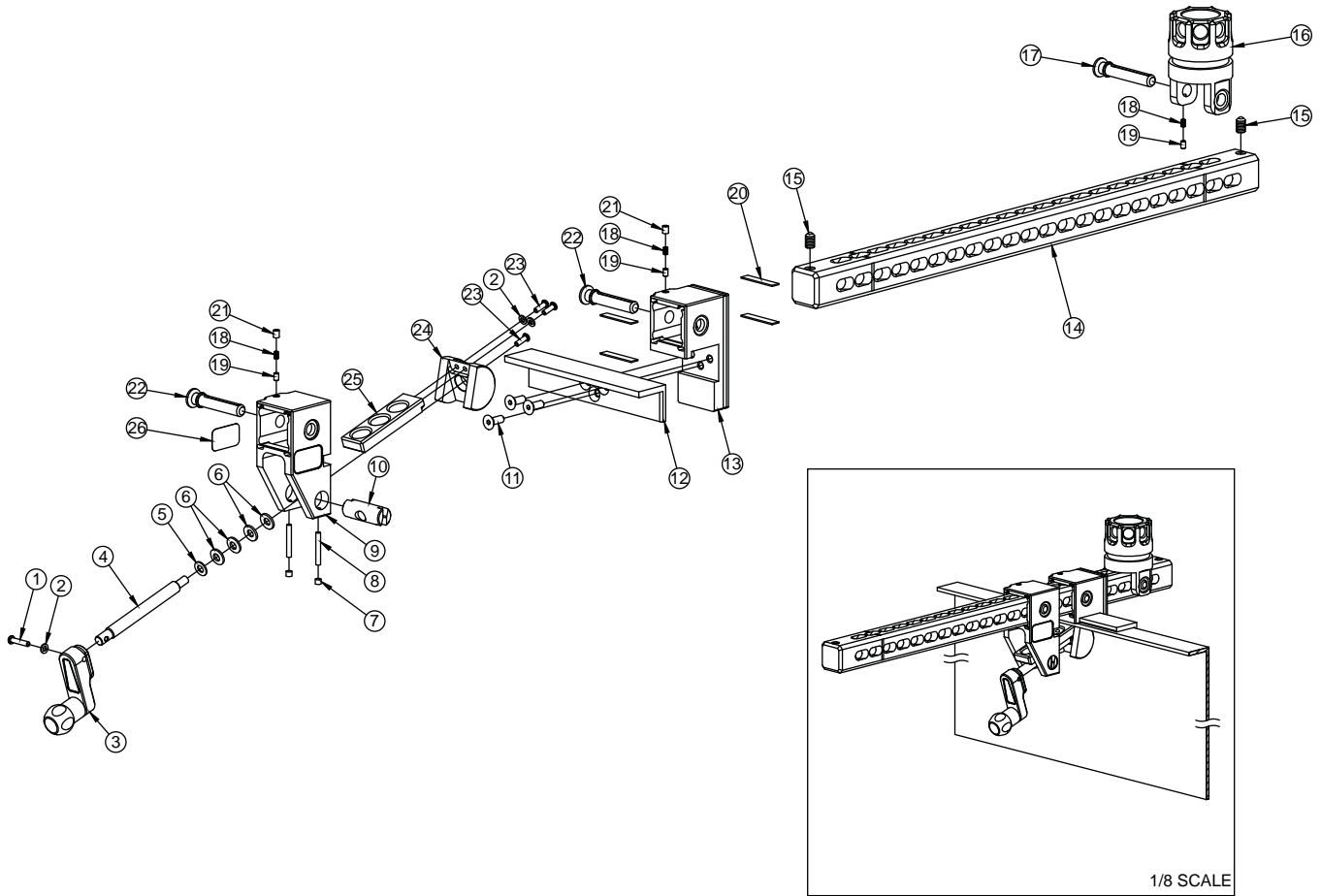

#	DESCRIPTION	QTY.	PART #
1	1/4-20 X 1.25 BUTTON HEAD SCREW	1	VT25-20BH1.2
2	WASHER	3	VW500X265-63
3	CRANK WITH KNOB SUBASSEMBLY	1	HE803
4	5/8" THREADED ROD	1	HE176
5	WASHER	1	VW812X406-65
6	BELLEVILLE WASHER	4	VM4904
7	5/16-18 X 1/4 SOCKET SET SCREW	2	VT31-18SS250
8	1/4 X 3/4 DOWEL PIN	2	VP250X.750
9	CLAMP SLIDE	1	HE183
10	FIXED ADJUSTMENT PIVOT	1	HE133
11	3/8-16 X 1 FLAT HEAD SCREW	3	VT37-16FH1.0
12	ANGLE JAW	1	HE179
13	TANK LIP CLAMP FIXED END	1	HE189

#	DESCRIPTION	QTY.	PART #
14	MOUNTING CLAMP BACKBONE	1	HE160
15	PLUNGER	2	XL505
16	CLAMP MOUNTING BASE	1	HE102A
17	CAPTURED MOUNTING PIN	1	HE178
18	DETENT SPRING	3	HM770
19	LATCH PIN	3	HE175
20	WEAR STRIP	8	HE134
21	5/16-18 X 3/8 SOCKET SET SCREW	2	VT31-18SS375
22	CAPTURED BLOCK PIN	2	HE188
23	1/4-20 X 3/4 BUTTON HEAD SCREW	3	VT25-20BH750
24	TANK LIP CLAMP HEAD	1	HE186
25	GUIDE BLOCK	1	HE132
26	TASK FORCE TIPS LOGO LABEL	2	HE195

4.6 FLEX CLAMP EXPLODED VIEW AND PARTS LIST

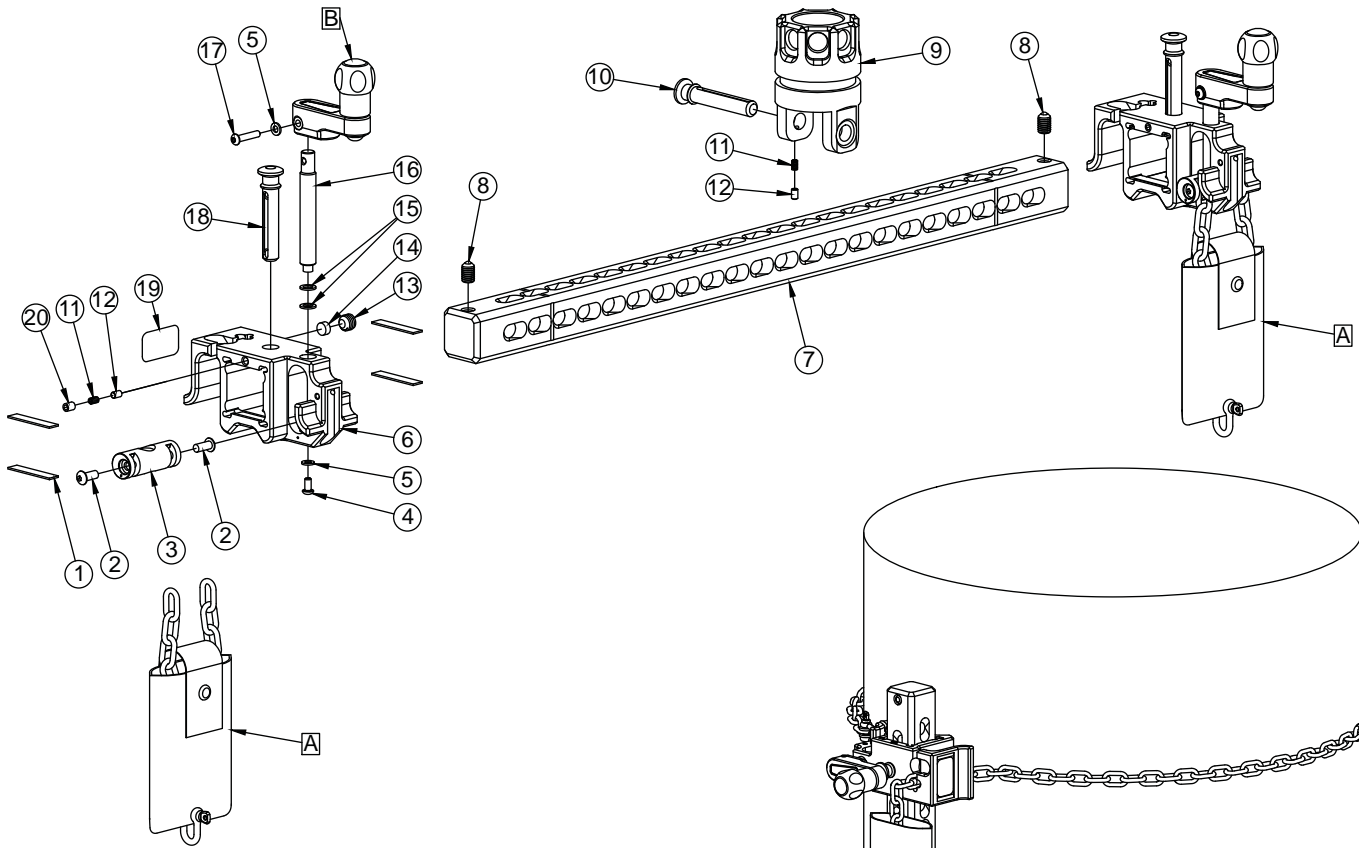

#	DESCRIPTION	QTY.	PART #
1	WEAR STRIP	8	HE134
2	5/16-18 X 3/4 BUTTON HEAD	4	VT31E18BH750
3	CHAIN TENSIONER	2	HE146
4	1/4-20 X 1/2 BUTTON HEAD SCREW	2	VT25-20BH500
5	WASHER	4	VW500X265-63
6	CHAIN CLAMP BRACKET	2	HE145
7	MOUNTING CLAMP BACKBONE	1	HE160
8	PLUNGER	2	XXL505
9	CLAMP MOUNTING BASE	1	HE102A
10	CAPTURED MOUNTING PIN	1	HE178
11	DETENT SPRING	3	HM770
12	LATCH PIN	3	HE175
13	5/8-11 X 1/2 SOCKET SET SCREW	2	VT62-11SS500
14	MAGNET	2	HE148
15	WASHER	4	VW390X630-070
16	5/8" THREADED ROD	2	HE147
17	1/4-20 X 1.25 BUTTON HEAD SCREW	2	VT25-20BH1.2
18	CAPTURED BLOCK PIN	2	HE188
19	TASK FORCE TIPS LOGO LABEL	2	HE195
20	5/16-18 X 3/8 SOCKET SET SCREW	2	VT31-18SS375
A	3/16" CHAIN SUBASSEMBLY	2	HE810
B	CRANK WITH KNOB SUBASSEMBLY	2	HE803

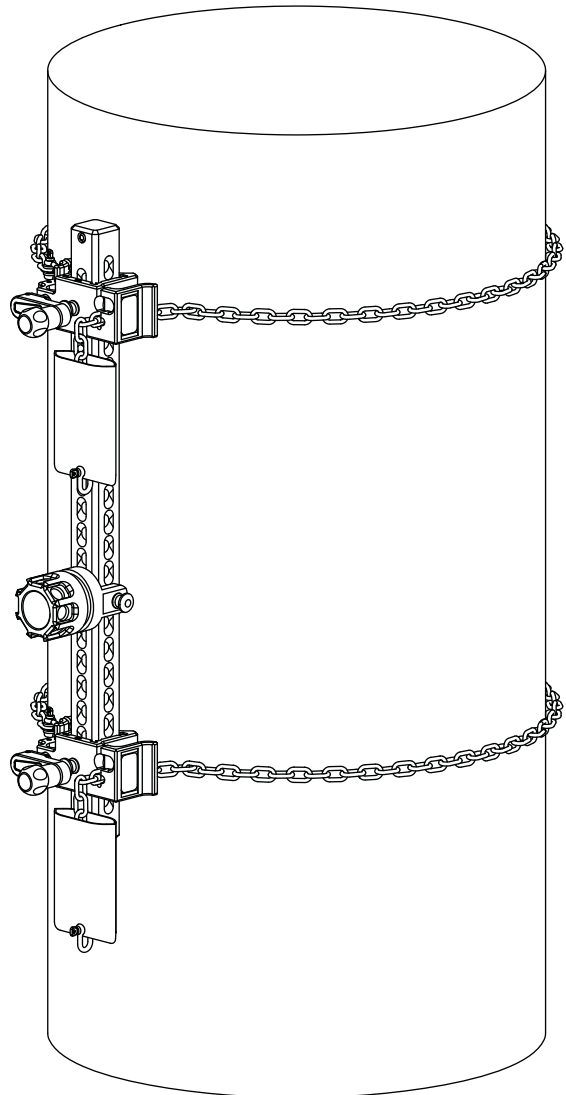

5.0 WARRANTY

Task Force Tips LLC, 3701 Innovation Way, Valparaiso, Indiana 46383-9327 USA ("TFT") warrants to the original purchaser of its Hemisphere Monitor ("equipment"), and to anyone to whom it is transferred, that the equipment shall be free from defects in material and workmanship during the five (5) year period from the date of purchase.

TFT's obligation under this warranty is specifically limited to replacing or repairing the equipment (or its parts) which are shown by TFT's examination to be in a defective condition attributable to TFT. To qualify for this limited warranty, the claimant must return the equipment to TFT, at 3701 Innovation Way, Valparaiso, Indiana 46383-9327 USA, within a reasonable time after discovery of the defect. TFT will examine the equipment. If TFT determines that there is a defect attributable to it, it will correct the problem within a reasonable time. If the equipment is covered by this limited warranty, TFT will assume the expenses of repair.

If any defect attributable to TFT under this limited warranty cannot be reasonably cured by repair or replacement, TFT may elect to refund the purchase price of the equipment, less reasonable depreciation, in complete discharge of its obligations under this limited warranty. If TFT makes this election, claimant shall return the equipment to TFT free and clear of any liens and encumbrances.

This is a limited warranty. The original purchaser of the equipment, any person to whom it is transferred, and any person who is an intended or unintended beneficiary of the equipment, shall not be entitled to recover from TFT any consequential or incidental damages for injury to person and/or property resulting from any defective equipment manufactured or assembled by TFT. It is agreed and understood that the price stated for the equipment is in part consideration for limiting TFT's liability. Some states do not allow the exclusion or limitation of incidental or consequential damages, so the above may not apply to you.

TFT shall have no obligation under this limited warranty if the equipment is, or has been, misused or neglected (including failure to provide reasonable maintenance) or if there have been accidents to the equipment or if it has been repaired or altered by someone else.

THIS IS A LIMITED EXPRESS WARRANTY ONLY. TFT EXPRESSLY DISCLAIMS WITH RESPECT TO THE EQUIPMENT ALL IMPLIED WARRANTIES OF MERCHANTABILITY AND ALL IMPLIED WARRANTIES OF FITNESS FOR A PARTICULAR PURPOSE. THERE IS NO WARRANTY OF ANY NATURE MADE BY TFT BEYOND THAT STATED IN THE DOCUMENT.

This limited warranty gives you specific legal rights, and you may also have other rights which vary from state to state.

Visit TFT's web site at tft.com

6.0 MAINTENANCE

The Hemisphere Transportable Monitor requires little maintenance. The unit should be kept clean and free of dirt by rinsing with water after each use. Any inoperable or damaged parts should be repaired or replaced before placing the unit in service.

In applications where appliances are left continuously connected to the apparatus or other devices or are used where water is trapped inside the appliance, the appliance must be flushed with fresh water following each use and inspected for damage.

This Hemisphere should be disconnected, cleaned and visually inspected inside and out at least quarterly, or as water quality and use may require. Moving parts such as handles, valve ball and couplings should be checked for smooth and free operation. Seals shall be greased as needed with Silicone based grease such as Dow Corning 112. Any scrapes that expose bare aluminum should be cleaned and touched up with enamel paint such as Rust-Oleum. Replace any missing or damaged parts before returning to service.



Any alterations to the Hemisphere and its markings could diminish safety and constitutes a misuse of this product.

Any Hemisphere taken out of service due to failure should be returned to the factory for repair or replacement. If you have any questions regarding the testing or maintenance of your valve, please call Task Force Tips at 800-348-2686.

6.1 SERVICE TESTING

In accordance with NFPA 1962 (2013), appliances must be tested a minimum of annually. Appliances failing any part of this test must be removed from service, repaired and retested upon completion of the repair.

6.1.1 HYDRAULIC TEST

1. The appliance being tested shall be positioned in a protective device or cover capable of holding the appliance and tested to a minimum hydrostatic pressure of 300 psi (20.7 bar or 2070 kPa).
2. Test caps capable of withstanding the required hydrostatic pressure shall be attached to openings, and a device capable of exerting the required hydrostatic pressure shall be attached to the appliance.
3. Appliances with relief valves shall have the relief valve outlet blanked off or otherwise closed during the test.
4. All air shall be bled from the system.
5. The gage pressure shall be increased by 50 psi (3.45 bar or 345 kPa) increments and held for 30 seconds at each pressure up to the maximum pressure for which the appliance is being tested and held for 1 minute without leakage.

6.1.2 SHUTOFF VALVE TEST

1. If the appliance has a shutoff valve, the intake side of the shutoff valve shall be hydrostatically pressurized to the maximum working pressure of the appliance with the valve in the shutoff position.
2. There shall be no leakage through the valve.
3. A water flow through the fire hose appliance at 100 psi (6.9 bar or 690 kPa) shall be established.
4. The valve shall be closed and reopened twice and shall operate smoothly without evidence of binding or other problems.

6.1.3 RECORDS

A record of testing and repairs must be maintained from the time the appliance is purchased until it is discarded. Each TFT appliance is engraved with a unique serial number which, if so desired, can be used to identify the appliance for documentation purposes.

The following information, if applicable, must be included on the test record for each appliance:

1. Assigned identification number
2. Manufacturer
3. Product or model designation
4. Vendor
5. Warranty
6. Hose connection size
7. Maximum operating pressure
8. Flow rate or range
9. Date received and date put in service
10. Date of each service test and service test results
11. Damage and repairs, including who made the repairs and the cost of repair parts
12. Reason removed from service

NFPA 1962: Standard for the care, use, inspection, service testing, and replacement of fire hose, couplings, nozzles and fire hose appliances. (2013 ed., Section 6.4.4). Quincy, MA: National Fire Protection Agency.

6.2 REPAIR

Factory service is available with repair time seldom exceeding one day in our facility. Factory serviced appliances are repaired by experienced technicians to original specifications, fully tested and promptly returned.

Repair parts and service procedures are available for those wishing to perform their own repairs. Task Force Tips assumes no liability for damage to equipment or injury to personnel that is a result of user service.

For additional information on care, maintenance and testing, refer to: NFPA 1962: Standard for the Care, Use, Inspection, Service Testing, and Replacement of Fire Hose, Couplings, Nozzles, and Fire Hose Appliances, 2013 Edition

6.3 DOUBLE BALL PIVOT SYNCHRONIZER AND LOCK MAINTENANCE

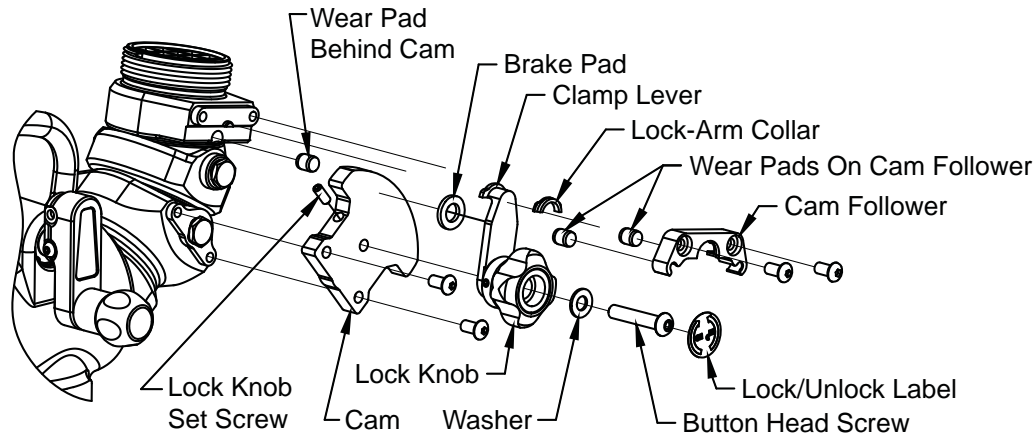

It is important to clean, inspect, and maintain the synchronizing mechanism regularly, and before each use, as needed. The assembly can be brushed clean with soap and water. The mechanism consists of a cam, cam follower, wear pads, and a lock mechanism.

The wear pads are press fit in place, and will need to be maintained periodically. Indications that maintenance is needed include: difficulty rotating the double ball swivel assembly, inability to lock the double balls, and metal to metal contact between the cam follower and the cam. Removing the two pads on the cam follower:

1. Remove the two (2) 5/16" button head screws (with a 3/16" hex wrench) that hold the cam follower in place and remove the cam follower.
2. Secure the cam follower in a soft jaw (or equivalent) vise, and tap with a punch and hammer on the backside of the pads until they are removed.
3. Remove the pad located behind the cam in the pocket on the side of the pivot ball.
4. Remove the cam follower and the cam.
5. Drill the center of the worn pad with a 1/8" drill, to form a pilot hole. Then drill with a 3/8" drill bit. Both drills must be fitted with a travel stop, to prevent the drill from going more than 7/16" into the pad.
6. The remaining pad material can be pried out with a screwdriver or a small pry bar. Replace the pad by tapping a new pad into the bore with a punch and hammer.

The brake pad and lock arm collar should be inspected periodically to ensure that the lock provides sufficient engagement to prevent unwanted nozzle sweep. The brake pad and lock arm collar can be accessed by removing the cam follower and lock arm. Once the cam follower is removed, the lock arm collar can be removed, and the lock arm can be removed by removing the set screw in the side of the cam and unscrewing the lock knob screw that attaches the knob to the cam. The brake pad can be removed by prying it off of the boss it is press fit onto.

Apply Loctite #242 (blue) to all screws before reassembly, except the lock knob screw. Loctite should be applied to the female threads that mate with the lock knob screw on the cam. Do not apply Loctite to the female threads that mate with the lock knob screw on the lock knob. The lock knob screw should be greased with Chuck-eez (or equivalent molybdenum disulfide based grease) on the upper half of the threads only. Any grease on the lower 1/2" of threads should be cleaned with acetone before assembling the screw onto the cam. Once all parts of the lock mechanism, except for the lock/unlock label, are assembled, and before the Loctite sets, rotate the lock knob counterclockwise about the lock knob screw until the head of the screw is snug against the washer and the washer is snug against the lock knob. Rotate the knob/screw clockwise until the knob snugs up against the clamp lever, turn it back 1/4 turn counterclockwise, and tighten the set screw. Verify that the double ball assembly moves freely with the lock knob in the unlock position, and that the ball swivels cannot be moved with the lock/unlock knob in the lock position. Clean any grease off the label groove with acetone and apply a new lock/unlock label.

6.4 LOCK PIN ASSEMBLY

Free movement of the rotational lock pin can be verified by pulling back on the rotation lock pin release lever, and can be verified for the axial lock pin by pressing in on the indicator. The lock pin assembly should be disassembled, inspected, and cleaned if the pins are not functioning properly. Disassembly can be accomplished by using snap ring pliers to remove the snap ring retaining the indicator plug, and two 9/16" open end wrenches to remove one of the rotation lock release levers from the rotation release lever shaft. Damaged or worn pins or o-rings should be replaced. Apply a silicone-based grease such as Dow Corning 112 to all seals prior to installation. Apply a light coat of Chuck-eez (or equivalent molybdenum disulfide based grease) to the pin bores in the monitor body and the rotational lock pin prior to installing the pins. Apply Loctite #246 (red) compound to the pin retract shaft threads before reinstalling the rotation lock release lever.

7.0 ANSWERS TO YOUR QUESTIONS

We appreciate the opportunity of serving you and making your job easier. If you have any problems or questions, our toll-free "Hydraulics Hotline", 800-348-2686, is normally available to you 24 hours a day, 7 days a week.

8.0 OPERATION and INSPECTION CHECKLIST

BEFORE EACH USE, appliances must be inspected to this checklist:

- There is no obvious damage such as missing, broken or loose parts, dents, cracks, corrosion, or other defects that could impair operation
- Clamp and mounted object are secure
- Monitor is securely attached to the mount
- Hose and nozzle are securely attached
- All swiveling elements rotate freely
- The monitor release and rotation lock pins engage and disengage fully.
- Waterway rotation crank moves freely and waterway rotates full 360 degrees
- Monitor is pointed in a safe direction
- Valve handle lock engages and releases
- Quarter turn valve opens and closes fully and smoothly
- The pressurized pin position indicator moves in flush with the plug when the monitor is pressurized

BEFORE BEING PLACED BACK IN SERVICE, appliances must be inspected to this list:

- Valves opens and closes smoothly and fully.
- The waterway is clear of obstructions.
- There is no damage to any thread or other type connection.
- All locks and hold-down devices work properly.
- Internal gaskets are in accordance with NFPA 1962 (2013) Section 7.2.
- There is no damage to the appliance that could impair safe operation (e.g. dents, cracks, corrosion or other defects)
- All swiveling connections rotate freely.
- There are no missing parts or components.
- The marking for maximum operating pressure is visible.
- There are no missing, broken, or worn lugs on couplings.

NFPA 1962: Standard for the care, use, inspection, service testing, and replacement of fire hose, couplings, nozzles and fire hose appliances. (2013 ed., Section 6.2.1). Quincy, MA: National Fire Protection Agency.

WARNING

Any appliance failing any part of the inspection checklist is unsafe and must have the problem corrected before use. Operating a appliance that fails any of the above inspections is a misuse of this equipment.