



# MANUAL: BLITZFIRE® Portable Monitor Series

## INSTRUCTIONS FOR SAFE OPERATION AND MAINTENANCE

### **⚠ DANGER**

Understand manual before use. Operation of this device without understanding the manual and receiving proper training is a misuse of this equipment. Obtain safety information at [www.tft.com/serial-number](http://www.tft.com/serial-number)

### **⚠ DANGER**

Risk of sliding increases at low elevation angles. To reduce risk of injury or death from sliding, test safety shutoff valve before using.

This Instruction Manual is intended to familiarize firefighters and maintenance personnel with the operation, servicing, and safety procedures associated with the portable monitor.

This manual should be kept available to all operating and maintenance personnel.

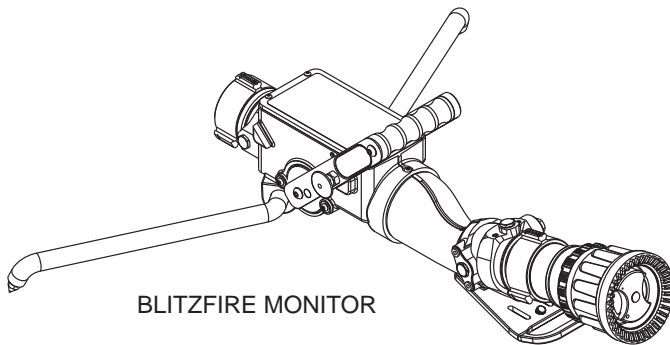

BLITZFIRE MONITOR

**BLITZFIRE®**

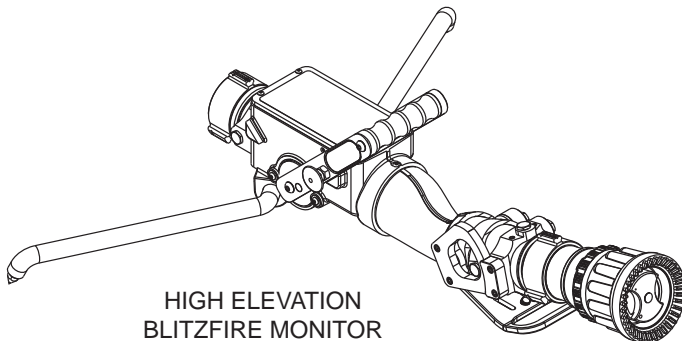

HIGH ELEVATION  
BLITZFIRE MONITOR

**MAXIMUM OPERATING PRESSURE**  
175 PSI (12 BAR)

**MAXIMUM FLOW**  
500 GPM (2000 LPM)

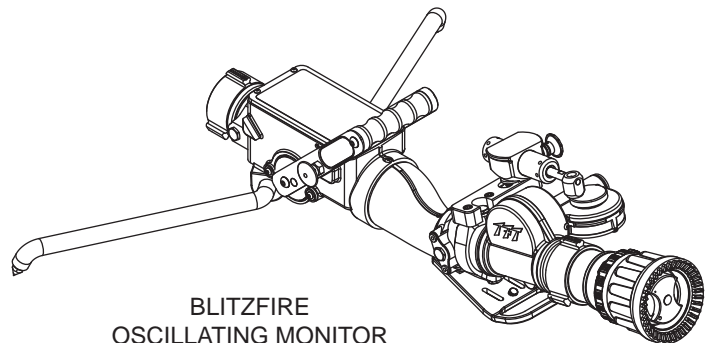

BLITZFIRE  
OSCILLATING MONITOR

**BLITZFIRE® OSC**

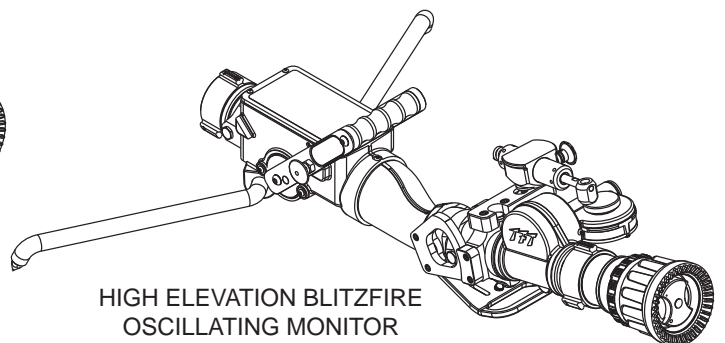

HIGH ELEVATION BLITZFIRE  
OSCILLATING MONITOR

**TASK FORCE TIPS, INC.**  
MADE IN USA • [www.tft.com](http://www.tft.com)

3701 Innovation Way, Valparaiso, IN 46383-9327 USA  
800-348-2686 • 219-462-6161 • Fax 219-464-7155



#### PERSONAL RESPONSIBILITY CODE

The member companies of FEMSA that provide emergency response equipment and services want responders to know and understand the following:

1. Firefighting and Emergency Response are inherently dangerous activities requiring proper training in their hazards and the use of extreme caution at all times.
2. It is your responsibility to read and understand any user's instructions, including purpose and limitations, provided with any piece of equipment you may be called upon to use.
3. It is your responsibility to know that you have been properly trained in Firefighting and /or Emergency Response and in the use, precautions, and care of any equipment you may be called upon to use.
4. It is your responsibility to be in proper physical condition and to maintain the personal skill level required to operate any equipment you may be called upon to use.
5. It is your responsibility to know that your equipment is in operable condition and has been maintained in accordance with the manufacturer's instructions.
6. Failure to follow these guidelines may result in death, burns or other severe injury.



Fire and Emergency Manufacturers and Service Association  
P.O. Box 147, Lynnfield, MA 01940 • [www.FEMSA.org](http://www.FEMSA.org)

# Table Of Contents

- 1.0 Meaning of Safety Signal Words
- 2.0 General Information
  - 2.1 Blitzfire Part Identification
  - 2.2 Flow Control Valve
    - 2.2.1 Unlocking the Valve Handle from the Closed Position
    - 2.2.2 Safety Shut-Off Valve Operation
    - 2.2.3 Safety Shut-Off Valve Test
    - 2.2.4 Manual Override of Safety Shut-Off Valve
    - 2.2.5 Slow Close Valve Feature
  - 2.3 Folding Legs
    - 2.3.1 Carbide Spikes
  - 2.4 Pivoting Inlet
  - 2.5 Outlet Pivots
    - 2.5.1 Elevation Holding Mechanism
- 3.0 Flows and Pressures
  - 3.1 Automatic, Fixed, and Selectable Flow Nozzles
  - 3.2 Stacked Tips or Smoothbore Nozzles
  - 3.3 Stream Straighteners
  - 3.4 Use with Foam
  - 3.5 Use with Salt Water
  - 3.6 Blitzfire Pressure Loss
- 4.0 Deployment of Blitzfire
  - 4.1 Carrying with an Uncharged Hose
  - 4.2 Advancing with a Charged Hose
- 5.0 Anchoring
  - 5.1 Anchoring by Weight
  - 5.2 Anchoring by Spike Holds
  - 5.3 Anchoring by Hooking Legs
  - 5.4 Anchoring by Tying Off
- 6.0 OSC Oscillating Unit
  - 6.1 Safety - Oscillator
  - 6.2 General - Oscillator
  - 6.3 Oscillator
  - 6.4 Oscillating Speed and Coverage
- 7.0 Storage
- 8.0 Maintenance
- 9.0 Warranty
- 10.0 Exploded View and Parts List
  - 10.1 Safety Mechanism Assembly View
  - 10.2 Blitzfire Monitor Exploded View
  - 10.3 Standard Blitzfire Outlet Exploded View
  - 10.4 High Elevation Blitzfire Outlet Exploded View
  - 10.5 Blitzfire Oscillator Exploded View
- 11.0 Operation Checklist

## 1.0 MEANING OF SAFETY SIGNAL WORDS

A safety related message is identified by a safety alert symbol and a signal word to indicate the level of risk involved with a particular hazard. Per ANSI standard Z535.6-2011, the definitions of the four signal words are as follows:

**⚠ DANGER**

**DANGER** indicates a hazardous situation which, if not avoided, will result in death or serious injury.

**⚠ WARNING**

**WARNING** indicates a hazardous situation which, if not avoided, could result in death or serious injury.

**⚠ CAUTION**

**CAUTION** indicates a potentially hazardous situation which, if not avoided, may result in minor or moderate injury.

**NOTICE**

**NOTICE** is used to address practices not related to physical injury.

## 2.0 GENERAL INFORMATION

The Blitzfire is a simple, light and easy to maneuver portable monitor. The monitor has a revolutionary safety shut-off valve, which will shut-off the water flow in the event of sudden movement by the monitor. This safety feature reduces the risk of injury from an out of control master stream device. General product specifications are as follows:

- Standard Inlet Coupling: 2 ½ inch NH Female
- Standard Outlet: 2 ½ inch NH male
- Flow range: up to 500 GPM (2000 LPM)
- Maximum inlet pressure: 175 PSI (12 BAR)
- Vertical Stream Range: 10 to 46 or 86 degrees above horizontal
- Horizontal Stream Range: +/- 20 degrees either side of centerline
- Size, legs folded: 25.5"L x 8.1"W x 10"H (650x210x260mm)
- Size, legs unfolded: 26"L x 35"W x 10"H (660x920x260mm)
- Weight: 22 lbs (10 kg)

**⚠ WARNING**

This equipment is intended for use by trained personnel for firefighting. Its use for other purposes may involve hazards not addressed by this manual. Seek appropriate guidance and training to reduce risk of injury.

**⚠ WARNING**

An out of control monitor can cause injury or death. To reduce the risk of instability, do not attempt to move the monitor with water flowing.

**⚠ WARNING**

Interrupting flow to the monitor may cause injury or death. Avoid situations that may interrupt flow to the monitor such as: hose line kinks, traffic running over hose, and automatic doors or devices that can pinch the hose.

**⚠ WARNING**

The monitor may be damaged if frozen while containing sufficient amounts of water. Such damage may be difficult to detect visually and can lead to possible injury or death. Any time the monitor is subject to possible damage from freezing, it must be hydrostatically tested by qualified personnel before being considered safe for use.

**⚠ WARNING**

Use of compressed air foam (CAF) with portable nozzles can cause sudden surges in nozzle reaction force resulting in injury or death from loss of footing, hose whipping, or an out of control portable monitor. Be prepared for sudden changes in nozzle reaction caused by: Slug loading (Loss of foam concentrate sends slugs of air and water into the nozzle) Sudden release of built-up pressure in the hose when opening a nozzle.

**⚠ CAUTION**

Master streams are powerful and capable of causing injury and property damage. Make sure the monitor is pointing in a safe direction before water to the nozzle is turned on. Use care in directing the stream.

**⚠ CAUTION**

Monitor must be properly connected to hose and nozzle. Mismatched or damaged threads may cause leaking or uncoupling under pressure and could cause injury.

**⚠ CAUTION**

Do not couple aluminum to brass. Dissimilar metal coupled together can cause galvanic corrosion that can result in inability to unscrew threads or complete loss of thread engagement over time.

**⚠ CAUTION**

Use with salt water is permissible provided the monitor is thoroughly cleaned with fresh water after each use. The service life of the monitor may be shortened due to the effects of corrosion and is not covered under warranty.

## 2.1 BLITZFIRE PART IDENTIFICATION

The Blitzfire is available in standard and high elevation models. Figure 2.1 identifies the various parts and controls on a standard Blitzfire portable monitor. Parts and controls for a high elevation model are similar.

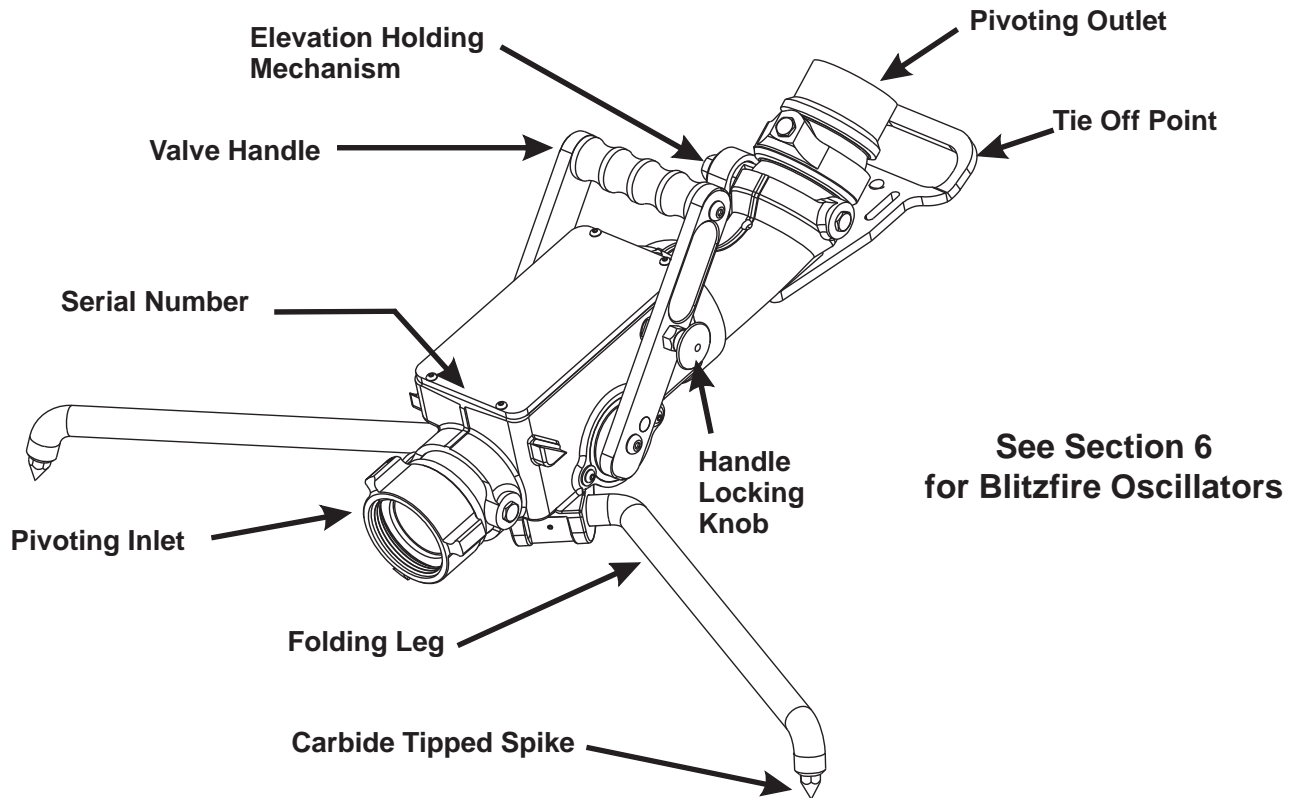

Figure 2.1 Blitzfire Parts and Controls

## 2.2 FLOW CONTROL VALVE

The Blitzfire has a valve that can be used to control the flow and acts as a safety shut-off feature. The valve is shut-off when the valve handle is fully forward. The valve is fully on when the valve handle is fully back. The valve can be opened to any of six detented flow positions. These detented positions allow the monitor operator to regulate the flow depending on the need or what can be safely and effectively handled. Figure 2.2 illustrates the positions of the valve handle.

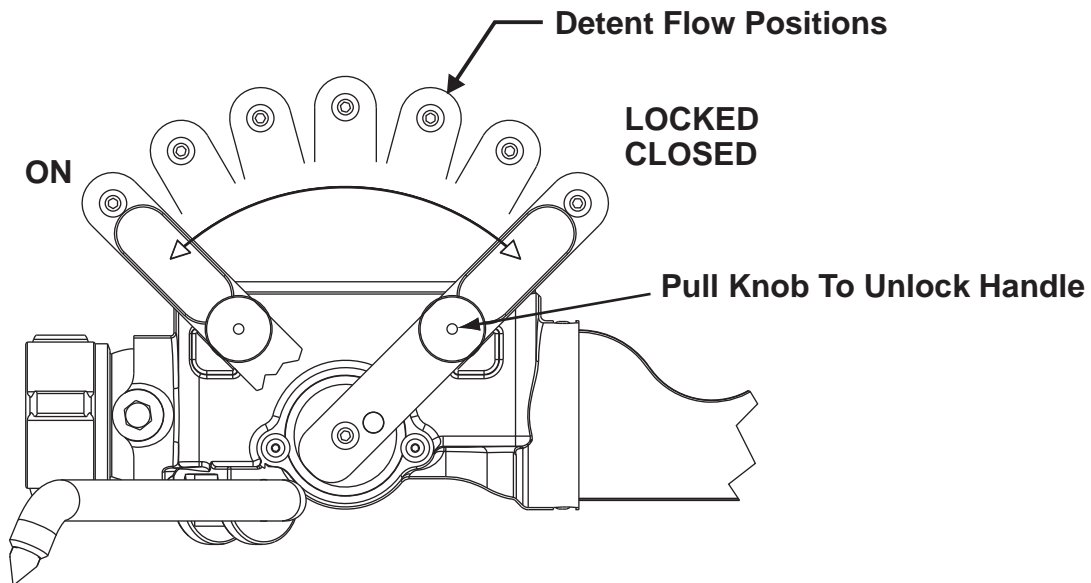

Figure 2.2 Valve Handle Positions

## 2.2.1 UNLOCKING THE VALVE HANDLE FROM THE CLOSED POSITION

The valve handle is locked in the closed position so that the valve handle may be used to carry the Blitzfire without the valve inadvertently opening. To unlock the valve handle from the closed position:

1. Pull knob on right side of the valve handle.
2. While pulling on knob, open the valve with the other hand.

As soon as valve is opened the knob may be released. The valve handle may be moved to any detent valve position by pushing or pulling on the valve handle. When the valve is closed the valve handle automatically locks and must be unlocked again to reopen. The valve opening procedure is shown in figure 2.2.1.

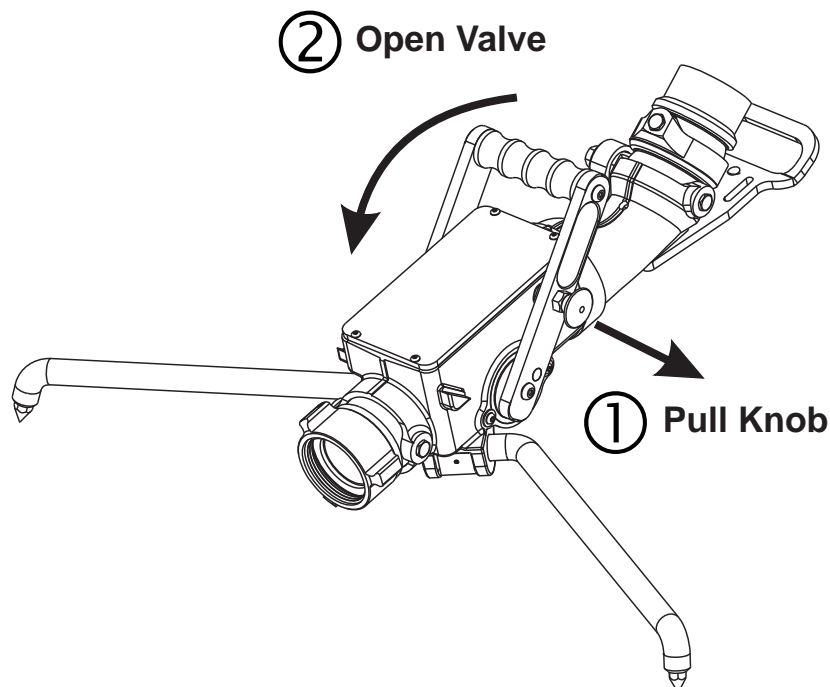
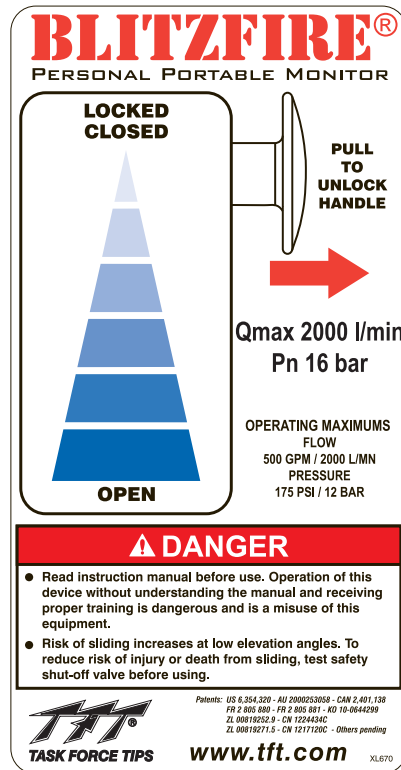

Figure 2.2.1 Valve Opening Procedure

## 2.2.2 SAFETY SHUT-OFF VALVE OPERATION

The Blitzfire is equipped with a Safety Shut-Off Valve. The Safety Shut-Off Valve will shut off the monitor's flow if the monitor starts to move. The Safety Shut-Off Valve relies on acceleration of the Blitzfire as the signal to activate. It activates at approximately one G of sideways acceleration. Placing the Blitzfire on tilted surfaces (greater than 10 degrees) may inhibit the resetting of the Safety Shut-Off Valve. The hose connected to the Blitzfire should contain any forward or backwards motion to safe levels.

**NOTE: To make the Blitzfire not shut off completely, see the card titled "Instructions to Maintain Minimal Water Flow When the Safety Shut-off Activates". (LIX-640)**

Safety shut-off valve operation:

1. Set up monitor and charge the hose.
2. Point the nozzle in the desired direction.
3. Open the valve by pulling the locking pin and pulling back on the valve handle (see section 2.2.1)
4. Place the valve handle in the desired detent position (further back for more flow, further forward for less).
5. If the monitor starts to slide, the safety valve will sense the movement and release the valve.
  - An internal spring and water pressure will move the valve forward to the closed position and shut off the water flow.
  - The valve handle will lock in the closed position.
6. The safety shut-off valve will automatically reset.
7. After the cause of the sliding has been corrected, reopen the valve as outlined in step 3.

**IMPORTANT: Valve must be fully closed to reset the safety shut-off mechanism. Once tripped the valve handle will not stay open unless the mechanism is reset by fully closing the valve.**

If the safety shut-off valve fails to reset, the valve will not remain open. Failure to reset may be due to placing the monitor on an excessively sloped surface.

### **⚠ WARNING**

The safety shut-off valve is only sensitive to sideways acceleration of the monitor. Keep the hose directly behind the monitor to reduce potential acceleration in the forward and backward direction. Do not loop hose in front of monitor.

### **⚠ WARNING**

The safety shut-off valve needs approximately one G of sideways acceleration to activate. At low accelerations the monitor may travel several yards (meters) and gain enough velocity to cause injury before the safety shut-off valve activates. Personnel several feet away and in the potential path of a sliding monitor are at risk of injury. Keep non operating personnel out of the potential path of a sliding monitor.

### **⚠ WARNING**

Improper repairs may result in a malfunctioning safety shut-off valve. If repair is needed on the safety shut-off valve, return the monitor to Task Force Tips.

## 2.2.3 SAFETY SHUT-OFF VALVE TEST

### **⚠ WARNING**

To avoid injury or death, test safety shut-off valve before each use.

With hose uncharged and Blitzfire on a level surface:

1. Open the Valve Handle to the fully open position.
2. Grasp the monitor and give it a sideways jerk, rotate to trip the valve or hit on the side with a rubber mallet.
3. The Valve Handle should move to the closed position.

Note: With water flowing the valve has additional forces on it that will close the valve the rest of the way.

If the Safety Shut-Off Valve fails the test, return the monitor to Task Force Tips to restore proper functioning of the safety shut-off valve. If the monitor is used before repair, the user accepts the risk of an out of control monitor.

### **⚠ WARNING**

The safety shut-off valve is intended to shut off the monitor when it moves. It will not prevent it from moving. The device shall limit the motion and injury that may occur once the monitor starts to move. Use adequate means to secure the monitor to prevent injury.

### **⚠ WARNING**

Injury or death from an out of control monitor can occur. If monitor gets out of control retreat from monitor immediately. Do not attempt to regain control of monitor while it is flowing.



## 2.2.4 MANUAL OVERRIDE OF SAFETY SHUT-OFF VALVE

On sloping terrain it may be necessary to manually override the Safety Shut-Off Valve. The Safety Shut-Off Valve can be overridden by holding the valve handle in an open position.

### **⚠️ WARNING**

**Do not tie or prop open the valve handle. Tampering with the valve handle will render the Safety Shut-Off inoperable and may result in injury or death.**

## 2.2.5 SLOW CLOSE VALVE FEATURE

The Blitzfire has a valve damping mechanism to slow valve closure as it approaches OFF to reduce the effects of water hammer. The damping mechanism has a vane moving in dampening fluid connected to the valve handle on the left side of the monitor.

### **⚠️ WARNING**

**Do not add or change dampening fluid. Improper servicing may result in a malfunctioning safety shut-off valve. If service is needed on the slow close device, contact Task Force Tips service department at 800-348-2686.**

### **⚠️ WARNING**

**“Water Hammer” is present any time a valve is closed when water is flowing. The effects of water hammer can be made worse with short hose lines, small hose lines, and high flows. All personnel operating in the vicinity of charged hose lines should be especially cautious around any hose that is providing high flows that might be shut off quickly in an emergency. The dampening device in the Blitzfire monitor reduces the effects of water hammer but DOES NOT ELIMINATE IT!**

## 2.3 FOLDING LEGS

The Blitzfire has two legs that fold for storage and unfold for operation. The legs are held in the folded and unfolded position by spring detents. To fold or unfold the legs:

1. Grasp the spike end of one leg and pivot it to the folded or unfolded position.
2. Repeat for the other leg.

### 2.3.1 CARBIDE SPIKES

The Blitzfire monitor has 3 tungsten carbide tipped spikes on the legs and the base to resist sliding by digging into the surface the monitor is sitting on. The amount of sliding force these spikes can withstand depends upon the amount of downward and sideways force that is on the monitor and the hardness and texture of the surface the spikes are in contact with. At low elevation angles it is difficult for these spikes to resist sliding. These spikes are essential to safe operation of the monitor and must be in contact with the ground at all times. Set the monitor on an even surface so that all three spikes contact the ground. Replace any spike if the tip diameter exceeds 1/16 inch (1.6 mm). Order replacement spike kit: XX482-KIT.

### **⚠️ WARNING**

**For stable operation the three spikes must maintain in contact with the ground. Do not place the Blitzfire on top of debris, objects, or uneven terrain that would keep any of the spikes from contacting the ground.**

### **⚠️ WARNING**

**On hard slippery surfaces the spikes may provide little resistance to sliding. In these cases the monitor should be tied off or the legs hooked on stationary objects to keep the monitor in position. Also, a person’s weight applied to the monitor may help increase resistance to sliding.**

### **⚠️ CAUTION**

**Spikes must be sharp to provide resistance to sliding. Replace any spike if the tip diameter exceeds 1/16 inch (1.6 mm).**

### **⚠️ CAUTION**

**Spikes are sharp and exposed. Use care around spikes to avoid injury and damage to clothing or other property.**

## 2.4 PIVOTING INLET

The Blitzfire has a pivoting inlet so that different size hoses can be used without lifting the spikes off the ground. The pivoting inlet also allows the monitor to be positioned on porches, stair landings, and the like. The pivot moves up and down 20 degrees. The Blitzfire is equipped with three spikes to provide traction when flowing from the ground. For the spikes to provide traction they must remain in contact with the ground. Assure that the hose is not on top of anything that would cause the spikes to lift off the ground. Figure 2.5a and 2.5b shows the inlet pivot.

## 2.5 OUTLET PIVOTS

Figure 2.5a and 2.5b shows the outlet pivot travel range. Push or pull on the nozzle to redirect the stream. The pivots are easy to reposition under pressure and are good for rapid redirecting of the stream. However, if the pivot is rapidly bumped against its travel limit, the Safety Shut-Off Valve may activate and shut off the monitor. Figures 2.5a and 2.5b shows the outlet pivots range of motion. The Blitzfire has been designed to operate at very low elevation angles to maximize usefulness for interior attack. As with any monitor, when the elevation angle is low the risk of sliding is increased. This is because at low elevation angles the reaction force is more horizontal and less vertical.



**Elevation drag adjusting nut.**  
Tighten to increase drag. Loosen to decrease drag. Do not exceed 200 in-lb (22N-M) of holding torque.

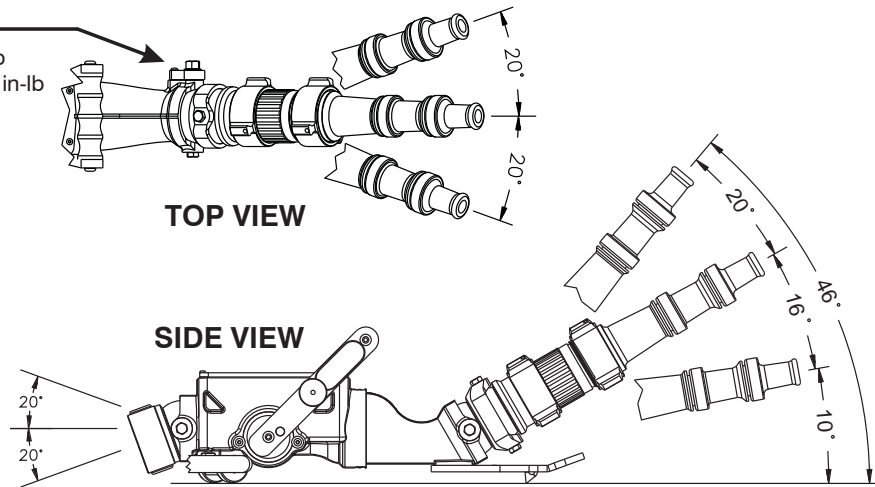

Figure 2.5a Blitzfire Travel Range

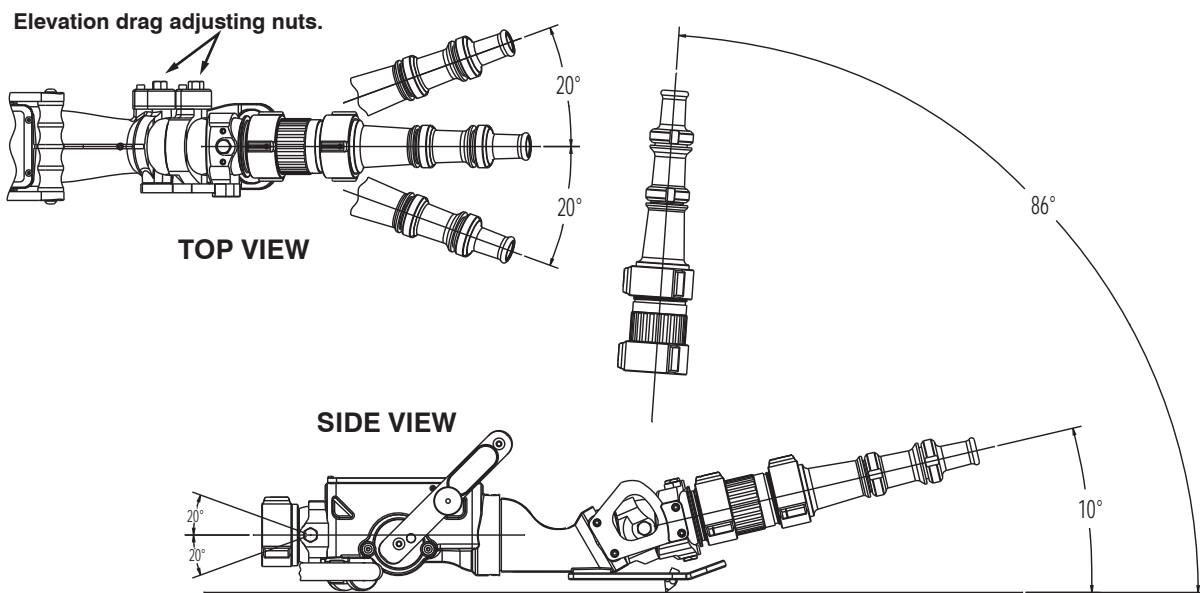

Figure 2.5b Blitzfire High Elevation Travel Range

### 2.5.1 ELEVATION HOLDING MECHANISM

The elevation pivot has a mechanism to support the weight of a nozzle. It is factory set to support the weight of nozzles likely to be used. It may be adjusted (see figure 2.5a and 2.5b). The mechanism releases when raising the nozzle so upwards drag from the mechanism is not felt. Avoid the use of long stream straighteners or heavy nozzles which may overcome the holding torque of the elevation mechanism.

#### **NOTICE**

Only tighten in small increments and only tighten just enough to compensate for the weight of the nozzle (and FoamJet, if applicable). Over tightening of the drag nut will cause damage or premature wear to the elevation holding mechanism.

### 3.0 FLOWS AND PRESSURES

The Blitzfire Portable Monitor is designed for maximum flows of 500 GPM (2000 LPM) and a maximum nozzle exit pressure of 175 PSI (12 BAR). Do not exceed these limits.

#### **WARNING**

An inadequate supply of pressure and/or flow will cause an ineffective stream and can result in injury, death or loss of property.

### 3.1 AUTOMATIC, FIXED, AND SELECTABLE FLOW NOZZLES

A variety of water or foam nozzles may be used with the Blitzfire.

Automatic nozzles maintain a constant pressure by adjusting their opening to match the available flow. Consult the nozzle manufacturer for maximum flow and pressure ratings. In all cases do not exceed 500 GPM (2000 LPM) and/or 175 PSI (12 BAR) nozzle exit pressure.

### 3.2 STACKED TIPS OR SMOOTHBORE NOZZLES

| NOZZLE DIAMETER | NOZZLE EXIT PRESSURE |                |            |                |            |                |            |                |            |                |
|-----------------|----------------------|----------------|------------|----------------|------------|----------------|------------|----------------|------------|----------------|
|                 | 50 PSI               |                | 80 PSI     |                | 100 PSI    |                | 150 PSI    |                | 175 PSI    |                |
|                 | FLOW (GPM)           | REACTION (LBS) | FLOW (GPM) | REACTION (LBS) | FLOW (GPM) | REACTION (LBS) | FLOW (GPM) | REACTION (LBS) | FLOW (GPM) | REACTION (LBS) |
| 1.0 INCH        | 210                  | 80             | 266        | 126            | 297        | 157            | 364        | 236            | 390        | 275            |
| 1-1/4 INCH      | 328                  | 120            | 415        | 196            | 464        | 245            | —          | —              | —          | —              |
| 1-1/2 INCH      | 473                  | 177            | —          | —              | —          | —              | —          | —              | —          | —              |

| NOZZLE DIAMETER | NOZZLE EXIT PRESSURE |               |              |               |              |               |              |               |              |               |
|-----------------|----------------------|---------------|--------------|---------------|--------------|---------------|--------------|---------------|--------------|---------------|
|                 | 4 BAR                |               | 6 BAR        |               | 8 BAR        |               | 10 BAR       |               | 12 BAR       |               |
|                 | FLOW (L/min)         | REACTION (KG) | FLOW (L/min) | REACTION (KG) | FLOW (L/min) | REACTION (KG) | FLOW (L/min) | REACTION (KG) | FLOW (L/min) | REACTION (KG) |
| 25 MM           | 830                  | 40            | 1000         | 60            | 1200         | 80            | 1300         | 100           | 1400         | 120           |
| 32 MM           | 1300                 | 70            | 1700         | 100           | 1900         | 130           | —            | —             | —            | —             |
| 38 MM           | 1900                 | 90            | —            | —             | —            | —             | —            | —             | —            | —             |



**FLOW EXCEEDS RATING OF BLITZFIRE PORTABLE MONITOR**

### 3.3 STREAM STRAIGHTENERS

Stream quality, especially with smooth bore nozzles, is generally improved with the use of a stream straightener. A stream straightener is integrated into the exit of the monitor.

### 3.4 USE WITH FOAM

The Blitzfire may be used with various foam nozzles and foam solutions. Refer to fire service training for the proper use of foam.

### 3.5 USE WITH SALT WATER

Use with salt water is permissible provided the monitor is thoroughly cleaned with fresh water after each use. The service life of the monitor may be shortened due to the effects of corrosion and is not covered under warranty.

### 3.6 BLITZFIRE PRESSURE LOSS

Figure 3.6 gives the pressure loss for the Blitzfire Portable Monitor

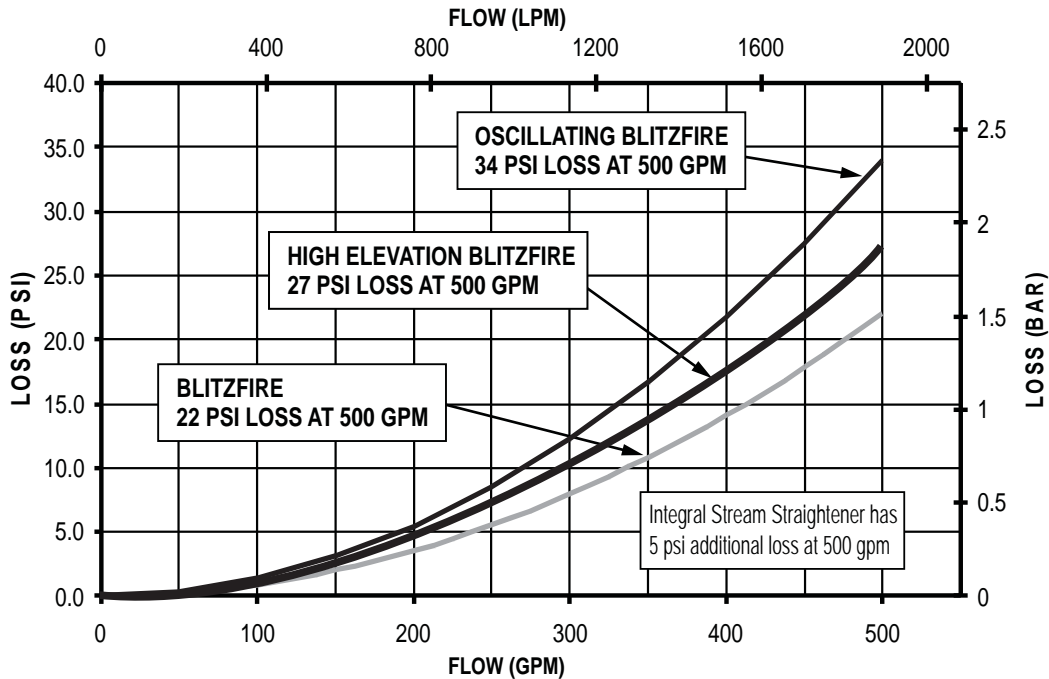

Figure 3.6 Blitzfire Pressure Loss

## 4.0 DEPLOYMENT OF BLITZFIRE

It is the responsibility of the individual fire department or agency to determine physical capabilities and suitability for an individual's use of this equipment.

### 4.1 CARRYING WITH AN UNCHARGED HOSE

On a preconnected hoseline the Blitzfire may be carried over the shoulder with the legs folded as illustrated in figure 4.1.



Figure 4.1 Carrying the Blitzfire on an Uncharged Hose

### 4.2 ADVANCING WITH A CHARGED HOSE

On a charged hose the Blitzfire may be advanced by holding the valve handle and one of the legs as shown in figure 4.2. Valve handle should be locked in the closed position to keep the valve from inadvertently opening.

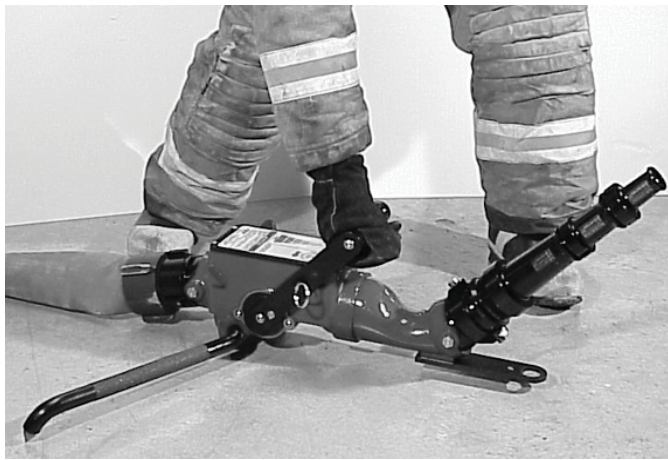

Figure 4.2 Advancing the Blitzfire with a Charged Hose

## 5.0 ANCHORING

The nozzle reaction force on the Blitzfire may be as high as 330 lbs - 500 GPM at 175 PSI (150 kg- 2000 LPM at 12 BAR). This nozzle reaction must be restrained to keep the monitor from moving.

The monitor should be anchored from moving by one or more of these methods:

| METHOD                            | RISK of MOVING |
|-----------------------------------|----------------|
| Anchoring by Weight               | High           |
| Anchoring by Spike Holds          | Medium         |
| Hooking legs on vertical surfaces | Medium         |
| Using a tie off strap             | Low            |

## 5.1 ANCHORING BY WEIGHT

On surfaces with good traction a person's weight on the monitor and/or hose may be sufficient to keep the monitor from moving. This is highly dependant on the friction of the surface. The ability to keep one or more than one person's weight on the monitor is subject to operator fatigue and may not be as reliable as other methods. Operating at limited flows will reduce the risk.

## 5.2 ANCHORING BY SPIKE HOLDS

Anchoring by spike holds is defined as intentionally placing one or more spikes into a crack, hole, or other hold to anchor the monitor from moving. On hard smooth surfaces such as ceramic tile, smooth concrete, marble, terrazzo, or steel decking the Blitzfire's spikes may not hold well. Placing the spikes into cracks, expansion joints, or gratings or the like will help hold the monitor from sliding. Even with the spikes anchored, sliding may be caused by the surface cracking under the load, or from the hose or nozzle moving the monitor thereby dislodging the spikes from their hold. Figure 4.3.1 shows a close up of a spike caught in a crack.

The holding ability of the spikes on soft surfaces such as sand, gravel and mud is generally poor, therefore other anchoring methods should be considered.

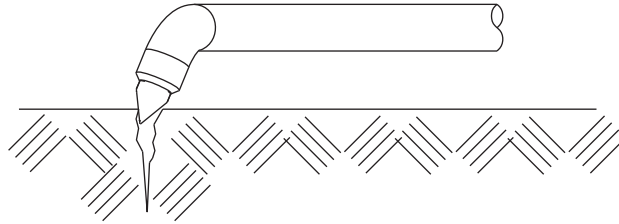
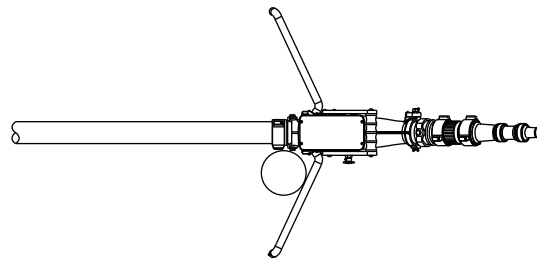

Figure 4.3.1 Spike Caught in a Crack

## 5.3 ANCHORING BY HOOKING LEGS

The legs on the Blitzfire point back slightly so they can act as a hook for anchoring on posts, walls, door frames or other fixed objects. Sliding can occur if the legs are unhooked due to the influence of the hose, nozzle, or operator. See figure 4.3.2 for illustrations of hooking the legs.



### Good

Nozzle reaction keeps leg hooked.  
Object is close to hose.

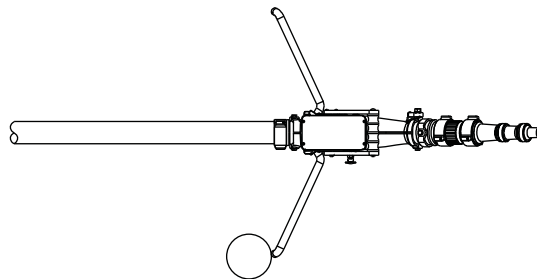

### Poor

Nozzle reaction tends to unhook leg

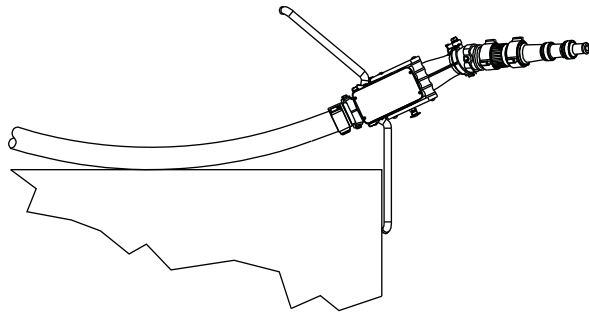

### Good

Nozzle reaction keeps leg hooked.  
Hose hits wall and helps hold position.

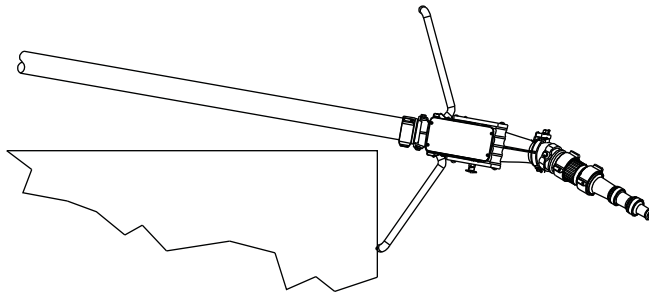

### Poor

Nozzle reaction tends to unhook leg.

Figure 5.3 Hooking Legs to Gain Support

## 5.4 ANCHORING BY TYING OFF

The safest method of restraining the monitor is to use a tie down strap. It is inherently more reliable than other methods since it does not rely on traction or digging in of the spikes. It is also the safest method because, even if the monitor moves, its travel is limited by the strap. A forward attachment point and a strap are provided with the Blitzfire. A loop on the end of the strap may be placed over the anchor point or the strap may be wrapped around an object, such as a tree, and the snap end of the strap passed through the loop and pulled tight. Keep the entire length of the strap as close to the ground as possible. Snap the hook into the hole in the front of the Blitzfire. If the strap is too short to reach a suitable anchor, it may be extended with strong rope or chain. Keep the distance between the Blitzfire and anchor as short as possible. Remove all slack between the Blitzfire and anchor before flowing water. Figure 4.3.3 shows the elements of tying off the monitor.

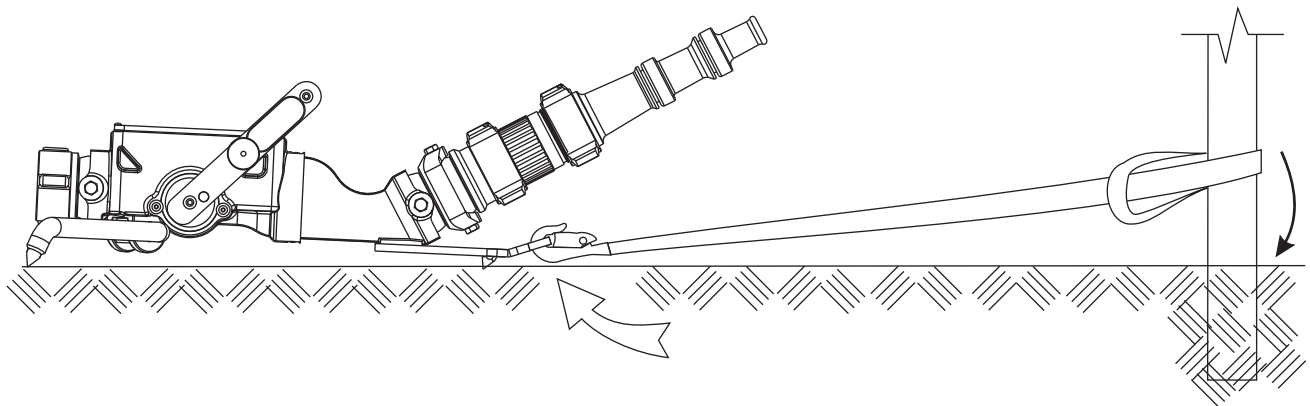

Figure 4.3.3 Tying Off of Blitzfire Monitor

## 6.0 OSC OSCILLATING UNIT

An automatic oscillating mechanism is available for the Blitzfire Monitor. The Blitzfire Monitor can be purchased with the oscillating mechanism factory installed or added at the factory later.

### 6.1 SAFETY - OSCILLATOR

#### **⚠ DANGER**

Do not attempt to modify this oscillating mechanism to fit any other monitor. To do so will cause the reaction force of the nozzle to be unaligned with the center of rotation. The monitor may spin very fast with a very high force.

#### **⚠ WARNING**

Keep hands and fingers away from the moving parts of the oscillating unit when water is flowing. There are moving parts that can pinch fingers and hands.

#### **⚠ WARNING**

Make sure the Blitzfire is on a firm surface with adequate holding power. As the nozzle goes back and forth, the reaction force is acting in different directions on the leg spikes. Surfaces such as asphalt, turf and dirt generally have good holding power. Surfaces like concrete and loose gravel hold poorly.

#### **⚠ CAUTION**

Because the nozzle attached to the Blitzfire must slow down, stop and reverse direction at the end of each sweep, the ends of the covered area will receive more water than the center. If the center area of coverage needs the most cooling, occasionally narrow the area of coverage or use the oscillator manually.

#### **⚠ CAUTION**

Because the oscillating mechanism is always moving, the monitor should be manned at all times. When oscillation is disengaged, be prepared for unintended movement of the nozzle.

### 6.2 GENERAL - OSCILLATOR

The Blitzfire oscillating mechanism can be used for exposure protection, cooling, or any other situation where it is desirable to have a monitor sweep back and forth.

The oscillating mechanism is driven by a turbine wheel. A worm gear drive reduces the speed and increases the torque of the turbine wheel. A simple crank mechanism makes the outlet of the Blitzfire and the nozzle attached to it move back and forth. The horizontal sweep can be set for a 20, 30 and 40 degree sweep. The oscillating mechanism can be uncoupled and the water stream can be aimed manually.

The speed of oscillation is a function of flow rate, see the Blitzfire Oscillation Speed graph on page 15. A minimum flow rate of 175 GPM is required for proper oscillator operation.

### 6.3 OSCILLATOR

Operating details for the Blitzfire Oscillator are shown in figure 6.3.

The Blitzfire's oscillator is protected by a shock absorber system. If the nozzle encounters an obstruction the shock absorber will compress or extend as needed to protect the gears from overload.

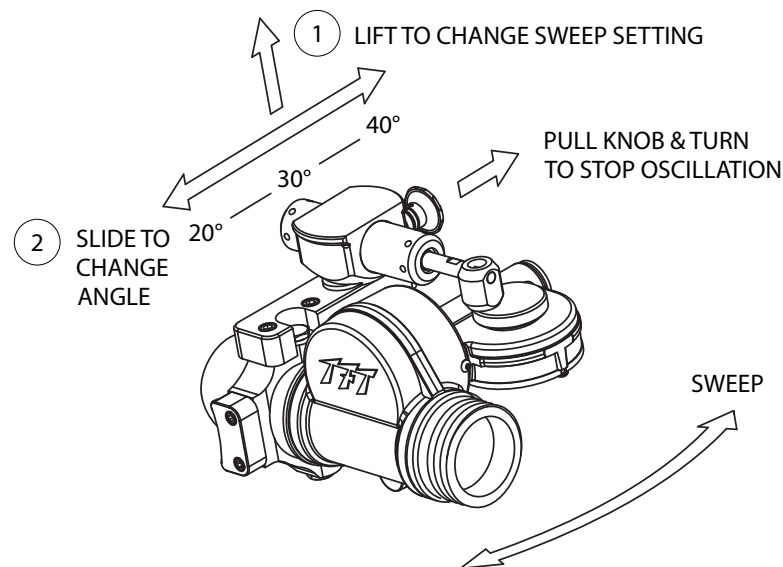

Fig. 6.3 Blitzfire Monitor Oscillator

## 6.4 OSCILLATION SPEED AND COVERAGE

Oscillation speed: The chart shows how many times per minute the oscillator makes one complete cycle as a function of flow. The higher the flow, the faster it oscillates.

For nozzle reach, refer to the operation manual for the specific nozzle. For reach with oscillation, subtract 20% from the distance.

| APPROXIMATE CYCLES/MIN | GPM | L/MIN |
|------------------------|-----|-------|
| 8                      | 175 | 650   |
| 13                     | 250 | 1000  |
| 21                     | 375 | 1500  |
| 28                     | 500 | 2000  |

**BLITZFIRE OSCILLATION SPEED**

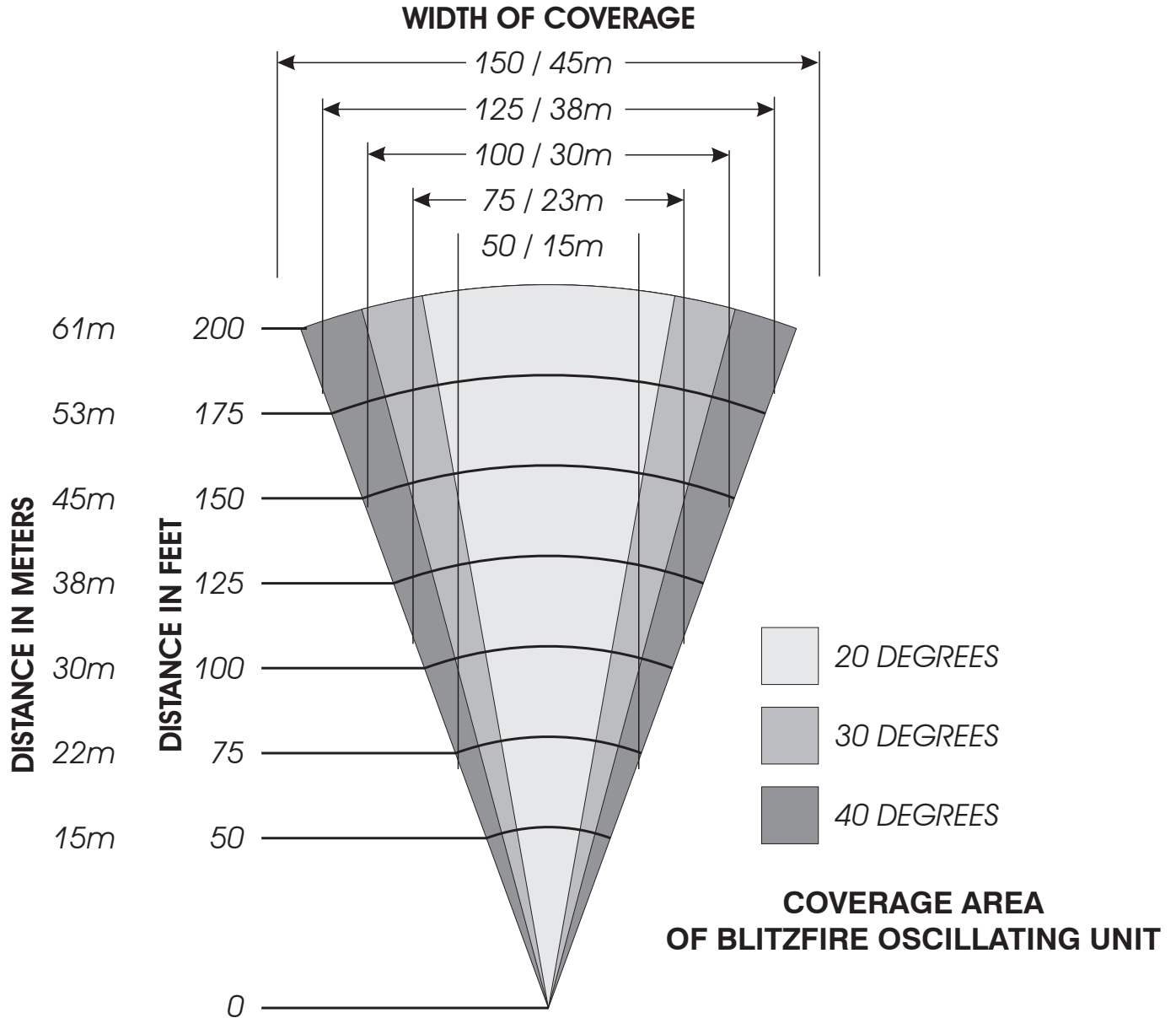

Fig. 6.4 Oscillation Speed and Coverage

### NOTICE

The type of nozzle and flow pressure are critical to the coverage area. The graph shows coverage area based on the movement capability of the oscillating mechanism. Actual coverage will depend on flow, pressure, type of nozzle, angle of fog pattern and wind conditions.



## 7.0 STORAGE

The monitor may be stored pre-connected to its hose on the optional storage bracket, TFT part number XX-B. The storage bracket may be mounted on a horizontal surface, or a vertical surface with the nozzle end pointing up or sideways. Mounting instructions are included with the bracket.

### **CAUTION**

**The storage bracket is not intended to support the nozzle reaction forces from a flowing monitor.**

## 8.0 MAINTENANCE

The Blitzfire monitor requires little maintenance. The unit should be kept clean and free of dirt by rinsing with water after each use. Any inoperable or damaged part should be repaired or replaced.

### **CAUTION**

**Any alterations to the Blitzfire and its markings could diminish safety and constitutes a misuse of this product.**

#### MAINTENANCE CHECK LIST:

- Safety shut-off valve is operational (see section 2.2.3)
- Valve label legible
- Legs pivot freely and detents hold folded or unfolded position
- Spikes are sharp. Replace if tip diameter exceeds 1/16 inch (1.6 mm).
- Inlet coupling rotates freely
- Inlet pivots freely up and down
- Pull pin for Valve Handle locking locks and releases easily
- Valve Handle moves smoothly without binding
- Valve Handle stays in detent positions
- Outlet pivots freely from side to side
- Outlet pivots freely upward
- Outlet pivot has sufficient drag to support weight of nozzle
- Tie down strap is in good condition; no frays on strap or damage to hook

## 9.0 WARRANTY

Task Force Tips, Inc., 3701 Innovation Way, Valparaiso, Indiana 46383-9327 USA ("TFT") warrants to the original purchaser of its Blitzfire Monitor ("equipment"), and to anyone to whom it is transferred, that the equipment shall be free from defects in material and workmanship during the five (5) year period from the date of purchase.

TFT's obligation under this warranty is specifically limited to replacing or repairing the equipment (or its parts) which are shown by TFT's examination to be in a defective condition attributable to TFT. To qualify for this limited warranty, the claimant must return the equipment to TFT, at 3701 Innovation Way, Valparaiso, Indiana 46383-9327 USA, within a reasonable time after discovery of the defect. TFT will examine the equipment. If TFT determines that there is a defect attributable to it, it will correct the problem within a reasonable time. If the equipment is covered by this limited warranty, TFT will assume the expenses of repair.

If any defect attributable to TFT under this limited warranty cannot be reasonably cured by repair or replacement, TFT may elect to refund the purchase price of the equipment, less reasonable depreciation, in complete discharge of its obligations under this limited warranty. If TFT makes this election, claimant shall return the equipment to TFT free and clear of any liens and encumbrances.

This is a limited warranty. The original purchaser of the equipment, any person to whom it is transferred, and any person who is an intended or unintended beneficiary of the equipment, shall not be entitled to recover from TFT any consequential or incidental damages for injury to person and/or property resulting from any defective equipment manufactured or assembled by TFT. It is agreed and understood that the price stated for the equipment is in part consideration for limiting TFT's liability. Some states do not allow the exclusion or limitation of incidental or consequential damages, so the above may not apply to you.

TFT shall have no obligation under this limited warranty if the equipment is, or has been, misused or neglected (including failure to provide reasonable maintenance) or if there have been accidents to the equipment or if it has been repaired or altered by someone else.

**THIS IS A LIMITED EXPRESS WARRANTY ONLY. TFT EXPRESSLY DISCLAIMS WITH RESPECT TO THE EQUIPMENT ALL IMPLIED WARRANTIES OF MERCHANTABILITY AND ALL IMPLIED WARRANTIES OF FITNESS FOR A PARTICULAR PURPOSE. THERE IS NO WARRANTY OF ANY NATURE MADE BY TFT BEYOND THAT STATED IN THE DOCUMENT.**

This limited warranty gives you specific legal rights, and you may also have other rights which vary from state to state.

Visit TFT's web site at [www.tft.com](http://www.tft.com)

## 10.0 EXPLODED VIEWS AND PARTS LISTS

### 10.1 SAFETY MECHANISM ASSEMBLY VIEW

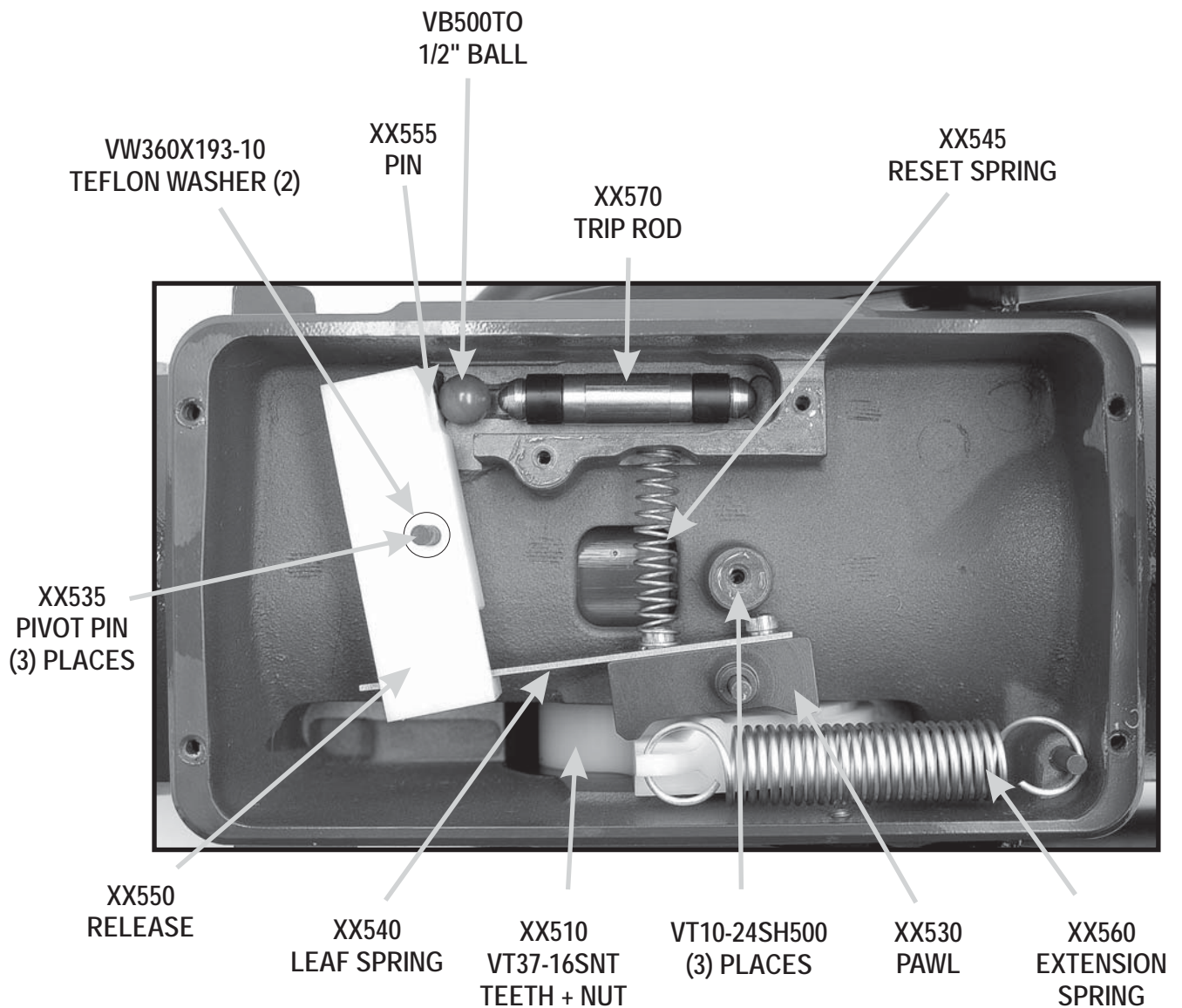

NOT SHOWN: XX520 RETAINER PLATE  
VP188X.38HDP SPIRAL PIN

## 10.2 BLITZFIRE MONITOR EXPLODED VIEW

FOR REPAIR INFORMATION ON THE  
AUTOMATIC SHUTOFF OR THE SLOW  
CLOSE MECHANISM, CONTACT  
TASK FORCE TIPS AT 800-348-2686.

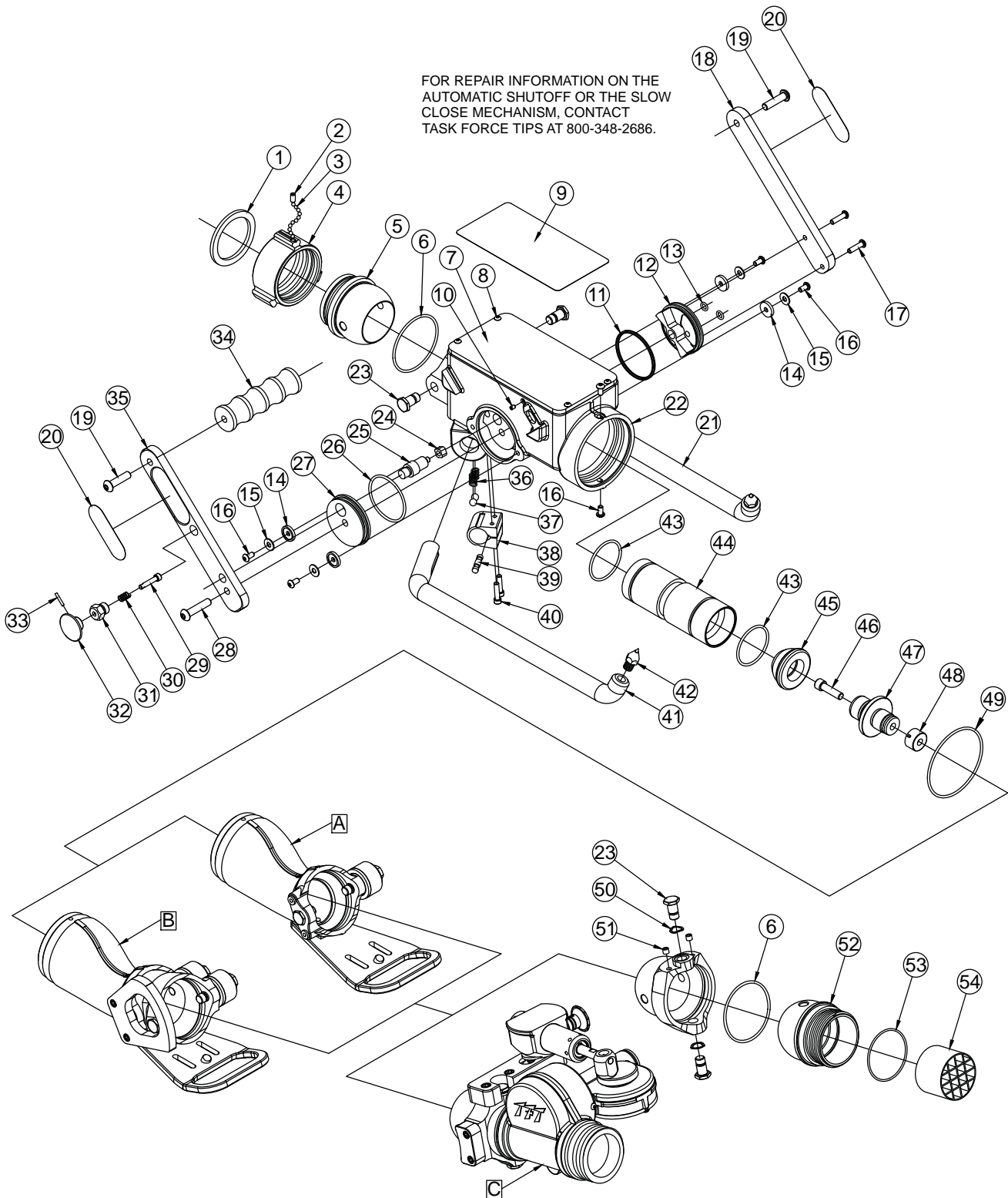

## 10.2 BLITZFIRE MONITOR EXPLODED VIEW PARTS LIST

| INDEX | DESCRIPTION                      | QTY | ITEM #       |
|-------|----------------------------------|-----|--------------|
| 1     | GASKET 2.5"                      | 1   | V3190        |
| 2     | 1/4-28 X 1/2 SOCKET SET SCREW    | 1   | VT25-28SS500 |
| 3     | 3/16" SS BALL                    | 48  | V2120        |
| 4     | COUPLING 2.5"                    | 1   | M307*        |
| 5     | INLET SWIVEL                     | 1   | XX605        |
| 6     | O-RING-235                       | 1   | VO-235       |
| 7     | COVER PLATE                      | 1   | XX205        |
|       | COVER PLATE GASKET               | 1   | XX200        |
| 8     | 10-24 1/2 BUTTON HEAD SCREW      | 4   | VT10-24BH500 |
| 9     | INSTRUCTION LABEL                | 1   | XL670        |
| 10    | 10-24 X 1/4 SOCKET SET SCREW     | 1   | VT10-24SS250 |
| 11    | QUAD-RING-231                    | 1   | VOQ-4231     |
| 12    | DRAG DISK                        | 1   | XX645        |
| 13    | O-RING-109                       | 2   | VO-109       |
| 14    | DISC RETAINER                    | 4   | XX642        |
| 15    | WASHER                           | 4   | VW687X281-50 |
| 16    | 1/4-28 X 1/2 BUTTON HEAD SCREW   | 6   | VT25-28BH500 |
| 17    | 1/4-20 X 1 BUTTON HEAD SCREW     | 2   | VT25-20BH1.0 |
| 18    | LEFT HANDLE                      | 1   | XX621        |
| 19    | 3/8-16 X 1-1/2 BUTTON HEAD SCREW | 2   | VT37-16BH1.5 |
| 20    | HANDLE LABEL                     | 2   | XL620        |
| 21    | LEFT LEG                         | 1   | XX470L       |
| 22    | BODY                             | 1   | XX600        |
|       | TRIP MECHANISM                   | 1   | XX910        |
| 23    | SWIVEL TRUNNION                  | 2   | XX320        |
| 24    | SQUARE BUSHING                   | 1   | XX630        |
| 25    | CAM PIN                          | 1   | XX610        |
| 26    | O-RING-230 TEFLON                | 1   | VO-230T      |
| 27    | DISK                             | 1   | XX640        |
| 28    | 3/8-16 X 1.7 BUTTON HEAD SCREW   | 1   | VT37-16BH1.7 |
| 29    | PULL PIN                         | 1   | XX343        |

| INDEX | DESCRIPTION                         | QTY | ITEM #           |
|-------|-------------------------------------|-----|------------------|
| 30    | PULL PIN SPRING                     | 1   | XX342            |
| 31    | PULL PIN HOUSING                    | 1   | XX355            |
| 32    | PULL KNOB                           | 1   | XX341            |
| 33    | 1/8 X 3/4 HDP SPIROL PIN            | 1   | VP125X750H       |
| 34    | HANDLE TOP                          | 1   | XX625            |
| 35    | RIGHT HANDLE                        | 1   | XX620            |
| 36    | DETENT SPRING                       | 4   | XX655            |
| 37    | 3/8" TORLON BALL                    | 4   | VB375TO          |
| 38    | LEG RETAINER                        | 2   | XX475            |
| 39    | LEG RETAINER PIN                    | 2   | XX476            |
| 40    | 1/4-20 X 1 SOCKET HEAD SCREW        | 4   | VT25-20SH1.0     |
| 41    | RIGHT LEG                           | 1   | XX470R           |
| 42    | REAR SPIKE                          | 2   | X482             |
| 43    | O-RING-227                          | 2   | VO-227           |
| 44    | SLIDER                              | 1   | XX660            |
| 45    | VALVE PLUG                          | 1   | XX590            |
| 46    | 3/8-24 X 1-3/4 SOCKET HEAD SCREW    | 1   | VT37-24SH175     |
| 47    | PLUG SUPPORT                        | 1   | XX594            |
| 48    | LOCKING SLEEVE                      | 1   | XX571            |
| 49    | O-RING-241                          | 1   | VO-241           |
| 50    | WAVE SPRING WASHER                  | 2   | VW740X550-16     |
| 51    | 5/16-18 X 1/4 SOCKET SET SCREW      | 2   | VT31-18SS250     |
| 52    | EXIT 2.5"                           | 1   | XX310*           |
| 53    | O-RING-147                          | 1   | VO-146           |
| 54    | STREAM STRAIGHTENER INSERT          | 1   | V4040            |
| A     | BLITZFIRE OUTLET                    | 1   | SEE SECTION 10.3 |
| B     | HIGH ELEVATION BLITZFIRE OUTLET     | 1   | SEE SECTION 10.4 |
| C     | HIGH ELEVATION BLITZFIRE OSCILLATOR | 1   | SEE SECTION 10.5 |

\* - CONSULT FACTORY FOR SPECIAL THREADS

### 10.3 STANDARD BLITZFIRE OUTLET EXPLODED VIEW

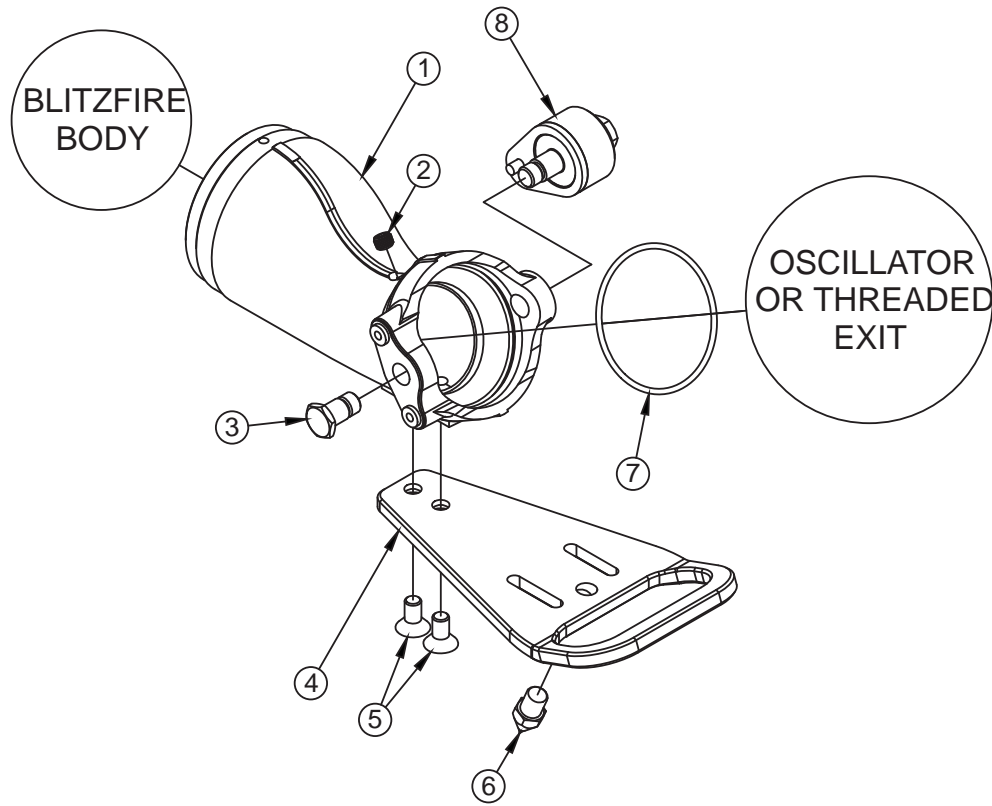

### 10.3 BLITZFIRE OUTLET [A] PARTS LIST

| INDEX | DESCRIPTION                         | QTY | ITEM #       |
|-------|-------------------------------------|-----|--------------|
| 1     | OUTLET                              | 1   | XX420        |
| 2     | 1/8 NPT PLUG                        | 1   | VFSP1M SS    |
| 3     | SWIVEL TRUNNION                     | 3   | XX320        |
| 4     | FRONT LEG                           | 1   | XX460        |
| 5     | 3/8-16 X 1/2 FLAT HEAD SOCKET SCREW | 2   | VT37-16FH750 |
| 6     | SPIKE                               | 1   | X480         |
| 7     | O-RING-235                          | 1   | VO-235       |
| 8     | RATCHET CLUTCH                      | 1   | XX830-KIT    |

## 10.4 HIGH ELEVATION BLITZFIRE OUTLET EXPLODED VIEW

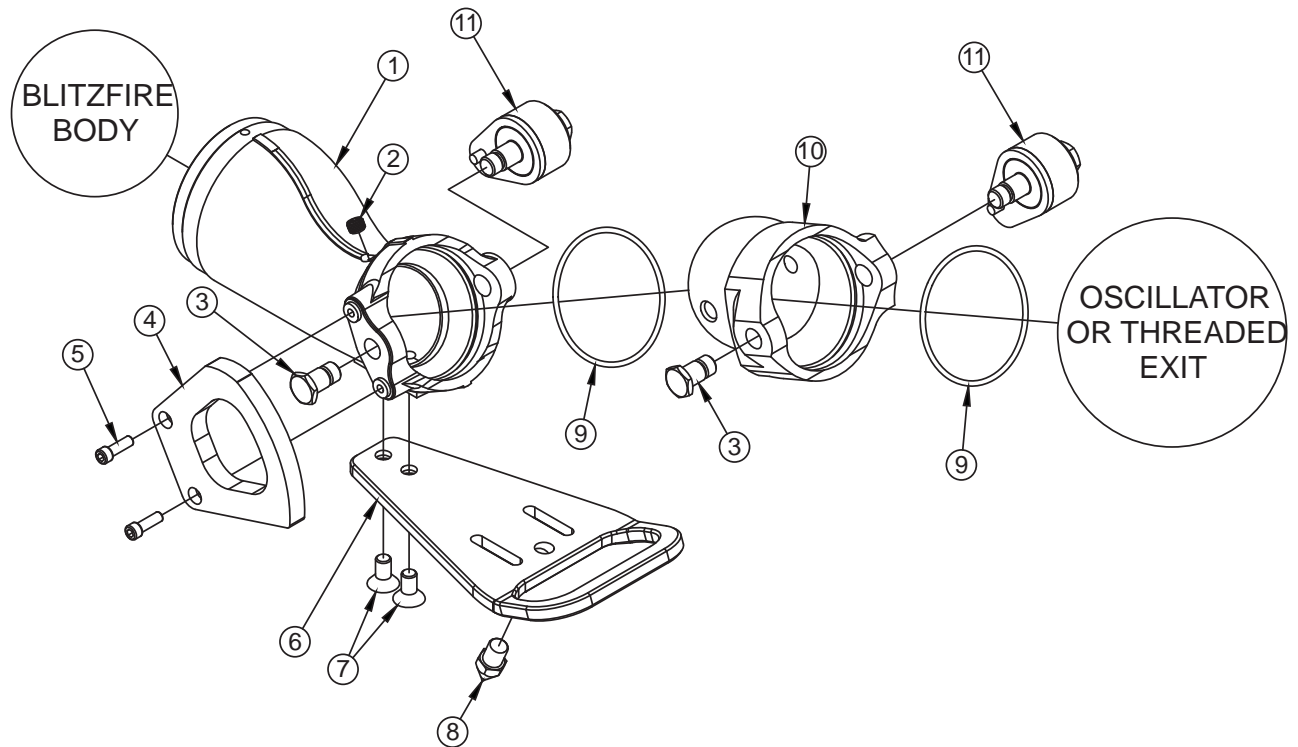

## 10.4 HIGH ELEVATION BLITZFIRE OUTLET [B] PARTS LIST

| INDEX | DESCRIPTION                         | QTY | ITEM #       |
|-------|-------------------------------------|-----|--------------|
| 1     | OUTLET                              | 1   | XX420        |
| 2     | 1/8 NPT PLUG                        | 1   | VFSP1M SS    |
| 3     | SWIVEL TRUNNION                     | 4   | XX320        |
| 4     | CAM                                 | 1   | XX322        |
| 5     | 1/4-20 X 1 SOCKET HEAD SCREW        | 4   | VT25-20SH1.0 |
| 6     | FRONT LEG                           | 1   | XX460        |
| 7     | 3/8-16 X 1/2 FLAT HEAD SOCKET SCREW | 2   | VT37-16FH750 |
| 8     | SPIKE                               | 1   | X480         |
| 9     | O-RING-235                          | 3   | VO-235       |
| 10    | 1ST SEGMENT                         | 1   | XX306        |
| 11    | RATCHET CLUTCH                      | 2   | XX830-KIT    |

# 10.5 BLITZFIRE OSCILLATOR EXPLODED VIEW

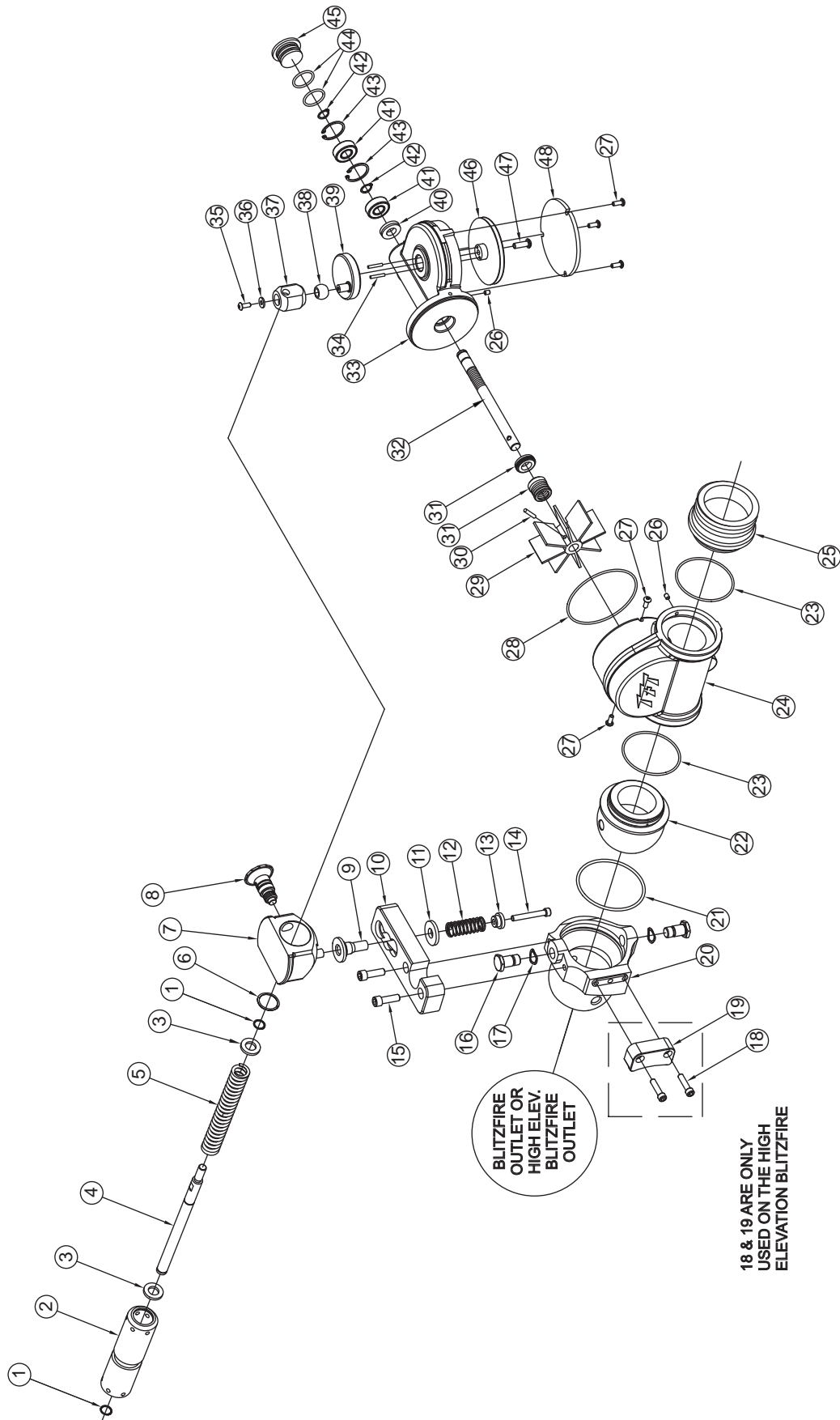

BLITZFIRE  
OUTLET OR  
HIGH ELEV.  
BLITZFIRE  
OUTLET

18 & 19 ARE ONLY  
USED ON THE HIGH  
ELEVATION BLITZFIRE



## 10.5 OSCILLATOR [C] PARTS LIST

| INDEX                                   | DESCRIPTION                     | QTY | ITEM #       |
|---|---------------------------------|-----|--------------|
| 1                                       | SMALLEY RING                    | 2   | V4280        |
| 2                                       | SPRING TUBE                     | 1   | XX367        |
| 3                                       | WASHER                          | 2   | XX364        |
| 4                                       | LINK                            | 1   | XX363        |
| 5                                       | SPRING                          | 1   | XX371        |
| 6                                       | SMALLEY RING                    | 1   | VR4340       |
| 7                                       | SLIDER BLOCK                    | 1   | XX368        |
| 8                                       | LATCHING PULL PIN SUBASSEMBLY   | 1   | XX935        |
| 9                                       | DETENT BUSHING                  | 1   | XX376        |
| 10                                      | ARM                             | 1   | XX061        |
| 11                                      | WASHER                          | 1   | XX377        |
| 12                                      | SPRING                          | 1   | C031         |
| 13                                      | SPRING RETAINER                 | 1   | XX378        |
| 14                                      | 1/4-20 X 1.75 SOCKET HEAD SCREW | 1   | VT25-20SH1.7 |
| 15                                      | 5/16-18 X 1 SOCKET HEAD SCREW   | 2   | VT31-18SH1.0 |
| 16                                      | SWIVEL TRUNNION                 | 2   | XX320        |
| 17                                      | WAVE SPRING WASHER              | 2   | VW740X550-16 |
| 18                                      | 1/4-20 X 1 SOCKET HEAD SCREW    | 2   | VT25-20SH1.0 |
| 19                                      | CAM FOLLOWER                    | 1   | XX323        |
| 20                                      | 2ND SEGMENT                     | 1   | XX307        |
|   | EXIT SEGMENT                    |     | XX305        |
| 21                                      | O-RING-235                      | 1   | VO-235       |
| 22                                      | INLET BALL                      | 1   | XX015        |
| 23                                      | O-RING-147                      | 2   | VO-147       |
| 24                                      | WATERWAY                        | 1   | XX010        |
| 25                                      | EXIT OSC 2.5"                   | 1   | XX020*       |
| 26                                      | 10-32 X 1/4 SOCKET SET SCREW    | 3   | VT10-32SS250 |
| 27                                      | 10-32 X 1/2 BUTTON HEAD SCREW   | 5   | VT10E32BH500 |
| 28                                      | O-RING-153                      | 1   | VO-153       |
| 29                                      | TURBINE VANES                   | 1   | XX025        |
| 30                                      | 5/32 X 7/8 HDP SPIROL PIN       | 1   | V1900        |
| 31                                      | TURBINE SEAL                    | 1   | XX032        |
| 32                                      | WORM AND SHAFT                  | 1   | XX030        |
| 33                                      | GEAR BOX                        | 1   | XX005        |
| 34                                      | 1/8 X 3/4 HDP SPIROL PIN        | 2   | VP125X750H   |
| 35                                      | BUTTON HEAD CAP SCREW           | 1   | VT10-32BH500 |
| 36                                      | WASHER                          | 1   | VW500X203-60 |
| 37                                      | OFFSET ROD END                  | 1   | XX057        |
| 38                                      | SPHERICAL BUSHING               | 1   | XX058        |
| 39                                      | CRANK                           | 1   | XX362        |
| 40                                      | CUP SEAL                        | 1   | XX033        |
| 41                                      | WORM SHAFT BEARING              | 2   | XX035        |
| 42                                      | SNAP RING 1/2" EXTERNAL         | 2   | VR4250       |
| 43                                      | SNAP RING 1-1/8 INTERNAL        | 2   | VR4255       |
| 44                                      | O-RING-119                      | 2   | VO-119       |
| 45                                      | SHAFT CAP                       | 1   | XX037        |
| 46                                      | WORM GEAR                       | 1   | XX040        |
| 47                                      | 1/4-20 X 7/8 SOCKET HEAD SCREW  | 1   | VT25-20SH875 |
| 48                                      | COVER                           | 1   | XX045        |
| * - CONSULT FACTORY FOR SPECIAL THREADS |                                 |     |              |

## 11.0 OPERATION CHECKLIST

Monitor must be inspected for proper operation and function according to this checklist before each use. Before flowing water check:

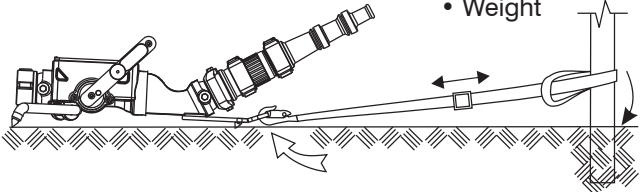
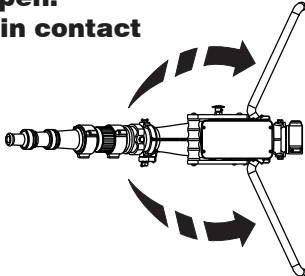
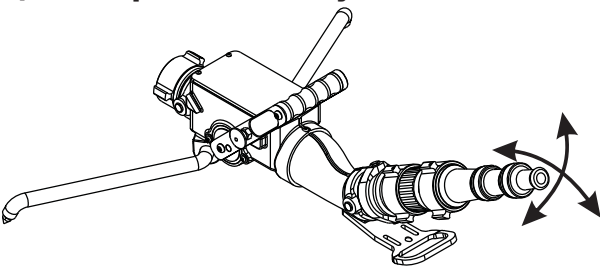
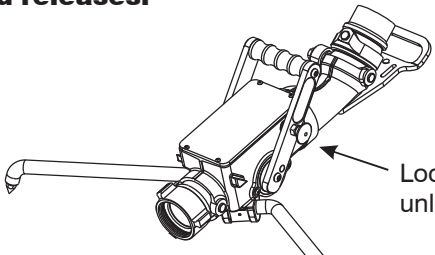
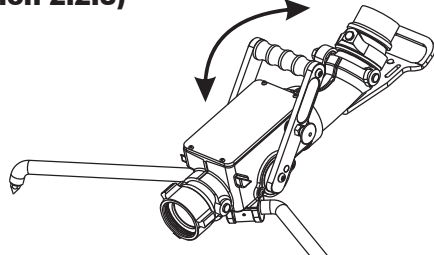
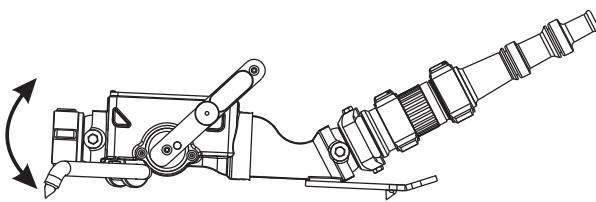
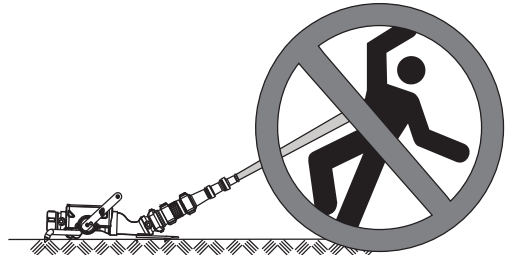
|  |   |
|--|---|
| <p><b>1) There is no obvious damage such as missing, broken or loose parts.</b><br/> <b>2) Hose and nozzle are securely attached.</b></p>  | <p><b>7) Monitor is anchored:</b></p> <ul style="list-style-type: none"> <li>• Tied off</li> <li>• Hooked leg</li> <li>• Spike hold</li> <li>• Weight</li> </ul>  |
| <p><b>3) Both legs are fully open.</b><br/> <b>4) All three spikes are in contact with the ground.</b></p>          | <p><b>8) Outlet pivots smoothly in all directions.</b></p>    |
| <p><b>5) Valve handle locks when closed and releases.</b></p>  <p style="text-align: right;">Locks and unlocks</p> | <p><b>9) Safety Shut-Off valve is operational.</b><br/>         (see section 2.2.3)</p>    |
| <p><b>6) Inlet pivots freely.</b></p>   | <p><b>10) Monitor is pointed in a safe direction.</b></p>   |

### **⚠ WARNING**

Any Blitzfire monitor failing any part of the inspection checklist is unsafe and must have the problem corrected before use. Operating a Blitzfire that fails any of the above inspections is a misuse of this equipment.

**TASK FORCE TIPS, INC.**  
 MADE IN USA • [www.tft.com](http://www.tft.com)

3701 Innovation Way, Valparaiso, IN 46383-9327 USA  
 800-348-2686 • 219-462-6161 • Fax 219-464-7155