

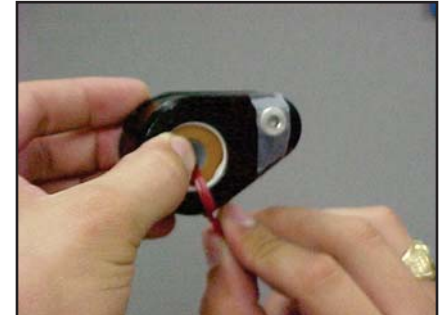

**TASK FORCE TIPS**

# BLITZFIRE Clutch Replacement

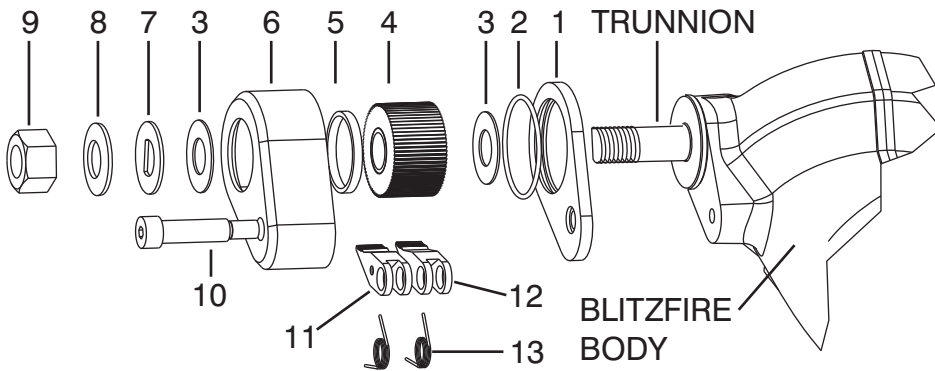

**Step 5**

| KEY | DESCRIPTION     | QTY | TFT PART #   |
|-----|-----------------|-----|--------------|
| 1   | CLUTCH BASE     | 1   | XX336        |
| 2   | O-RING-027      | 1   | VO-027       |
| 3   | PHENOLIC WASHER | 2   | VW1.0X500-03 |
| 4   | RATCHET         | 1   | XX333        |
| 5   | DIRT SEAL       | 1   | XX339        |
| 6   | CLUTCH HOUSING  | 1   | XX337        |

| KEY | DESCRIPTION            | QTY | TFT PART #   |
|-----|------------------------|-----|--------------|
| 7   | D-WASHER               | 1   | XX350        |
| 8   | BELLEVILLE WASHER      | 1   | VW1.0X512-BV |
| 9   | 1/2-20 HEX NUT         | 1   | VT50-20NT    |
| 10  | 5/16 X 1 SHOULDER BOLT | 1   | VT31-00SB1.0 |
| 11  | PAWL 40 DEGREE         | 1   | XX331        |
| 12  | PAWL 37-1/2 DEGREE     | 1   | XX332        |
| 13  | TORSION SPRING         | 2   | XX338        |

- 1) Remove the Button Head Cap Screw on the clutch, which is found on the elevation joint, on the left side of the Blitzfire.
- 2) Remove the 1/2" Nut, Belleville Spring, and D-Washer from the clutch.
- 3) Remove and discard the Clutch assembly and the previously removed parts. Wipe the face of the flange and the shank of the Clutch Trunnion with a clean dry rag.
- 4) Put a drop of BLUE Loctite® on the thread of the Socket Head Screw in the new Clutch Assembly.
- 5) Hold the new Ratchet Clutch assembly with the thumb of your left hand on the Phenolic washer on the side of the clutch that has the bolt head, and your index finger on the Phenolic washer on the other side. Hold all the parts together and remove the shipping band.
- 6) Carefully slide the entire unit as a whole over the Trunnion on the Blitzfire. DO NOT PUSH IT ON

ALL THE WAY. Align the Socket Head Screw with the threads in the Blitzfire casting. Push a 5/32 Allen wrench through the tape on the screw head and screw the screw in all the way but do not tighten it. Remove the tape remnants.

- 7) Put the D-Washer over the Phenolic Washer in the new assembly, put the Belleville Spring on top of the D-Washer with the concave side toward the Blitzfire body. Screw on the 1/2" Nut finger tight.
- 8) Now tighten the Socket Head Screw which holds the assembly to the body.
- 9) Torque 1/2" clutch nut to minimum of 95 in/lbs. If torque wrench is unavailable, attach the nozzle that will be used most often on the Blitzfire. Open the legs and set the Blitzfire on a flat surface and lift the nozzle to full elevation. If the nozzle drops, tighten the 1/2 " nut 1/6th turn. Repeat until the nozzle remains in place with out falling.

**TASK FORCE TIPS, Inc.**  
MADE IN USA • www.tft.com

3701 Innovation Way, Valparaiso, IN 46383-9327 USA  
800-348-2686 • 219-462-6161 • Fax 219-464-7155