



**TASK FORCE TIPS**  
FIRE FIGHTING EQUIPMENT

# EXTEND-A-GUN™ RC3 & RC4

Telescoping Waterway for Deck Mounted Monitors

## INSTALLATION and OPERATING INSTRUCTIONS

### **⚠ DANGER**

Read instruction manual before use. Operation of this device without understanding the manual and receiving proper training is a misuse of this equipment. A person who has not read and understood all operating and safety instructions, is not qualified to operate the Extend-A-Gun RC3 or RC4 telescoping unit.

#### CONTROL BOX

(complete with 10 ft (3m) of power & communication cable for connection to monitor communication link & power, 10 ft (3m) of cable for connection to RC monitor, and 12 ft (3.6m) of cable for connection to RC Extend-A-Gun motor)

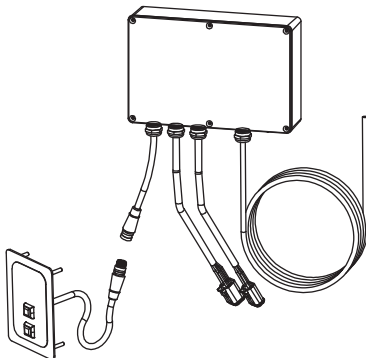

#### PUSHBUTTON STATION

(complete with 12 ft (3.6m) cable for connection to control box)

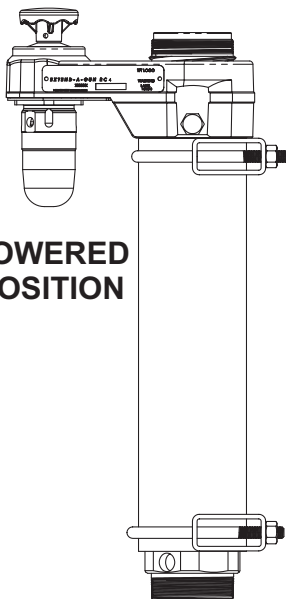

**LOWERED POSITION**

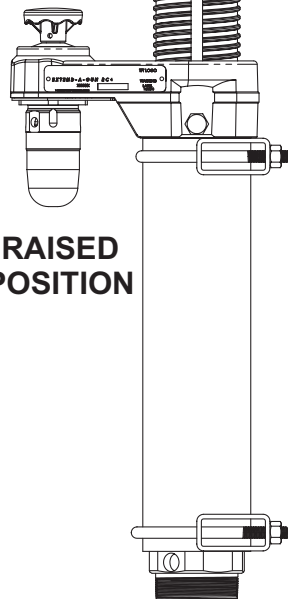

**RAISED POSITION**

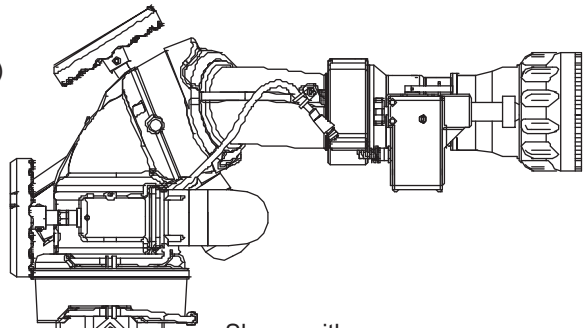

Shown with Monsoon RC Monitor and Master Stream 2000 Nozzle. (Monitor, Nozzle and Mounting Brackets not included)

**TASK FORCE TIPS, Inc.**  
Made in USA • [www.tft.com](http://www.tft.com)

2800 E Evans Ave • Valparaiso, IN 46383-6940 USA  
800-348-2686 • 219-462-6161 • Fax 219-464-7155

## TABLE OF CONTENTS

1.0 Meaning Of Signal Words	11.0 Use Of Drain
2.0 Safety	12.0 Operating Instructions
3.0 General Information	12.1 Extend
3.1 Specifications	12.2 Retract
3.2 Parts Identification	12.3 Manual Override
3.3 Dimensions	12.4 Indicator Light
4.0 Bracket Sets	12.5 Operation Below Freezing Temperatures
4.1 Selection Of Structural Support On Fire Trucks	12.6 Continuous Operations
4.2 Tube Bracket Installation	12.7 Current Limiting
4.3 Saddle Bracket Installation	13.0 Trouble Shooting
4.4 Plate Bracket Installation	14.0 Maintenance
5.0 Side Loads At Mounting Points	14.1 Lubrication Chart
5.1 12" Extend-A-Gun RC3	15.0 Exploded View & Parts List
5.2 18" Extend-A-Gun RC3 & RC4	16.0 Warranty
6.0 Manual Override	
6.1 Repositioning Override Knob	
7.0 Control Box Installation	
7.1 Control Box Mounting	
7.2 Panel Mount Operator Station Mounting	
7.3 Control Box Wiring	
7.4 Electrical Testing	
7.4.1 Verify Proper Voltage	
7.4.2 Set Travel Stops	
7.5 AUX1 Button Overlay	
8.0 Indicator Switch Wiring	
9.0 Labels	
10.0 Mounting Monitors	
10.1 Hurricane And Monsoon	
10.2 Crossfire® On Extend-a-gun RC3	

### **DANGER**

#### PERSONAL RESPONSIBILITY CODE

The member companies of FEMSA that provide emergency response equipment and services want responders to know and understand the following:

1. Firefighting and Emergency Response are inherently dangerous activities requiring proper training in their hazards and the use of extreme caution at all times.
2. It is your responsibility to read and understand any user's instructions, including purpose and limitations, provided with any piece of equipment you may be called upon to use.
3. It is your responsibility to know that you have been properly trained in Firefighting and /or Emergency Response and in the use, precautions, and care of any equipment you may be called upon to use.
4. It is your responsibility to be in proper physical condition and to maintain the personal skill level required to operate any equipment you may be called upon to use.
5. It is your responsibility to know that your equipment is in operable condition and has been maintained in accordance with the manufacturer's instructions.
6. Failure to follow these guidelines may result in death, burns or other severe injury.



Fire and Emergency Manufacturers and Services Association, Inc.  
P.O. Box 147, Lynnfield, MA 01940 • www.FEMSA.org

### 1.0 MEANING OF SIGNAL WORDS

A safety related message is identified by a safety alert symbol and a signal word to indicate the level of risk involved with a particular hazard. Per ANSI standard Z535.4-1998 the definitions of the three signal words are as follows:

 **DANGER**

**DANGER** indicates an imminently hazardous situation which, if not avoided, will result in death or serious injury.

 **WARNING**

**WARNING** indicates a potentially hazardous situation which, if not avoided, could result in death or serious injury.

 **CAUTION**

**CAUTION** indicates a potentially hazardous situation which, if not avoided, may result in minor or moderate injury.

## 2.0 SAFETY

### **⚠ DANGER**

Do not use AC current to operate the Extend-A-Gun RC. The Extend-A-Gun RC is a 12 or 24 volt DC system ONLY! Using the wrong power source could cause electrocution, resulting in death or serious injury.

### **⚠ WARNING**

Reaction forces generated by master stream flows are very powerful and capable of causing injury and property damage. The Extend-A-Gun RC must be securely mounted to rigid truck support members. Qualified persons should determine suitable mounting locations

### **⚠ WARNING**

Qualified individuals should conduct mounting bracket installation. Inferior welding or poor plate installation could result in serious injury or equipment damage.

### **⚠ WARNING**

Keep the upper and lower brackets as far apart as possible to minimize the amount of stress on the upper and lower brackets.

### **⚠ WARNING**

The forces acting on the mounting brackets, when the Extend-A-Gun RC is in the extended position, are higher than the forces in a normal deck gun installation. Failure to properly secure the Extend-A-Gun RC, could result in damaged equipment and serious injury.

### **⚠ WARNING**

Master stream flows are very powerful and capable of causing injury and property damage. Make sure the monitor is pointing in a safe direction before water to the monitor is turned on. Use care in directing the stream.

### **⚠ CAUTION**

Clear all personnel and obstructions away from the Extend-A-Gun RC before lowering. The electric motor is capable of producing up to 70 lbs of crushing force in the down stroke which may result in a crushing injury.

### **⚠ CAUTION**

The Extend-A-Gun RC has current limiting capabilities which stops the motor if an obstruction is encountered. The Extend-A-Gun RC must be installed as instructed using the correct controls and electrical boxes. Failure to do so will result in damage to the electric motor and loss of current limiting controls. This may result in injury.

### **⚠ CAUTION**

The Extend-A-Gun RC may be used in either the raised or the lowered position, but not in-between. The seal may become damaged if the water is turned on in any position other than fully extended or retracted.

### **⚠ CAUTION**

Do not plug or cap the Extend-A-Gun RC or mounted deck gun while it is in the raised position. This will prevent the Extend-A-Gun RC from being lowered to the park/stow position. Damage may occur if the truck drives under a low hanging object, while the Extend-A-Gun RC is extended.

## 3.0 GENERAL INFORMATION

The Extend-A-Gun RC lets you lower your deck mounted master stream device to deck level for storage (or even into a well). On the fire ground, the monitor can be automatically raised to its extended position (18 extra inches or 45.7 extra cm) with a simple push of a button. This gives greater clearance of other equipment on the apparatus, greater freedom of movement, and keeps firefighters off the top of the trucks, thus providing a safer operating position. The Extend-A-Gun RC offers a full 360 degree monitor rotation in either the raised or lowered position, large waterway, Hardcoat anodized aluminum finish. Built in sensor for connection to "monitor raised" light. Waterproof 12VDC electric drive, motor control box, and panel mount operator station for recessed mounting complete with cables and plugs for connecting TFT RC monitor and RC Extend-A-Gun. 24VDC operation requires 24-12VDC converter. Connecting RC Extend-A-Gun motor control box to RC monitor communication link (blue & white wires) allows RC Extend-A-Gun operation from any monitor operator station equipped with AUX1 button or input. Can be specified with new or retrofitted to existing apparatus.

### 3.1 SPECIFICATIONS

MODEL	EXTEND-A-GUN RC3	EXTEND-A-GUN RC4
Waterway Size	3" (76mm)	4" (102mm)
Max Flow	1250gpm (4800l/m)	2000 gpm (7600 l/min)
Max Pressure	200psi (13.8 bar)	200 psi (13.8 bar)
Lifting Capabilities	200 lbs (91kg)	200 lbs (91kg)
Crush Load	70 lbs (32kg)	70 lbs (32kg)
Lifting Speed	15 sec	15 sec
Lowering Speed	30 sec	30 sec
Voltage	12 volt DC	12 volt DC
Current Draw Lifting	10 amps running	10 amps running
	17.5 amps current limiting	17.5 amps current limiting
Current Draw Lowering	8 amps running	8 amps running
	15 amps current limiting	15 amps current limiting
Travel	18" (457mm)	18" (457mm)

### 3.2 PARTS IDENTIFICATION

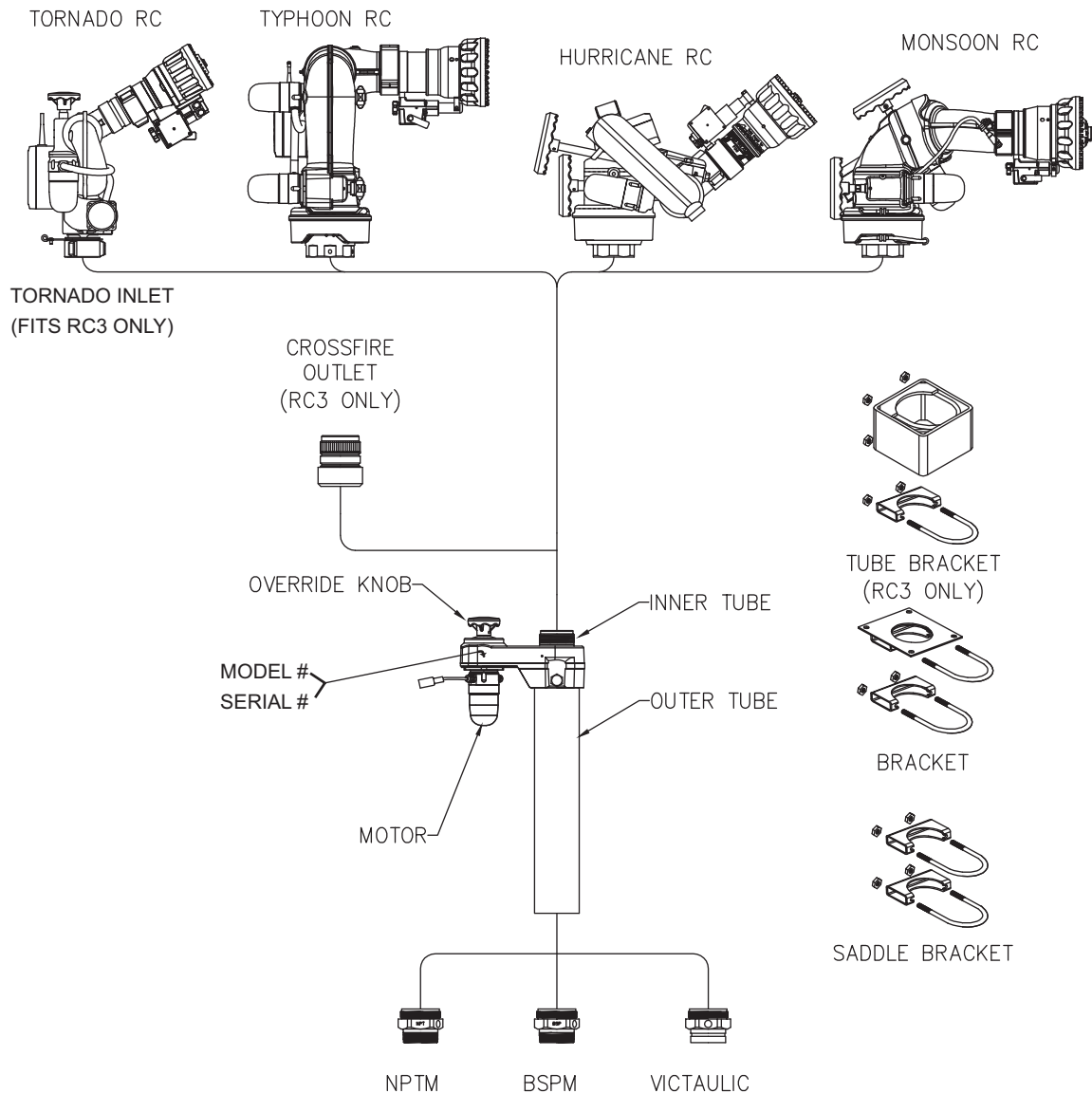

3.3 DIMENSIONS

# 12" EXTEND-A-GUN RC3 3" Waterway

SHOWN WITH  
TFT MASTER 1250 ER NOZZLE  
AND  
HURRICANE RC MONITOR

\*\* - OUTLETS SHOWN ARE  
FOR HURRICANE RC MODELS.  
FOR CROSSFIRE MODELS,  
SUBTRACT 1" 3/4

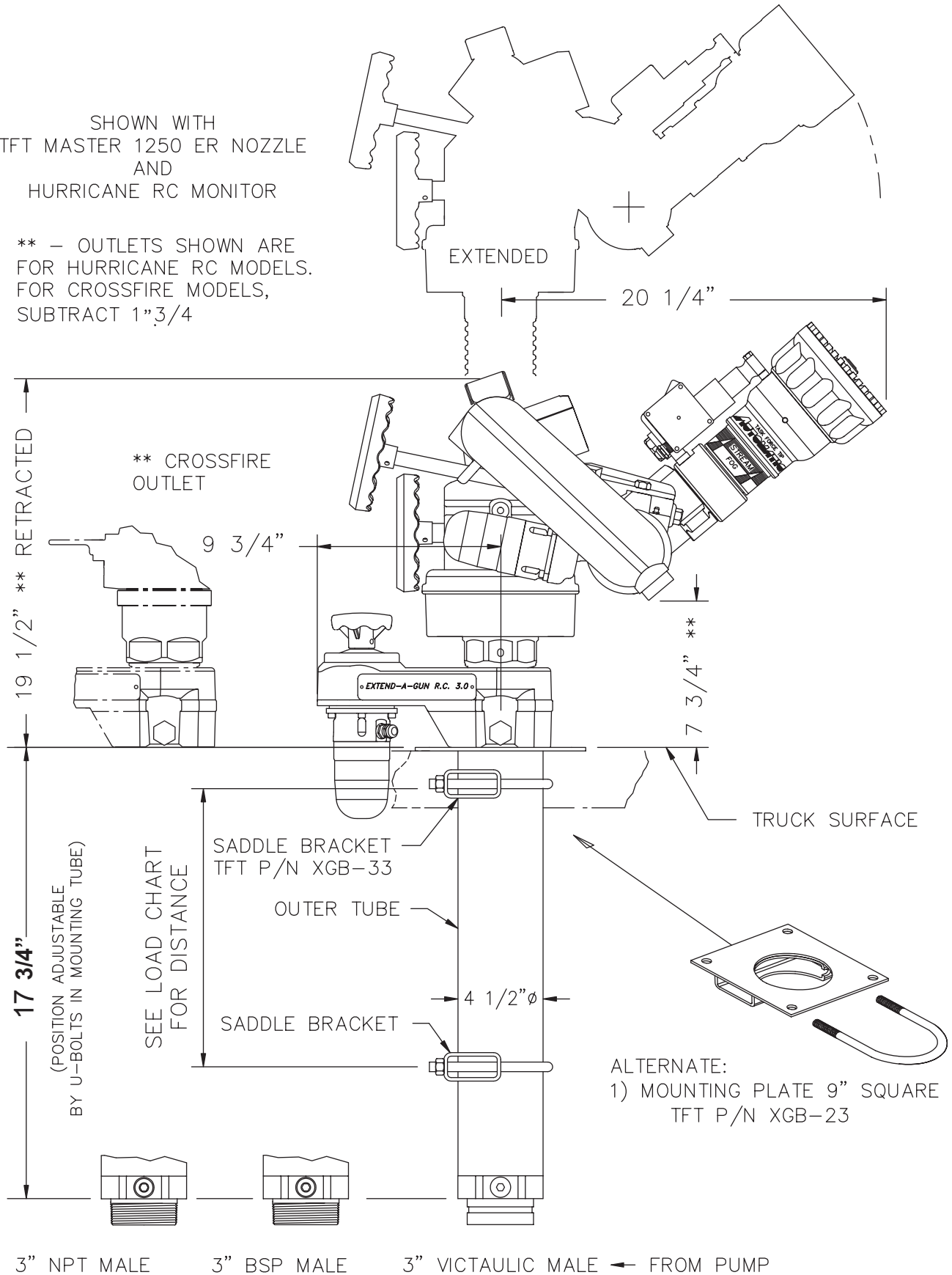

# 18" EXTEND-A-GUN RC3 3" Waterway

SHOWN WITH  
TFT MASTER 1250 ER NOZZLE  
AND  
HURRICANE RC MONITOR

\*\* - OUTLETS SHOWN ARE  
FOR HURRICANE RC MODELS.  
FOR CROSSFIRE MODELS,  
SUBTRACT 1" 3/4

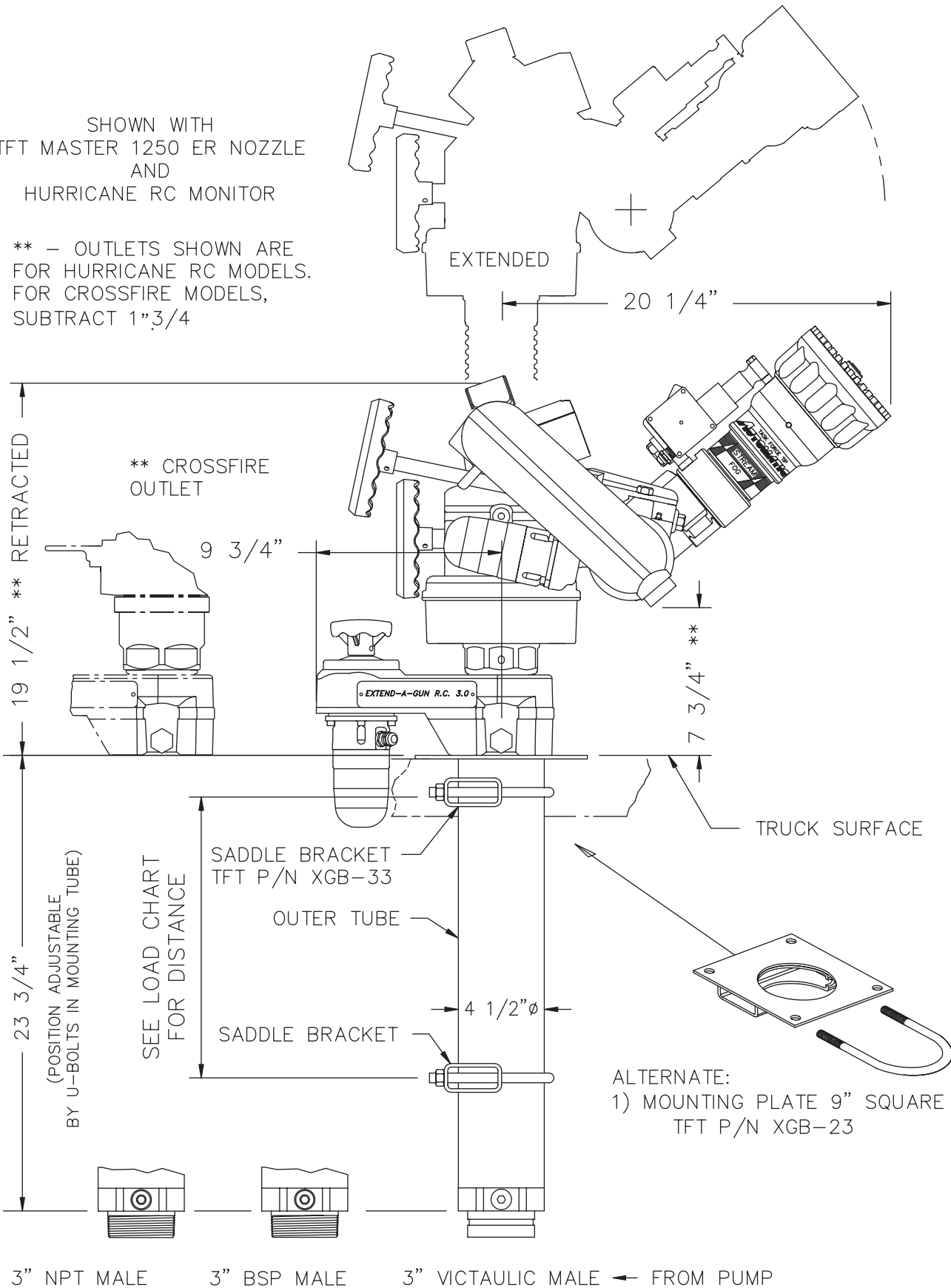

# 18" EXTEND-A-GUN RC4 4" Waterway

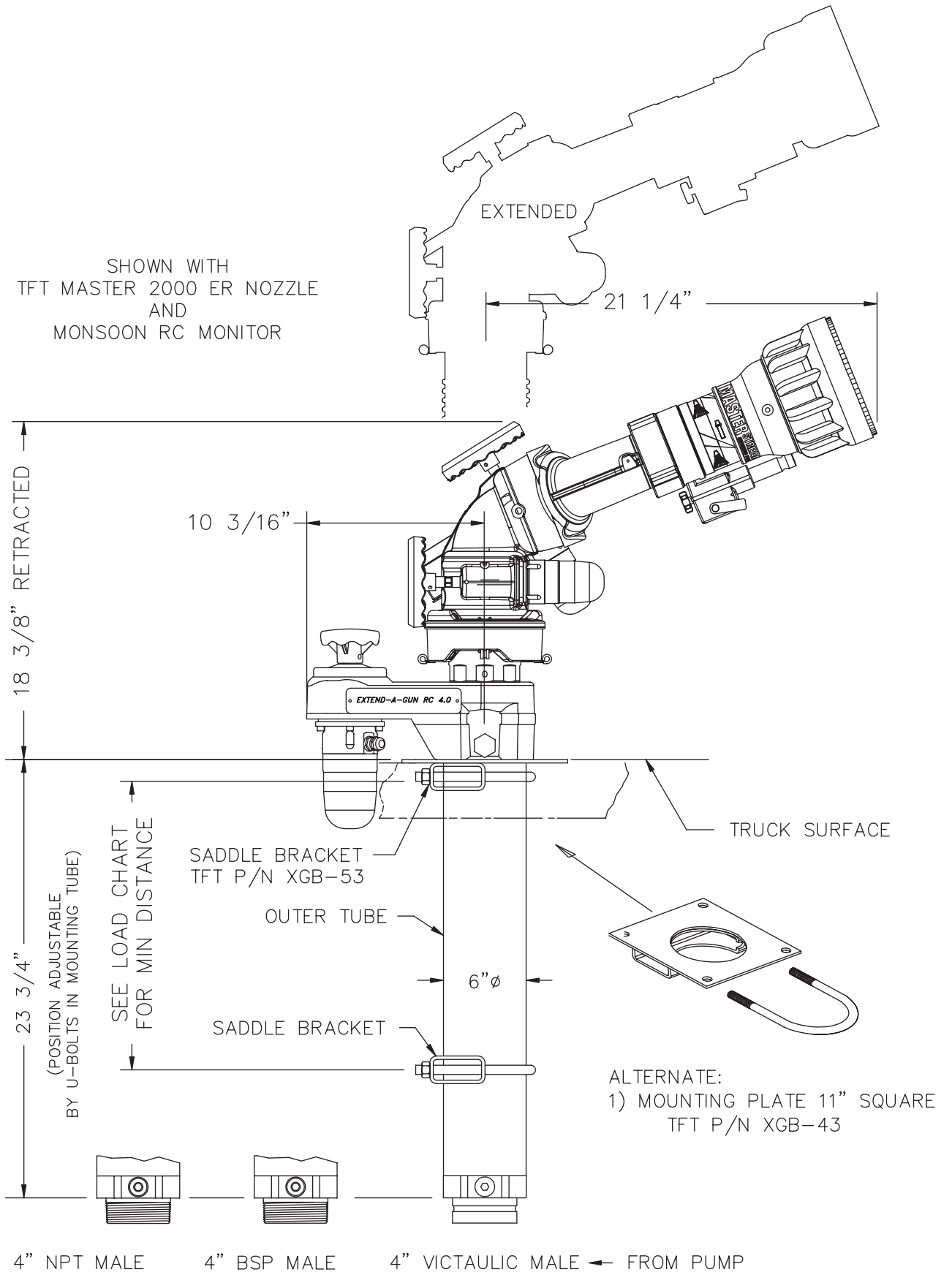

## 4.0 BRACKET SETS

For safe dependable service, the Extend-A-Gun RC **MUST** be securely mounted. To make the Extend-A-Gun RC as versatile as possible, three mounting bracket kits are offered. Each kit has a different upper bracket. The lower bracket is the same in all three.



**Task Force Tips strongly recommends that Extend-A-Gun RC be installed using the bracket sets, sold by Task Force Tips that are designed for this purpose. For the Extend-A-Gun RC to operate safely and properly, it must be installed in such a way that the brackets can withstand the forces resulting from the nozzle reaction force. The Task Force Tips bracket sets are designed to fit the Extend-A-Gun RC outer tube very closely to prevent distortion of the outer tube and to give it adequate support.**

### 4.1 SELECTION OF STRUCTURAL SUPPORT ON FIRE TRUCKS.

The forces acting on the mounting brackets, when the Extend-A-Gun RC is in the extended position, are higher than the forces in a normal deck gun installation. The loads on the brackets created from nozzle reaction can exceed 3000 lbs when the Extend-A-Gun is fully extended. These loads are transferred directly to the mounting brackets and the structural members they are attached to. It is crucial that the structural members selected, can withstand these forces. Qualified persons should calculate these forces and determine suitable mounting locations and structural members. Failure to properly secure the Extend-A-Gun RC, could result in damaged equipment and serious injury.



**Reaction forces generated by master stream flows are very powerful and capable of causing injury and property damage. The Extend-A-Gun RC must be securely mounted to rigid truck support members. Qualified persons should determine suitable mounting locations.**



**Inferior welding or poor plate installation could result in serious injury or equipment damage. Qualified individuals should conduct mounting bracket installation.**

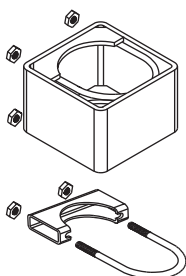

TUBE/SADDLE BRACKET SET  
**XGB-13** (Extend-A-Gun RC3)  
**N/A** (Extend-A-Gun RC4)

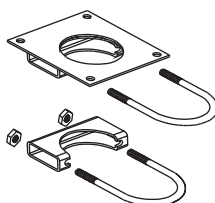

PLATE/SADDLE BRACKET SET  
**XGB-23** (Extend-A-Gun RC3)  
**XGB-43** (Extend-A-Gun RC4)

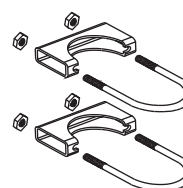

SADDLE/SADDLE BRACKET SET  
**XGB-33** (Extend-A-Gun RC3)  
**XGB-53** (Extend-A-Gun RC4)

### 4.2 TUBE BRACKET INSTALLATION (Extend-A-Gun RC3 Only)

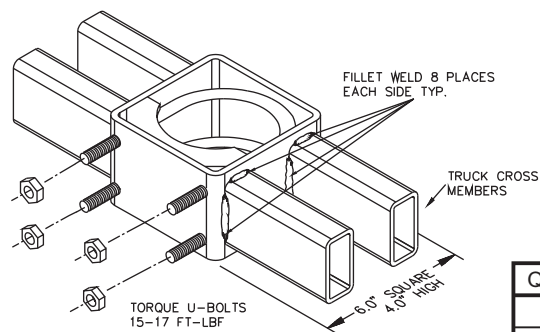

QTY	PART	DESCRIPTION
4	VT37-16FNT	3/8-16 FLANGED HEX NUT
1	XG480	TUBE BRACKET
2	XG475	4-1/2 U-BOLT 3/8 DIA.

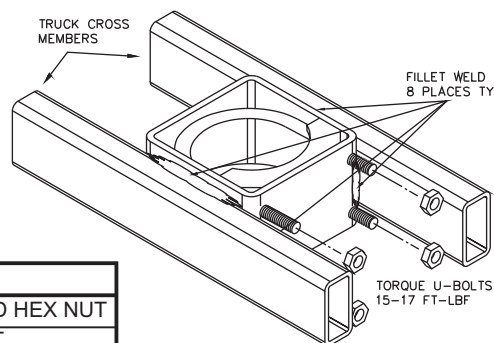

### TUBE BRACKET WELDING

This kit contains a six inch square steel tube with two U-bolts to be used as the upper bracket and a saddle bracket, similar to a heavy duty muffler clamp for the lower bracket. Both brackets must be used. This kit is designed primarily for installation in trucks as they are being built at the factory. The tube bracket may be welded onto the truck tubular framework, as shown on the Tube Bracket Welding Diagram. The lower bracket, as shown in the Saddle Bracket Welding Diagrams, should be welded to an additional support and clamped as low as possible on the bottom of the Extend-A-Gun RC tube. Make sure the welds are capable of withstanding the forces shown on the Side Loads At Mounting Points Diagram. The Extend-A-Gun RC may be installed in the brackets after the truck is painted. Use Loctite, supplied in kit on U-bolt threads, and torque nuts on upper U-bolts to 15-17 ft-lbf, torque nuts on lower U-bolts to 36-40 ft-lbf.



### 4.3 SADDLE BRACKET INSTALLATION

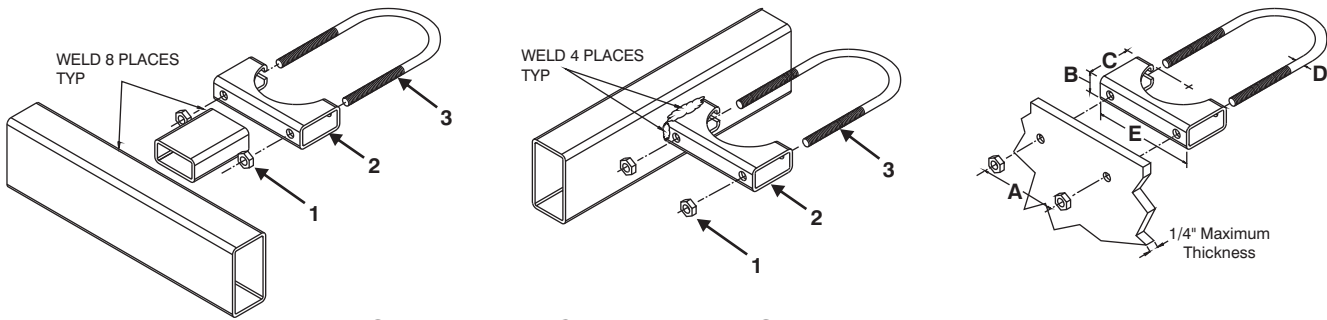

#### SADDLE BRACKET WELDING

This kit contains two steel saddle brackets and U-bolts, and is designed for factory installation on new equipment. Both Brackets must be used and must be welded to truck framework as far apart as possible yet still clamp on the Extend-A-Gun RC tube. The welds must be able to withstand the forces shown on the Side Loads at Mounting Points Diagram (page 8). The Extend-A-Gun RC may be installed in the brackets after the truck is painted. Use Loctite, supplied in kit on U-bolts.

### 4.4 PLATE BRACKET INSTALLATION

This kit may be used in either new or retro-fit installations. The top plate with its bracket may be bolted above or below an existing deck. The lower saddle bracket is installed as previously shown. Both brackets must be used. To minimize the stress on the brackets they should be as far apart as possible when clamped to the Extend-A-Gun RC tube. Please refer to the Side Loads at Mounting Points Diagram and make sure the mounting points can withstand these forces. Use Loctite®, supplied in kit on all threads, torque bolts.

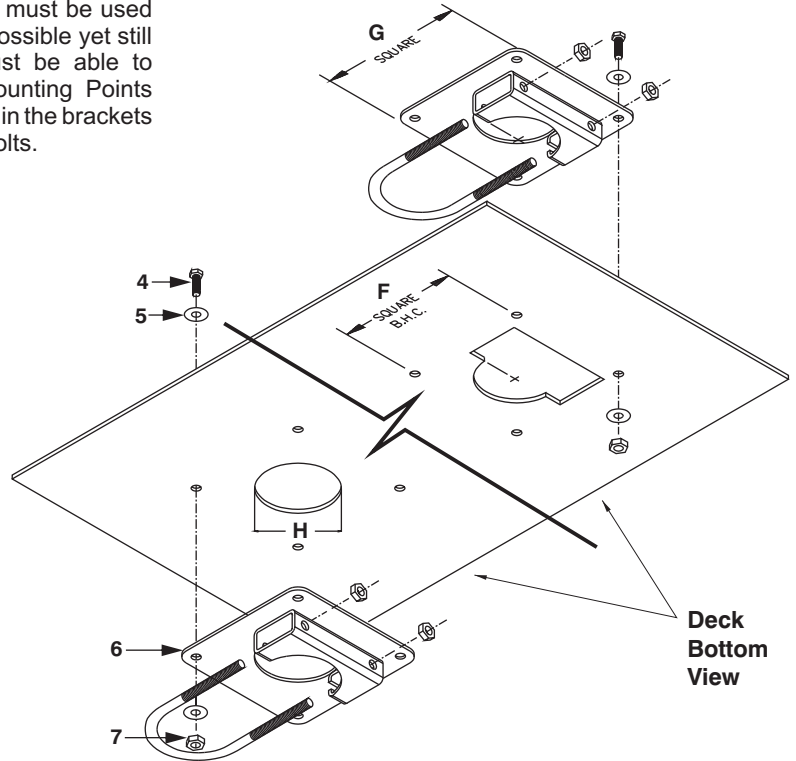

MODEL	EXTEND-A-GUN RC3		EXTEND-A-GUN RC4	
TORQUE U-BOLTS	30-40 ft-lbs	(49-54 nm)	70-80 ft-lbs	(95-108 nm)
A = Center Distance	5.0"	(127mm)	6.54"	(166mm)
B = Height	1.5"	(38mm)	2.0"	(51mm)
C = Width	3.0"	(76mm)	4.0"	(102mm)
D = U-Bolt Size	1/2-13 UNC		5/8-11 UNC	
E = Length	6.0"	(152mm)	9.0"	(228mm)
F = Square Pattern on Plate	7.5"	(191mm)	9.5"	(241mm)
G = Plate Width & Length	9" x 9" (288mm x 288mm)		11" x 11" (279mm x 279mm)	
H = Hole Diameter	4-5/8"	(117mm)	6-1/4"	(159mm)
1 = Hex Nut (2 rqd)	VT50-13NT		VT62-11NT	
2 = Saddle Bracket	XG486		XG488	
3 = U-Bolt	XG476		XG477	
4 = Deck Bolt	1/2-13 Hex Bolt		1/2-13 Hex Bolt	
5 = Washer	1/2" I.D.		1/2" I.D.	
6 = Plate Bracket	XG485		XG487	
7 = Deck Nut	1/2-13 Hex Bolt		1/2-13 Hex Bolt	

5.0 SIDE LOADS AT MOUNTING POINTS

5.1 12" EXTEND-A-GUN RC3

# 12" EXTEND-A-GUN RC3



Before installing the Extend-A-Gun RC you **MUST** determine the forces that will be exerted in the proposed installation by the reaction force of the nozzle.

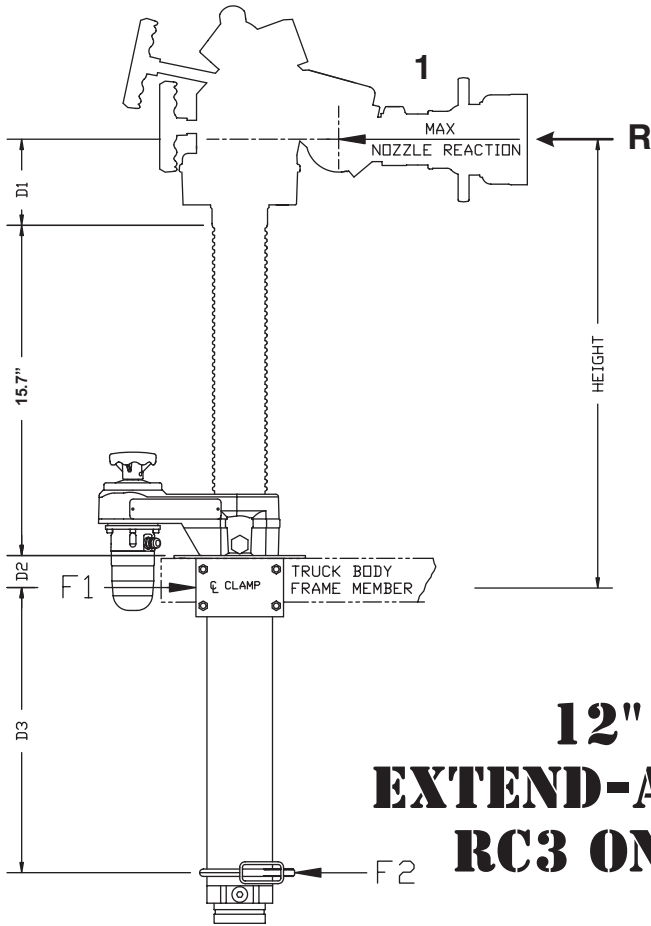

1) Determine the distance, D1, in inches, from the center of the monitor elevation joint to the bottom of the threads in the monitor inlet.

D1 FOR MOST COMMON INSTALLATIONS	
Task Force Tips CROSSFIRE	D1 = 2"
Task Force Tips HURRICANE	D1 = 6"
Task Force Tips MONSOON	D1 = 13"
Task Force Tips TORNADO	D1 = 13"
Task Force Tips TYPHOON	D1 = 19"

D1 =  inches

2) Locate the value of D1, in the charts on page 9. Find the desired HEIGHT from the center of the upper bracket to the center of the stream.

3) Locate D2, the distance from the bottom of the latch casting to the center of the upper mounting bracket, for the chosen HEIGHT. (inches)

D2 =  inches

## 12" EXTEND-A-GUN RC3 ONLY

4) Determine the distance, D3 in inches, from the center of the upper mounting bracket to the center of the lower mounting bracket for the proposed installation. **D3 MUST be between D3 min and D3 max.**

D3 =  inches

5) Calculate forces on Brackets, Add D1 + D2 + D3 + 15.7 =

D1  + D2  + D3  + 15.7 = L  inches

6) Determine R maximum nozzle reaction from load charts on page 11.

R =  pounds

7) Multiply L x R

L  x R  = M  inch • pounds

8) Divide M by D3

M  / D3  = F1  pounds

9) Subtract R from F1

F1  - R  = F2  pounds

# 12" EXTEND-A-GUN RC3

## 3" Waterway

### R = Maximum Nozzle Reaction 900 lbf

**NOTE:** F1 **MUST** be less than 3100 lbf. F2 **MUST** be less than 2200 lbf.  
And the proposed installation **MUST** be capable of withstanding forces of this magnitude.



**WARNING** Injury can result from an inadequately supported monitor. The monitor mount must be capable of supporting the nozzle reaction force which can be as high as 900 lbf. (400 kg). Flanges and pipe made from plastic are inadequate for monitor mounting and must not be used.

D1	D2	HEIGHT	D3 min	D3 max
1	1	18	7	14
	2	19	8	13
	3	20	8	12
	4	21	8	11
	5	22	9	10
	6	23	9	9

D1	D2	HEIGHT	D3 min	D3 max
4	1	21	8	14
	2	22	9	13
	3	23	9	12
	4	24	10	11
	5	25	10	10

D1	D2	HEIGHT	D3 min	D3 max
7	1	24	10	14
	2	25	10	13
	3	26	11	12
	4	27	11	11

D1	D2	HEIGHT	D3 min	D3 max
2	1	19	8	14
	2	20	8	13
	3	21	8	12
	4	22	9	11
	5	23	9	10

D1	D2	HEIGHT	D3 min	D3 max
5	1	22	9	14
	2	23	9	13
	3	24	10	12
	4	25	10	11

D1	D2	HEIGHT	D3 min	D3 max
8	1	25	10	14
	2	26	11	13
	3	27	11	12
	4	28	11	11

D1	D2	HEIGHT	D3 min	D3 max
3	1	20	8	14
	2	21	8	13
	3	22	9	12
	4	23	9	11
	5	24	10	10

D1	D2	HEIGHT	D3 min	D3 max
6	1	23	9	14
	2	24	10	13
	3	25	10	12
	4	26	11	11

D1	D2	HEIGHT	D3 min	D3 max
9	1	26	11	14
	2	27	11	13
	3	28	11	12

D1	D2	HEIGHT	D3 min	D3 max
10	1	27	11	14
	2	28	11	13
	3	29	12	12

**CHART FOR MODEL  
XGA32 SERIES ONLY**

**LOAD CHARTS FOR 12" EXTEND-A-GUN RC3 ONLY**

5.2 18" EXTEND-A-GUN RC3 & RC4

# 18" EXTEND-A-GUN



Before installing the Extend-A-Gun RC you **MUST** determine the forces that will be exerted in the proposed installation by the reaction force of the nozzle.

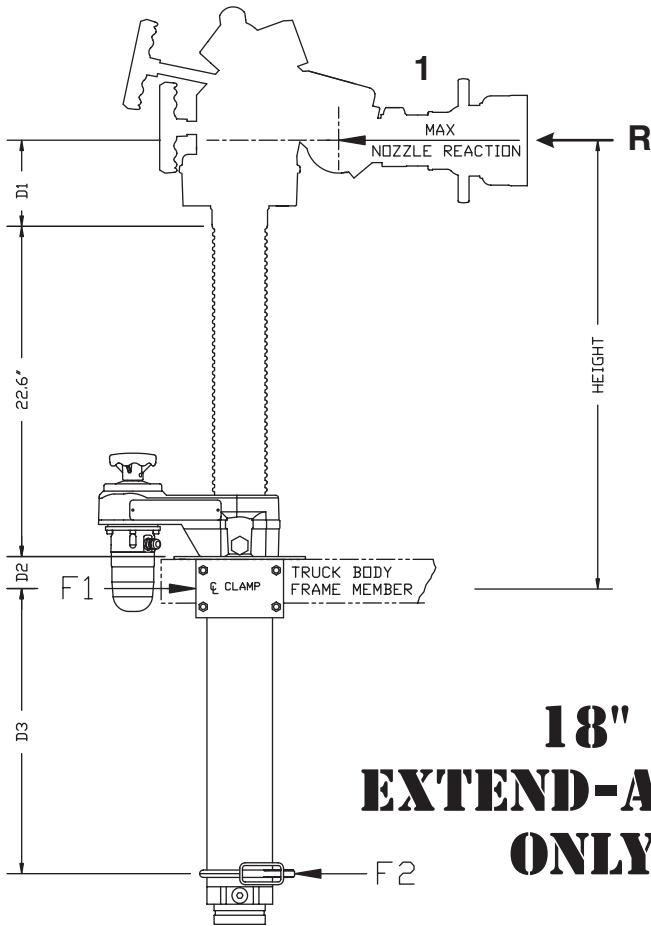

1) Determine the distance, D1, in inches, from the center of the monitor elevation joint to the bottom of the threads in the monitor inlet.

D1 FOR MOST COMMON INSTALLATIONS		
Task Force Tips CROSSFIRE	D1 = 2"	
Task Force Tips HURRICANE	D1 = 6"	
Task Force Tips MONSOON	D1 = 13"	
Task Force Tips TORNADO	D1 = 13"	
Task Force Tips TYPHOON	D1 = 19"	

D1 =  inches

2) Locate the value of D1, in the charts on page 9. Find the desired HEIGHT from the center of the upper bracket to the center of the stream.

3) Locate D2, the distance from the bottom of the latch casting to the center of the upper mounting bracket, for the chosen HEIGHT. (inches)

D2 =  inches

## 18" EXTEND-A-GUN ONLY

4) Determine the distance, D3 in inches, from the center of the upper mounting bracket to the center of the lower mounting bracket for the proposed installation. **D3 MUST be between D3 min and D3 max.**

D3 =  inches

5) Calculate forces on Brackets, Add D1 + D2 + D3 + 22.6 =

D1  + D2  + D3  + 22.6 = L  inches

6) Determine R maximum nozzle reaction from load charts on pages 13 and 14.

R =  pounds

7) Multiply L x R

L  x R  = M  inch • pounds

8) Divide M by D3

M  / D3  = F1  pounds

9) Subtract R from F1

F1  - R  = F2  pounds

# 18" EXTEND-A-GUN RC3

## 3" Waterway

**R = Maximum Nozzle Reaction 900 lbf**

**NOTE:** F1 **MUST** be less than 3100 lbf. F2 **MUST** be less than 2200 lbf.  
And the proposed installation **MUST** be capable of withstanding forces of this magnitude.



Injury can result from an inadequately supported monitor. The monitor mount must be capable of supporting the nozzle reaction force which can be as high as 900 lbf. (400 kg). Flanges and pipe made from plastic are inadequate for monitor mounting and must not be used.

D1	D2	HEIGHT	D3 min	D3 max
1	1	25	11	20
	2	26	11	19
	3	27	11	18
	4	28	12	17
	5	29	12	16
	6	30	13	15
	7	31	13	14
	8	32	13	13

D1	D2	HEIGHT	D3 min	D3 max
5	1	29	12	20
	2	30	13	19
	3	31	13	18
	4	32	13	17
	5	33	14	16
	6	34	14	15

D1	D2	HEIGHT	D3 min	D3 max
9	1	33	14	20
	2	34	14	19
	3	35	15	18
	4	36	15	17
	5	37	15	16

D1	D2	HEIGHT	D3 min	D3 max
2	1	26	11	20
	2	27	11	19
	3	28	12	18
	4	29	12	17
	5	30	13	16
	6	31	13	15
	7	32	13	14

D1	D2	HEIGHT	D3 min	D3 max
6	1	30	13	20
	2	31	13	19
	3	32	13	18
	4	33	14	17
	5	34	14	16
	6	35	15	15

D1	D2	HEIGHT	D3 min	D3 max
10	1	34	14	20
	2	35	15	19
	3	36	15	18
	4	37	15	17
	5	38	16	16

D1	D2	HEIGHT	D3 min	D3 max
3	1	27	11	20
	2	28	12	19
	3	29	13	18
	4	30	13	17
	5	31	13	16
	6	32	14	15
	7	33	14	14

D1	D2	HEIGHT	D3 min	D3 max
7	1	31	13	20
	2	32	13	19
	3	33	14	18
	4	34	14	17
	5	35	15	16
	6	36	15	15

D1	D2	HEIGHT	D3 min	D3 max
11	1	34	15	20
	2	35	15	19
	3	36	15	18
	4	37	16	17
	5	38	16	16

D1	D2	HEIGHT	D3 min	D3 max
4	1	28	12	20
	2	29	12	19
	3	30	13	18
	4	31	13	17
	5	32	13	16
	6	33	14	15
	7	34	14	14

D1	D2	HEIGHT	D3 min	D3 max
8	1	32	13	20
	2	33	14	19
	3	34	14	18
	4	35	15	17
	5	36	15	16
	6	37	15	15

D1	D2	HEIGHT	D3 min	D3 max
12	1	34	15	20
	2	35	15	19
	3	36	16	18
	4	37	17	17

D1	D2	HEIGHT	D3 min	D3 max
13	1	34	15	20
	2	35	16	19
	3	36	16	18
	4	37	17	17

**LOAD CHARTS FOR 18" EXTEND-A-GUN RC3 ONLY**

# 18" EXTEND-A-GUN RC4

## 4" Waterway

**R = Maximum Nozzle Reaction 1500 lbf**

**NOTE:** F1 **MUST** be less than 5000 lbf. F2 **MUST** be less than 3500 lbf.  
And the proposed installation **MUST** be capable of withstanding forces of this magnitude.



**Injury can result from an inadequately supported monitor. The monitor mount must be capable of supporting the nozzle reaction force which can be as high as 1500 lbf. (680 kg). Flanges and pipe made from plastic are inadequate for monitor mounting and must not be used.**

D1	D2	HEIGHT	D3 min	D3 max
1	1	25	11	20
	2	26	12	19
	3	27	12	18
	4	28	12	17
	5	29	13	16
	6	30	13	15
	7	31	14	14

D1	D2	HEIGHT	D3 min	D3 max
5	1	29	13	20
	2	30	13	19
	3	31	14	18
	4	32	14	17
	5	33	15	16
	6	34	15	15

D1	D2	HEIGHT	D3 min	D3 max
9	1	33	15	20
	2	34	15	19
	3	35	15	18
	4	36	16	17
	5	37	16	16

D1	D2	HEIGHT	D3 min	D3 max
2	1	26	12	20
	2	27	12	19
	3	28	12	18
	4	29	13	17
	5	30	13	16
	6	31	14	15
	7	32	14	14

D1	D2	HEIGHT	D3 min	D3 max
6	1	30	13	20
	2	31	14	19
	3	32	14	18
	4	33	15	17
	5	34	15	16
	6	35	15	15

D1	D2	HEIGHT	D3 min	D3 max
10	1	34	15	20
	2	35	15	19
	3	36	16	18
	4	37	16	17

D1	D2	HEIGHT	D3 min	D3 max
11	1	35	15	20
	2	36	16	19
	3	37	16	18
	4	38	17	17

D1	D2	HEIGHT	D3 min	D3 max
3	1	27	12	20
	2	28	12	19
	3	29	13	18
	4	30	13	17
	5	31	14	16
	6	32	14	15

D1	D2	HEIGHT	D3 min	D3 max
7	1	31	14	20
	2	32	14	19
	3	33	15	18
	4	34	15	17
	5	35	15	16

D1	D2	HEIGHT	D3 min	D3 max
12	1	36	16	20
	2	37	16	19
	3	38	17	18
	4	39	17	17

D1	D2	HEIGHT	D3 min	D3 max
4	1	27	12	20
	2	28	12	19
	3	29	13	18
	4	30	13	17
	5	31	14	16
	6	32	14	15

D1	D2	HEIGHT	D3 min	D3 max
8	1	32	14	20
	2	33	15	19
	3	34	15	18
	4	35	15	17
	5	36	16	16

D1	D2	HEIGHT	D3 min	D3 max
13	1	37	16	20
	2	38	17	19
	3	39	17	18

**LOAD CHARTS FOR 18" EXTEND-A-GUN RC4 ONLY**

## 6.0 MANUAL OVERRIDE

Each Extend-A-Gun RC is equipped with an override knob. In the event of power loss, turn the knob clockwise to raise the tube or counterclockwise to lower it.

### 6.1 REPOSITIONING OVERRIDE KNOB

The override knob can be positioned on the top (fig. a) or bottom (fig. b) of the mechanism if desired.

- 1) Remove the 1/4" cap screws from the override cap and motor housing.
- 2) Remove the electric motor and override knob assembly.
- 3) Reinstall the motor in desired position.
- 4) Reinstall override knob assembly.
- 5) Reinstall 1/4" cap screws.

The motor polarity may be reversed by simultaneously depressing both up and down buttons for 15 seconds.

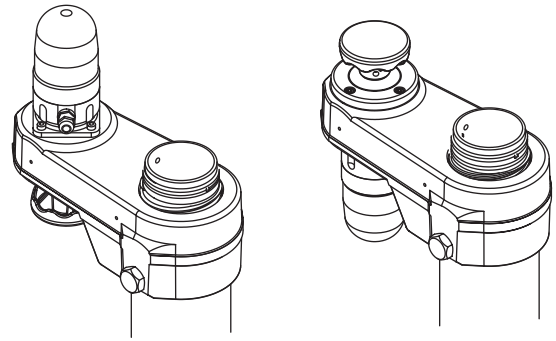

Fig. a

Fig. b

## 7.0 CONTROL BOX INSTALLATION

The Extend-A-Gun RC assembly contains a control box, which houses the electronics that control the electric motor, and a panel mount operator station. The panel mount operator station installation is optional and not required if using RC monitor operator stations for control. Most of the wiring has been factory installed so the installation of this control box will include mounting the control box and connecting the wires. A 14-gauge power & communications cable, 10 ft (3m) long, is supplied for connection to the power source and RC monitor communication link. A 14-gauge cable, 10 ft (3m) long, is provided for connection to the RC Extend-A-Gun motor. A 14-gauge cable, 12 ft (3.6m) long, is provided for connection to the RC monitor mounted on top of the RC Extend-A-Gun. If longer length is needed, consult factory. The RC Extend-A-Gun is designed to operate on 12V DC. **Operation on 24VDC requires a 24VDC to 12VDC converter.** The RC Extend-A-Gun control box and motor are not rated as ignition proof, explosion proof, or intrinsically safe.



**WARNING**

The electric motor and other components are ignition sources. The electric Extend-A-Gun RC should be operated only in areas where there is adequate ventilation and no hazard of flammable vapor buildup.



**CAUTION**

An inadequate power supply will not drive the electric motor causing a failure to extend the telescoping waterway which will limit the operating range of the monitor. This will result in an increased risk of injury because the effectiveness of the monitor is reduced. Avoid use of thin conductors or long cable. Check installation to insure that a minimum voltage of 10 VDC is present when motor is running.

### 7.1 CONTROL BOX MOUNTING

Select proper operator location. Enclosure is designed to be surface mounted and the size is 5 3/4" x 8 3/4" (146 x 222mm). Height of enclosure is 2 1/4" (57mm). Refer to Figure 7.1 for mounting hole dimensions.

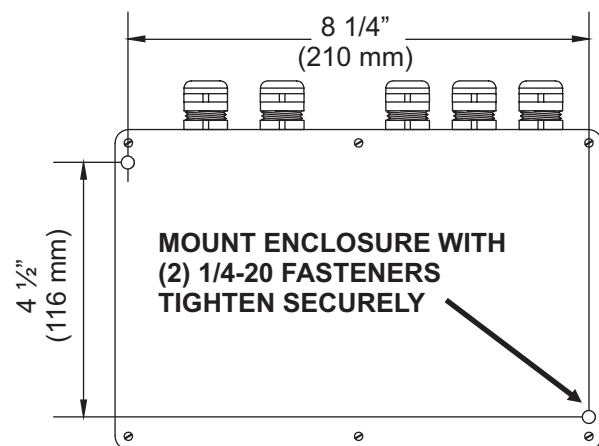
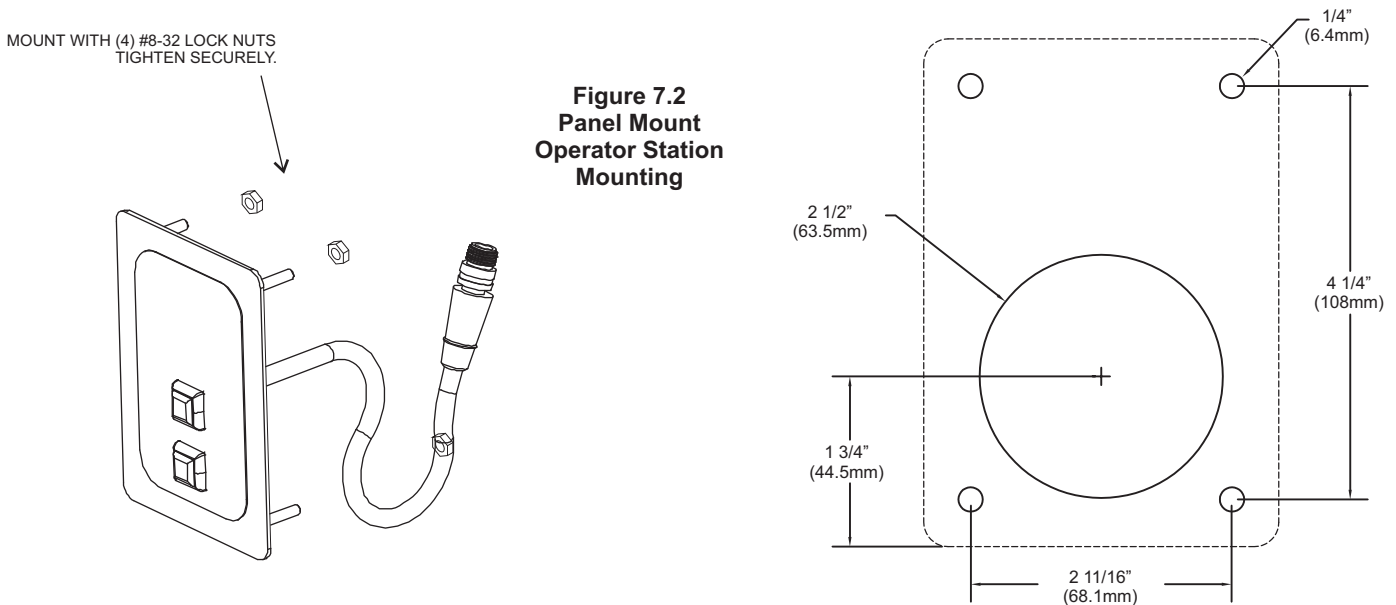

Fig 7.1

Electrical Enclosure Mounting Hole Dimensions

## 7.2 PANEL MOUNT OPERATOR STATION MOUNTING (OPTIONAL)

Select proper operator location. Operator should be available to view RC Extend-A-Gun operation while operating up/down buttons. Panel space required will be 5-1/4" x 3-5/8" (130mm x 90mm). A depth of 3" (75mm) will be required behind the panel. Refer to Figure 7.2 for dimensions. **Be sure to install supplied cable clamp to relieve strain on pushbutton wires.**



**Figure 7.2**  
Panel Mount  
Operator Station  
Mounting

## 7.3 CONTROL BOX WIRING

The power supply for the RC Extend-A-Gun will need to be connected to a protected circuit from the trucks power distribution center. The waterproof control box is factory sealed. The box should not be opened unless service to the circuit board is needed.

- Good mechanical connections on the wires are absolutely necessary and should be checked periodically.
- Poor electrical connections can cause power loss to the RC Extend-A-Gun and a fire hazard.
- Be careful to route cables in a protected area away from high heat sources.
- Use grommets whenever wires pass through holes to prevent damage due to snags, abrasions, etc.
- Secure cables close to control box with plastic wire tie or cable clamp to relieve stress on the cables.
- Disconnect power before installing or servicing the electrical components.
- Careful selection of wiring is critical to avoid excessive voltage drop.

After mounting control box RC Extend-A-Gun, and RC monitor refer to Figure 7.3 for wiring connections.

Refer to RC monitor manuals (LIY-200, LIY-300, LIX-300 or LIY-050) section 5 for connecting to communication link.

**Figure 7.3**  
Control Box Wiring

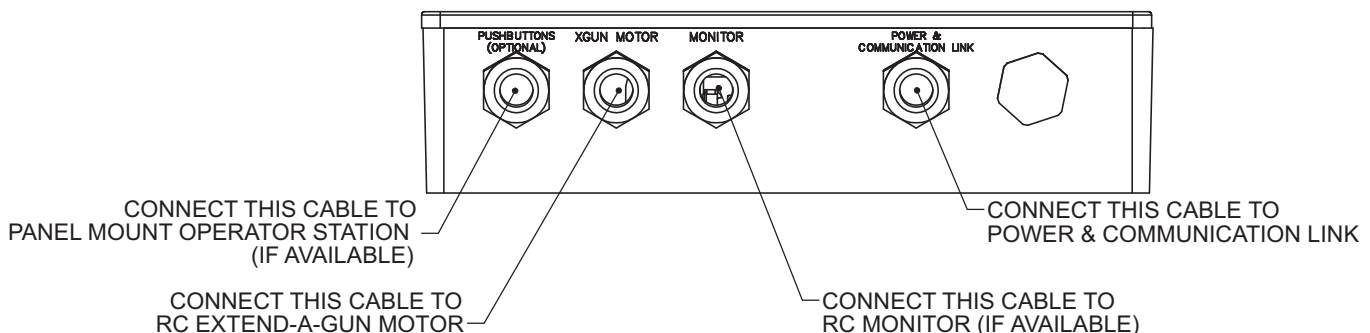



## 7.4 ELECTRICAL TESTING

### 7.4.1 VERIFY PROPER VOLTAGE

The TFT Extend-A-Gun has built in circuit protection to guard against a circumstance where the unit's movement is blocked before reaching its full travel limits. Without this circuitry the motor would stall, overheat, and could be permanently damaged.

This circuit works by detecting the increase in electrical current that occurs when the motor stops turning at the end stops or if the travel is blocked by an obstruction. To test this function, run the unit against an end stop using a button on the control pad. Continue to hold the button after the Extend-A-Gun has reached the end stop, and then turn the manual override to make sure that the motor has been disengaged from the circuit. If the motor cannot be turned by hand, this indicates that the motor has not been disengaged from the circuit and electrical power is still applied. If this occurs, the most likely cause is the voltage supplied to the Extend-A-Gun is too low.

To ensure proper voltage to the Extend-A-Gun, the wiring needs to be checked for proper gauge for the installed length of wire, and for proper termination. Also, ensure that the power source supplying the Extend-A-Gun and the grounding is adequate (other electrical loads on a shared circuit with the Extend-A-Gun may cause a low-voltage situation).

In addition to motor damage, a further consequence of low voltage could be that the unit will not extend and retract properly or fully.

### 7.4.2 SET TRAVEL STOPS

When electrical connections are complete, perform the following to set the full travel and to verify voltage supply is adequate and the current limiting feature is functioning.

- 1) Apply power to RC Extend-A-Gun control box.
- 2) Press DOWN button or AUX1 button and continue to hold until RC Extend-A-Gun is fully retracted. Motor must stop by current limit method. If motor continues to operate see note below.
- 3) Press UP button or AUX1 button and continue to hold until RC Extend-A-Gun is fully extended.
- 4) Once movement is stopped, manually turn override knob in opposite direction. If knob can be turned, then voltage supply is adequate. See note below.

**NOTE: If knob cannot be turned and motor continues to operate, then the voltage supply or wiring is not adequate. Check connections and voltage connection point, rewire if necessary. Override knob will only turn in one direction.**

**ANY TIME THE MANUAL OVERRIDE KNOB IS USED, OPERATOR MUST PERFORM STEPS 2 & 3 ABOVE TO RESET THE FULL TRAVEL LIMITS.**

## 7.5 AUX1 BUTTON OVERLAY

Each RC Extend-A-Gun is shipped with several button overlays with adhesive that can be attached to any RC monitor operator station with an AUX1 button. If additional overlays are needed, contact factory.

Clean operator station surface to remove any oils or residues. Carefully peel off overlay and place on top of AUX1 button, just inside blue border of button.

Figure 7.4  
Aux 1 Button Overlay

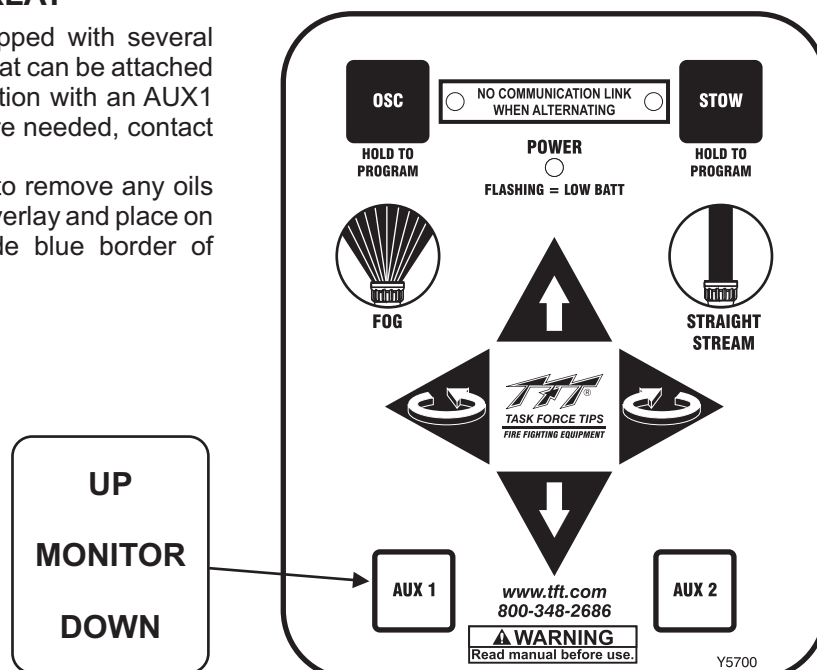

## 8.0 INDICATOR SWITCH WIRING

The Extend-A-Gun RC contains a magnetic switch. This switch is intended to be used with a MONITOR EXTENDED warning light. The magnetic switch in the Extend-A-Gun RC is a normally open switch, and the switch is closed when the Extend-A-Gun RC is in the down position. The enclosed relay **MUST BE USED** to limit the current through the switch.

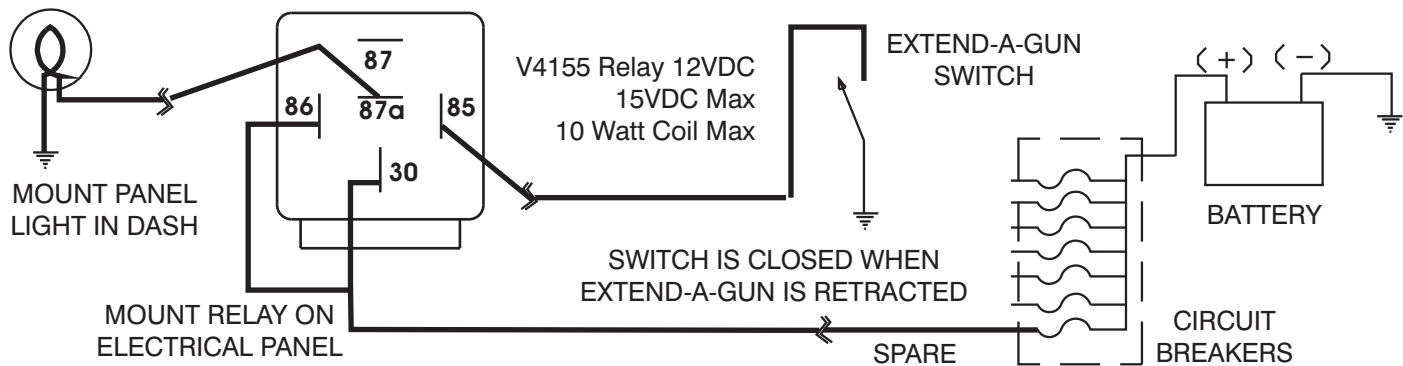

- 1) Mount the relay on the electrical panel with the terminals accessible.
- 2) Drill a 1/2" diameter hole in the dashboard for the panel light. Leave enough room for a 1-13/16" diameter label around the light or a 2" wide x 1-1/2" high label next to the light. Apply one of the two warning labels and push the panel light through the hole in the dash.
- 3) Connect the labeled wires on the switch to terminal #85 on the relay and ground respectively.
- 4) Connect the terminals on the panel light to terminal #87A on the relay and ground respectively.
- 5) Connect a wire from a "spare" position on the trucks circuit breaker panel to terminals #30 and #86. The circuit from the "spare" position in the fuse block should only be energized when the ignition switch is in the ON position.

## 9.0 LABELS

Attach the warning label (XGL020) next to the indicator light or warning label (XGL025) around the indicator light on the truck dashboard.



## 10.0 MOUNTING MONITOR

### 10.1 HURRICANE, MONSOON, TORNADO, AND TYPHOON

A Task Force Tips Hurricane, Monsoon®, Tornado, and Typhoon monitor(s) may be mounted directly on the Extend-A-Gun RC. The monitors are attached to the Extend-A-Gun RC by means of a threaded joint with an o-ring seal. Once in the proper orientation, the threaded joint is locked from rotation by two 1/4-28 button head cap screws. This makes for easy removal of the monitor since the large threads of the joint are not tightened and do not have any thread locking compounds on them. The installation sequence is as follows:

- 1) Raise the Extend-A-Gun inner tube approximately 6" up from the retracted position.
  - A) Mount so that 180 degree apart threaded cross-holes will give desired direction relative to the "Straight Ahead Reference Mark" when the monitor is installed. See appropriate section in your monitor installation manual.

- 2) Screw monitor onto Extend-A-Gun RC until threaded joint bottoms out.
  - A) Do not use pipe dope or Loctite on the inlet base threads. These threads are sealed with an o-ring. The use of thread locking compounds will make removal difficult.
- 3) Unscrew monitor until a pair of 90 degree apart slots lines up with the 180 degree apart threaded cross-holes in the Extend-A-Gun RC.
  - A) Orient monitor so that the Straight Ahead Reference Mark is facing the desired direction.
  - B) Slots will line up with threaded cross-holes every 90 degrees of rotation.
  - C) Monitor may be unscrewed up to one full turn from the bottomed out position.
- 4) Install ¼-28 by ½ long button head cap screws and washers in the two threaded cross- holes. Use Loctite #271 on the threads of the button head cap screws. Allow Loctite to fully cure before applying water pressure.

## 10.2 CROSSFIRE ON EXTEND-A-GUN RC3

The Task Force Tips Crossfire®, can also be mounted on Extend-A-Gun RC3 using Task Force Tips part XFF-RLF Snout, which fits only the Task Force Tips Crossfire®. To attach the XFF-RLF Snout to the Extend-A-Gun RC3:

- 1) Raise the Extend-A-Gun inner tube approximately 6 " up from the retracted position. Place the guide ring over the inner tube.
- 2) Screw the Snout onto the Extend-A-Gun RC3 until the threaded joint bottoms out. **DO NOT USE PIPE DOPE OR LOCKTITE ON THE INLET THREADS.** The connection is sealed with an o-ring. Use of thread locking compounds will make removal difficult.
- 3) Unscrew snout until slotted holes in the Snout line up with the tapped holes in the Extend-A-Gun RC3. (The Snout may be unscrewed up to one full turn from the bottomed out position)
- 4) Install ¼-28 x ½" long button head cap screws and stainless washers into the threaded holes. Use Locktite on the threads of the screws.



**WARNING** Injury can occur from an inadequately supported monitor. The mounting must be capable of supporting the nozzle reaction force which can be as high as 1500 lbs.

## 11.0 USE OF DRAIN

The Extend-A-Gun RC comes with a ¾" NPT hole in every inlet. This is designed to be used as a drain or plugged and use a drain elsewhere. A drain must be employed to remove excess water from the system. This prevents freezing and allows the Extend-A-Gun RC to be park/stowed.



**WARNING** Injury can occur from an inadequately supported monitor. The mounting must be capable of supporting the nozzle reaction force which can be as high as 900 lbs.

## 12.0 OPERATING INSTRUCTIONS



**WARNING** Master stream flows are very powerful and capable of causing injury and property damage. Make sure the monitor is pointing in a safe direction before water to the monitor is turned on. Use care in directing the stream.



**CAUTION** Clear all obstructions away from the Extend-A-Gun RC before lowering. Anything caught underneath the monitor, could become crushed, when lowered.



**CAUTION** The drive train will extend and retract only when there is no water pressure. If the buttons are pushed while under water pressure, the current limiting will engage and not allow the Extend-A-Gun RC to move. This prevents damage to the unit.



**CAUTION** The Extend-A-Gun RC must be lowered in the park/stow position before the truck is driven or moved. Damage or injury may occur if the truck drives under a low hanging object, while the Extend-A-Gun RC is extended.

## **CAUTION**

The Extend-A-Gun RC may be used in either the raised or the lowered position, but not in-between. The seal may become damaged if the water is turned on in any position other than fully extended or retracted.

## **CAUTION**

Do not plug or cap the Extend-A-Gun RC or mounted deck gun while it is in the raised position. This will prevent the Extend-A-Gun RC from being lowered in the park/stow position. Damage may occur if the truck drives under a low hanging object, while the Extend-A-Gun RC is extended.

### **12.1 EXTEND**

- 1) Make certain the valve to the monitor is closed.
- 2) Press and release the “UP” button on any RC monitor operator station or the panel mount operator station to extend the mechanism. The tube will automatically extend fully, and then stop. Pressing the button while the RC Extend-A-Gun is in motion will cause the motor to switch directions. This system is controlled with current limiting. When the Extend-A-gun RC is being raised, the unit is provided with maximum allowable current to lift and still protect the mechanism from damage when an obstruction is encountered.
- 3) Position monitor to desired position.
- 4) Turn on water.

### **12.2 RETRACT**

## **CAUTION**

Clear all personnel and obstructions away from the Extend-A-Gun RC before lowering. The electric motor is capable of producing 100 lbs of crushing force in the down stroke. Anything caught underneath the monitor, could become crushed, when lowered.

- 1) Make certain the valve to the monitor is closed.
- 2) Return the monitor to its park/stow position.
- 3) On systems connected to the RC monitor communication link, at the completion of the PARK/STOW pattern, the RC Extend-A-Gun will automatically start to retract.
- 4) To manually retract, press and release the “DOWN” button on any RC monitor operator station or the panel mount operator station to retract the mechanism. The tube will automatically retract completely, and then stop. Pressing the button while the RC Extend-A-Gun is in motion will cause the motor to switch directions. This system is controlled with current limiting. When the RC Extend-A-Gun is being lowered, the current is reduced and the unit is slowed down. This provides a safer lowering of the unit and prevents a crushing injury in case someone is under the unit when it is lowered. *(Note: Tube will not retract from monitor operator station if monitor is not in PARK/STOW position.)*

### **12.3 MANUAL OVERRIDE**

Each Extend-A-Gun RC is equipped with an override knob. In the event of power loss, turn the knob clockwise to raise the tube or counterclockwise to lower it.

### **12.4 INDICATOR LIGHT**

The Extend-A-Gun RC has a built in switch to control an indicator light on the truck dashboard showing that the Extend-A-Gun RC is in the extended position. This is to help prevent damage that would occur if the deck gun hits a low overhanging object. Do not move the truck with the Extend-A-Gun RC in the extended position.

### **12.5 OPERATION BELOW FREEZING TEMPERATURES**

The apparatus that the Extend-A-Gun is mounted to may be stored in sub-freezing conditions. However, the Extend-A-Gun RC is not designed to operate in sub-freezing conditions. If in the rare instance that the Extend-A-Gun becomes inoperable due to a frozen condition, the manual override can be used to extend or retract the device.

### **12.6 CONTINUOUS OPERATIONS**

The Extend-A-Gun RC is designed to produce a short burst of maximum lifting power. This is provided by a combination of a powerful motor and a high torque gearbox. The motor/gearbox combination means that heat quickly builds up in the motor. As the heat increases, the efficiency decreases, thus reducing power and speed.

### **12.7 CURRENT LIMITING**

The Extend-A-Gun RC is designed to produce a short burst of maximum lifting power. The drive train is protected by a current limiting current. When the Extend-A-Gun RC is being raised, the unit is provided with maximum allowable current to lift and still protect the mechanism from damage when an obstruction is encountered. When the Extend-A-Gun RC is being lowered, the drive is programmed to run at a slower speed and the current limit is reduced. This provides a safer lowering of the unit and helps prevent a crushing injury in case someone is under the unit when it is lowered.

# 15.0 EXPLODED VIEW AND PARTS LIST

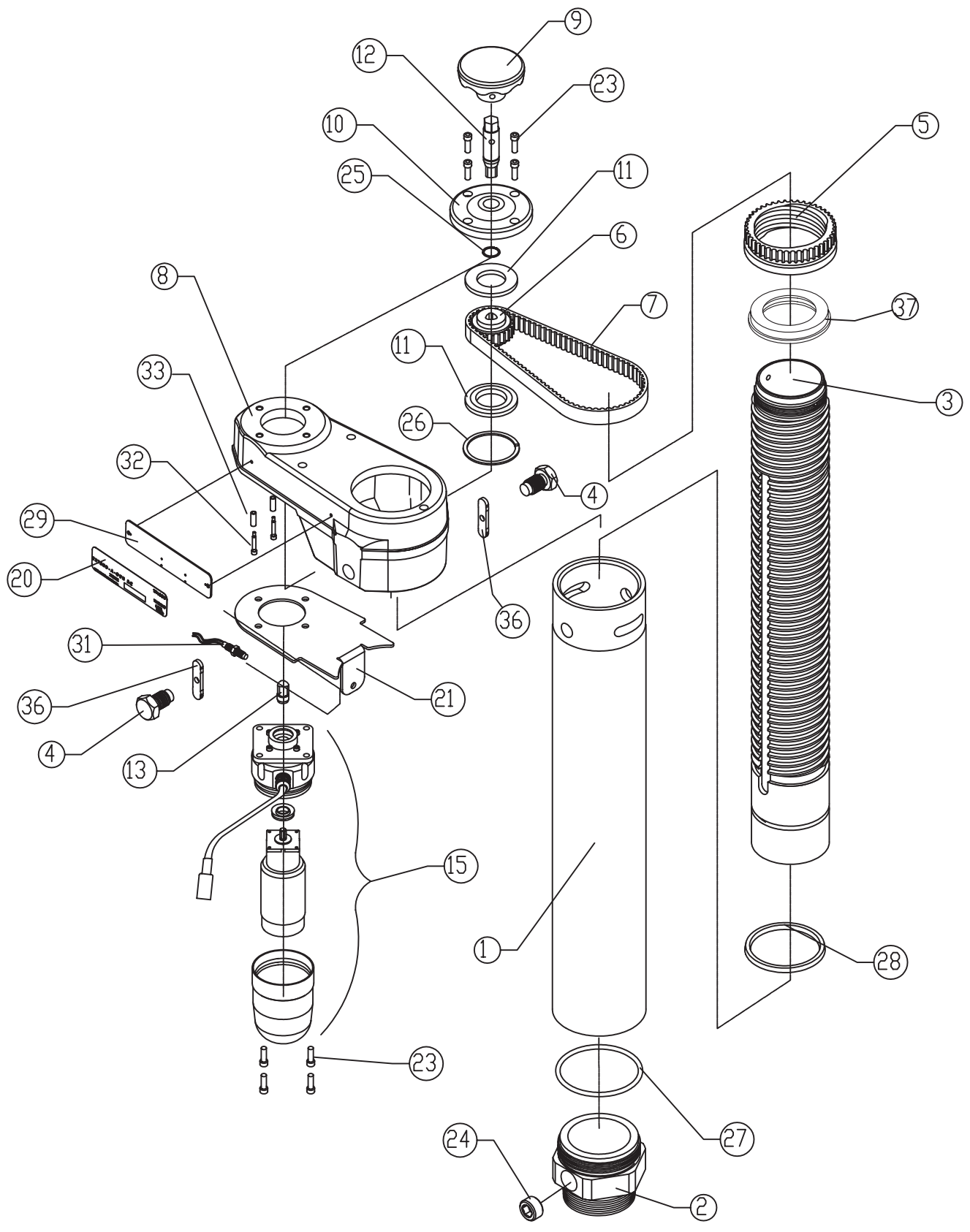

## EXTEND-A-GUN RC3

ITEM	DESCRIPTION	QTY	PART#
1	Outer Tube 12"	1	XG412
	Outer Tube 18"	1	XG418
2	3" NPT Male inlet	1	XG405PL
	3" BSP Male Inlet (not shown)	1	XG405BL
	3" Victaulic Male Inlet (not shown)	1	XG405VL
3	Inner Tube 12"	1	XGE312
	Inner Tube 18"	1	XGE318
4	Stop Bolt	2	XGE345
5	Ring Gear	1	XGE330
6	Drive gear	1	XGE335
7	Drive Belt	1	XGE350
8	Drive Box	1	XGE300
9	Override Knob	1	Y4165
10	Cap	1	XGE365
11	Keeper Bearing	2	XGE375
12	Override Shaft	1	XGE355
13	Motor Driveshaft	1	XGE370
15	Gear Motor Sub-Assembly	1	XGA950
20	Label	1	XGEL310
21	Guard	1	XGE360
22	Crossfire Inlet (not shown)	1	XGE390
23	1/4-20 x 3/4 SHCS	8	VT25-20SH75
24	3/4-14 NPT Pipe Plug	1	VFSP6M
25	Smalley Ring	1	VR4245
26	Smalley Ring	1	VR4280
27	O-Ring	1	VO-343
28	Cup Seal	1	XG125
29	Name Plate	1	XGEL320
31	Reed Switch	1	XGA840-KIT
32	Shoulder Bolts	2	VT25-00SB1.2
33	Roller	2	XGE320
36	Slider	2	XGE325
37	Seal	1	XGE333

## EXTEND-A-GUN RC4

ITEM	DESCRIPTION	QTY	PART#
1	Outer Tube	1	XGA428
2	4" NPT Male inlet	1	XGE505PP
	4" BSP Male Inlet (not shown)	1	XGE505BP
	4" Victaulic Male Inlet (not shown)	1	XGE505VP
3	Inner Tube	1	XGE418
4	Stop Bolt	2	XGE445
5	Ring Gear	1	XGE430
6	Drive gear	1	XGE435
7	Drive Belt	1	XGE450
8	Drive Box	1	XGE400
9	Override Knob	1	Y4165
10	Cap	1	XGE365
11	Keeper Bearing	2	XGE375
12	Override Shaft	1	XGE355
13	Motor Driveshaft	1	XGE370
15	Gear Motor Sub-Assembly	1	XGA950
20	Label	1	XGEL410
21	Guard	1	XGE460
23	1/4-20 x 3/4 SHCS	8	VT25-20SH75
24	3/4-14 NPT Pipe Plug	1	VFSP6M
25	Smalley Ring	1	VR4245
26	Smalley Ring	1	VR4280
27	O-Ring	1	VO-351
28	Cup Seal	1	XGE380
29	Name Plate	1	XGEL320
31	Reed Switch	1	XGA841-KIT
32	Shoulder Bolts	2	VT25-00SB1.2
33	Roller	2	XGE320
36	Slider	2	XGE325
37	Seal	1	XGE444

## 13.0 TROUBLE SHOOTING

SYMPTOM	POSSIBLE CAUSE	REMEDY
Leaks	Debris or damage in seal area	Clean out debris or replace damaged parts
Binding, Erratic operation	Low Voltage (see below)	See Below
Does not raise	Low voltage due to: - wire gage too small - wire length too long - poor connection - inadequate apparatus electrical system	Check connections and wiring per section 7.3
	Mechanical Binding	Use manual override to verify mechanical operation.
Does not lower	Low voltage due to: - wire gage too small - wire length too long - poor connection - inadequate apparatus electrical system	Check connections and wiring per section 7.3
	Mechanical Binding	Use manual override to verify mechanical operation.
	Monitor not in PARK/STOW position.	Perform Monitor PARK/STOW operation.

## 14.0 MAINTENANCE AND INSPECTION

The Extend-A-Gun RC requires little maintenance. The Extend-A-Gun RC should be kept clean and free of dirt. All controls should be checked for freedom of movement and proper operation before each use. Any inoperable or damaged parts should be repaired or replaced immediately. Consult factory for recommended service procedure.

- Make sure that the Extend-A-Gun RC handwheel rotates freely and without binding throughout its range of travel.
- Make sure that there are no leaks when the Extend-A-Gun RC is flowing water.

### 14.1 LUBRICATION

The Extend-A-Gun RC is permanently lubricated on the cup seal and ACME threads. If lubricant has been removed during service, then apply a thin film of White Lithium Grease on seal surfaces and on ACME threaded surfaces.

## **16.0 WARRANTY FOR EXTEND-A-GUN RC**

Task Force Tips, Inc., 2800 East Evans Avenue, Valparaiso, Indiana 46383-6940 ("TFT") warrants to the original purchaser of its Extend-A-Gun RC Telescoping Waterway ("equipment"), and to anyone to whom it is transferred, that the equipment shall be free from defects in material and workmanship during the five (5) year period from the date of purchase.

TFT's obligation under this warranty is specifically limited to replacing or repairing the equipment (or its parts) which are shown by TFT's examination to be in a defective condition attributable to TFT. To qualify for this limited warranty, the claimant must return the equipment to TFT, at 2800 East Evans Avenue, Valparaiso, Indiana 46383-6940, within a reasonable time after discovery of the defect. TFT will examine the equipment. If TFT determines that there is a defect attributable to it, it will correct the problem within a reasonable time. If the equipment is covered by this limited warranty, TFT will assume the expenses of repair.

If any defect attributable to TFT under this limited warranty cannot be reasonably cured by repair or replacement, TFT may elect to refund the purchase price of the equipment, less reasonable depreciation, in complete discharge of its obligations under this limited warranty. If TFT makes this election, claimant shall return the equipment to TFT free and clear of any liens and encumbrances.

This is a limited warranty. The original purchaser of the equipment, any person to whom it is transferred, and any person who is an intended or unintended beneficiary of the equipment, shall not be entitled to recover from TFT any consequential or incidental damages for injury to person and/or property resulting from any defective equipment manufactured or assembled by TFT. It is agreed and understood that the price stated for the equipment is in part consideration for limiting TFT's liability. Some states do not allow the exclusion or limitation of incidental or consequential damages, so the above may not apply to you.

TFT shall have no obligation under this limited warranty if the equipment is, or has been, misused or neglected (including failure to provide reasonable maintenance) or if there have been accidents to the equipment or if it has been repaired or altered by someone else.

**THIS IS A LIMITED EXPRESS WARRANTY ONLY. TFT EXPRESSLY DISCLAIMS WITH RESPECT TO THE EQUIPMENT ALL IMPLIED WARRANTIES OF MERCHANTABILITY AND ALL IMPLIED WARRANTIES OF FITNESS FOR A PARTICULAR PURPOSE. THERE IS NO WARRANTY OF ANY NATURE MADE BY TFT BEYOND THAT STATED IN THE DOCUMENT.**

This limited warranty gives you specific legal rights, and you may also have other rights which vary from state to state.

***TASK FORCE TIPS, Inc.***  
***Made in USA • www.tft.com***

***2800 E Evans Ave • Valparaiso , IN 46383-6940 USA***  
***800-348-2686 • 219-462-6161 • Fax 219-464-7155***