

# EXTEND-A-GUN

## MODEL XG12 Telescoping Waterway for Deck Mounted Monitors

### INSTALLATION and OPERATING INSTRUCTIONS

#### **⚠ DANGER**

Read instruction manual before use. Operation of this device without understanding the manual and receiving proper training is a misuse of this equipment. A person who has not read and understood all operating and safety instructions, is not qualified to operate the Extend-A-Gun telescoping unit.

To make the Extend-A-Gun as versatile as possible three mounting bracket kits are offered. Each kit has a different upper bracket, the lower bracket is the same in all three.

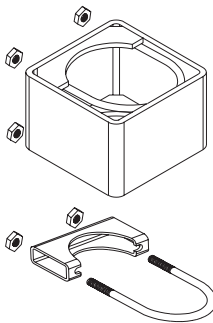

XGB-13 TUBE/SADDLE BRACKET SET

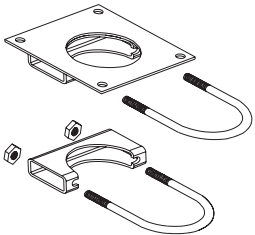

XGB-23 PLATE/SADDLE BRACKET SET

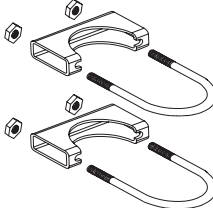

XGB-33 SADDLE/SADDLE BRACKET SET

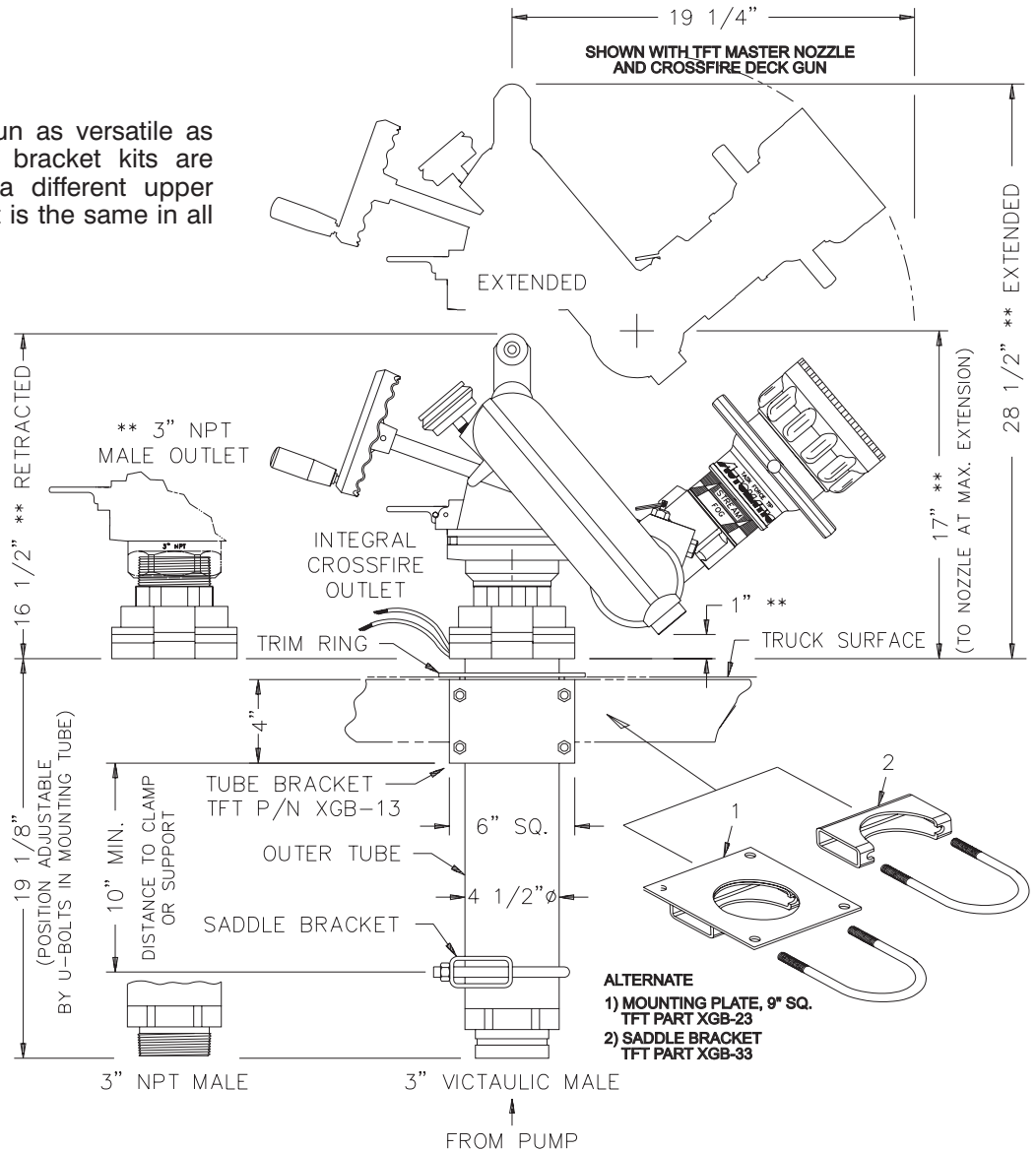

\*\* - OUTLETS SHOWN ARE FOR MODELS XG12PL - XL & XG12-VL-XL FOR MODELS WITH 3" MAKE NPT OUTLET, ADD 1"

**TASK FORCE TIPS, Inc.**  
Made in USA • www.tft.com

2800 E Evans Ave • Valparaiso, IN 46383-6940 USA  
800-348-2686 • 219-462-6161 • Fax 219-464-7155

## TABLE OF CONTENTS

- 1.0 MEANING OF SIGNAL WORDS
- 2.0 GENERAL INFORMATION
- 3.0 BRACKET SETS
  - 3.1 TUBE BRACKET INSTALLATION
  - 3.2 SADDLE BRACKET INSTALLATION
  - 3.3 PLATE BRACKET INSTALLATION
- 4.0 SIDE LOADS AT MOUNTING POINTS
- 5.0 INDICATOR SWITCH WIRING
- 6.0 LABELS
- 7.0 MOUNTING MONITORS
- 8.0 OPERATING INSTRUCTIONS
  - 8.1 EXTEND
  - 8.2 RETRACT
  - 8.3 INDICATOR LIGHT
- 9.0 EXPLODED VIEW & PARTS LIST
- 10.0 WARRANTY

### **DANGER**

#### PERSONAL RESPONSIBILITY CODE

The member companies of FEMSA that provide emergency response equipment and services want responders to know and understand the following:

1. Firefighting and Emergency Response are inherently dangerous activities requiring proper training in their hazards and the use of extreme caution at all times.
2. It is your responsibility to read and understand any user's instructions provided with any piece of equipment you may be called upon to use.
3. It is your responsibility to know that you have been properly trained in Firefighting and /or Emergency Response and in the use, precautions, and care of any equipment you may be called upon to use.
4. It is your responsibility to be in proper physical condition and to maintain the personal skill level required to operate any equipment you may be called upon to use.
5. It is your responsibility to know that your equipment is in operable condition and has been maintained in accordance with the manufacturer's instructions.
6. Failure to follow these guidelines may result in death, burns or other severe injury.



Fire and Emergency Manufacturers and Services Association, Inc.  
P.O. Box 147, Lynnfield, MA 01940 • [www.FEMSA.org](http://www.FEMSA.org)

## 1.0 MEANING OF SIGNAL WORDS

A safety related message is identified by a safety alert symbol and a signal word to indicate the level of risk involved with a particular hazard. Per ANSI standard Z535.4-1998 the definitions of the three signal words are as follows:

 **DANGER** indicates an imminently hazardous situation which, if not avoided, will result in death or serious injury.

 **WARNING** indicates a potentially hazardous situation which, if not avoided, could result in death or serious injury.

 **CAUTION** indicates a potentially hazardous situation which, if not avoided, may result in minor or moderate injury.

## 2.0 GENERAL INFORMATION

 **DANGER** When operating the Extend-A-Gun you may be in a precarious position. Watch your footing on top of the truck. It can become very slippery. It is possible to fall

 **WARNING** The Extend-A-Gun may be used in either the raised or the lowered position, but not in-between. Make sure that the slide bar is down and both pawls are flush with the housing before use. If the word "UNLOCKED" is visible, the Extend-A-Gun is unlocked and may rise suddenly if it is in the lowered position and the water is turned on or fall suddenly if it is in the raised position and the water is turned off. When the pawls are flush with the housing, and the water is turned on, the pawls are locked in position and prevent the latch mechanism from operating.

 **WARNING** Do not plug or cap the Extend-A-Gun or mounted deck gun while it is in the raised position. This will prevent the Extend-A-Gun from being lowered all the way and the latch pawls will not lock.

 **WARNING** For safe dependable service, the Extend-A-Gun must be securely mounted.

 **WARNING** The forces acting on the mounting brackets, when the Extend-A-Gun is in the extended position, are higher than the forces in a normal deck gun installation.

 **WARNING** Keep the upper and lower brackets as far apart as possible to minimize the amount of stress on the upper and lower brackets.

 **WARNING** Master stream flows are very powerful and capable of causing injury and property damage. Make sure the monitor is pointing in a safe direction before water to the monitor is turned on. Use care in directing the stream.

 **CAUTION** Do not lift the slide bar when water is flowing, the mechanism will not unlatch, but the mechanism can be damaged.

 **CAUTION** Do not lift the slide bar to lower the deck gun without supporting the weight of the deck gun. It can fall and cause injury.

### 3.0 BRACKET SETS

For safe dependable service, the Extend-A-Gun **MUST** be securely mounted. To make the Extend-A-Gun as versatile as possible, three mounting bracket kits are offered. Each kit has a different upper bracket. The lower bracket is the same in all three.

#### **WARNING**

**Task Force Tips strongly recommends that Extend-A-Gun be installed using the bracket sets, sold by Task Force Tips, that are designed for this purpose. For the Extend-A-Gun to operate safely and properly, it must be installed in such a way that the brackets can withstand the forces resulting from the nozzle reaction force. The Task Force Tips bracket sets are designed to fit the Extend-A-Gun outer tube very closely to prevent distortion of the outer tube and to give it adequate support.**

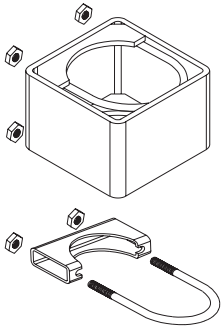

**XGB-13**  
TUBE/SADDLE BRACKET SET

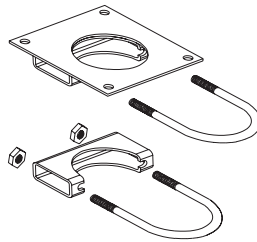

**XGB-23**  
PLATE/SADDLE BRACKET SET

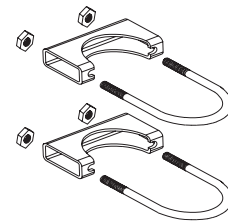

**XGB-33**  
SADDLE/SADDLE BRACKET SET

### 3.1 TUBE BRACKET INSTALLATION

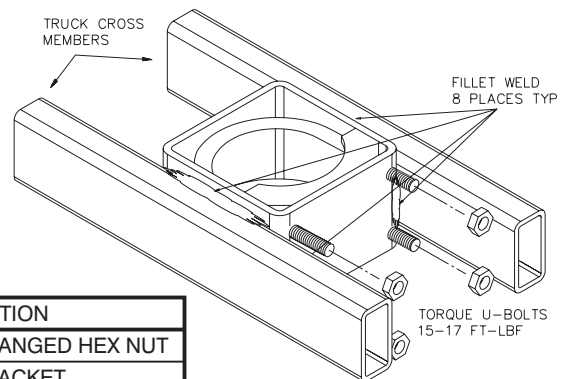
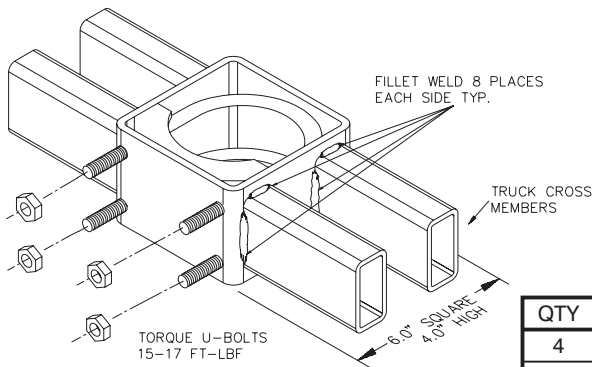

QTY	PART	DESCRIPTION
4	VT37-16FNT	3/8-16 FLANGED HEX NUT
1	XG480	TUBE BRACKET
2	XG475	4-1/2 U-BOLT 3/8 DIA.

#### TUBE BRACKET WELDING

This kit contains a six inch square steel tube with two U-bolts to be used as the upper bracket and a saddle bracket, similar to a heavy duty muffler clamp for the lower bracket. Both brackets must be used. This kit is designed primarily for installation in trucks as they are being built at the factory. The tube bracket may be welded onto the truck tubular framework, as shown on the Tube Bracket Welding Diagram. The lower bracket, as shown in the Saddle Bracket Welding Diagrams, should be welded to an additional support and clamped as low as possible on the bottom of the Extend-A-Gun tube. Make sure the welds are capable of withstanding the forces shown on the Side Loads At Mounting Points Diagram. The Extend-A-Gun may be installed in the brackets after the truck is painted. Use Loctite, supplied in kit on U-bolt threads, and torque nuts on upper U-bolts to 15-17 ft-lbf, torque nuts on lower U-bolts to 36-40 ft-lbf.

### 3.2 SADDLE BRACKET INSTALLATION

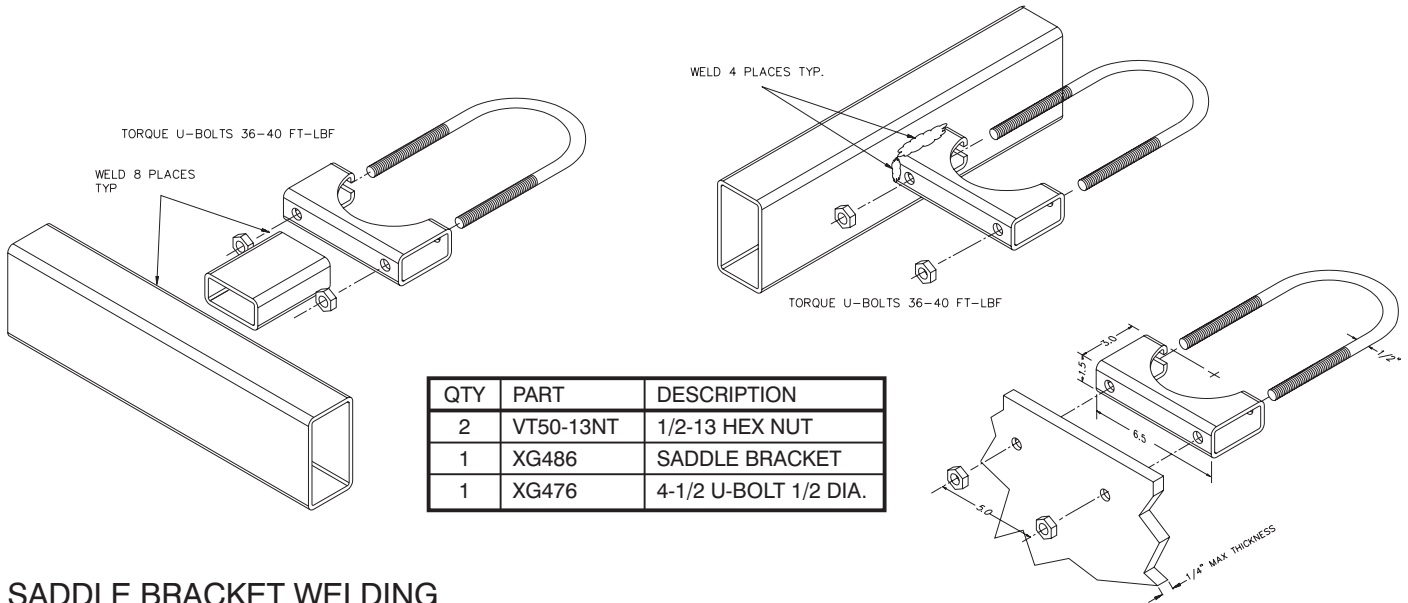

### SADDLE BRACKET WELDING

This kit contains two mild steel saddle brackets and U-bolts, and is designed for factory installation on new equipment. Both Brackets must be used. Both brackets are to be welded to truck framework as far apart as possible yet still clamp on the Extend-A-Gun tube. The welds must be able to withstand the forces shown on the Side Loads at Mounting Points Diagram. The Extend-A-Gun may be installed in the brackets after the truck is painted. Use Loctite, supplied in kit on U-bolt threads, and torque nuts on U-bolts to 36-40 ft-lbf.

### 3.3 PLATE BRACKET INSTALLATION

This kit may be used in either new or retro-fit installations. The top plate with its bracket may be bolted above or below an existing deck. The lower saddle bracket is installed as previously shown. Both brackets must be used. To minimize the stress on the brackets they should be as far apart as possible when clamped to the Extend-A-Gun tube. Please refer to the Side Loads at Mounting Points Diagram and make sure the mounting points can withstand these forces. Use Loctite®, supplied in kit on all threads, torque bolts to 40-45 ft-lbf and nuts on U-bolts to 36-40 ft-lbf.

QTY	PART	DESCRIPTION
2	VT50-13NT	1/2-13 HEX NUT
1	XG485	MOUNTING PLATE
1	XG476	4-1/2 U-BOLT 1/2 DIA.

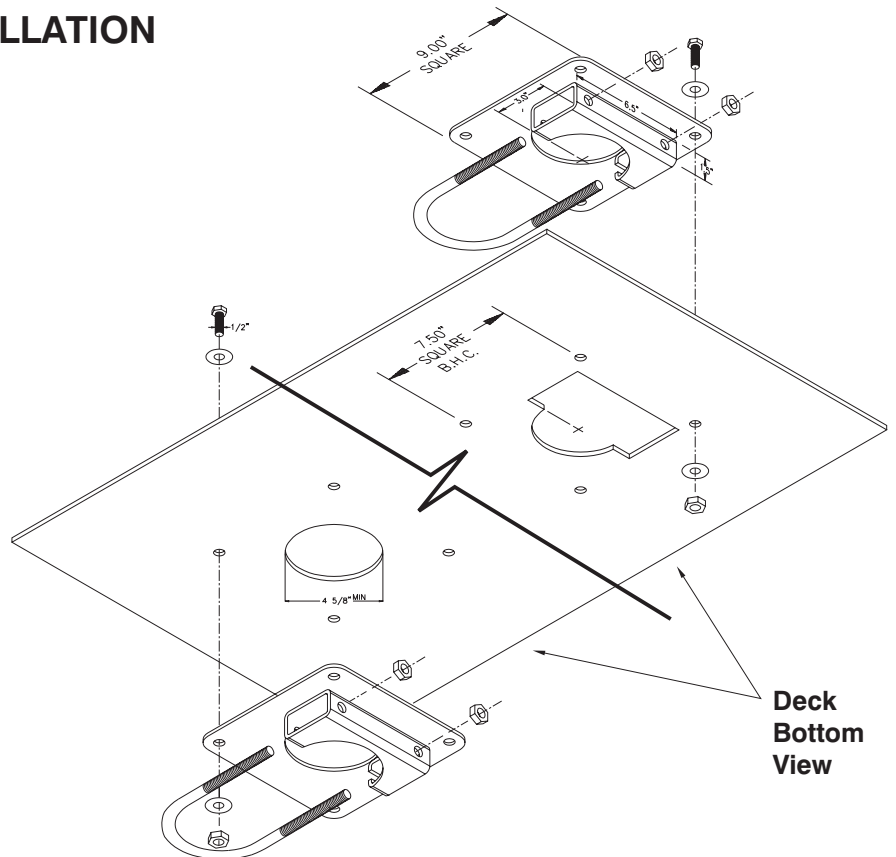

## 4.0 SIDE LOADS AT MOUNTING POINTS

**WARNING** Before installing the Extend-A-Gun you **MUST** determine the forces that will be exerted in the proposed installation by the reaction force of the nozzle.

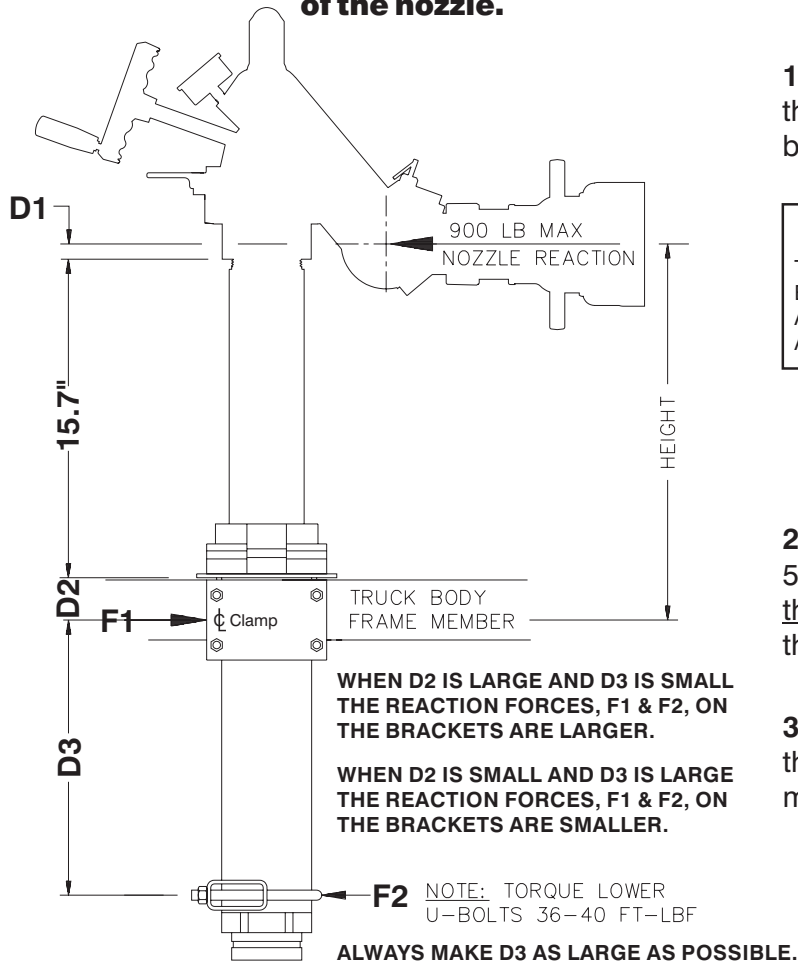

1) Determine the distance, D1, in inches, from the center of the monitor elevation joint to the bottom of the threads in the monitor inlet.

### D1 FOR MOST COMMON INSTALLATIONS

Task Force Tips CROSSFIRE	D1 = 1"
Elkhart Stinger Mod. 8297-98 w/ companion flange	D1 = 6"
Akron Apollo Mod. 3422 w/ companion flange	D1 = 5"
Akron Apollo Mod. 3422 threaded on	D1 = 4"

D1 =  inches

2) Locate the value of D1, in the charts on page 5. Find the desired HEIGHT from the center of the upper bracket to the center of the stream in the HEIGHT column.

3) Locate D2, the distance from the bottom of the latch casting to the center of the upper mounting bracket, for the chosen HEIGHT.

D2 =  inches

### Crossfire

D1	D2	HEIGHT	D3 min	D3 max
1	1	18	7	14
	2	19	8	13
	3	20	8	12
	4	21	8	11
	5	22	9	10
	6	23	9	9

### Apollo Intergral Threads

D1	D2	HEIGHT	D3 min	D3 max
4	1	21	8	14
	2	22	9	13
	3	23	9	12
	4	24	10	11
	5	25	10	10

D1	D2	HEIGHT	D3 min	D3 max
7	1	24	10	14
	2	25	10	13
	3	26	11	12
	4	27	11	11

D1	D2	HEIGHT	D3 min	D3 max
2	1	19	8	14
	2	20	8	13
	3	21	8	12
	4	22	9	11
	5	23	9	10

### Apollo Flange

D1	D2	HEIGHT	D3 min	D3 max
5	1	22	9	14
	2	23	9	13
	3	24	10	12
	4	25	10	11

D1	D2	HEIGHT	D3 min	D3 max
8	1	25	10	14
	2	26	11	13
	3	27	11	12
	4	28	11	11

D1	D2	HEIGHT	D3 min	D3 max
3	1	20	8	14
	2	21	8	13
	3	22	9	12
	4	23	9	11
	5	24	10	10

### Stinger

D1	D2	HEIGHT	D3 min	D3 max
6	1	23	9	14
	2	24	10	13
	3	25	10	12
	4	26	11	11

D1	D2	HEIGHT	D3 min	D3 max
9	1	26	11	14
	2	27	11	13
	3	28	11	12

### CHART FOR MODEL XG-12 ONLY

D1	D2	HEIGHT	D3 min	D3 max
10	1	27	11	14
	2	28	11	13
	3	29	12	12

4) Determine the distance, D3 in inches, from the center of the upper mounting bracket to the center of the lower mounting bracket for the proposed installation. **D3 MUST be between D3 min and D3 max.** D3 =  inches

5) Calculate forces on Brackets, Add D1 + D2 + D3 + 15.7 =  
 D1  + D2  + D3  + 15.7 = L  inches

6) Multiply L x 900  
 L  x 900 = M  inch • pounds

7) Divide M by D3  
 M  / D3  = F1  pounds

8) Subtract 900 from F1  
 F1  - 900 = F2  pounds

**NOTE:** F1 **MUST** be less than 3100 lbf. F2 **MUST** be less than 2200 lbf.  
 And the proposed installation **MUST** be capable of withstanding forces of this magnitude.

**⚠ WARNING** Injury can result from an inadequately supported monitor. The monitor mount must be capable of supporting the nozzle reaction force which can be as high as 900 lbf. (400 kg). Flanges and pipe made from plastic are inadequate for monitor mounting and must not be used.

## 5.0 INDICATOR SWITCH WIRING

The Extend-A-Gun latch mechanism contains a magnetic switch. This switch is intended to be used with a MONITOR EXTENDED warning light. The magnetic switch in the Extend-A-Gun is a normally open switch, and the switch is closed when the Extend-A-Gun is in the down position. **The enclosed relay MUST BE USED** to limit the current through the switch.

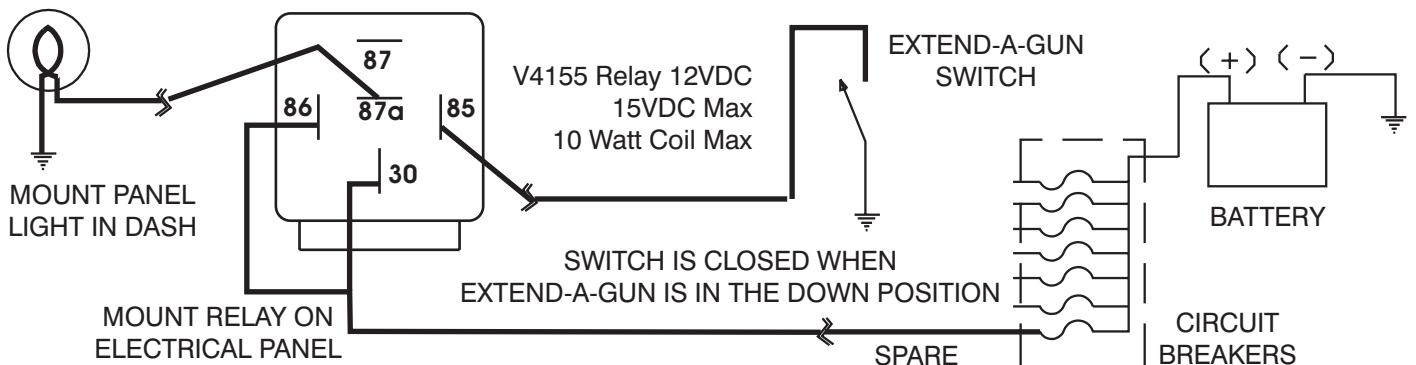

- 1) Screw the threaded switch body into the tapped hole in the Extend-A-Gun latch casting after the Extend-A-Gun is permanently installed. Be careful not to twist or break the wires.
- 2) Mount the relay on the electrical panel with the terminals accessible.
- 3) Drill a 1/2" diameter hole in the dash board for the panel light. Leave enough room for a 1-13/16" diameter label around the light or a 2" wide x 1-1/2" high label next to the light. Apply one of the two warning labels and push the panel light through the hole in the dash.
- 4) Connect the labeled wires on the switch to terminal #85 on the relay and ground respectively.
- 5) Connect the terminals on the panel light to terminal #87A on the relay and ground respectively.
- 6) Connect a wire from a "spare" position on the trucks circuit breaker panel to terminals #30 and #86. The circuit from the "spare" position in the fuse block should only be energized when the ignition switch is in the ON position.

## 6.0 LABELS

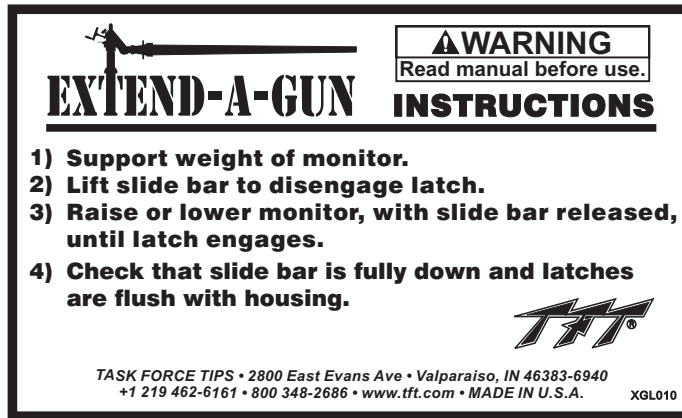

Attach the rectangular instruction label (XGL010) to a smooth flat surface where it can be read by the person operating the Extend-a-Gun and monitor.

Attach the warning label (XGL020) next to the indicator light or warning label (XGL025) around the indicator light on the truck dashboard.



## 7.0 MOUNTING MONITORS

A Task Force Tips Crossfire® monitor may be mounted in one of two ways. We recommend that it be mounted directly on Extend-A-Gun models XG12PL-XL, XG12VL-XL, XG18PL-XL, or XG18VL-XL, which have integral Crossfire bases built in. Alternatively, it can be mounted on Extend-A-Gun models XG12PL-PL, XG12VL-PL, XG18PL-PL, or XG18VL-PL using Task Force Tips part XFF-APL Truck Mount Base, which fits only the Task Force Tips Crossfire.

Akron Apollo® monitors may be mounted on Extend-A-Gun models XG12PL-PL, XG12VL-PL, XG18PL-PL, or XG18VL-PL in one of two ways. We recommend that the direct mount flange be screwed directly to the 3" pipe threads on the Extend-A-Gun. The base may be modified by having the flange turned down to 5" diameter at your local machine shop. Alternatively, the direct mount flange can be bolted to Task Force Tips part XFF-CPL Companion Flange (or equivalent) with out modification. Make sure that the flange bolts do not interfere with the Extend-A-Gun latch mechanism.

Elkhart Stinger® monitors must be bolted to Extend-A-Gun models XG12PL-PL, XG12VL-PL, XG18PL-PL, or XG18VL-PL using Task Force Tips part XFF-CPL Companion Flange (or equivalent). Make sure the flange bolts do not interfere with the Extend-A-Gun latch mechanism.

## 8.0 OPERATING INSTRUCTIONS



**The Extend-A-Gun may be used in either the extended or retracted position, but not in-between. Make sure the slide bar is down and both pawls are flush with the housing before use. The word "UNLOCKED" located on the top of the pawls should not be visible. When in use, the pawls are locked in position and prevent the latch mechanism from operating.**



**Do not attempt to raise the Extend-A-Gun with water pressure. Rapid upward movement of the Extend-A-Gun can cause injury to persons by striking them, or knocking them off the fire truck. It can also cause damage to the Extend-A-Gun, monitor, or other equipment.**



**Do not lift the slide bar when flowing water. The mechanism will not unlatch, but the mechanism can be damaged.**



**Do not lift the slide bar to lower the deck gun with out supporting the weight of the deck gun. It can fall and cause injury.**



## 8.1 EXTEND

- 1) Make certain the valve to the deck gun is closed.
- 2) Lift the slide bar on the Extend-A-Gun latch mechanism with one hand and lift the deck gun straight up with your other hand. The slide bar should be released after the deck gun has moved out of the retracted position. Notice the word "UNLOCKED" appear on the top surface of the pawls.
- 3) When the deck gun is in the extended position it will not be possible to lift it any higher. The pawls will retract, the slide bar will move down flush with the housing and the word "UNLOCKED" is no longer visible.
- 4) Make certain that the pawls are flush with the sides of the housing and that the word "UNLOCKED" is not visible before operating the valve to the deck gun.

## 8.2 RETRACT

- 1) Make certain the valve to the deck gun is closed.
- 2) Lift the deck gun slightly with one hand to take the weight off the latch mechanism and lift the slide bar with your other hand. Notice the word "UNLOCKED" appears on the top surface of the pawls.
- 3) Lower the deck gun to the retracted position. The slide bar should be released after the deck gun leaves the extended position.
- 4) Make certain that both pawls are flush with the sides of the housing and that the word "UNLOCKED" is not visible before opening the valve to the deck gun.

## 8.3 INDICATOR LIGHT

The Extend-A-Gun has a built in switch to control an indicator light on the truck dash board showing that the Extend-A-Gun is in the the extended position. This is to help prevent damage that would occur if the deck gun hits a low overhanging object.. **Do not move the truck with the Extend-A-Gun in the extended position.**

# 9.0 EXPLODED VIEW AND PARTS LIST

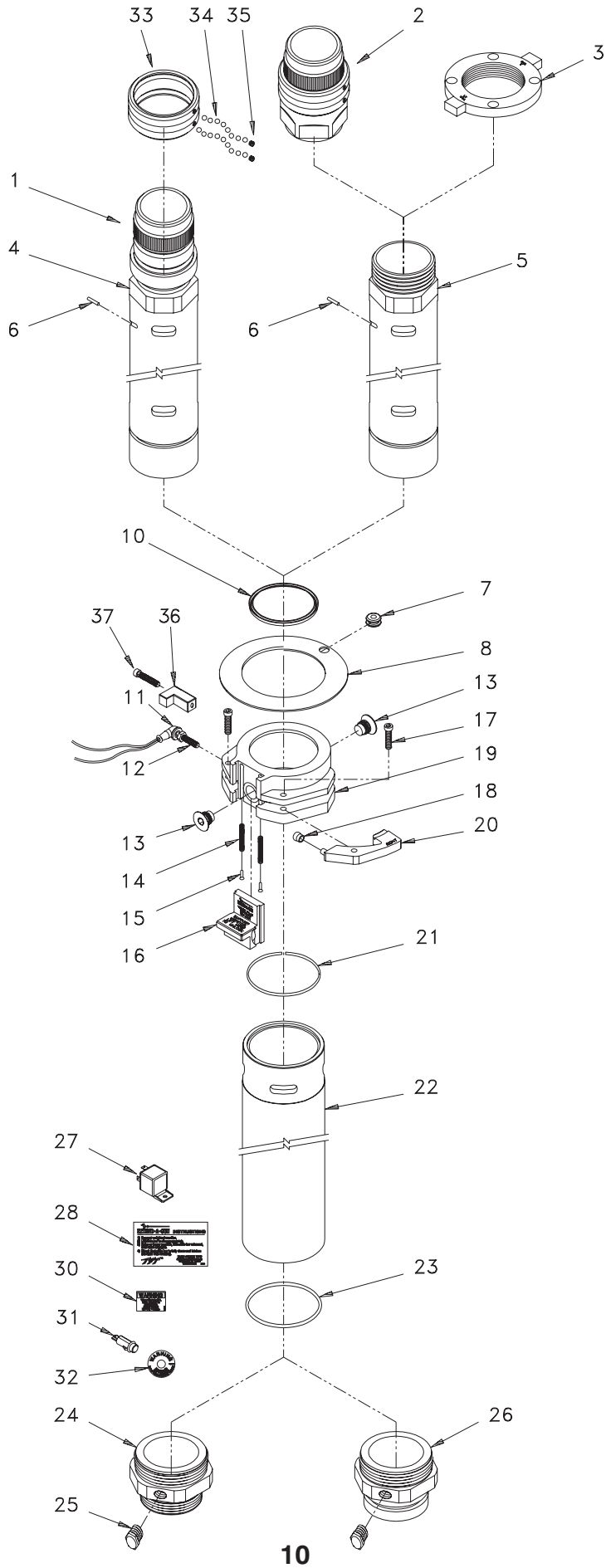

# EXTEND-A-GUN

## MODEL XG12

	Description	Qty	Order #
1*	Extend-A-Gun Base	1	X412
2*	3" Truck Adaptor	1	XFF-APL
3	3" Companion Flange	1	X415
4	12" Inner Tube 3" BSP	1	XG312BL
5	12" Inner Tube 3" NPT	1	XG312PL
6	Cylindrical Magnet	1	VM4152
7	Rubber Grommet	1	XG472
8	Trim Ring	1	XG470
10	Cup Seal	1	XG125
11	Rubber Terminal Boot	1	VM4165
12	Threaded Reed Switch	1	VM4144
13	Stop Screw	2	XG120
14	Slide Spring	2	XG141
15	Flush Pin	2	H790
16	Slide Bar	1	XG140
17	5/16-18 x 1 ¼ SHCS	2	VT31-18SH1.2
18	Roller	2	XG130
19	Bell	1	XG110
20	Right Pawl	1	XG135R
	Left Pawl (not shown)	1	XG135L
21	SF Wearstrip	1	M515
22	12" Outer Tube	1	XG412
23	O-Ring-343	1	VO-343
24	3" Male NPT Inlet	1	XG405PL
25	1/2-14 NPT Pipe Plug	1	VT50-14PP
26	3" Male Victaulic Inlet	1	XG405VL
27	12 V Switching Relay	1	V4155
28	Instruction Label	1	XGL010
30	Dashboard Label	1	XGL020
31	Indicator Light	1	VM4156
32	Round Dash Label	1	XGL025
33	Swivel Ring	1	X425
34	5/16 SS Ball	78	VB.312
35	Swivel Screw	2	X405
36	Switch Protector	1	XG115
37	1/4-20 x 1-1/4 SHCS	1	VT25-20SH1.2

*\*For Crossfire Only*

## 10.0 WARRANTY FOR EXTEND-A-GUN

Task Force Tips, Inc., 2800 East Evans Avenue, Valparaiso, Indiana 46383-6940 ("TFT") warrants to the original purchaser of its Extend-A-Gun Telescoping Waterway ("equipment"), and to anyone to whom it is transferred, that the equipment shall be free from defects in material and workmanship during the five (5) year period from the date of purchase.

TFT's obligation under this warranty is specifically limited to replacing or repairing the equipment (or its parts) which are shown by TFT's examination to be in a defective condition attributable to TFT. To qualify for this limited warranty, the claimant must return the equipment to TFT, at 2800 East Evans Avenue, Valparaiso, Indiana 46383-6940, within a reasonable time after discovery of the defect. TFT will examine the equipment. If TFT determines that there is a defect attributable to it, it will correct the problem within a reasonable time. If the equipment is covered by this limited warranty, TFT will assume the expenses of repair.

If any defect attributable to TFT under this limited warranty cannot be reasonably cured by repair or replacement, TFT may elect to refund the purchase price of the equipment, less reasonable depreciation, in complete discharge of its obligations under this limited warranty. If TFT makes this election, claimant shall return the equipment to TFT free and clear of any liens and encumbrances.

This is a limited warranty. The original purchaser of the equipment, any person to whom it is transferred, and any person who is an intended or unintended beneficiary of the equipment, shall not be entitled to recover from TFT any consequential or incidental damages for injury to person and/or property resulting from any defective equipment manufactured or assembled by TFT. It is agreed and understood that the price stated for the equipment is in part consideration for limiting TFT's liability. Some states do not allow the exclusion or limitation of incidental or consequential damages, so the above may not apply to you.

TFT shall have no obligation under this limited warranty if the equipment is, or has been, misused or neglected (including failure to provide reasonable maintenance) or if there have been accidents to the equipment or if it has been repaired or altered by someone else.

**THIS IS A LIMITED EXPRESS WARRANTY ONLY. TFT EXPRESSLY DISCLAIMS WITH RESPECT TO THE EQUIPMENT ALL IMPLIED WARRANTIES OF MERCHANT ABILITY AND ALL IMPLIED WARRANTIES OF FITNESS FOR A PARTICULAR PURPOSE. THERE IS NO WARRANTY OF ANY NATURE MADE BY TFT BEYOND THAT STATED IN THE DOCUMENT.**

This limited warranty gives you specific legal rights, and you may also have other rights which vary from state to state.

**TASK FORCE TIPS, Inc.**  
Made in USA • [www.tft.com](http://www.tft.com)

2800 E Evans Ave • Valparaiso , IN 46383-6940 USA  
800-348-2686 • 219-462-6161 • Fax 219-464-7155