



# MANUAL: HURRICANE & HURRICANE RC MONITOR

See Remote Control (RC) Monitor Electrical Controls Supplemental Instructions For Use With Hurricane RC Models (LIY-500)

## INSTRUCTIONS FOR INSTALLATION, SAFE OPERATION AND MAINTENANCE

**⚠ DANGER**

Understand manual before use. Operation of this device without understanding the manual and receiving proper training is a misuse of this equipment. Obtain safety information at [www.tft.com/serial-number](http://www.tft.com/serial-number)

This Instruction Manual is intended to familiarize firefighters and maintenance personnel with the operation, servicing, and safety procedures associated with this product. This manual should be kept available to all operating and maintenance personnel.

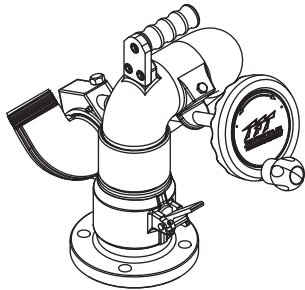

Hurricane Extended

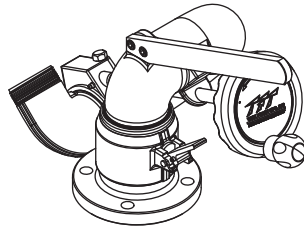

Hurricane

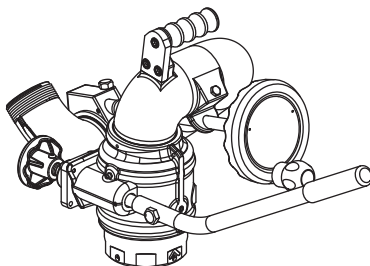

Hurricane Tiller for 4.5" Quick  
Connect  
and Valve Under Monitor

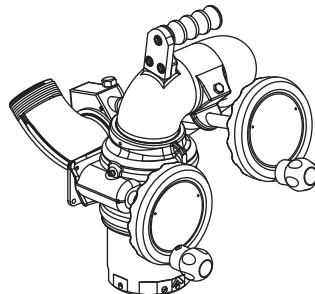

Hurricane Dual Handwheel

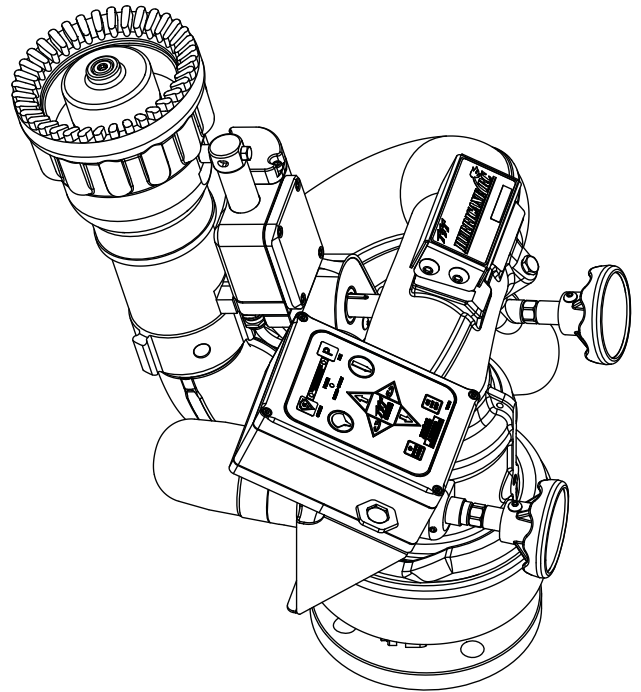

**HURRICANE**

**HURRICANE RC**

See Section 3.1 for Flow / Pressure  
Operating Envelope

**TASK FORCE TIPS, INC.**  
MADE IN USA • [www.tft.com](http://www.tft.com)

3701 Innovation Way, Valparaiso, IN 46383-9327 USA  
800-348-2686 • 219-462-6161 • Fax 219-464-7155

## Table Of Contents

|   |  |
|---|--|
| <p>1.0 Meaning of Safety Signal Words ..... 2</p> <p>2.0 Safety ..... 3</p> <p>3.0 General Information ..... 3-12</p> <p style="padding-left: 20px;">3.1 Mechanical Specifications</p> <p style="padding-left: 20px;">3.2 Part Identification and Models</p> <p style="padding-left: 20px;">3.3 Inlets and Outlets</p> <p style="padding-left: 20px;">3.4 Overall Dimensions</p> <p>4.0 Installation ..... 12-17</p> <p style="padding-left: 20px;">4.1 Structural Requirements for Monitor Mounting</p> <p style="padding-left: 40px;">4.1.1 Water Supply</p> <p style="padding-left: 20px;">4.2 Inlet Mounting and Travel Ranges</p> <p style="padding-left: 40px;">4.2.1 Inlet Fitting or Extend-A-Gun RC Installation</p> <p style="padding-left: 40px;">4.2.2 Horizontal Rotation Travel Stops</p> <p style="padding-left: 40px;">4.2.3 Vertical Rotation Travel Stops</p> <p style="padding-left: 20px;">4.3 Nozzle Installation</p> <p style="padding-left: 20px;">4.4 Pressure Gage Port</p> <p style="padding-left: 20px;">4.5 Automatic Drain</p> <p style="padding-left: 20px;">4.6 Handle Installation</p> <p>5.0 Operation ..... 17</p> <p style="padding-left: 20px;">5.1 Horizontal Rotation Control</p> <p style="padding-left: 20px;">5.2 Elevation Control</p> <p style="padding-left: 20px;">5.3 Recommended Park Position</p> <p style="padding-left: 20px;">5.4 Override Knobs</p> <p>6.0 Flows and Pressures..... 18-21</p> <p style="padding-left: 20px;">6.1 Stacked Tips Flow and Reach</p> <p style="padding-left: 20px;">6.2 Automatic Masterstream Nozzles</p> <p style="padding-left: 20px;">6.3 Stream Straighteners</p> <p style="padding-left: 40px;">6.3.1 Stream Straighteners with Stacked Tips</p> <p style="padding-left: 40px;">6.3.2 Stream Straighteners with Fog Nozzles</p> <p>7.0 Maintenance and Inspection ..... 22</p> <p style="padding-left: 20px;">7.1 Lubrication</p> <p style="padding-left: 40px;">7.1.1 Elevation Control Worm Gear</p> <p style="padding-left: 40px;">7.1.2 Horizontal Rotation Worm Gear</p> <p>8.0 Troubleshooting ..... 22</p> | <p>9.0 Drawings and Parts List ..... 23-35</p> <p style="padding-left: 20px;">9.1 Hurricane Fixed (XFI Series)</p> <p style="padding-left: 20px;">9.2 Hurricane Fixed Extended (XFIBE Series)</p> <p style="padding-left: 20px;">9.3 Hurricane Dual Handwheel (XFIH-D Series)</p> <p style="padding-left: 20px;">9.4 Hurricane Tiller for 4.5" Quick Connect and V.U.M. (XFIH-T Series)</p> <p style="padding-left: 20px;">9.5 Hurricane RC Monitor (XFIH-E Series)</p> <p style="padding-left: 20px;">9.6 Elevation Chain Drive Assembly</p> <p style="padding-left: 20px;">9.7 Gear Motor Assembly</p> <p style="padding-left: 20px;">9.8 Monitor Control Box Assembly</p> <p>10.0 Warranty ..... Back Cover</p> |
|---|--|



**PERSONAL RESPONSIBILITY CODE**

The member companies of FEMSA that provide emergency response equipment and services want responders to know and understand the following:





1. Firefighting and Emergency Response are inherently dangerous activities requiring proper training in their hazards and the use of extreme caution at all times.
2. It is your responsibility to read and understand any user's instructions, including purpose and limitations, provided with any piece of equipment you may be called upon to use.
3. It is your responsibility to know that you have been properly trained in Firefighting and/or Emergency Response and in the use, precautions, and care of any equipment you may be called upon to use.
4. It is your responsibility to be in proper physical condition and to maintain the personal skill level required to operate any equipment you may be called upon to use.
5. It is your responsibility to know that your equipment is in operable condition and has been maintained in accordance with the manufacturer's instructions.
6. Failure to follow these guidelines may result in death, burns or other severe injury.



Fire and Emergency Manufacturers and Service Association  
 P.O. Box 147, Lynnfield, MA 01940 • www.FEMSA.org

### 1.0 MEANING OF SAFETY SIGNAL WORDS

A safety related message is identified by a safety alert symbol and a signal word to indicate the level of risk involved with a particular hazard. Per ANSI standard Z535.6-2011, the definitions of the four signal words are as follows:

- |  |   |
|--|---|
|  | <b>DANGER</b> indicates a hazardous situation which, if not avoided, will result in death or serious injury.                |
|  | <b>WARNING</b> indicates a hazardous situation which, if not avoided, could result in death or serious injury.              |
|  | <b>CAUTION</b> indicates a potentially hazardous situation which, if not avoided, could result in minor or moderate injury. |
|  | <b>NOTICE</b> is used to address practices not related to physical injury.  |

## 2.0 SAFETY

The operation of this monitor can be dangerous. The following must be observed at all times.

- ⚠ WARNING** Injury or death may occur by attempting to use a damaged monitor. Before using the monitor inspect it for damage resulting from:
- Failure to drain monitor followed by exposure to freezing conditions
  - Exposure of monitor to temperatures in excess of 160 degrees F
  - Structural damage caused by over-pressurization
  - Missing parts, physical abuse, exposure to severe chemicals
  - Deformed or cracked flanges damaged as a result of improper installation
    - Excessive bolt torque
    - Wrong tightening sequence
- ⚠ WARNING** Injury can result from an inadequately supported monitor. The monitor mount must be capable of supporting 940 lbs (430 kg) of nozzle reaction force.
- ⚠ WARNING** The stream exiting a monitor is very powerful and capable of causing injury and property damage. Make sure the monitor is securely attached to the base and pointing in a safe direction before water to the monitor is turned on. Use care in directing the stream.
- ⚠ WARNING** The monitor may be damaged if frozen while containing sufficient amounts of water. Such damage may be difficult to detect visually and can lead to possible injury or death. Any time the monitor is subject to possible damage from freezing, it must be hydrostatically tested by qualified personnel before being considered safe for use.
- ⚠ CAUTION** The electric Hurricane RC may be remotely operated. The electric drives are current limited but may still produce enough force to cause injury. Keep hands and fingers away from pinch points on the monitor.
- ⚠ CAUTION** Do not use the manual override knobs while the electric controls are in operation. The electric drives produce enough torque to cause injury.
- ⚠ CAUTION** Maximum flow and pressure is 1250 gpm (5000 l/min) and 200 psi (14 bar). See Section 3.1B. Damage or injury may result if the monitor is operated beyond these limits.
- ⚠ CAUTION** On many vehicle installations, the monitor is the highest point on the apparatus. Be sure there is sufficient clearance to safely pass under any doors or overhead obstructions. Always check parked position of the monitor before moving.
- NOTICE** Use with salt water is permissible provided the monitor is thoroughly cleaned with fresh water after each use. The service life of the monitor may be shortened due to the effects of corrosion and is not covered under warranty.

## 3.0 GENERAL INFORMATION

The Task Force Tips HURRICANE Industrial Monitor based on our innovative and successful CROSSFIRE monitor is a very simple, yet effective, fixed location master stream device. It is made of ANSI A356.0-T6 aluminum that has been hardcoat anodized and then powder coated inside and out creating excellent corrosion resistance in the harshest environments.

The Task Force Tips HURRICANE RC is an electric remote monitor, with a single low-profile waterway discharge. It has high flow and low friction loss characteristics. See Operating Envelope for pressure and flow capabilities. Maintains a FULL 450° of rotational travel (225° either side of center position). Field changeable horizontal rotation stops at 45°, 90° and 135° either side of center position. Elevation range is 90° above horizontal and 45° below. Designed for auto sense 12 or 24 VDC operation. The Hurricane RC comes with a factory installed control panel mounted on the monitor for controlling horizontal rotation, elevation and nozzle pattern. See Task Force Tips Price List and Product Specifications for additional control stations. Unit comes with 30 feet of ultra-flexing robotic cable, enclosed in a unique wire guide, already wired to the monitor so installation effort is minimized. Knobs are provided on the horizontal rotation and elevation drive for manual override. TFT's Master Stream 1250 nozzle plugs into the factory installed nozzle power wire. All electrical components affecting water tightness are a minimum of NEMA 4 (IP65). Motors and control boxes are factory tested for water tightness. Available with various inlet adapters for flanges and thread fittings. Inlet also made for direct connection to TFT's Extend-A-Gun RC3 or RC4. Standard outlet is 2.5" National Hose male (65mm). Other outlets are available (see figure 3.3). A threaded port (0.25" NPT) (6.4mm) is provided for pressure gauge. The monitor is made from hardcoat anodized ANSI 356.0-T6 aluminum and silver powder coat finish inside and out.

### 3.1 MECHANICAL SPECIFICATIONS

|                           | Manual                                    |                      | Electric             |                      |
|---------------------------|---|----------------------|----------------------|----------------------|
|                           | US  | METRIC               | US                   | METRIC               |
| Weight                    | 23 lbs                                    | 10.4 kg              | 39 lbs               | 17.7 kg              |
| Min. Flow Area            | 7.07 in <sup>2</sup>                      | 45.6 cm <sup>2</sup> | 7.07 in <sup>2</sup> | 45.6 cm <sup>2</sup> |
| Max Flow                  | 1250 gpm                                  | 5000 l/min           | 1250 gpm             | 5000 l/min           |
| Max Operating Pressure    | 200 psi                                   | 14 bar               | 200 psi              | 14 bar               |
| Materials Used            | ANSI A356.0-T6 Aluminum, Stainless, Nylon |                      |                      |                      |
| Maximum Torque Elevation  |   |                      | 60 ft•lbs            | 80 n•m               |
| Maximum Torque Horizontal |   |                      | 60 ft•lbs            | 80 n•m               |
| Speed Elevation           | 9 deg/sec                                 |                      |                      |                      |
| Speed Horizontal          | 12 deg/sec                                |                      |                      |                      |

Fig 3.1A  
Specifications

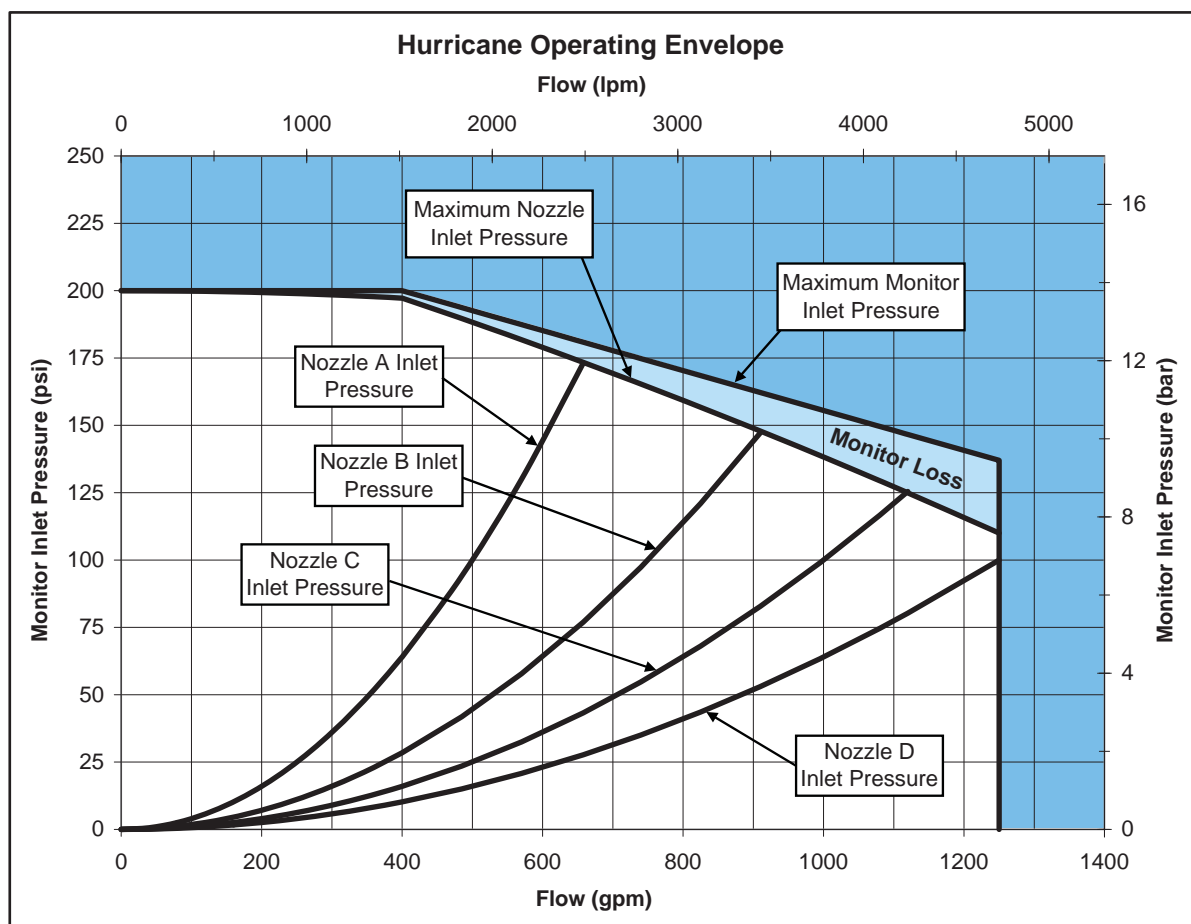

Nozzle A flows 500 gpm at 100 psi (7 bar), K factor = 50  
 Nozzle B flows 750 gpm at 100 psi (7 bar), K factor = 75  
 Nozzle C flows 1000 gpm at 100 psi (7 bar), K factor = 100  
 Nozzle D flows 1250 gpm at 100 psi (7 bar), K factor = 125

Fig 3.1B  
Operating Envelope

TFT HURRICANE FIXED MONITOR FRICTION LOSS

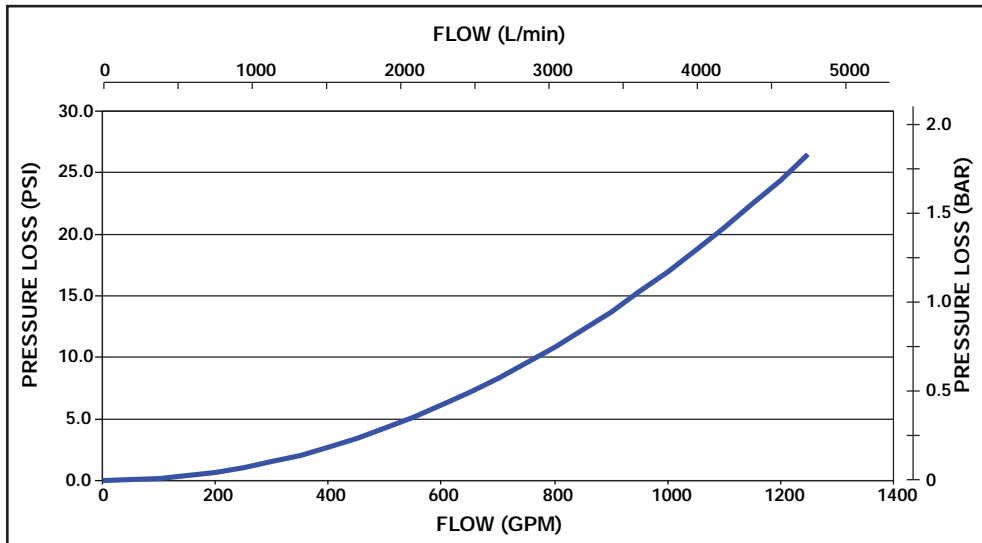

Fig 3.1C  
Friction Loss

3.2 PART IDENTIFICATION AND MODELS

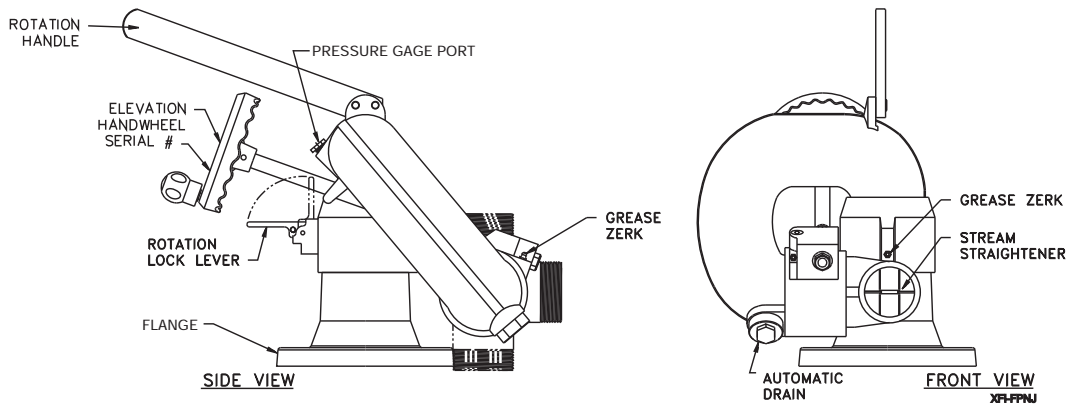

Fig. 3.2A  
Hurricane Monitor

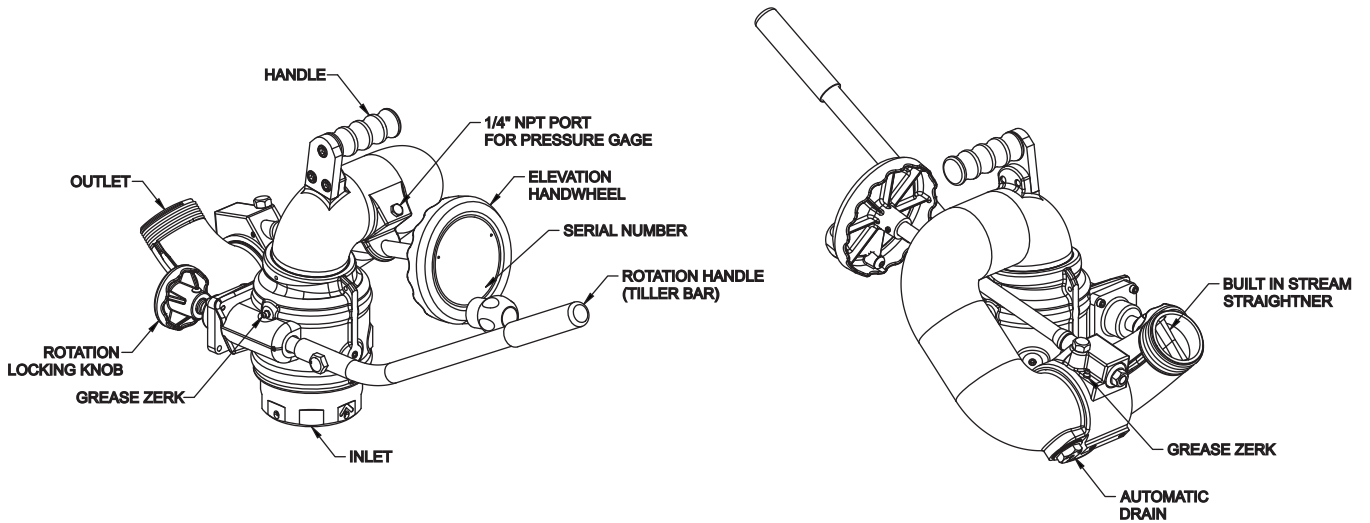

Fig. 3.2B  
Hurricane Tiller (XFIH-T series)

### 3.2 PART IDENTIFICATION AND MODELS

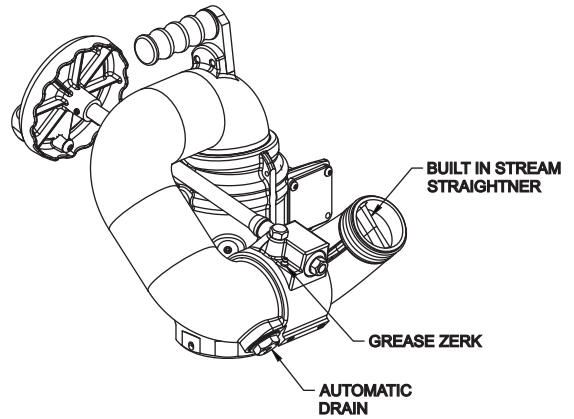
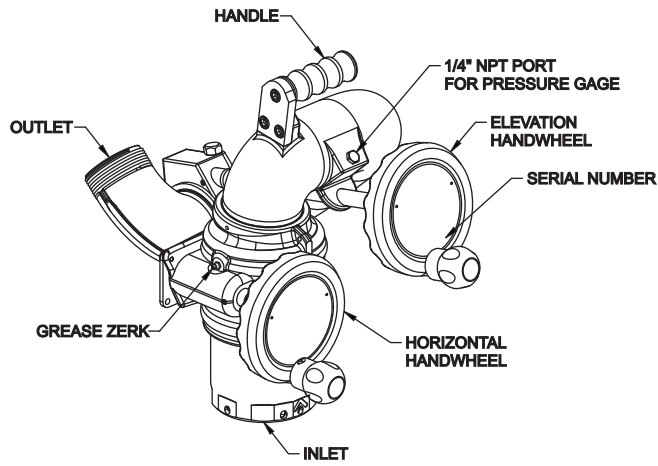

Fig. 3.2C  
Hurricane Dual Handwheel (XFIH-D series)

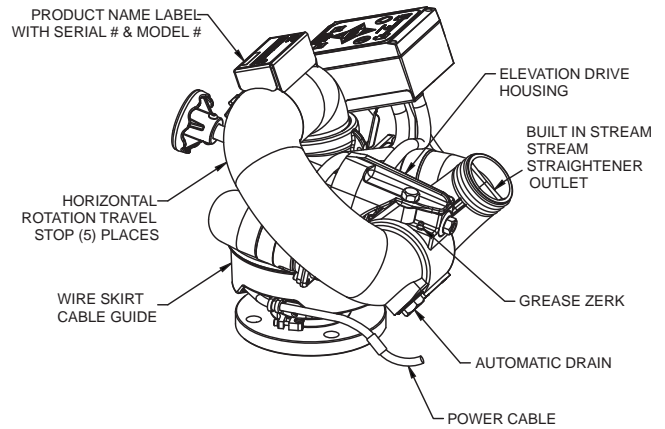
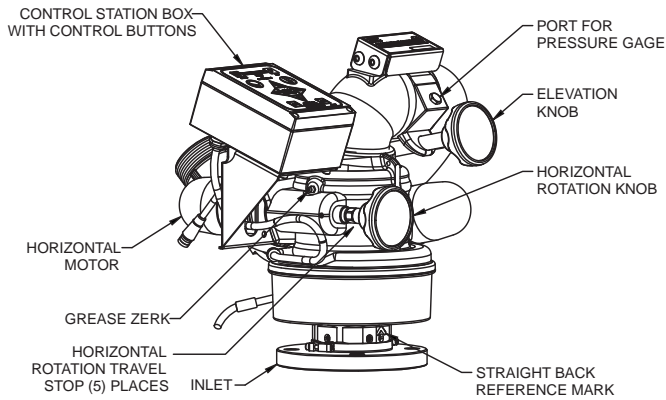

Fig. 3.2D  
Hurricane RC Monitor



### 3.3 INLETS AND OUTLETS

| MODEL     | INLET FITTING TYPE  | OUTSIDE DIAMETER   | THICKNESS    | BOLT HOLE CIRCLES  | NO. BOLT HOLES | SIZE OF BOLTS | TORQUE ON BOLTS                       |    |    |    |    |    |           |                  |                |    |    |    |    |    |           |  |                  |    |    |    |    |    |           |  |                    |    |    |    |    |    |           |  |               |              |                         |        |             |                              |           |   |                  |    |    |    |    |    |           |   |                |    |    |    |    |    |           |   |                  |    |    |    |    |    |
|-----------|---|--------------------|--------------|--|----------------|---------------|---------------------------------------|----|----|----|----|----|-----------|------------------|----------------|----|----|----|----|----|-----------|--|------------------|----|----|----|----|----|-----------|--|--------------------|----|----|----|----|----|-----------|--|---------------|--------------|-------------------------|--------|-------------|------------------------------|-----------|---|------------------|----|----|----|----|----|-----------|---|----------------|----|----|----|----|----|-----------|---|------------------|----|----|----|----|----|
| XFI-FL*   | 3" ANSI 150<br>(metric DN80 PN20)                         | 7.5"<br>190mm      | .75"<br>20mm | 6.0"<br>152.5mm  | 4<br>4         | 5/8"<br>M16   | 76-80 FT-LBF<br>100-110 Newton Meters |    |    |    |    |    |           |                  |                |    |    |    |    |    |           |  |                  |    |    |    |    |    |           |  |                    |    |    |    |    |    |           |  |               |              |                         |        |             |                              |           |   |                  |    |    |    |    |    |           |   |                |    |    |    |    |    |           |   |                  |    |    |    |    |    |
| XFI-FP*   | 4" ANSI 150<br>(metric DN100 PN20)                        | 9.0"<br>230mm      | .94"<br>23mm | 7.5"<br>190.2mm  | 8<br>8         | 5/8"<br>M16   | 76-80 FT-LBF<br>100-110 Newton Meters |    |    |    |    |    |           |                  |                |    |    |    |    |    |           |  |                  |    |    |    |    |    |           |  |                    |    |    |    |    |    |           |  |               |              |                         |        |             |                              |           |   |                  |    |    |    |    |    |           |   |                |    |    |    |    |    |           |   |                  |    |    |    |    |    |
| XFIH-E1*A | 3" ANSI 125/150<br>(metric DN80 PN20)                     | 7.5"<br>190mm      | .75"<br>20mm | 6.0"<br>152.5mm  | 4<br>4         | 5/8"<br>M16   | 76-80 FT-LBF<br>100-110 Newton Meters |    |    |    |    |    |           |                  |                |    |    |    |    |    |           |  |                  |    |    |    |    |    |           |  |                    |    |    |    |    |    |           |  |               |              |                         |        |             |                              |           |   |                  |    |    |    |    |    |           |   |                |    |    |    |    |    |           |   |                  |    |    |    |    |    |
| XFIH-E2*A | 4" ANSI 150<br>(metric DN100 PN20)                        | 9.0"<br>230mm      | .94"<br>23mm | 7.5"<br>190.2mm  | 8<br>8         | 5/8"<br>M16   | 76-80 FT-LBF<br>100-110 Newton Meters |    |    |    |    |    |           |                  |                |    |    |    |    |    |           |  |                  |    |    |    |    |    |           |  |                    |    |    |    |    |    |           |  |               |              |                         |        |             |                              |           |   |                  |    |    |    |    |    |           |   |                |    |    |    |    |    |           |   |                  |    |    |    |    |    |
| XFIH-E4*A | metric DN80, PN16   | 200 mm             | 22 mm        | 160 mm   | 8              | 16 mm         | 100-110 Newton Meters                 |    |    |    |    |    |           |                  |                |    |    |    |    |    |           |  |                  |    |    |    |    |    |           |  |                    |    |    |    |    |    |           |  |               |              |                         |        |             |                              |           |   |                  |    |    |    |    |    |           |   |                |    |    |    |    |    |           |   |                  |    |    |    |    |    |
| XFIH-E5*A | metric DN100, PN16  | 220mm              | 22 mm        | 180 mm   | 8              | 16 mm         | 100-110 Newton Meters                 |    |    |    |    |    |           |                  |                |    |    |    |    |    |           |  |                  |    |    |    |    |    |           |  |                    |    |    |    |    |    |           |  |               |              |                         |        |             |                              |           |   |                  |    |    |    |    |    |           |   |                |    |    |    |    |    |           |   |                  |    |    |    |    |    |
| XFIH-*6*A | 3" NPT Female   | 4.40" (111.8mm)    | NA           | NA   | NA             | NA            | NA                                    |    |    |    |    |    |           |                  |                |    |    |    |    |    |           |  |                  |    |    |    |    |    |           |  |                    |    |    |    |    |    |           |  |               |              |                         |        |             |                              |           |   |                  |    |    |    |    |    |           |   |                |    |    |    |    |    |           |   |                  |    |    |    |    |    |
| XFIH-*7*A | 4" NPT Female   | 5.40" (137.2mm)    | NA           | NA   | NA             | NA            | NA                                    |    |    |    |    |    |           |                  |                |    |    |    |    |    |           |  |                  |    |    |    |    |    |           |  |                    |    |    |    |    |    |           |  |               |              |                         |        |             |                              |           |   |                  |    |    |    |    |    |           |   |                |    |    |    |    |    |           |   |                  |    |    |    |    |    |
| XFIH-*8*A | 3" BSP Male   | 4.40" (111.8mm)    | NA           | NA </tr <tr> <td>XFIH-*9*A</td> <td>4" BSP Male</td> <td>5.40" (137.2mm)</td> <td>NA</td> <td>NA</td> <td>NA</td> <td>NA</td> <td>NA</td> </tr> <tr> <td>XFIH-*L*A</td> <td>Extend-A-Gun RC3</td> <td>3.94" (94.6mm)</td> <td>NA</td> <td>NA</td> <td>NA</td> <td>NA</td> <td>NA</td> </tr> <tr> <td>XFIH-*P*A</td> <td>"Extend-A-Gun RC4 or<br/>Valve Under Monitor"</td> <td>4.94"<br/>123.5mm</td> <td>NA</td> <td>NA</td> <td>NA</td> <td>NA</td> <td>NA</td> </tr> <tr> <td>XFIH-*Q*A</td> <td>"4.5"" Quick Connect<br/>(without inlet adapter)"</td> <td>6.75"<br/>(171.5mm)</td> <td>NA</td> <td>NA</td> <td>NA</td> <td>NA</td> <td>NA</td> </tr> <tr> <td>XFIH-*R*A</td> <td>"4.5"" Quick Connect with<br/>4""ANSI 150/DN100 PN16"</td> <td>9.0"<br/>230mm</td> <td>.94"<br/>23mm</td> <td>7.5 / 7.09<br/>190/180mm</td> <td>8<br/>8</td> <td>5/8<br/>16mm</td> <td>76-80 ft-lbf<br/>(100-110 Nm)</td> </tr> <tr> <td>XFIH-*S*A</td> <td>"4.5"" Quick Connect with<br/>4""NPT female inlet adapter"</td> <td>5.40"<br/>137.2mm</td> <td>NA</td> <td>NA</td> <td>NA</td> <td>NA</td> <td>NA</td> </tr> <tr> <td>XFIH-*T*A</td> <td>"4.5"" Quick Connect for<br/>Extend-A-Gun RC3"</td> <td>4.25"<br/>108mm</td> <td>NA</td> <td>NA</td> <td>NA</td> <td>NA</td> <td>NA</td> </tr> <tr> <td>XFIH-*U*A</td> <td>"4.5"" Quick Connect for<br/>Extend-A-Gun RC4"</td> <td>5.36"<br/>136.1mm</td> <td>NA</td> <td>NA</td> <td>NA</td> <td>NA</td> <td>NA</td> </tr> | XFIH-*9*A      | 4" BSP Male   | 5.40" (137.2mm)                       | NA | NA | NA | NA | NA | XFIH-*L*A | Extend-A-Gun RC3 | 3.94" (94.6mm) | NA | NA | NA | NA | NA | XFIH-*P*A | "Extend-A-Gun RC4 or<br>Valve Under Monitor" | 4.94"<br>123.5mm | NA | NA | NA | NA | NA | XFIH-*Q*A | "4.5"" Quick Connect<br>(without inlet adapter)" | 6.75"<br>(171.5mm) | NA | NA | NA | NA | NA | XFIH-*R*A | "4.5"" Quick Connect with<br>4""ANSI 150/DN100 PN16" | 9.0"<br>230mm | .94"<br>23mm | 7.5 / 7.09<br>190/180mm | 8<br>8 | 5/8<br>16mm | 76-80 ft-lbf<br>(100-110 Nm) | XFIH-*S*A | "4.5"" Quick Connect with<br>4""NPT female inlet adapter" | 5.40"<br>137.2mm | NA | NA | NA | NA | NA | XFIH-*T*A | "4.5"" Quick Connect for<br>Extend-A-Gun RC3" | 4.25"<br>108mm | NA | NA | NA | NA | NA | XFIH-*U*A | "4.5"" Quick Connect for<br>Extend-A-Gun RC4" | 5.36"<br>136.1mm | NA | NA | NA | NA | NA |
| XFIH-*9*A | 4" BSP Male   | 5.40" (137.2mm)    | NA           | NA   | NA             | NA            | NA                                    |    |    |    |    |    |           |                  |                |    |    |    |    |    |           |  |                  |    |    |    |    |    |           |  |                    |    |    |    |    |    |           |  |               |              |                         |        |             |                              |           |   |                  |    |    |    |    |    |           |   |                |    |    |    |    |    |           |   |                  |    |    |    |    |    |
| XFIH-*L*A | Extend-A-Gun RC3  | 3.94" (94.6mm)     | NA           | NA   | NA             | NA            | NA                                    |    |    |    |    |    |           |                  |                |    |    |    |    |    |           |  |                  |    |    |    |    |    |           |  |                    |    |    |    |    |    |           |  |               |              |                         |        |             |                              |           |   |                  |    |    |    |    |    |           |   |                |    |    |    |    |    |           |   |                  |    |    |    |    |    |
| XFIH-*P*A | "Extend-A-Gun RC4 or<br>Valve Under Monitor"              | 4.94"<br>123.5mm   | NA           | NA   | NA             | NA            | NA                                    |    |    |    |    |    |           |                  |                |    |    |    |    |    |           |  |                  |    |    |    |    |    |           |  |                    |    |    |    |    |    |           |  |               |              |                         |        |             |                              |           |   |                  |    |    |    |    |    |           |   |                |    |    |    |    |    |           |   |                  |    |    |    |    |    |
| XFIH-*Q*A | "4.5"" Quick Connect<br>(without inlet adapter)"          | 6.75"<br>(171.5mm) | NA           | NA   | NA             | NA            | NA                                    |    |    |    |    |    |           |                  |                |    |    |    |    |    |           |  |                  |    |    |    |    |    |           |  |                    |    |    |    |    |    |           |  |               |              |                         |        |             |                              |           |   |                  |    |    |    |    |    |           |   |                |    |    |    |    |    |           |   |                  |    |    |    |    |    |
| XFIH-*R*A | "4.5"" Quick Connect with<br>4""ANSI 150/DN100 PN16"      | 9.0"<br>230mm      | .94"<br>23mm | 7.5 / 7.09<br>190/180mm  | 8<br>8         | 5/8<br>16mm   | 76-80 ft-lbf<br>(100-110 Nm)          |    |    |    |    |    |           |                  |                |    |    |    |    |    |           |  |                  |    |    |    |    |    |           |  |                    |    |    |    |    |    |           |  |               |              |                         |        |             |                              |           |   |                  |    |    |    |    |    |           |   |                |    |    |    |    |    |           |   |                  |    |    |    |    |    |
| XFIH-*S*A | "4.5"" Quick Connect with<br>4""NPT female inlet adapter" | 5.40"<br>137.2mm   | NA           | NA   | NA             | NA            | NA                                    |    |    |    |    |    |           |                  |                |    |    |    |    |    |           |  |                  |    |    |    |    |    |           |  |                    |    |    |    |    |    |           |  |               |              |                         |        |             |                              |           |   |                  |    |    |    |    |    |           |   |                |    |    |    |    |    |           |   |                  |    |    |    |    |    |
| XFIH-*T*A | "4.5"" Quick Connect for<br>Extend-A-Gun RC3"             | 4.25"<br>108mm     | NA           | NA   | NA             | NA            | NA                                    |    |    |    |    |    |           |                  |                |    |    |    |    |    |           |  |                  |    |    |    |    |    |           |  |                    |    |    |    |    |    |           |  |               |              |                         |        |             |                              |           |   |                  |    |    |    |    |    |           |   |                |    |    |    |    |    |           |   |                  |    |    |    |    |    |
| XFIH-*U*A | "4.5"" Quick Connect for<br>Extend-A-Gun RC4"             | 5.36"<br>136.1mm   | NA           | NA   | NA             | NA            | NA                                    |    |    |    |    |    |           |                  |                |    |    |    |    |    |           |  |                  |    |    |    |    |    |           |  |                    |    |    |    |    |    |           |  |               |              |                         |        |             |                              |           |   |                  |    |    |    |    |    |           |   |                |    |    |    |    |    |           |   |                  |    |    |    |    |    |

\* These digits in the model number refer to exit thread size and type.

Fig 3.3A  
Inlet Flange Size Specifications

The standard Hurricane RC Monitor inlet is CODE-RLF for direct connection to TFT's Extend-A-Gun RC3. Monitor inlet CODE-RPF is available for direct connection to Extend-A-Gun RC4. The standard outlet is 2.5"-7.5 National Hose male. Various other inlet and outlet fittings are available as shown in Figure 3.3B.

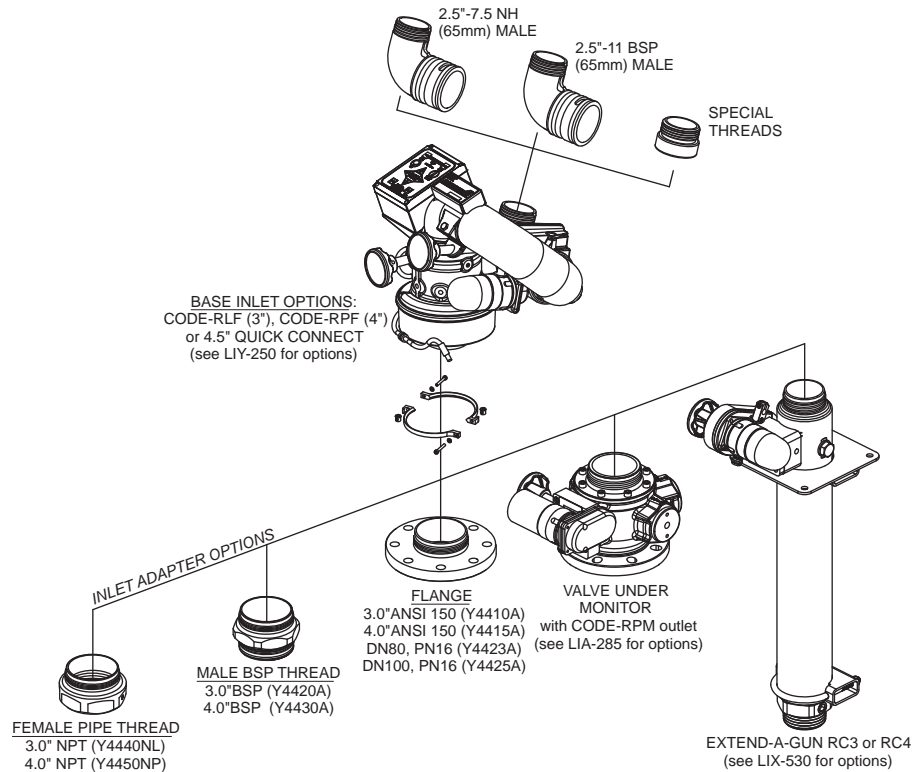
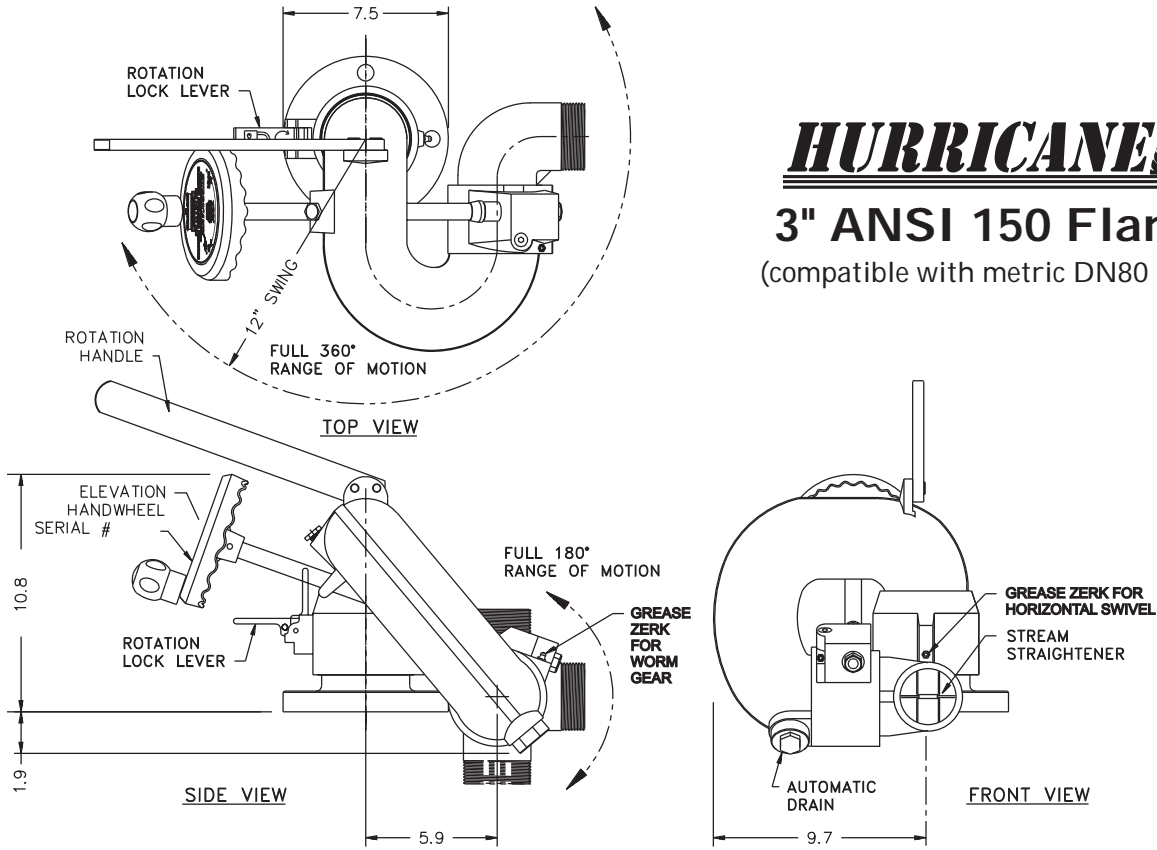

Fig 3.3B  
Inlets and Outlets

### 3.4 OVERALL DIMENSIONS



**HURRICANE**

**3" ANSI 150 Flange**  
(compatible with metric DN80 PN20)

Fig 3.4A  
Hurricane Fixed Monitor Overall Dimensions  
w/3" ANSI 150 Flange

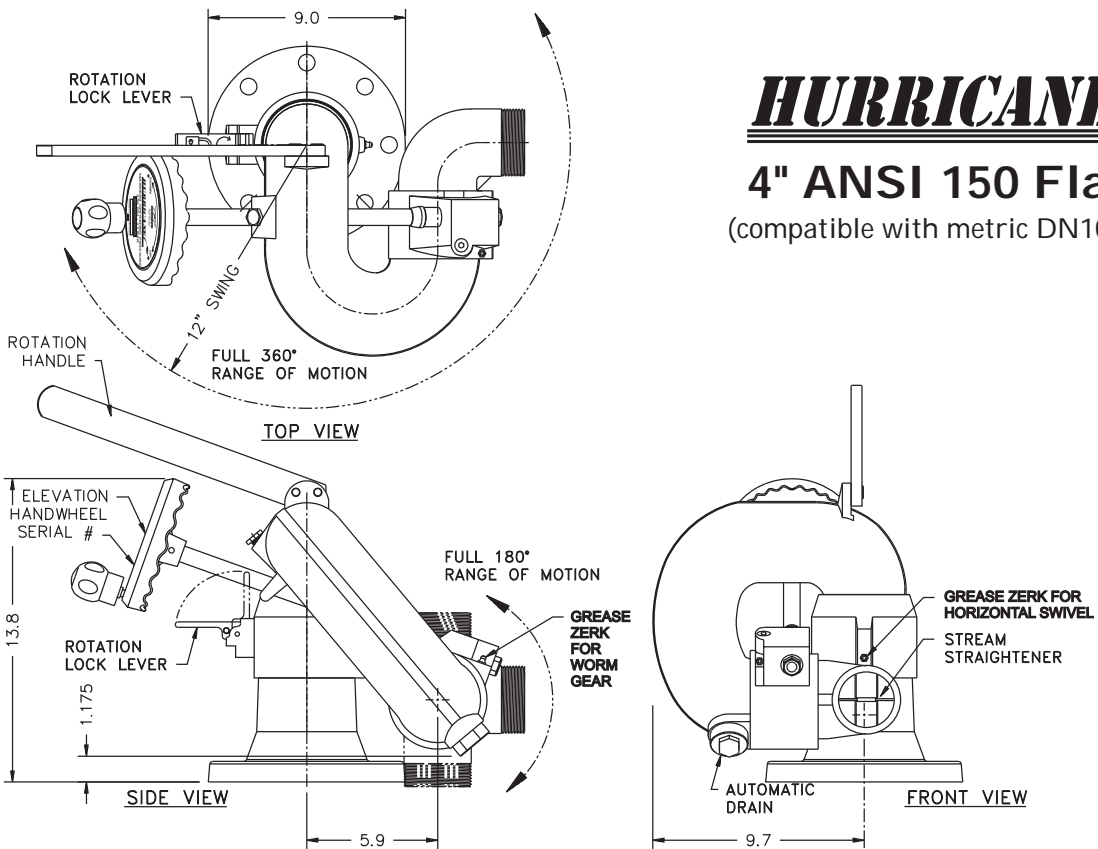

**HURRICANE**

**4" ANSI 150 Flange**  
(compatible with metric DN100 PN20)

Fig 3.4B  
Hurricane Fixed Monitor Overall Dimensions  
w/4" ANSI 150 Flange



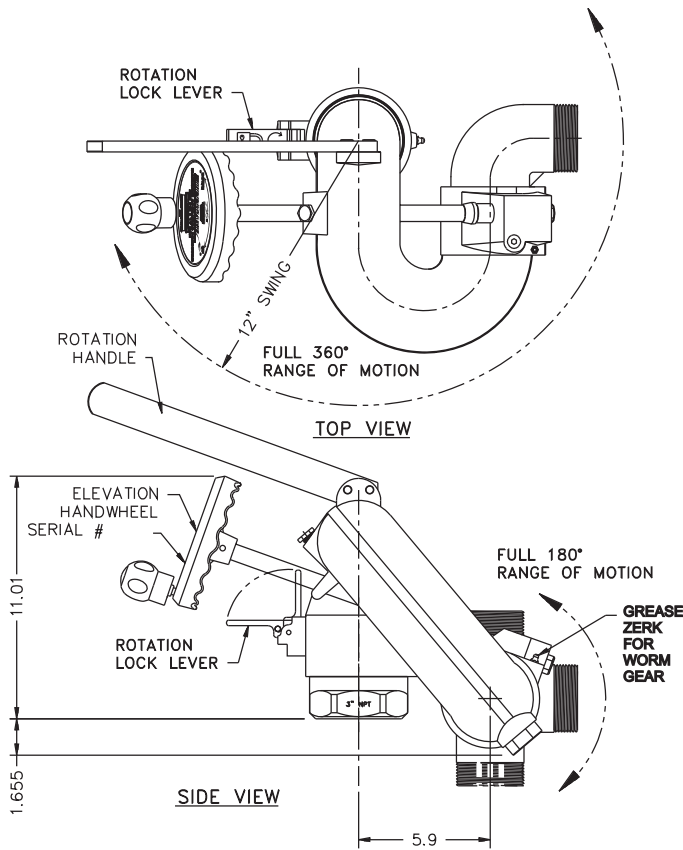

**AV**

## 3" NPT Female Inlet

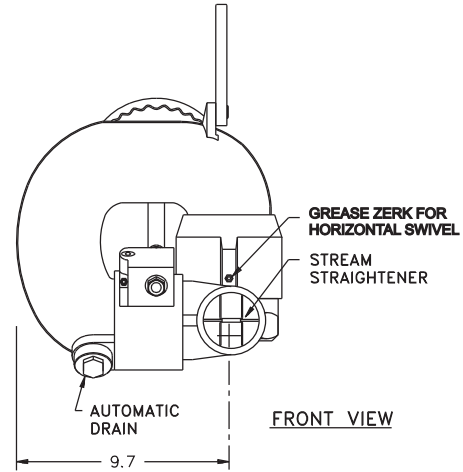
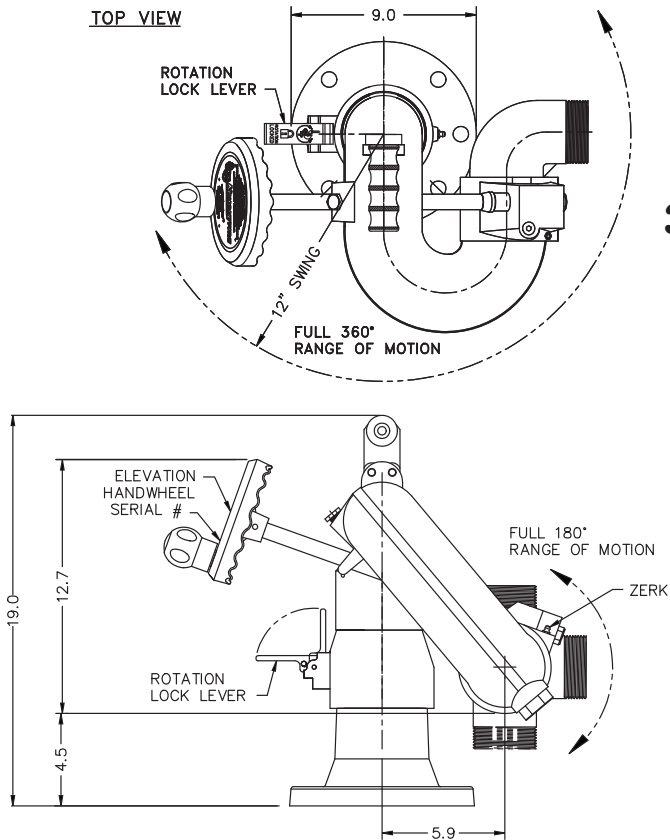

Fig 3.4C  
Hurricane Fixed Monitor Overall Dimensions  
w/3" NPT Female Inlet



**AV**

## 3" or 4" ANSI 150 Flange Extended Monitor

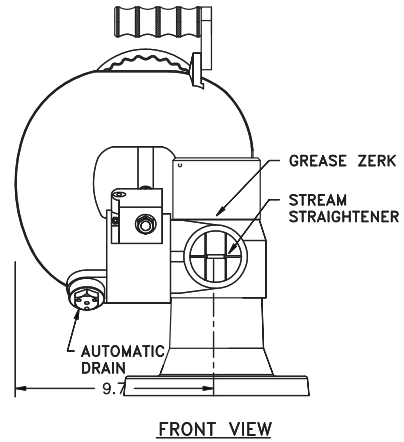
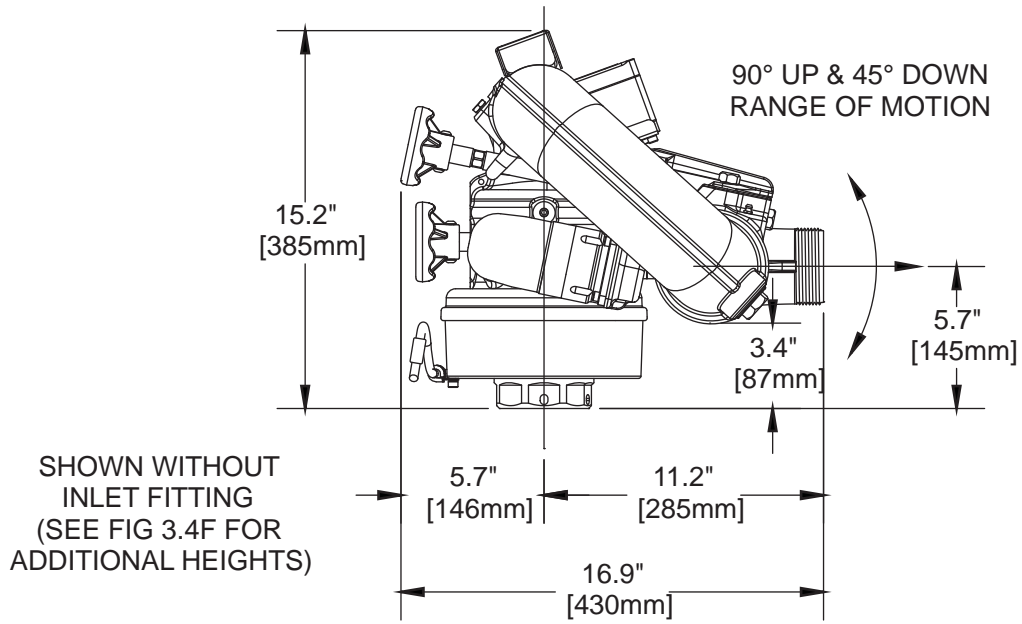

Fig 3.4D  
Hurricane Fixed Extended Monitor Overall Dimensions  
w/3" or 4" ANSI 150 Flange



**HURRICANE RC**

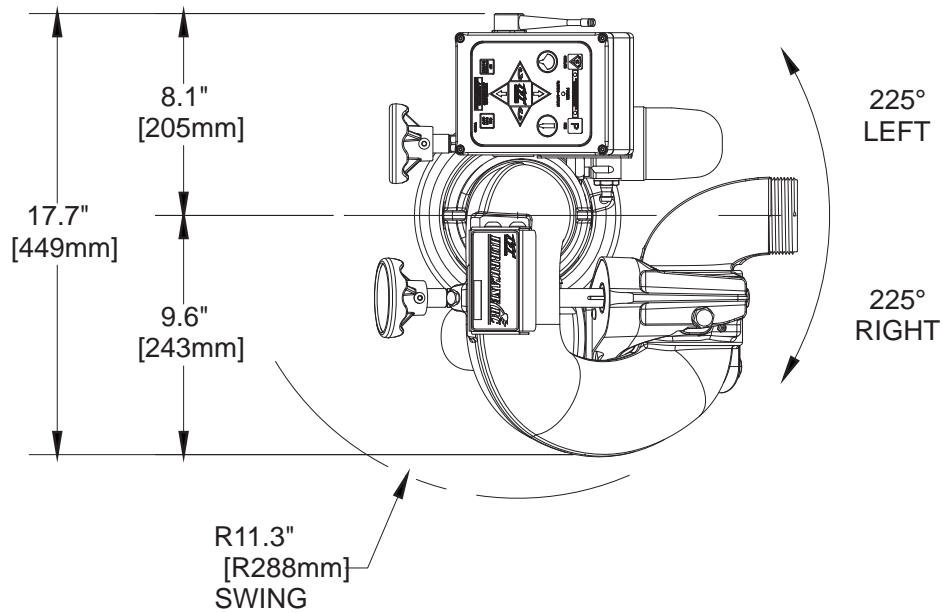

Fig 3.4E  
Hurricane RC Overall Dimensions

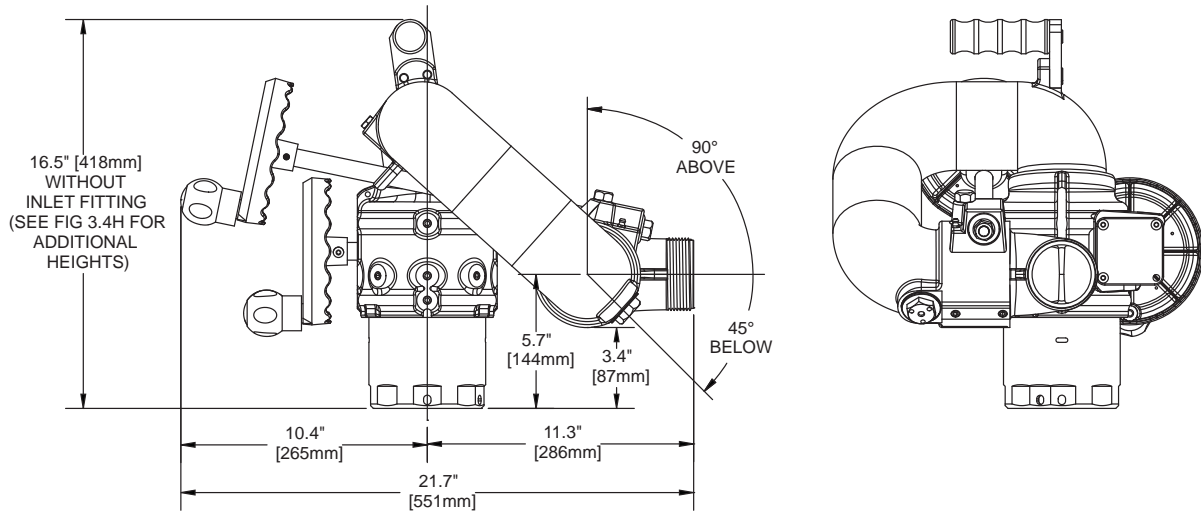
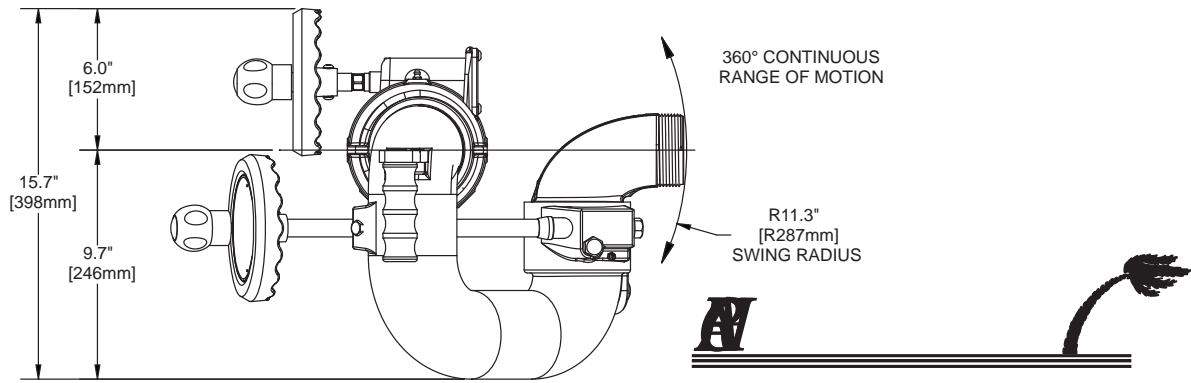

Fig 3.4F  
Hurricane Dual Handwheel Overall Dimensions  
(XFIH-D series)

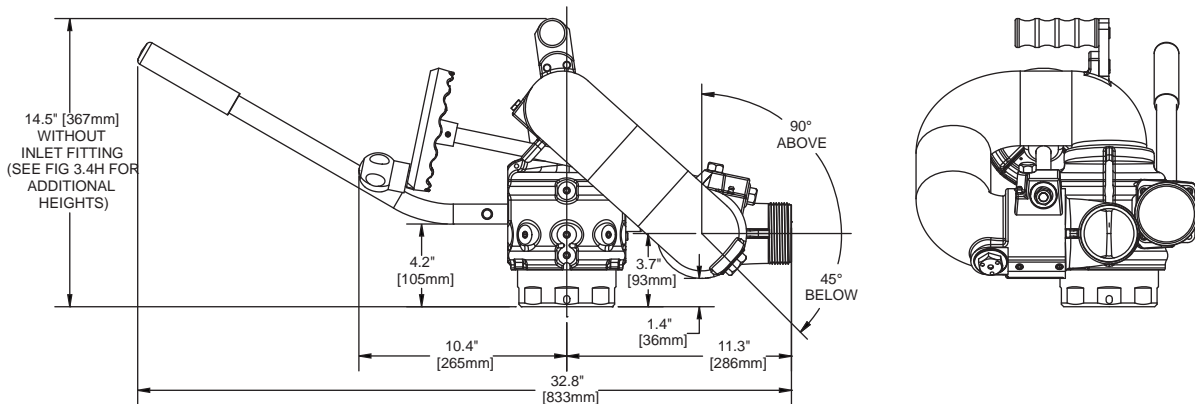
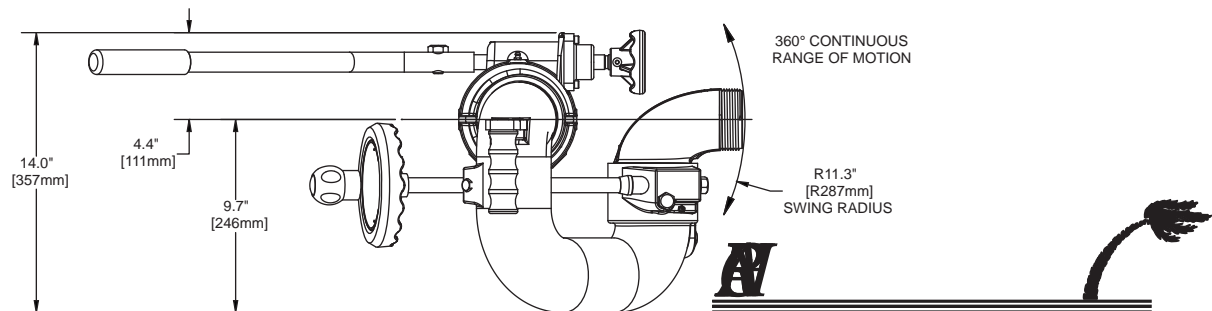

Fig 3.4G  
Hurricane Tiller Overall Dimensions  
(XFIH-T series)

| MODEL                  | INLET FITTING TYPE                    | ADDITIONAL HEIGHT               |
|------------------------|---------------------------------------|---------------------------------|
| XFIH-*1*A              | 3" ANSI 125/150<br>(metric DN80 PN20) | .75" (20mm)                     |
| XFIH-*2*A              | 4" ANSI 150<br>(metric DN100 PN20)    | .94" (23mm)                     |
| XFIH-*4*A              | metric DN80, PN16                     | 2.80" (22mm)                    |
| XFIH-*5*A              | metric DN100, PN16                    | 2.80" (22mm)                    |
| XFIH-*6*A              | 3" NPT Female                         | 2.00" (51mm)                    |
| XFIH-*7*A              | 4" NPT Female                         | 1.75" (45mm)                    |
| XFIH-*8*A              | 3" BSP Male                           | 2.30" (58mm)                    |
| XFIH-*9*A              | 4" BSP Male                           | 2.30" (58mm)                    |
| XFIH-DQ*A<br>XFIH-EQ*A | 4.5" Quick Connect                    | 0.63" (16mm) + inlet adapter ** |
| XFIH-TQ*A              | 4.5" Quick Connect                    | 3.38" (86mm) + inlet adapter ** |

\* These digits in the model number refer to control type and to exit thread type.

\*\* Use height from inlet adapter drawings (YQC series) to determine overall height of monitor with Quick Connect.

Fig 3.4H  
Overall Height increase for inlet fittings on  
Hurricane RC (XFIH-E), Dual Handwheel (XFIH-D) and Tiller (XFIH-T)

## 4.0 INSTALLATION

See LIY-500 Remote Control (RC) Monitor Electrical Controls Supplemental Instructions for use with Hurricane RC Models. See LIY-250 Quick Connect Supplemental Instructions for installation of Quick Connect Inlet Adapters.

### 4.1 STRUCTURAL REQUIREMENTS FOR MONITOR MOUNTING

The structure that the Hurricane Monitor is mounted to must withstand the internal pressure of the monitor as well as shear and bending forces due to nozzle reaction. Nozzle reaction can be as high as 940 lbs (430 kg).

For flanged connections, the use of flat flanges without raised faces is recommended. Use a ring gasket as defined in ASME 16.21 or ISO 7483. Tighten flange bolts in an alternating sequence as shown in figure 4.1. Tighten to 76-80 ft-lb (100-110 Newton-Meters).

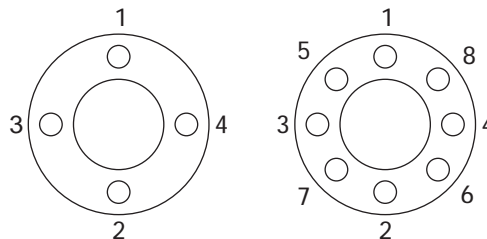

Fig 4.1 Flange Bolt Tightening Sequence



**WARNING** Injury can result from an inadequately supported monitor. The monitor mount must be capable of supporting the nozzle reaction force which can be as high as 940 lbs (430 kg). Flanges and pipe made from plastic are inadequate for monitor mounting and must not be used. This monitor is not recommended for portable use.

#### 4.1.1 WATER SUPPLY

The HURRICANE Monitor is mounted on a riser pipe by a bolted flange joint. Make sure that the area around the monitor is free from obstructions which would limit its range of motion and usefulness. If a valve is mounted under the HURRICANE, make sure the monitor will not interfere with the valve handle. If a butterfly valve is mounted under the monitor make sure that the butterfly valve assembly does not interfere with the flanged base of the HURRICANE.

### 4.2 INLET MOUNTING AND TRAVEL RANGES

#### 4.2.1 INLET FITTING OR EXTEND-A-GUN RC INSTALLATION

The Hurricane RC Monitor is available with various inlet fittings as shown in figure 3.3B. The Hurricane RC Monitor also connects directly to TFT's Extend-A-Gun RC3 or RC4. The fittings and Extend-A-Gun RC are attached to the monitor by means of a threaded joint with an o-ring seal. Install the monitor using the following procedures.

**TWO PIECE CLAMP ROTATIONAL LOCK INSTALLATION INSTRUCTIONS:**

- 1) Assemble Clamps and place loosely on Inlet Adapter or Extend-A-Gun.
  - A) Apply VSA-125 blue Loctite to threads on Cylinder Nut.
  - B) Loosely install Screws, Washers and Cylinder Nuts on Clamp.
  - C) Grooves on heads of Cylinder Nuts indicate alignment of threaded holes.
  - D) Place Clamp assembly over male threads of outlet.
  - E) Heads of Cylinder Nuts must be on top side of Clamps.
- 2) Screw monitor onto Inlet Adapter or Extend-A-Gun RC until threaded joint bottoms out.
  - A) **MAKE SURE THE CLAMPS ARE NOT TIGHT ENOUGH TO PREVENT THE MONITOR BASE FROM BOTTOMING OUT.** The monitor will leak if it does not bottom out in this step.
  - B) **DO NOT USE PIPE SEALANT OR LOCTITE ON THE INLET BASE THREADS.** These threads are sealed with an O-ring. The use of thread locking compounds will make removal difficult.
- 3) Unscrew monitor until the "Straight Back Reference Mark" is facing the desired direction.
  - A) Monitor may be unscrewed up to one full turn from the bottomed out position.
  - B) **MONITOR WILL LEAK IF UNTHREADED MORE THAN ONE FULL ROTATION FROM BOTTOMED-OUT CONDITION.**
- 4) Rotate the Clamps to the desired orientation.
  - A) Ensure that Clamp assembly does not interfere with RC monitor Power/Com Cable.
- 4) Tighten each Screw gradually until both are finger tight with approximately equal spacing between opposite ends of Clamps.
- 5) Carefully tighten each Screw one additional turn using a 5/32 hex wrench by alternating to the opposite Screw in half turn increments.
  - A) **OVER TIGHTENING THE SCREWS WILL DAMAGE SCREWS AND CLAMPS.**

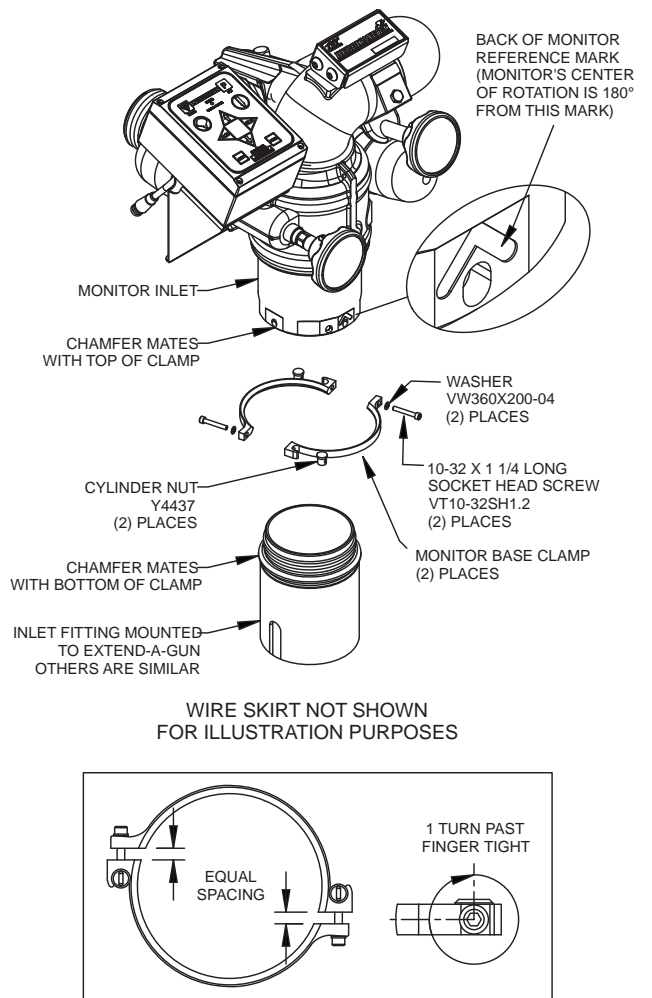
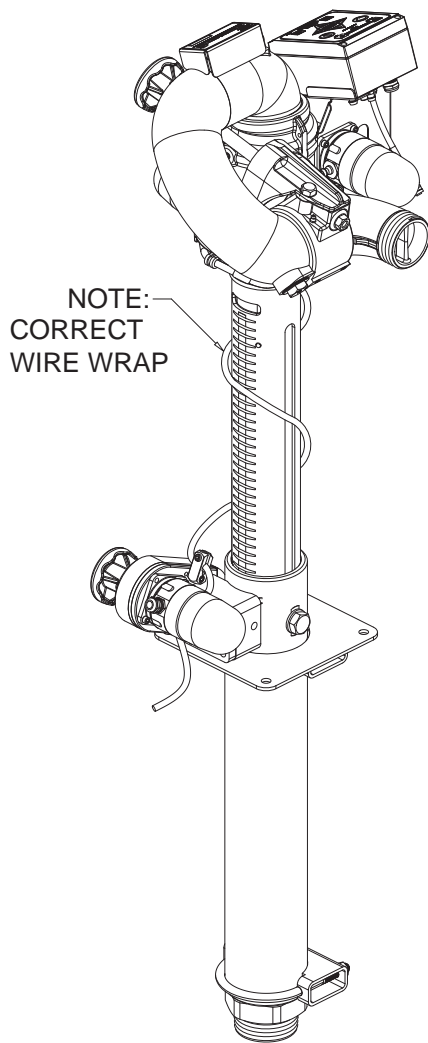
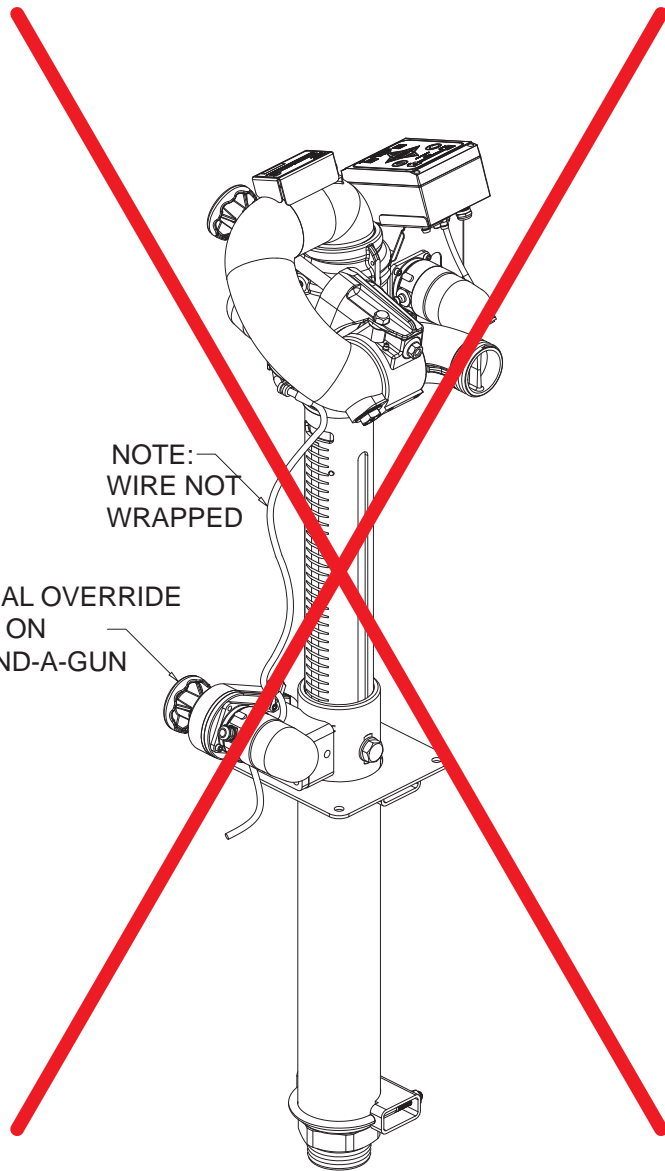

Fig 4.2.1A



CORRECT WIRE WRAP



NOT CORRECT

Fig 4.2.1B Extend-A-Gun RC Mounting

The Extend-A-Gun manual override knob may be mounted in any of four possible orientations (90 degrees apart) relative to the Straight Back Reference Mark on the monitor.

NOTE: Hurricane RC monitor, for use with Extend-A-Gun RC, comes with the wire installed in a nylon tube. The nylon tubing gives the wire additional stiffness so it better follows as the Extend-A-Gun RC extends or retracts. A fitting is also supplied and is to be used where the nylon tubing and wire pass through the deck.



## 4.2.2 HORIZONTAL ROTATION TRAVEL STOPS

The range of Horizontal (left-right) travel for the Hurricane RC monitor is limited to 450 degrees or 225 degrees from either side of "Straight Back Reference Mark". Horizontal (left-right) travel stop bolts may be installed in the monitor to limit travel as shown in figure 4.2.2A and 4.2.2B. Note that left and right are relative to the "Straight Back Reference Mark" shown in figure 4.2.2A, and refer to the operator's position behind the monitor, opposite the nozzle's discharge direction. Also, Figure 4.2.2A shows the range of travel for the various stop bolt locations along with installation notes as shown in Figure 4.2.2B. Horizontal travel for the Hurricane is shown in figure 4.2.2C.

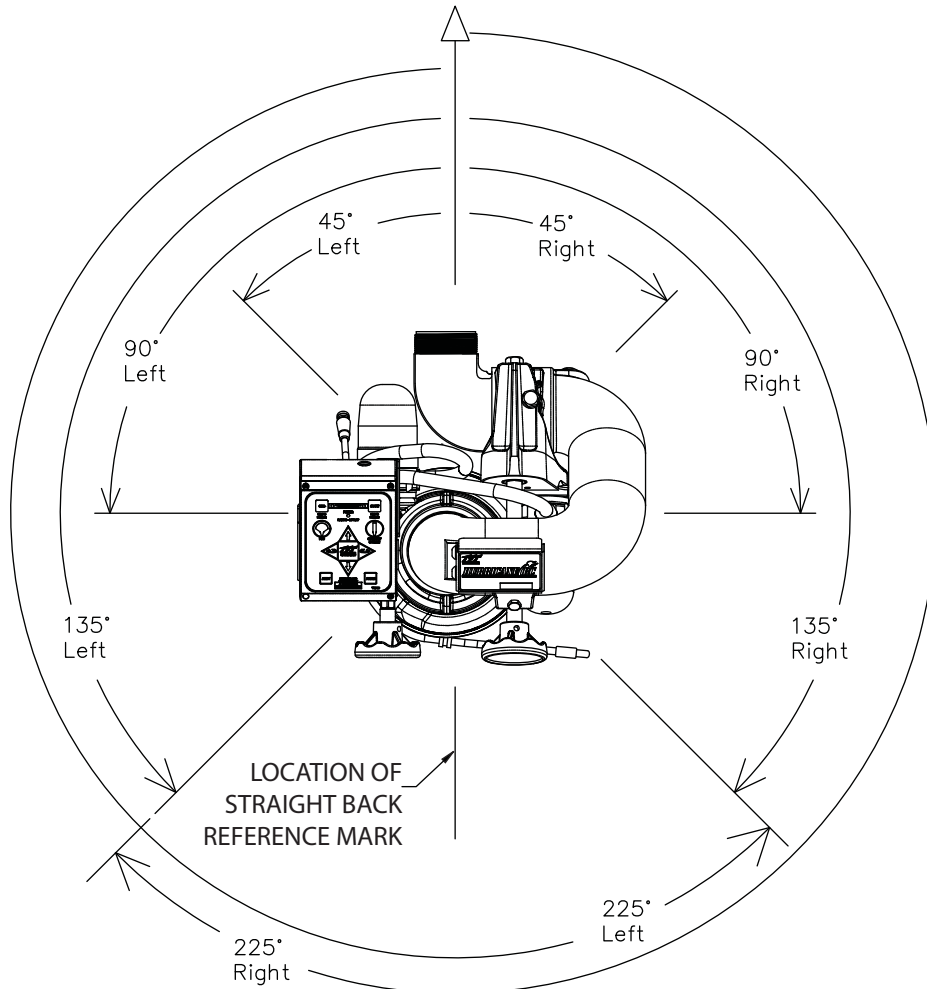

Fig 4.2.2A  
Horizontal Travel Limits

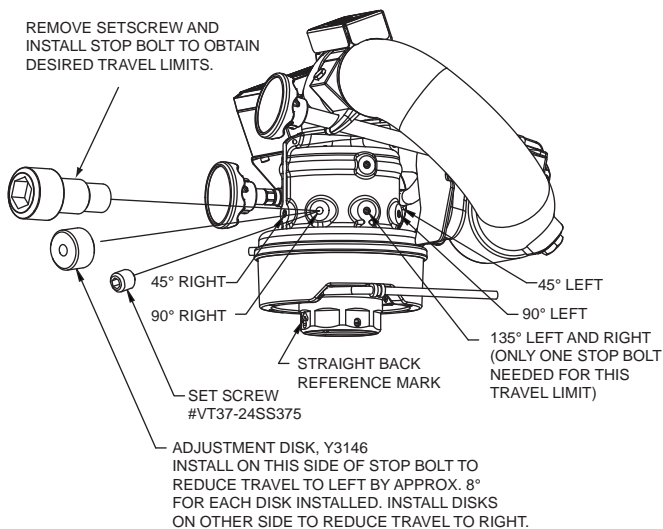

Fig 4.2.2B  
Horizontal Travel Stop Bolt Locations

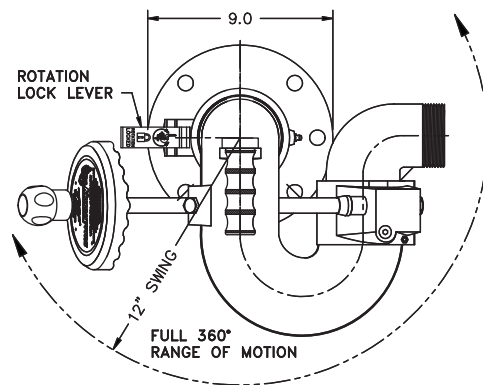

Fig 4.2.2C  
Hurricane Horizontal Travel

### 4.2.3 VERTICAL ROTATION TRAVEL STOPS

The range of elevation travel for the Hurricane RC monitor is shown in Fig. 4.2.3A. The elevation range of travel may be reduced by installing Adjustment Disks as shown in Fig. 4.2.3B. The range of elevation travel for the Hurricane monitor is shown in Fig 4.2.3C.

Install On This Side Of Stop Bolt To Reduce Downward Travel By Approx 10° For Each Disk Installed. Install Disks On Other Side To Reduce Upward Travel.

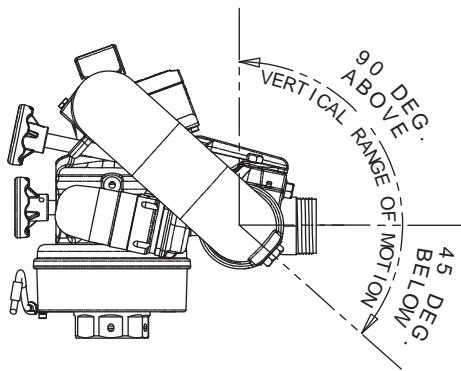

Fig 4.2.3A  
Hurricane RC Vertical Travel

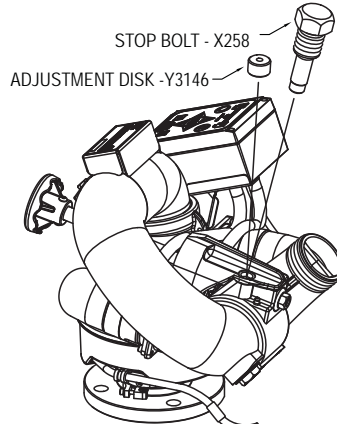

Fig 4.2.3B

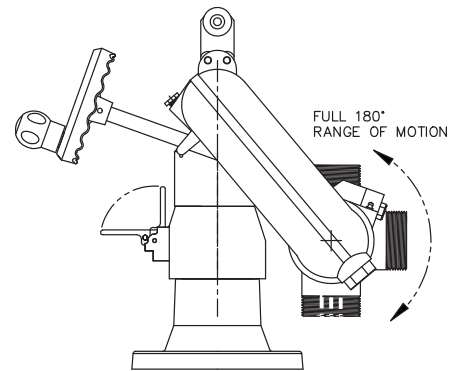

Fig 4.2.3C  
Hurricane Vertical Travel

### 4.3 NOZZLE INSTALLATION

The Hurricane Fixed Monitor is available with 2.5" male NH or BSP threads to attach the nozzle. Simply screw the nozzle onto the monitors exit threads.

The Hurricane RC monitor outlet thread types are as shown in figure 3.3B. Insure that the nozzle's coupling does not make contact with the elevation drive housing when the monitor is in its highest elevation position.

For nozzles with electric pattern control, a waterproof connector wire is provided at the bottom outlet of the Hurricane RC's control station box. This wire attaches directly to TFT's electric Masterstream 1250 nozzle. The electric actuator box of nozzle must be oriented to the top side of nozzle for the connection wire to extend 90° above horizontal and 45° below elevation movement. (see figure 4.3 and refer to *RC Monitor Electrical Controls Supplemental Instructions (LIY-500)* for properly attaching female to male connectors). Any other nozzle should have the corresponding male electrical connector installed and long enough wire to extend 90° above horizontal and 45° below elevation movement of the nozzle. **DO NOT CUT OFF THE FEMALE CONNECTOR ON THE MONITOR. THIS CONNECTOR IS MOLDED ONTO THE WIRE AND MUST REMAIN ON TO MAINTAIN THE WATER TIGHTNESS OF THE ELECTRICAL SYSTEM.**

#### NOTICE

TFT's Master Stream 1250 ER Nozzle Electric Actuator Box must be on the TOP Side for its Edge to line up with Monitor Waterway Top Body, as shown.

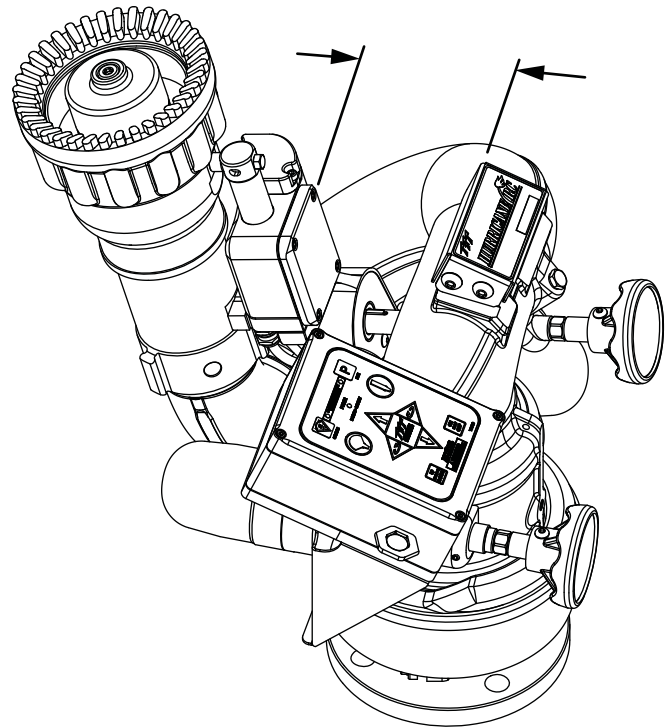

Fig 4.3  
Correct ER Nozzle Install Orientation

#### CAUTION

The nozzle threads must match the threads of the Hurricane monitor in both size and type. Mismatched or damaged threads may cause the nozzle to leak or uncouple under pressure and could cause injury.

#### CAUTION

Do not connect brass to aluminum. Dissimilar metals coupled together can cause galvanic corrosion that will seize the threaded joint or cause complete loss of thread engagement. If dissimilar metals must be coupled together, the effects of corrosion can be greatly delayed by various coatings on the metal such as powder paint, hard anodizing, or silicone grease.

## 4.4 PRESSURE GAGE PORT

There is a 1/4" NPT female threaded hole located behind the elevation hand wheel for the installation of a pressure gage if desired. This hole has a pipe plug installed from the factory. Unscrew the pipe plug and install the gage using pipe sealant. Make sure that the gage does not interfere with the handwheel.

## 4.5 AUTOMATIC DRAIN

There is an automatic drain on the Hurricane and Hurricane RC installed from the factory, that will empty the water from the low point of the lower bend to prevent freezing (Figure 3.2A and 3.2B). The valve closes when the internal pressure is approximately 5 psi (0.3 bar) or above and opens when the internal pressure is below 5 psi (0.3 bar).

In areas that experience freezing, it is important that the automatic drain NOT be disabled. If however, there is no chance of freezing, the following procedure will eliminate the drain valve function.

Refer to the appropriate exploded view in Section 9.0.

- 1) Unscrew the drain assembly from the monitor and remove the screw and washer.
- 2) Turn over the rubber drain valve so that the raised edge is facing down, against the face of the housing.
- 3) Reinstall the washer and screw. Reinstall the drain assembly.

A secondary drain valve should be installed on the monitor's inlet piping to drain water in the riser.

## 4.6 HANDLE INSTALLATION

For the manual HURRICANE, the rotation handle must be attached to the monitor in order to complete the installation process. Attach the handle with the supplied hardware. Use the loctite in the instruction packet to coat the threads of the mounting screws.

## 5.0 OPERATION

### 5.1 HORIZONTAL ROTATION CONTROL

The HURRICANE can rotate from side to side on its swivel base. Depending on model, lift the rotation lock level or loosen rotation lock knob. Rotate the monitor right or left using the handle mounted on the top of the monitor. To lock the monitor in position, depress the rotation lock or tighten the rotation lock knob. A small spring holds the rotation lock lever in the unlocked position when it is disengaged. When the monitor is not in use, the rotation lock lever or rotation lock knob should be kept in the locked position.

### 5.2 ELEVATION CONTROL

The hand wheel controls the nozzle elevation. Turn the hand wheel clockwise to raise the nozzle and counter clockwise to lower it.

### 5.3 RECOMMENDED PARK POSITION

For truck mounted applications, it is recommended that the monitor be parked in a position such that the monitor's nozzle rests against a bracket or support surface. This will minimize bouncing of the nozzle when the apparatus is traveling. Always be sure the monitor is properly parked before moving the truck and know the overall height to avoid damage from overhead obstructions such as doors or bridges.

On many vehicle installations, the monitor is the highest point on the apparatus. Often it is critical that the monitor be properly parked before driving to avoid damage to overhead obstructions, such as door openings. In these cases, the use of a switch wired into the apparatus's "door open" circuit is highly recommended. The switch would be wired to give a "door open" signal if the monitor is not in the parked position. Due to the variety of possible mountings and nozzles, it is the installer's responsibility to supply the appropriate switch with mounting and wire it into their system. Always check parked position of monitor before moving apparatus.

See LIY-500 for information on programming PARK position.

### 5.4 OVERRIDE KNOBS

In the event of electrical system failure of the monitor or fire truck, the Hurricane RC is factory supplied with override knobs so the monitor may be manually operated. To make the Hurricane RC more compact, the override knobs may be removed. The drive shafts have a hex so an 11/16" wrench or socket may be used for manual override. Each drive shaft also has a secondary hex at mid shaft so the shaft may be shortened by cutting and still have a wrenching hex. The wrenching hexes are shown in figure 5.4.

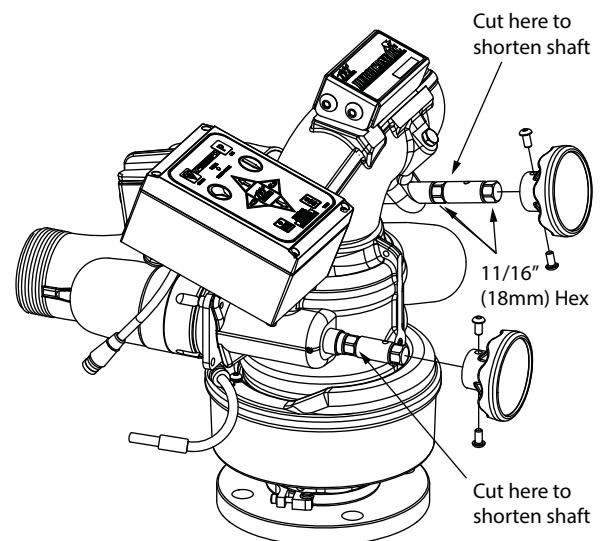

Fig 5.4  
Wrenching Hexes on Drive Shaft

## 6.0 FLOWS AND PRESSURES

The Hurricane and Hurricane RC monitor is designed for a maximum pressure of 200 psi (14 bar). See section 3.1 for flow pressure operating envelope. Do not exceed these limits.

**⚠ WARNING** The stream exiting a monitor is very powerful and capable of causing injury and property damage. Make sure the monitor is securely attached to the base and pointing in a safe direction before water to the monitor is turned on. Use care in directing the stream.

Because the stream trajectory can obscure the view of the operator, it is recommended that a spotter be used to accurately direct the stream.

### 6.1 STACKED TIPS FLOW AND REACH

| NOZZLE DIAMETER (inches) | INLET PRESSURE (PSI) |                |            |                |            |                |            |                |
|--------------------------|----------------------|----------------|------------|----------------|------------|----------------|------------|----------------|
|                          | 40                   |                | 60         |                | 80         |                | 100        |                |
|                          | FLOW (GPM)           | REACTION (LBS) | FLOW (GPM) | REACTION (LBS) | FLOW (GPM) | REACTION (LBS) | FLOW (GPM) | REACTION (LBS) |
| 1.375                    | 360                  | 120            | 440        | 180            | 500        | 240            | 560        | 300            |
| 1.50                     | 420                  | 140            | 520        | 210            | 600        | 280            | 670        | 350            |
| 1.75                     | 580                  | 190            | 700        | 290            | 810        | 380            | 910        | 480            |
| 2.00                     | 750                  | 250            | 920        | 380            | 1000       | 500            | 1190       | 630            |

| NOZZLE DIAMETER (MM) | INLET PRESSURE (BAR) |               |              |               |              |               |              |               |
|----------------------|----------------------|---------------|--------------|---------------|--------------|---------------|--------------|---------------|
|                      | 2.8                  |               | 4.1          |               | 5.5          |               | 7            |               |
|                      | FLOW (l/min)         | REACTION (KG) | FLOW (l/min) | REACTION (KG) | FLOW (l/min) | REACTION (KG) | FLOW (l/min) | REACTION (KG) |
| 35                   | 1360                 | 50            | 1670         | 80            | 1890         | 110           | 2120         | 140           |
| 38                   | 1590                 | 60            | 1970         | 100           | 2270         | 130           | 2540         | 160           |
| 45                   | 2200                 | 90            | 2650         | 130           | 3070         | 170           | 3440         | 220           |
| 50                   | 2840                 | 110           | 3480         | 170           | 4010         | 230           | 4500         | 290           |

Fig. 6.1A  
Stacked Tips Flow Table

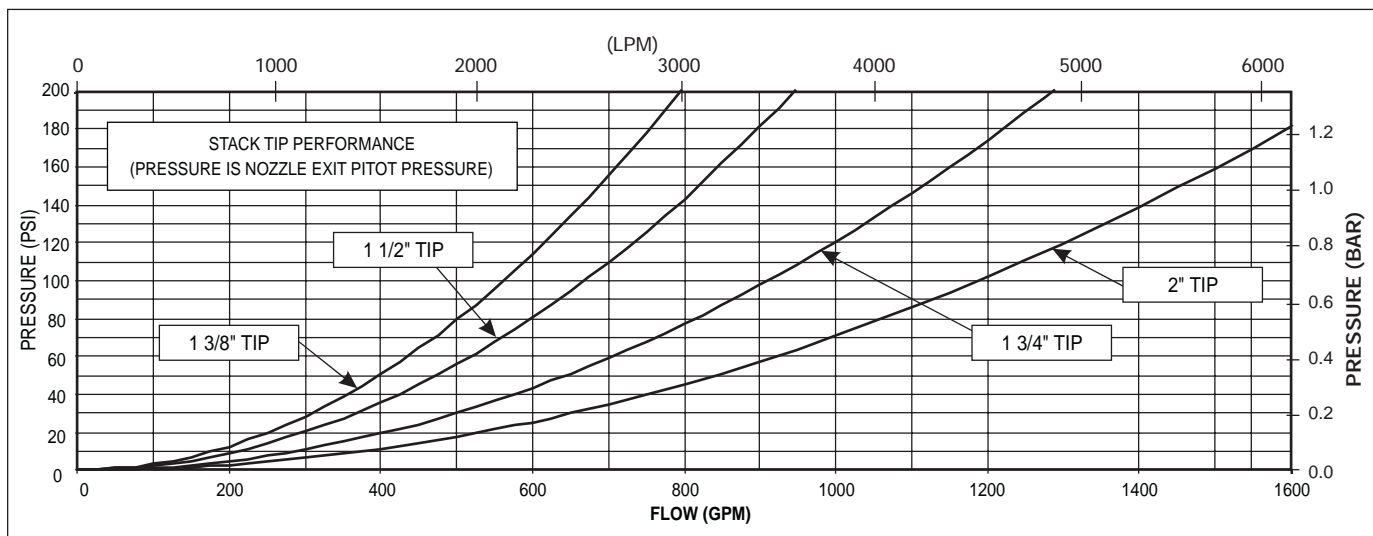

Fig 6.1B  
Stacked Tips Flow Graph

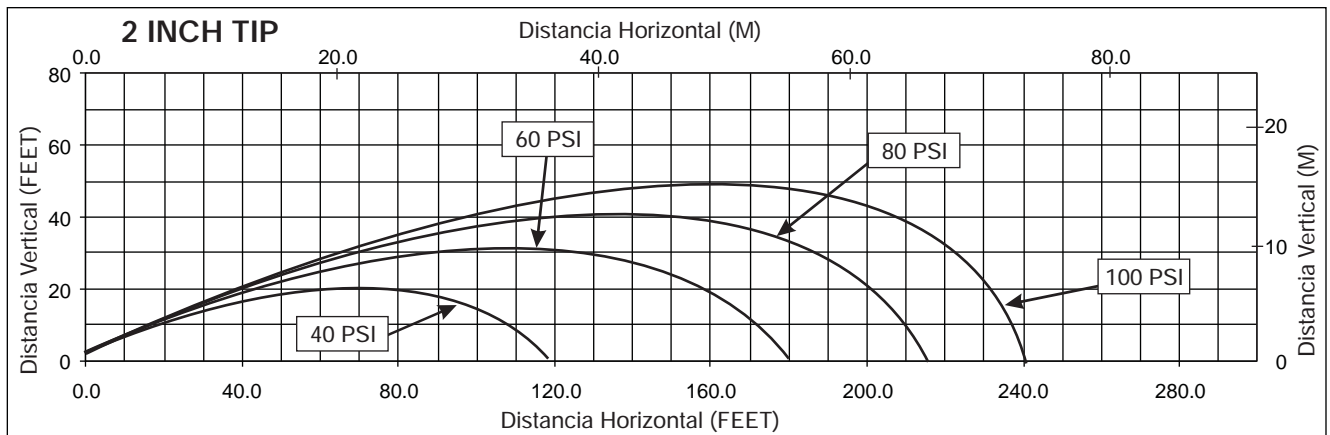
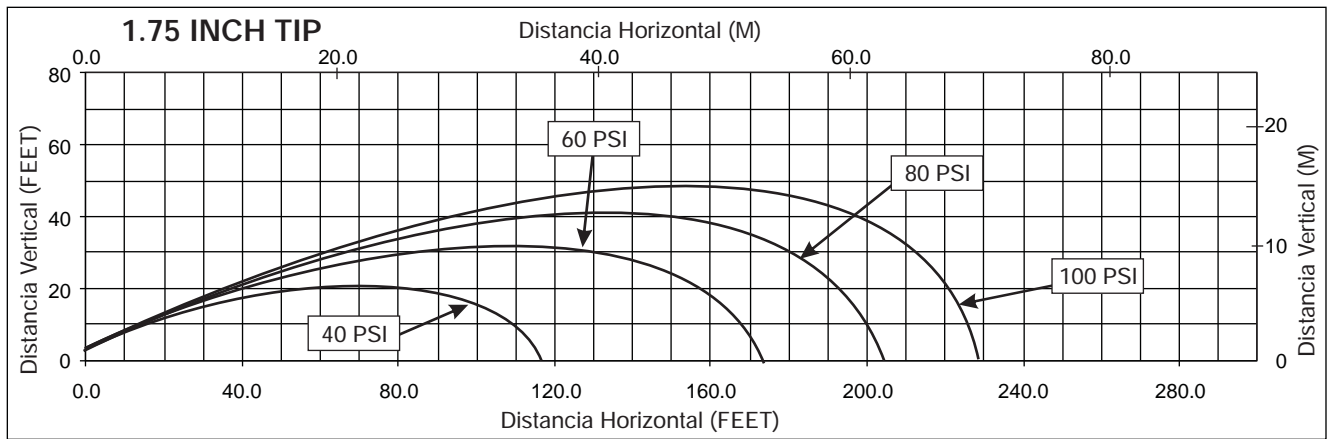
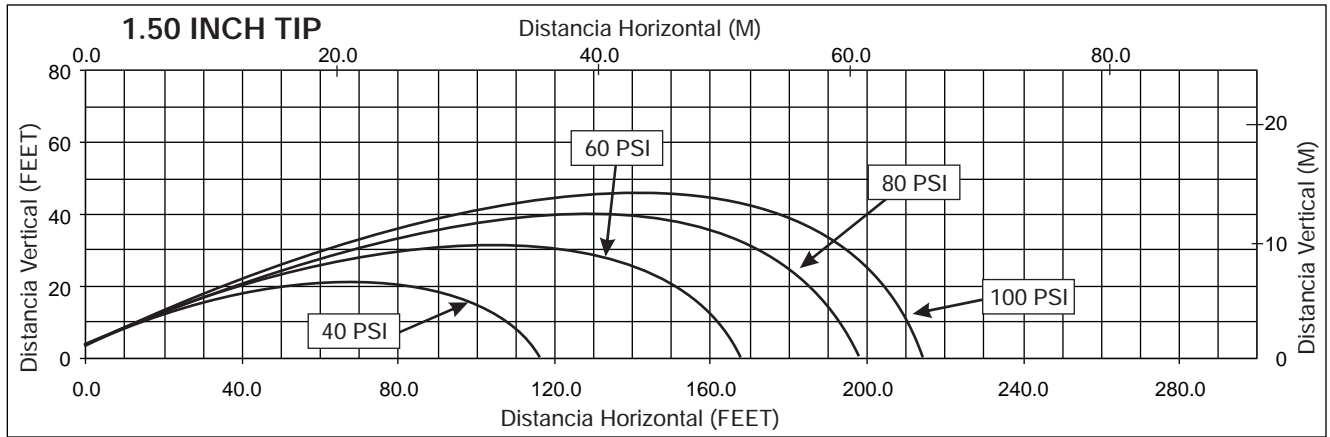
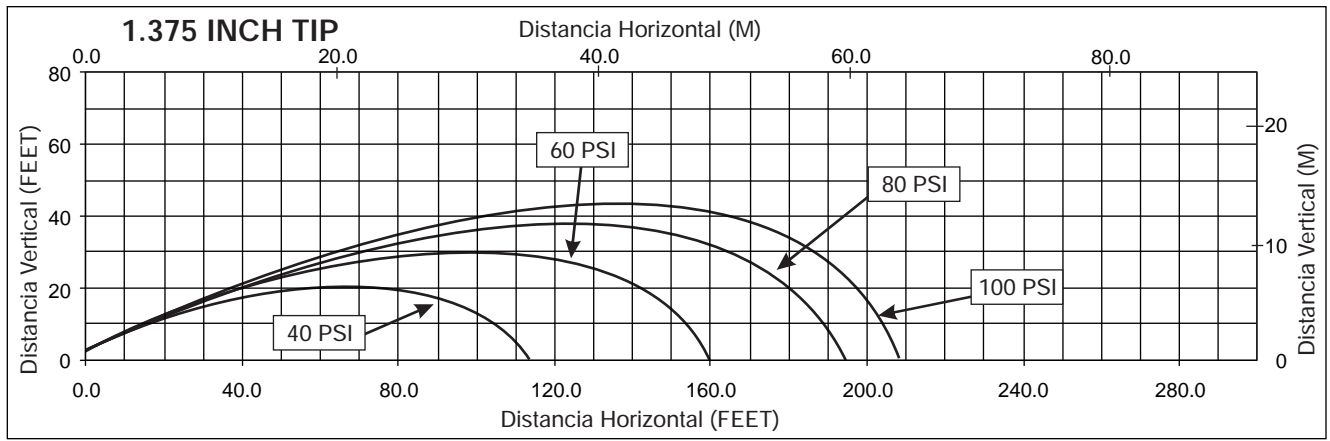
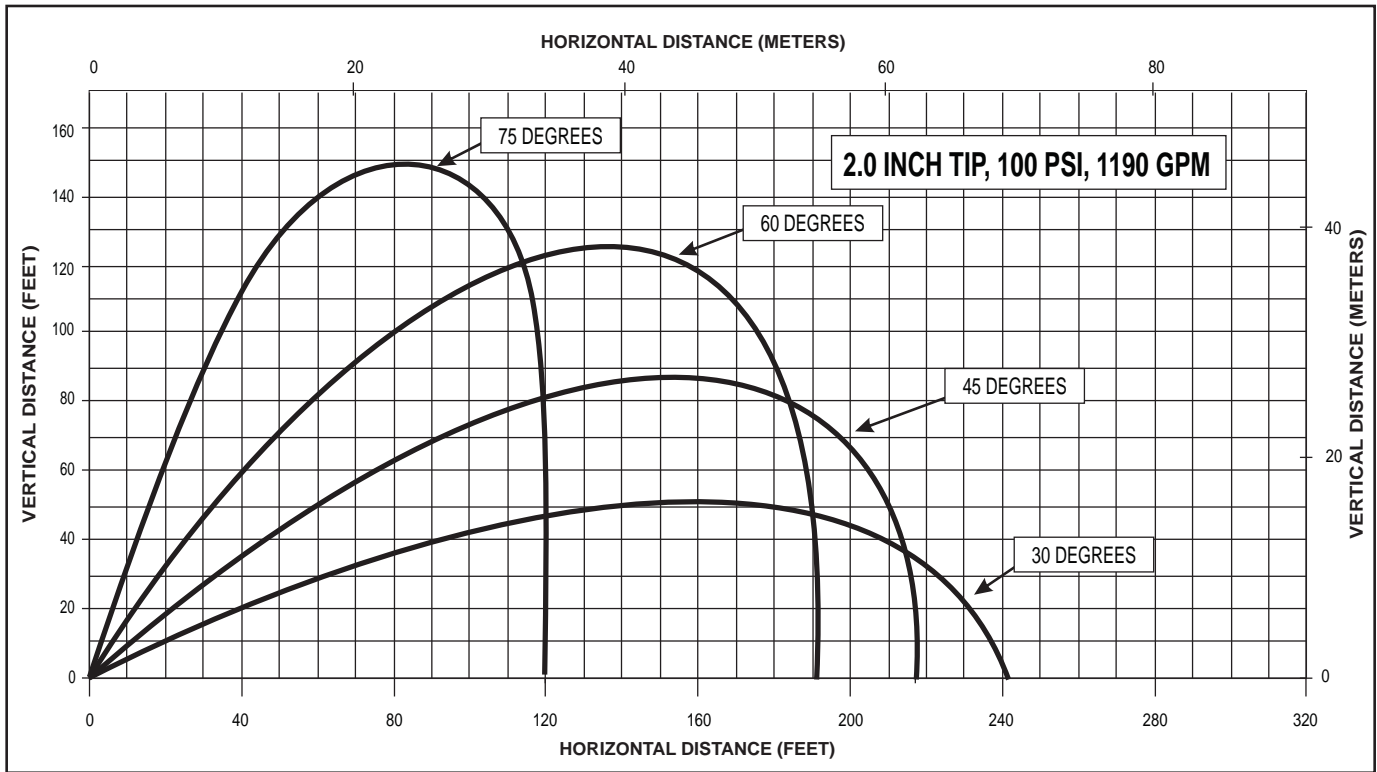
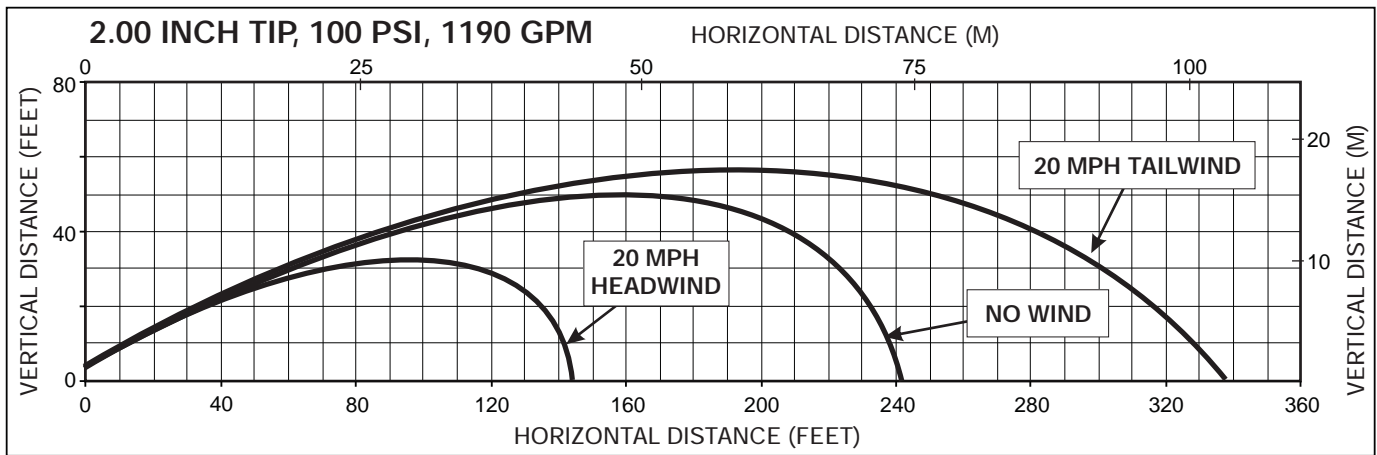

Fig 6.1C  
Stacked Tips Stream Trajectory Graphs



This graph is approximate only.  
 Critical applications should be tested in actual conditions to verify adequate reach.

Fig 6.1D  
 Effects of Elevation on Trajectory



This graph shows approximately how a moderate wind can affect stream reach. 1 ft = 0.3048 m

Fig 6.1E  
 Effects of Wind on Reach



## 6.2 AUTOMATIC MASTERSTREAM NOZZLES

Automatic nozzles maintain a constant pressure by adjusting their orifice to match the available flow. Consult the nozzle's manufacturer for maximum flow and pressure ratings. In all cases, do not exceed 1250 gpm (4800 l/min). TFT's Masterstream 1250 Nozzle has a 150-1250 gpm (600 - 4800 l/min) flow range. Masterstream 1250 Nozzle operating instructions (Item Number LIM-030) are available on TFT's website: [www.tft.com](http://www.tft.com)

## 6.3 STREAM STRAIGHTENERS

### 6.3.1 STREAM STRAIGHTENERS WITH STACKED TIPS

Stream quality and reach, especially with stacked tip (smooth bore) nozzles, is generally improved with a stream straightener because the water must make many bends before it reaches the nozzle.

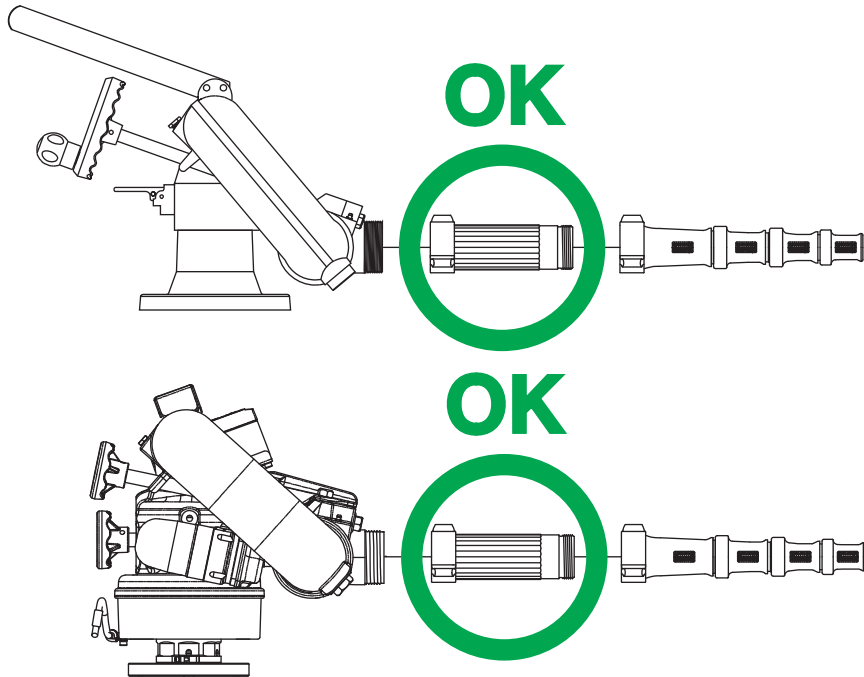

### 6.3.2 STREAM STRAIGHTENERS WITH FOG NOZZLES

When using a fog nozzle, it is recommended that no stream straightener be used since the fog nozzle's flow path generally serves as a stream straightener. Use of a stream straightener with a fog nozzle will increase the stress on the monitor's gear train and may lead to premature wear.

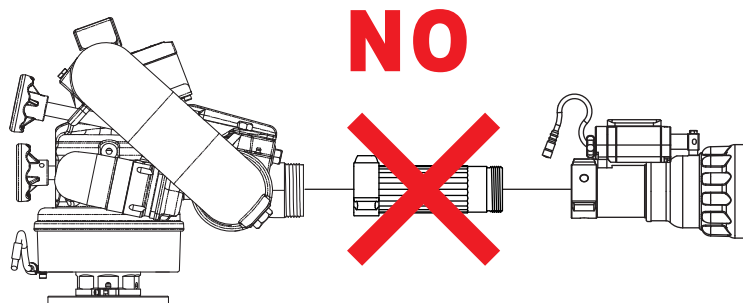

## 7.0 MAINTENANCE AND INSPECTION

The Hurricane monitor requires little maintenance. The monitor should be kept clean and free of dirt. All controls should be checked for freedom of movement and proper operation before each use. Any inoperable or damaged parts should be repaired or replaced immediately.

- For Hurricane Fixed Monitor make sure that the monitor swivels freely on its base when the anti-rotation lock is released and that the monitor will not rotate when the anti-rotation lock is engaged.
- Make sure that the monitor's axis' rotate freely and without binding throughout its range of travel.
- Make sure that there are no leaks when the monitor is flowing water.
- Make sure the nozzle is free of debris.

Equipment can be returned to the factory for service and/or testing.

### 7.1 LUBRICATION

#### 7.1.1 ELEVATION CONTROL WORM GEAR

In the event that the operation becomes stiff, grease may be applied to the elevation worm gear grease port shown in Fig. 3.2. Turn the hand wheel to raise the nozzle to its highest position and pump medium viscosity automotive chassis grease into the grease fitting. Apply only enough grease to restore normal operation. If greasing does not restore normal operation, inspect for other causes of stiff operation.. See Fig. 3.2 for grease zerk location.

#### 7.1.2 HORIZONTAL ROTATION WORM GEAR

The Hurricane RC and Hurricane monitor generally should not require greasing in the Horizontal (left-right) worm gear. In the event that the operation becomes stiff, grease may be applied to the horizontal worm gear grease port shown in Fig. 3.2A and Fig. 3.2B. Use medium viscosity automotive chassis grease. Apply only enough grease to restore normal operation. If greasing does not restore normal operation, inspect for other causes of stiff operation.

**Note: Do not over pump grease to Horizontal worm gear. The monitor's Horizontal worm gear greased areas lead to the wire skirt/cable guide that would trap several pounds of grease before becoming visible.**

## 8.0 TROUBLESHOOTING

| SYMPTOM                     | POSSIBLE CAUSE                             | REMEDY                                    |
|-----------------------------|--|---|
| Leaks                       | Debris or damage in seal area              | Clean out debris or replace damaged parts |
| Elevation Binding           | Debris or damage to elevation drive parts  | Clean out debris or replace damaged parts |
|                             | Lack of lubricant                          | Grease, see section 7.1                   |
| Horizontal Rotation Binding | Debris or damage to horizontal drive parts | Clean out debris or replace damaged parts |
|                             | Lack of lubricant                          | Grease, see section 7.1                   |

## **9.0 HURRICANE DRAWING & PARTS LIST**

**9.1 HURRICANE FIXED (XFI- SERIES)**

**9.2 HURRICANE FIXED EXTENDED (XFIE-SERIES)**

**9.3 HURRICANE DUAL HANDWHEEL (XFIH-D SERIES)**

**9.4 HURRICANE TILLER FOR 4.5" QUICK CONNECT AND VUM (XFIH-T SERIES)**

**9.5 HURRICANE RC MONITOR (XFIH-E SERIES)**

**9.6 ELEVATION CHAIN DRIVE ASSEMBLY**

**9.7 GEAR MOTOR ASSEMBLY**

**9.8 MONITOR CONTROL BOX ASSEMBLY**

## 9.1 HURRICANE FIXED (XFI SERIES)

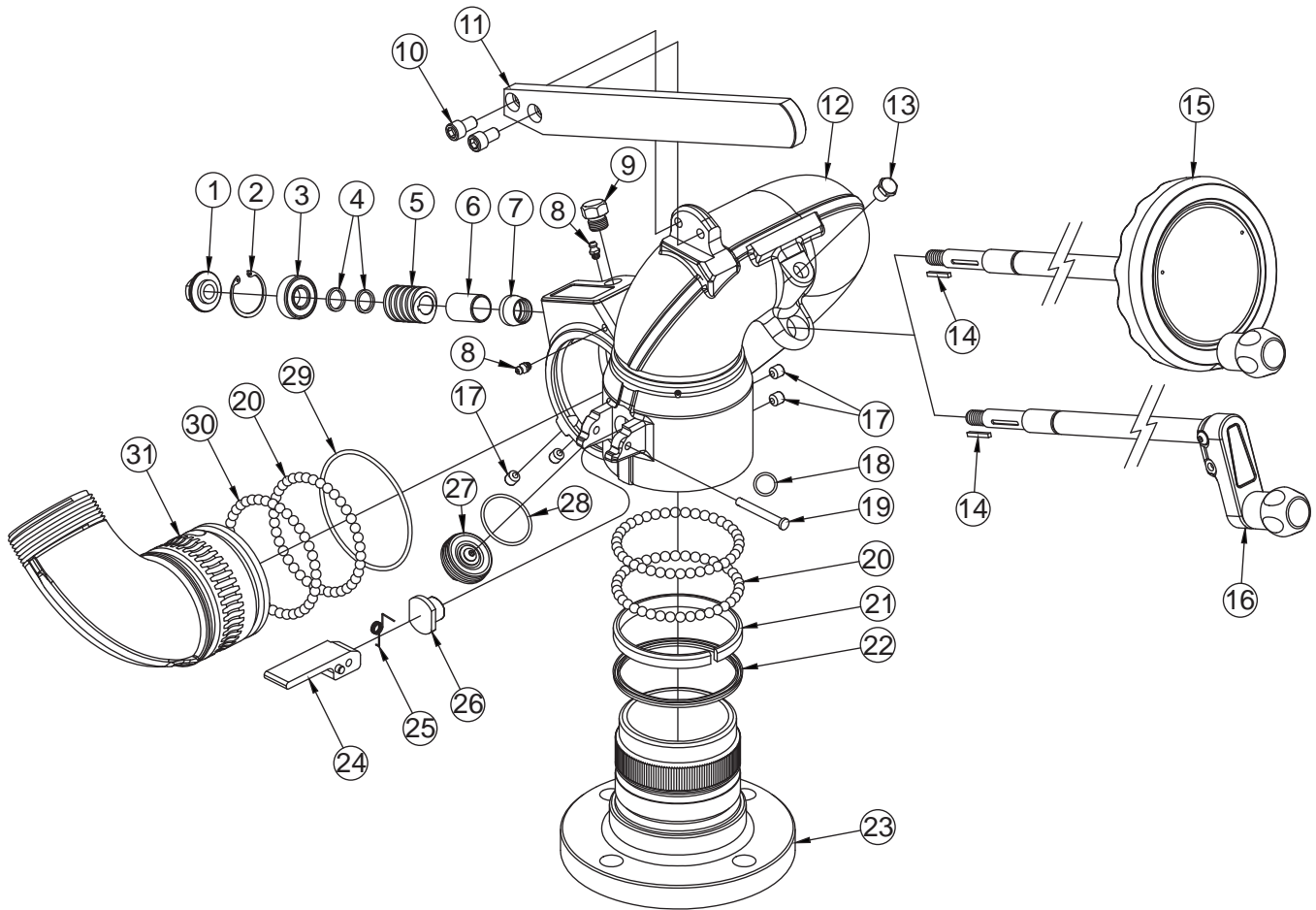

| #  | DESCRIPTION                          | QTY | PART #       |
|--|--------------------------------------|-----|--------------|
| 1  | SHAFT NUT                            | 1   | X210         |
| 2  | SNAP RING                            | 1   | VR4220       |
| 3  | BEARING                              | 1   | VM4252       |
| 4  | SPACER                               | 2   | X235         |
| 5  | 12 DP WORM                           | 1   | X220         |
| 6  | BUSHING                              | 1   | X230         |
| 7  | BOOT                                 | 1   | X240         |
| 8  | GREASE FITTING 1/4-28                | 2   | VT25-28ZERK  |
| 9  | HEX CAP                              | 1   | X355         |
| 10   | 3/8-16 X 5/8 SOCKET HEAD SCREW       | 2   | VT37-16SH625 |
| 11   | HANDLE                               | 1   | X363         |
| 12   | BIG BEND/BELL                        | 1   | X805         |
| 13   | 1/4"NPT HEX HEAD PLUG                | 1   | VFHP2M       |
| 14   | KEY                                  | 1   | X225         |
| 15   | HANDWHEEL SUBASSEMBLY                | 1   | X815         |
| 16   | CRANK SUBASSEMBLY                    | 1   | X815-Z       |
| 17   | 3/8-24 X 3/8 SOCKET SET SCREW        | 4   | VT37-24SS375 |
| 18   | CLEVIS PIN RETAINER                  | 1   | X137         |
| 19   | CLEVIS PIN 1/4 X 2                   | 1   | X180         |
| 20   | 5/16" TORLON BALL (38) PER RACE      | 114 | VB.312TO     |
| 21   | WEAR STRIP                           | 1   | X120         |
| 22   | CUP SEAL                             | 1   | X125         |
| 23   | FLANGE ALUM 3"ANSI/XF                | 1   | X410-3ASA    |
|  | TRUCK ADAPTER 3.0"NPTF               |     | X411PL       |
|  | FLANGE ALUM 4"ANSI/XF                |     | X414-4ASA    |
| 24   | ROTATIONAL LOCK LEVER/PIN - ASSEMBLY | 1   | X821         |
| 25   | ROTATION LOCK LEVER SPRING           | 1   | X152         |
| 26   | ROTATION LOCK INSERT                 | 1   | X170         |
| 27   | DRAIN VALVE SUBASSEMBLY              | 1   | X840         |
| 28   | O-RING-130                           | 1   | VO-130       |
| 29   | O-RING-241                           | 1   | VO-241       |
| 30   | 5/16" SS BALL                        | 38  | VB.312       |
| 31   | ELBOW ALUM 2.5"                      | 1   | X339*        |
| <b>* - CONSULT FACTORY FOR SPECIAL THREADS</b> |                                      |     |              |

## 9.2 HURRICANE FIXED EXTENDED (XFIE SERIES)

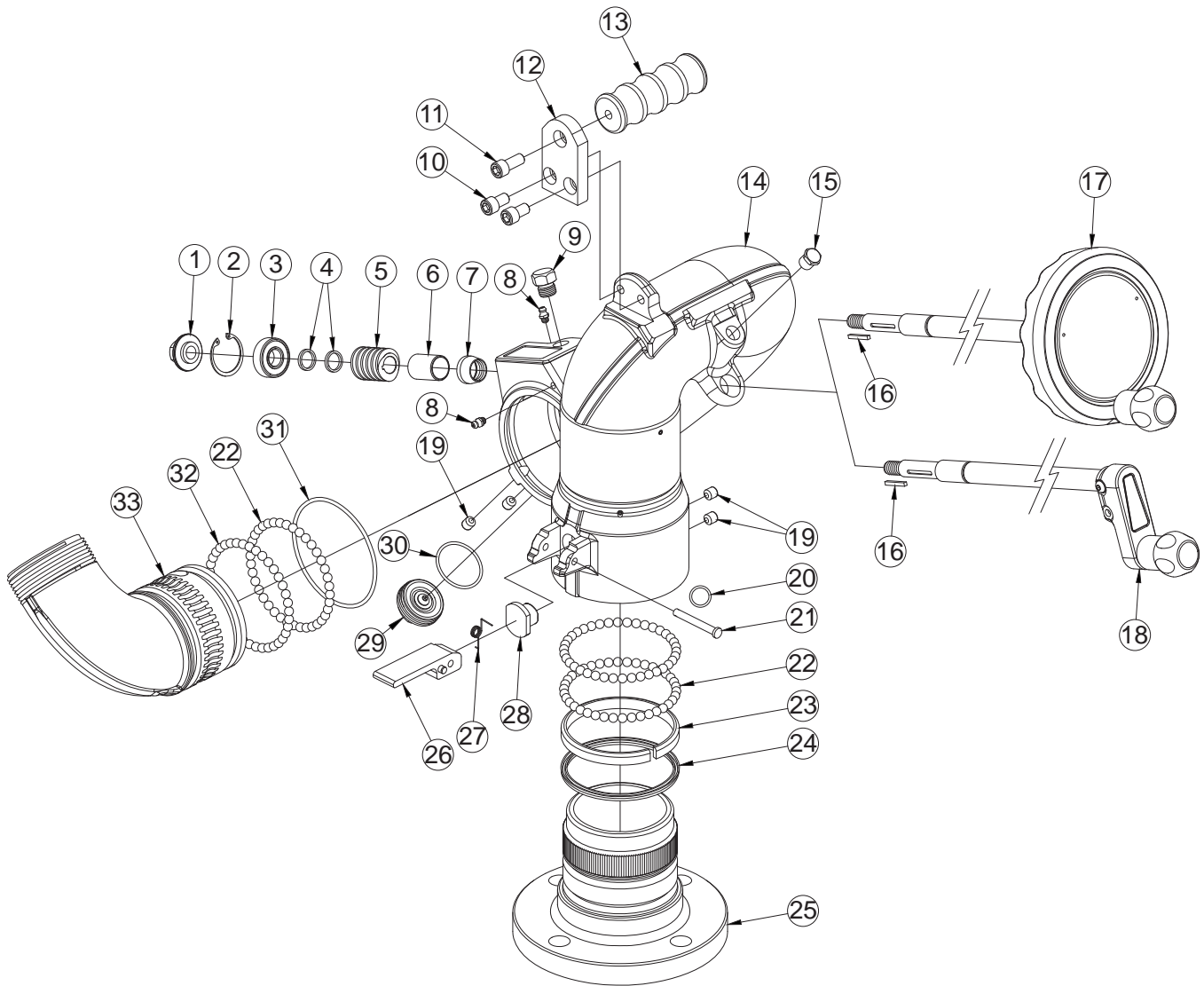



| #  | DESCRIPTION                          | QTY | PART #       |
|--|--------------------------------------|-----|--------------|
| 1  | SHAFT NUT                            | 1   | X210         |
| 2  | SNAP RING                            | 1   | VR4220       |
| 3  | BEARING                              | 1   | VM4252       |
| 4  | SPACER                               | 2   | X235         |
| 5  | 12 DP WORM                           | 1   | X220         |
| 6  | BUSHING                              | 1   | X230         |
| 7  | BOOT                                 | 1   | X240         |
| 8  | GREASE FITTING 1/4-28                | 2   | VT25-28ZERK  |
| 9  | HEX CAP                              | 1   | X355         |
| 10   | 3/8-16 X 5/8 SOCKET HEAD SCREW       | 2   | VT37-16SH625 |
| 11   | 3/8-16 X 7/8 SOCKET HEAD SCREW       | 1   | VT37-16SH875 |
| 12   | TOMBSTONE                            | 1   | X365         |
| 13   | PEG                                  | 1   | X362         |
| 14   | EXTENDED BEND                        | 1   | X805-E       |
| 15   | 1/4"NPT HEX HEAD PLUG                | 1   | VFHP2M       |
| 16   | KEY                                  | 1   | X225         |
| 17   | HANDWHEEL SUBASSEMBLY                | 1   | X815         |
| 18   | CRANK SUBASSEMBLY                    | 1   | X815-Z       |
| 19   | 3/8-24 X 3/8 SOCKET SET SCREW        | 4   | VT37-24SS375 |
| 20   | CLEVIS PIN RETAINER                  | 1   | X137         |
| 21   | CLEVIS PIN 1/4 X 2                   | 1   | X180         |
| 22   | 5/16" TORLON BALL (38) PER RACE      | 114 | VB.312TO     |
| 23   | WEAR STRIP                           | 1   | X120         |
| 24   | CUP SEAL                             | 1   | X125         |
| 25   | FLANGE ALUM 3"ANSI/XF                | 1   | X410-3ASA    |
|  | TRUCK ADAPTER 3.0"NPTF               |     | X411PL       |
|  | FLANGE ALUM 4"ANSI/XF                |     | X414-4ASA    |
| 26   | ROTATIONAL LOCK LEVER/PIN - ASSEMBLY | 1   | X821         |
| 27   | ROTATION LOCK LEVER SPRING           | 1   | X152         |
| 28   | ROTATION LOCK INSERT                 | 1   | X170         |
| 29   | DRAIN VALVE SUBASSEMBLY              | 1   | X840         |
| 30   | O-RING-130                           | 1   | VO-130       |
| 31   | O-RING-241                           | 1   | VO-241       |
| 32   | 5/16" SS BALL                        | 38  | VB.312       |
| 33   | ELBOW ALUM 2.5"                      | 1   | X339*        |
| <b>* - CONSULT FACTORY FOR SPECIAL THREADS</b> |                                      |     |              |

### 9.3 HURRICANE DUAL HANDWHEEL (XFIH-D SERIES)

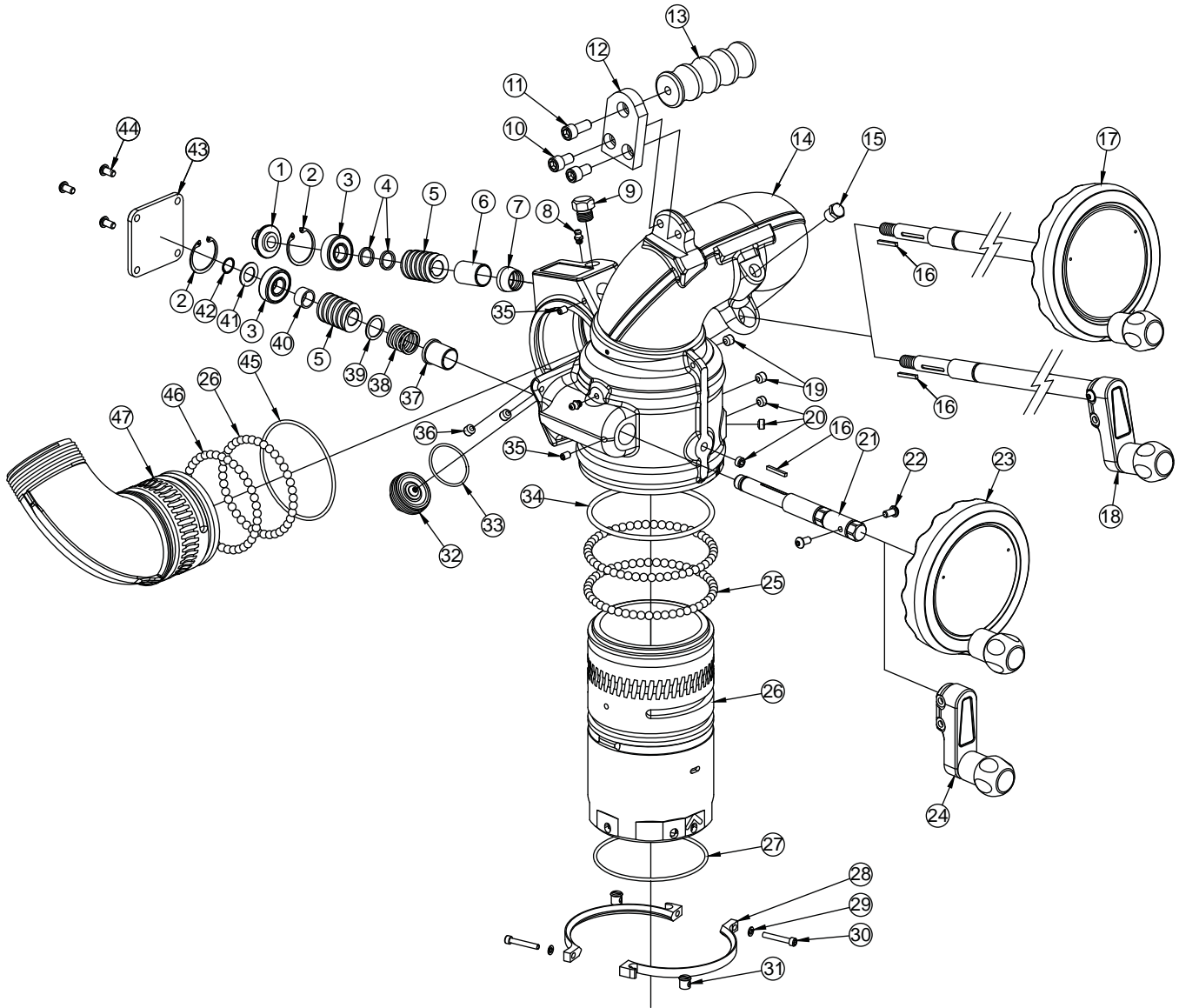

| #  | DESCRIPTION                        | QTY | PART #       |
|----|------------------------------------|-----|--------------|
| 1  | SHAFT NUT                          | 1   | X210         |
| 2  | SNAP RING                          | 2   | VR4220       |
| 3  | BEARING                            | 2   | VM4252       |
| 4  | SPACER                             | 2   | X235         |
| 5  | 12 DP WORM                         | 2   | X220         |
| 6  | BUSHING                            | 1   | X230         |
| 7  | BOOT                               | 1   | X240         |
| 8  | GREASE FITTING 1/4-28              | 2   | VT25-28ZERK  |
| 9  | HEX CAP                            | 1   | X355         |
| 10 | 3/8-16 X 5/8 SOCKET HEAD SCREW     | 2   | VT37-16SH625 |
| 11 | 3/8-16 X 7/8 SOCKET HEAD SCREW     | 1   | VT37-16SH875 |
| 12 | TOMBSTONE                          | 1   | X365         |
| 13 | PEG                                | 1   | X362         |
| 14 | BELL/BIG BEND                      | 1   | X806         |
| 15 | 1/4"NPT HEX HEAD PLUG              | 1   | VFHP2M       |
| 16 | KEY                                | 2   | X225         |
| 17 | HANDWHEEL SUBASSEMBLY              | 1   | X815         |
| 18 | CRANK SUBASSEMBLY                  | 1   | X815-Z       |
| 19 | 3/8-24 X 5/16 SOCKET SET SCREW     | 2   | VT37-24SS312 |
| 20 | 3/8-24 X 3/8 SOCKET SET SCREW      | 5   | VT37-24SS250 |
| 21 | DRIVE SHAFT                        | 1   | Y4160        |
| 22 | 1/4-20 X 1/2 BUTTON HEAD SCREW     | 2   | VT25-20BH500 |
| 23 | SIDE TO SIDE HANDWHEEL SUBASSEMBLY | 1   | Y4940        |
| 24 | CRANK WITH KNOB SUBASSEMBLY        | 1   | A1623        |
| 25 | 5/16" TORLON BALL (49) PER RACE    | 136 | VB.312TO     |

| #  | DESCRIPTION                        | QTY | PART #       |
|--|------------------------------------|-----|--------------|
| 26   | BASE CODE-RPF 4"                   | 1   | Y4400A       |
|  | BASE SHORT CODE-RPF 4"             |     | Y4401A       |
|  | BASE CODE-RLF 3"                   |     | Y4405A       |
|  | BASE QUICK CONNECT 4.5"NHF SUBASSY |     | Y4960        |
| 27   | VO-RING-244                        | 1   | VO-244       |
|  | VO-RING-236                        |     | VO-236       |
| 28   | 4" MONITOR BASE CLAMP              | 2   | Y4435        |
|  | 3" MONITOR BASE CLAMP              |     | Y4436        |
| 29   | WASHER                             | 2   | VW360X200-04 |
| 30   | 10-24 X 1 1/4 SOCKET HEAD SCREW    | 2   | VT10-24SH1.2 |
| 31   | CYLINDER NUT                       | 2   | Y4437        |
| 32   | DRAIN VALVE SUBASSEMBLY            | 1   | X840         |
| 33   | VO-RING-130                        | 1   | VO-130       |
| 34   | VO-RING-350                        | 1   | VO-350       |
| 35   | 1/4-28 X 3/8 SOCKET SET SCREW      | 2   | VT25-28SS375 |
| 36   | 3/8-24 X 5/16 SET SCREW FLAT POINT | 2   | VT37F24SS312 |
| 37   | HEADED BUSHING                     | 1   | Y4141        |
| 38   | SHAFT SPRING STAINLESS             | 1   | Y4159        |
| 39   | WASHER ACETAL                      | 1   | VW1.0X759-04 |
| 40   | SPACER                             | 1   | Y4150        |
| 41   | WASHER                             | 1   | VW97X595-048 |
| 42   | SMALLEY RING                       | 1   | VR4365       |
| 43   | COVER PLATE                        | 1   | Y4164        |
| 44   | 1/4-28 X 1/2 BUTTON HEAD SCREW     | 3   | VT25-28BH500 |
| 45   | O-RING-241                         | 1   | VO-241       |
| 46   | 5/16" SS BALL                      | 38  | VB.312       |
| 47   | ELBOW ALUM 2.5"                    | 1   | X333*        |
| <b>* - CONSULT FACTORY FOR SPECIAL THREADS</b> |                                    |     |              |

## 9.4 HURRICANE TILLER FOR 4.5" QUICK CONNECT AND VUM (XFIH-T SERIES)

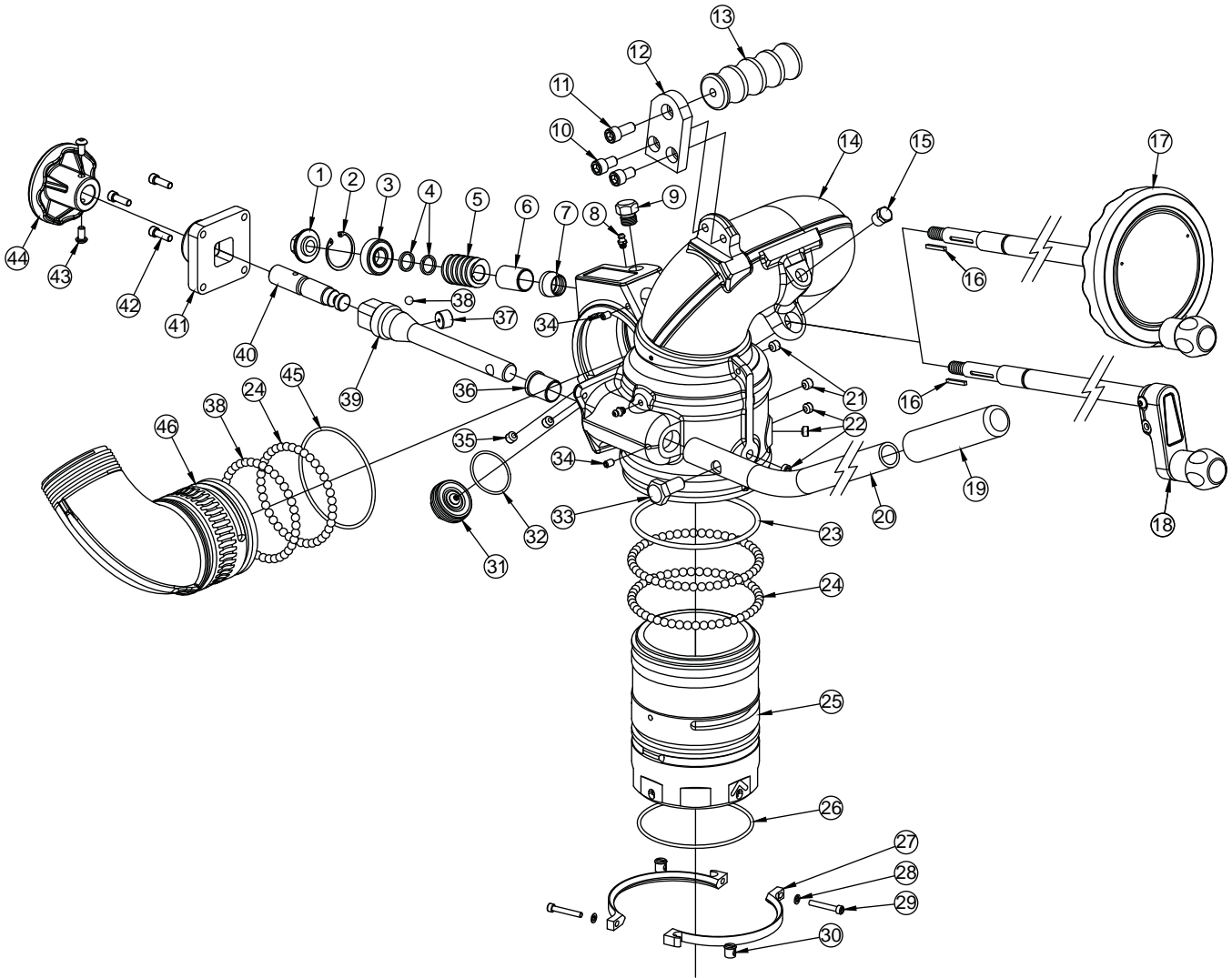

| #  | DESCRIPTION                     | QTY | PART #       |
|----|---------------------------------|-----|--------------|
| 1  | SHAFT NUT                       | 1   | X210         |
| 2  | SNAP RING                       | 1   | VR4220       |
| 3  | BEARING                         | 1   | VM4252       |
| 4  | SPACER                          | 2   | X235         |
| 5  | 12 DP WORM                      | 1   | X220         |
| 6  | BUSHING                         | 1   | X230         |
| 7  | BOOT                            | 1   | X240         |
| 8  | GREASE FITTING 1/4-28           | 2   | VT25-28ZERK  |
| 9  | HEX CAP                         | 1   | X355         |
| 10 | 3/8-16 X 5/8 SOCKET HEAD SCREW  | 2   | VT37-16SH625 |
| 11 | 3/8-16 X 7/8 SOCKET HEAD SCREW  | 1   | VT37-16SH875 |
| 12 | TOMBSTONE                       | 1   | X365         |
| 13 | PEG                             | 1   | X362         |
| 14 | BELL/BIG BEND                   | 1   | X806         |
| 15 | 1/4"NPT HEX HEAD PLUG           | 1   | VFHP2M       |
| 16 | KEY                             | 1   | X225         |
| 17 | HANDWHEEL SUBASSEMBLY           | 1   | X815         |
| 18 | CRANK SUBASSEMBLY               | 1   | X815-Z       |
| 19 | HANDLE GRIP                     | 1   | Z317         |
| 20 | ELEVATION HANDLE                | 1   | Z315         |
| 21 | 3/8-24 X 5/16 SOCKET SET SCREW  | 2   | VT37-24SS312 |
| 22 | 3/8-24 X 3/8 SOCKET SET SCREW   | 5   | VT37-24SS250 |
| 23 | VO-RING-350                     | 1   | VO-350       |
| 24 | 5/16" TORLON BALL (49) PER RACE | 136 | VB.312TO     |

| #  | DESCRIPTION                        | QTY | PART #       |
|--|------------------------------------|-----|--------------|
| 25   | TILLER BASE CODE-RPF 4"            | 1   | Y4402A       |
|  | TILLER BASE CODE-RLF 3"            |     | Y4406A       |
|  | TILLER BASE QUICK CONNECT 4.5"NHF  |     | Y4961        |
| 26   | VO-RING-244                        | 1   | VO-244       |
|  | VO-RING-236                        |     | VO-236       |
| 27   | 4" MONITOR BASE CLAMP              | 2   | Y4435        |
|  | 3" MONITOR BASE CLAMP              |     | Y4436        |
| 28   | WASHER                             | 2   | VW360X200-04 |
| 29   | 10-24 X 1 1/4 SOCKET HEAD SCREW    | 2   | VT10-24SH1.2 |
| 30   | CYLINDER NUT                       | 2   | Y4437        |
| 31   | DRAIN VALVE SUBASSEMBLY            | 1   | X840         |
| 32   | O-RING-130                         | 1   | VO-130       |
| 33   | 1/2-13 X 1 HEX HEAD BOLT           | 1   | VT50-13HX1.0 |
| 34   | 1/4-28 X 3/8 SOCKET SET SCREW      | 2   | VT25-28SS375 |
| 35   | 3/8-24 X 5/16 SET SCREW FLAT POINT | 2   | VT37F24SS312 |
| 36   | HEADED BUSHING                     | 1   | Y4141        |
| 37   | WEAR DISC                          | 1   | Y4191        |
| 38   | 5/16" SS BALL (38) PER RACE        | 39  | VB.312       |
| 39   | LOCKING BAR                        | 1   | Y4190        |
| 40   | LOCKING BOLT                       | 1   | Y4193        |
| 41   | COVER                              | 1   | Y4192        |
| 42   | 1/4-28 X 3/4 SOCKET HEAD SCREW     | 3   | VT25-28SH750 |
| 43   | 1/4-20 X 1/2 BUTTON HEAD SCREW     | 2   | VT25-20BH500 |
| 44   | KNOB                               | 1   | Z245         |
| 45   | O-RING-241                         | 1   | VO-241       |
| 46   | ELBOW ALUM 2.5"                    | 1   | X333*        |
| <b>* - CONSULT FACTORY FOR SPECIAL THREADS</b> |                                    |     |              |

## 9.5 HURRICANE RC MONITOR (XFIH-E SERIES)

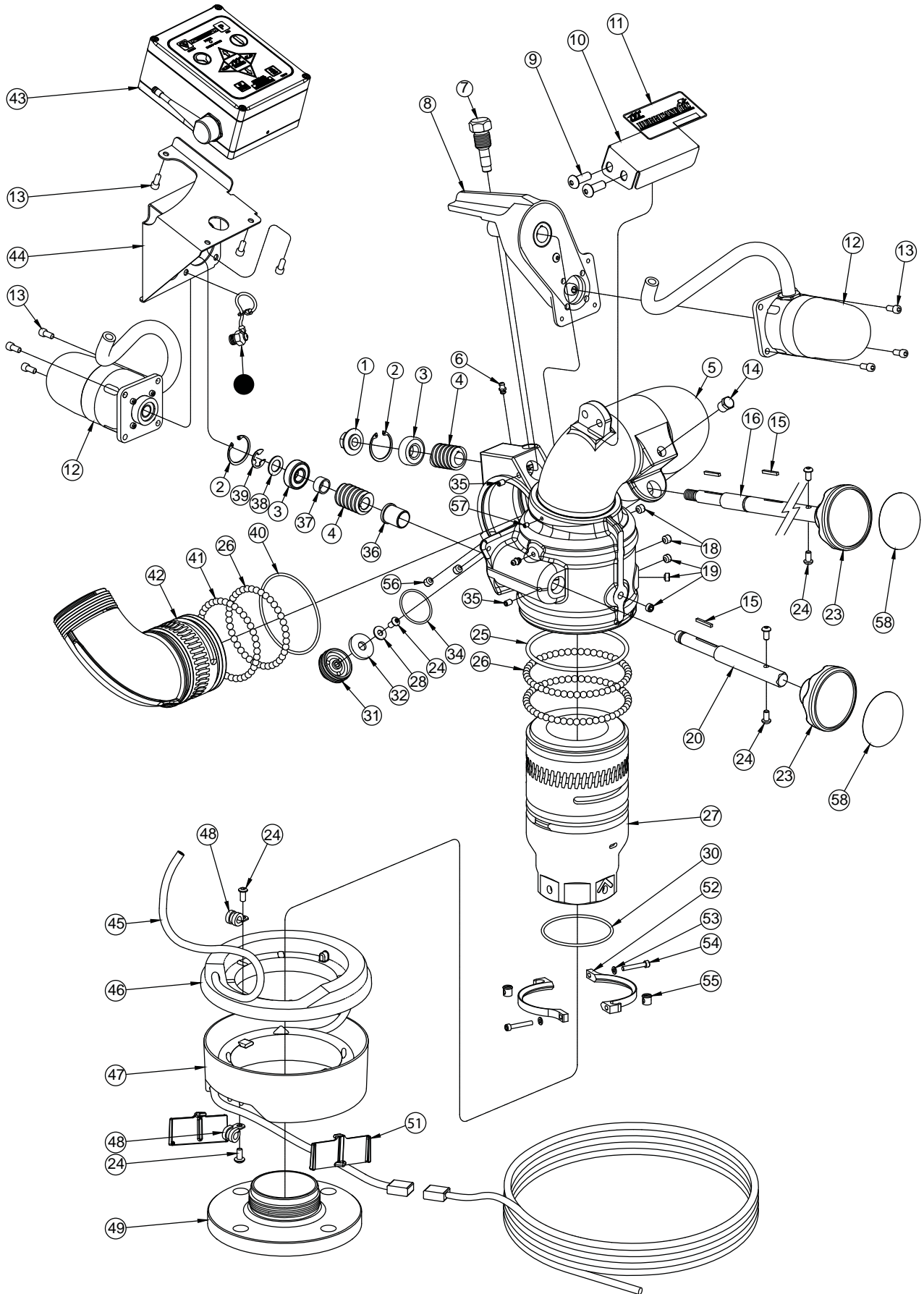



| #  | DESCRIPTION                         | QTY | PART #          |
|----|-------------------------------------|-----|-----------------|
| 1  | SHAFT NUT                           | 1   | X210            |
| 2  | SNAP RING                           | 2   | VR4220          |
| 3  | BEARING                             | 2   | VM4252          |
| 4  | 12 DP WORM                          | 2   | X220            |
| 5  | BELL/BIG BEND                       | 1   | X806            |
| 6  | GREASE FITTING 1/4-28               | 2   | VT25-28ZERK     |
| 7  | HEX MOUNTING SCREW                  | 1   | X258            |
| 8  | CHAIN DRIVE ASSEMBLY                | 1   | SEE SECTION 9.6 |
| 9  | 3/8-16 X 1 BUTTON HEAD SCREW        | 2   | VT37-16BH1.0    |
| 10 | LABEL BRACKET                       | 1   | X395            |
| 11 | LABEL: HURRICANE RC                 | 1   | YL300           |
| 12 | GEAR MOTOR ASSEMBLY                 | 2   | SEE SECTION 9.7 |
| 13 | 1/4-28 X 1/2 SOCKET HEAD SCREW      | 9   | VT25-28SH500    |
| 14 | 1/4"NPT HEX HEAD PLUG               | 1   | VFHP2M          |
| 15 | KEY                                 | 3   | X225            |
| 16 | ELEVATION SHAFT                     | 1   | X272            |
|    | SHORTENED ELEVATION SHAFT           |     | X273            |
| 17 | OVERRIDE KNOB LABEL                 | 2   | Y4176           |
| 18 | 3/8-24 X 5/16 SOCKET SET SCREW      | 2   | VT37-24SS312    |
| 19 | 3/8-24 X 3/8 SOCKET SET SCREW       | 5   | VT37-24SS250    |
| 20 | DRIVE SHAFT                         | 1   | Y4160           |
| 23 | KNOB                                | 2   | Z245            |
| 24 | 1/4-20 X 1/2 BUTTON HEAD SCREW      | 7   | VT25-20BH500    |
| 25 | O-RING-350                          | 1   | VO-350          |
| 26 | BALL 5/16 TORLON (49) PER RACE      | 136 | VB.312TO        |
| 27 | BASE CODE-RPF 4"                    | 1   | Y4400A          |
|    | BASE CODE-RLF 3"                    |     | Y4405A          |
|    | BASE QUICK CONNECT 4.5"NHF SUBASSY. |     | Y4960           |
| 28 | FLAT WASHER                         | 1   | VW687X281-50    |
| 30 | VO-RING-244                         | 1   | VO-244          |
|    | VO-RING-236                         |     | VO-236          |
| 31 | DRAIN HOUSING                       | 1   | X375            |
| 32 | DRAIN VALVE                         | 1   | X382            |
| 34 | O-RING-130                          | 1   | VO-130          |
| 35 | 1/4-28 X 3/8 SOCKET SET SCREW       | 2   | VT25-28SS375    |
| 36 | HEADED BUSHING                      | 1   | Y4141           |
| 37 | SPACER                              | 1   | Y4150           |
| 38 | SPACER WASHER                       | 1   | VW97X595-048    |
| 39 | SMALLEY RING                        | 1   | VR4365          |
| 40 | O-RING-241                          | 1   | VO-241          |
| 41 | 5/16" SS BALL (38) PER RACE         | 39  | VB.312          |
| 42 | ELBOW ALUM 2.5"                     | 1   | X333*           |
| 43 | MONITOR CONTROL BOX SHELL SUBASSY.  | 1   | SEE SECTION 9.8 |
| 44 | BOX BRACKET                         | 1   | X390            |
| 45 | CABLE - POWER & COMM.               | 34' | Y5200           |
| 46 | UPPER WIRE SKIRT                    | 1   | Y4650           |
| 47 | LOWER WIRE SKIRT                    | 1   | Y4660           |
| 48 | LOOP CLAMP 3/8"                     | 2   | Y4655           |
| 49 | FLANGE 3"ANSI150 X CODE-RLM         | 1   | Y4410A          |
| 51 | WIRE SKIRT RETAINER                 | 2   | Y4661           |
| 52 | 4" MONITOR BASE CLAMP               | 2   | Y4435           |
|    | 3" MONITOR BASE CLAMP               |     | Y4436           |
| 53 | WASHER                              | 2   | VW360X200-04    |
| 54 | 10-24 X 1 1/4 SOCKET HEAD SCREW     | 2   | VT10-24SH1.2    |
| 55 | CYLINDER NUT                        | 2   | Y4437           |
| 56 | 3/8-24 X 5/16 SOCKET SET SCREW      | 2   | VT37F24SS312    |
| 57 | 10-32 X 1/4 SOCKET SET SCREW        | 1   | VT10-32SS250    |

\* - CONSULT FACTORY FOR SPECIAL THREADS

## 9.6 ELEVATION CHAIN DRIVE ASSEMBLY

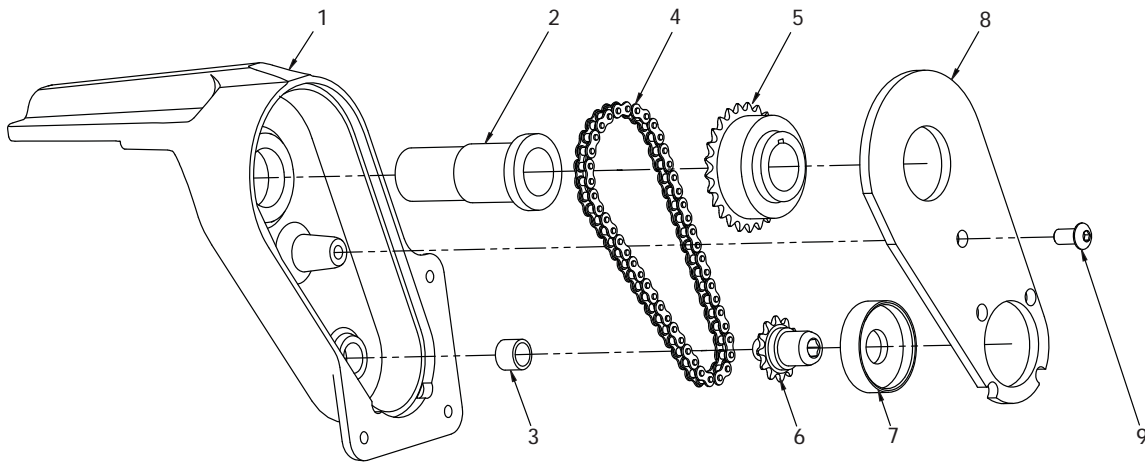

| # | DESCRIPTION       | QTY | PART #       |
|---|-------------------|-----|--------------|
| 1 | HOUSING           | 1   | X250         |
| 2 | BUSHING - SHAFT   | 1   | X251         |
| 3 | BUSHING - DRIVE   | 1   | X252         |
| 4 | ROLLER CHAIN RING | 1   | X255         |
| 5 | SPROCKET - SLAVE  | 1   | X254         |
| 6 | SPROCKET - DRIVE  | 1   | X253         |
| 7 | BUSHING - MOTOR   | 1   | X256         |
| 8 | COVER             | 1   | X257         |
| 9 | 1/4-28 x 1/2 BHCS | 1   | VT25-28BH500 |

## 9.7 GEAR MOTOR ASSEMBLY

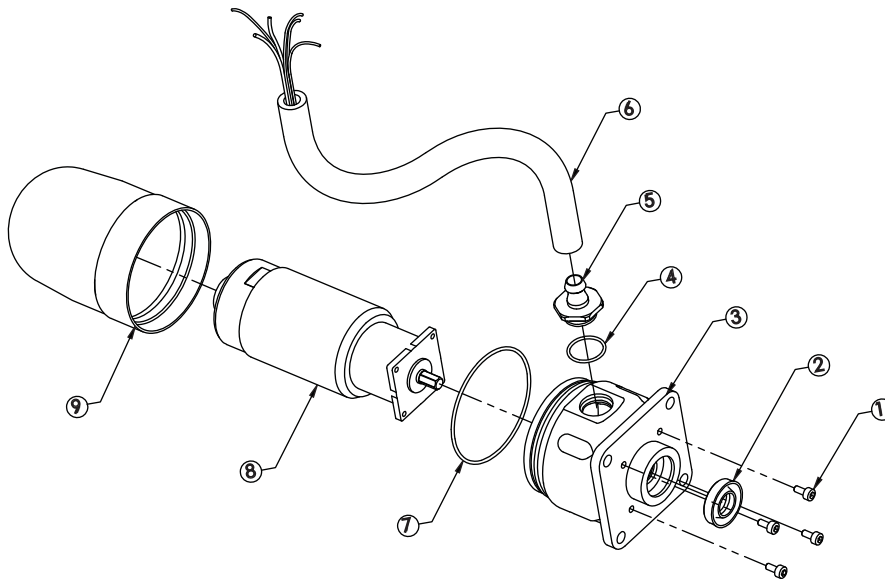

| # | DESCRIPTION                          | QTY | PART #       |
|---|--------------------------------------|-----|--------------|
| 1 | 6-32 x 5/16 LONG SHCS WITH HEAD SEAL | 4   | VT06S32SH312 |
| 2 | CUP SEAL 1.0625 x .5625 x 1/4        | 1   | Y4620        |
| 3 | MOTOR SOCKET                         | 1   | Y4615        |
| 4 | O-RING-018                           | 1   | VO-018       |
| 5 | CONDUIT FITTING                      | 1   | Y5213        |
| 6 | HOSE - 3/8" ID PUSH-LOK              | 1   | Y5250        |
| 7 | O-RING-038                           | 1   | VO-038       |
| 8 | GEAR MOTOR WITH ENCODER              | 1   | Y4611        |
| 9 | ENCLOSURE                            | 1   | Y4616        |

## 9.8 MONITOR CONTROL BOX ASSEMBLY

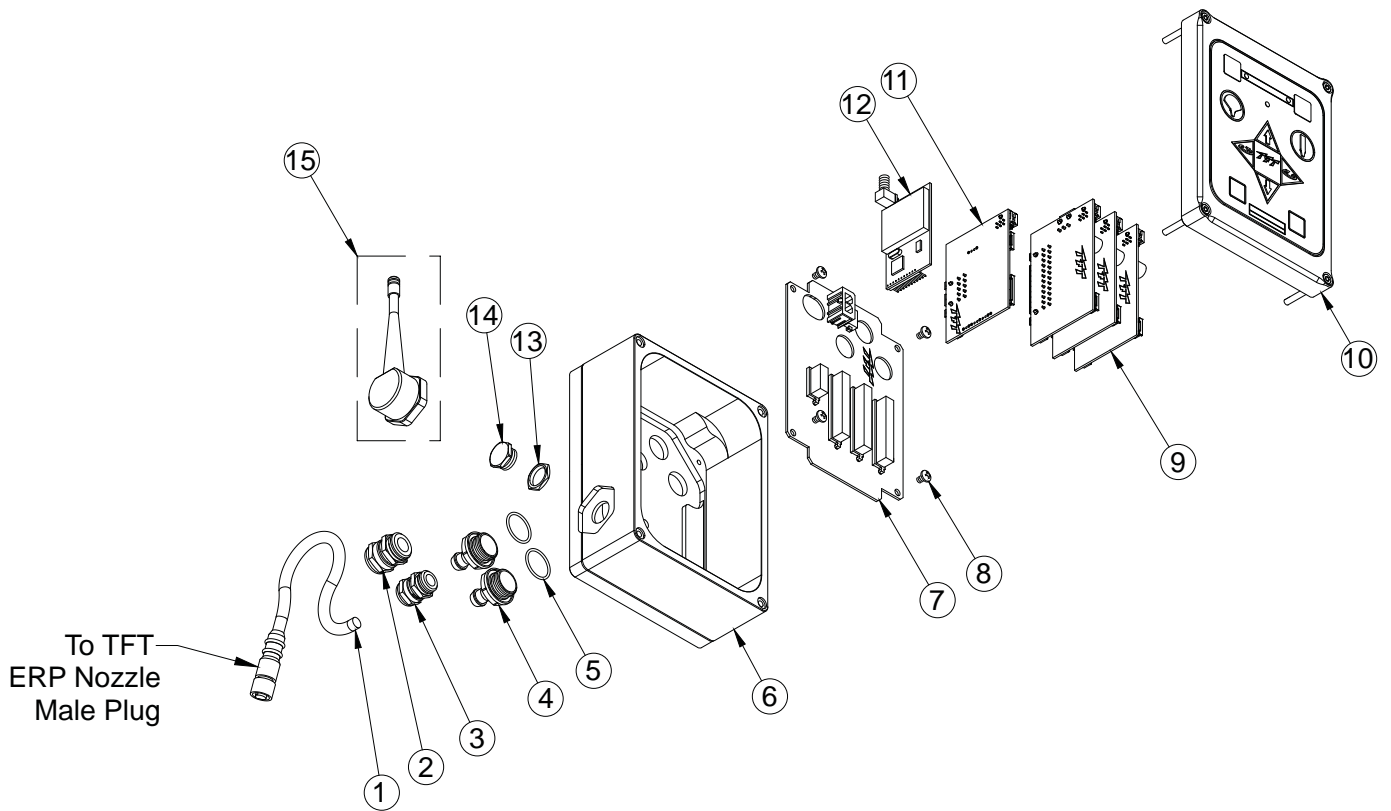

| #   | DESCRIPTION                                    | QTY                                      | PART #      |
|-----|--|--|-------------|
| 1   | CABLE - 6 POLE FEMALE PLUG                     | 10" TOTAL LENGTH USED                    | Y5475       |
|     | FOR HURRICANE RC NOZZLE CONNECTION             | 5" EXPOSED CABLE<br>(NOT INCLUDING PLUG) |             |
| 2   | PG11 STRAIN RELIEF                             | 1  | Y5205       |
| 3   | PG9 STRAIN RELIEF                              | 1  | Y5245       |
| 4   | CONDUIT FITTING                                | 2  | Y5213       |
| 5   | O-RING-018                                     | 2  | VO-018      |
| 6   | ENCLOSURE BOX                                  | 1  | Y5116B      |
| 7   | MAIN BOARD                                     | 1  | Y5105       |
| 8   | M4-0.7 X 6MM PHILLIPS HEAD SCREW               | 4  | VTM4-0.7PH6 |
| 9   | MOTOR CONTROL BOARD                            | 3  | Y5100       |
| 10  | MONITOR CONTROL BOX SHELL - SUBASSEMBLY        | 1  | Y5801-LID   |
| 11  | COMMUNICATION BOARD                            | 1  | Y5110-B     |
| 12  | BOARD - OEM 2.4 GHZ RF MODULE                  | 1  | Y5711       |
|     | BOARD - 900 MHz RF MODULE                      |  | Y5891       |
| 13  | PG9 LOCKNUT                                    | 1  | Y5246       |
| 14  | PG9 HEX PLUG                                   | 1  | Y5248       |
| *15 | 900/920 MHZ ANTENNA W/FITTING & CONN. SUBASSY. | 1  | Y5897       |
|     | 2.4 GHZ ANTENNA ADAPTER W/CONN. SUBASSY.       |  | Y5898       |
|     | * Optional                                     |  |             |

## 10.0 WARRANTY

Task Force Tips, Inc., 3701 Innovation Way, Valparaiso, Indiana 46383-9327 ("TFT") warrants to the original purchaser of its Hurricane and Hurricane RC Monitor ("equipment"), and to anyone to whom it is transferred, that the equipment shall be free from defects in material and workmanship during the five (5) year period from the date of purchase.

TFT's obligation under this warranty is specifically limited to replacing or repairing the equipment (or its parts) which are shown by TFT's examination to be in a defective condition attributable to TFT. To qualify for this limited warranty, the claimant must return the equipment to TFT, at 3701 Innovation Way, Valparaiso, Indiana 46383-9327, within a reasonable time after discovery of the defect. TFT will examine the equipment. If TFT determines that there is a defect attributable to it, it will correct the problem within a reasonable time. If the equipment is covered by this limited warranty, TFT will assume the expenses of repair.

If any defect attributable to TFT under this limited warranty cannot be reasonably cured by repair or replacement, TFT may elect to refund the purchase price of the equipment, less reasonable depreciation, in complete discharge of its obligations under this limited warranty. If TFT makes this election, claimant shall return the equipment to TFT free and clear of any liens and encumbrances.

This is a limited warranty. The original purchaser of the equipment, any person to whom it is transferred, and any person who is an intended or unintended beneficiary of the equipment, shall not be entitled to recover from TFT any consequential or incidental damages for injury to person and/or property resulting from any defective equipment manufactured or assembled by TFT. It is agreed and understood that the price stated for the equipment is in part consideration for limiting TFT's liability. Some states do not allow the exclusion or limitation of incidental or consequential damages, so the above may not apply to you.

TFT shall have no obligation under this limited warranty if the equipment is, or has been, misused or neglected (including failure to provide reasonable maintenance) or if there have been accidents to the equipment or if it has been repaired or altered by someone else.

THIS IS A LIMITED EXPRESS WARRANTY ONLY. TFT EXPRESSLY DISCLAIMS WITH RESPECT TO THE EQUIPMENT ALL IMPLIED WARRANTIES OF MERCHANTABILITY AND ALL IMPLIED WARRANTIES OF FITNESS FOR A PARTICULAR PURPOSE. THERE IS NO WARRANTY OF ANY NATURE MADE BY TFT BEYOND THAT STATED IN THE DOCUMENT.

This limited warranty gives you specific legal rights, and you may also have other rights which vary from state to state.