



MANUAL: Remote Control HURRICANE RC MONITOR

INSTRUCTIONS FOR INSTALLATION, SAFE OPERATION AND MAINTENANCE

⚠ DANGER

Read instruction manual before use. Operation of this device without understanding the manual and receiving proper training is a misuse of this equipment. A person who has not read and understood all operating and safety instructions is not qualified to operate the Hurricane RC monitor.

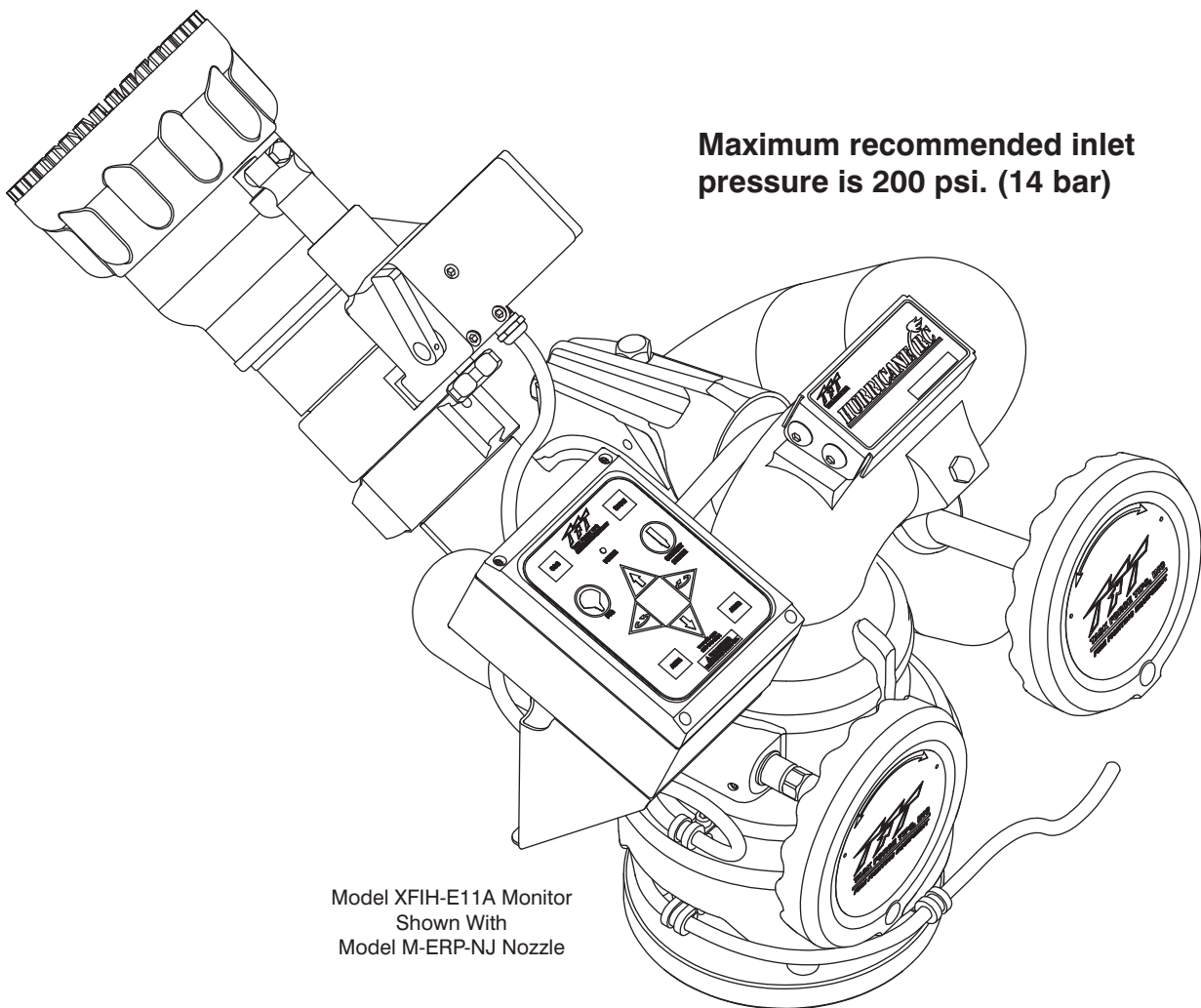

Maximum recommended inlet
pressure is 200 psi. (14 bar)

Model XFIH-E11A Monitor
Shown With
Model M-ERP-NJ Nozzle

This instruction manual is intended to familiarize installers, firefighters and maintenance personnel with the installation, operation, servicing, and safety procedures associated with the Hurricane RC Monitor. This manual should be kept available to all operating and maintenance personnel.

TASK FORCE TIPS, Inc.
MADE IN USA • www.tft.com

2800 E. Evans Ave., Valparaiso, IN 46383-6940 USA
800-348-2686 • 219-462-6161 • Fax 219-464-7155

Table of Contents

<p>1.0 MEANING OF SAFETY SIGNAL WORDS 3</p> <p>2.0 SAFETY 3</p> <p>3.0 GENERAL INFORMATION 3</p> <p> 3.1 SPECIFICATIONS 3-4</p> <p> 3.1.1 MECHANICAL SPECIFICATIONS</p> <p> 3.1.2 ELECTRICAL SPECIFICATIONS</p> <p> 3.2 PART IDENTIFICATION AND MODELS 4</p> <p> 3.3 INLETS AND OUTLETS 5-6</p> <p> 3.3.1 INLET FLANGE SIZE SPECIFICATIONS</p> <p> 3.4 OVERALL DIMENSIONS 6</p> <p> 3.4.1 OVERALL HEIGHT INCREASE FOR INLET FITTINGS</p> <p> 3.5 ELECTRICAL CONTROLS 7</p> <p> 3.5.1 MOTOR CONTROL BOARD (MCB) AUTO CONFIGURE</p> <p> 3.5.2 MOTOR CURRENT LIMITING</p> <p> 3.5.3 MOTOR SOFT STOPS</p> <p> 3.5.4 MOTOR SLOW/FAST SPEED</p> <p> 3.5.5 COMMUNICATION PROTOCOL</p> <p> 3.5.6 OSCILLATE AND STOW FEATURES</p> <p>4.0 INSTALLATION 7-8</p> <p> 4.1 STRUCTURAL REQUIREMENTS FOR MONITOR MOUNTING 7</p> <p> 4.2 INLET FITTINGS or EXTEND-A-GUN RC INSTALLATION 8-9</p> <p> 4.3 NOZZLE CONNECTION 10</p> <p> 4.4 HORIZONTAL ROTATION TRAVEL STOPS 10-11</p> <p> 4.5 PRESSURE GAGE PORT 11</p> <p> 4.6 AUTOMATIC DRAIN 11</p> <p>5.0 ELECTRICAL CONTROLS INSTALLATION 12</p> <p> 5.1 PRIMARY MONITOR OPERATOR STATION 13-14</p> <p> 5.1.1 MOUNTING</p> <p> 5.1.2 ELECTRICAL WIRING</p> <p> 5.2 OPTIONAL MONITOR OPERATOR STATIONS 15</p> <p> 5.2.1 MOUNTING</p> <p> 5.2.2 ELECTRICAL WIRING</p> <p> 5.3 TETHER MONITOR OPERATOR STATION 15-16</p> <p> 5.3.1 HOLSTER MOUNTING</p> <p> 5.3.2 RECEPTACLE MOUNTING</p> <p> 5.3.3 ELECTRICAL WIRING</p> <p> 5.4 WIRELESS MONITOR OPERATOR STATION 16</p> <p> 5.4.1 MOUNTING RECEIVER</p> <p> 5.4.2 ELECTRICAL WIRING RECEIVER</p> <p> 5.4.3 MOUNTING CHARGING CRADLE</p> <p> 5.4.4 ELECTRICAL WIRING CHARGING CRADLE</p> <p> 5.5 JOYSTICK MONITOR OPERATOR STATION 17-18</p> <p> 5.5.1 MOUNTING</p> <p> 5.5.2 ELECTRICAL WIRING</p> <p> 5.5.2.1 WIRING TO A COMMUNICATION INTERFACE BOX</p> <p> 5.5.2.2 WIRING TO PRIMARY OPERATOR STATION</p> <p> 5.6 TOGGLE SWITCH MONITOR OPERATOR STATION 18</p> <p> 5.6.1 ENCLOSURE MOUNTING</p> <p> 5.6.2 ELECTRICAL WIRING</p> <p> 5.7 COMMUNICATION INTERFACE BOX 19</p> <p> 5.7.1 ENCLOSURE MOUNTING</p> <p> 5.7.2 ELECTRICAL WIRING</p> <p> 5.7.3 INPUT SIGNAL CONFIGURATION</p> <p> 5.8 MONITOR POSITION DISPLAY 19</p> <p> 5.9 CONNECTING MONITOR CABLE DIRECTLY TO PROTECTED POWER SUPPLY 19</p>	<p> 5.9.1 ELECTRICAL WIRING</p> <p>5.10 OPERATOR STATION INSTALLATION DIRECTLY TO MONITOR ... 20</p> <p>5.11 HURRICANE RC AERIAL TRUCK INSTALLATION 20-21</p> <p> 5.11.1 ELECTRONICS ENCLOSURE MOUNTING</p> <p> 5.11.2 ELECTRICAL WIRING</p> <p> 5.11.2.1 LADDER INSTALLATION ELECTRICAL WIRING</p> <p> 5.11.2.2 PLATFORM INSTALLATION ELECTRICAL WIRING</p> <p>5.12 ELECTRICAL NOZZLE ACTUATOR WIRING 21</p> <p>6.0 OPERATION 21</p> <p>6.1 MANUAL OVERRIDE HANDWHEELS 22</p> <p>6.2 ELECTRICAL MODEL 22-24</p> <p> 6.2.1 OPERATOR STATIONS</p> <p> 6.2.1.1 MONITOR MOUNTED OPERATOR STATION</p> <p> 6.2.1.2 PRIMARY OPERATOR STATION</p> <p> 6.2.1.3 OPTIONAL OPERATOR STATION</p> <p> 6.2.1.4 TETHER OPERATOR STATION</p> <p> 6.2.1.5 WIRELESS OPERATOR STATION</p> <p> 6.2.1.6 JOYSTICK OPERATOR STATION</p> <p> 6.2.1.7 TOGGLE SWITCH OPERATOR STATION</p> <p> 6.2.2 MASTER OVERRIDE FEATURE</p> <p>6.2.3 STOW FEATURE</p> <p> 6.2.3.1 PROGRAMMING</p> <p> 6.2.3.2 STOW PROGRAMMING EXAMPLE</p> <p>6.2.4 OSCILLATE FEATURE</p> <p> 6.2.4.1 PROGRAMMING</p> <p> 6.2.4.2 OSCILLATE PROGRAM RETAIN FEATURE</p> <p>6.2.5 OPERATOR STATION PANELS</p> <p>6.3 RECOMMENDED MONITOR STOWING POSITION 25</p> <p>6.4 AUTOMATIC DRAIN 25</p> <p>6.5 FLOWS & PRESSURES 25-29</p> <p> 6.5.1 STACKED TIPS FLOW AND REACH</p> <p> 6.5.2 AUTOMATIC NOZZLES</p> <p> 6.5.3 HURRICANE RC MONITOR FRICTION LOSS</p> <p>6.6 STREAM STRAIGHTENERS 29</p> <p> 6.6.1 STREAM STRAIGHTENERS WITH STACKED TIP NOZZLES</p> <p> 6.6.2 STREAM STRAIGHTENERS WITH FOG NOZZLES</p> <p>7.0 TROUBLESHOOTING 30</p> <p>8.0 MAINTENANCE AND INSPECTION 31</p> <p>8.1 LUBRICATION 31</p> <p> 8.1.1 ELEVATION CONTROL WORM GEAR</p> <p> 8.1.2 HORIZONTAL ROTATION WORM GEAR</p> <p>8.2 PERFORMANCE TESTING 31</p> <p>9.0 EXPLODED VIEW DRAWINGS AND PARTS LIST 32-35</p> <p> 9.1 HURRICANE RC MONITOR ASSEMBLY 32-33</p> <p> 9.2 ELEVATION CHAIN DRIVE ASSEMBLY 34</p> <p> 9.3 GEAR MOTOR ASSEMBLY 34</p> <p> 9.4 MONITOR CONTROL BOX ASSEMBLY 35</p> <p>10.0 WARRANTY Back Cover</p>
--	---

1.0 MEANING OF SAFETY SIGNAL WORDS

A safety related message is identified by a safety alert symbol and a signal word to indicate the level of risk involved with a particular hazard. Per ANSI standard Z535.4-1998, the definitions of the three signal words are as follows:



DANGER indicates an imminently hazardous situation which, if not avoided, will result in death or serious injury.



WARNING indicates a potentially hazardous situation which, if not avoided, could result in death or serious injury.



CAUTION indicates a potentially hazardous situation which, if not avoided, may result in minor or moderate injury.

2.0 SAFETY

The operation of this monitor can be dangerous. The following must be observed at all times.



Injury can result from an inadequately supported monitor. The monitor mount must be capable of supporting 1500 lbs (700 kg) of nozzle reaction force.



The stream exiting a monitor is very powerful and capable of causing injury and property damage. Make sure the monitor is securely attached to the base and pointing in a safe direction before water to the monitor is turned on. Use care in directing the stream.



The electric Hurricane RC may be remotely operated. The electric drives are current limited but may still produce enough force to cause injury. Keep hands and fingers away from pinch points on the monitor.



Do not use the manual override handwheels while the electric controls are in operation. The electric drives produce enough torque to cause injury.



Maximum pressure is 200 psi (14 bar). Damage or injury may result if the monitor is operated beyond these limits.

On many vehicle installations the monitor is the highest point on the apparatus. Often it is critical that the monitor be properly stowed before driving to avoid damage to overhead obstructions such as door openings. In these cases the use of a switch wired into the apparatus "door open" circuit is highly recommended. The switch should be wired to give a "door open" signal if the monitor is not in the stowed position. Due to the variety of possible mountings and nozzles, it is the installer's responsibility to supply the appropriate switch with mounting and wire it into the system. Always check stowed position of the monitor before moving the apparatus.

3.0 GENERAL INFORMATION

The Task Force Tips' HURRICANE RC is an electric remote monitor, with a single low-profile waterway discharge. It has high flow and low friction loss characteristics. Capable of flowing 1250 gpm (4500 l/min) while maintaining a FULL 450° of rotational travel (225° either side of center position). Maximum operating pressure is 200 psi (14 bar). Field changeable horizontal rotation stops at 45°, 90° and 135° either side of center position. Elevation range is 90° above horizontal and 45° below. Designed for field changeable 12 or 24 VDC operation. The Hurricane RC comes with a factory installed control panel mounted on the monitor for controlling horizontal rotation, elevation and nozzle pattern. See Task Force Tips' Price List and Product Specifications for additional control stations. Unit comes with 30 feet of ultra-flexing robotic cable, enclosed in a unique wire guide, already wired to the monitor so installation effort is minimized. Large handwheels are provided on the horizontal rotation and elevation drive for manual override. TFT's Master Stream 1250 nozzle plugs into the factory installed nozzle power wire. All electrical components affecting water tightness are a minimum of NEMA 4 (IP65). Motors and control boxes are factory tested for water tightness. Available with various inlet adapters for flanges and thread fittings. Inlet also made for direct connection to TFT's Extend-A-Gun RC3 or RC4. Standard outlet is 2-1/2" National Hose male (65mm). Other outlets are available (see figure 3.3). A threaded port (0.25" NPT) (6.4mm) is provided for pressure gauge. The monitor is made from hardcoat anodized ANSI 356.0-T6 aluminum and silver powder coat finish inside and out.

3.1 SPECIFICATIONS

3.1.1 MECHANICAL SPECIFICATIONS

Weight	39 lbs	17.7 kg
Min. Flow Area	7.07 in ²	45.6 cm ² - 3" inlets
Max Flow	1250 gpm	4500 l/min
Max Operating Pressure	200 psi	14 bar
Materials Used	ANSI 356.0-T6 Aluminum, Stainless, Nylon	

3.1.2 ELECTRICAL SPECIFICATIONS

Nominal Operating voltage:	12 or 24 VDC (field changable)	
Motor current:	Nominal*	Limit
Elevation motor:	6 amps	15 amps
Horizontal rotation motor:	6 amps	10 amps
Nozzle motor:	1 amp	5 amps
	*with rated water pressure applied	
At rest current:	.25 amps	
Recommended fuse or circuit breaker size:	15 amps @ 12 volts, 7.5 amps @ 24 volts	
Operating temperature range:	-30°F to +120°F (-34°C to +49°C)	
Environmental Rating:	All components designed to meet minimum rating of NEMA 4 (IP65).	

Wireless Operator Station

Charging Cradle	
Nominal Operating Voltage	12 or 24 VDC
Operating Current	0.15 amps
Recommended Fuse or Circuit Breaker	2 amps
Transmitter Batteries	Uses four (4) AA NiCad Batteries
Transmitter Power	5mW
Operating Frequency	2.4 GHz
Agency Approvals	FCC Part 15 - United States
	ISC - Canada
	CE - European Union

3.2 PART IDENTIFICATION AND MODELS

The Hurricane RC Monitor as shown in Figure 3.2 along with the names of some various parts and controls.

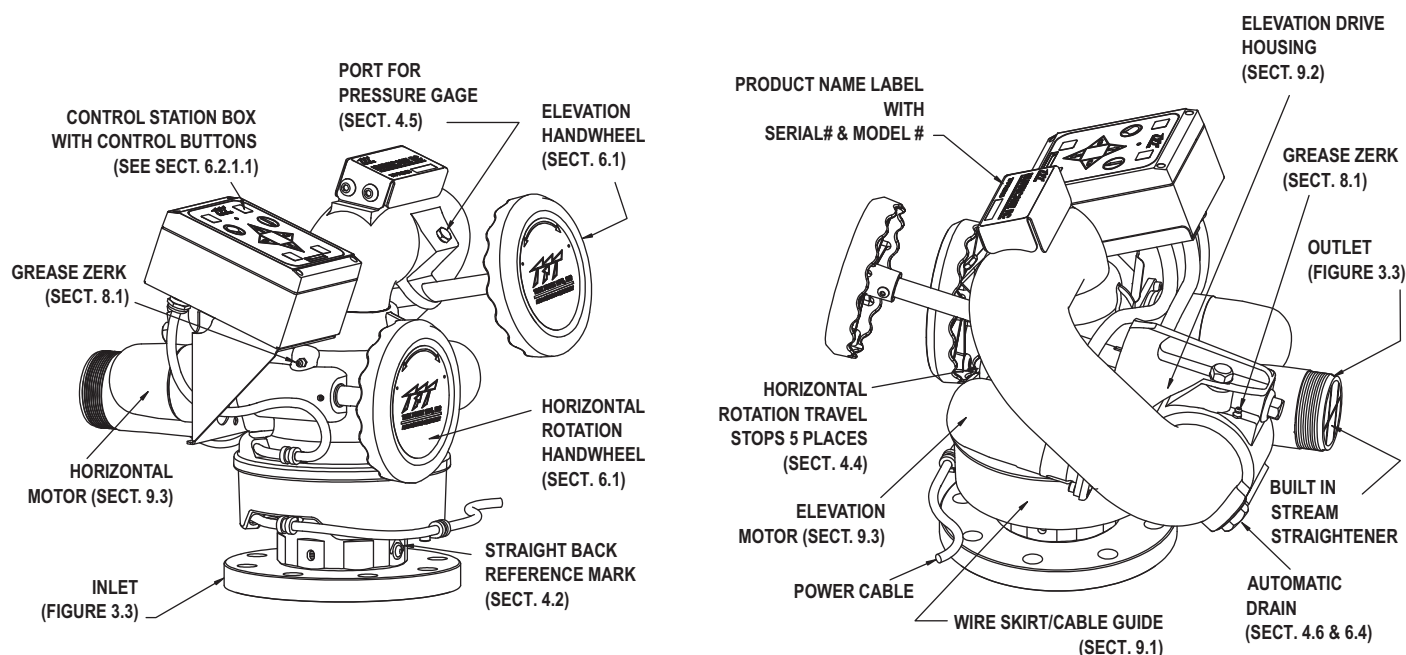

FIG 3.2
Part Identification

3.3 INLETS AND OUTLETS

The standard Hurricane RC Monitor inlet is CODE-RLF for direct connection to TFT's Extend-A-Gun RC3. Monitor inlet CODE-RPF is available for direct connection to Extend-A-Gun RC4. The standard outlet is 2-1/2"-6 National Hose male. Various other inlet and outlet fittings are available as shown in Figure 3.3.

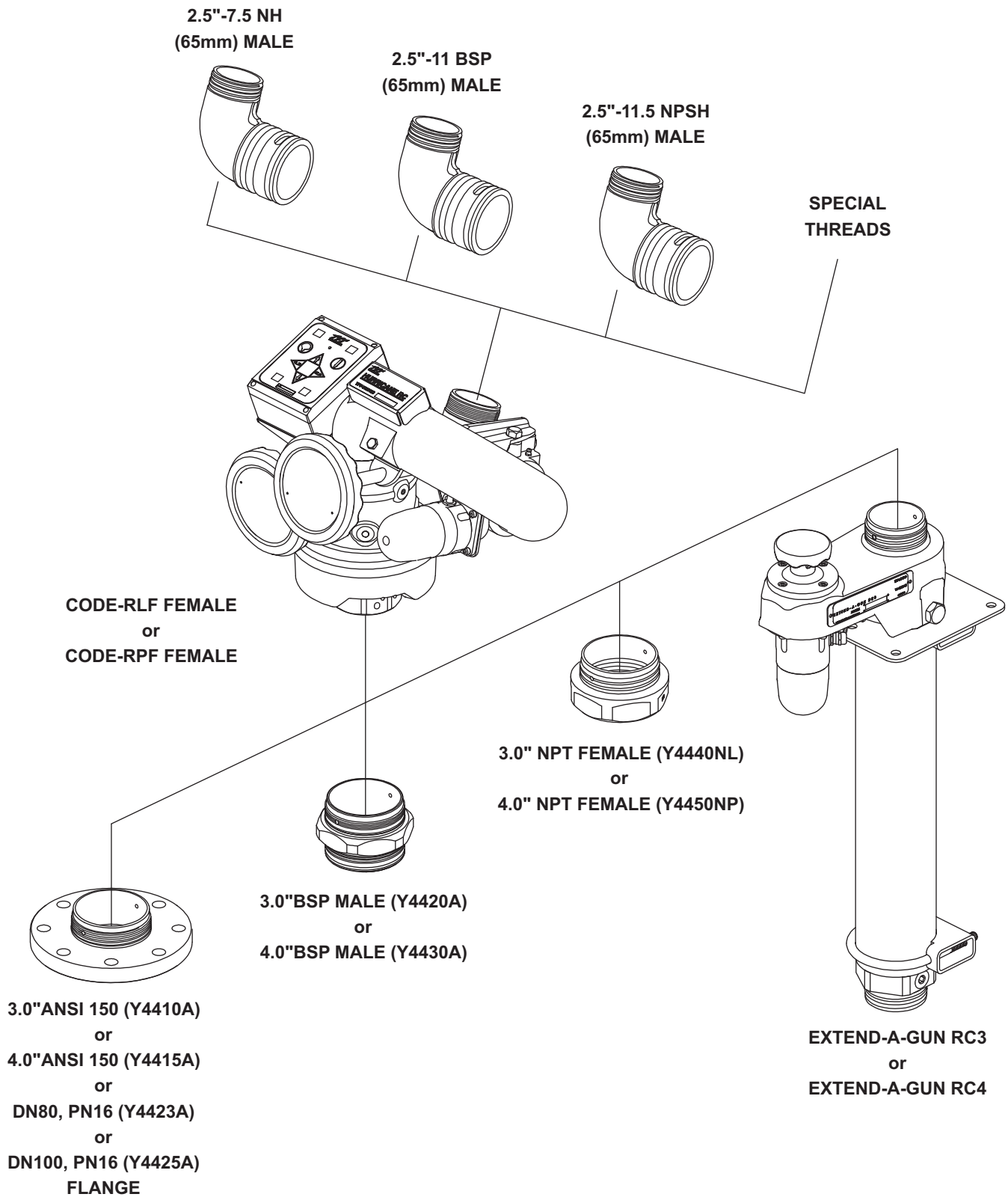

FIG 3.3
Inlets And Outlets

3.3.1 INLET FLANGE SIZE SPECIFICATIONS

MODEL	FITS FLANGE	OUTSIDE DIAMETER	THICKNESS	BOLT HOLE CIRCLE	NO. BOLT HOLES	SIZE OF BOLTS	TORQUE ON BOLTS
XFIH-E1*A	3" ANSI 125/150 (metric DN8 PN20)	7.5" 190mm	.75" 20mm	6.0" 152.5mm	4 4	5/8" M16	76-80 FT-LBF 100-110 Newton Meters
XFIH-E2*A	4" ANSI 150 (metric DN100 PN20)	9.0" 230mm	.94" 23mm	7.5" 190.2mm	8 8	5/8" M16	76-80 FT-LBF 100-110 Newton Meters
XFIH-E4*A	metric DN80, PN16	200 mm	22 mm	160 mm	8	16 mm	100-110 Newton Meters
XFIH-E5*A	metric DN100, PN16	220mm	22 mm	180 mm	8	16 mm	100-110 Newton Meters

* The second to last digit in the model number refers to exit thread size and type.

3.4 OVERALL DIMENSIONS

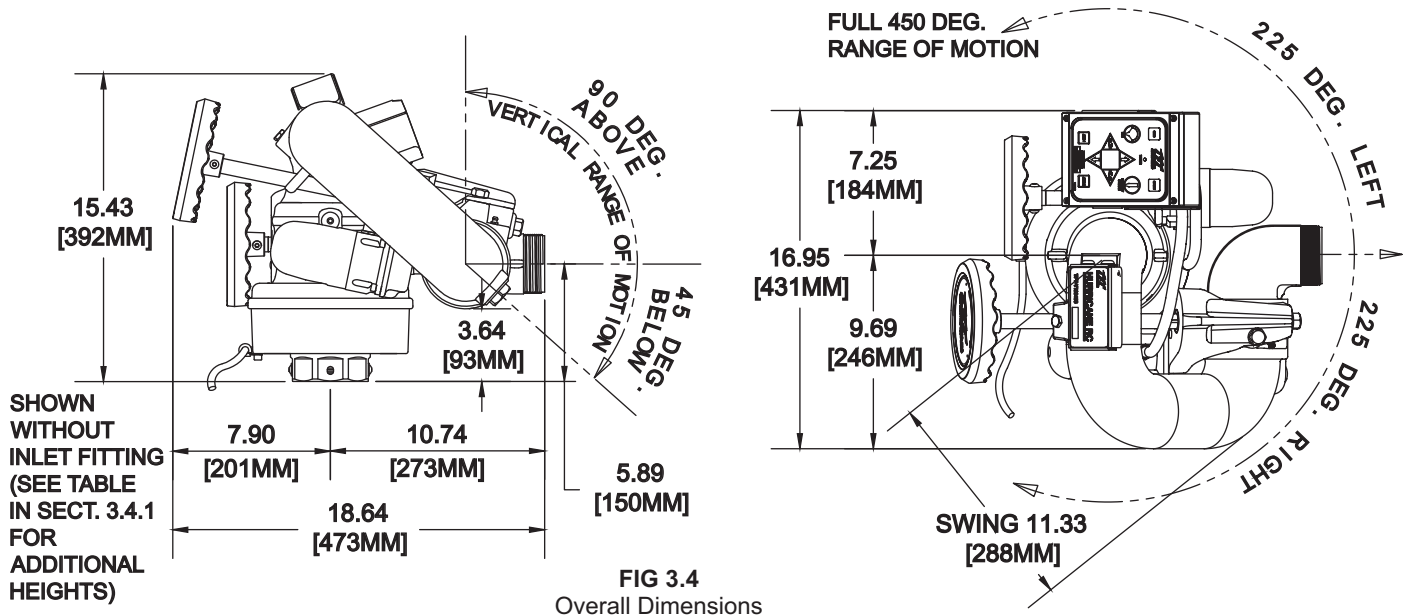

3.4.1 OVERALL HEIGHT INCREASE FOR INLET FITTINGS

MODEL	INLET FITTING TYPE	ADDITIONAL HEIGHT	OVERALL HEIGHT
XFIH-E1*A	3" ANSI 125/150 (metric DN8 PN20)	.75" 20 mm	16.18" 412 mm
XFIH-E2*A	4" ANSI 150 (metric DN100 PN20)	.94" 23 mm	16.37" 415 mm
XFIH-E4*A	metric DN80, PN16	2.80" 22 mm	18.23" 414 mm
XFIH-E5*A	metric DN100, PN16	2.80" 22 mm	18.23" 414 mm
XFIH-E6*A	3" NPT Female	2.00" 51 mm	14.43" 443 mm
XFIH-E7*A	4" NPT Female	1.75" 45 mm	17.18" 436 mm
XFIH-E8*A	3" BSP Male	2.30" 58 mm	17.73" 450 mm
XFIH-E9*A	4" BSP Male	2.30" 58 mm	17.73" 450 mm

* The second to last digit in the model number refers to exit thread size and type.

3.5 ELECTRICAL CONTROLS

The electric Hurricane RC monitor is controlled by a very powerful, state-of-the-art electronics system. The key components of the system are the motor control boards and a communication board. Each motor control board has its own microprocessor and a sophisticated motor control chip. The communication board also has a microprocessor, which handles the interface to the operator stations. All the components on these boards are solid state; there are no relays or electro-mechanical devices to wear out over time. The hardware and software have been designed with several key features:

3.5.1 MOTOR CONTROL BOARD (MCB) AUTO CONFIGURE

Each monitor has three MCBs, one for each motor, which controls motor movement and direction for horizontal rotation, elevation, and nozzle pattern. In the unlikely event of a MCB failure, the failed board can be removed and one of the other two remaining MCBs can be moved into that position. This MCB will then auto configure itself to take over the control of that axis, so that the monitor can continue to be used, with two of the three motors. This is also a helpful benefit when troubleshooting and requires fewer spare parts to be stocked.

3.5.2 MOTOR CURRENT LIMITING

The microprocessor on the MCB continuously monitors the motor current. As the motor reaches an end stop or if there is an obstruction, the motor current rises very quickly and the motor control chip automatically shuts down the motor in a few milliseconds. This eliminates the need for any type of external limit switches and the associated wiring. The microprocessor also locks the operator from moving in the stopped direction again, until the operator first moves in the opposite direction.

3.5.3 MOTOR SOFT STOPS

The horizontal and vertical motors are equipped with feedback encoders, which allow the microprocessor to know the motor position at all times. The first time a motor reaches an end stop or strikes an obstruction, the microprocessor sets a new soft stop position just before the end stop. From that point on, when the axis approaches the stop, the MCB automatically slows down the motor until the end stop is reached. This significantly reduces the wear on the motor, gearbox, and external gears.

3.5.4 MOTOR SLOW/FAST SPEED

When an operator presses one of the buttons, the associated motor starts in slow speed mode so that the operator can accurately control the water stream. After approximately 1-2 seconds the motor automatically ramps up to a fast speed, for quickly moving into position. When quickly changing directions, monitor retains speed from prior move. If low speed is selected, monitor does not ramp to high speed but remains in slow speed.

3.5.5 COMMUNICATION PROTOCOL

The communication from the monitor to the operator stations is performed over two wires using RS-485 serial protocol. Multiple operator stations can be added with only two wires for power and two wires for the RS-485 protocol between each station.

3.5.6 OSCILLATE AND STOW FEATURES

The OSCILLATE feature allows the user to program up to 65 points of continuous movement of the horizontal and vertical axes. The OSCILLATE pattern can be programmed from any operator station that has the OSC button.

The STOW feature allows the user to move the monitor, with one touch of a button, to a safe position before moving the fire truck. The monitor will always move to two end stops to verify the correct position. During the programming procedure, the user has the ability to select which axis moves first. This is helpful to avoid lights, hoses, obstructions, etc. The user can program up to 10 points of movement to reach the final STOW position. The STOW pattern can be programmed from any operator station that has the STOW button.

See section 6.2.3 and 6.2.4 for programming instructions.

4.0 INSTALLATION

4.1 STRUCTURAL REQUIREMENTS FOR MONITOR MOUNTING

The structure that the Hurricane RC Monitor is mounted to must withstand the internal pressure of the monitor as well as shear and bending forces due to nozzle reaction. Nozzle reaction can be as high as 1,050 lbs (480 kg) (1250 gpm at 200 psi).

For flanged connections, the use of flat flanges without raised faces is recommended. Use a full-face gasket as defined in SME 16.21 or ISO 7483. Tighten flange bolts in an alternating sequence as shown in figure 4.1. Tighten to 76-80 ft-lb (100-110 Newton-Meters).

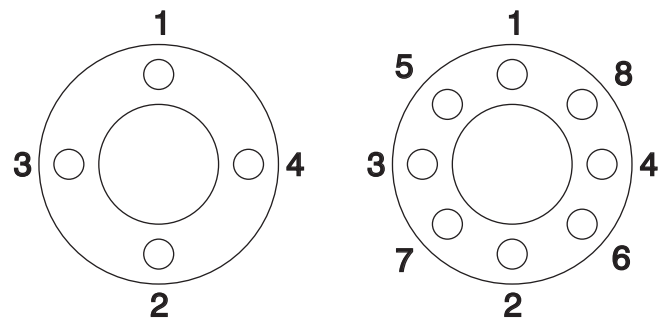

FIG 4.1 - Flange Bolt Tightening Sequence
Tighten sequentially each bolt three times.



Injury can result from an inadequately supported monitor. The monitor mount must be capable of supporting the nozzle reaction force which can be as high as 1500 lbs (700 kg). Flanges and pipe made from plastic are inadequate for monitor mounting and must not be used. This monitor is not recommended for portable use.

4.2 INLET FITTINGS OR EXTEND-A-GUN RC INSTALLATION

The Hurricane RC Monitor is available with various inlet fittings as shown in figure 3.3. The Hurricane RC Monitor also connects directly to TFT's Extend-A-Gun RC3 or RC4. The fittings and Extend-A-Gun RC are attached to the monitor by means of a threaded joint with an o-ring seal. Once in the proper orientation, the threaded joint is locked from rotation by two 1/4-28 button head cap screws as shown in figure 4.2A. This makes for easy removal of the monitor, since the large threads of the joint are not tightened and do not have any thread locking compounds on them. It is best to install the inlet fitting or Extend-A-Gun RC to the apparatus and then install the monitor to the inlet fitting or Extend-A-Gun RC. This gives more room to install the bolts in the case of flanged fittings. Referring to figures 4.2A and 4.2B, the installation sequence is as follows:

- 1) Install inlet adapter or Extend-A-Gun RC to apparatus.
 - Mount so that 180 degree apart threaded cross holes will give desired direction relative to the "Straight Back Reference Mark" when the monitor is installed.
- 2) Screw monitor onto inlet adapter or Extend-A-Gun RC until threaded joint bottoms out.
 - Do not use pipe dope or Loctite on the inlet base threads. These threads are sealed with an o-ring. The use of thread locking compounds will make removal difficult.
- 3) Unscrew monitor slightly until a pair of 90 degrees apart slots line up with the 180 degrees apart threaded cross holes in the inlet adapter or Extend-A-Gun RC.
 - Orient monitor so that the Straight Back Reference Mark is facing the desired direction.
 - Slots will line up with threaded cross holes every 90 degrees of rotation.
 - Monitor may be unscrewed up to one full turn from the bottomed out position.
- 4) Install 1/4-28 by 1/2 long button head cap screws and washers in the two threaded cross holes.

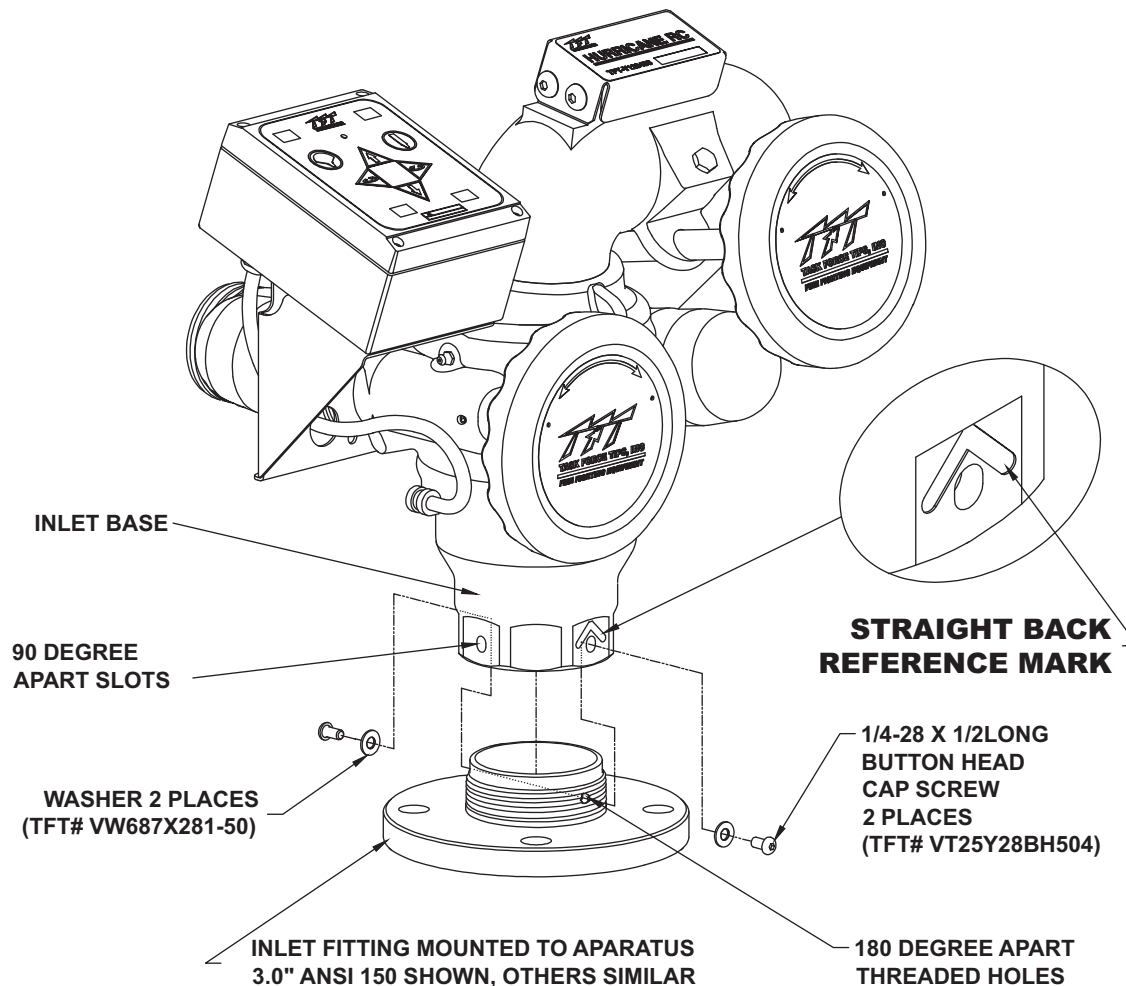

(This view shown without power cable guide for purposes of illustration.)

FIG 4.2A
3" Inlet Fitting Connection

The Extend-A-Gun RC manual override knob may be mounted in any one of four possible orientations (90 degrees apart).

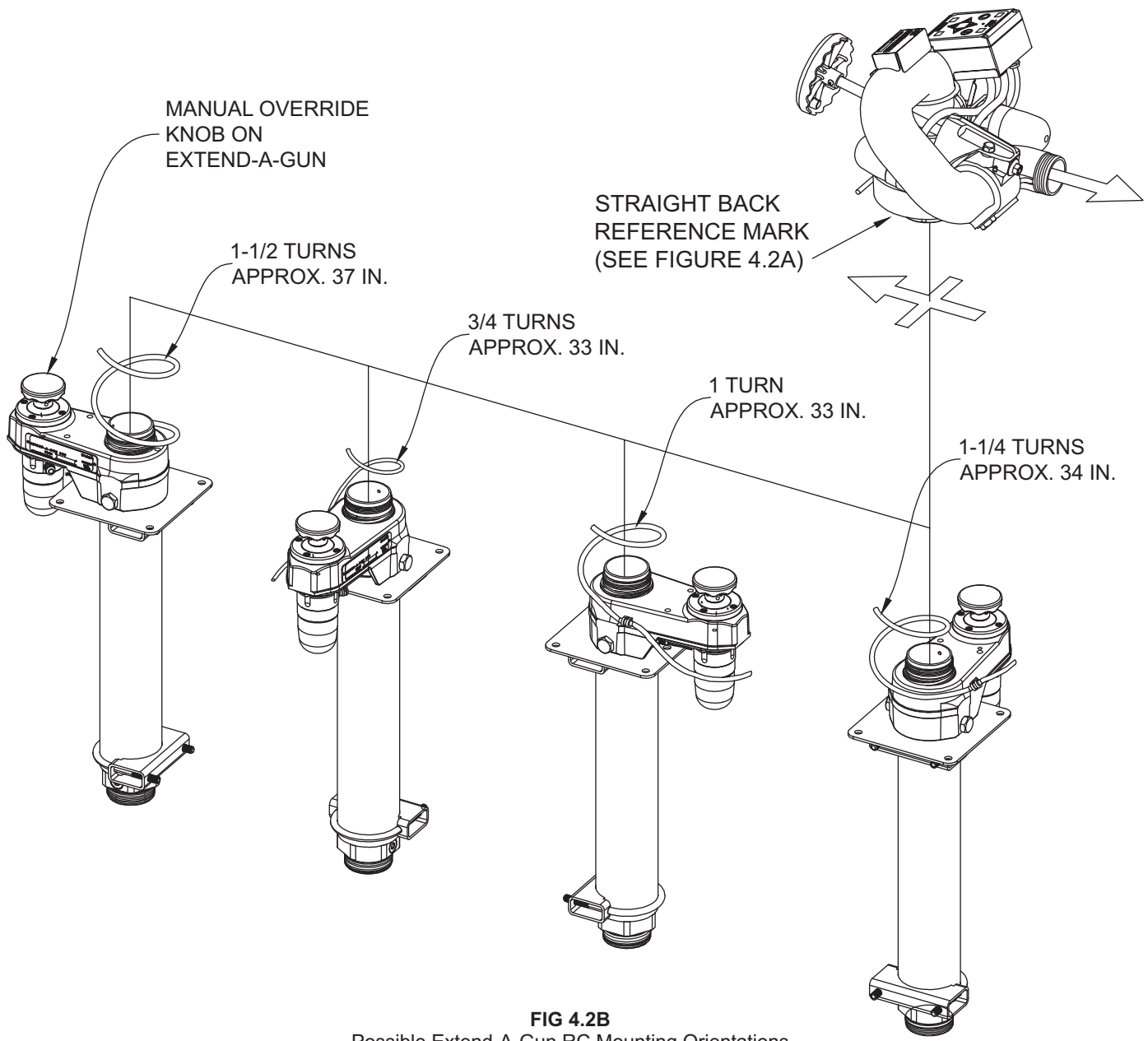

FIG 4.2B
Possible Extend-A-Gun RC Mounting Orientations

The Extend-A-Gun manual override knob may be mounted in any of four possible orientations (90 degrees apart) relative to the Straight Ahead Reference Mark on the monitor.

NOTE: Monsoon monitor, for use with Extend-A-Gun RC, comes with the wire installed in a nylon tube. The nylon tubing gives the wire additional stiffness so it better follows as the Extend-A-Gun RC extends or retracts. A fitting is also supplied and is to be used where the nylon tubing and wire pass through the deck.

4.3 NOZZLE CONNECTION

The Hurricane RC monitor outlet thread types are as shown in figure 3.3. The nozzle is simply screwed onto the Hurricane RC monitor's exit threads. Insure that the nozzle's coupling does not make contact with the elevation drive housing when the monitor is in its highest elevation position.

For nozzles with electric pattern control, a waterproof connector wire is provided at the bottom outlet of the Hurricane RC's control station box. This wire attaches directly to TFT's electric Masterstream 1250 nozzle. The electric actuator box of nozzle must be oriented to the top side of nozzle for the connection wire to extend 90° above horizontal and 45° below elevation movement. (see figure 4.3 and refer to Sections 5.12 and 6.6.2 for properly attaching female to male connectors). Any other nozzle should have the corresponding male electrical connector installed and long enough wire to extend 90° above horizontal and 45° below elevation movement of the nozzle. **DO NOT CUT OFF THE FEMALE CONNECTOR ON THE MONITOR. THIS CONNECTOR IS MOLDED ONTO THE WIRE AND MUST REMAIN ON TO MAINTAIN THE WATER TIGHTNESS OF THE ELECTRICAL SYSTEM.**

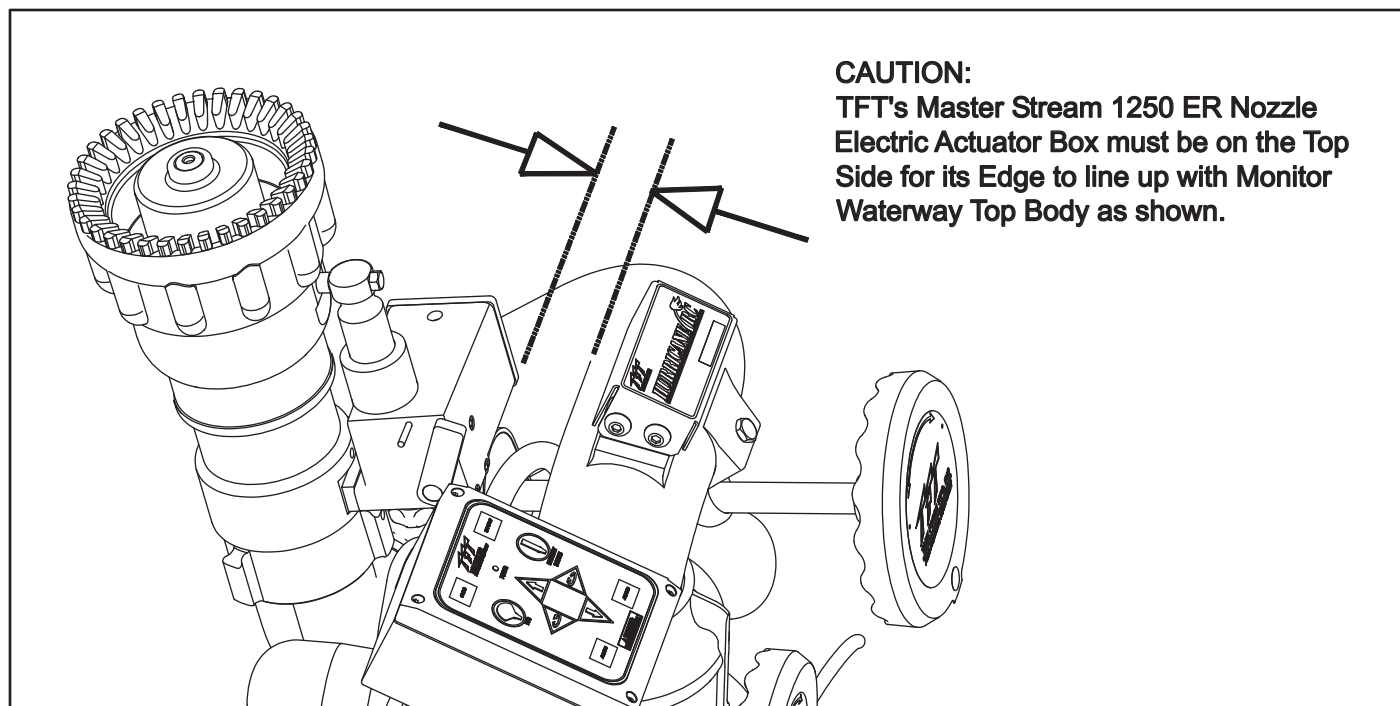

FIG 4.3
Correct ER Nozzle Install Orientation



The nozzle threads must match the threads on the Hurricane RC in both size and type. Mismatched or damaged threads may cause the nozzle to leak or uncouple under pressure and could cause injury.



Do not connect aluminum to brass or brass to aluminum. Dissimilar metals coupled together can cause galvanic corrosion that will freeze the threaded joint or cause complete loss of thread engagement. If dissimilar metals must be coupled together, the effects of corrosion can be greatly delayed by various coatings on the metal such as powder paint, hard anodizing or silicone grease.

4.4 HORIZONTAL ROTATION TRAVEL STOPS

The range of Horizontal (left-right) travel for the Hurricane RC monitor is limited to 450 degrees or 225 degrees from either side of a nozzle discharge position. Horizontal (left-right) travel stop bolts may be installed in the monitor to limit travel as shown in figure 4.4A and 4.4B. Note that left and right are relative to the "Straight Back Reference Mark" shown in figure 4.4A, and refer to the operator's position behind the monitor, opposite the nozzle's discharge direction. Also, Figure 4.4A shows the range of travel for the various stop bolt locations along with installation notes as shown in Figure 4.4B.

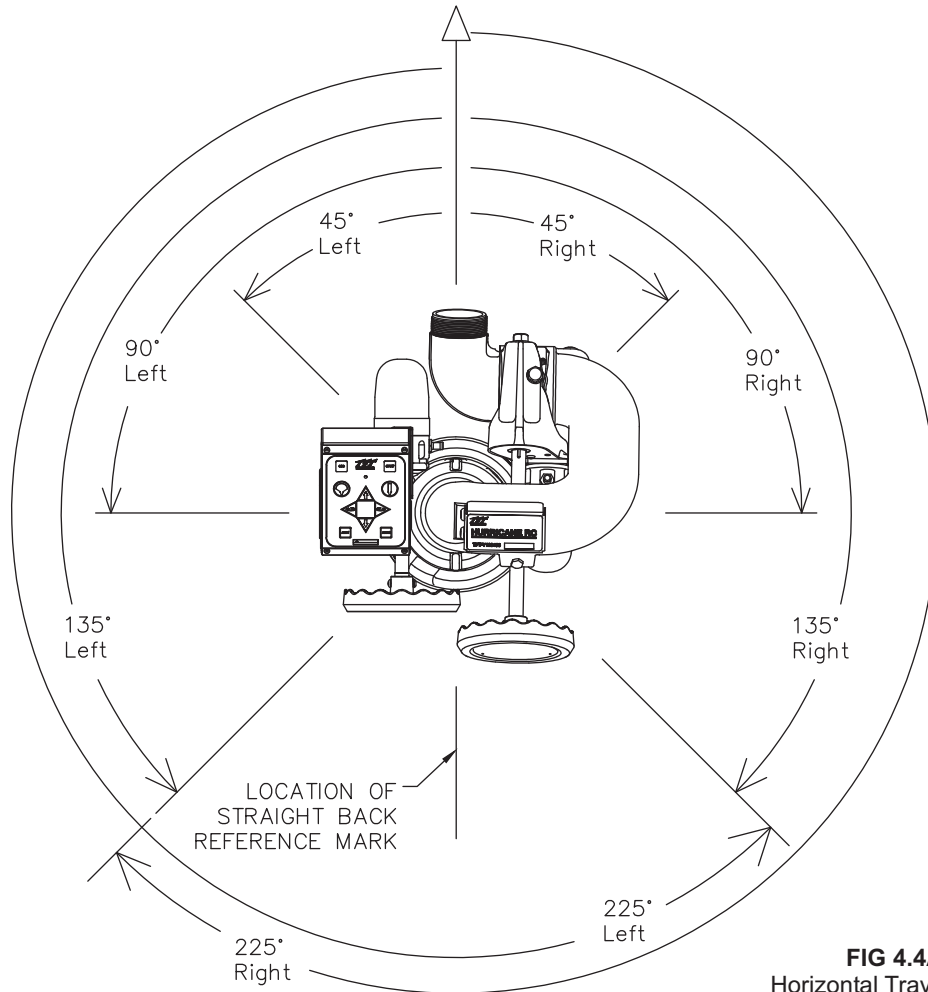

FIG 4.4A
Horizontal Travel Limits

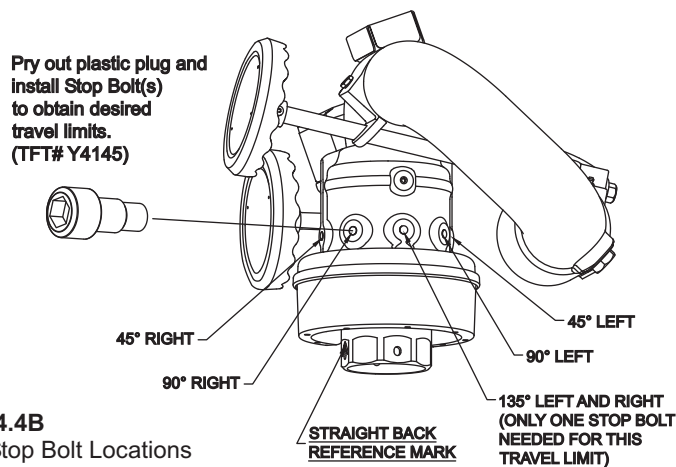

FIG 4.4B
Horizontal Travel Stop Bolt Locations

4.5 PRESSURE GAUGE PORT

There is a 1/4" NPT female threaded hole located behind the elevation hand wheel for the installation of a pressure gauge if desired. This hole has a pipe plug installed from the factory. Unscrew the pipe plug and install the gauge using pipe sealant. Make sure that the gauge does not interfere with the handwheel.

4.6 AUTOMATIC DRAIN

There is an automatic drain on the Hurricane RC installed from factory, that will empty the water from the low point of the lower bend to prevent freezing (Figure 3.2). This valve will close automatically when the internal pressure in the monitor reaches approximately 5 psi (6.3 bar) and will reopen again when the pressure drops to this point. Refer to Section 6.4 for disabling the automatic drain if desired.

A secondary drain valve should be installed on the monitor's inlet piping to drain water in the riser.

5.0 ELECTRICAL CONTROLS INSTALLATION

The electric RC monitor is supplied with a monitor mounted operator station. The wiring on the monitor and for this operator station is factory installed. The assembly is supplied with a 30-foot length of cable for connection to the operator control stations as shown in Figure 5.0 or directly to a protected voltage supply. This cable has 4-conductors which supply power and the communications from the operator stations to the monitor. To complete the installation, the installer will need to mount and wire the selected operator stations. The power supply for the monitor will need to be connected to a protected circuit from the truck's power distribution center. Refer to the specifications section 3.2.1 for nominal current draw.

- Good mechanical connections on the wires are absolutely necessary and should be checked periodically. Poor electrical connections can cause power loss to the electric RC monitor and be a fire hazard.
- Careful selection of wiring is critical to avoid excessive voltage drop.
- Be careful to route cables in a protected area away from high heat sources.
- Use grommets whenever wires pass through holes to prevent damage due to snags, abrasions, etc.
- Secure cables close to control box with plastic wire ties or cable clamps to relieve stress on the cables.
- Disconnect power before installing or servicing the electrical components. The RC monitor control boxes and motors are not rated as ignition proof, explosion proof, or intrinsically safe.



The electric motors and other components are ignition sources. The electric drives should be operated only in areas where there is adequate ventilation and no hazard of flammable vapor buildup.

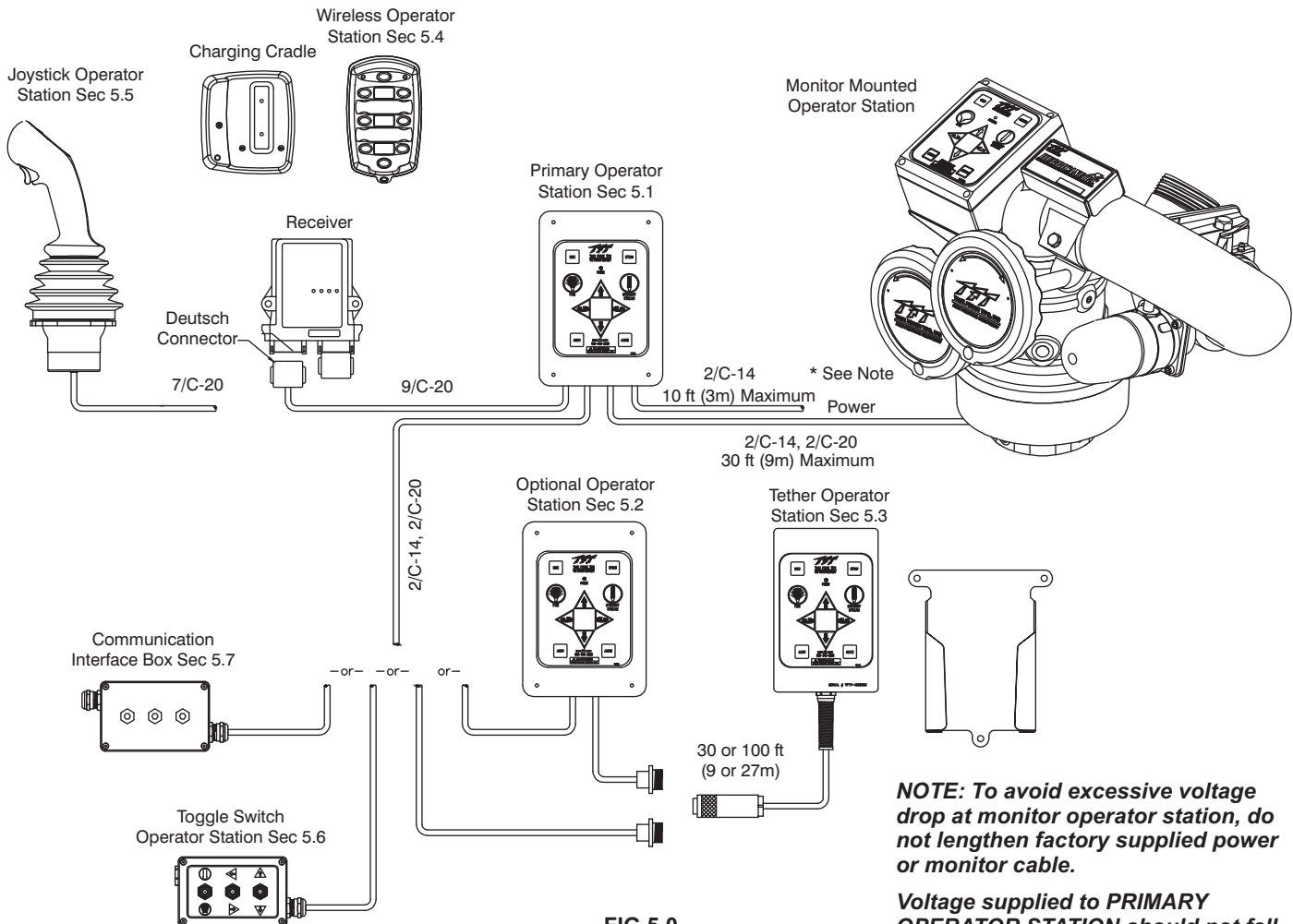

FIG 5.0
Electrical Components
(non-aerial installation)

Recommended Tool List

11/32" nut driver
Wire cutter/stripper
Terminal crimping tool
Utility knife

20mm open-end box wrench
17mm open-end box wrench
5/32" drill bit
25/32" drill bit

#2 Phillips screwdriver
Small flat blade screwdriver

5.1 PRIMARY MONITOR OPERATOR STATION

This operator station will include the wiring connections for the cable from the monitor and the incoming power. In many installations this operator station will also include the wiring connections for the wireless, joystick, or tether operator station. The enclosure is designed to be recess mounted in a panel.

5.1.1 MOUNTING

Select proper operator location. Panel space required will be 5-5/8" x 8" (142 x 200mm). A depth of 3-1/2" (89mm) will be required behind the panel. Additional space will be required where the cables exit the back of the enclosure. Refer to Figure 5.1.1 for cutout dimensions.

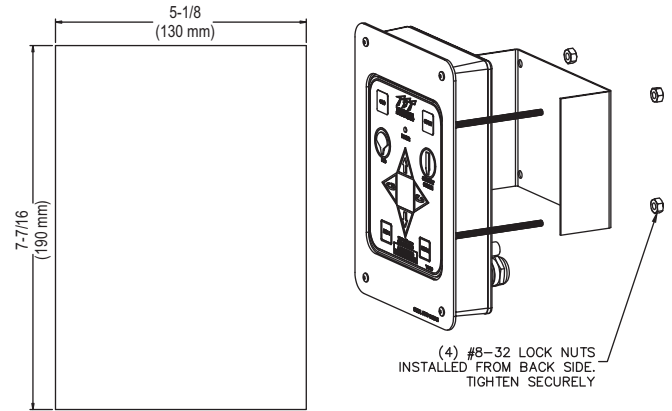

Fig 5.1.1
Primary & Optional Operator Stations Cutout Dimensions

5.1.2 ELECTRICAL WIRING

After selecting and mounting the desired operator stations, refer to Figures 5.1.2B-E for wiring connections. Refer to Figure 5.1.2A for typical cable preparation. Be sure to tighten all terminal block screws securely.

Receiver Cable Wire Color	Termination Point In Operator Station
RED	RED (+)
BLACK	BLACK (-)
GREEN/BLACK	UP
WHITE/BLACK	DOWN
WHITE	LEFT
ORANGE/BLACK	RIGHT
BLUE	FOG
ORANGE	STRAIGHT STREAM
GREEN	NOT USED (CUT)

Fig 5.1.2
Wireless Operator Station
Wiring Color Code

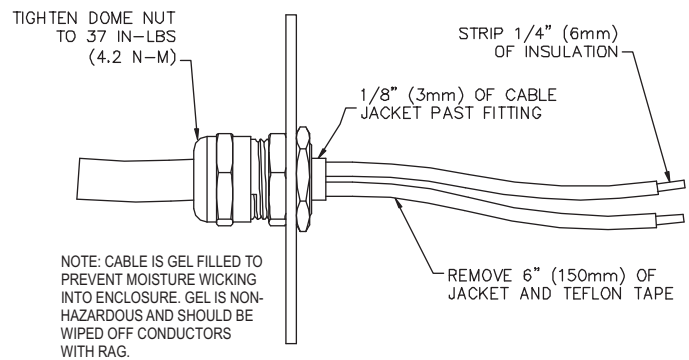

Fig 5.1.2A
Typical Cable Preparation

FROM/TO MONITOR OR OPERATOR STATION

Refer to Figure 5.1.2B for connections.

FROM/TO TETHER OR OPT. OPERATOR STATION

Remove rubber plug in hole labeled WIRELESS OPER. STATION and discard. Refer to Figure 5.1.2C for connections.

WIRELESS OPERATOR STATION

Plug end of cable with Deutsch connector into gray receptacle on receiver. Make sure connector snaps into place.

Remove rubber plug in hole labeled WIRELESS OPER. STATION and discard.

Refer to Figure 5.1.2D for connections. Refer to Figure 5.1.2 for wire color designations.

MAIN POWER CONNECTION TO TRUCK

Route cable and connect to a protected circuit from the truck's power distribution center. Connect the red wire to positive and the black wire to negative (ground). Refer to Figure 5.1.2E for connections.

IMPORTANT!!

When mechanical installation and electrical connections are complete, perform the following test to verify voltage supply is adequate and the current limiting feature is functioning.

- 1) Apply power to monitor control box.
- 2) Press LEFT or RIGHT button and hold until monitor reaches its stop position. Continue to hold button down.
- 3) Once movement is stopped, manually turn override knob in opposite direction while continuing to hold button down. If knob can be turned, then voltage supply is adequate. If knob cannot be turned and motor continues to operate, then the voltage supply or wiring is not adequate. Check connections and voltage connection point, rewire if necessary. **NOTE: Override knob will only turn in one direction.**

VERIFY RUBBER SEAL IS CLEAN AND UNDAMAGED.
VERIFY THAT NO WIRES ARE CAUGHT BETWEEN LID AND BOX.

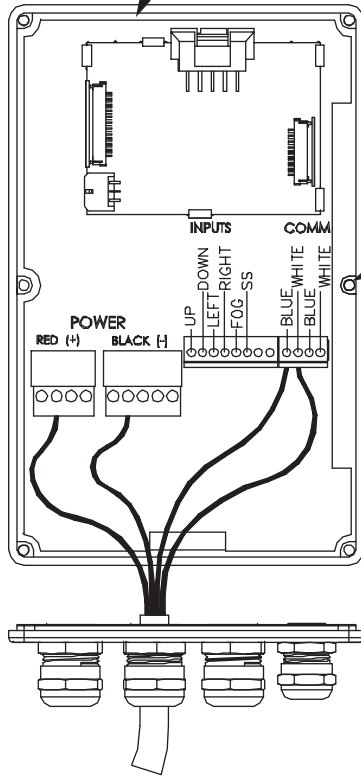

FIG 5.1.2B

From/To Monitor Or Operator Station Connections

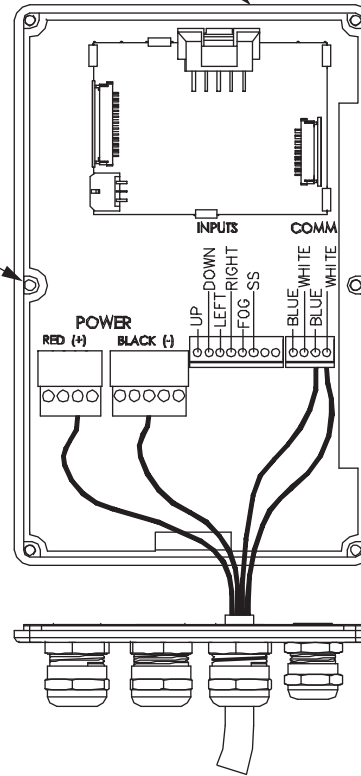
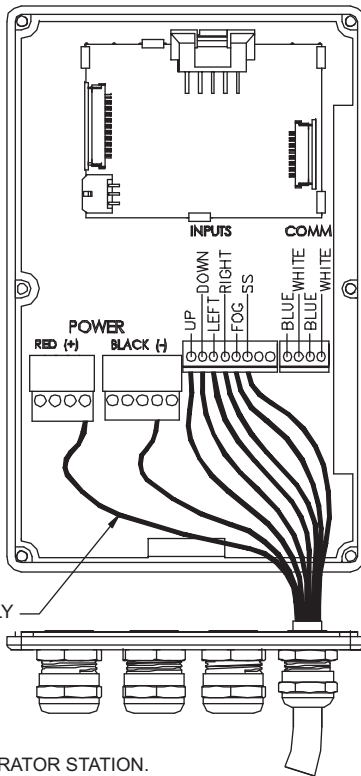

FIG 5.1.2C

From/To Tether, Optional Operator Station
Toggle Switch Operator Station,
or Communication Interface Box.

USE SUPPLIED FLAT HEAD
SCREWS WITH O-RING SEALS.
TIGHTEN SCREWS SECURELY.
(6) PLACES.



WIRELESS
STATION ONLY

WIRELESS OPERATOR STATION.
JOYSTICK OR INSTALLER SUPPLIED SWITCHES.
SEE SECTION 5.1.2 FOR TABLE DEPICTING
WIRELESS RECEIVER COLOR CODE.

FIG 5.1.2D

Wireless Operator Station Connections

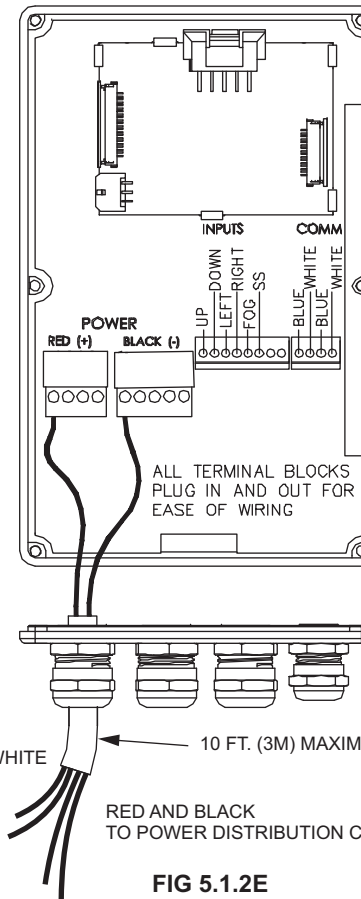

FIG 5.1.2E

Main Power Connections

5.2 OPTIONAL MONITOR OPERATOR STATIONS

The electronic package for the Hurricane RC is designed for multiple operator stations. The operator stations use an RS-485 communication design and the communication boards in each station are connected in series. This gives the flexibility to choose more than one location on a truck to operate the monitor. To install multiple operator stations, complete the following instructions in this section and repeat for each additional station. The enclosure is designed to be recess mounted in a panel.

5.2.1 MOUNTING

See section 5.1.1

5.2.2 ELECTRICAL WIRING

See section 5.1.2

5.3 TETHER MONITOR OPERATOR STATION

This operator station will have a factory installed 4-conductor cable, which will act as a tether, with a plug on the end. The installer will need to mount the holster and receptacle. Since the communication boards are connected in series, the receptacle for the tether operator station needs to be wired into the last primary or optional operator station (if multiple recessed operator stations are installed, refer to section 5.2).

The holster is supplied with (3) 1/4-20 stainless steel self-tapping screws. Make sure the material beneath the bracket is substantial and thick enough to hold self-tapping screws. Make sure the area on the back side of the mounting surface is clear of obstructions. We recommend a minimum thickness of 3/32" (.093" - 2.4 mm) in aluminum and 5/64 (.078"-2mm) in steel. See the chart in Figure 5.3.1 to determine the correct pilot hole size.

5.3.1 HOLSTER MOUNTING

Select proper location for mounting holster, preferably inside a storage compartment. Panel space required will be 6.5" x 8.0" (165 x 203mm). Refer to Figure 5.3.1 for hole dimensions. Holster can be used as template.

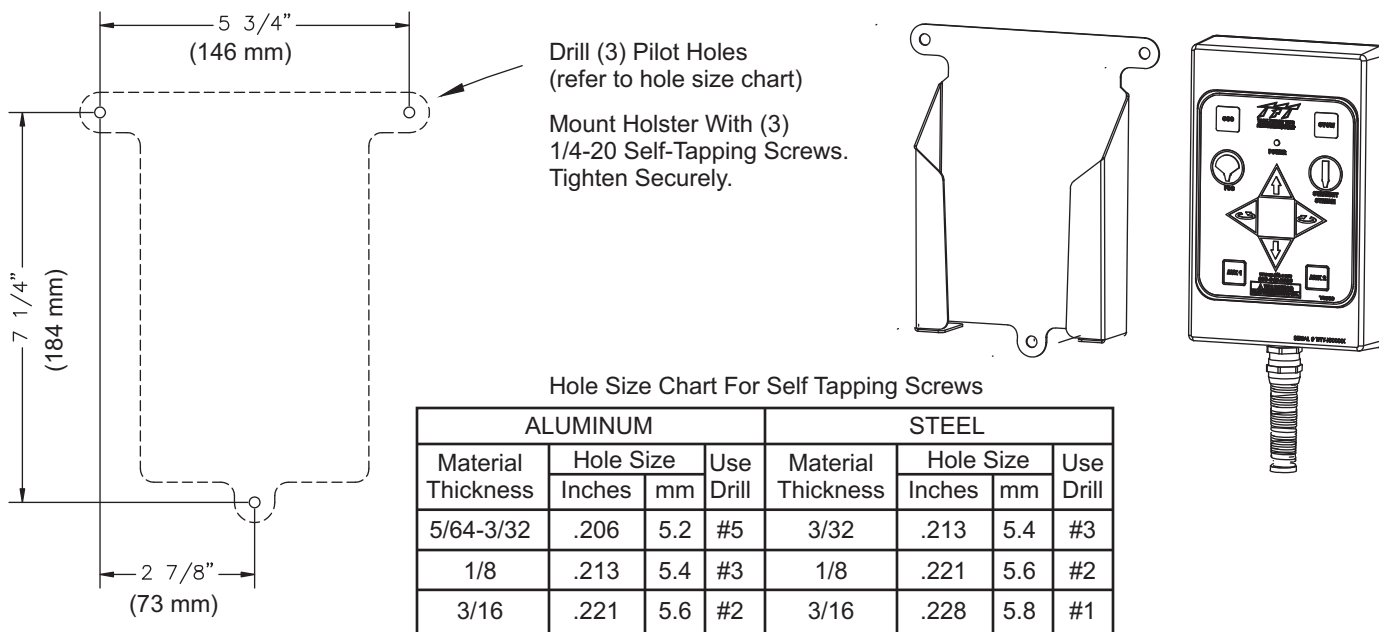

Fig 5.3.1 Tether Operator Station Holster Hole Dimensions

5.3.2 RECEPTACLE MOUNTING

Select proper location for mounting receptacle. Receptacle is 1-1/4" x 1-1/4" and 1/2" deep. (32 mm x 32 mm x 13 mm) Allow extra room behind receptacle for wires. Refer to Figure 5.3.2 for hole dimensions.

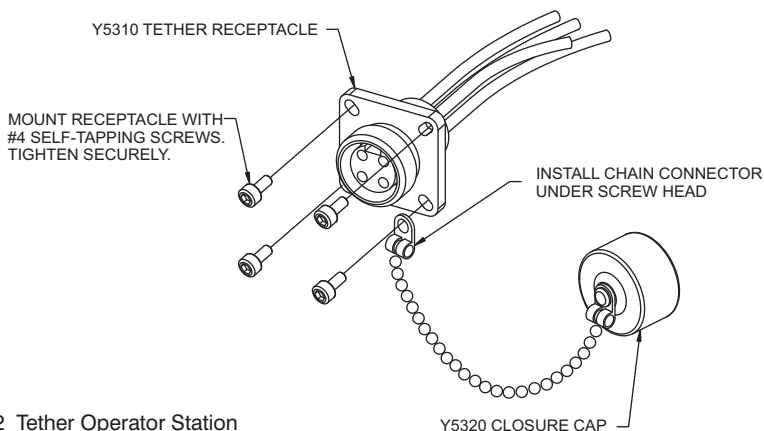
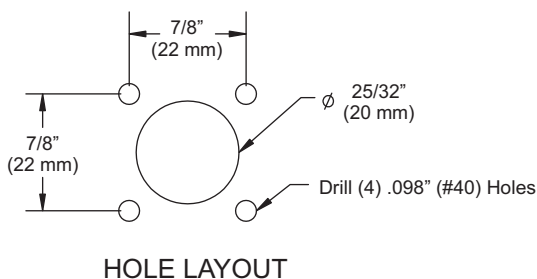

Fig 5.3.2 Tether Operator Station Receptacle Hole Dimensions

5.3.3 ELECTRICAL WIRING

See section 5.1.2

5.4 WIRELESS MONITOR OPERATOR STATION

This operator station consists of the wireless transmitter, receiver, receiver output cable, and charging cradle. The installer will need to mount the wireless receiver and wire it into the primary operator station. The charging cradle will need to be mounted in a weatherproof location and wired to a protected voltage supply.

The receiver is supplied with (2) 1/4-20 stainless steel self-tapping screws. Make sure the material beneath the receiver is substantial and thick enough to hold self-tapping screws. Make sure the area on the back side of the mounting surface is clear of obstructions. We recommend a minimum thickness of 3/32" (.093" - 2.4 mm) in aluminum and 5/64 (.078"-2mm) in steel. See the chart in Figure 5.4.1 to determine the correct pilot hole size.

5.4.1 MOUNTING - RECEIVER

Select proper location for mounting receiver. The receiver has a built-in antenna and needs to be in an open area so that it can receive the wireless signals. A location on the top of the truck is preferable. **The optimal operating range is 500' (150 m). Check the operating range after mounting receiver. If range is inadequate, the receiver may need to be remounted in a more exposed area.**

The receiver must be mounted so that the supplied 10' (3 m) output cable can be routed back to the primary operator station. Be sure to mount receiver so that the Deutsch connector is pointing down. Receiver size is 5.1" x 4.0" (130 x 102mm). Refer to Figure 5.4.1 for hole dimensions. Receiver can be used as template.

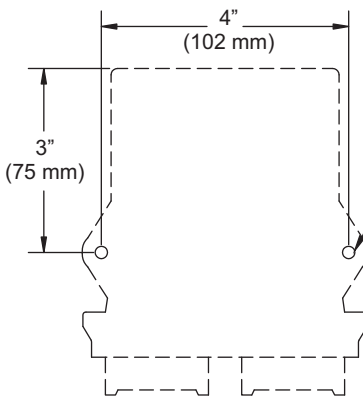

Fig 5.4.1

Wireless Receiver Hole Dimensions

DRILL (2) PILOT HOLES (refer to hole size chart).
MOUNT HOLSTER WITH (2) 1/4-20
SELF-TAPPING SCREWS. TIGHTEN SECURELY.

Hole Size Chart For Self Tapping Screws

ALUMINUM				STEEL			
Material Thickness	Hole Size		Use Drill	Material Thickness	Hole Size		Use Drill
	Inches	mm			Inches	mm	
5/64-3/32	.206	5.2	#5	3/32	.213	5.4	#3
1/8	.213	5.4	#3	1/8	.221	5.6	#2
3/16	.221	5.6	#2	3/16	.228	5.8	#1

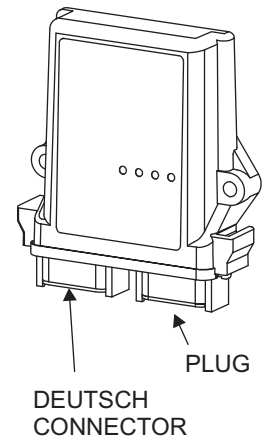

5.4.2 ELECTRICAL WIRING - RECEIVER TO THE PRIMARY OPERATOR STATION

See section 5.1.2

5.4.3 MOUNTING CHARGING CRADLE

Select proper location for mounting cradle. The cradle is not weatherproof and needs to be inside a protected location such as in the cab or a compartment. Cradle size is 4.2" x 4.5". Refer to Figure 5.4.3 for hole dimensions.

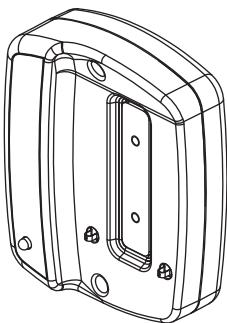

MOUNT CRADLE USING
CUSTOMER SUPPLIED HARDWARE.
TIGHTEN SECURELY.

Fig 5.4.3

Charging Cradle Hole Dimensions

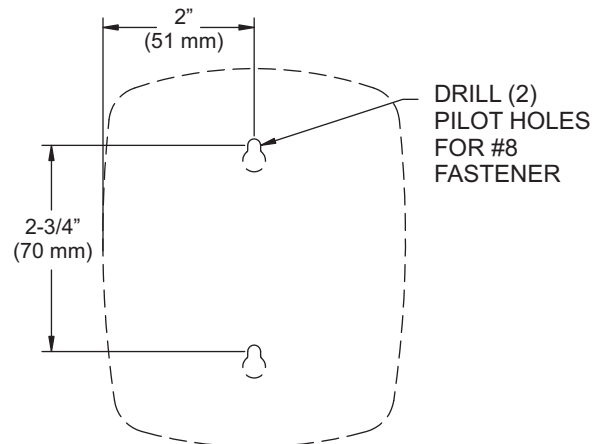

5.4.4 ELECTRICAL WIRING CHARGING CRADLE

Use two (2) 1/4" spade lugs to connect power to the cradle from a protected voltage supply from the truck's power distribution center. Connect the positive lead to the terminal marked CHARGE BATT and the negative (ground) lead to the terminal marked GROUND. Do not make connections to any other terminals. The circuit from the truck power distribution center should be energized continuously to keep the transmitter fully charged.

5.5 JOYSTICK MONITOR OPERATOR STATION

This operator station allows the monitor to be controlled by a joystick. The installer will need to mount the joystick and connect the cables to the communication interface box or to a primary operator station. The joystick needs to be mounted in a weatherproof location. Example: Inside the cab of the truck.

5.5.1 MOUNTING

Select proper weatherproof operating location. Joystick will require 4 1/2" x 4 1/2" (114 x 114mm) of panel space. A depth of 4" (100mm) will be required behind the panel. Refer to Figure 5.5.1.1 for hole dimensions.

After mounting, the installer may rotate the joystick up to 22 degrees in either direction. To rotate joystick, lift the rubber boot to expose adjustable clamp. Loosen the clamping screws, rotate the joystick to desired position, and tighten clamping screws.

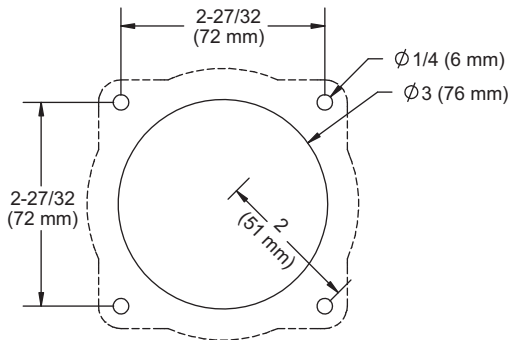

HOLE MOUNTING DETAIL

Fig 5.5.1.1
Joystick Operator Station
Hole Dimensions

Install joystick instruction label nearby for quick operation reference.

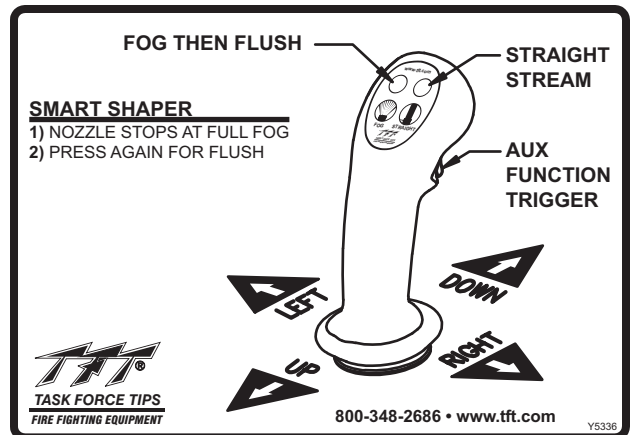

Fig 5.5.1.2
Joystick Instruction Label

5.5.2 ELECTRICAL WIRING

The joystick operator station must be connected to the included Y4E-COMM Communication Interface Box or a separately supplied Y4E-RP Primary Operator Station. By connecting the joystick to a communication interface box, a primary operator station is not required and the installer has the option to enable the joystick operator station with the master override feature (see Section 6.2.2). When a pump panel operator station is being installed, the installer can connect the joystick to the Primary Operator Station, which will eliminate the need to install the communication interface box.

5.5.2.1 WIRING TO A COMMUNICATION INTERFACE BOX

The joystick cables will be connected to the factory supplied 10' cable from the Communication Interface Box. See figure 5.5.2.1.

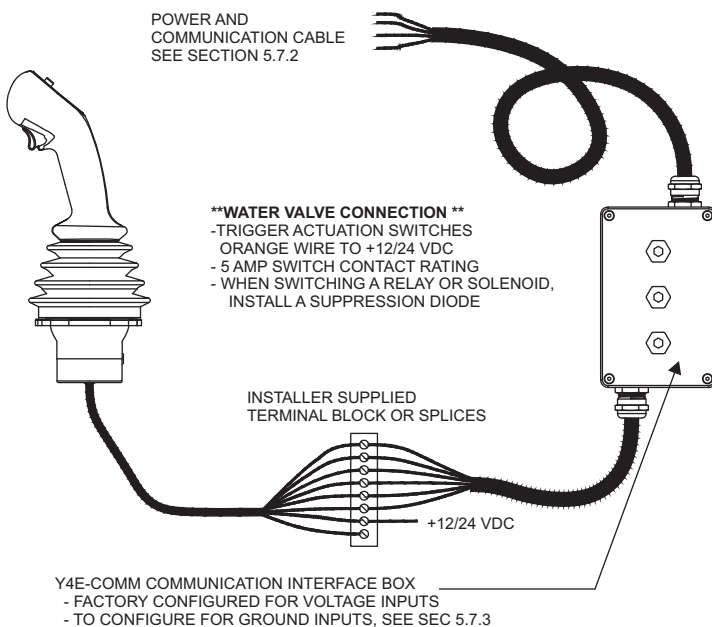

Fig 5.5.2.1
Joystick Operator Station Wiring
to Communication Interface Box

Function	Joystick Cable Color	Interface Box Cable Color
UP	Grey	WHITE
DOWN	Black/White	BLUE
LEFT	Tan	YELLOW
RIGHT	Pink	BROWN
COMMON	Red	N/A
STREAM	Blue	ORANGE
FOG	Green	GREEN
TRIGGER	Orange	Water Valve**
n/u	White	n/u
n/u	Brown	n/u
n/u	Black	n/u
n/u	Purple	n/u
n/u	Yellow	n/u

NOTE Do not connect 12VDC to Communication Interface Box wires if configured for GROUND inputs. This will result in damage to the communication board. See section 5.7.3.

5.5.2.2 WIRING TO A PRIMARY OPERATOR STATION

The joystick cable will enter the primary operator station through the connector labeled WIRELESS OPER. STATION. Refer to section 5.1.2D.

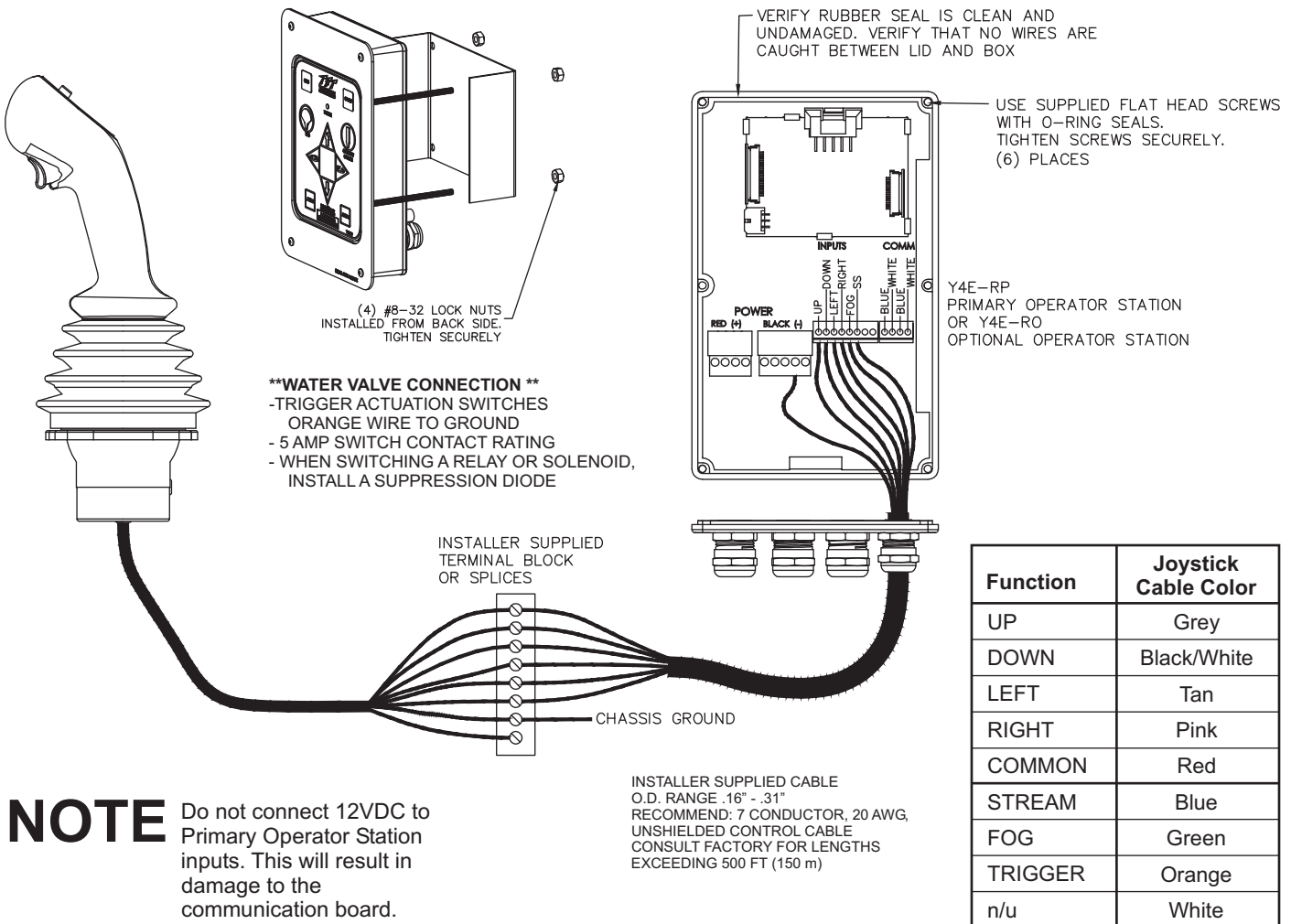

Fig 5.5.2.2
Joystick Operator Station Wiring to Primary Operator Station

5.6 TOGGLE SWITCH MONITOR OPERATOR STATION

This operator station allows the monitor to be controlled by three toggle switches. The installer will need to mount the operator station and connect the cable to a primary operator station or directly to the monitor.

5.6.1 ENCLOSURE MOUNTING

Select proper operator location. Enclosure is designed to be surface mounted and the size is 5" x 3 1/8" (127 x 80mm). Height to top of switches is 3 1/8" (80mm). Refer to Figure 5.6.1 for mounting hole dimensions.

5.6.2 ELECTRICAL WIRING

See section 5.1.2C if connecting to a Primary Operator Station. See section 5.10 if connecting directly to monitor.

MOUNT ENCLOSURE WITH (2) 1/4-20 FASTENERS. TIGHTEN SECURELY.

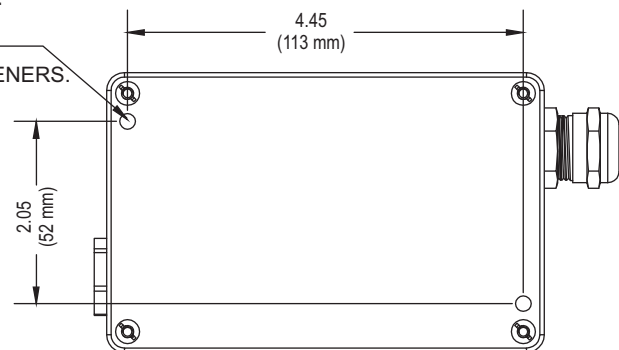

Figure 5.6.1
Toggle Switch Operator Station Hole Dimensions

5.7 COMMUNICATION INTERFACE BOX

This Communication Interface Box converts discrete input signals into serial communications for controlling the monitor. The discrete input signals can be from a joystick, toggle switches, relay contacts or Canbus output module. The interface box accepts +12/24 VDC signals, but can be field changed to accept ground signals. The installer will need to mount the interface box and connect the cable to a primary operator station or directly to the monitor.

5.7.1 ENCLOSURE MOUNTING

Select proper enclosure location. Enclosure is designed to be surface mounted and the size is 5" x 3 1/8" (127 x 80mm). Height of enclosure is 2 3/8" (60mm). Refer to Figure 5.6.1 for mounting hole dimensions.

5.7.2 ELECTRICAL WIRING

See section 5.1.2C for connecting power & communication cable. See section 5.10 if connecting directly to the monitor. See section 5.7.2 for connecting inputs cable.

5.7.3 INPUTS SIGNAL CONFIGURATION

The Communication Interface Box is shipped from the factory configured to accept +12/24 VDC input signals, but can be field changed to accept ground input signals.

To change the configuration:

1. Remove lid from enclosure.
2. Remove jumper to select GROUND inputs or install jumper to select VOLTAGE inputs.
3. Replace lid. Verify rubber seal is clean and undamaged. Verify that no wires are caught between lid and box.

Function	Interface Box Cable Color
UP	WHITE
DOWN	BLUE
LEFT	YELLOW
RIGHT	BROWN
FOG	GREEN
STREAM	ORANGE
SPEED	BLACK
STOW	RED

Figure 5.7.2
Communication Interface
Wire Color/Function

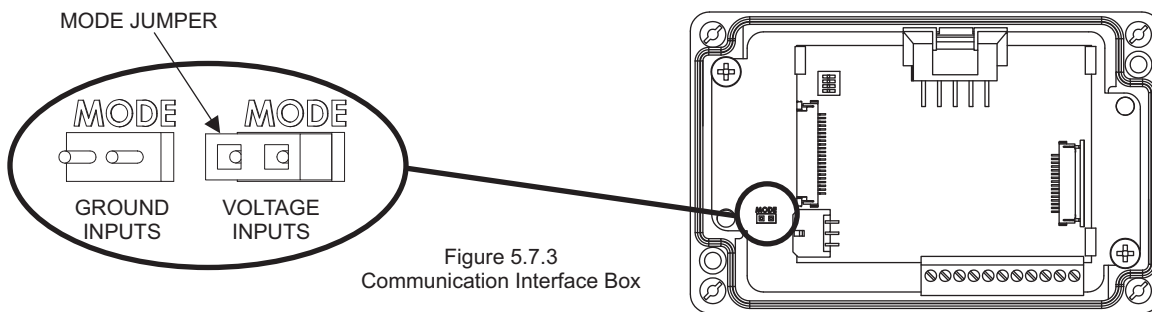

Figure 5.7.3
Communication Interface Box

5.8 MONITOR POSITION DISPLAY

The monitor position display is supplied with a 10' (3 m) long 4-conductor cable. The installer will need to surface mount the enclosure in a dry area and connect the cable to power and the communication link of the monitor. Display is designed for use with 180° total horizontal axis travel.

5.8.1 ENCLOSURE MOUNTING

Select proper location for display. The display is not weatherproof and needs to be inside a protected area such as in the cab.

MOUNT ENCLOSURE WITH
(2) #10 FASTENERS.
TIGHTEN SECURELY.

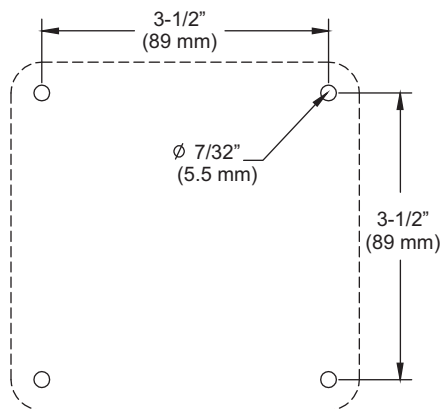
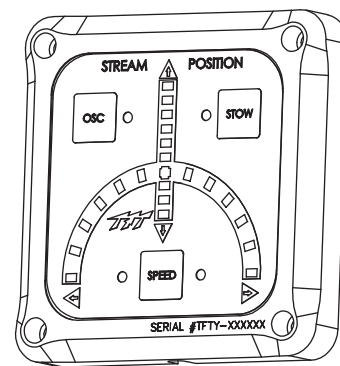

Fig 5.8.1 - Monitor Position Display Hole Dimensions



5.8.2 ELECTRICAL WIRING

The monitor position display needs to be connected to +12/24VDC (red) and ground (black). The blue & white wires from the position display cable need to be connected to the blue & white wires from the monitor. A terminal box or a high quality, protected splice can be used to make these connections. See section 5.10 for connecting power and communication cable.

5.9 CONNECTING MONITOR CABLE DIRECTLY TO PROTECTED POWER SUPPLY

The electric RC monitor has an operator station, which is fully functional, mounted on the monitor. If no other operator stations are selected, the installer will only need to connect power to complete the installation.

5.9.1 ELECTRICAL WIRING

Route cable from monitor and connect to a protected circuit from the truck's power distribution center. Connect the red wire to positive and the black wire to negative (ground). Cut and discard blue and white wires.

5.10 OPERATOR STATION INSTALLED DIRECTLY ON MONITOR

The electric RC monitor can be directly connected to a protected power supply, see section 5.9, and then be controlled by one of the following without the use of a Y4E-RP, primary operating station.

- Tether Operator Station, see section 5.3 for holster and receptacle mounting.
- Toggle Switch Operator Station, see section 5.6 for mounting.
- Communication Interface Box, see section 5.7 for mounting.

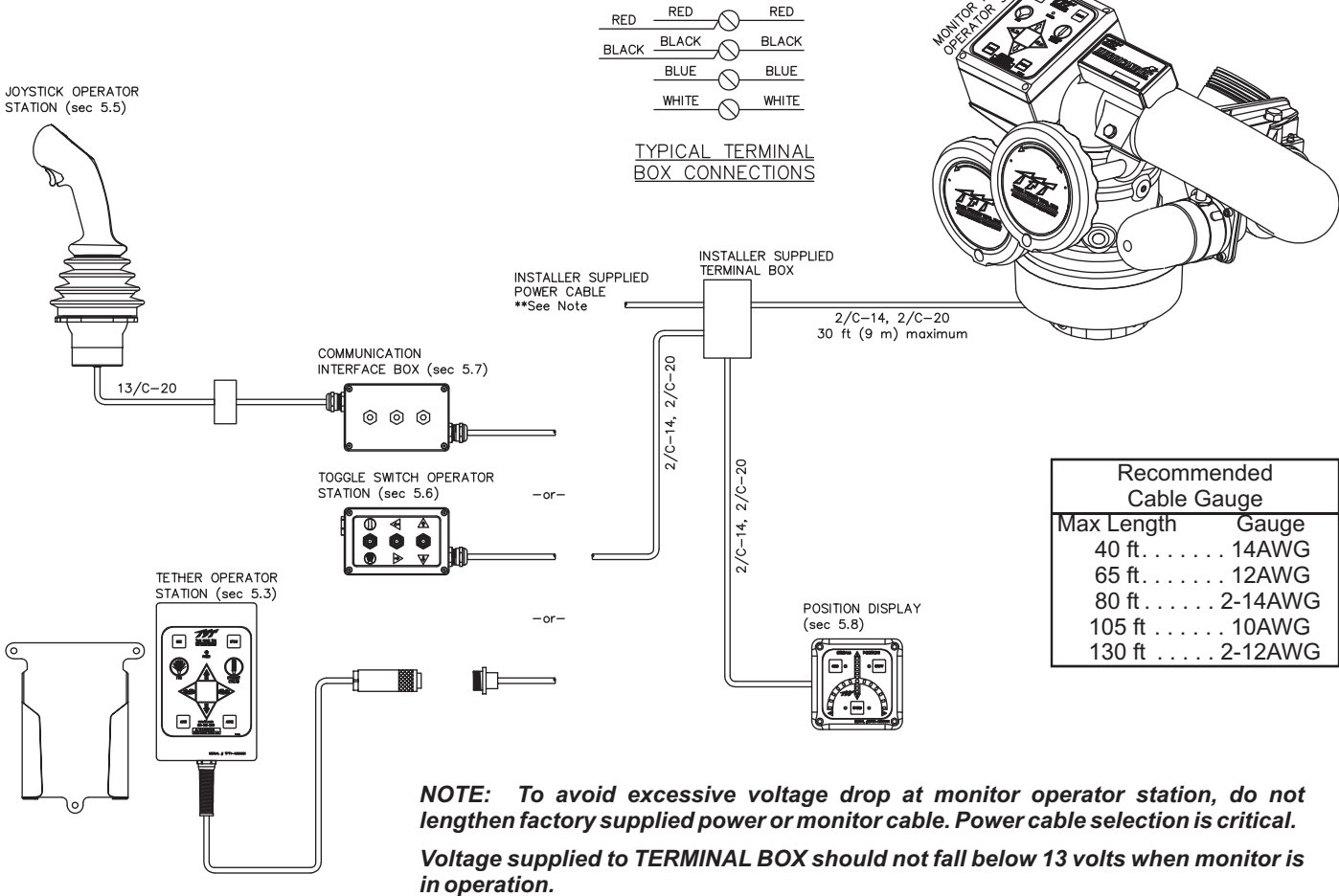

Figure 5.10
Electrical Components
(operator station directly to monitor installations)

5.11 ELECTRICAL RC MONITOR AERIAL TRUCK INSTALLATION

When installing the electric RC monitor on an aerial device truck, refer to section 5.11.2.1 or 5.11.2.2.

5.11.1 ELECTRONICS ENCLOSURE MOUNTING

Select proper enclosure location. Enclosure is designed to be surface mounted and the size is 5 3/4" x 8 3/4" (146 x 222mm). Height of enclosure is 2 1/4" (57mm). Refer to Figure 5.11.1 for mounting hole dimensions.

5.11.2 ELECTRICAL WIRING

On aerial devices, the installer will supply the required cables that run up the ladder or boom. Be sure to perform voltage drop calculations to verify that the supply voltage will remain at an acceptable level during monitor operation.

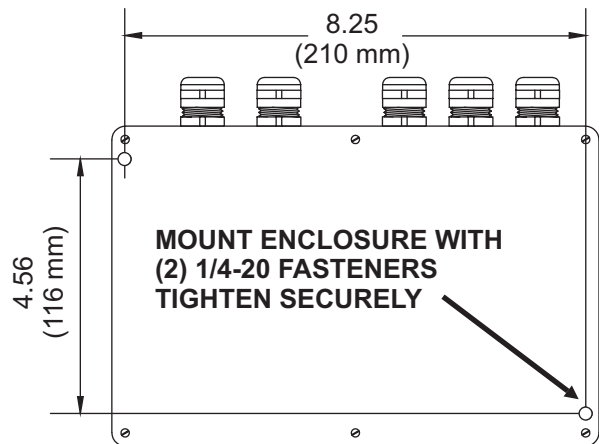

Fig 5.11.1
Electrical Enclosure
Mounting Hole Dimensions

5.11.2.1 LADDER INSTALLATION ELECTRICAL WIRING (-L MODELS)

The electronics enclosure converts discrete input signals into serial communications for controlling the monitor. The discrete input signals can be from a joystick, toggle switches, relay contacts or Canbus output module. The electronic interface accepts +12/24 VDC signals, but can be field changed to accept ground signals.

The electronics enclosure is configured so that signals connected to the PRIMARY CONTROL cable will override any other operator stations (see section 6.2.1).

See Figure 5.11.2.1 for wiring connections.

Recommended Cable Gauge	
Max Length	Gauge
40 ft.	14AWG
65 ft.	12AWG
80 ft.	2-14AWG
105 ft.	10AWG
130 ft.	2-12AWG

MONITOR CABLE COLOR	TERM. BLOCK CONNECTION
RED	RED (+)
BLACK	BLACK (-)
BLUE	BLUE
WHITE	WHITE

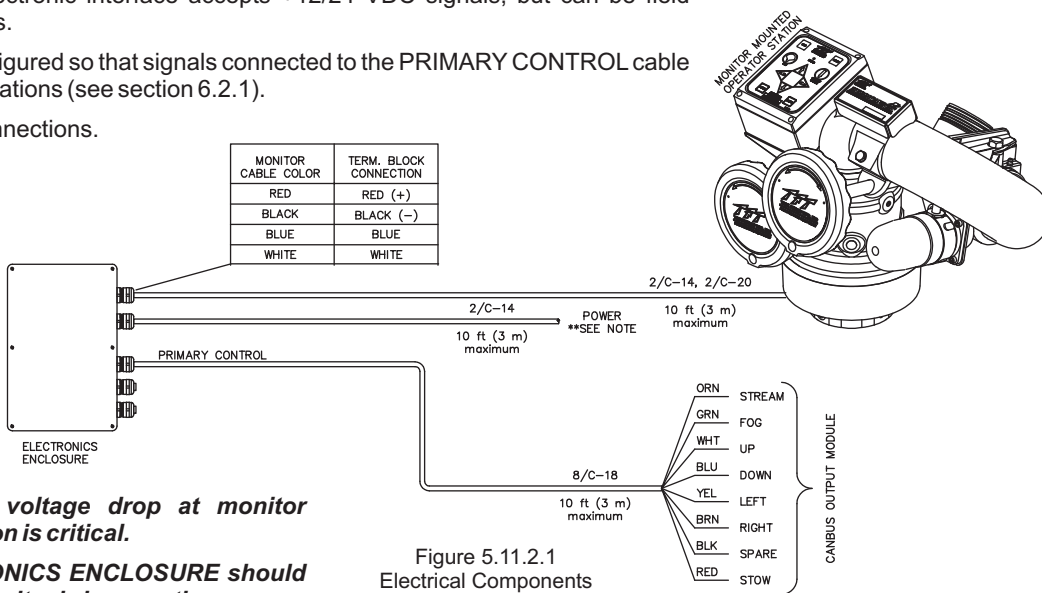

NOTE: To avoid excessive voltage drop at monitor operator station, cable selection is critical.

Voltage supplied to ELECTRONICS ENCLOSURE should not fall below 11 volts when monitor is in operation.

Figure 5.11.2.1
Electrical Components
(ladder installations)

5.11.2.2 PLATFORM INSTALLATION ELECTRICAL WIRING

The electronics enclosure converts discrete input signals into serial communications for controlling the monitor. The discrete input signals can be from a joystick, toggle switches, relay contacts or Canbus output module. The electronic interface accepts +12/24 VDC signals, but can be field changed to accept ground signals.

The electronics enclosure is configured so that signals connected to the PRIMARY CONTROL cable will override any other operator stations (see section 6.2.1).

See Figure 5.11.2.2 for wiring connections.

Recommended Cable Gauge	
Max Length	Gauge
40 ft.	14AWG
65 ft.	12AWG
80 ft.	2-14AWG
105 ft.	10AWG
130 ft.	2-12AWG

MONITOR CABLE COLOR	TERM. BLOCK CONNECTION
RED	RED (+)
BLACK	BLACK (-)
BLUE	BLUE
WHITE	WHITE

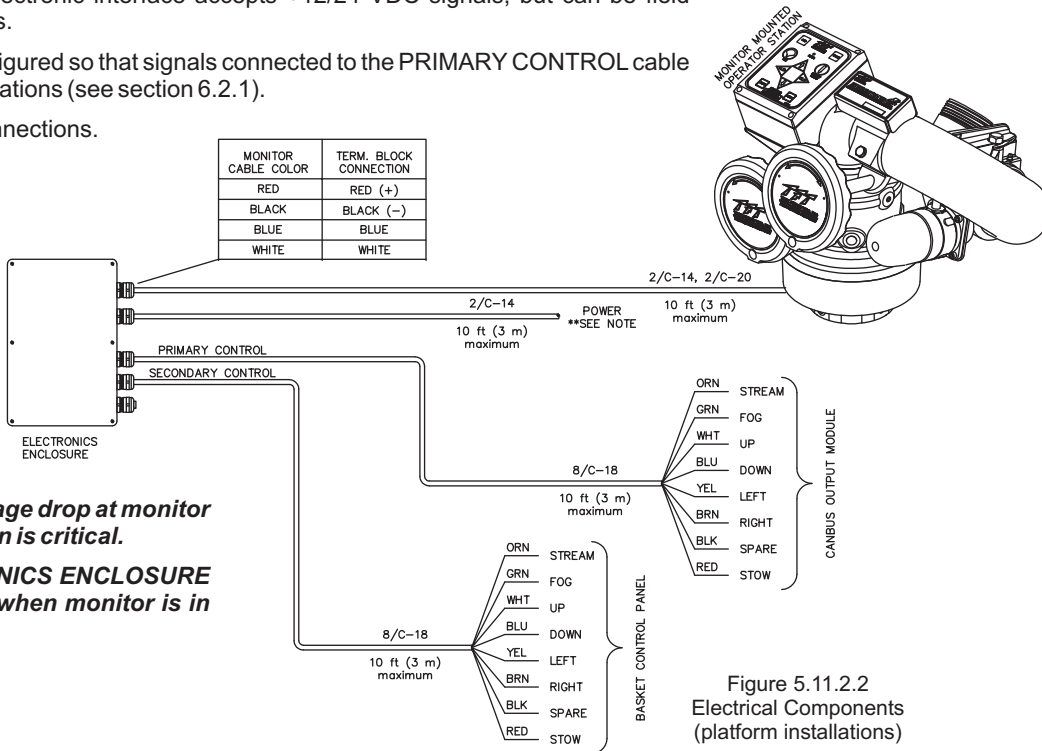

NOTE: To avoid excessive voltage drop at monitor operator station, cable selection is critical.

Voltage supplied to ELECTRONICS ENCLOSURE should not fall below 11 volts when monitor is in operation.

Figure 5.11.2.2
Electrical Components
(platform installations)

5.12 ELECTRIC NOZZLE ACTUATOR WIRING

The electric RC monitor is designed to control and is factory wired for a TFT electric actuated nozzle. Task Force Tips nozzles are available with a male cord plug. After mounting the appropriate nozzle onto the monitor, plug the male cord from the nozzle into the female cord located on the outlet of the monitor. Make sure the two coupling nuts are tightened securely to ensure a proper watertight seal.

If retrofitting an existing TFT nozzle, a male cord plug (TFT #Y5285) can be purchased and installed in place of the existing actuator cord. Please consult factory for installation.

6.0 OPERATION

6.1 OVERRIDE HANDWHEELS

In the event of electrical system failure of the monitor or fire truck, Hurricane RC is factory supplied with handwheels so the monitor may be manually operated. The factory-supplied handwheels are 6 inches in diameter. To make the Hurricane RC more compact, the handwheels may be removed.

6.2.1 OPERATOR STATIONS

The electric Hurricane RC monitor has seven different styles of operator stations for use in various locations on the fire truck or fire ground.

The design of the operator station communications allows users to override commands on other stations. The "last" button pressed has control. The overridden user can regain control by releasing his/her button and pressing again. The wireless and joystick operator stations cannot override commands from the primary operator station they are wired into, but can override other stations.

Platform and ladder electronics enclosures are pre-configured for one set of inputs to have a master override feature. The operator station connected to these inputs, typically at the base of the ladder, will override any other operator station.

Any operator station with a communication board or connected to a communication board can be field configured with the master override feature. This allows the user to setup an operator station on the fire truck or fire ground as the master override station. See Section 6.2.2 for details.

6.2.1.1 MONITOR MOUNTED OPERATOR STATION

This operator station is factory installed on the monitor and is used by personnel right at the monitor.

6.2.1.2 PRIMARY OPERATOR STATION

This operator station is installed on the truck, for example the pump operator's panel. It is used to operate the monitor from a location on the truck.

6.2.1.3 OPTIONAL OPERATOR STATION

This operator station allows the monitor to be operated from an additional location on the truck.

6.2.1.4 TETHER OPERATOR STATION

This operator station is tethered to the truck with either a 30 foot (9 meter) cable or a 100 foot (30.5 meter) cable. It is used to move slightly away from the truck to get a better view for redirecting the monitor.

6.2.1.5 WIRELESS OPERATOR STATION

This operator station uses RF signals to control the monitor. It is used to move far away from the truck to get a better view for redirecting the monitor. Maximum range is 500 ft (152 meters). The wireless transmitter is coded to a particular monitor so several wireless monitors may be in use at the same location without interference. It uses rechargeable batteries that will give 160 hours of continuous operation when fully charged. When not in use the wireless transmitter should be kept in its charging base. The transmitter will turn on a red LED to warn the operator when the battery charge is low. After this point there are less than 8 hours of continuous use available.

To activate the transmitter, press the green button at the top. While the transmitter is active, the yellow LED will blink continuously.

Pressing the red button at the bottom will deactivate the transmitter. The transmitter will automatically deactivate after 10 minutes if no buttons are pressed.

6.2.1.6 JOYSTICK OPERATOR STATION

This operator station is installed in a protected location and allows the monitor to be controlled by a joystick.

6.2.1.7 TOGGLE SWITCH OPERATOR STATION

This operator station allows the monitor to be operated by three toggle switches.

6.2.2 MASTER OVERRIDE FEATURE (DIP #1)

Any operator station with a communication board can be reconfigured with the master override feature. These stations include the Y4E-RP, Y4E-RO, Y4E-CT-30, Y4E-CT-100, Y4E-TS, or any inputs connected to an Y4E-COMM. To enable the master override feature on an operator station, follow these steps:

1. Remove lid from enclosure.
2. Locate DIP switches on communication board.
3. Slide DIP switch #1 to the ON position.
4. Replace lid. Verify rubber seal is clean and undamaged. Verify that no wires are caught between lid and box.

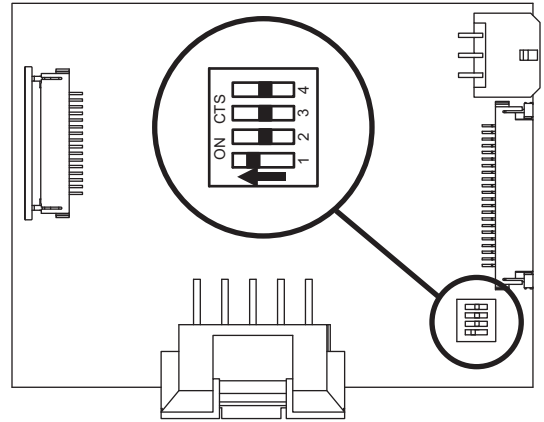

Figure 6.2.2
Master Override Setup

6.2.3 STOW FEATURE

The STOW position needs to be programmed during installation. The monitor needs to “find” two (2) hard stops, one for each axis, before the monitor can move to the STOW position. When programming, the first two commands teach the monitor where to find the hard stops. This guarantees that the position is accurate. From that point, the programmer can program the move to the final STOW position.

During normal operation, each time the STOW button is pressed, the monitor moves the nozzle to the full straight stream position, moves to each programmed hard stop, and then moves to the STOW position. While the monitor is performing the STOW feature, pressing any button will stop the monitor.

6.2.3.1 PROGRAMMING

STOW programming must be initiated within 1 minute of applying power to monitor. After 1 minute, programming access is blocked. Power must then be cycled to reset 1 minute timer.

Press and hold STOW button (~10 seconds) until LED blinks. Release button. LED will continue to blink while in program mode.

FIRST AXIS TO MOVE:

Press and release LEFT/RIGHT or UP/DOWN button of axis that will move to first hard stop. LED will blink rapidly when hard stop is reached.

SECOND AXIS TO MOVE:

Press and release LEFT/RIGHT or UP/DOWN button of axis that will move to second hard stop. LED will blink rapidly when hard stop is reached.

MOVE TO STOW POSITION:

Use LEFT/RIGHT or UP/DOWN buttons to move monitor to first point of stow routine, press and release STOW button. LED will blink rapidly to acknowledge position.

Repeat until pattern is complete (up to 10 points).

Press and hold STOW button until LED turns off. Release button.

6.2.3.2 STOW PROGRAMMING EXAMPLE

- Press and hold STOW button until LED blinks.
- Press and release UP button, monitor will move until hard stop reached. LED blinks rapidly.
- Press and release RIGHT button, monitor will move until hard stop reached. LED blinks rapidly.
- Press LEFT button to move 45 degrees, Press and release STOW button. LED blinks rapidly.
- Press DOWN button to move 90 degrees, Press & release STOW button. LED blinks rapidly.
- Press and hold STOW button until LED turns off.

6.2.4 OSCILLATE FEATURE

The OSCILLATE feature allows the user to program a repeating pattern to control the horizontal and vertical axes of the monitor. While in the OSCILLATE pattern, the monitor will pause while the user changes the stream pattern. Pressing any other button will stop the OSCILLATE pattern.

A label is supplied with each operator station that can be mounted on or near the station as a reminder of how to program the OSCILLATE pattern. The OSCILLATE pattern needs to be programmed before use. The pattern will be cleared each time power is cycled to the monitor. For fixed monitors, the monitor may be configured to store the program permanently. See Section 6.2.4.2.

6.2.4.1 PROGRAMMING

- Move monitor to starting point of pattern.
- Press and hold OSC button (~5 seconds) until LED blinks. Release button. LED will continue to blink while in program mode.
- Move monitor to second point, press OSC button. LED will blink rapidly to acknowledge position.
- Repeat until pattern is complete (up to 65 points).
- Press and hold OSC button until LED turns off. Release button.

<p>TO OSCILLATE: Press & release OSC button. (Pattern must be programmed first.)</p>	<p>TO STOW: Press & release STOW button. (Programmable, refer to manual.)</p>	
<p>OSCILLATE PATTERN PROGRAMMING:</p> <ol style="list-style-type: none"> 1) Move monitor to starting point of pattern. 2) Press & hold OSC button until LED blinks. LED will continue to blink in program mode. 3) Move monitor to 2nd point, press OSC button. LED will blink rapidly to acknowledge position. 4) Repeat until pattern is complete. 5) Press & hold OSC button until LED turns off. <p>NOTE: PATTERN WILL BE CLEARED UPON POWER LOSS.</p>		
		<p>800-348-2686 www.tft.com/tornado</p> <p style="text-align: right;">Y5705</p>

Figure 6.2.4.1
Operator Station Label

6.2.4.2 OSCILLATE PATTERN RETAIN FEATURE (DIP #4)

The monitor can be configured so that upon power up, the OSCILLATE pattern is retained. The OSCILLATE pattern will need be programmed at least one time (see section 6.2.4.1). To enable the OSCILLATE pattern retain feature on a monitor follow these steps:

1. Remove lid from monitor operator station.
2. Locate DIP switches on communication board.
3. Slide DIP switch #4 to the ON position.
4. Replace lid. Verify rubber seal is clean and undamaged. Verify that no wires are caught between lid and box.
5. Program OSCILLATE pattern.

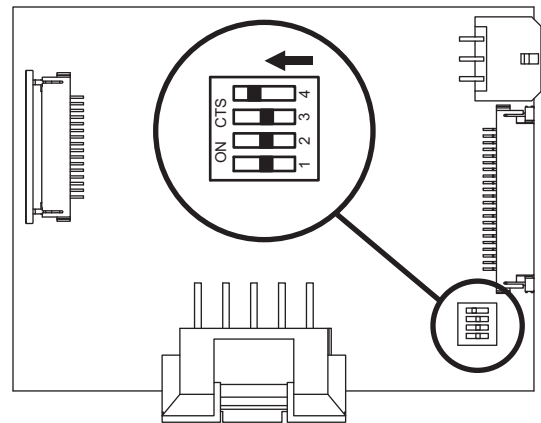

Figure 6.2.4.2
Oscillate Pattern Retain Setup

6.2.5 OPERATOR STATION PANELS

The operator stations are all equipped with the same monitor movement functions. From the operator stations, the operator can command the monitor up, down, left, right and command the nozzle pattern shaper from fog to straight stream. Operator stations supplied with the membrane switch, shown on the left below, allow the operator to program and perform the oscillate and stow features.



Fig 6.2.5
Operator Station Button Layouts

6.3 RECOMMENDED MONITOR STOWING POSITION

For truck mounted applications, it is recommended that the monitor be stowed in a position such that the monitor's nozzle rests against a bracket or support surface. This will minimize bouncing of the nozzle when the apparatus is traveling. **Always be sure the monitor is properly stowed before moving the truck and know the overall height to avoid damage from overhead obstructions such as doors or bridges.**

On many vehicle installations, the monitor is the highest point on the apparatus. Often it is critical that the monitor be properly stowed before driving to avoid damage to overhead obstructions, such as door openings. In these cases, the use of a switch wired into the apparatus's "door open" circuit is highly recommended. The switch would be wired to give a "door open" signal if the monitor is not in the stowed position. Due to the variety of possible mountings and nozzles, it is the installer's responsibility to supply the appropriate switch with mounting and wire it into their system. Always check stowed position of monitor before moving apparatus.

6.4 AUTOMATIC DRAIN

Doing the following may disable the automatic drain:

Refer to the exploded view in Section 9.0.

- 1) Unscrew the drain assembly from the monitor and remove the screw (#33) and washer (#28).
- 2) Turn over the rubber drain valve (#32) so that the raised edge is facing down, against the face of the housing (#31).
- 3) Reinstall the washer and screw. Reinstall the drain assembly.

6.5 FLOWS AND PRESSURES

The Hurricane RC is designed for a maximum pressure of 200 psi (14 bar). Do not exceed these limits.



The stream exiting a monitor is very powerful and capable of causing injury and property damage. Make sure the monitor is securely attached to the base and pointing in a safe direction before water to the monitor is turned on. Use care in directing the stream.

Because the stream trajectory can obscure the view of the operator, it is recommended that a spotter be used to accurately direct the stream.

6.5.1 STACKED TIPS FLOW AND REACH

English Units

Nozzle Diameter (inches)	Nozzle Pressure (PSI)							
	40		60		80		100	
	Flow GPM	Reaction lbf	Flow GPM	Reaction lbf	Flow GPM	Reaction lbf	Flow GPM	Reaction lbf
1.375	360	120	440	180	500	240	560	300
1.50	420	140	520	210	600	280	670	350
1.75	580	190	700	290	810	380	910	480
2.00	750	250	920	380	1060	500	1190	630

1 bar = 14.5 psi
1 gal = 3.785 l/min

Metric Units

Nozzle Diameter (MM)	Nozzle Pressure (BAR)							
	2.8		4.1		5.5		7	
	Flow l/min	Reaction kg	Flow l/min	Reaction kg	Flow l/min	Reaction kg	Flow l/min	Reaction kg
35	1360	50	1670	80	1890	110	2120	140
38	1590	60	1970	100	2270	130	2540	160
45	2200	90	2650	130	3070	170	3440	220
50	2840	110	3480	170	4010	230	4500	290

1 bar = 14.5 psi
1 gal = 3.785 l/min

FIG 6.5.1A
Stacked Tip Flow Table

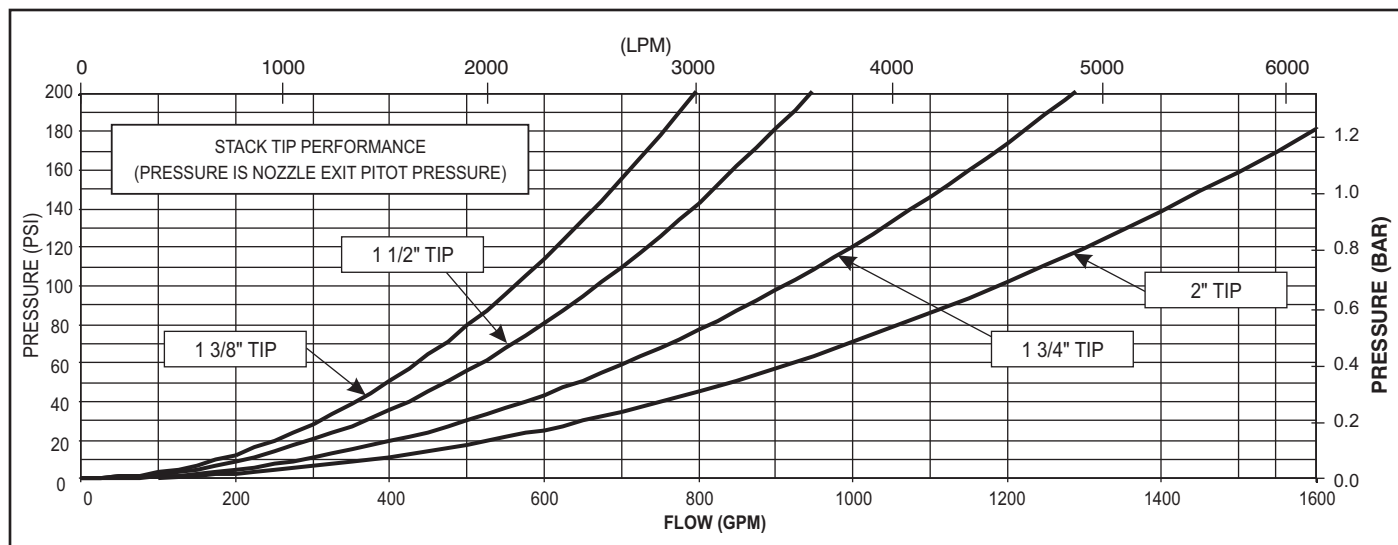

FIG 6.5.1B
Stacked Tip Flow Graph

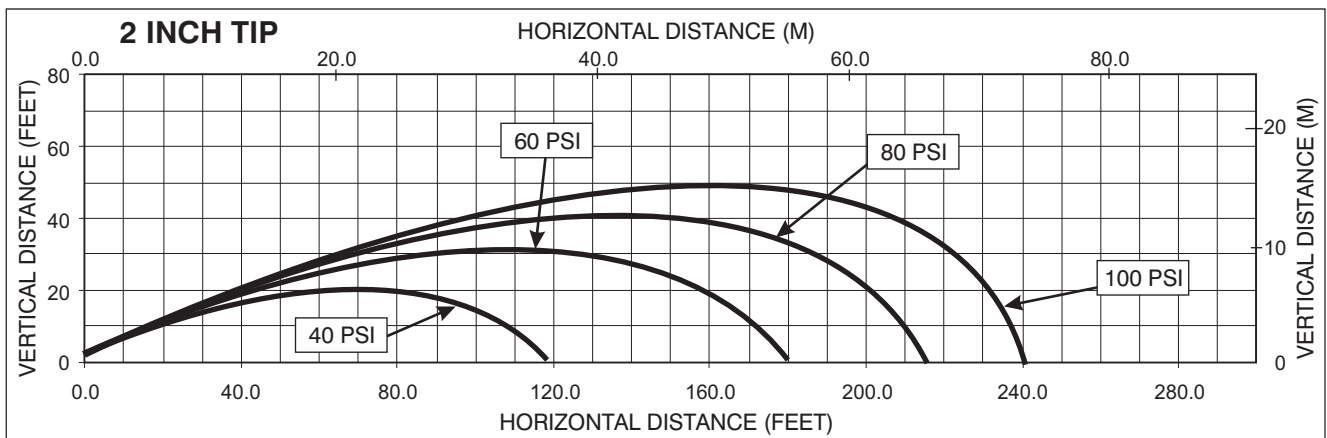
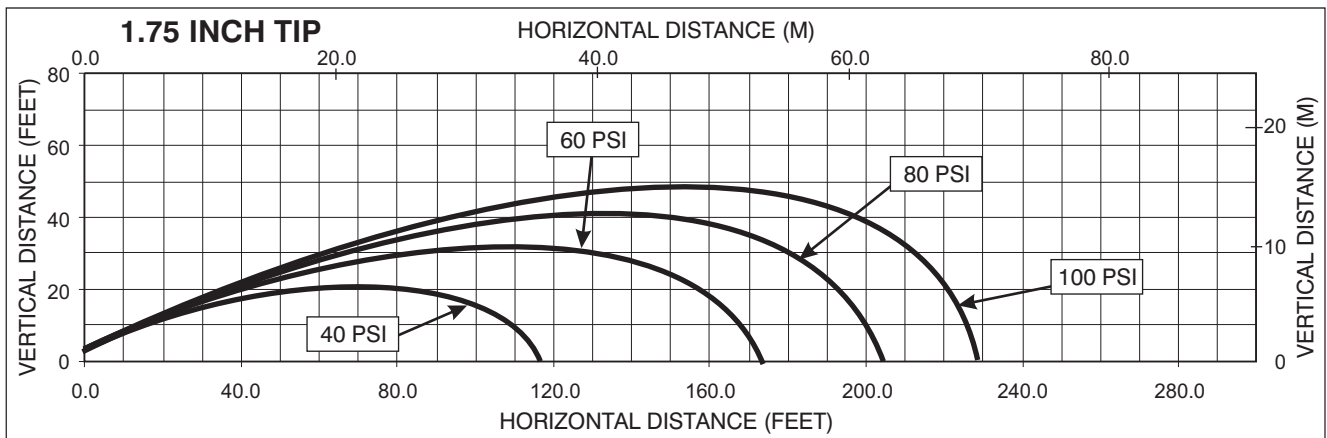
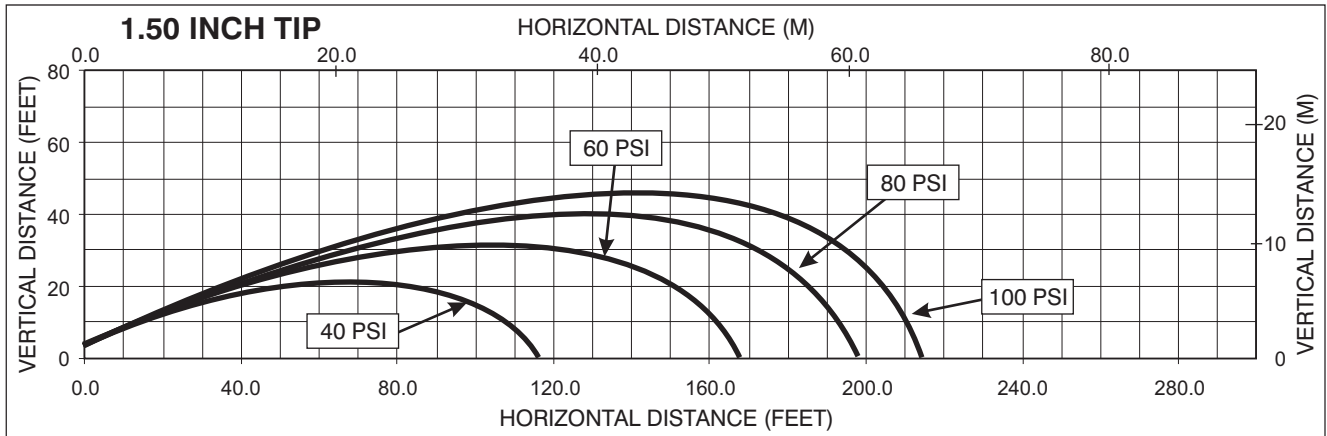
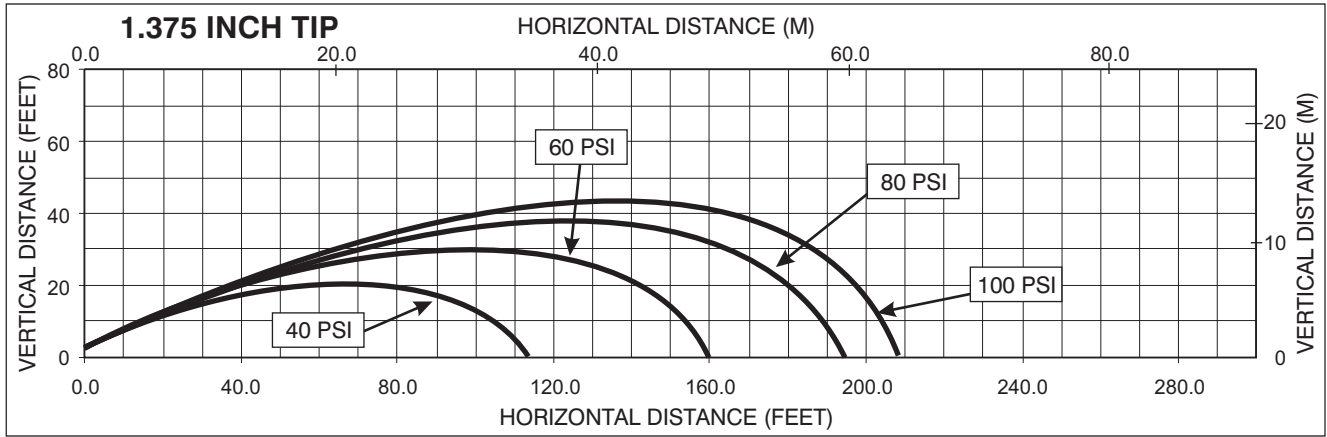
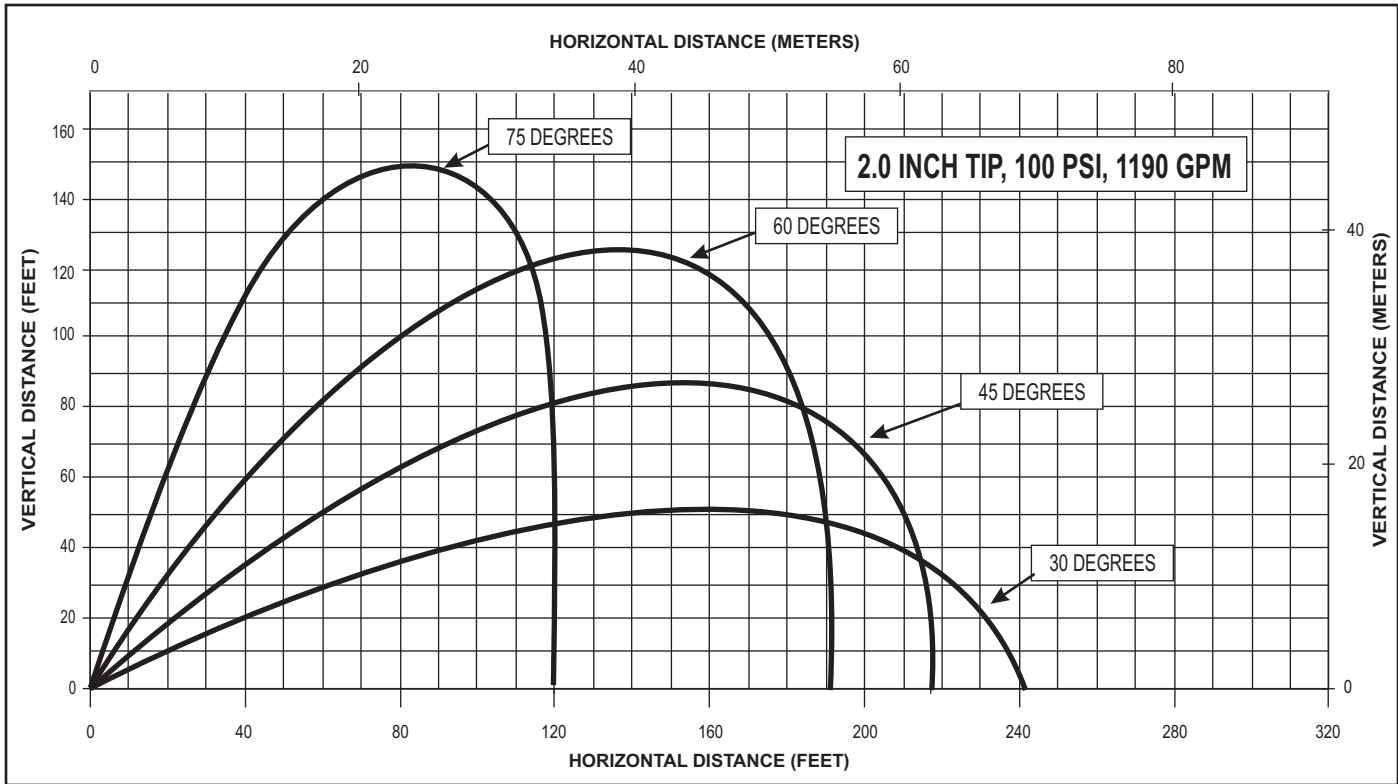

FIG 6.5.1C
Stacked Tips Stream Trajectory Graphs



This graph is approximate only.
 Critical applications should be tested in actual conditions to verify adequate reach.

FIG 6.5.1D
 Effects Of Elevation Of Trajectory

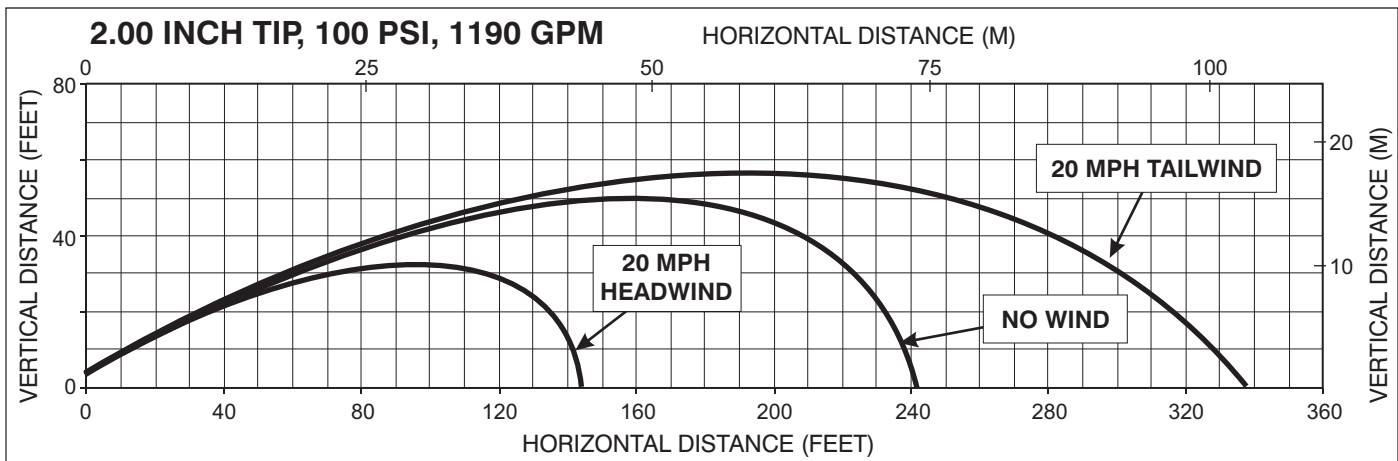

FIG 6.5.1E
 Effects of wind on reach

This graph shows approximately how a moderate wind can affect stream reach. **1 ft = 0.3048 m**

6.5.2 AUTOMATIC NOZZLES

Automatic nozzles maintain a constant pressure by adjusting their orifice to match the available flow. Consult the nozzle's manufacturer for maximum flow and pressure ratings. In all cases, do not exceed 1250 gpm (4500 l/min). TFT's Masterstream 1250 Nozzle has a 150-1250 gpm (600 - 4500 l/min) flow range. Masterstream 1250 Nozzle operating instructions (Item Number LIM-030) are available on TFT's website: www.tft.com

6.5.3 HURRICANE RC MONITOR FRICTION LOSS

The friction loss of the Hurricane RC Monitor is shown below in Fig.6.5.3.

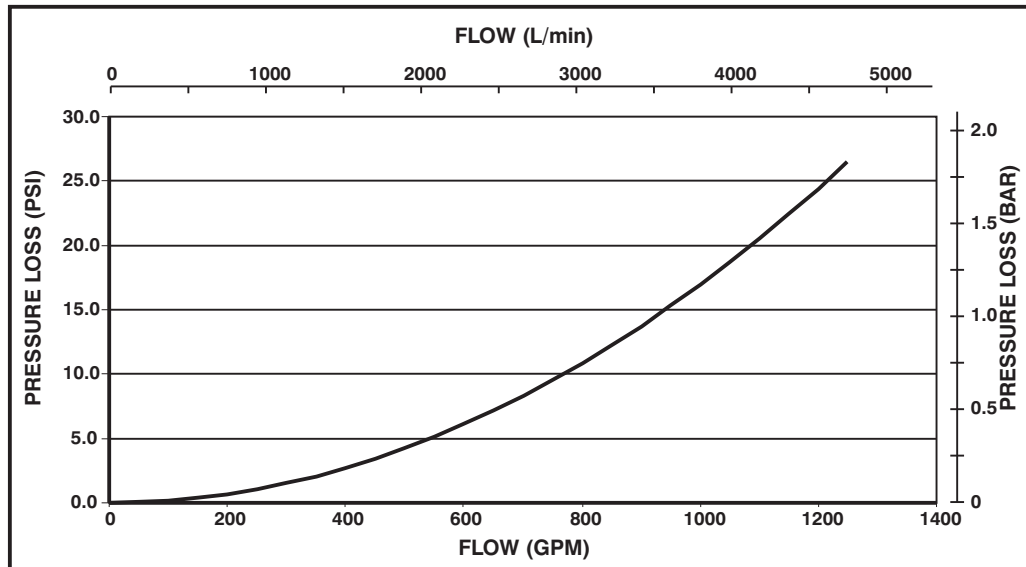
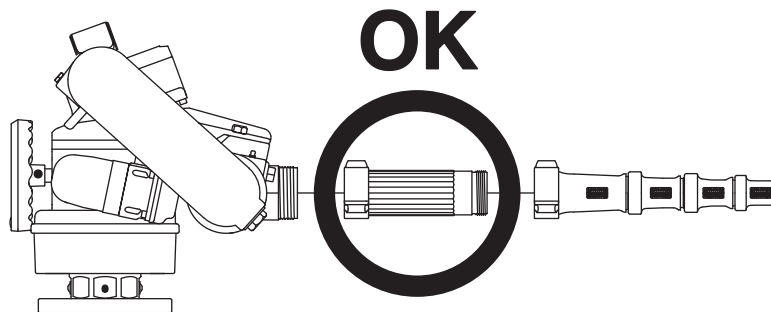

FIG 6.5.3
Hurricane Monitor Friction Loss

6.6 STREAM STRAIGHTENERS

6.6.1 STREAM STRAIGHTENERS WITH STACKED TIP NOZZLES

Stream quality and reach, especially with stacked tip (smooth bore) nozzles, is generally improved with a stream straightener because the water must make many bends before it reaches the nozzle.



6.6.2 STREAM STRAIGHTENERS WITH FOG NOZZLES

When using a fog nozzle, it is recommended that no stream straightener be used since the fog nozzle's flow path generally serves as a stream straightener. Use of a stream straightener with a fog nozzle will increase the stress on the monitor's gear train and may lead to premature wear.

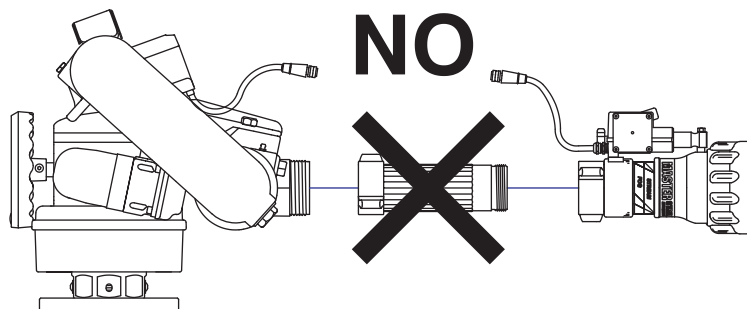

7.0 TROUBLE SHOOTING

SYMPTOM	POSSIBLE CAUSE	REMEDY
Leaks	Debris or damage in seal area	Clean out debris or replace damaged parts
Elevation Binding	Debris or damage to elevation drive parts	Clean out debris or replace damaged parts
	Lack of lubricant	Grease, see section 8.1
Horizontal Rotation Binding	Debris or damage to horizontal drive parts	Clean out debris or replace damaged parts
	Lack of lubricant	Grease, see section 8.1
No Power LED	Polarity reversed	Check wiring and reverse polarity
Power LED On But No Operation	Low voltage due to: - wire gauge too small - wire length too long - poor connection - inadequate apparatus electrical system	Check connections and wiring per section 5.1.2
Operation only from monitor operator station. STOW, & OSC LED's blink when button pressed.	Incorrect wiring	Check blue/white communication wiring
Operation only from monitor control station	Communication board code version incompatible	Verify code versions on monitor and all operator stations
One Axis Fails To Operate From Any Control Station	Loose motor wiring connection	Check axis motor connection
	Bad motor control board	Interchange motor control boards and check if problem persists with same axis, If not, replace motor control board.
	Bad motor	Interchange motor control boards. Check if problem persists with same axis, If yes, replace motor.
	Bad membrane switch	Replace membrane switch / operator station
Vertical/Horizontal axis will not speed up	Loose encoder wiring connection	Check axis encoder connection
	Bad motor encoder	Interchange motor control boards. Check if problem persists with same axis. If yes, replace motor. Remove encoder cover and check for RED light just below disk. If no light, encoder is bad. Replace motor.
Vertical/Horizontal axis runs only in fast speed	Loose encoder wiring connection	Check axis encoder connection
	Bad motor encoder	Interchange motor control boards. Check if problem persists with same axis. If yes, replace motor. Remove encoder cover and check for RED light just below disk. If no light, encoder is bad. Replace motor.
Vertical/Horizontal axis only runs ~5 seconds and then stops.	Loose encoder wiring connection	Check axis encoder connection.
	Bad motor encoder	Interchange motor control boards. Check if problem persists with same axis. If yes, replace motor. Remove encoder cover and check for RED light just below disk. If no light, encoder is bad. Replace motor.

8.0 MAINTENANCE AND INSPECTION

The Hurricane RC monitor requires little maintenance. The monitor should be kept clean and free of dirt. All controls should be checked for freedom of movement and proper operation before each use. Consult factory for recommended service procedure. Any inoperable or damaged parts should be repaired or replaced immediately.

- Make sure that the monitor's handwheels rotate freely and without binding throughout its range of travel.
- Make sure that there are no leaks when the monitor is flowing water.
- Make sure the nozzle is free of debris.

8.1 LUBRICATION

8.1.1 ELEVATION CONTROL WORM GEAR

Turn the hand wheel to raise the nozzle to its highest position and pump medium viscosity automotive chassis grease into the grease fitting on the Elevation worm gear housing until excess appears at the joint. See Fig. 3.2 for grease zerk location.

8.1.2 HORIZONTAL ROTATION WORM GEAR

The Hurricane RC monitor generally should not require greasing in the Horizontal (left-right) worm gear. In the event that the operation becomes stiff, grease may be applied to the horizontal worm gear grease port shown in Fig. 3.2. Use medium viscosity automotive chassis grease. Apply only enough grease to restore normal operation. If greasing does not restore normal operation, inspect for other causes of stiff operation.

Note: Do not over pump grease to Horizontal worm gear. The monitor's Horizontal worm gear greased areas lead to the wire skirt/cable guide that would trap several pounds of grease before becoming visible.

8.2 PERFORMANCE TESTING

Performance tests should be conducted on the Hurricane RC monitor after repairs are made, or any time a problem is reported to verify operation in accordance with Task Force Tips test procedures. Consult the factory for the test procedure that corresponds to the model and serial number of your monitor. Any equipment that fails the test criteria should be removed from service immediately. Equipment can be returned to the factory for service and testing.

9.0 EXPLODED VIEW DRAWINGS AND PARTS LIST

9.1 HURRICANE RC MONITOR ASSEMBLY

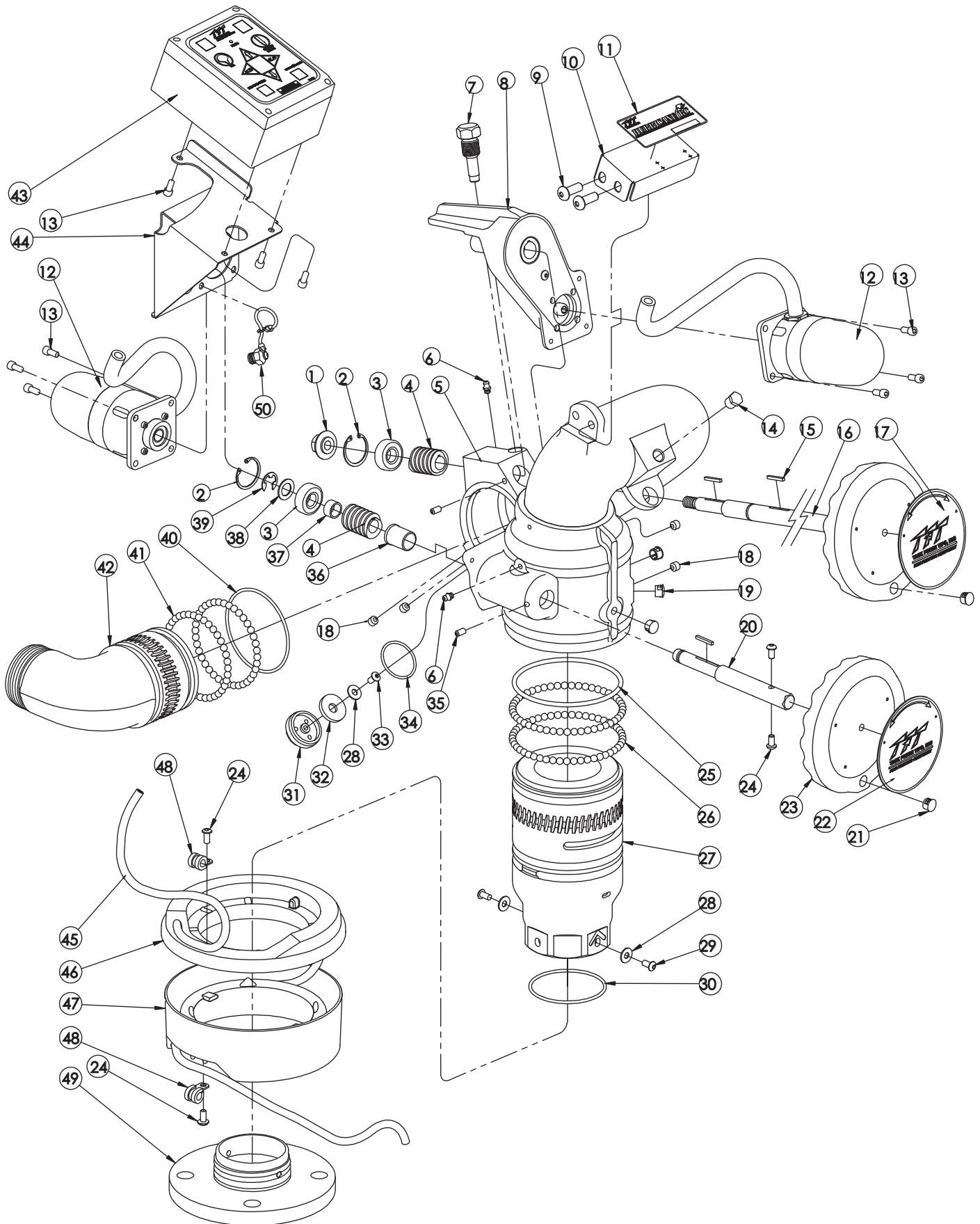

HURRICANE RC MONITOR PARTS LIST

#	DESCRIPTION	QTY	PART #
1	SHAFT NUT	1	X210
2	SNAP RING	2	VR4220
3	BEARING	2	VM4250
4	WORM W/ KEYWAY	2	X220
5	BELL / BIG BEND ASSEMBLY	1	X806
6	GREASE FITTING 1/4-28	2	VT25-28ZERK
7	HEX MOUNTING SCREW	1	X258
8	CHAIN DRIVE ASSEMBLY	1	X888
9	3/8-16 x 1 BHCS	2	VT37-16BH1.0
10	LABEL BRACKET	1	X395
11	LABEL: HURRICANE RC	1	XL300
12	GEAR MOTOR ASSEMBLY	2	Y4950
13	1/4-28 x 1/2 SHCS	9	VT25-28SH500
14	1/4"NPT HEX HEAD PLUG	1	VFHP2M
15	KEY 1/8 x 1.00	3	X225
16	ELEV. SHAFT ASSEMBLY	1	X270
17	LABEL; DOWN <-> UP	1	Y4175
18	3/8-24 x 5/16 SHCS CUP PT.	4	VT37-24SS312
19	DOME PLUG	5	VM4124
20	DRIVE SHAFT	1	Y4160
21	DOME PLUG	2	VM4124
22	LABEL; LEFT <-> RIGHT	1	XL108
23	HANDWHEEL	1	X281
24	1/4-20 x 1/2 BHCS	4	VT25-20BH500
25	O-RING-350	1	VO-350
26	BALL 5/16 TORLON (49)	98	VB.312TO
27	BASE CODE-RLF 3" ALUM	1	Y4405A
28	FLAT WASHER 1/4"	3	VW687X281-50
29	1/4-28 x 1/2 BHCS	2	VT25Y28BH504
30	O-RING-236	1	VO-236
31	DRAIN HOUSING	1	X375
32	DRAIN VALVE	1	X382
33	1/4-20 x 1/2 BHCS	1	VT25-20BH500
34	O-RING-130	1	VO-130
35	1/4-28 x 3/8 SHCS CUP PT.	2	VT25-28SS375
36	HEADED BUSHING	1	Y4141
37	SPACER	1	Y4150
38	SPACER WASHER	1	VW97X595-048
39	E-CLIP 5/8" EXT.	1	VR4295
40	O-RING-241	1	VO-241
41	BALL 5/16" TORLON (38)	76	VB.312TO
42	ELBOW 2.5"NH ALUM SILVER	1	X820NJ-SIL
43	CONTROL BOX - ASMBLY	1	Y5800
44	BOX BRACKET	1	X390
45	CABLE - POWER & COMM.	34 FEET	Y5200
46	UPPER WIRE SKIRT	1	Y4650
47	LOWER WIRE SKIRT	1	Y4660
48	LOOP CLAMP 3/8"	2	Y4655
49	FLANGE 3"ANSI 150 ALUM	1	Y4410A
50	PLUG CAP W/ CHAIN ASMBLY.	1	Y5340

9.2 ELEVATION CHAIN DRIVE ASSEMBLY

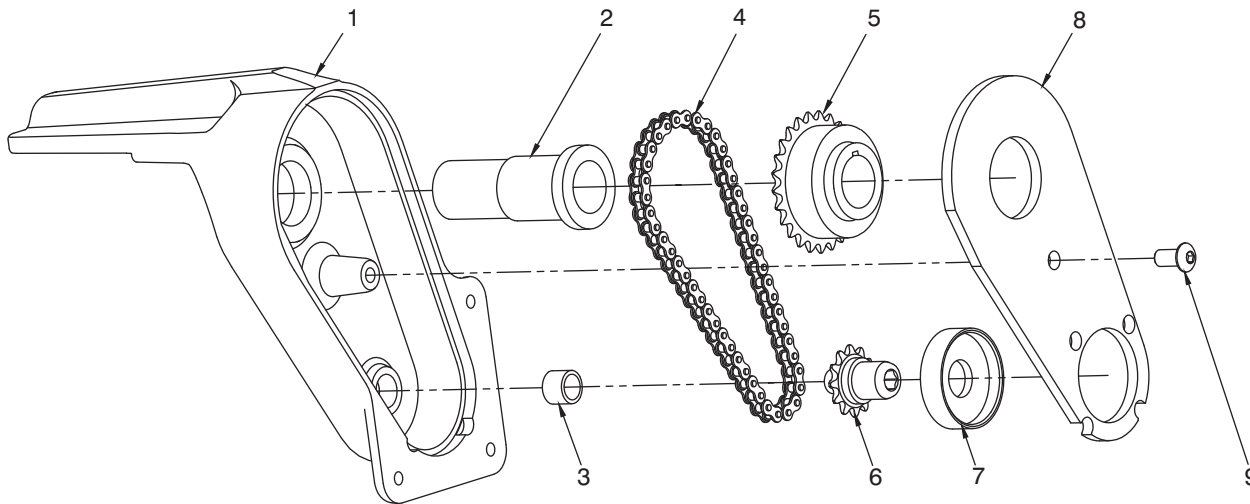

#	DESCRIPTION	QTY	PART #
1	HOUSING	1	X250
2	BUSHING - SHAFT	1	X251
3	BUSHING - DRIVE	1	X252
4	ROLLER CHAIN RING	1	X255
5	SPROCKET - SLAVE	1	X254
6	SPROCKET - DRIVE	1	X253
7	BUSHING - MOTOR	1	X256
8	COVER	1	X257
9	1/4-28 x 1/2 BHCS	1	VT25-28BH500

9.3 GEAR MOTOR ASSEMBLY

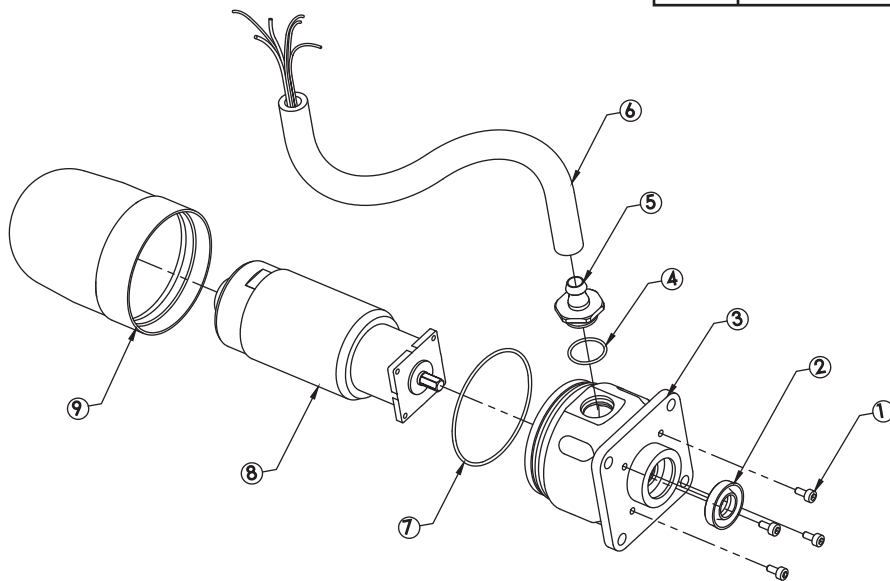

#	DESCRIPTION	QTY	PART #
1	6-32 x 5/16 LONG SHCS WITH HEAD SEAL	4	VT06S32SH312
2	CUP SEAL 1.0625 x .5625 x 1/4	1	Y4620
3	MOTOR SOCKET	1	Y4615
4	O-RING-018	1	VO-018
5	CONDUIT FITTING	1	Y5213
6	HOSE - 3/8" ID PUSH-LOK	1	Y5250
7	O-RING-038	1	VO-038
8	GEAR MOTOR WITH ENCODER	1	Y4610
9	ENCLOSURE	1	Y4616

9.4 MONITOR CONTROL BOX ASSEMBLY

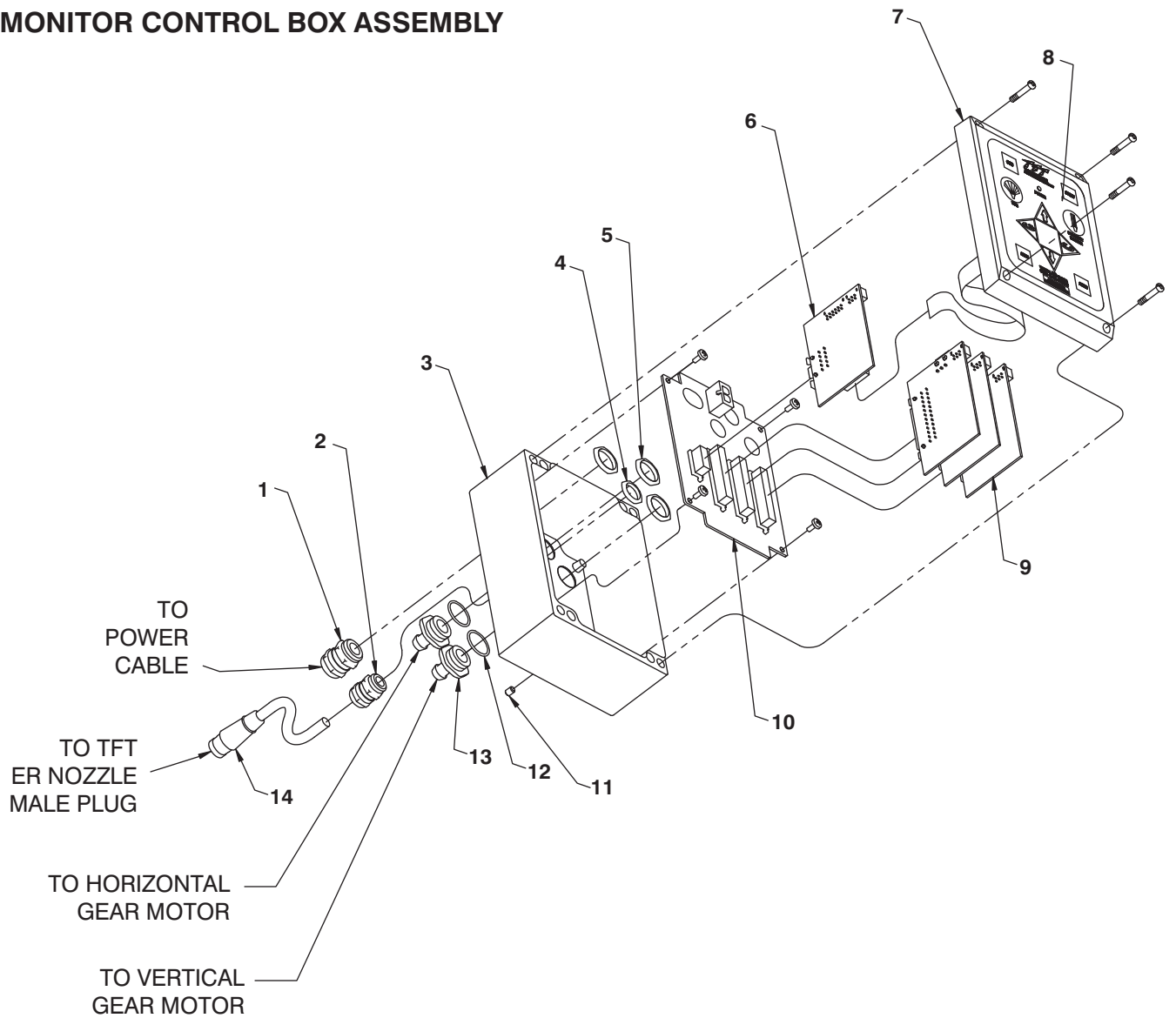

#	DESCRIPTION	QTY.		PART NO.
1	CABLE FITTING PG11	1		Y5205
2	CABLE FITTING PG9	1		Y5245
3	ENCLOSURE - BOX	1		Y5115
4	LOCKNUT - PG9	1		Y5246
5	LOCKNUT - PG11	3		Y5206
6	BOARD - COMMUNICATION	1		Y5110
7	ENCLOSURE - LID	1		Y5115
8	CONTROL SWITCH PAD	1		Y5700
9	BOARD - MOTOR CONTROL	3		Y5100
10	BOARD - MAIN	1		Y5105
11	V10-32 x 1/4 SET SCREW	1		VT10Y32SS250
12	O-RING-018	2		VO-018
13	CONDUIT HOSE FITTING	2		Y5213
14	FEMALE PLUG - 2 POLE FOR HURRICANE RC NOZZLE CONNECTION	10.0" TOTAL LENGTH USED	5.0" EXPOSED CABLE (NOT INCLUDING PLUG)	Y5280

10.0 WARRANTY

Task Force Tips, Inc., Valparaiso, Indiana 46383-6940 ("TFT") warrants to the original purchaser of its Hurricane RC Monitor("equipment"), and to anyone to whom it is transferred, that the equipment shall be free from defects in material and workmanship during the five (5) year period from the date of purchase.

TFT's obligation under this warranty is specifically limited to replacing or repairing the equipment (or its parts) which are shown by TFT's examination to be in a defective condition attributable to TFT. To qualify for this limited warranty, the claimant must return the equipment to TFT, at 2800 East Evans Avenue, Valparaiso, Indiana 46383-6940, within a reasonable time after discovery of the defect. TFT will examine the equipment. If TFT determines that there is a defect attributable to it, it will correct the problem within a reasonable time. If the equipment is covered by this limited warranty, TFT will assume the expenses of repair.

If any defect attributable to TFT under this limited warranty cannot be reasonably cured by repair or replacement, TFT may elect to refund the purchase price of the equipment, less reasonable depreciation, in complete discharge of its obligations under this limited warranty. If TFT makes this election, claimant shall return the equipment to TFT free and clear of any liens and encumbrances.

This is a limited warranty. The original purchaser of the equipment, any person to whom it is transferred, and any person who is an intended or unintended beneficiary of the equipment, shall not be entitled to recover from TFT any consequential or incidental damages for injury to person and/or property resulting from any defective equipment manufactured or assembled by TFT. It is agreed and understood that the price stated for the equipment is in part consideration for limiting TFT's liability. Some states do not allow the exclusion or limitation of incidental or consequential damages, so the above may not apply to you.

TFT shall have no obligation under this limited warranty if the equipment is, or has been, misused or neglected (including failure to provide reasonable maintenance) or if there have been accidents to the equipment or if it has been repaired or altered by someone else.

THIS IS A LIMITED EXPRESS WARRANTY ONLY. TFT EXPRESSLY DISCLAIMS WITH RESPECT TO THE EQUIPMENT ALL IMPLIED WARRANTIES OF MERCHANTABILITY AND ALL IMPLIED WARRANTIES OF FITNESS FOR A PARTICULAR PURPOSE. THERE IS NO WARRANTY OF ANY NATURE MADE BY TFT BEYOND THAT STATED IN THE DOCUMENT.

This limited warranty gives you specific legal rights, and you may also have other rights which vary from state to state.

TASK FORCE TIPS, Inc.
MADE IN USA • www.tft.com

2800 E. Evans Ave., Valparaiso, IN 46383-6940 USA
800-348-2686 • 219-462-6161 • Fax 219-464-7155