



Truck Mount Adapter - XFF-APL
Flange Truck Mount Adapter - XFF-MPL
XFF-MPP

The XFF-APL Truck Mount Adaptor will connect the CROSSFIRE® monitor to a riser pipe with a 3" NPT male thread. The XFF-MPL Truck Mount Adapter will connect a CROSSFIRE® monitor to a riser pipe with either a 3" ANSI 150 lb ASA flange or 3" NPT male threads. The XFF-MPP Truck Mount Adaptor will connect a CROSSFIRE® monitor to a riser pipe with either 4" ANSI 150 flange or 4" NPT male threads.



Read instruction manual before use. Operation of this device without understanding the manual and receiving proper training is a misuse of this equipment. Users who have not read and understood all operating and safety instructions are not qualified to operate this portable/deck gun.



Injury can occur from an inadequately supported monitor. The mounting must be capable of supporting the nozzle reaction force which can be as high as 950 lbs. (1250 GPM at 175 PSI). Flanges and pipe made from plastic are inadequate for monitor mounting and must not be used.

Make sure that there is no interference between monitor and other deck mounted equipment in all directions.

A drain valve should be provided in the riser pipe which supplies the monitor. The riser should be drained immediately after each use during cold weather to prevent freezing and possible damage.

The Crossfire monitor has an automatic drain. If this drain has been deactivated, the monitor must be drained by lowering the nozzle below horizontal.

Use pipe thread sealant on the riser pipe threads when installing the XFF-APL or using the internal threads of the XFF-MPL or XFF-MPP adapters. When installing the bolted flanges, use the supplied ring gasket.

If you have any questions or installation difficulties, please call 1.800.348.2686.

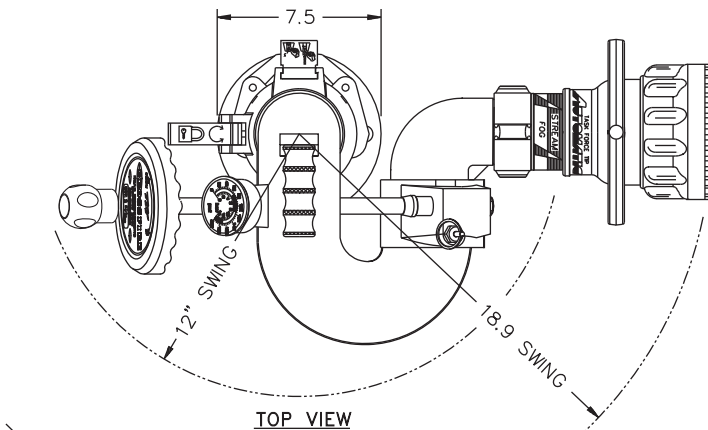

XFF-MPL

Model	Flange Thickness	Flange Height	# of Bolts	Bolt Dia	Torque on Bolts
XFF-MPL	.75 in 19mm	5 in 127mm	4	5/8 in	76-80 ft-lbf

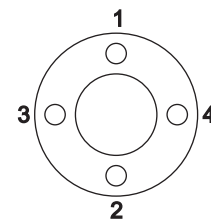

Tighten sequentially each bolt three times.
 Flange Bolt Tightening Sequence

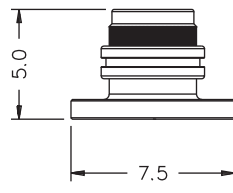

FLANGE MOUNT
 (PART #XFF-MPL)

FLANGE SPECS:
 (4) 5/8" BOLTS
 ON A 6.00 B.H.C.
NOMINAL SIZE:
 3" ASA 125 LBS
 (ALSO HAS 3"
 FEMALE TAPER
 PIPE THREADS)

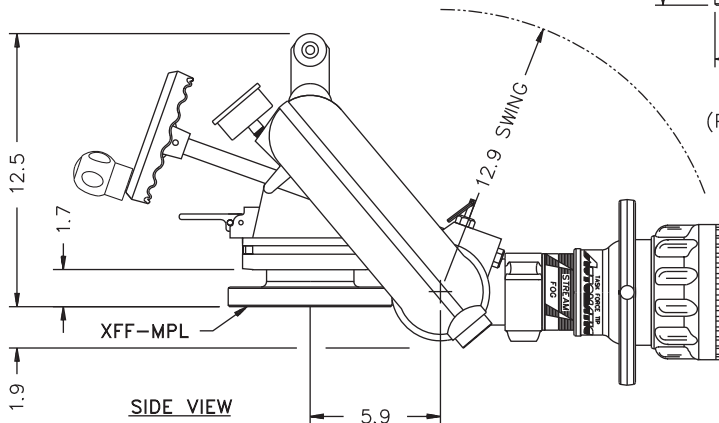

SIDE VIEW

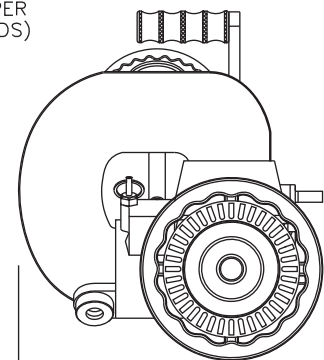

FRONT VIEW

TASK FORCE TIPS, Inc.
 MADE IN USA • www.tft.com

3701 Innovation Way, Valparaiso, IN 46383-9327 USA
 800-348-2686 • 219-462-6161 • Fax 219-464-7155



Truck Mount Adapter - XFF-APL
Flange Truck Mount Adapter - XFF-MPL
XFF-MPP

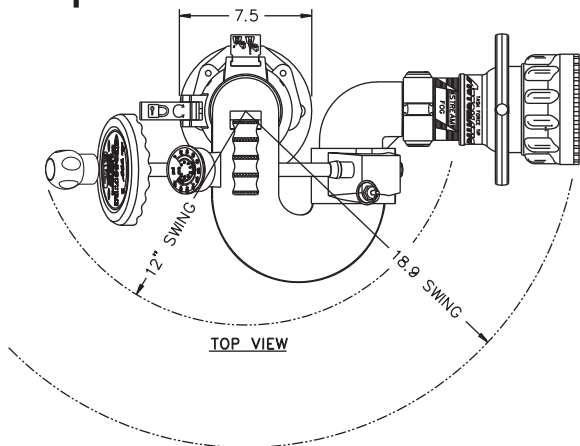

TOP VIEW

XFF-MPP

Model	Flange Thickness	Flange Height	# of Bolts	Bolt Dia	Torque on Bolts
XFF-MPP	.94 in 24mm	7.9 in 200.5mm	8	5/8 in	76-80 ft-lbf

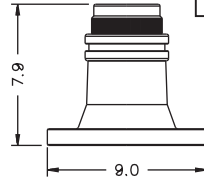

FLANGE MOUNT
(PART #XFF-MPP)

FLANGE SPECS:
 (8) 5/8" BOLTS
 ON A 7.50 B.H.C.
 NOMINAL SIZE:
 4" ASA 150 LBS
 (ALSO HAS 4"
 FEMALE TAPER
 PIPE THREADS)

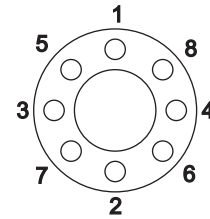

Tighten sequentially each bolt three times.
 Flange Bolt Tightening Sequence

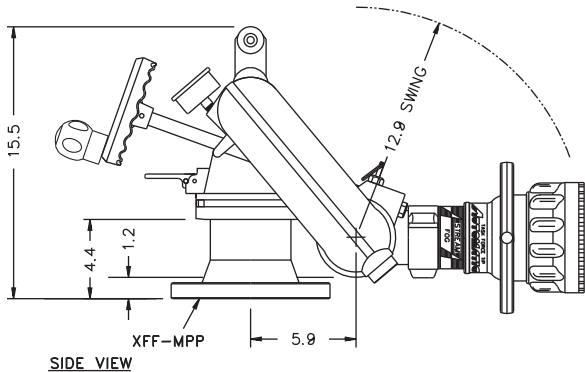

SIDE VIEW

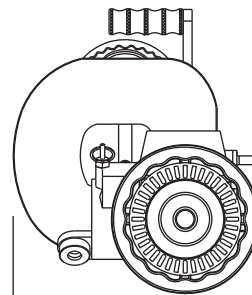

FRONT VIEW

DWGS/TFT/MONITOR/FLGVWHORIZ
 9/13/99 RJM

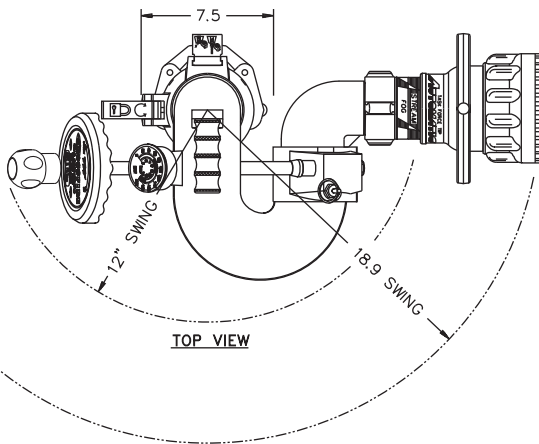

TOP VIEW

XFF-APL

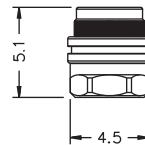

TRUCK MOUNT
(PART #XFF-APL)

THREAD SPECS:
 3" FEMALE
 TAPER PIPE THREADS

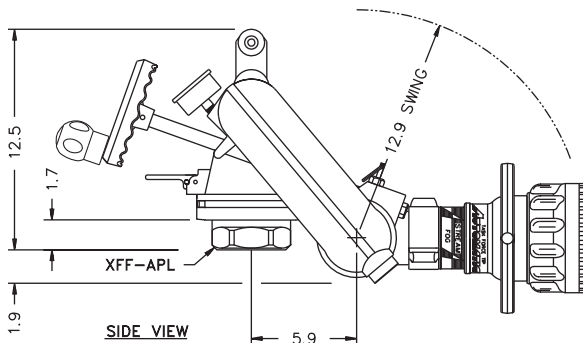

SIDE VIEW

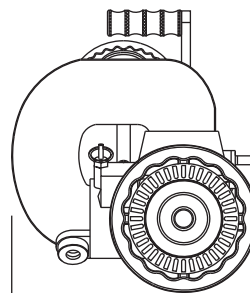

FRONT VIEW

TASK FORCE TIPS, Inc.
 MADE IN USA • www.tft.com

3701 Innovation Way, Valparaiso, IN 46383-9327 USA
 800-348-2686 • 219-462-6161 • Fax 219-464-7155