



MANUAL: CROSSFIRE Monitor With Stow-A-Way 800 Base

INSTRUCTIONS FOR SAFE OPERATION AND MAINTENANCE

⚠ DANGER

Understand manual before use. Operation of this device without understanding the manual and receiving proper training is a misuse of this equipment. Obtain safety information at www.tft.com/serial-number.

⚠ DANGER

Risk of sliding increases at low elevation angles. To reduce risk of injury or death from sliding, do not pull elevation pin stop while on portable base.

This Instruction Manual is intended to familiarize firefighters and maintenance personnel with the operation, servicing, and safety procedures associated with the portable monitor.

This manual should be kept available to all operating and maintenance personnel.

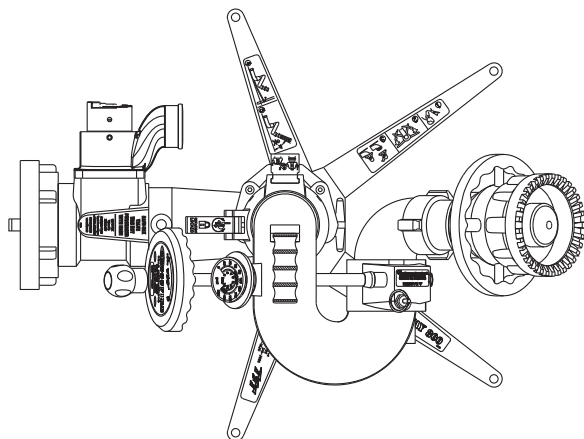
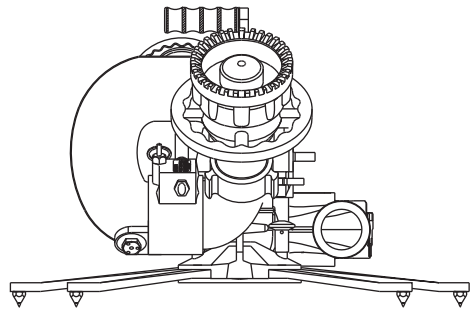
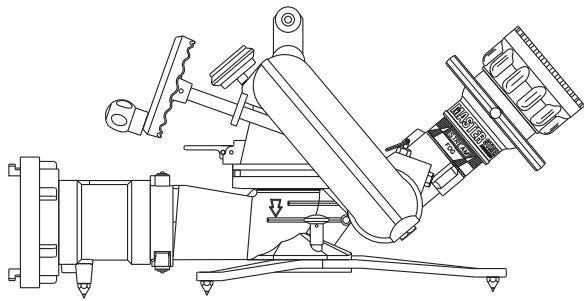

**See Section 4.10.5
For Flow/Pressure
Operating Envelope**

TASK FORCE TIPS, INC.
MADE IN USA • www.tft.com

3701 Innovation Way, Valparaiso, IN 46383-9327 USA
800-348-2686 • 219-462-6161 • Fax 219-464-7155



PERSONAL RESPONSIBILITY CODE

The member companies of FEMSA that provide emergency response equipment and services want responders to know and understand the following:

1. Firefighting and Emergency Response are inherently dangerous activities requiring proper training in their hazards and the use of extreme caution at all times.
2. It is your responsibility to read and understand any user's instructions, including purpose and limitations, provided with any piece of equipment you may be called upon to use.
3. It is your responsibility to know that you have been properly trained in Firefighting and /or Emergency Response and in the use, precautions, and care of any equipment you may be called upon to use.
4. It is your responsibility to be in proper physical condition and to maintain the personal skill level required to operate any equipment you may be called upon to use.
5. It is your responsibility to know that your equipment is in operable condition and has been maintained in accordance with the manufacturer's instructions.
6. Failure to follow these guidelines may result in death, burns or other severe injury.



Fire and Emergency Manufacturers and Service Association
P.O. Box 147, Lynnfield, MA 01940 • www.FEMSA.org

Table Of Contents

- 1.0 MEANING OF SAFETY SIGNAL WORDS
- 2.0 SAFETY
- 3.0 GENERAL INFORMATION
 - 3.1 VARIOUS MODELS AND TERMS
 - 3.2 SPECIFICATIONS
 - 3.2.1 MECHANICAL
- 4.0 CROSSFIRE DEPLOYMENT
 - 4.1 QUICK CONNECT SWIVEL JOINT
 - 4.2 INSTALLING MONITOR ON BASE
 - 4.3 REMOVING MONITOR TOP FROM BASE
 - 4.4 SIDE-TO-SIDE ROTATION AND ROTATION LOCK
 - 4.5 ELEVATION CONTROL AND STOP PIN
 - 4.6 AUTOMATIC DRAIN
 - 4.7 TRUCK MOUNT BASE
 - 4.8 TRUCK MOUNTING OF THE PORTABLE BASE
 - 4.9 CROSSFIRE® USAGE
 - 4.10 FLOWS AND PRESSURES
 - 4.10.1 STACKED TIPS
 - 4.10.2 AUTOMATIC MASTER STREAM NOZZLES
 - 4.10.3 STREAM STRAIGHTENERS
 - 4.10.4 PRESSURE LOSS
 - 4.10.5 OPERATING ENVELOPE
 - 4.11 TRANSPORTING MONITOR ON TRUCK MOUNT BASE
- 5.0 STOW-A-WAY 800 BASE
 - 5.1 SITE SELECTION
 - 5.2 EXTENDING PORTABLE LEGS
 - 5.3 RETRACTING PORTABLE BASE LEGS
 - 5.4 PORTABLE BASE LEG SPIKES
 - 5.5 PORTABLE BASE ANCHORING
 - 5.6 ADDING A FLOW SAFELY VALVE
 - 5.7 HOSE CONNECTION
 - 5.8 PRESSURE RELIEF OPTION
 - 5.9 PRESSURE RELIEF VALVE SETTING
- 6.0 PORTABLE BASE STORAGE
 - 6.1 STORAGE BRACKET
 - 6.1.1 INSTALLATION INSTRUCTIONS FOR BLIND MOUNTING
 - 6.1.2 INSTALLATION INSTRUCTIONS WHERE BACK OF MOUNTING SURFACE IS ACCESSIBLE
- 7.0 APPROVALS
- 8.0 DRAWINGS AND PART LISTS
 - 8.1 MONITOR DRAWING AND PART LIST
 - 8.2 STOW-A-WAY 800 DRAWING AND PART LIST
 - 8.3 VALVE UPGRADE KIT (XF500-KIT) DRAWING AND PART LIST
 - 8.4 HIGH FLOW INLET OPTION
 - 8.5 DOUBLE INLET OPTION
- 9.0 WARRANTY
- 10.0 ANSWERS TO YOUR QUESTIONS
- 11.0 MAINTENANCE
 - 11.1 GREASING THE WORM GEAR
 - 11.2 SERVICE TESTING
 - 11.2.1 HYDRAULIC TEST
 - 11.2.2 RELIEF VALVE TEST
 - 11.2.3 SHUTOFF VALVE TEST
 - 11.2.4 RECORDS
 - 11.3 REPAIR
- 12.0 OPERATION and INSPECTION CHECKLIST

1.0 MEANING OF SAFETY SIGNAL WORDS

A safety related message is identified by a safety alert symbol and a signal word to indicate the level of risk involved with a particular hazard. Per ANSI standard Z535.6-2011, the definitions of the four signal words are as follows:



DANGER indicates a hazardous situation which, if not avoided, will result in death or serious injury.



WARNING indicates a hazardous situation which, if not avoided, could result in death or serious injury.



CAUTION indicates a potentially hazardous situation which, if not avoided, could result in minor or moderate injury.



NOTICE is used to address practices not related to physical injury.

2.0 SAFETY

⚠ DANGER

An inadequate supply of nozzle pressure and/or flow will cause an ineffective stream and can result in injury, death, or loss of property. See flow graphs in section 3.0 or call 800-348-2686 for assistance.

⚠ DANGER

Low nozzle elevation angles can cause portable monitors to slide or lift off the ground which can result in injury or death. Do not operate the monitor on the portable base below the elevation safety stop.

⚠ DANGER

An out of control monitor can cause injury or death. To reduce the risk of instability, do not attempt to move the monitor with water flowing.

⚠ WARNING

Injury can occur from an inadequately supported monitor. When the monitor is used on a truck the mounting must be capable of supporting 900 lbs (400 KG) of nozzle reaction force. Note: the storage bracket is intended for storage of the monitor only. It is not strong enough to withstand the forces of monitor operation. Flanges and pipe made from plastic are inadequate for monitor mounting and must not be used.

⚠ WARNING

A sliding monitor can cause injury. To protect against sliding:

- make sure the base legs are locked in position with all leg spikes in contact with the ground.
- securely tie the monitor to an object capable of withstanding 900 lbs (400 kg) of force.
- use additional tie downs on hard surfaces such as concrete, asphalt, and metal.
- avoid lifting the monitor when moving the hoses around it.

⚠ WARNING

This equipment is intended for use by trained personnel for firefighting. Their use for other purposes may involve hazards not addressed by this manual. Seek appropriate guidance and training to reduce risk of injury.

⚠ WARNING

The flow from the monitor may be vital to keep a firefighter from injury or death. Avoid situations that may interrupt flow to the monitor such as: hose line kinks, traffic running over hose, and automatic doors or devices that can pinch the hose.

⚠ WARNING

Some volatile liquids can be ignited by static discharge. Static build-up can occur from:

- Electrochemical separation of charge as water drains through low conductivity, refined products.
- Applying foam over a low conductivity liquid of sufficient depth to retain the charge created as the foam blanket drains.
- Streaming currents as water or foam is introduced into the storage tank.¹

¹ Electrostatic Hazards of Foam Blanketing Operations by Peter Howels. Industrial Fire Safety July/August 1993

² The Fire Fighter and Electrical Equipment, The University of Michigan Extension Service, Fourth Printing 1983. Page 47

⚠ CAUTION

Master streams are powerful and capable of causing injury and property damage. Make sure the monitor is pointing in a safe direction before water to the nozzle is turned on. Use care in directing the stream.

⚠ CAUTION

Monitor must be properly connected to a hose and nozzle with matched threads. Mismatched or damaged threads may cause leaking or uncoupling under pressure and could cause injury.

⚠ CAUTION

Dissimilar metals coupled together can cause galvanic corrosion that can result in the inability to unscrew the threads or complete loss of thread engagement over time. Per NFPA 1962, if dissimilar metals are left coupled together an anti-corrosive lubricant should be applied to the threads. Also the coupling should be disconnected and inspected at least quarterly.

NOTICE

To prevent mechanical damage, do not drop or throw equipment.

3.0 GENERAL INFORMATION

The CROSSFIRE monitor is the most rugged and innovative deck/portable master stream device ever offered to the fire service. Attachment of the CROSSFIRE to the base is quick, easy, positive, and can be visually verified. The release mechanism is locked out by water pressure. The rotation lock is a simple lever which securely holds the CROSSFIRE monitor in position. An automatic drain allows water to drain from the monitor when not in use.

3.1 VARIOUS MODELS AND TERMS

The CROSSFIRE Portable Monitor is an efficient, compact and easy to maneuver portable monitor. This monitor can be mounted in a pre-connected state on the truck-mounting bracket for achieving quick and effective initial attack.

The CROSSFIRE monitor is available in several different models and inlet connections. Figures 3.1.1, 3.1.2, & 3.1.3 show the CROSSFIRE monitor, STOW-A-WAY 800 portable base, truck mount adaptor and identifies the various parts and controls.

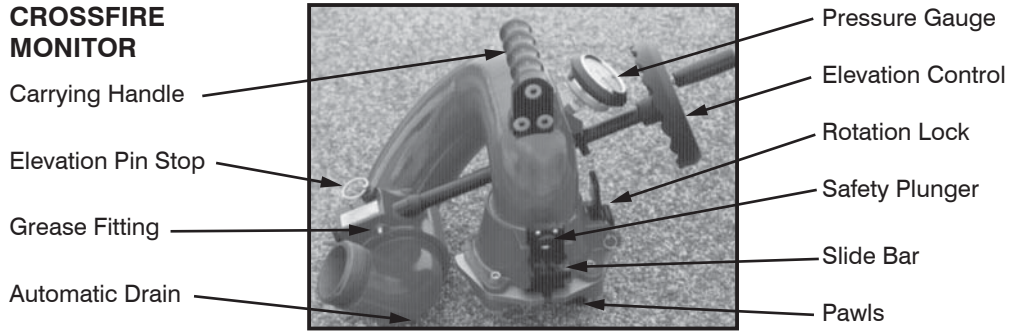

Figure 3.1.1

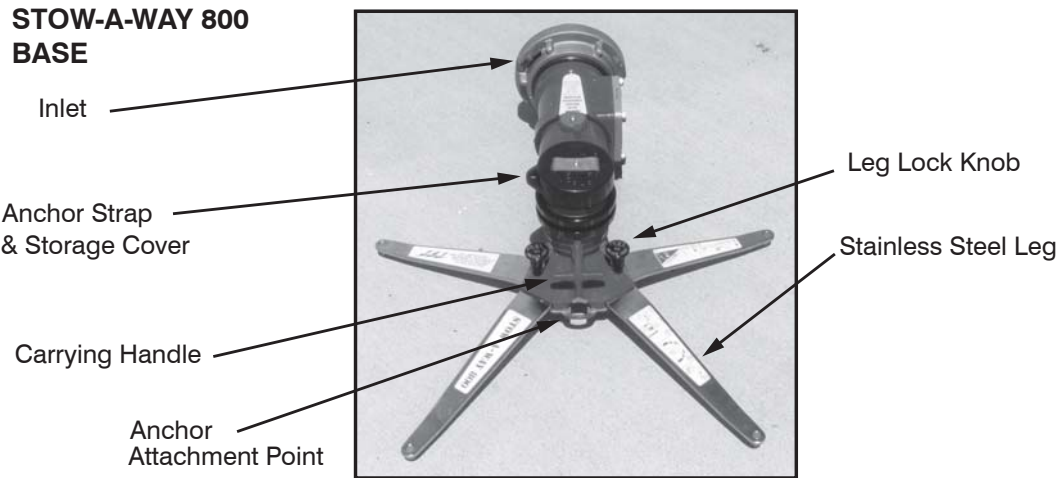

Figure 3.1.2

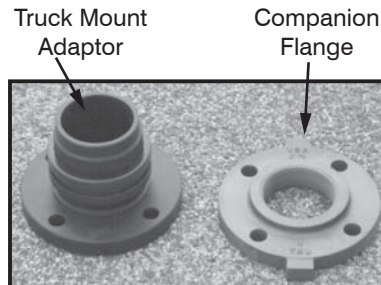

Figure 3.1.3

3.2 SPECIFICATIONS

3.2.1 MECHANICAL

	CROSSFIRE Monitor	STOW-A-WAY 800 Base*
Weight	17 lbs 6.7 kg	20.7 lbs 9.4 kg
Storage Volume	4060 in ³ .066m ³	1620 in ³ .027m ³
L-W-H	20" x 14-1/2" x 14" .51 x .37 x .36m	20" x 9" x 9" .51 x .23 x .23m
Height Above Truck Flange	12-1/2 in 320mm	NA
Height Above Truck Deck (min)	14 in 360mm	NA
Height Above Ground on Base	16-1/2 in 420mm	NA
Line of Reaction Force Above Ground	4 in 100mm	NA
Flow Area (minimum)	8.3 in ² 5360mm ²	8.3 in ² 5360mm ²
Materials Used	Cast Aluminum, Aluminum, Stainless Steel	Cast Aluminum, Aluminum, Stainless Steel
Inlets Available	One	Numerous Single & Double Inlets 2-1/2" - 6"
Operating Temperature Range of Fluid	33 to 120° F 1 to 50° C	33 to 120° F 1 to 50° C
Storage Temperature Range	-40 to 150° F -40 to 65° C	-40 to 150° F -40 to 65° C

Dimensions shown for STOW-A-WAY 800 portable base with double inlet 2-1/2" model.

4.0 CROSSFIRE DEPLOYMENT

The CROSSFIRE monitor can be used on either a truck mount adaptor, Extend-A-Gun or portable base. Installation on either base makes use of a quick connect swivel joint. The use of each base and the quick connect joint is explained in the following sections.

4.1 QUICK CONNECT SWIVEL JOINT

Two pawls, actuated by the slide bar, engage in the base swivel to make the quick connect joint. A safety plunger engages in the slide bar to prevent accidental unlocking of the slide bar when the monitor is under pressure.

4.2 INSTALLING MONITOR ON BASE

To install the monitor on either the truck mount flange or portable base: Refer to figures 4.2.1, 4.2.2, & 4.2.3.

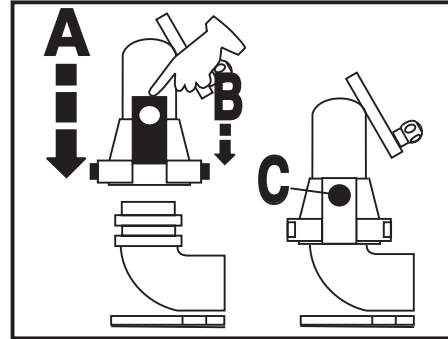

Figure 4.2.1

A) Turn elevation handwheel to make sure the elevation of the nozzle is above the 35° safety stop. Verify that the elevation stop pin is down and engaged. Make sure the slide bar is in the up position.

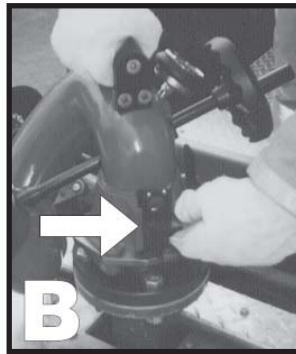

Figure 4.2.2

B) Hold the monitor by the top carrying handle, position monitor over base and slide straight down.

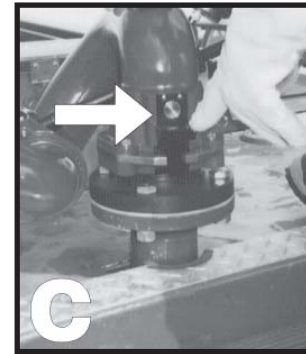

Figure 4.2.3

C) Push the slide bar down, watch the pawls engage the groove in the base and the safety plunger engage in the hole in the slide bar.

4.3 REMOVING MONITOR TOP FROM BASE

To remove the monitor from its base:

- Stop all water flow.
- Depress the safety plunger and lift the slide bar which will disengage the spring loaded pawls from the groove in the base.
- Lift the monitor straight up off the base by the handle on top of the monitor.

4.4 SIDE-TO-SIDE ROTATION AND ROTATION LOCK

Side-to-side rotation is accomplished by rotating the monitor on its base. The rotational position can be locked by moving the rotation lock lever to its down position as shown in Figures 4.4.1 & 4.4.2. Before the monitor is removed from the base, the rotation lock should be manually disengaged. A small spring holds the rotational lock in the unlocked position. When not rotating the monitor on the base, keep the rotation lock locked.



Figure 4.4.1
Unlocked



Figure 4.4.2
Locked

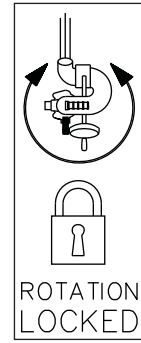

⚠ WARNING A sliding monitor can cause injury. When used on a portable base, keep the horizontal angle between the water stream and the anchor strap as small as possible. At large angles the base can slide in an arc around the anchor point.

4.5 ELEVATION CONTROL AND STOP PIN

When a nozzle is flowing water the reaction force acts in a straight line that is directly opposite the water flowing out the end of the nozzle. If a nozzle on a monitor on a portable base is pointed straight up, all of the reaction force is directed straight down and there is no sideways force that can cause the base to slide. As the nozzle is angled downward at the same flow, the reaction force remains the same, but some of that force becomes a force acting sideways and some acts in a downward direction. When the nozzle is at an angle of 45° the force acting sideways is equal to the force acting downward on the base. As the elevation angle of the nozzle is lowered the sideways force increases while the downward force decreases. At an angle of 35°, (the angle at the elevation safety stop), approximately 82% of the nozzle reaction force is acting sideways on the base. When the nozzle is at a zero degree angle, with respect to the base, the entire reaction force is acting sideways on the base and there is no downward force at all. The lower the elevation angle of the nozzle, with respect to the base, the greater the force that causes sliding, and the more likely sliding will occur.



Figure 4.5.1
Elevation control



Figure 4.5.2
Elevation stop pin out



Figure 4.5.3
Elevation stop pin in

⚠ DANGER
Operating On Portable Base Below This Stop (pin pulled) Is Dangerous.

XL090

⚠ DANGER Operating on a portable base below this safety stop is DANGEROUS. Injury or death can occur if the monitor and base slides or lifts off the ground. Do not operate on portable base below safety stop.

When mounted on a truck base, the nozzle may be lowered below the 35° safety stop by pulling out the stop pin and rotating the handwheel below the 35° stop. When the nozzle is raised back above 35°, the spring loaded stop pin will snap back into position automatically limiting the elevation of the nozzle with respect to the base to 35°.

4.6 AUTOMATIC DRAIN

An automatic drain empties water from a low point in the monitor piping to prevent freezing and help empty hose lines. The valve is designed to close automatically when pressure in the monitor exceeds approximately 5 psi and open again when the pressure drops to that point. When the automatic drain is not desirable it may be disabled. To disable the drain valve refer to the exploded view on page 16 and follow the steps below:

- 1) Unscrew the drain assembly (40, 41, 42, & 43) and remove the screw and washer (42 & 43)
- 2) Flip over the rubber drain valve (41) so that the raised edge is against the face of the housing (40).
- 3) Reassemble

4.7 TRUCK MOUNT BASE

The CROSSFIRE® monitor may be used from a truck by using a truck mount adapter. The truck mount adapter can be bolted to the riser pipe with a 3" ANSI 150# or 4" ANSI 150# companion flange and gasket using 5/8" bolts. It can also be screwed directly on a male pipe thread. Use of pipe thread sealant is recommended. The riser must be supported to safely withstand a nozzle reaction force of up to 900 lbs (400 KG). Make sure that no interference exists between the monitor and other deck mounted equipment in any direction. See truck mount base installation instructions for details, document #LIX-045.

A drain valve should be provided in the riser pipe which supplies the monitor. The riser should be drained immediately after each use during cold weather to prevent freezing and possible damage. The monitor has an automatic drain. If this drain has been disabled (see section 4.6), the monitor must be drained by lowering the nozzle below horizontal. Installation instructions are supplied with the truck mount base.

4.8 TRUCK MOUNTING OF THE PORTABLE BASE

In some cases a user may not have a riser directly off of the pump that can be used for mounting the monitor. In this case it may be desirable to supply the monitor with hose lines connected to the side discharge of the pumper. In these circumstances it is recommended that the user purchase a Deck Mount Plate, TFT part XF400-KIT, from the manufacturer. Please call 1-800-348-2686 for further information and advice concerning mounting alternatives. Installation instructions are shipped with this accessory. The storage bracket, TFT part XF-B, for the base unit IS NOT STRONG ENOUGH to withstand the forces encountered with an operating monitor and is not intended for this purpose.

4.9 CROSSFIRE® USAGE

Because of the arched trajectory of a fire stream, it is recommended that a spotter be used to accurately direct the stream from the monitor. Master streams flows are powerful and capable of injury and damage to property. Use great care in directing the stream.

4.10 FLOWS & PRESSURES

4.10.1 STACKED TIPS

NOZZLE DIAMETER	NOZZLE PRESSURE									
	50 PSI		80 PSI		100 PSI		150 PSI		175 PSI	
	FLOW (GPM)	REACTION (LBS)	FLOW (GPM)	REACTION (LBS)	FLOW (GPM)	REACTION (LBS)	FLOW (GPM)	REACTION (LBS)	FLOW (GPM)	REACTION (LBS)
1-3/8"	400	150	500	240	560	300	680	440	730	520
1-1/2"	470	180	600	280	660	350	810	520	870	620
1-3/4"	640	240	810	380	910	480	1100	712	1190	840
2"	840	310	1060	500	1190	630	—	—	—	—

Flow exceeds rating of portable base. Use only when monitor is truck mounted.

Flow exceeds rating of truck mounted monitor.

NOZZLE DIAMETER (MM)	NOZZLE PRESSURE									
	3.5 BAR		5.5 BAR		7 BAR		10 BAR		12 BAR	
	FLOW (L/min)	REACTION (KG)	FLOW (L/min)	REACTION (KG)	FLOW (L/min)	REACTION (KG)	FLOW (L/min)	REACTION (KG)	FLOW (L/min)	REACTION (KG)
35	1500	70	1900	110	2200	140	2600	200	2800	240
38	1800	80	2300	130	2500	160	3000	230	3300	280
44	2400	110	3000	170	3400	220	4100	310	4500	370
50	3100	140	3900	220	4400	280	—	—	—	—

Flow exceeds rating of portable base. Use only when monitor is truck mounted.

Flow exceeds rating of truck mounted monitor.

4.10.2 AUTOMATIC MASTER STREAM NOZZLES

Automatic nozzles maintain a constant pressure by adjusting their opening to match the available flow. Consult the nozzle manufacturer for maximum flow and pressure ratings. In all cases, do not exceed the operating envelope.

4.10.3 STREAM STRAIGHTENERS

Stream quality, especially with smooth bore nozzles, is generally improved with a stream straightener because the water must make many bends passing through a monitor.

4.10.4 PRESSURE LOSS

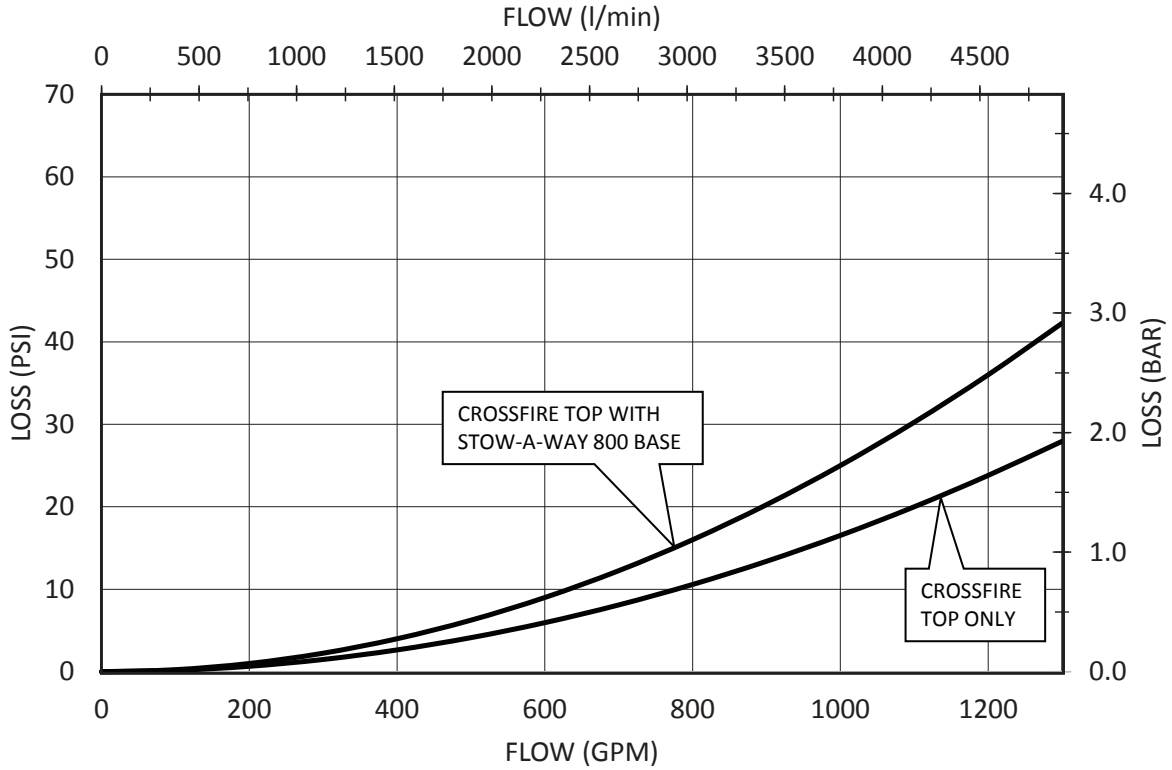

4.10.5 OPERATING ENVELOPE

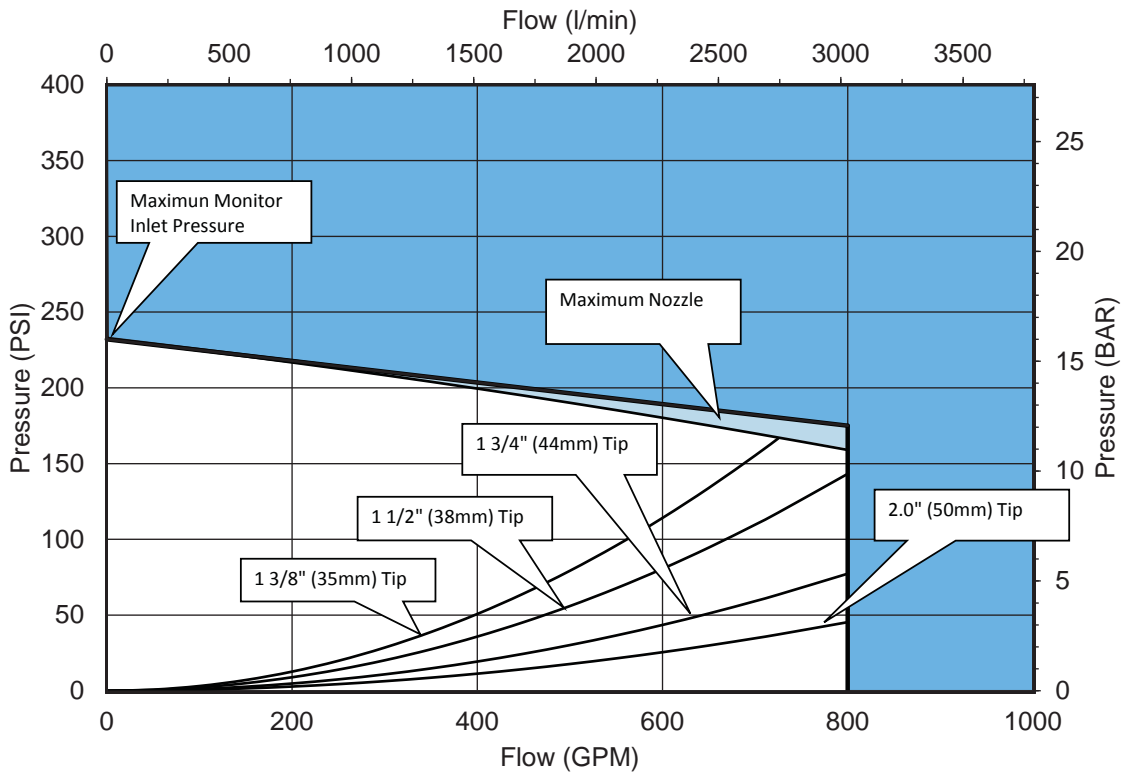

4.11 TRANSPORTING MONITOR ON TRUCK MOUNT BASE

If the monitor is to be transported on a truck mount base, the horizontal lock should be kept locked to keep the monitor from spinning on its base. The rotational position can be locked by moving the rotation lock lever to its down position. The nozzle may be supported by a bracket or pointed straight up.

5.0 STOW-A-WAY 800 BASE

The portable base allows the monitor to be positioned in places that are not accessible with a fire truck. The legs are made of stainless spring steel and will flex when in use to compensate for small ground irregularities. It is intended for maximum flows of 800 gpm (3000 l/min).

5.1 SITE SELECTION

Safe operation of the monitor on the portable base begins with site selection. The site should be a safe distance from the fire yet within reach of the nozzle stream. Select a flat even surface within 8 feet of a sturdy stationary object that can be used as an attachment point for the anchor strap. Set up the portable base with the anchor point between the portable base and desired target of the nozzle stream.

5.2 EXTENDING PORTABLE BASE LEGS

The portable base legs are extended by following these steps:

(Refer to figures 5.2.1, 5.2.2, & 5.2.3)

- Hold the base carrying handle with one hand and grasp the end of one of the longer legs with the other hand. Pull this leg away from the base forward in an arc, until the locking pin engages. The locking pin is spring loaded and automatically engages when the legs are in the correct position. Watch the leg lock knob drop down, even with the lower band on the base, indicated by an arrow.
- Repeat procedure (a) to extend other set of legs
- Set portable base on even ground with all leg spikes in contact with the ground.

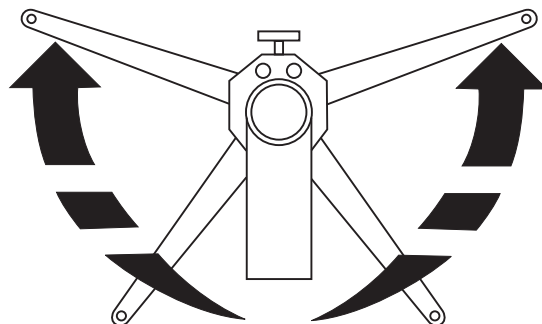

Figure 5.2.1
Hold base carrying handle and grasp end of longer leg



Figure 5.2.2
One set of legs opened and locked in position



Figure 5.2.3
Both sets of legs opened and locked in position

Lift off the storage cap and remove the anchor strap from inside the base, figure 4.2.4. Keep the anchor strap near the monitor as it will be used to anchor monitor before use.

WARNING In the unfolded position the legs provide a stable base for operation of the monitor. Lack of stability can cause an out of control monitor resulting in injury or death. Do not operate as a portable monitor with either one or both legs in the folded position.

WARNING For stable operation the spikes must maintain in contact with the ground. Do not place the monitor on top of debris, objects, or uneven terrain that would keep any of the spikes from contacting the ground.

5.3 RETRACTING PORTABLE BASE LEGS

For carrying and storage, the legs are retracted as follows:

- Pull up on one of the spring loaded leg lock knobs, grasp the forward leg, on the same side, and push it, in an arc, towards the rear of the unit. The leg lock knob may be released as soon as the front leg begins to move out of position. Continue to push until both legs come in contact with the rear stop.
- Repeat procedure (a) to retract the other legs.

5.4 PORTABLE BASE LEG SPIKES

The STOW-A-WAY 800 Portable Monitor has (5 or 6) tungsten carbide tipped spikes on the legs and the base to resist sliding by digging into the surface the monitor is sitting on. The amount of sliding force these spikes can withstand depends upon the amount of downward and sideways force that is on the base and the hardness and texture of the surface the spikes are in contact with. At low elevation angles, it is difficult for these spikes to resist sliding. These spikes are essential to safe operation of the monitor and must be in contact with the ground at all times. Set the monitor on an even surface so that all three spikes contact the ground. Replace any spike if the tip diameter exceeds 1/16 inch (1.6 mm).



Spikes must be sharp to provide resistance to sliding. Replace any spike if the tip diameter exceeds 1/16 inch (1.6 mm).



Spikes are sharp and exposed. Use care around spikes to avoid injury and damage to clothing or other property.

5.5 PORTABLE BASE ANCHORING

The safest method of restraining the monitor is to use a tie down strap. It is inherently more reliable than other methods since it does not rely on traction or digging in of the spikes. It is also the safest method because, even if the monitor moves, its travel is limited by the strap. A forward attachment point and a strap are provided with the Crossfire. A loop on the end of the strap may be placed over the anchor point or the strap may be wrapped around an object, such as a tree, and the snap end of the strap passed through the loop and pulled tight. Keep the entire length of the strap as close to the ground as possible. Snap the hook into the hole in the front of the Crossfire. If the strap is too short to reach a suitable anchor, it may be extended with strong rope or chain. Keep the distance between the Crossfire and anchor as short as possible. Remove all slack between the Crossfire and anchor before flowing water.

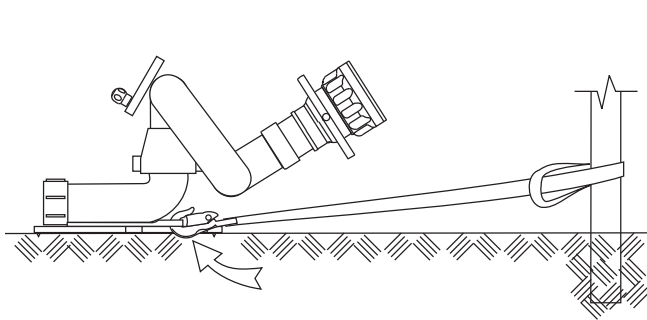

A sliding monitor can cause injury. Remove all slack between the anchor and base before flowing water.

At low nozzle elevation angles the base may also require additional anchoring. The ability of a single anchor to stop sliding is a function of the horizontal angle between the strap and water stream. When the stream is in line with the anchor any sliding will be arrested by the anchor. As the horizontal angle increases between the anchor strap and the stream, the base can begin to slide in an arc around the anchor point. In this situation multiple anchor points may be required.

The strap should be stored inside the monitor base when not in use. The black rubber cap on the strap will hold the strap in the base and protect the sealing surface of the quick connect swivel joint.

5.6 ADDING A FLOW SAFETY VALVE

The STOW-A-WAY 800 portable base does not contain a flow safety valve.

A flow safety valve upgrade kit #XF500-KIT may be added to this portable base at any time to gain the features of the flow safety valve. The kit may be installed in the field or at the factory.

The flow safety valve reduces the flow area through the monitor by 90%, should the base lose contact with the ground for any reason. In the reduced flow condition, the nozzle reaction is less thereby reducing the risk of injury.

5.7 HOSE CONNECTION

Make the hose connection(s) to the portable base and extend the hose(s) straight back from the portable base at least 10 feet (3 meters). If only one inlet of a double inlet base is used, a clapper valve will automatically close off the other inlet. Use caution when turning on the water to the monitor on the portable base. As the hose fills it will become stiff and may cause the monitor and portable base to slide or tip or both. Open the pumper valve to the monitor slowly.

5.9 PRESSURE RELIEF OPTION

The optional pressure relief valve on the single inlet portable base can be adjusted to open between 90 and 300 psi. The pressure relief valve, TFT part A1820, is set at the factory to open at 150 psi. To change the relief pressure refer to the label on the bottom side of the pressure relief valve. A pressure relief valve can be added to the single inlet portable base by removing the cover on the side of the base. For additional information call 800-348-2686.

5.10 PRESSURE RELIEF VALVE SETTING

To set the relief valve pressure turn the adjusting screw on the relief valve housing until the surface of the screw is even with the desired pressure. Do not cap or plug discharge opening.

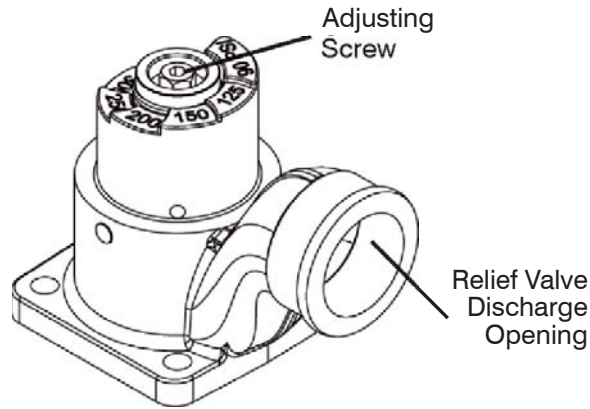

6.0 PORTABLE BASE STORAGE

The portable base may be stored in a compartment, on the optional storage bracket, TFT part number XF-B. This bracket is NOT designed to withstand the reaction forces of an operating monitor stream. It is to be used for storage and transportation only. The storage bracket may be mounted on a horizontal surface, horizontally or vertically on a vertical surface, or on the underside of a horizontal surface such as the top of a compartment. A strap helps hold the base on the bracket. Mounting instructions are supplied with the bracket.

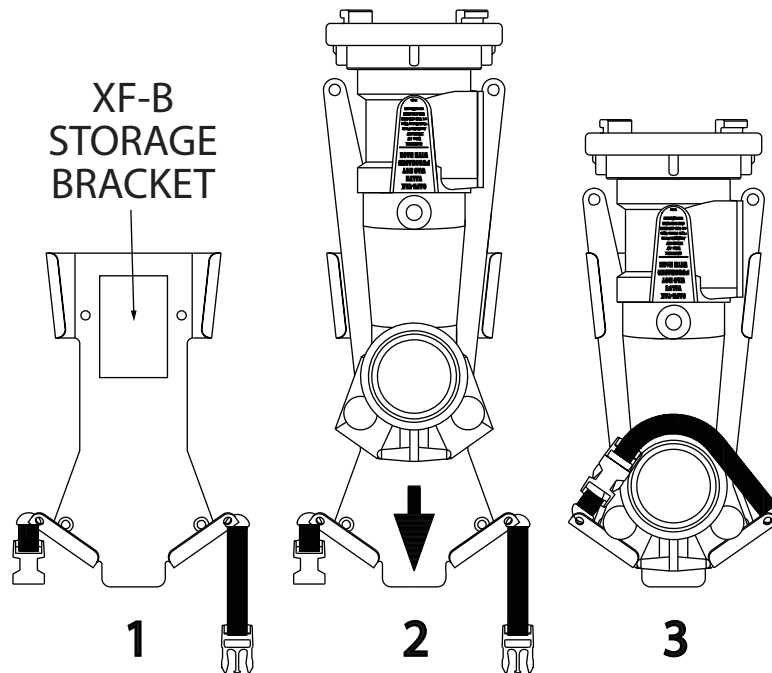

6.1 STORAGE BRACKET

Tools Required:

- Electric Drill
- Drill Bits see instructions for correct size
- #3 Phillips Screw Driver
- 7/16 or adjustable wrench
- 5/32 allen wrench

The CROSSFIRE Portable Monitor Storage Bracket comes with 1/4-20 Stainless Steel Self tapping screws, nuts and washers. If the material beneath the Storage Bracket is thick and substantial enough, the self-tapping screws may be screwed directly into the mounting surface. If the backside of the mounting surface is accessible, clearance holes may be drilled, and the nuts and washers may be used on the backside. It is the responsibility of the installer to determine if the mounting surface is satisfactory.

The CROSSFIRE Portable Monitor storage bracket must be securely mounted to a surface capable of supporting the weight of the Monitor including any shock loads that may result from rough roads. The storage bracket may be mounted on a vertical surface or a horizontal surface with the nozzle end pointing down or sideways. It is the responsibility of the installer to determine if the installation is capable of these loads.



Do not use the Monitor Storage Bracket as a mount when flowing water. Nozzle reaction will cause monitor instability. The Monitor Storage Bracket is designed to store the Portable Monitor.

6.1.1 INSTALLATION INSTRUCTIONS FOR BLIND MOUNTING

Lay the bracket in the area where the monitor will be mounted. Make sure the nozzle will be pointing down or sideways. Make sure there is enough clearance to get the monitor in and out of the bracket and that it does not interfere with other equipment on the truck.

Make sure the material beneath the bracket is substantial and thick enough to hold self-tapping screws as well as the weight of the monitor. Make sure the area on the other side of the mounting surface is clear; you don't want to run a drill into a bundle of wires. We recommend a minimum thickness of 3/32" (.093" - 2.4 mm) in aluminum and 5/64 (.078" 2mm) in steel. Using the bracket as a pattern, drill through one hole into the mounting surface and install one screw. (Put washers on the screws before installing). See the chart in the mounting bracket dimensions section to determine the correct hole size. While the first screw holds the bracket from moving, drill the remaining holes and screw in the remaining screws.

6.1.2 INSTALLATION INSTRUCTIONS WHERE BACK OF MOUNTING SURFACE IS ACCESSIBLE

Lay the bracket in the area where the monitor will be mounted. Make sure the nozzle will be pointing down or sideways. Make sure there is enough clearance to get the monitor in and out of the bracket and that it does not interfere with other equipment on the truck.

Make sure the material beneath the bracket is substantial enough to hold the weight of the monitor. Make sure the area on the other side of the mounting surface is clear; you don't want to run a drill into a bundle of wires. Using the bracket as a pattern, drill one 1/4" (.250" - 6.4 mm) diameter hole through the bracket. Bolt the bracket to the mounting surface from the backside. (Put the washers on the side with the nuts). While the first screw holds the bracket from moving, drill the remaining holes and screw in the remaining screws. Secure with washers and nuts.

HOLE SIZE CHART FOR SELF TAPPING SCREWS

ALUMINUM				STEEL			
Material Thickness	Inches	mm	Use Drill	Material Thickness	Inches	mm	Use Drill
5/16-3/32	.206	5.2	#5	3/32	.213	5.4	#3
1/8	.213	5.4	#3	1/8	.221	5.6	#2
3/16	.221	5.6	#2	3/16	.228	5.8	#1

7.0 APPROVALS

Many monitor configurations carry the FM Approval rating, NFPA certification, or EN certification.

8.0 DRAWINGS & PARTS LIST

8.1 MONITOR DRAWING AND PART LIST

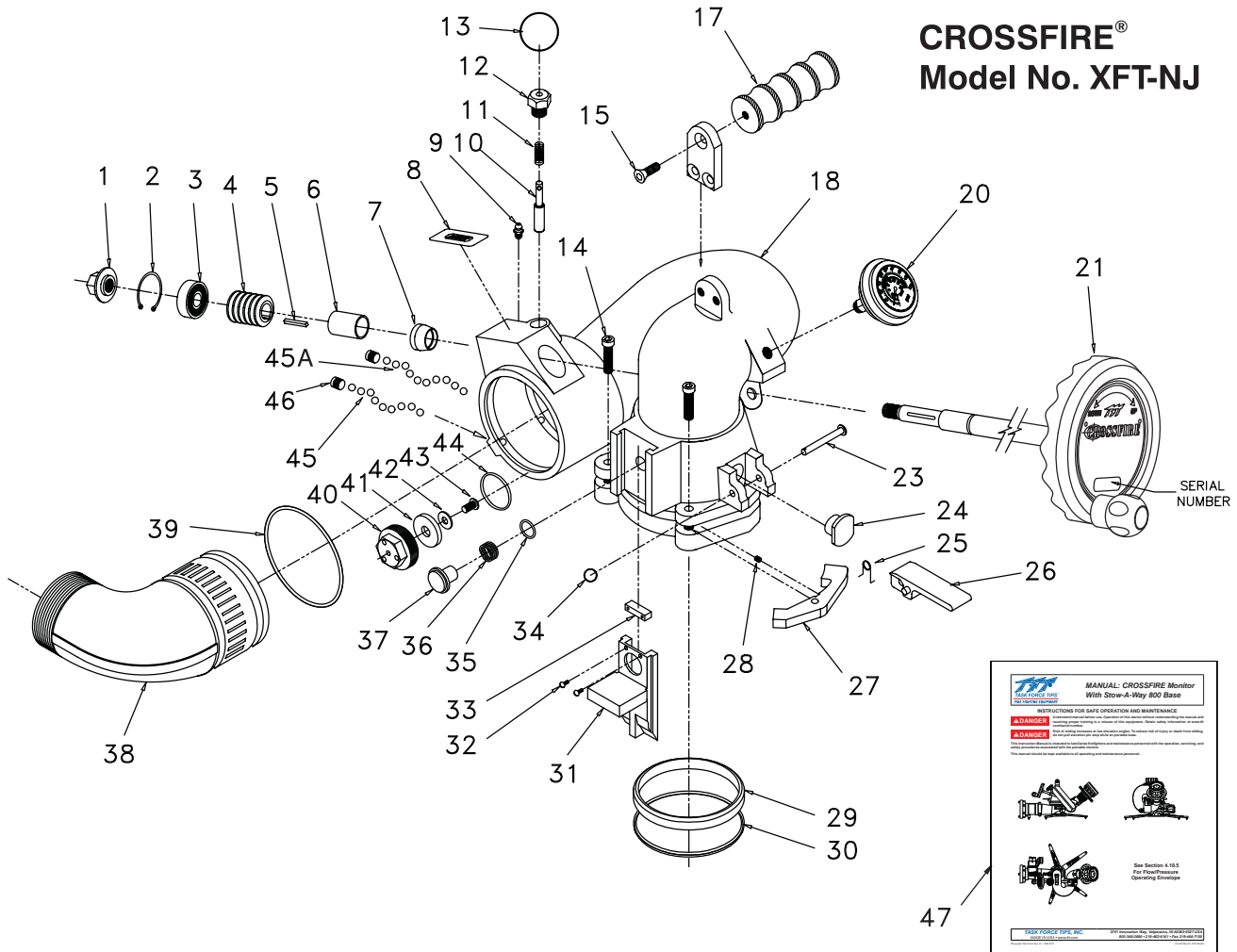

INDEX	DESCRIPTION	QTY	ITEM #
1	SHAFT NUT	1	X210
2	SNAP RING	1	VR4220
3	BEARING	1	VM4250
4	WORM WITH KEYWAY	1	X220
5	KEY 1/8 X 1.00	1	X225
6	BUSHING	1	X230
7	BOOT	1	X240
8	DANGER LABEL	1	XL090
9	11/4-28 GREASE FITTING	1	VT25-28ZERK
10	PULL PIN	1	X340
11	PULL PIN SPRING	1	X345
12	PULL PIN HOUSING	1	X350
13	KEY RING	1	X342
14	5/16-18 X 1-1/4 SHCS	2	VT31-18SH1.2
15	3/8-16X7/8SHCS	1	VT37-16SH875
17	PEG - CARRYING HANDLE	1	X362
18	BIG BEND/BELL ASSEMBLY	1	X800
20	200 PSI/BAR GAGE/BUMPER	1	X823
21	HANDWHEEL ASSEMBLY	1	X810
23	ROTATION LOCK PIVOT	1	X180
24	ROTATION LOCK INSERT	1	X170
25	ROTATION LOCK SPRING	1	X152
26	ROTATION LOCK LEVER	1	X821

INDEX	DESCRIPTION	QTY	ITEM #
27	PAWL	2	X135
28	DETENT SPRING	2	H770
29	WEAR STRIP	1	X120
30	CUP SEAL .366 NITRILE 70A	1	X125
31	SLIDE BAR	1	X140
32	#6-32 X 1/4 BUTTON HEAD	2	VT06E32BH250
33	COVER	1	X142
34	CLEVIS PIN RETAINER	1	X137
35	O-RING-018	1	VO-016
36	PLUNGER WAVE SPRING	1	X165
37	SAFETY PLUNGER	1	X150
38	2.5 NH ELBOW	1	X339NJ**
39	O-RING-241	1	VO-241
40	DRAIN HOUSING	1	X375
41	DRAIN VALVE	1	X382
42	FLAT WASHER	1	VW687X281-50
43	1/4-28 X 1/2 BHCS	1	VT25-28BH500
44	O-RING 130	1	VO-130
45	5/16 SS BALLS	38	VB.312
45A	5/16 TORLON BALLS	38	VB.312TO
46	3/8-24 x 3/8 SOCKET SET	2	VT37F24SS312
47	MANUAL CROSSFIRE	1	LIX-040

8.2 STOW-A-WAY 800 DRAWING AND PART LIST

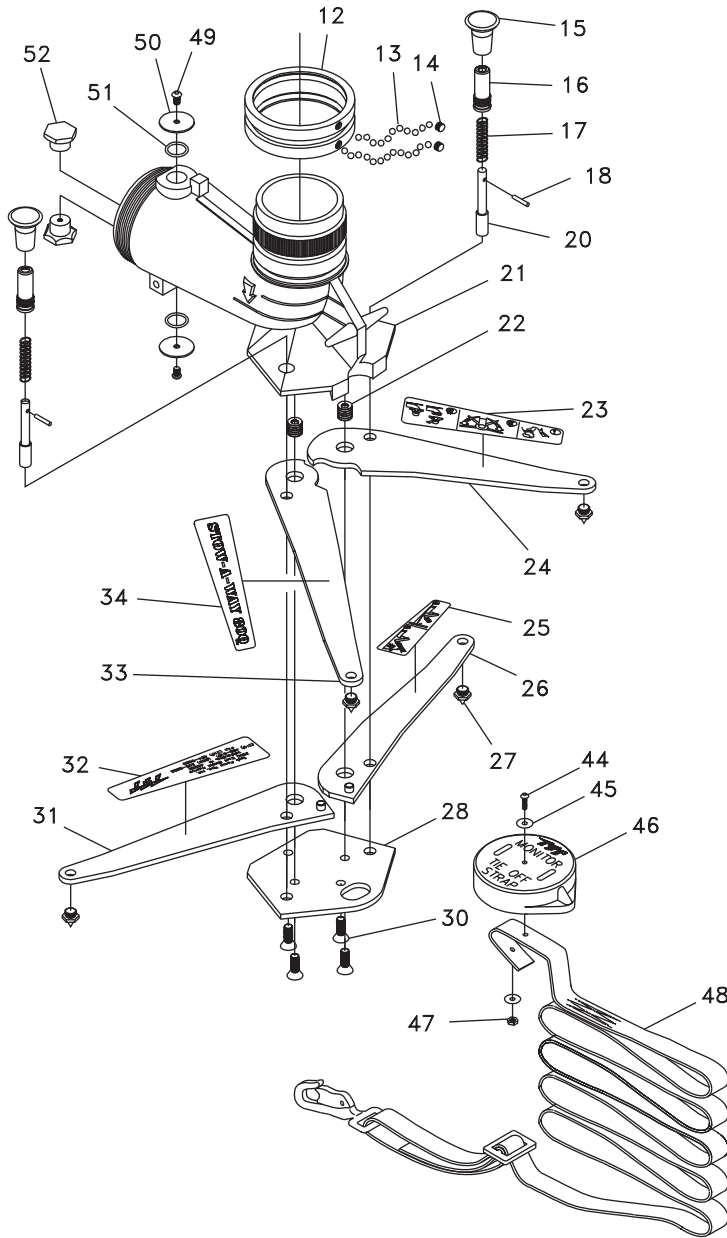

STOW-A-WAY 800®

without Safety Valve

INDEX	DESCRIPTION	QTY	ITEM #
12	SWIVEL RING	1	X425
13	5/16 SS BALLS	76	VB.312
14	SWIVEL SCREW	2	X405
15	SHOT PIN KNOB	2	X430
16	KNOB BARREL	2	X440
17	SHOT PIN SPRING	2	X445
18	5/32 x 7/8 SPIROL PIN	2	V1900
20	SHOT PIN	2	X435
21	BASE	1	X420
22	BELLEVILLE WASHER	12	D07590
23	INSTRUCTION LEG LABEL 1-3	1	XL010
24	FRONT LEG - LEFT	1	X470L
25	INSTRUCTION LEG LABEL 4-5	1	XL020
26	REAR LEG - LEFT	1	X460L
27	SPIKE	4	X480
28	BOTTOM PLATE	1	X450
30	3/8-16 X 3/4 FLAT HEAD SHCS	4	VT37-16FH750
31	REAR LEG - RIGHT	1	X460R
32	TFT LEG LABEL	1	XL050
33	FRONT LEG - RIGHT	1	X470R
34	SAFE-TAK LEG LABEL	1	XL040
44	#10-32 x 3/4 BUTTON HEAD	1	VT10E32BH750
45	STAINLESS STEEL WASHER 18-8	2	V2038
46	STRAP CAP	1	X457
47	#10-32 HEX NUT	1	VT10-32NT
48	STRAP ASSEMBLY	1	RX455
49	1/4-28 X 1/2 BUTTONHEAD	2	VT25-28BH500
50	2.5" CLAPPER WASHER	2	X752
51	O-RING-118	2	VO-118
52	PLUG	2	X510

8.3 VALVE UPGRADE KIT (XF500-KIT) DRAWING AND PART LIST

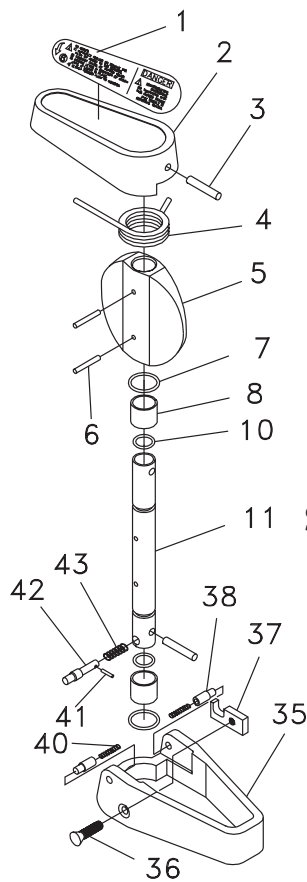

See
Section
5.6

XF500-KIT VALVE UPGRADE KIT

INDEX	DESCRIPTION	QTY	ITEM #
1	SAFETY VALVE HANDLE LABEL	1	XL070
2	VALVE HANDLE	1	X540
3	1/4 x 1 3/8 SPIROL PIN	1	VP250X1.375H
4	TORSION SPRING	1	X560
5	BUTTERFLY	1	X550
6	5/32 x 1 1/8 SPIROL PIN	3	V1920
7	O-RING-118	2	VO-118
8	BUSHING	2	X565
10	O-RING-113	2	VO-113
11	VALVE SHAFT	1	X570
35	PADDLE	1	X530
36	1/4-20 x 7/8 FLAT HEAD	1	VT25E20FH875
37	WEAR PLATE	1	X585
38	PADDLE PIVOT	2	X590
40	PADDLE PIVOT SPRING	2	X575
41	3/32 x 1/2 SPIROL PIN	1	VP094X500H
42	TRIP PIN	1	X580
43	TRIP PIN SPRING	1	X582

8.4 HIGH FLOW INLET OPTION

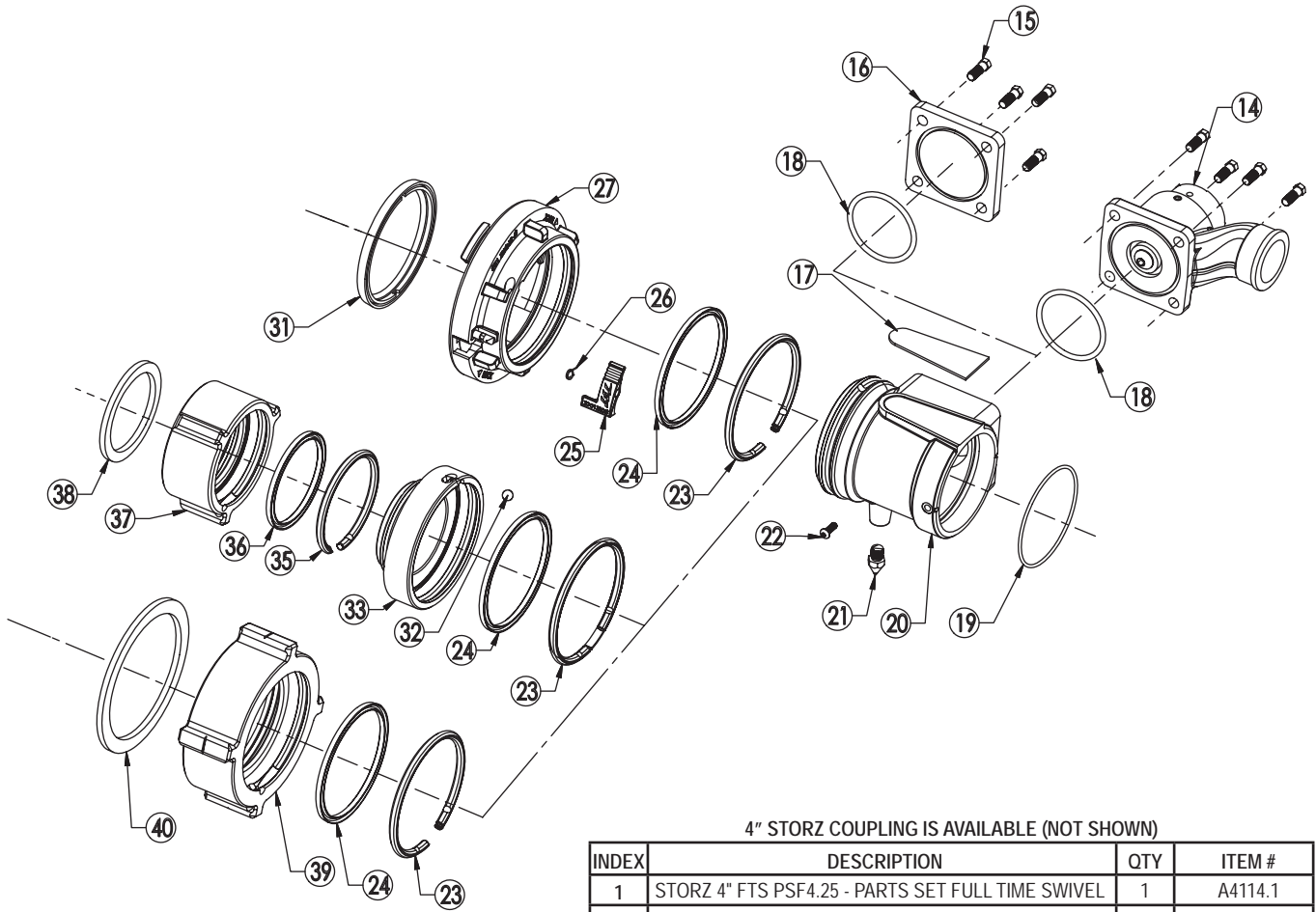

4" STORZ COUPLING IS AVAILABLE (NOT SHOWN)

INDEX	DESCRIPTION	QTY	ITEM #
1	STORZ 4" FTS PSF4.25 - PARTS SET FULL TIME SWIVEL	1	A4114.1
2	MATE PSM4.25 X PSF5.25 LOCKOUT PART SET	1	A4730.2

INDEX	DESCRIPTION	QTY	ITEM #
14	RELIEF VALVE WITHOUT THREAD, ALUMINUM	1	A1810
15	7/16-14 X 1 HEX HEAD BOLT 18-8 STAINLESS STEEL	4	VT43-14HX1.0
16	LDH BLANK CAP HARDCOAT USE ON X651	1	X631
17	SAFETY VALVE BASE LABEL	1	XL080
18	O-RING-236 3-1/4 ID 1/8 C/S 3.234 +/- .024 ID .139 +/- .004 C/S	1	VO-236
19	O-RING-244 4-1/4 ID 1/8 C/S 4.234 +/- .030 ID .139 +/- .004 C/S	1	VO-244
20	LDH ADAPTOR W/PSM5.25	1	X651
21	REAR SPIKE	1	X482
22	1/4-28 X 3/4 BUTTON HEAD - ND PATCH	1	VT25Y28BH750
23	PLASTIC STRIP 5.25" - MOLDED	1	A1291
24	CUP SEAL 5.25 X 4.75 X 1/4 PRECISION ASSOCIATES #666-427	1	A1296
25	LOCKING LEVER - MOLDED	1	A4176
26	SPRING TORSION (STORZ LOCK) 9991067 MIDSTATE # 210049	1	A4230
27	COUPLING HEAD STROZ 5 X 5.25 PSF HARDCOAT	1	A4135
31	GASKET 5" PRESSURE MOLDED 9991000	1	A4220
32	BALL 7/16 STAINLESS 302 GRADE 100	1	VB.437
33	MATE PSM4.25 X PSF5.25 - HARDCOAT	1	A4730
35	PLASTIC STRIP 4.25" - MOLDED	1	A1292
36	CUP SEAL 4.25 X 3.750 X 1/4	1	A1297
37	COUPLING RL 3.0NH X PSF4.25	1	A4650N
	COUPLING RL 3.5NH X PSF4.25	1	A4655N
38	GASKET 3.0 HOSE COUPLING	1	V3194
	GASKET 3.5 HOSE COUPLING	1	V3196
39	4.0 NH FEMALE X PSF5.25	1	A4660N
40	4.0 HOSE COUPLING GASKET	1	V3198

8.5 DOUBLE INLET OPTION

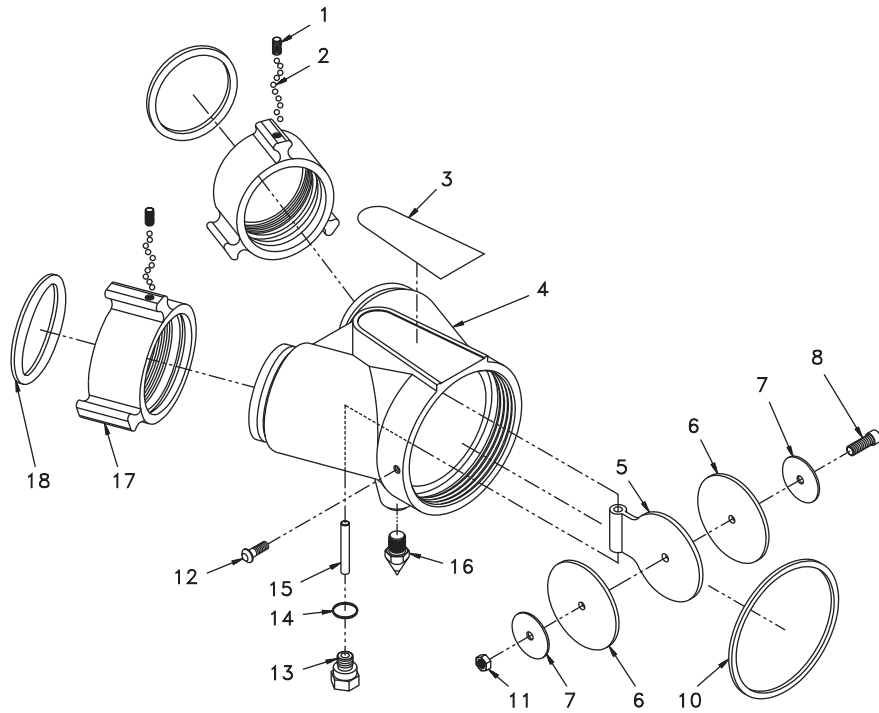

INDEX	DESCRIPTION	QTY	ITEM #
1	1/4-28 x 1/2 SOCKET SET	2	VT25-28SS500
2	3/16 SS BALL	96	V2120
3	SAFETY VALVE BASE LABEL	1	XL080
	NO VALVE BASE LABEL		XL085
4	2.5" WYE	1	X712
5	2.5" CLAPPER	1	X772
6	2.5" CLAPPER GASKET	2	X762
7	WASHER	2	VW1.9x26-076
8	1/4-20 x 1 SHCS, SS	1	VT25-20SH1.0

INDEX	DESCRIPTION	QTY	ITEM #
10	O-RING-244	1	VO-244
11	1/4-20 STAINLESS NUT	1	VT25-20NT
12	1/4-28 X 3/4 BUTTON HEAD	1	VT25-28BH750
13	PIVOT BOLT	1	X784
14	O-RING-013	1	VO-013
15	CLAPPER PIVOT	1	X732
16	REAR SPIKE	1	X482
17	2.5" NH COUPLING (pictured)	2	M307N
18	2.5" COUPLING GASKET (pictured)	2	V3190

9.0 WARRANTY

Task Force Tips, Inc., 3701 Innovation Way, Valparaiso, Indiana 46383-9327 USA ("TFT") warrants to the original purchaser of its nozzles and other equipment ("equipment"), and to anyone to whom it is transferred, that the equipment shall be free from defects in material and workmanship during the five (5) year period from the date of purchase.

TFT's obligation under this warranty is specifically limited to replacing or repairing the equipment (or its parts) which are shown by TFT's examination to be in a defective condition attributable to TFT. To qualify for this limited warranty, the claimant must return the equipment to TFT, at 3701 Innovation Way, Valparaiso, Indiana 46383-9327, within a reasonable time after discovery of the defect. TFT will examine the equipment. If TFT determines that there is a defect attributable to it, it will correct the problem within a reasonable time. If the equipment is covered by this limited warranty, TFT will assume the expenses of repair.

If any defect attributable to TFT under this limited warranty cannot be reasonably cured by repair or replacement, TFT may elect to refund the purchase price of the equipment, less reasonable depreciation, in complete discharge of its obligations under this limited warranty. If TFT makes this election, claimant shall return the equipment to TFT free and clear of any liens and encumbrances.

This is a limited warranty. The original purchaser of the equipment, any person to whom it is transferred, and any person who is an intended or unintended beneficiary of the equipment, shall not be entitled to recover from TFT any consequential or incidental damages for injury to person and/or property resulting from any defective equipment manufactured or assembled by TFT. It is agreed and understood that the price stated for the equipment is in part consideration for limiting TFT's liability. Some states do not allow the exclusion or limitation of incidental or consequential damages, so the above may not apply to you.

TFT shall have no obligation under this limited warranty if the equipment is, or has been, misused or neglected (including failure to provide reasonable maintenance) or if there have been accidents to the equipment or if it has been repaired or altered by someone else.

THIS IS A LIMITED EXPRESS WARRANTY ONLY. TFT EXPRESSLY DISCLAIMS WITH RESPECT TO THE EQUIPMENT ALL IMPLIED WARRANTIES OF MERCHANT ABILITY AND ALL IMPLIED WARRANTIES OF FITNESS FOR A PARTICULAR PURPOSE. THERE IS NO WARRANTY OF ANY NATURE MADE BY TFT BEYOND THAT STATED IN THE DOCUMENT.

This limited warranty gives you specific legal rights, and you may also have other rights which vary from state to state.

Visit TFT's web site at www.tft.com

10.0 ANSWERS TO YOUR QUESTIONS

We appreciate the opportunity of serving you and making your job easier. If you have any problems or questions, our toll-free "Hydraulics Hotline", 800-348-2686, is normally available to you 24 hours a day, 7 days a week.

11.0 MAINTENANCE

The CROSSFIRE® monitor and its base require little maintenance. The unit should be kept clean and free of dirt by flushing with water after each use. All controls should be checked for freedom of movement and condition. Any inoperable or damaged part should be repaired or replaced immediately.

Specific areas to check are as follows:

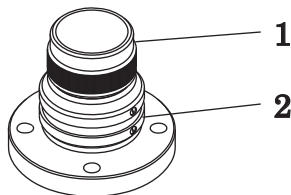

Truck Mount Base:

- 1) Sealing surface above swivel joint must be smooth.
- 2) Swivel joint must rotate freely.

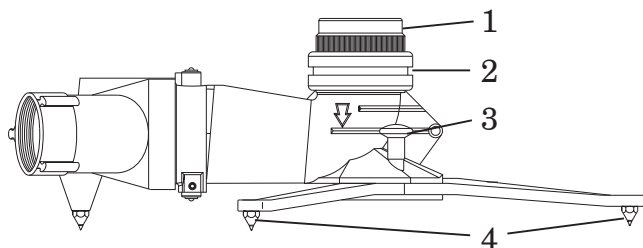

Portable Base:

- 1) Sealing surface above swivel joint must be smooth.
- 2) Swivel joint must rotate freely.
- 3) Legs and leg lock pins must move freely and lock in position.
- 4) Leg spikes must be sharp.

(replace if flats at tip of spikes exceed 1/16" diameter)

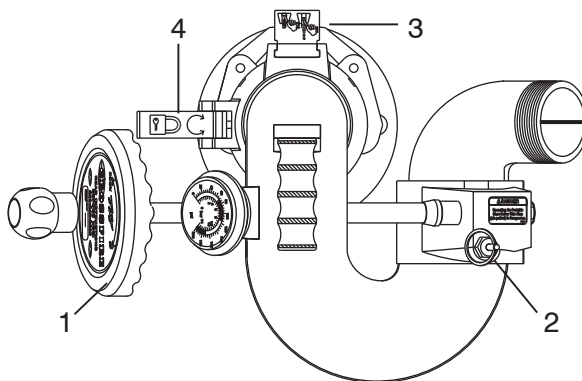

Monitor:

- 1) Handwheel must rotate freely.
- 2) Elevation stop pin must return to safe position.
- 3) Quick disconnect latch and safety catch must operate freely.
- 4) Rotation lock must operate freely and keep monitor from rotating when engaged.

CAUTION

Any alterations to the monitor and its markings could diminish safety and constitutes a misuse of this product.

Any CROSSFIRE taken out of service due to failure should be returned to the factory for repair or replacement. If you have any questions regarding the testing or maintenance of your valve, please call Task Force Tips at 800-348-2686.

11.1 GREASING THE WORM GEAR

Turn the handwheel to move the nozzle to its highest elevation and pump grease (medium viscosity automotive) into the fitting in the worm gear housing until excess appears.

11.2 SERVICE TESTING

In accordance with NFPA 1962 (2013), monitors must be tested a minimum of annually. Nozzles failing any part of this test must be removed from service, repaired and retested upon completion of the repair.

11.2.1 HYDRAULIC TEST

1. The appliance being tested shall be positioned in a protective device or cover capable of holding the appliance and tested to a minimum hydrostatic pressure of 300 psi (20.7 bar or 2070 kPa).
2. Test caps capable of withstanding the required hydrostatic pressure shall be attached to openings, and a device capable of exerting the required hydrostatic pressure shall be attached to the appliance.
3. Appliances with relief valves shall have the relief valve outlet blanked off or otherwise closed during the test.
4. All air shall be bled from the system.
5. The gauge pressure shall be increased by 50 psi (3.45 bar or 345 kPa) increments and held for 30 seconds at each pressure up to the maximum pressure for which the appliance is being tested and held for 1 minute without leakage.

11.2.2 RELIEF VALVE TEST

1. Hydrostatic testing of the appliance shall be conducted prior to testing the relief valve.
2. The relief valve shall be tested separately from any device it is connected to.
3. The relief valve shall be set to its lowest setting and pressurized.
4. If the relief valve does not operate at or below a pressure 10 percent over the setting, the test shall be discontinued and the relief valve repaired or replaced.
5. A calibrated test gauge shall be used to verify the setting.
6. After successful completion of the relief valve test, the relief valve shall be reset to the pressure designated by the authority having jurisdiction.
7. The final setting of the relief valve shall be confirmed by pressure testing.

11.2.3 SHUTOFF VALVE TEST

1. If the appliance has a shutoff valve, the intake side of the shutoff valve shall be hydrostatically pressurized to the maximum working pressure of the appliance with the valve in the shutoff position.
2. There shall be no leakage through the valve.
3. A water flow through the fire hose appliance at 100 psi (6.9 bar or 690 kPa) shall be established.
4. The valve shall be closed and reopened twice and shall operate smoothly without evidence of binding or other problems.

11.2.4 RECORDS

A record of testing and repairs must be maintained from the time the nozzle is purchased until it is discarded. Each TFT moniotr is engraved with a unique serial number which, if so desired, can be used to identify nozzle for documentation purposes.

The following information, if applicable, must be included on the test record for each nozzle:

1. Assigned identification number
2. Manufacturer
3. Product or model designation
4. Vendor
5. Warranty
6. Hose connection size
7. Maximum operating pressure
8. Flow rate or range
9. Date received and date put in service
10. Date of each service test and service test results
11. Damage and repairs, including who made the repairs and the cost of repair parts
12. Reason removed from service

NFPA 1962: Standard for the care, use, inspection, service testing, and replacement of fire hose, couplings, nozzles and fire hose appliances. (2013 ed., Section 6.4.4). Quincy, MA: National Fire Protection Agency.

11.3 REPAIR

Factory service is available with repair time seldom exceeding one day in our facility. Factory serviced appliances are repaired by experienced technicians to original specifications, fully tested and promptly returned.

Repair parts and service procedures are available for those wishing to perform their own repairs. Task Force Tips assumes no liability for damage to equipment or injury to personnel that is a result of user service.

For additional information on care, maintenance and testing, refer to: NFPA 1962: Standard for the Care, Use, Inspection, Service Testing, and Replacement of Fire Hose, Couplings, Nozzles, and Fire Hose Appliances, 2013 Editio

12.0 OPERATION and INSPECTION CHECKLIST

BEFORE BEING PLACED BACK IN SERVICE, appliances must be inspected to this list:

1. All valves open and close smoothly and fully.
2. The waterway is clear of obstructions.
3. There is no damage to any thread or other type connection.
4. The pressure setting of the relief valve, if any, is set correctly.
5. All locks and hold-down devices work properly.
6. Internal gaskets are in accordance with NFPA 1962 (2013) Section 7.2.
7. There is no damage to the appliance (e.g., dents, cracks, corrosion, or other defects that could impair operation).
8. All swiveling connections rotate freely.
9. There are no missing parts or components.
10. The marking for maximum operating pressure is visible.
11. There are no missing, broken, or worn lugs on couplings.

NFPA 1962: Standard for the care, use, inspection, service testing, and replacement of fire hose, couplings, nozzles and fire hose appliances. (2013 ed., Section 6.2.1). Quincy, MA: National Fire Protection Agency.

BEFORE EACH USE the appliance must be inspected to this checklist;

- 1 • There is no damage to the appliance that could impair safe operation (e.g. dents, cracks, corrosion, missing, broken or loose parts, damaged markings, or other defects)
 - Waterway is clear of obstructions
 - Gaskets are in good repair
 - Hose and nozzle are securely attached.
 - All valves open and close fully and smoothly (if so equipped)
 - The pressure setting on the relief valve (if so equipped) is set correctly

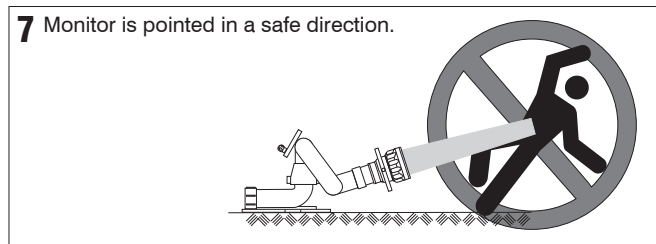
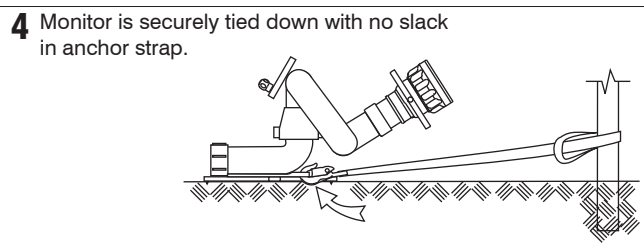
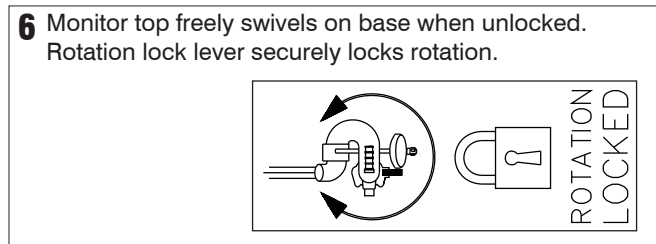
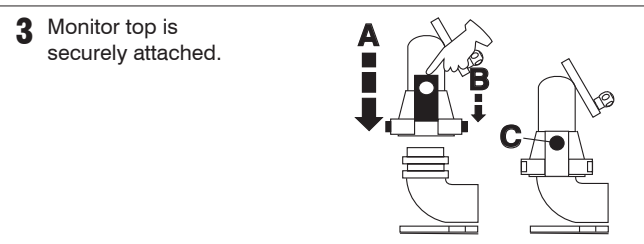
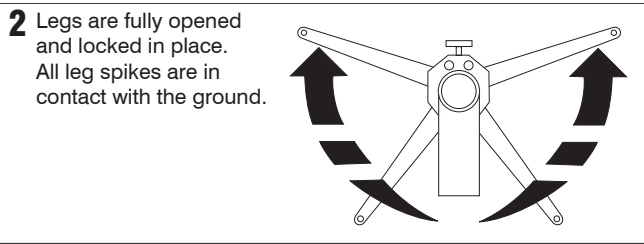

WARNING

Any monitor failing any part of the inspection checklist is unsafe and must have the problem corrected before use. Operating a monitor that fails any of the above inspections is a misuse of this equipment.

TASK FORCE TIPS, INC.
MADE IN USA • www.tft.com

3701 Innovation Way, Valparaiso, IN 46383-9327 USA
800-348-2686 • 219-462-6161 • Fax 219-464-7155