



# MANUAL: EDUCTOR 350 SERIES IN-LINE

## MANUAL FOR SAFE OPERATION AND MAINTENANCE

### ⚠ WARNING

Read instruction manual before use. Operation of this device without understanding the manual and receiving proper training is a misuse of this equipment. Users who have not read and understood all operating and safety instructions are not qualified to operate this eductor. This instruction manual is intended to familiarize firefighters and maintenance personnel with the operation, servicing, and safety procedure associated with the eductor. This manual should be kept available to all operating and maintenance personnel.

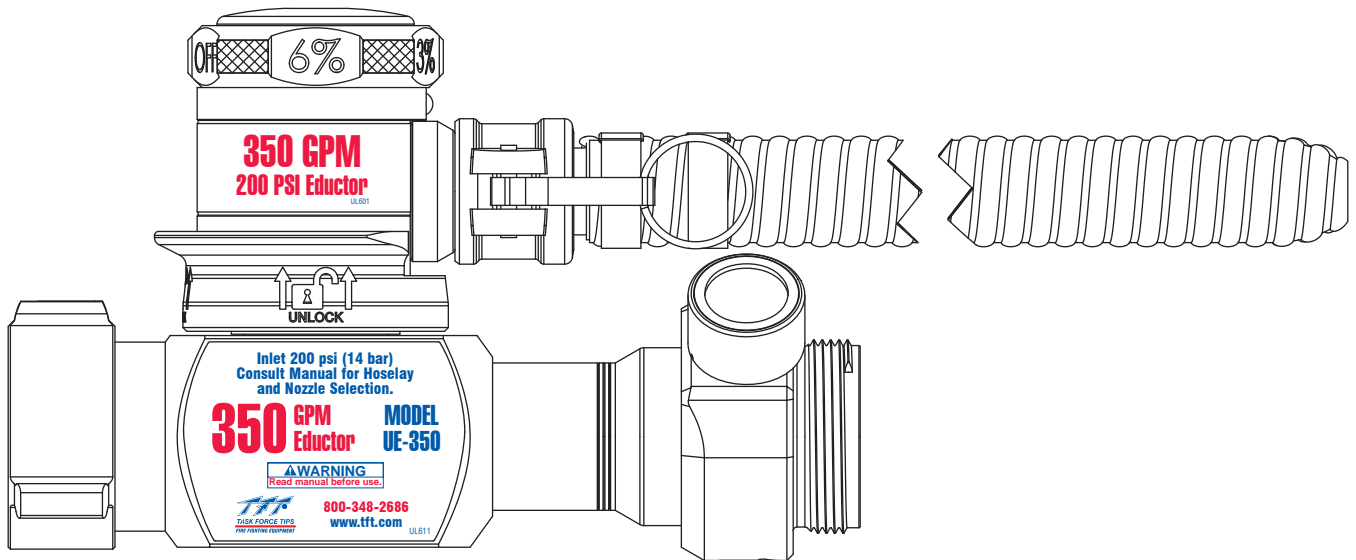

### MECHANICAL SPECIFICATIONS

	US	METRIC
Weight	13 lbs	5.9 kg
Length	13.5 in	34.3 cm
Nominal Inlet Pressure	200 psi	13.8 bar
	150 psi	10 bar
Maximum Back Pressure	130 psi	8.9 bar
	80 psi	5.5 bar
Maximum Static Pressure	900 psi	62 bar
Eductor Operating Temp Range	-45 to 135°F	-42 to 57°C
Gage Operating Temp Range	20 to 180°F	-7 to 82°C

### Models:

350 GPM (1325 LPM) 200 PSI  
 250 GPM (945 LPM) 200 PSI  
 350 GPM (1325 LPM) 150 PSI  
 250 GPM (945 LPM) 150 PSI  
 800 LPM 10 BAR  
 1000 LPM 10 BAR  
 1500 LPM 10 BAR

### Concentration Settings:

Off, 1/2%, 1%, 3%, 6%

**TASK FORCE TIPS, INC.**  
 MADE IN USA • www.tft.com

3701 Innovation Way, Valparaiso, IN 46383-9327 USA  
 800-348-2686 • 219-462-6161 • Fax 219-464-7155

## Table Of Contents

- 1.0 MEANING OF SIGNAL WORDS
- 2.0 SAFETY
- 3.0 GENERAL INFORMATION
  - 3.1 PART IDENTIFICATION
  - 3.2 INSTALLATION INSTRUCTIONS
  - 3.3 GENERAL OPERATING INSTRUCTIONS
  - 3.4 CLEANING INSTRUCTIONS
  - 3.5 CONCENTRATE INTAKE HOSE OPTIONS
- 4.0 FOAM SELECTION
  - 4.1 CLASS A FOAM
  - 4.2 CLASS B FOAM
  - 4.3 FOAM COMPATIBILITY
  - 4.4 FOAM CONSUMPTION
- 5.0 MAXIMUM HOSE LAY
- 6.0 NOZZLE SELECTION
- 7.0 TROUBLE SHOOTING
- 8.0 DRAWING AND PARTS LIST
- 9.0 FOAM BUCKET ARRANGEMENT
  - 9.1 FOAM SUPPLY LOGISTICS
- 10.0 MAINTENANCE
- 11.0 WARRANTY



### PERSONAL RESPONSIBILITY CODE

The member companies of FEMSA that provide emergency response equipment and services want responders to know and understand the following:





1. Firefighting and Emergency Response are inherently dangerous activities requiring proper training in their hazards and the use of extreme caution at all times.
2. It is your responsibility to read and understand any user's instructions, including purpose and limitations, provided with any piece of equipment you may be called upon to use.
3. It is your responsibility to know that you have been properly trained in Firefighting and /or Emergency Response and in the use, precautions, and care of any equipment you may be called upon to use.
4. It is your responsibility to be in proper physical condition and to maintain the personal skill level required to operate any equipment you may be called upon to use.
5. It is your responsibility to know that your equipment is in operable condition and has been maintained in accordance with the manufacturer's instructions.
6. Failure to follow these guidelines may result in death, burns or other severe injury.



Fire and Emergency Manufacturers and Service Association  
P.O. Box 147, Lynnfield, MA 01940 • [www.FEMSA.org](http://www.FEMSA.org)

## 1.0 MEANING OF SAFETY SIGNAL WORDS

A safety related message is identified by a safety alert symbol and a signal word to indicate the level of risk involved with a particular hazard. Per ANSI standard Z535.6-2011, the definitions of the four signal words are as follows:

	<b>DANGER</b> indicates a hazardous situation which, if not avoided, will result in death or serious injury.
	<b>WARNING</b> indicates a hazardous situation which, if not avoided, could result in death or serious injury.
	<b>CAUTION</b> indicates a potentially hazardous situation which, if not avoided, could result in minor or moderate injury.
	<b>NOTICE</b> is used to address practices not related to physical injury.

## 2.0 SAFETY

The eductor is designed for Class A and Class B foam concentrates. If you intend to use the eductor for liquids other than Class A and Class B concentrates and water, we urge you to contact the Task Force Tips Engineering Department. The use of other liquids may void the warranty and subject the user to hazards not addressed in this manual. The user assumes all risks for non-intended uses.

- Make sure there is enough foam concentrate prepared before fighting fire. TFT's eductors are calibrated 15% more than the nominal rate, or half percent point, whichever is less. Per FOAM EQUIPMENT AND LIQUID CONCENTRATES – UL 162, the liquid concentrate induction rate of a proportioner, expressed as a percentage of the flow rate of the mixed water plus concentrate solution, shall be minus zero (0) percent, plus thirty (30) percent of the manufacturer's specified induction rate or one percent point, whichever is less.
- Make sure the meter head set to OFF position and the correct nozzle and hose lay are securely attached to the eductor before the hose line is charged.
- Make sure the nozzle gallonage matches eductor's gallonage.
- Make sure the hose lay does not exceed the maximum listed in the operating instruction.
- Make sure that the meter head is set to the correct concentration for the type of foam being used. Foam concentrates can be ineffective if not used at the correct percentage.

 **DANGER** Lack of foam can place operator at risk of injury or death. Establish foam flow before advancing into hazardous situations. Make sure you do not run out of foam concentrate before the task is complete. Check concentrate level periodically and keep an adequate supply on hand.

 **WARNING** Do not use Class A foam on Class B fires or Class B foam on Class A fires. Note: Some foam concentrates are universal and can be used on Class B fires and spills and as a wetting agent on Class A fires. (Refer to foam concentrate manufacturer's recommendations for proper foam choice.)

 **WARNING** Improper use of foam can result in injury or damage to the environment. Follow the foam concentrate manufacturer's instructions and fire service training to avoid the following:

- Using the wrong type of foam on a fire, i.e. Class A foam on Class B flammable liquid fire
- Mishandling of concentrates
- Plunging foam into pools of liquid fuels
- Directing foam onto yourself or other personnel

 **WARNING** There is a wide variety of foam concentrates. Each user is responsible for verifying that any foam concentrate chosen to be used with this unit has been tested to assure that the foam obtained is suitable for the purpose intended.

 **WARNING** The eductor may be damaged if frozen while containing significant amounts of water or foam. Such damage may be difficult to detect visually, and can lead to possible injury or death. Any time the eductor is subject to possible damage due to freezing, it must be hydrostatically tested by qualified personnel before being considered safe for use.

### 3.0 GENERAL INFORMATION

UE-250-NJ	INLINE EDUCTOR 250 GPM 2.5"NH 200 PSI	UE-800-BJ	INLINE EDUCTOR 800 LPM 2.5"BSP 10 BAR
UE-350-NJ	INLINE EDUCTOR 350 GPM 2.5"NH 200 PSI	UE-800-BP	INLINE EDUCTOR 800 LPM 4.0"BSP 10 BAR
UE-250L-NJ	INLINE EDUCTOR 250 GPM 2.5"NH 150 PSI	UE-800-BICJ	INLINE EDUCTOR 800 LPM 2.5"BIC 10 BAR
UE-350L-NJ	INLINE EDUCTOR 350 GPM 2.5"NH 150 PSI	UE-800-75MM	INLINE EDUCTOR 800 LPM 75MM 10 BAR
		UE-1000-BJ	INLINE EDUCTOR 1000 LPM 2.5"BSP 10 BAR
		UE-1000-BP	INLINE EDUCTOR 1000 LPM 4.0"BSP 10 BAR
		UE-1000-BICJ	INLINE EDUCTOR 1000 LPM 2.5"BIC 10 BAR
		UE-1000-75MM	INLINE EDUCTOR 1000 LPM 75MM 10 BAR
		UE-1500-BJ	INLINE EDUCTOR 1500 LPM 2.5"BSP 10 BAR
		UE-1500-BP	INLINE EDUCTOR 1500 LPM 4.0"BSP 10 BAR
		UE-1500-BICJ	INLINE EDUCTOR 1500 LPM 2.5"BIC 10 BAR
		UE-1500-75MM	INLINE EDUCTOR 1500 LPM 75MM 10 BAR

The eductor proportioning rate ranges from 1/2% to 6%.

TFT's 350 Series eductors can be used with 1/2% Class A foam concentrate for wildland, rural, and urban fire suppression on Class A fuels (wood, paper, combustible materials). On Class A materials, the eductors are intended to be used for direct extinguishment, overhaul, and wetting of fuels. Some foam concentrates are corrosive; we recommend using only Class A concentrates that have received USDA and USFS approval.

On class B materials, the eductors are primarily intended for vapor suppression or extinguishment. They can be used with high viscosity 1%, 3%, 6%, 3x3%, and 3x6% Alcohol Resistant Class B concentrates on flammable liquids containing polar solvents.

The eductor can also be used with plain AFFF concentrates rated at 1%, 3% or 6% with various freeze protected foams, and with FFFP foam types. These foams generally have a lower viscosity than the calibration viscosity of the TFT eductor and will be inducted faster than expected resulting in stronger concentrations. While this does not degrade foam quality, it does reduce the operation time for a given foam supply. Testing should be done with the foam being used to assure accurate induction rate.

Standard inlet operating pressure is 200 psi on all TFT eductors (1400kPa/14 bar), except the low pressure versions marked for 150 psi (1000kPa/10 bar).

### 3.1 PART IDENTIFICATION

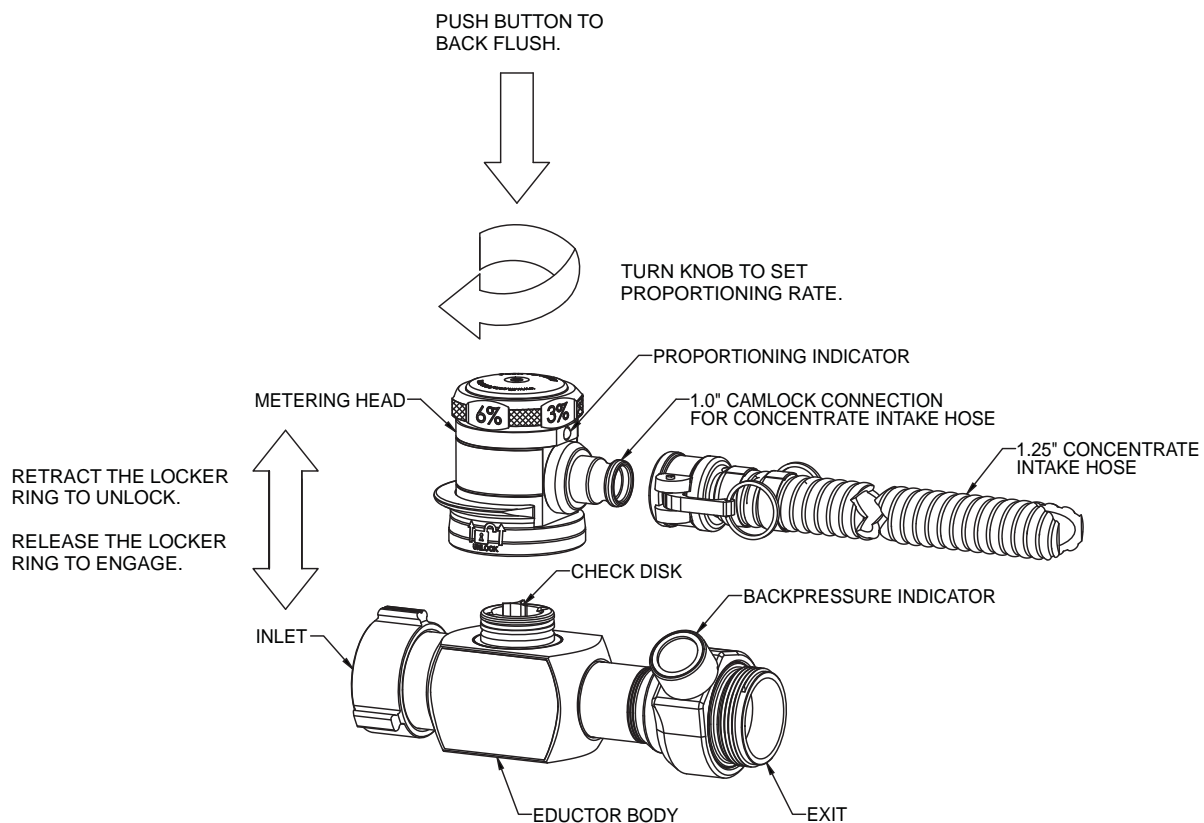

Figure 3.1

### 3.1 PART IDENTIFICATION (cont)

The eductor can be split into two parts by grasping the locking ring and retracting it fully to separate the metering head from the eductor body. All the foam passageways can easily be inspected. The foam passageway into the eductor contains a free-floating check disk with three fins. The check disk is pressure activated to keep water from coming out of the fire hose and back into the foam pail.

The metering head contains a red back flush button that can be depressed to open the check disk.

The metering head also has a large proportioning knob that can be rotated to align the ball valve to different detent positions. The 2.5" eductors have five choices: Off, ½%, 1%, 3%, and 6%. Each foam setting has a precision sized metering orifice in the valve ball. The eductor cannot be operated between settings, as the metering orifices will not line up properly. The setting of the proportioning knob lines up with the white indicator ball.

### 3.2 INSTALLATION INSTRUCTIONS

The eductor body is equipped with four 3/8-16, ¾" deep threaded mounting holes. To mount the unit, attach to the desired location using bolts with enough length to provide at least ½" engagement with the unit. Hole spacing is shown in Figure 3.2.

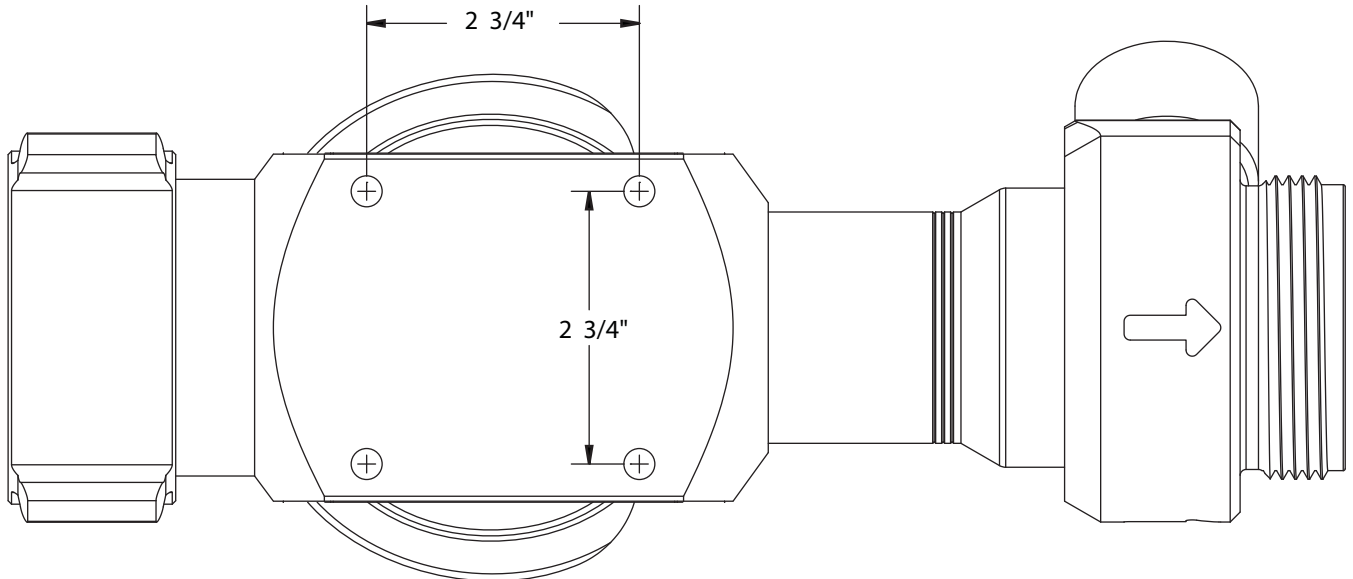

Figure 3.2

### 3.3 GENERAL OPERATING INSTRUCTIONS

- 1) Choose the appropriate foam concentration (Section 4.0)
- 2) Lay the appropriate hose line (Section 5.0)
- 3) Connect the appropriate nozzle (Section 6.0)
- 4) Charge the hose and open the nozzle fully to establish the water flow.
- 5) Adjust the pump pressure so the eductor inlet is set at pressure specified on body label.
- 6) Rotate the percentage knob to the desired concentration and put the concentrate intake hose in the foam supply.

### 3.4 CLEANING INSTRUCTIONS

After use, take the concentrate intake hose out of the foam supply and turn down the pump pressure to below 75 psi (5.2 bar). Shut off the nozzle. Restrain the hose and expect a rapid discharge of water, especially at the 6% setting. Push the red flush button and run fresh water through the hose and metering head on each setting until there is no visible foam in the flush water.

Retract the lock ring to remove the metering head. Turn off water supply and remove the eductor from the hose so that any remaining foam residue can be washed from the wand, metering head and eductor.

**CAUTION** Do not back flush above 75 psi. Rapid back flush discharge from the wand could cause injury. The back flush push button is pressure activated and must not be forced at pressures over 75 psi (5 bar).

### 3.5 CONCENTRATE INTAKE HOSE OPTIONS

The eductor is shipped with a 1.25" x 8' black, industrial grade, UV resistant hose with a 1.0" camlock connection. A 1.25" x 8' clear, flexible hose is available as a secondary option. To order, call 800-348-2686 and ask for part # UE950.

A camlock adaptor is available for those who wish to use a hose with a 1.5" female camlock connection. To order, call 800-348-2686 and ask for part #UE960-KIT.

## 4.0 FOAM SELECTION

Actual foam concentrations vary with changes in water flow, foam concentrate temperature and viscosity. The user must verify that the concentrate's performance is suitable for use in their application. In all cases, the manufacturer's recommendations must be followed.

**CAUTION** Class A foam concentrates are generally less viscous than Class B foam concentrates. Using 1% Class B foam percentage setting to educt Class A foam, may cause the actual Class A foam percentage to be more than 1%.

## 4.1 CLASS A FOAM

It is recommended that the Class A foam used meets USDA Forest Service 5100-307A "Specification for Fire Suppressant Foam for Wildland Firefighting (Class A Foam)", NFPA 298 "Fire Fighting Foam Chemicals for Class A Fuels in Rural, Suburban, and Vegetated Areas", or NFPA 1150 "Foam Chemicals for Fires in Class A Fuels".

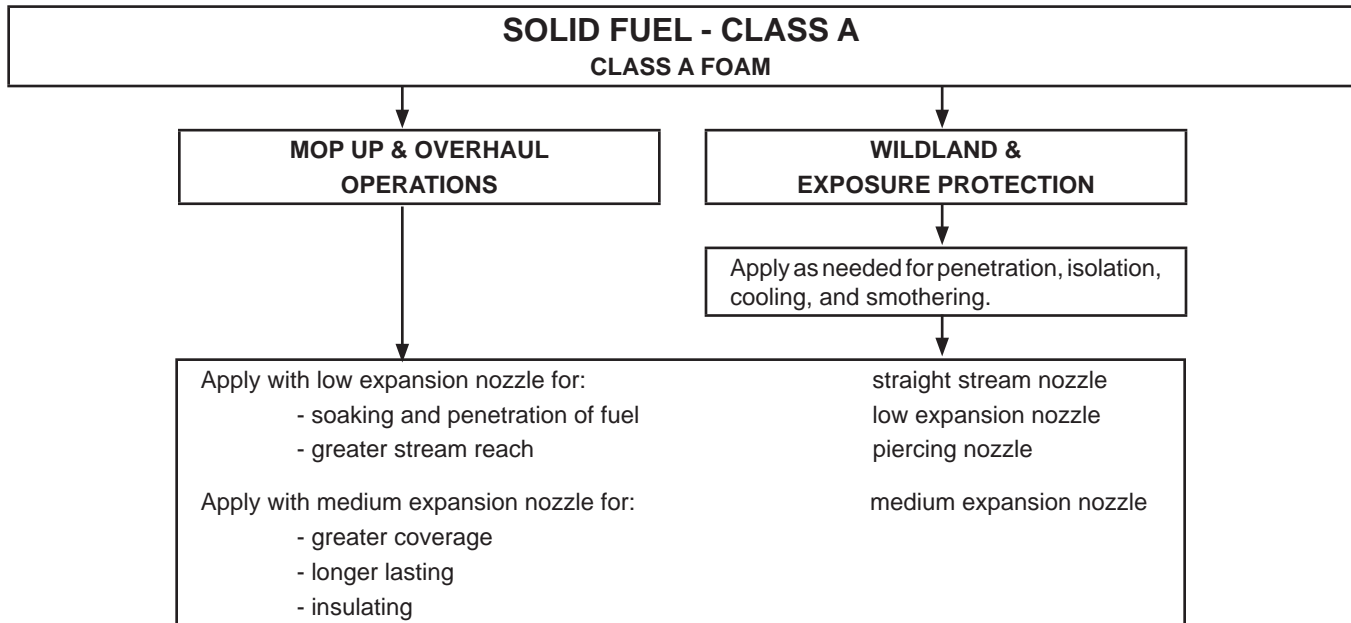

## 4.2 CLASS B FOAM

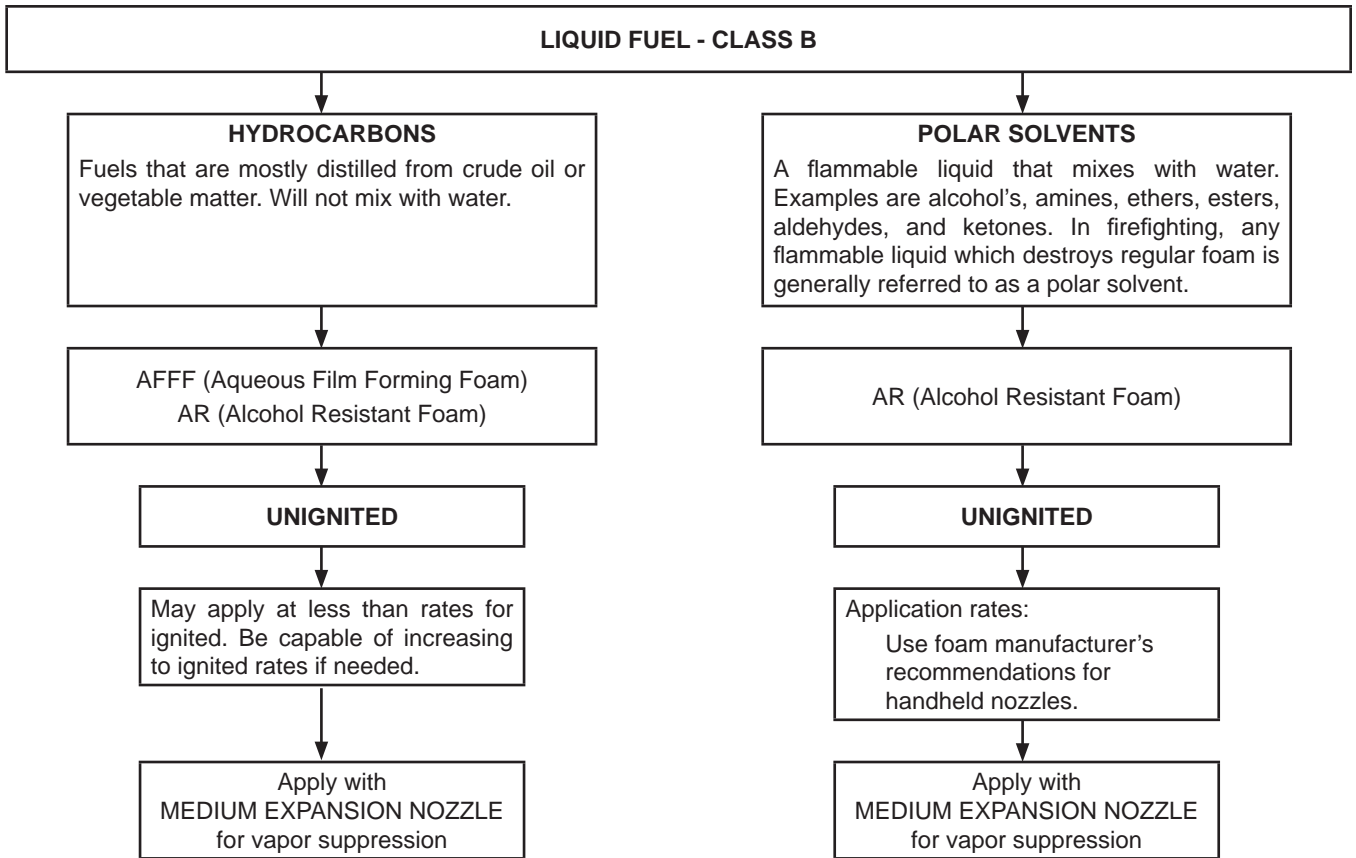

## 4.3 FOAM COMPATIBILITY

**CAUTION** Do not mix different types of foam concentrates or foams of the same type from different manufacturers. Mixing of foam concentrates can cause the contents of the foam tank to gel and produce unpredictable results. Clean tank and foam passages thoroughly when changing foam types.

**Medium Expansion Nozzle** — produces the greatest expansion ratios. It should be used on Class B fuels for vapor suppression and Class A fuels when a longer lasting insulating layer of drier foam is desired.

**Low Expansion Nozzle** — can be used with either Class A or B foam solutions. Reach is slightly less than the smooth bore. It should be used on Class B fires for extinguishment and Class A fuels to soak the fuel with a wet foam solution.

**Straight Stream Nozzle** — is for Class A foam solutions. Foam expansion will be negligible. It should be used where maximum reach or penetration is desired.

## 4.4 FOAM CONSUMPTION

The following tables indicate the theoretical foam concentrate flow rate and the time it will take to empty a 5 gallon container of various concentrates with eductors of different ratings.

**250 GPM Eductor**

Setting	Foam Class	Time To Empty 5 Gallons	Foam Flow Rate in GPM
1/2%	A	4 min	1.25
1%	B	2 min	2.5
3%	B	40 sec	7.5
6%	B	20 sec	15

**350 GPM Eductor**

Setting	Foam Class	Time To Empty 5 Gallons	Foam Flow Rate in GPM
1/2%	A	2 min 54 sec	1.75
1%	B	1 min 26 sec	3.5
3%	B	29 sec	10.5
6%	B	14 sec	21

### 800 LPM Eductor

Setting	Foam Class	Time To Empty 20 Liters	Foam Flow Rate in LPM
1/2%	A	5 min	4
1%	B	2 min 30 sec	8
3%	B	50 sec	24
6%	B	25 sec	48

### 1500 LPM Eductor

Setting	Foam Class	Time To Empty 20 Liters	Foam Flow Rate in LPM
1/2%	A	2 min 40 sec	7.5
1%	B	1 min 20 sec	15
3%	B	27 sec	45
6%	B	13 sec	90

### 1000 LPM Eductor

Setting	Foam Class	Time To Empty 20 Liters	Foam Flow Rate in LPM
1/2%	A	4 min	5
1%	B	2 min	10
3%	B	40 sec	30
6%	B	20 sec	60

### Actual calibrated rate for each setting and the foam concentration used for calibration

Setting	Actual Rate	Foam Class	UL-162 Tolerance
1/2%	0.58%	A	.5 - .65%%
1%	1.15%	B	1 - 1.3%
3%	3.45%	B	3 - 3.9%
6%	6.50%	B	6 - 7.8%

The Class B foam used for calibration is the "Universal Gold 1%/3% Alcohol Resistant Aqueous Film Forming Foam (AR-AFFF)" from National Foam. The calibration viscosity is 2500 centipoise tested with Brookfield #4 Spindle @ 60 rpm

The calibration hose length is 50ft.

## 5.0 MAXIMUM HOSE LAY

The maximum hose lay is based on the back pressure. Pushing the foam solution through the hose and eductor causes back pressure on the eductor exit. If the back pressure on a 200 psi (14 bar) nozzle is over 130 psi (9 bar) the eductor will not work. If the back pressure on the 150 psi (10 bar) eductor is over 80 psi (5.5 bar), the eductor will not work.

Elevation loss adds to the back pressure when the nozzle is higher than the eductor. For each foot in vertical height, there is 0.4 psi elevation loss.

**⚠ WARNING** Do not exceed the maximum back pressure. Excess back pressure causes loss of foam flow resulting in risk of injury or death from an ineffective stream. Verify that adequate foam flow is established and maintained.

The eductor can be used with or without a monitor. The maximum hose lays and elevations change due to the different friction losses in the monitors. Please use the appropriate chart for the inlet pressure and the appropriate portable monitor if one is used. To use in a permanent installation with another monitor, calculate friction loss in pipes and elevation changes to find correct setup. To calculate back pressure, add the nozzle pressure, hose friction loss, and elevation pressure loss together, and make sure the sum does not exceed 130 psi (9 bar) or 80 psi (5.5 bar) depending on the model. The Go/No-Go pressure gage on the outlet of the unit indicates acceptable back pressure levels. Should the gage show a pressure in the No-Go (red) range, shut down the line and change the line setup to lower the pressure.

NOTE: Low pressure 150psi (10 bar) eductors are only compatible with 55 psi (4 bar) nozzles.

NOTE: Metric version eductors are only compatible with 4bar nozzles, and do not work with the Partner and Partner-Lite monitors.



WITHOUT MONITOR							
Eductor Rating	Hose Size	100 PSI Nozzle		80 PSI Nozzle		55 PSI Nozzle	
		Maximum Hose Lay	Maximum Elevation	Maximum Hose Lay	Maximum Elevation	Maximum Hose Lay	Maximum Elevation
	IN	FT	FT	FT	FT	FT	FT
250 GPM at 200 PSI	2.5	200	0	350	0	550	0
		100	20	200	40	300	75
		-	-	100	80	150	125
	3	500	0	900	0	900	50
		250	25	600	30	600	90
		-	-	300	60	300	125
350 GPM at 200 PSI	2.5	100	0	200	0	300	0
		50	25	100	50	200	50
		-	-	50	75	100	100
	3	250	0	450	0	700	10
		100	30	200	50	450	60
		-	-	100	75	200	125
250 GPM at 150 PSI	2.5	-	-	-	-	150	0
		-	-	-	-	100	15
		-	-	-	-	50	30
	3	-	-	-	-	400	0
		-	-	-	-	200	25
		-	-	-	-	100	40
350 GPM at 150 PSI	2.5	-	-	-	-	100	0
		-	-	-	-	75	5
		-	-	-	-	50	15
	3	-	-	-	-	250	0
		-	-	-	-	150	10
		-	-	-	-	75	25

WITH BLITZFIRE							
Eductor Rating	Hose Size	100 PSI Nozzle		80 PSI Nozzle		55 PSI Nozzle	
		Maximum Hose Lay	Maximum Elevation	Maximum Hose Lay	Maximum Elevation	Maximum Hose Lay	Maximum Elevation
	IN	FT	FT	FT	FT	FT	FT
250 GPM at 200 PSI	2.5	100	0	250	0	450	0
		50	10	100	30	300	40
		-	-	50	60	150	80
	3	225	0	600	0	600	50
		0	25	300	30	400	80
		-	-	100	60	100	110
350 GPM at 200 PSI	2.5	50	0	125	0	200	0
		25	10	100	10	100	60
		-	-	80	25	50	90
	3	125	0	300	0	500	10
		75	10	200	25	300	60
		-	-	100	50	100	100
250 GPM at 150 PSI	2.5	-	-	-	-	50	0
		-	-	-	-	25	10
		-	-	-	-	0	15
	3	-	-	-	-	100	0
		-	-	-	-	50	10
		-	-	-	-	25	15
350 GPM at 150 PSI	2.5	-	-	-	-	25	0
		-	-	-	-	15	5
		-	-	-	-	10	10
	3	-	-	-	-	75	0
		-	-	-	-	50	5
		-	-	-	-	25	10

WITH CROSSFIRE							
Eductor Rating	Hose Size	100 PSI Nozzle		80 PSI Nozzle		55 PSI Nozzle	
		Maximum Hose Lay	Maximum Elevation	Maximum Hose Lay	Maximum Elevation	Maximum Hose Lay	Maximum Elevation
	IN	FT	FT	FT	FT	FT	FT
250 GPM at 200 PSI	2.5	150	0	350	0	500	0
		75	30	200	40	350	50
		-	-	100	60	100	120
	3	300	0	600	0	900	50
		100	40	300	50	450	100
		-	-	100	75	100	130
350 GPM at 200 PSI	2.5	80	0	175	0	250	0
		50	20	100	40	175	60
		-	-	80	50	100	100
	3	225	0	400	0	600	10
		100	30	250	40	300	75
		-	-	100	75	100	125
250 GPM at 150 PSI	2.5	-	-	-	-	350	0
		-	-	-	-	250	25
		-	-	-	-	100	60
	3	-	-	-	-	800	0
		-	-	-	-	400	50
		-	-	-	-	100	80
350 GPM at 150 PSI	2.5	-	-	-	-	175	0
		-	-	-	-	100	30
		-	-	-	-	50	75
	3	-	-	-	-	400	0
		-	-	-	-	250	40
		-	-	-	-	100	75

With Crossfire - Metric			
Eductor Rating	Hose Size	4 BAR Nozzle	
		Maximum Hose Lay	Maximum Elevation
	mm	M	M
800 l/min at 10 bar	65	40	0
		25	3
		10	6
	77	100	0
		70	2
		30	5
1000 l/min at 10 bar	65	25	0
		15	3
		10	5
	77	60	0
		30	4
		10	6
1500 l/min at 10 bar	65	10	0
		5	4
		0	8
	77	25	0
		15	3
		10	5

Without Monitor - Metric			
Eductor Rating	Hose Size	4 BAR Nozzle	
		Maximum Hose Lay	Maximum Elevation
	LPM	M	M
800 l/min at 10 bar	65	55	0
		25	6
		10	9
	77	140	0
		100	3
		50	7
1000 l/min at 10 bar	65	35	0
		25	3
		10	8
	77	75	2
		50	5
		25	8
1500 l/min at 10 bar	65	15	0
		10	4
		5	8
	77	40	0
		15	6
		10	8

Friction loss varies with different brand hoses. Please determine the friction loss of your own hose. The nominal flow of the eductor is the sum of the water plus the foam concentrate when set at 6%. The eductor should always have 200 psi (14 bar) at the inlet unless otherwise specified on the eductor body. The water flow does not change with different percentage settings; however the induced concentrate will change when the percentage setting is changed. Therefore, the total flow exiting the eductor is lower at 1/2% than at 6%. Lower flow rate reduces nozzle pressure and hose friction loss. Longer hose can be used when proportioning rate is less because less work is needed to move less concentrate.

## 6.0 NOZZLE SELECTION

Eductors work with any nozzle whose gallonage is equal or larger than eductors'. However, if a larger gallonage nozzle is used, the reach of nozzle and the proportioning rate of the eductor will be compromised.

Fog-type nozzles have the greatest reach in the straight stream position. The finished foam is produced as the stream projects forward, and the greatest expansion is at the end of the stream. While straight stream gives maximum reach, it can also splash flammable liquids if not carefully applied. The stream impact can be softened by deflecting the stream off nearby objects. The stream can also be trimmed to a 10-15 degree pattern which gives good reach and creates a softer "snow-flaking" effect at the end of the stream.

The expansion ratio is the amount of finished foam produced compared to the volume of foam concentrate/water solution used to generate the foam. For example: A 10:1 expansion ratio will production 3500 gallons of finished foam from a 350 GPM nozzle. Non-aspirated automatic nozzles can produce expansion ratios of 6-8:1 when measured at the end of the stream. By maintaining a constant nozzle pressure, automatic nozzles keep the velocity of the stream high. Large amounts of air are pulled into the stream and mix with the foam concentrate/water solution as the stream leaves the nozzle.

Air-aspirating devices, such as the TFT FOAMJET, allow a wider selection of foam concentrates to be used, and can produce a better quality of finished foam. Air-aspirating attachments will, (1) improve the 1/4 drain time, (2) produce a more uniform bubble structure, (3) improve the burn back resistance of the finished foam, and (4) the foam blanket is visibly thicker. This thicker foam blanket has better vapor suppression and is longer lasting than foam from non-aspirated nozzles. The final expansion ratio and, therefore, the amount of finished foam, depends on the type of foam concentrate being used.

**⚠ WARNING** The nozzle must be operated fully open to prevent excessive back pressure which will prevent foam pickup. Lack of foam can result in injury or death.

The following table lists the compatibility between eductors and nozzles. **NOTE: A nozzle under 100 psi will result in lower nozzle pressure and shorter stream reach.**

### 350 SERIES EDUCTORS

Nozzle Name	Nozzle Model #	Water Flow Setting GPM	Nozzle Pressure PSI	Low Expansion Foam Attachment	Multi-Expansion Foam Attachment
<b>Max-Force</b>	MD*2A	100-500	100 or 55	FJ-LX-MD	NONE
	MD-ERP-*2A	100-500	100 or 55		
	MD-ER-*2A	100-500	100 or 55		
<b>Max-Matic</b>	MD*8A	100-500	100 or 55	FJ-LX-MD	NONE
	MD-ERP-*8A	100-500	100 or 55		
	MD-ER-*8A	100-500	100 or 55		
	MD*7A	100-500	80		
<b>Max-Flow</b>	MD*4A	100-500	100 to 30	FJ-LX-MD	NONE
	MD-ERP-*4A	100-500	100 to 30		
	MD-ER-*4A	100-500	100 to 30		

## 7.0 TROUBLE-SHOOTING

SYMPTOM	POSSIBLE CAUSE	REMEDY
Eductor picks up too much foam	Percentage Knob is set at higher percentage than desired	Turn knob to desired percentage
	Eductor inlet pressure is incorrect	Set eductor inlet pressure to pressure specified on labels
	Metering head paired with incorrect body	Use correct metering head for body
Weak Foam or No Foam	Out of foam or bucket is nearly empty	Refill tank
	Percentage knob is set to lower percentage or is set to OFF	Turn knob to desired percentage
	Percentage ball is partially or completely plugged	Take off the meter head and clean debris out of the percentage ball
	Hose lay is incorrect	Correct hose lay using Section 5.0
	Eductor inlet pressure is incorrect	Set eductor inlet pressure to pressure specified on labels
	Hose is kinked	Straighten kinks out of hose
	Concentrate intake hose is completely or partially clogged	Clean debris out of concentrate intake hose
	Valve in nozzle is not fully open	Fully open valve in nozzle
	Nozzle size is incorrect	Select correct nozzle using Section 6.0
	Nozzle is clogged	Flush nozzle to clear out debris or remove nozzle to clean debris out
	Foam has thickened due to cold temperatures	Use a foam suitable for temperatures

## 8.0 DRAWING AND PARTS LIST

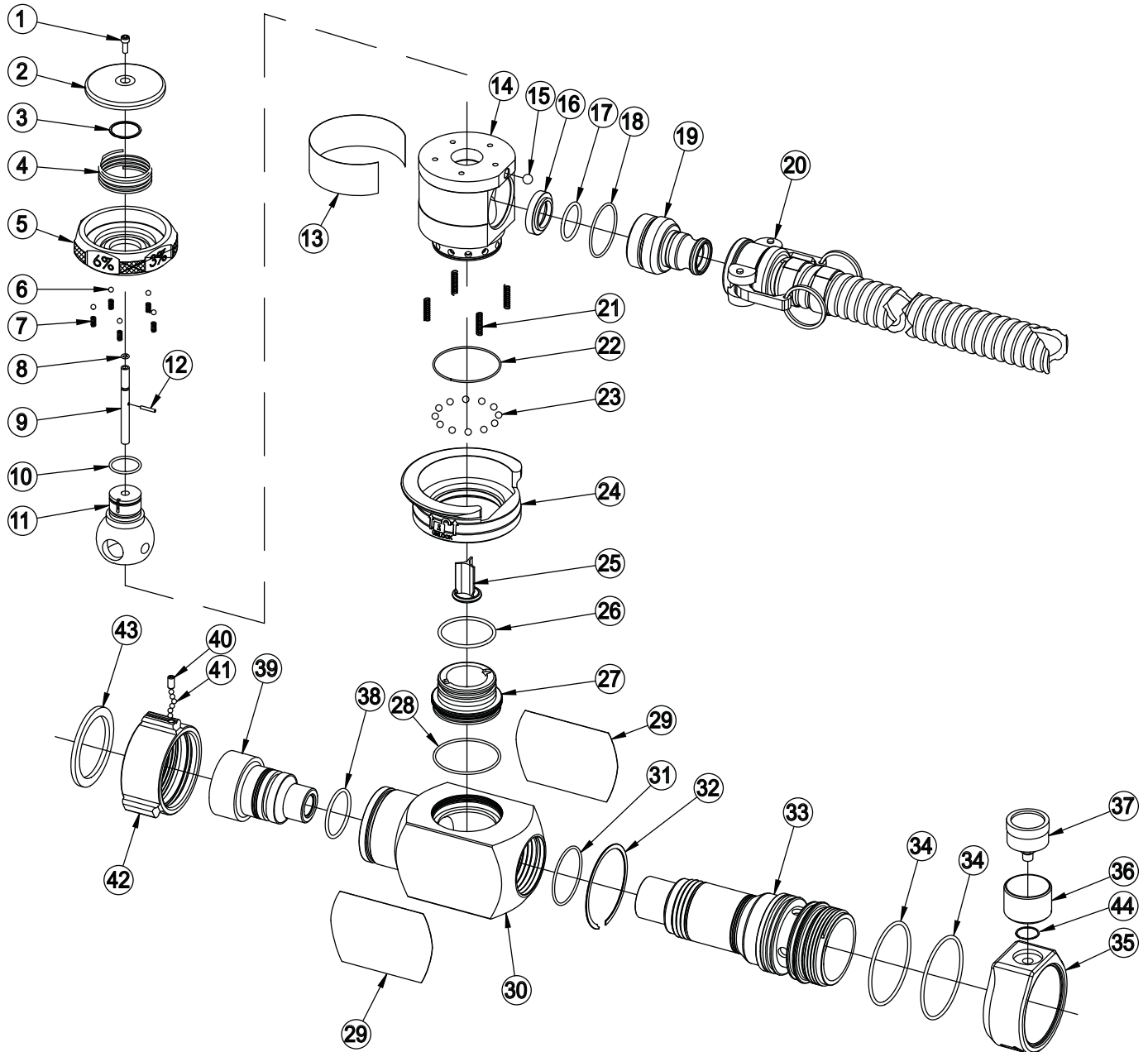

ITEM	DESCRIPTION	QTY	PART #
1	10-24 X 1/2 SOCKET HEAD SCREW	1	VT10-24SH500
2	PALM BUTTON 2.5" EDUCTOR	1	UE550
3	SMALLEY RING	1	VR4315
4	BUTTON SPRING 2.5" EDUCTOR	1	UE505
5	KNOB 2.5" EDUCTOR	1	UE540
6	3/16" TORLON BALL	5	V2120-TORLON
7	SPRING HELICAL COMPRESSION	5	VM4195
8	O-RING-008	1	VO-008
9	BACK FLUSH PIN	1	UE220
10	O-RING-121	1	VO-121
11	PROPORTIONING BALL 250 GPM	1	UE530
	PROPORTIONING BALL 350 GPM		UE531
	PROPORTIONING BALL 800 LPM		UE534
	PROPORTIONING BALL 1000 LPM		UE532
	PROPORTIONING BALL 1500 LPM		UE533
12	SPIROL PIN	1	VP109X625H
13	METER LABEL 250 GPM	1	UL600
	METER LABEL 350 GPM		UL601
	METER LABEL 250 GPM 150 PSI		UL602
	METER LABEL 350 GPM 150 PSI		UL603
	METER LABEL 800 LPM		UL606
	METER LABEL 1000 LPM		UL604
	METER LABEL 1500 LPM		UL605
14	METER HEAD 2.5" EDUCTOR	1	UE535
15	BALL 3/8" - POLYETHYLENE	1	VB375PE
16	PROP. BALL SEAT 2.5" EDUCTOR	1	UE635
17	O-RING-219	1	VO-219
18	O-RING-136	1	VO-136
19	CAMLOCK CONNECTOR	1	UE613
20	8' HOSE WITH CAMLOCK	1	UE940
21	LOCKER RING SPRING 2.5" EDUCTOR	4	UE515
22	LOCATION RING 2.5" EDUCTOR	1	UE545
23	1/4" SS BALL	12	V2125
24	HEAD LOCKER 2.5" EDUCTOR	1	UE510
25	CHECK DISK 2.5" EDUCTOR	1	UE525
26	O-RING 226	1	VO-226
27	INTERSECTION CONNECTION	1	UE440
28	O-RING-143	1	VO-143

ITEM	DESCRIPTION	QTY	PART #
29	NAME LABEL 250 GPM	2	UL610
	NAME LABEL 350 GPM		UL611
	NAME LABEL 250 GPM 150 PSI		UL612
	NAME LABEL 350 GPM 150 PSI		UL613
	NAME LABEL 800 LPM		UL616
	NAME LABEL 1000 LPM		UL614
	NAME LABEL 1500 LPM		UL615
30	INTERSECTION 2.5" EDUCTOR	1	UE420
31	O-RING-139	1	VO-139
32	SMALLEY RING	1	VR4320
33	EXIT 250 GPM 2.5"NH	1	UE400N
	EXIT 250 GPM 2.5"NPSH		UE400I
	EXIT 350 GPM 2.5"NH		UE401N
	EXIT 350 GPM 2.5"NPSH		UE401I
	EXIT 250 GPM 150 PSI 2.5"NH		UE402N
	EXIT 250 GPM 150 PSI 2.5"NPSH		UE402I
	EXIT 350 GPM 150 PSI 2.5"NH		UE403N
	EXIT 350 GPM 150 PSI 2.5"NPSH		UE403I
	EXIT 800 LPM 2.5"BSP		UE406B
	EXIT 1000 LPM 2.5"BSP		UE404B
EXIT 1500 LPM 2.5"BSP	UE405B		
34	O-RING-235	2	VO-235
35	SWIVELING PRESSURE GAGE RING	1	UE430
36	GAGE PROTECTOR	1	UE450
37	GO/NO-GO GAGE 200 PSI	1	UE650
	GO/NO-GO GAGE 150 PSI		UE655
38	O-RING-224	1	VO-224
39	BLENDING TUBE 250 GPM	1	UE410
	BLENDING TUBE 350 GPM		UE411
	BLENDING TUBE 250 GPM 150 PSI		UE412
	BLENDING TUBE 350 GPM 150 PSI		UE413
	BLENDING TUBE 800 LPM		UE416
	BLENDING TUBE 1000 LPM		UE414
	BLENDING TUBE 1500 LPM		UE415
40	1/4-28 X 1/2 SOCKET SET SCREW	1	VT25-28SS500
41	3/16" SS BALL	48	V2120
42	COUPLING 2.5"NH	1	M307N
	COUPLING 2.5"NPSH		M307I
43	GASKET	1	V3190
44	O-RING-313	1	VO-313



**Do not intermix metering heads with eductor bodies of different flow rates. Intermixing can cause weaker or stronger foam than expected resulting in risk of injury as the ability to control the fire is compromised.**

## 9.0 FOAM BUCKET ARRANGEMENTS

The foam suction hose is matched to the eductor and must not be lengthened or foam flow will be reduced resulting in weak foam. (as shown in location D). The other three locations (A, B, & C) show the recommended foam bucket arrangement.

LOCATION A

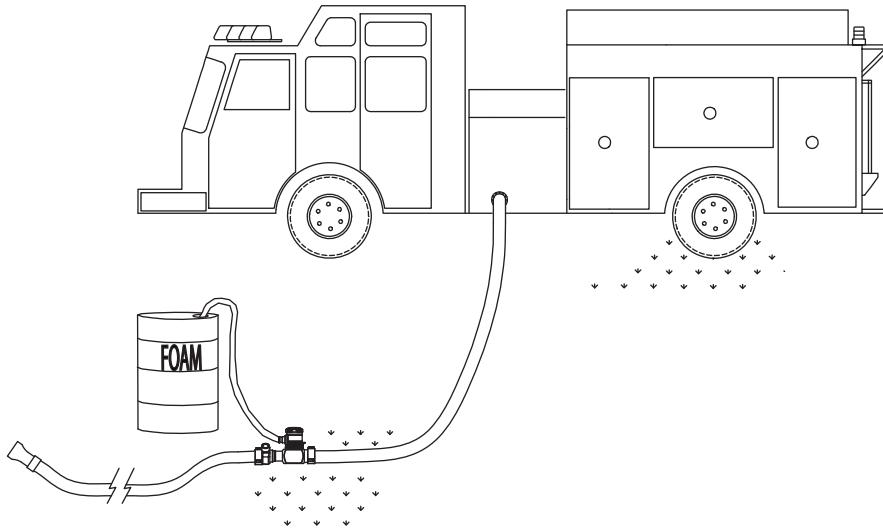

LOCATION B

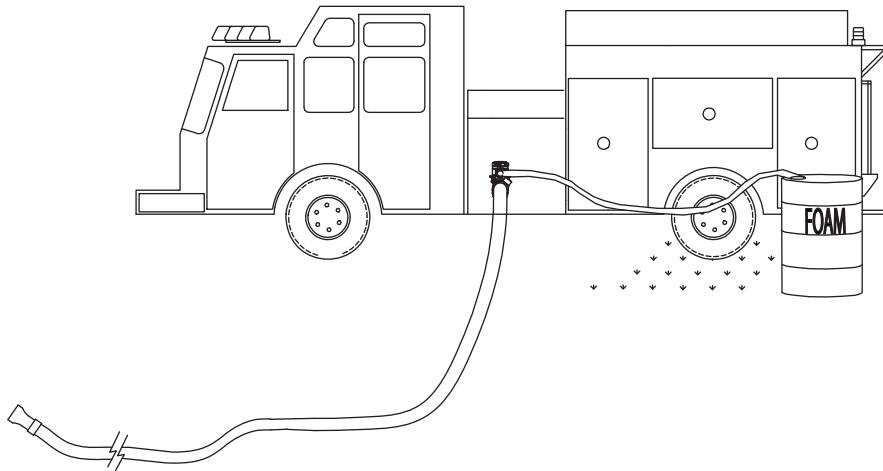

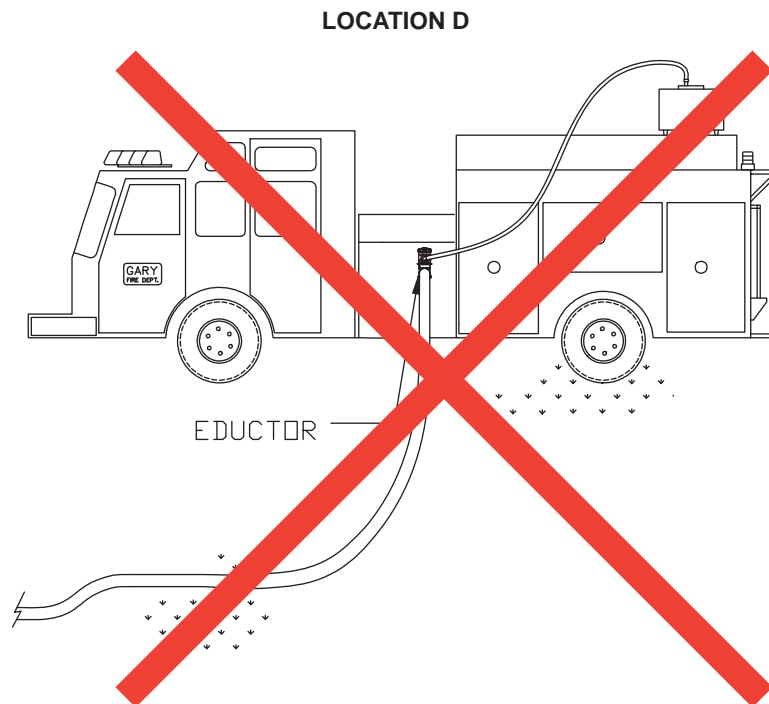
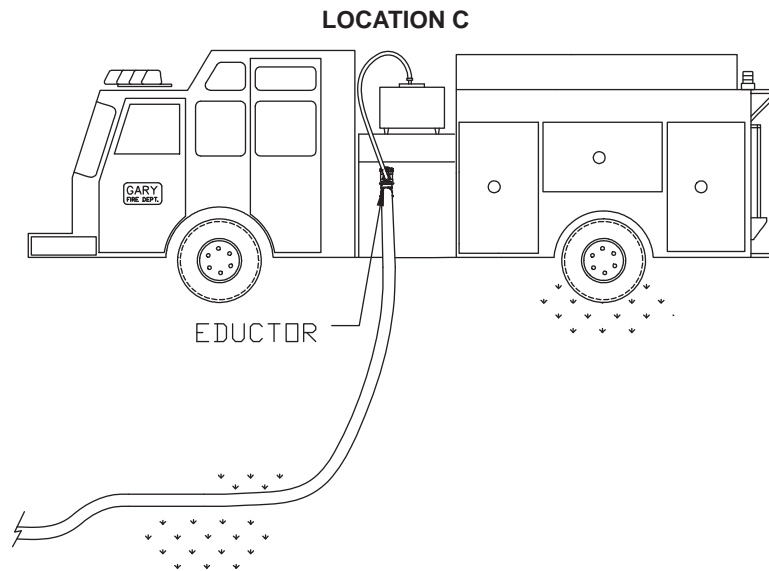

## 9.1 FOAM SUPPLY LOGISTICS

When using Class B foams for extinguishing burning pools of liquids a continuous foam supply is essential. Foam flow may be interrupted by not changing foam buckets quickly or by switching the metering head to OFF. Foam buckets can be difficult to move or open quickly, therefore training and planning for a continuous foam supply is recommended.

**⚠ DANGER**

**Lack of foam can place operator at risk of injury or death. Establish foam flow before advancing into hazardous situations. Make sure you do not run out of foam concentrate before the task is complete. Check concentrate level periodically and keep an adequate supply on hand.**

## 10.0 MAINTENANCE

The eductor does not need regular maintenance. However, make sure the eductor is completely cleaned after each use. Otherwise the foam concentrate may dry inside and around the percentage ball resulting in plugged metering orifices. Look down inside the metering head after flushing and check valve to ensure clean passageways.

## 11.0 WARRANTY

Task Force Tips, Inc., 3701 Innovation Way, Valparaiso, Indiana 46383-9327 USA ("TFT") warrants to the original purchaser of its nozzles and other equipment ("equipment"), and to anyone to whom it is transferred, that the equipment shall be free from defects in material and workmanship during the five (5) year period from the date of purchase.

TFT's obligation under this warranty is specifically limited to replacing or repairing the equipment (or its parts) which are shown by TFT's examination to be in a defective condition attributable to TFT. To qualify for this limited warranty, the claimant must return the equipment to TFT, at 3701 Innovation Way, Valparaiso, IN 46383-9327 USA, within a reasonable time after discovery of the defect. TFT will examine the equipment. If TFT determines that there is a defect attributable to it, TFT will correct the problem within a reasonable time. If the equipment is covered by this limited warranty, TFT will assume the expenses of repair.

If any defect attributable to TFT under this limited warranty cannot be reasonably cured by repair or replacement, TFT may elect to refund the purchase price of the equipment, less reasonable depreciation, in complete discharge of its obligations under this limited warranty. If TFT makes this election, claimant shall return the equipment to TFT free and clear of any liens and encumbrances.

This is a limited warranty. The original purchaser of the equipment, any person to whom it is transferred, and any person who is an intended or unintended beneficiary of the equipment, shall not be entitled to recover from TFT any consequential or incidental damages for injury to person and/or property resulting from any defective equipment manufactured or assembled by TFT. It is agreed and understood that the price stated for the equipment is in part consideration for limiting TFT's liability. Some states do not allow the exclusion or limitation of incidental or consequential damages, so the above may not apply to you.

TFT shall have no obligation under this limited warranty if the equipment is, or has been, misused or neglected (including failure to provide reasonable maintenance) or if there have been accidents to the equipment or if it has been repaired or altered by someone else.

**THIS IS A LIMITED EXPRESS WARRANTY ONLY. TFT EXPRESSLY DISCLAIMS WITH RESPECT TO THE EQUIPMENT ALL IMPLIED WARRANTIES OF MERCHANTABILITY AND ALL IMPLIED WARRANTIES OF FITNESS FOR A PARTICULAR PURPOSE. THERE IS NO WARRANTY OF ANY NATURE MADE BY TFT BEYOND THAT STATED IN THIS DOCUMENT.**

This limited warranty gives you specific legal rights, and you may also have other rights which vary from state to state.