



MANUAL: DECON/pak Portable Decontamination System

INSTRUCTIONS FOR SAFE OPERATION AND MAINTENANCE

⚠ WARNING

Read instruction manual before use. Operation of this device without understanding the manual and receiving proper training is a misuse of this equipment. Users who have not read and understood all operating and safety instructions are not qualified to operate this portable agent system. This instruction manual is intended to familiarize firefighters and maintenance personnel with the operation, servicing, and safety procedures associated with the DECON/pak Portable Decontamination System. This manual should be kept available to all operating and maintenance personnel.

⚠ WARNING

Improper use of agent can result in injury or damage to the environment. Follow the agent concentrate manufacturer's instructions and fire service training to avoid using the wrong type of agent for decontamination purposes.

⚠ WARNING

There is a wide variety of agent concentrates. Each user is responsible for verifying that any agent concentrate chosen to be used with this unit has been tested to assure that the agent obtained is suitable for the purpose intended.

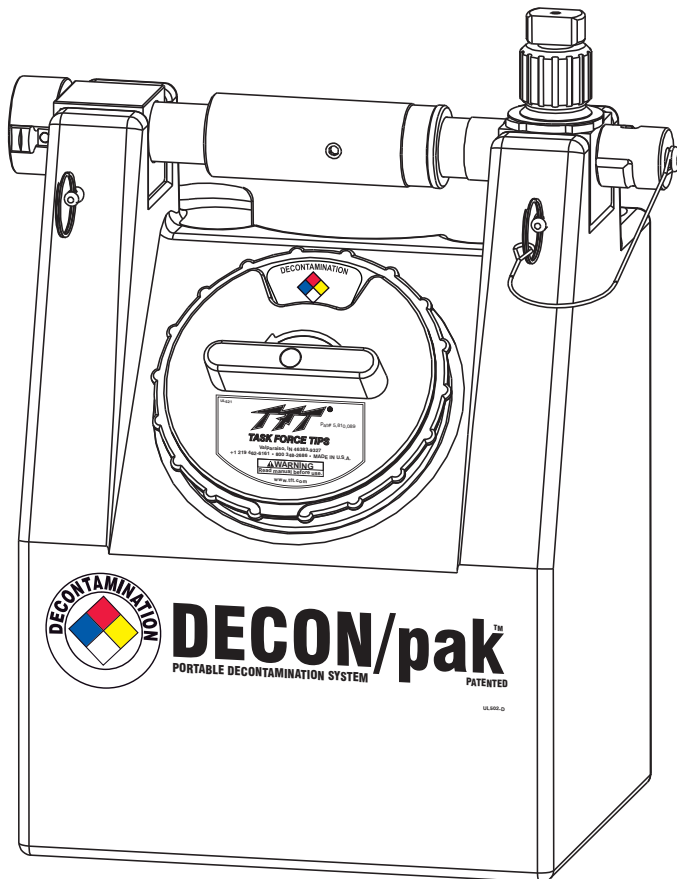

RATED FLOW
12 GPM at 100 PSI
45 L/MIN at 6.8 BAR

Minimum Operating Condition
7 GPM at 40 PSI
30 L/MIN at 3 BAR

Maximum Operating Condition
27 GPM at 500 PSI
100 L/MIN at 40 BAR

TASK FORCE TIPS, INC.
MADE IN USA • www.tft.com

3701 Innovation Way, Valparaiso, IN 46383-9327 USA
800-348-2686 • 219-462-6161 • Fax 219-464-7155



PERSONAL RESPONSIBILITY CODE

The member companies of FEMSA that provide emergency response equipment and services want responders to know and understand the following:

1. Firefighting and Emergency Response are inherently dangerous activities requiring proper training in their hazards and the use of extreme caution at all times.
2. It is your responsibility to read and understand any user's instructions, including purpose and limitations, provided with any piece of equipment you may be called upon to use.
3. It is your responsibility to know that you have been properly trained in Firefighting and /or Emergency Response and in the use, precautions, and care of any equipment you may be called upon to use.
4. It is your responsibility to be in proper physical condition and to maintain the personal skill level required to operate any equipment you may be called upon to use.
5. It is your responsibility to know that your equipment is in operable condition and has been maintained in accordance with the manufacturer's instructions.
6. Failure to follow these guidelines may result in death, burns or other severe injury.







Fire and Emergency Manufacturers and Service Association
P.O. Box 147, Lynnfield, MA 01940 • www.FEMSA.org

Table Of Contents

- 1.0 MEANING OF SIGNAL WORDS
- 2.0 SAFETY
- 3.0 GENERAL INFORMATION
 - 3.1 PART IDENTIFICATION
 - 3.2 LEFT or RIGHT HAND OPERATION
- 4.0 AGENT SELECTION
 - 4.1 AGENT COMPATIBILITY
- 5.0 OPERATION
 - 5.1 HOSE CONNECTION
 - 5.2 FILLING TANK
 - 5.3 CONNECT DISCHARGE HOSE AND NOZZLE
 - 5.4 SETTING AGENT CONCENTRATION
 - 5.5 CONTROLLING FLOW
 - 5.6 AGENT QUALITY
 - 5.7 SHUT DOWN AFTER USE (FLUSHING)
 - 5.8 STORAGE
- 6.0 TROUBLE-SHOOTING
- 7.0 CLEAN UP AND MAINTENANCE
 - 7.1 DRAIN HOLE
- 8.0 SPECIFICATIONS
- 9.0 DRAWINGS AND PARTS LIST
- 10.0 WARRANTY





1.0 MEANING OF SAFETY SIGNAL WORDS

A safety related message is identified by a safety alert symbol and a signal word to indicate the level of risk involved with a particular hazard. Per ANSI standard Z535.6-2006, the definitions of the four signal words are as follows:

-  **DANGER** indicates a hazardous situation which, if not avoided, will result in death or serious injury.
-  **WARNING** indicates a hazardous situation which, if not avoided, could result in death or serious injury.
-  **CAUTION** indicates a potentially hazardous situation which, if not avoided, may result in minor or moderate injury.
-  **NOTICE** is used to address practices not related to personal injury.

2.0 SAFETY

This portable decontamination system can be used in potentially dangerous situations. The following must be observed at all times:

-  **WARNING** Avoid directing agent onto the faces of yourself and other personnel. Improper use of agent could result in death or serious injury, including damage to the eyes. To reduce the chance of injury, have yourself and other personnel wear eye protection at all times.
-  **WARNING** Make sure that the agent concentrate in the tank is the right type for the situation. (Refer to agent concentrate manufacturer's recommendations for proper agent choice.)
-  **WARNING** Agent concentrates can be ineffective if not used at the correct percentage. Make sure that the Percentage Knob is set to the correct concentration for the type of agent being used.
-  **CAUTION** Make sure the Flow Control Valve is off and the correct nozzle and Outlet Hose are securely attached to the Control Block before the hose line is charged.

3.0 GENERAL INFORMATION

The DECON/pak Portable Decontamination System is a self-contained agent proportioning and rinse application system developed specifically for gross decontamination of firefighting personnel and equipment. Injecting a variety of approved personal protective clothing gross decontamination agents from 0.1% to 0.5%, the rugged green polypropylene 2.5 gallon concentrate tank and is supplied by a pressurized 1" or 1.5" hoseline. The unit includes an integrated twist shut-off valve, selective injection metering knob, and is easily disassembled for cleaning. The pressure vacuum seal on the lid and inlet debris screen assures that the approved decontamination agent chosen can be stored ready for immediate use. A detachable fan spray nozzle is attached to a 12' discharge hose for ease of use during agent application or rinsing operations.

The DECON/pak is not intended to be used for Class A, Class B, or any other type of foam concentrate. If you intend to use the DECON/pak for liquids other than decontamination agents and water, we urge you to contact Task Force Tips Service Department at 800-854-6864. The use of other liquids may void the warranty and subject the user to hazards not addressed in this manual. The user assumes all risks for non intended uses.

**DECON/pak FLOW CHARACTERISTICS
(with valve fully open)**

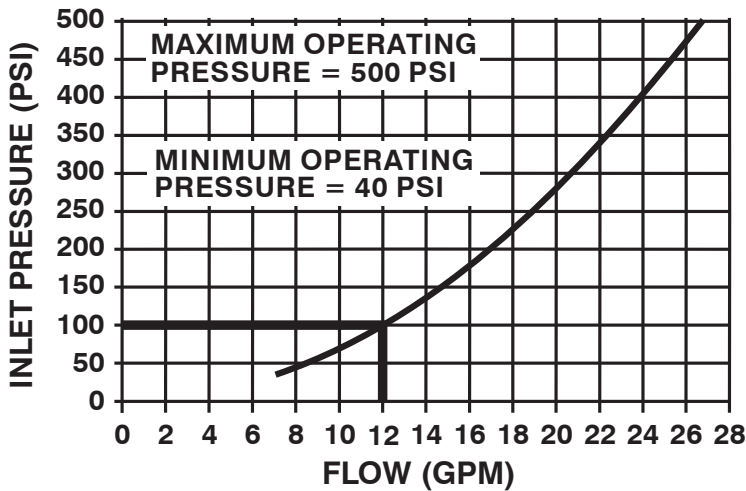

MINUTES TO USE 2½ GALLONS OF CONCENTRATE AT 12 GPM	
PERCENT	MINUTES
0.1	208
0.2	104
0.3	69
0.4	52
0.5	42

**DECON/pak FLOW CHARACTERISTICS
(with valve fully open)**

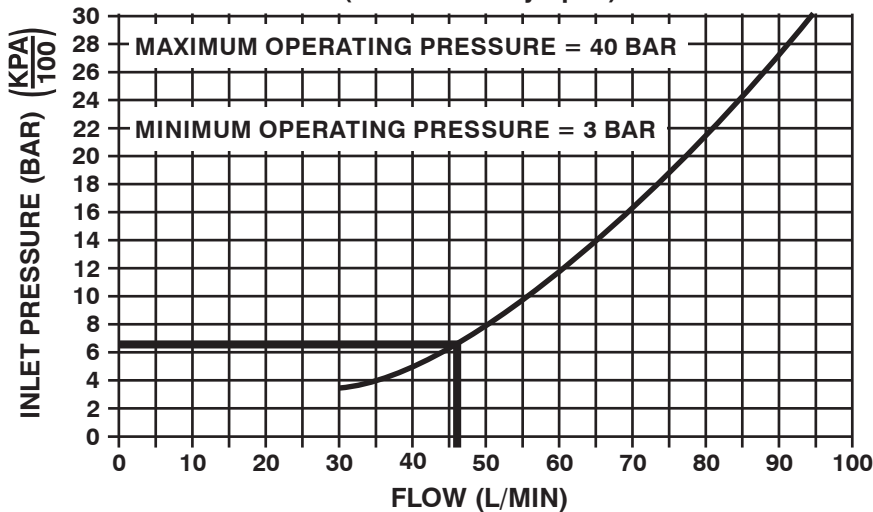

MINUTES TO USE 10 LITERS OF CONCENTRATE AT 45 l/min	
PERCENT	MINUTES
0.1	208
0.2	104
0.3	69
0.4	52
0.5	42

3.1 PART IDENTIFICATION

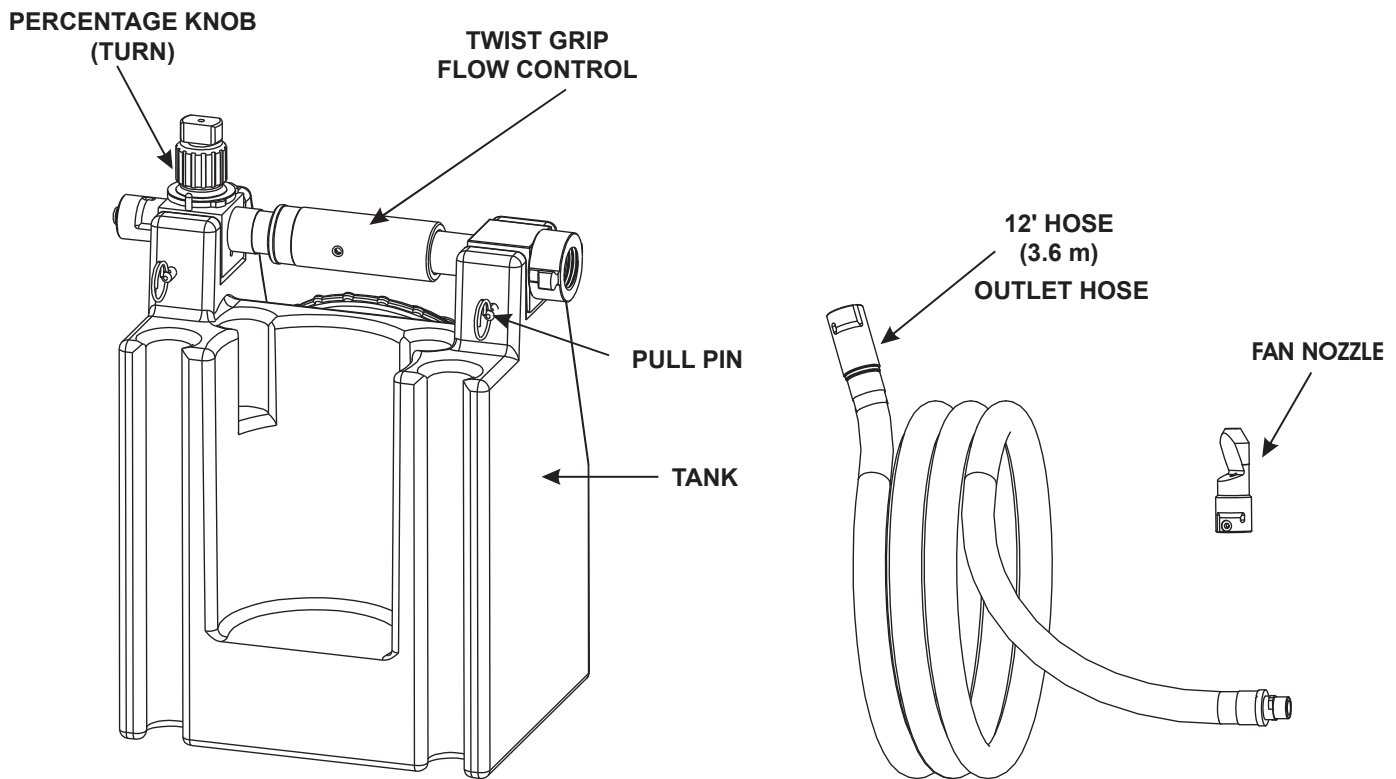

3.2 LEFT or RIGHT HAND OPERATION

The Control Block and Valve Assembly can be mounted on the Tank for right or left hand operation. To switch hands, remove the Shoulder Strap from the Pull Pins. Remove the Circle Cotter from the Pull Pins and remove the Pull Pins themselves. Pull the Control Assembly straight up and out of the tank. Turn the Control Unit around and reinstall the Pull Pins, the Circle Cotter, and the Shoulder Strap.

4.0 AGENT SELECTION

In any eductor type system the accuracy of the agent concentrate to water ratio will depend upon the viscosity (thickness) of the agent concentrate. The more viscous, or thick, the agent concentrate, the greater the amount of energy required to draw the concentrate into the eductor. The viscosity of most agent concentrates changes with temperature, some thickening to a gel at temperatures of 40° F (4° C).

The DECON/pak percentage knob was calibrated with ZepPowerPlex® Heavy-Duty Laundry Detergent. Actual agent concentrations vary with changes in water flow, agent concentrate temperature and viscosity. The user must verify that the concentrate's performance is suitable for use in their application. In all cases, the manufacturer's recommendations must be followed.

4.1 AGENT COMPATIBILITY

⚠ DANGER

Do not mix different types of agent concentrates or agents of the same type from different manufacturers. Mixing of agent concentrates can cause the contents of the agent tank to gel and produce unpredictable results. Clean tank and agent passages thoroughly when changing agent types. Check with your PPE manufacturer for recommendations.

5.0 OPERATION

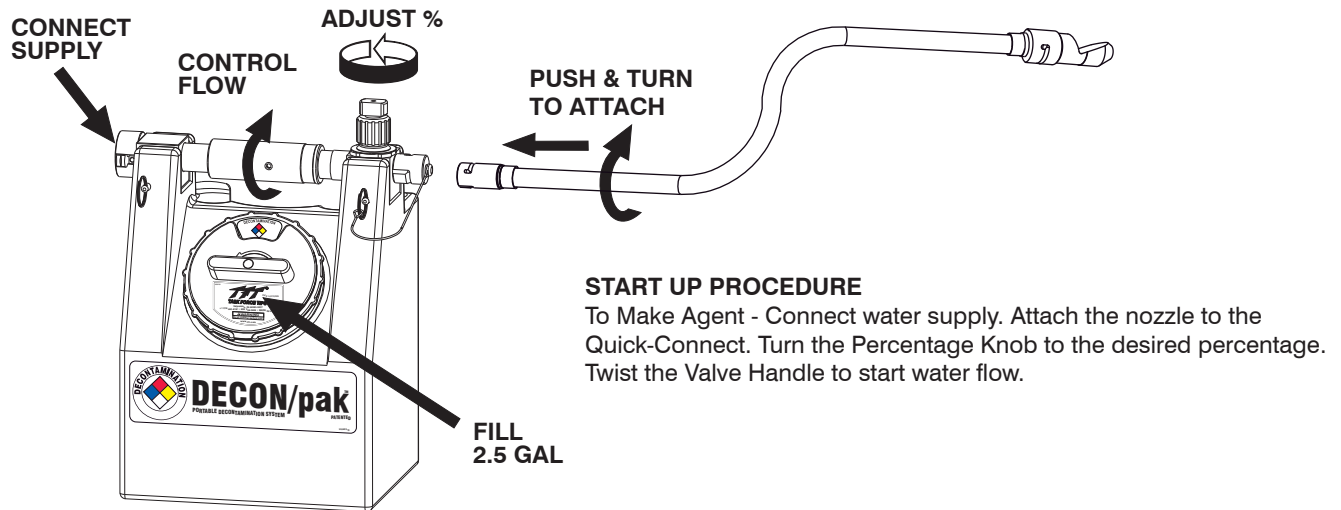

5.1 HOSE CONNECTION

Attach inlet fire hose to the coupling on the inlet end of the DECON/pak. Larger hoses may be used with an adapter. For maximum maneuverability, we recommend attaching 1" hose into the DECON/pak itself.

5.2 FILLING TANK

Unscrew the fill port lid by turning counterclockwise. Fill tank to bottom of fill port. Agent may seep out the vents if over filled. Close the fill port lid by turning clockwise.

5.3 CONNECT DISCHARGE HOSE AND NOZZLE

1. The nozzle may be attached directly to the quick-connect fitting on the control block or to the end of the outlet hose which is then attached to the control block. Align the marks on the quick-connect male fitting with the marks on the female fitting and push the two pieces together. Twist the nozzle or hose one quarter turn to the right to latch the quick-connect fitting.
2. To remove fan nozzle, remove set screw.
3. Hose lengths available. TFT part U-HS6, U-HS, and U-HS25.

CAUTION The DECON/pak's eductor will not work if the backpressure from the outlet hose or nozzle is too high. The 25' (7.5m) U-HS25 optional hose is the maximum length that will work with the DECON/pak. Adding additional hose, or using other hose assemblies and nozzles, may cause the DECON/pak to not function properly.

CAUTION There is no check valve in the DECON/pak eductor system. Do not install a shut off valve between the DECON/pak and the fan nozzle. This can cause the agent tank to fill with water and dilute the agent concentrate.

5.4 SETTING AGENT CONCENTRATION

Turn the knob to the desired concentrate percentage. The percentage knob may be turned to the RINSE position for water only use. Be sure to use the agent manufacturer's recommended concentrate ratio.

5.5 CONTROLLING FLOW

Pressurize the hose line. Turn the flow control valve to start water flowing through the DECON/pak. Flow may be reduced by partially closing the control valve.

5.6 AGENT QUALITY

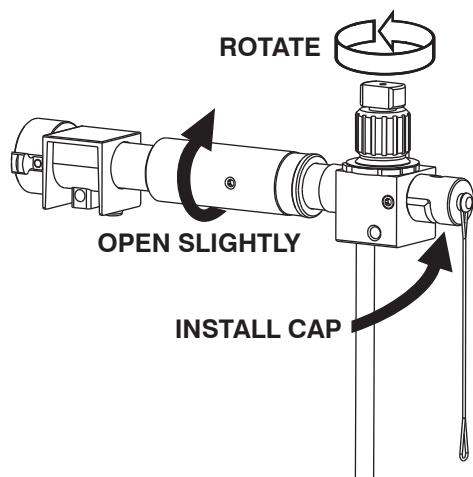

TO SHUT DOWN

To prevent concentrate from drying in the agent passages the following is recommended. While still connected to water supply, remove Circle Cotters and Pull Pins. Remove Control Unit from tank. Attach the Cap directly to the Quick-Connect on the Control Block. Turn the valve half way on till the discharge is agent free. This will back flush a small amount of water through the agent passage. Rotate the Percentage Knob back and forth to make sure all agent passages are flushed.

TO CLEAN OUT IF PLUGGED

Remove screw #2, spring #3, and knob #4. Inspect the underside of the knob. Make sure the agent passages are clear. Do not scratch the flat face of the knob. Inspect the 2 holes in the top of the Control Block #5. If they are plugged, pull pins #1, remove Block Assembly and clean out Pickup Tube and holes.

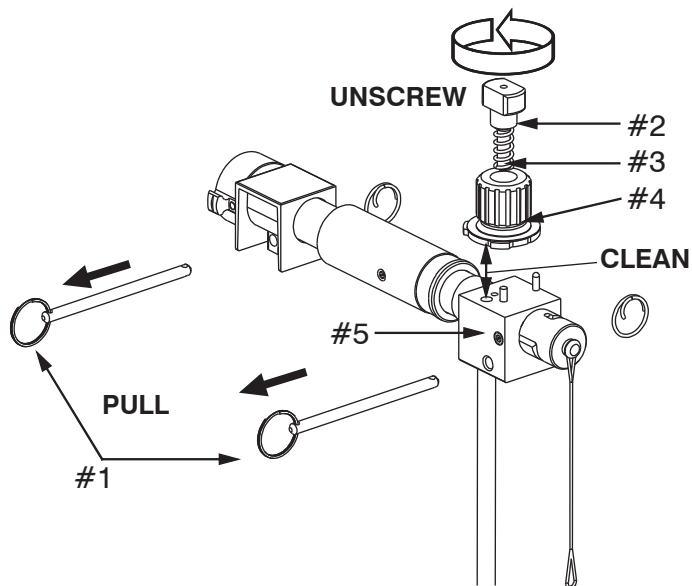

5.7 SHUT DOWN AFTER USE (FLUSHING)

DECON/pak should be flushed with water after each use to prevent agent concentrate from drying out inside of the Control Block and Percentage Knob.

- 1) Reduce pump pressure to 100 psi or less.
- 2) Remove the nozzle and/or hose from the quick-connect on the front of the Control Block.
- 3) Remove the Circle Cotters and pull out the two Pull Pins that hold the Control Unit to the tank.
- 4) Pull straight up to remove the Control Unit and Pickup Tube from the tank.
- 5) Make sure the Percentage Knob is NOT in the RINSE position.
- 6) Install the Cap on the outlet of the Control Block.
- 7) Turn the Flow Control valve until a trickle of clean water is flowing out the end of the Pickup Tube.
- 8) Turn the Percentage Knob back and forth to make sure all agent passages are flushed.
- 9) Shut off water and reinstall the Control Unit on the tank and insert the Pull Pins and circle cotters.
- 10) Remove the Cap.

The exterior of the DECON/pak can be washed off with the hose with the percentage knob in the RINSE position.

5.8 STORAGE

The DECON/pak can be stored with agent concentrate in it. Make sure the control block and valve assembly is mounted on the tank and the fill port is securely closed to prevent evaporation. Storage in the upright position is recommended to avoid agent leaking when the DECON/pak is not in use. (See figure 6.8)

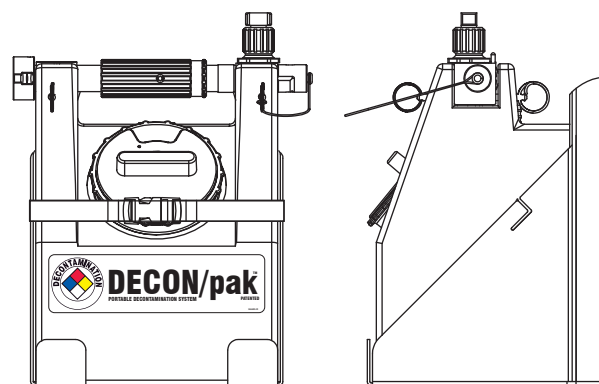

Figure 6.8
DECON/pak shown placed in a U-B mounting bracket in an upright position.

6.0 TROUBLE-SHOOTING

SYMPTOM	POSSIBLE CAUSE	REMEDY
DECON/pak will not make agent	Out Of Agent	Refill Tank
	Percentage Knob is in RINSE	Select desired percentage
	Percentage Knob is plugged	Remove screw on Percentage Knob, inspect and clean holes in top of control block and agent passages in bottom of Percentage Knob
	Non-standard outlet hose being used which is too long or too small in diameter	Order other hose option TFT part U-HS, U-HS6 or U-HS25
	Agent tank is nearly empty	Refill tank
Agent is Intermittent	DECON/pak tilted	Keep Twist Grip Horizontal
	Air vents are plugged	Make sure that the small black rubber valve on the inside of the agent tank lid is not stuck down with dried agent concentrate
Poor Quality Agent	Debris in nozzle	Inspect nozzle, look for plugged holes
	Debris under knob	Unscrew Knob, inspect and clean
	Agent solution velocity too high	Partially close Flow Control
	Agent gets thick when cold	Select Another Agent

7.0 CLEAN UP AND MAINTENANCE

Turn the percentage knob to the RINSE position. Use the hose, or hose and nozzle, to rinse off the DECON/pak. Reset percentage knob to proper percentage when finished.

For years of service, periodically inspect your DECON/pak. Make sure the hose and fan nozzle are in place. Look for debris in the bottom of the tank and flush if necessary.

7.1 DRAIN HOLE

If the DECON/pak is often used for different agent concentrates, it may be helpful to install a drain to aid in emptying the tank. Drill and tap the left front ear of the tank and install a ¼" NPT Pipe plug. Plastic or Brass preferred.

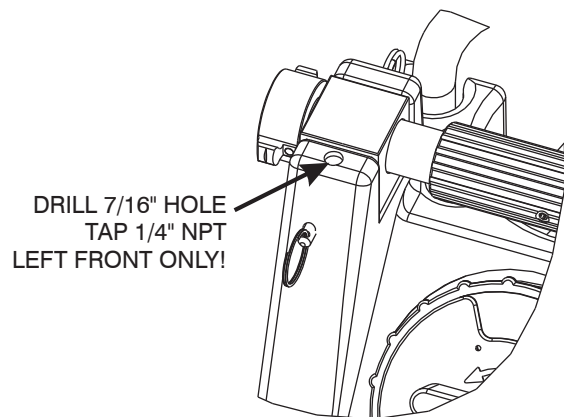

8.0 SPECIFICATIONS

	U.S. Units	Metric Units
Tank Capacity (to bottom of fill port)	2.5 U.S. gallons	9.5 liters
Nominal flow (all nozzles)	12 gpm at 100 psi	45 l/min at 6.8 bar
Weight Empty	11.5 lb	5.2 kg
Weight Full	30.1 lb	13.6 kg
Length x Width x Height	13.5 x 10.75 x 17 in	345 x 275 x 430 mm
Operating Pressure Max/Min	500/40 psi	34.5/3 bar

9.0 DRAWINGS & PARTS LIST

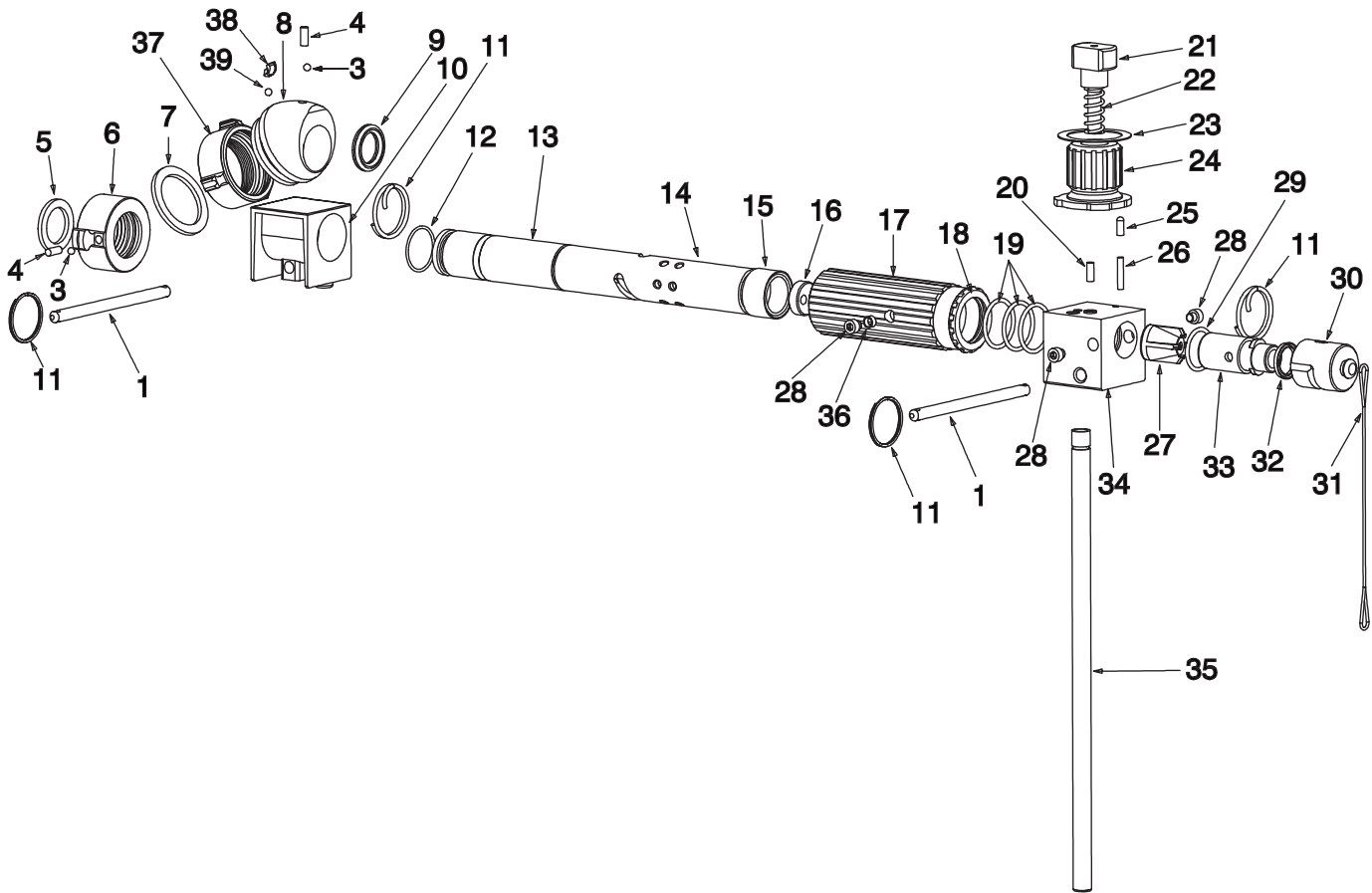

#	DESCRIPTION	QTY	PART #
1	Pull Pin	2	U180
3	3/16 SS Balls	21	V2120
4	1/4-28 x 1/2 Set Screw	1	VT25-28SS500
5	1.0 Hose Gasket	1	V3040
6	1.0 Coupling*	1	U260*
7	1.5 Hose Gasket	1	V3130
8	Angled Swivel	1	U265
9	Quad Seal	1	VOQ-4316
10	Rear Block	1	U270
11	Circle Cotter	4	U182
12	024 O-Ring	1	VO-024
13	Handle	1	U240
14	Flow Label	1	UL500
15	022 O-Ring	1	VO-022
16	Handle Plug	1	U241
17	Valve	1	U250
18	Valve Pointer Label	1	UL504
19	124 O-Ring	3	VO-124
20	1/4-20x3/4 Stud	1	U223

#	DESCRIPTION	QTY	PART #
21	Knob Nut	1	U221
22	Knob Spring	1	U222
23	Percent Knob Label - Decon	1	UL505-D
24	Percentage Knob - Decon	1	U232
25	Vinyl Cap	1	VM1030
26	Spirol Pin	1	V1900
27	Rear Venturi Insert	1	U214
28	Dog Point Screw	4	H515
29	120 O-Ring	1	VO-120
30	Venturi Cap	1	U213
31	Cable Assembly	1	VM1020
32	Cup Seal	1	U212
33	Front Venturi Insert	1	U210
34	Control Block	1	U200
35	Agent Pick Up Tube - Polyethylene	1	U201
36	Follower	2	U251
37	1.5 Coupling *	1	F10097*
38	Port Plug	1	B770
39	3/16 SS Balls	34	V2120

9.0 DRAWINGS & PARTS LIST (continued)

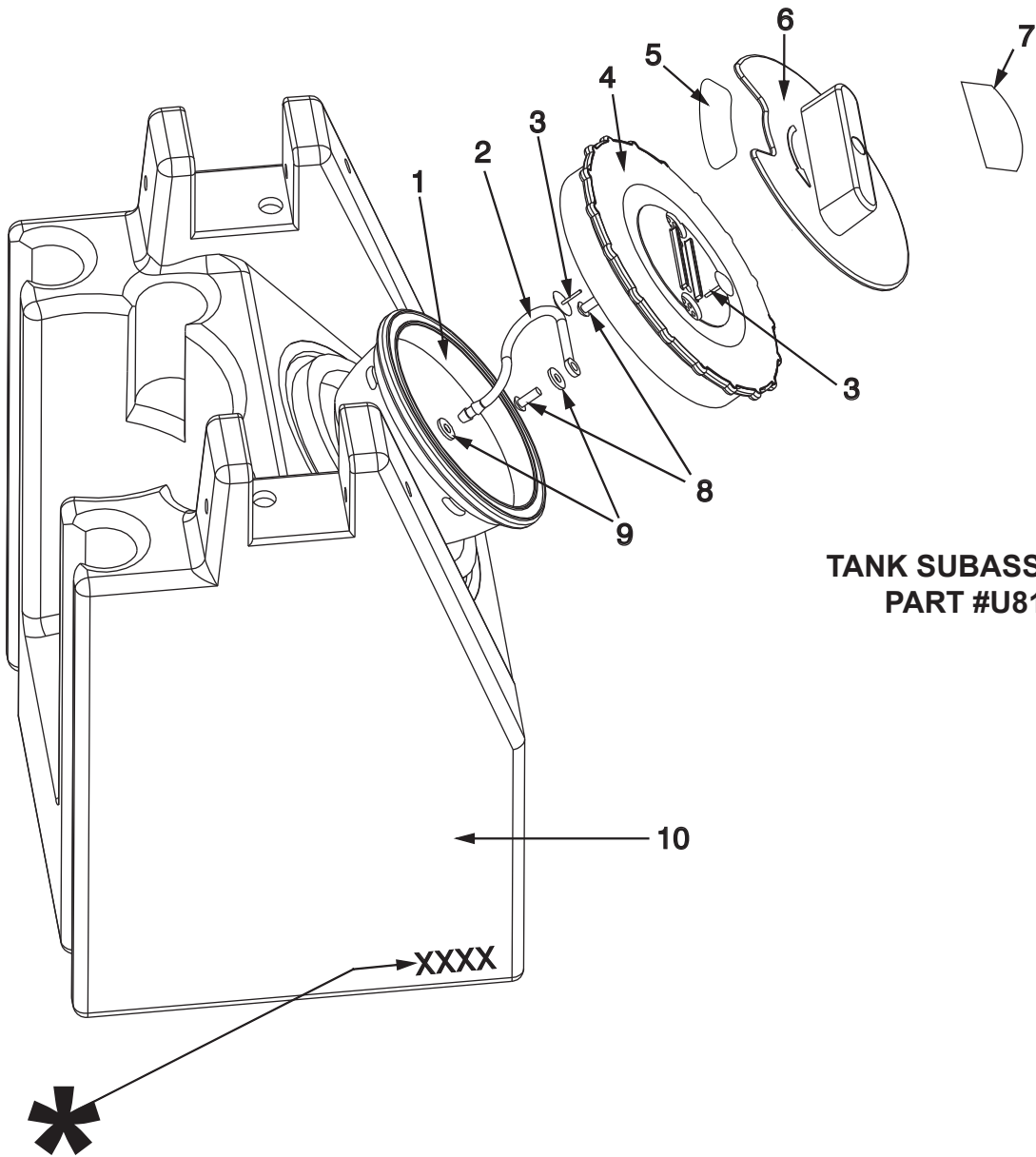

**TANK SUBASSEMBLY
PART #U810-D***

- UL503 TANK GRAPHIC-ENGLISH
- UL503-F TANK GRAPHIC-FRENCH
- UL503-G TANK GRAPHIC-GERMAN
- UL503-I TANK GRAPHIC-ITALIAN
- UL503-J TANK GRAPHIC-JAPANESE
- UL503-P TANK GRAPHIC-PORTUGUESE
- UL503-R TANK GRAPHIC-RUSSIAN
- UL503-S TANK GRAPHIC-SPANISH

#	DESCRIPTION	QTY	PART #
1	Filter Screen	1	U165
2	Filport Leash	1	U166
3	Valve Umbrella	2	VM4290
4	Screen On Lid	1	U170
5	Lid Label	1	UL506-D
6	Fill Port Handle	1	U161
7	Name Label	1	UL521-D
8	10-16 x 5/8 SS Screw	2	VT10-16PH625
9	SS Washers	3	VW500X203-60
10	Tank	1	U100-GREEN*

*Specify Language using identification number on tank graphic

10.0 WARRANTY

Task Force Tips, Inc., 3701 Innovation Way, Valparaiso, Indiana 46383-9327 USA ("TFT") warrants to the original purchaser of its nozzles and other equipment ("equipment"), and to anyone to whom it is transferred, that the equipment shall be free from defects in material and workmanship during the five (5) year period from the date of purchase.

TFT's obligation under this warranty is specifically limited to replacing or repairing the equipment (or its parts) which are shown by TFT's examination to be in a defective condition attributable to TFT. To qualify for this limited warranty, the claimant must return the equipment to TFT, at 3701 Innovation Way, Valparaiso, Indiana 46383-9327 USA, within a reasonable time after discovery of the defect. TFT will examine the equipment. If TFT determines that there is a defect attributable to it, it will correct the problem within a reasonable time. If the equipment is covered by this limited warranty, TFT will assume the expenses of repair.

If any defect attributable to TFT under this limited warranty cannot be reasonably cured by repair or replacement, TFT may elect to refund the purchase price of the equipment, less reasonable depreciation, in complete discharge of its obligations under this limited warranty. If TFT makes this election, claimant shall return the equipment to TFT free and clear of any liens and encumbrances.

This is a limited warranty. The original purchaser of the equipment, any person to whom it is transferred, and any person who is an intended or unintended beneficiary of the equipment, shall not be entitled to recover from TFT any consequential or incidental damages for injury to person and/or property resulting from any defective equipment manufactured or assembled by TFT. It is agreed and understood that the price stated for the equipment is in part consideration for limiting TFT's liability. Some states or countries do not allow the exclusion or limitation of incidental or consequential damages, so the above may not apply to you.

TFT shall have no obligation under this limited warranty if the equipment is, or has been, misused or neglected (including failure to provide reasonable maintenance) or if there have been accidents to the equipment or if it has been repaired or altered by someone else.

THIS IS A LIMITED EXPRESS WARRANTY ONLY. TFT EXPRESSLY DISCLAIMS WITH RESPECT TO THE EQUIPMENT ALL IMPLIED WARRANTIES OF MERCHANTABILITY AND ALL IMPLIED WARRANTIES OF FITNESS FOR A PARTICULAR PURPOSE. THERE IS NO WARRANTY OF ANY NATURE MADE BY TFT BEYOND THAT STATED IN THE DOCUMENT.

This limited warranty gives you specific legal rights, and you may also have other rights which vary from state to state.