

INSTRUCTIONS FOR SAFE OPERATION AND MAINTENANCE

⚠ WARNING

Understand manual before use. Operation of this device without understanding the manual and receiving proper training is a misuse of this equipment. Obtain safety information at www.tft.com/serial-number

This instruction manual is intended to familiarize firefighters and maintenance personnel with the operation, servicing and safety procedures associated with the Metro 0, 1 & 2 fire fighting nozzles.

This manual should be kept available to all operating and maintenance personnel.

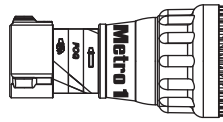

ME1-TO
Tip Only

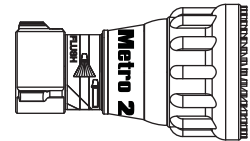

ME2-TO
Tip Only

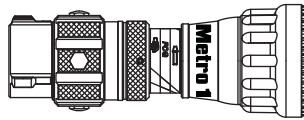

ME1-STO
Twist Valve

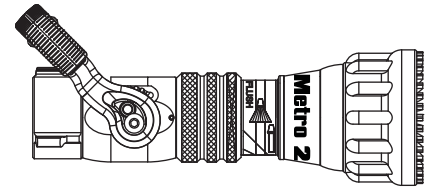

ME2-V with Bail
Valve Handle

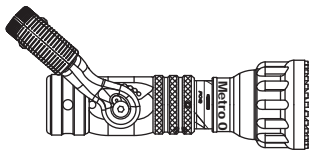

ME0-V with Bail
Valve Handle

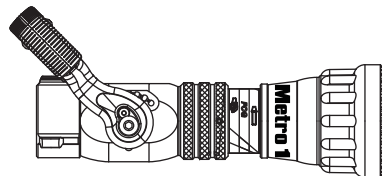

ME1-V with Bail
Valve Handle

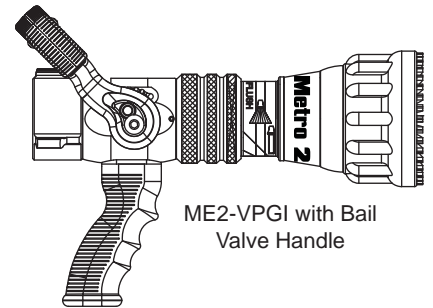

ME2-VPGI with Bail
Valve Handle

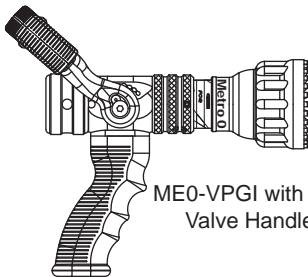

ME0-VPGI with Bail
Valve Handle

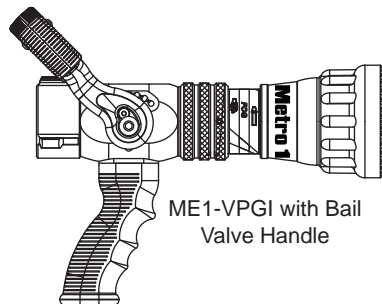

ME1-VPGI with Bail
Valve Handle

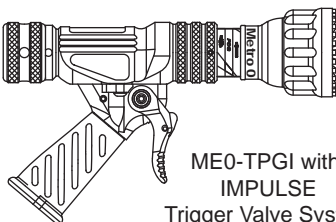

ME0-TPGI with
IMPULSE
Trigger Valve System

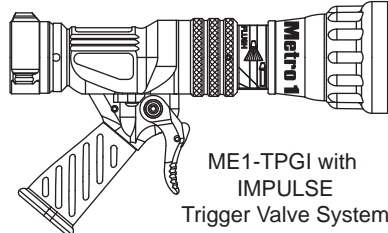

ME1-TPGI with
IMPULSE
Trigger Valve System

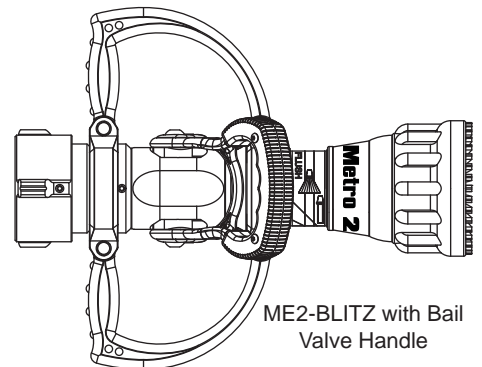

ME2-BLITZ with Bail
Valve Handle



PERSONAL RESPONSIBILITY CODE

The member companies of FEMSA that provide emergency response equipment and services want responders to know and understand the following:

1. Firefighting and Emergency Response are inherently dangerous activities requiring proper training in their hazards and the use of extreme caution at all times.
2. It is your responsibility to read and understand any user's instructions, including purpose and limitations, provided with any piece of equipment you may be called upon to use.
3. It is your responsibility to know that you have been properly trained in Firefighting and /or Emergency Response and in the use, precautions, and care of any equipment you may be called upon to use.
4. It is your responsibility to be in proper physical condition and to maintain the personal skill level required to operate any equipment you may be called upon to use.
5. It is your responsibility to know that your equipment is in operable condition and has been maintained in accordance with the manufacturer's instructions.
6. Failure to follow these guidelines may result in death, burns or other severe injury.



Fire and Emergency Manufacturers and Service Association
P.O. Box 147, Lynnfield, MA 01940 • www.FEMSA.org

Table Of Contents

1.0 MEANING OF SAFETY SIGNAL WORDS	6.0 USE WITH FOAM
2.0 SAFETY	6.1 FOAM ASPIRATING ATTACHMENTS
3.0 GENERAL INFORMATION	7.0 USE OF NOZZLES
3.1 VARIOUS MODELS AND TERMS	8.0 APPROVALS
3.2 SPECIFICATIONS	9.0 COLOR CODED VALVE HANDLE AND PISTOL GRIP
3.2.1 MECHANICAL	9.1 IMPULSE TRIGGER VALVE SYSTEM
3.3 NOZZLE COUPLINGS	COLORED PISTOL GRIPS
3.4 USE WITH SALT WATER	10.0 DRAWINGS AND PART LISTS
4.0 FLOW CHARACTERISTICS	10.1 METRO 0
4.1 METRO 0	10.2 METRO 1
4.2 METRO 1	10.3 METRO 2
4.3 METRO 2	10.4 IMPULSE TRIGGER VALVE
4.4 FLOW SETTING	10.5 IMPULSE GRIP
5.0 NOZZLE CONTROLS	11.0 WARRANTY
5.1 FLOW CONTROL	12.0 MAINTENANCE
5.1.1 LEVER TYPE FLOW CONTROL	12.1 FIELD LUBRICATION
5.1.2 TIP ONLY NOZZLES	12.2 IMPULSE TRIGGER VALVE
5.1.3 BALL SHUTOFF	LUBRICATION
5.1.4 TWIST SHUTOFF	12.3 SERVICE TESTING
5.1.5 IMPULSE TRIGGER FLOW CONTROL	12.3.1 HYDROSTATIC TESTING
5.1.5.1 IMPULSE TRIGGER LOCK	12.3.2 FLOW TESTING
5.1.5.2 TRIGGER FLOW CONTROL SPEED	12.3.3 RECORDS
ADJUSTMENT	12.4 REPAIR
5.2 PATTERN AND FLUSH CONTROL	13.0 OPERATION and INSPECTION CHECKLIST
5.2.1 PATTERN CONTROL	
5.2.2 FLUSH CONTROL	

1.0 MEANING OF SAFETY SIGNAL WORDS

A safety related message is identified by a safety alert symbol and a signal word to indicate the level of risk involved with a particular hazard. Per ANSI standard Z535.6-2011, the definitions of the four signal words are as follows:

 **DANGER** indicates a hazardous situation which, if not avoided, will result in death or serious injury.

 **WARNING** indicates a hazardous situation which, if not avoided, could result in death or serious injury.

 **CAUTION** indicates a potentially hazardous situation which, if not avoided, could result in minor or moderate injury.

 **NOTICE** is used to address practices not related to personal injury.

SAFETY INSTRUCTIONS (or equivalent) signs indicate specific safety-related instructions of procedures.

2.0 SAFETY

 **DANGER** An inadequate supply of nozzle pressure and/or flow will cause an ineffective stream and can result in injury, death, or loss of property. See flow graphs or call 800-348-2686 for assistance.

 **WARNING** The nozzle may be damaged if frozen while containing significant amounts of water. Such damage may be difficult to detect visually and can lead to possible injury or death. Any time the nozzle is subject to possible damage due to freezing, it must be tested by qualified personnel before being considered safe for use.

 **WARNING** This equipment is intended for use by trained personnel for firefighting. Their use for other purposes may involve hazards not addressed by this manual. Seek appropriate guidance and training to reduce risk of injury.

 **WARNING** Failure to restrain nozzle reaction can cause firefighter injury from loss of footing and/or stream protection. Nozzle reaction will vary as supply conditions change: such as opening or closing other nozzles, hose line kinks, changes in pump settings, etc. Changes in spray pattern or flushing will also affect nozzle reaction. The nozzle operator must always be prepared in the event of these changes.

 **WARNING** If nozzle gets out of control or away from operator, retreat from nozzle immediately. Do not attempt to regain control of nozzle while flowing water. Injury from whipping can occur.

 **WARNING** Water is a conductor of electricity. Application of water on high voltage equipment can cause injury or death by electrocution. The amount of current that may be carried back to the nozzle will depend on the following factors:

- Voltage of the line or equipment
- Distance from the nozzle to the line or equipment
- Size of the stream
- Whether the stream is solid or broken
- Purity of the water¹

¹ The Fire Fighter and Electrical Equipment, The University of Michigan Extension Service, Fourth Printing 1983. Page 47.

 **CAUTION** Fire streams are capable of injury and damage. Do not direct water stream to cause injury or damage to persons or property.

3.0 GENERAL INFORMATION

The Task Force Tips nozzles are designed to provide excellent performance under most firefighting conditions. Their rugged construction is compatible with the use of fresh water as well as firefighting foam solutions.

SERIES	RECOMMENDED MIN HOSE DIA.	FLOW SETTINGS	NOZZLE TYPE
METRO 0 (small body)	3/4" 19 mm	Field Changeable To Any of 7 Sizes	Fixed Flow
METRO 1 (small body)	1-1/2 38 mm	Field Changeable To Any of 14 Sizes	Fixed Flow
METRO 2 (large body)	1-1/2 to 2-1/2 38 mm	Field Changeable To Any of 10 Sizes	Fixed Flow

The nozzle is available in several different models and inlet connections. Basic body styles are shown in figure 3.1
Other important operating features include:

- Interchangeable washer to allow for user defined flow and pressure
- Quick-acting pattern control from straight stream to wide fog
- “Power fog teeth” for full-fill fog or Spinning Teeth on Metro 1 Series
- Easily flushable while flowing to clear trapped debris

3.1 VARIOUS MODELS AND TERMS

Fixed Flow: A nozzle with a discharge orifice that is a fixed opening size

Tip Only: a nozzle without an integral ball shutoff valve. A Metro tip only nozzle is available in a variety of flow ranges and configurations. All models deliver the rated flow when the rated pressure is supplied to the nozzle.

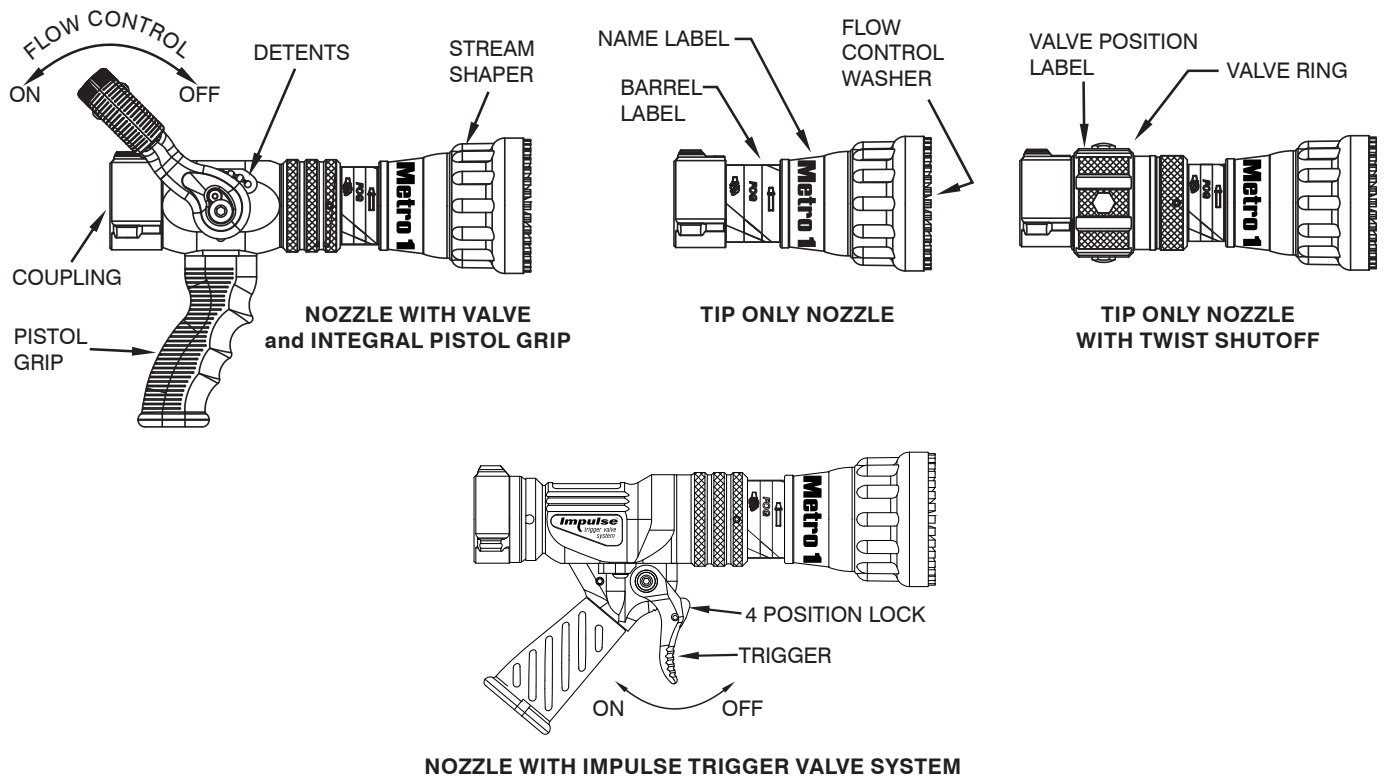

Figure 3.1
Common Model and Terms

3.2 SPECIFICATIONS

3.2.1 MECHANICAL

Maximum nozzle inlet pressure with valve shutoff	Metro 0 - 580 psi	40 bar
	Metro 1 - 300 psi	21 bar
	Metro 2 - 300 psi	21 bar
Operating temperature range of fluid	33 to 120° F	1 to 50° C
Storage temperature range	-40 to 150° F	-40 to 65° C
Materials used	Aluminum 6000 series hard anodized MIL8625 class 3 type 2, stainless steel 300 series, nylon 6-6, nitrile rubber	

3.3 NOZZLE COUPLING

Many inlet couplings such as NH (National Hose) or NPSH (National Pipe Straight Hose) can be specified at time of order.

CAUTION

Nozzle must be mated to a hose line with matched threads. Mismatched or damaged threads may cause nozzle to leak or uncouple under pressure and could cause injury.

CAUTION

Dissimilar metals coupled together can cause galvanic corrosion that can result in the inability to unscrew the threads or complete loss of thread engagement over time. Per NFPA 1962, if dissimilar metals are left coupled together an anti-corrosive lubricant should be applied to the threads. Also the coupling should be disconnected and inspected at least quarterly.

3.4 USE WITH SALT WATER

Use with saltwater is permissible provided nozzle is thoroughly cleaned with fresh water after each use. The service life of the nozzle may be shortened due to the effects of corrosion and is not covered under warranty.

4.0 FLOW CHARACTERISTICS

The opening size of the METRO nozzles may be field set to any one of the several different sizes. At each flow setting the nozzle is set to a predetermined fixed orifice. Relationship of flow and nozzle pressure at each setting is shown below.

SPECIAL CONFIGURATIONS If nozzles are made according to the special marking or performance requirements of the fire department then the operating characteristics may differ from the published data in this manual. Repair parts specific to each serial number may differ from those shown in the service procedure. The required parts for each serial number are available on-line by entering www.tft.123456 with the numbers corresponding to the serial number engraved on the product.

4.1 METRO 0

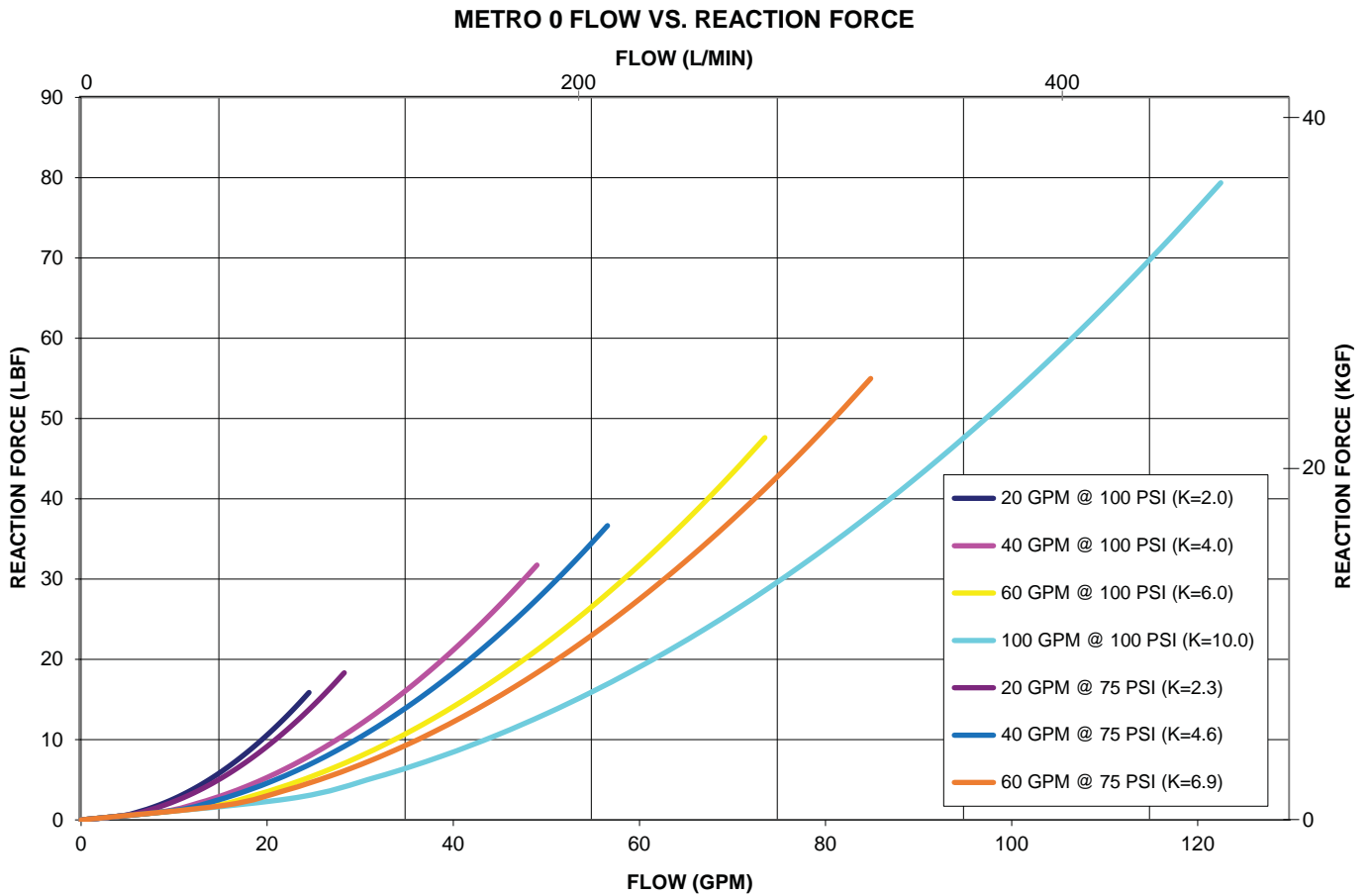
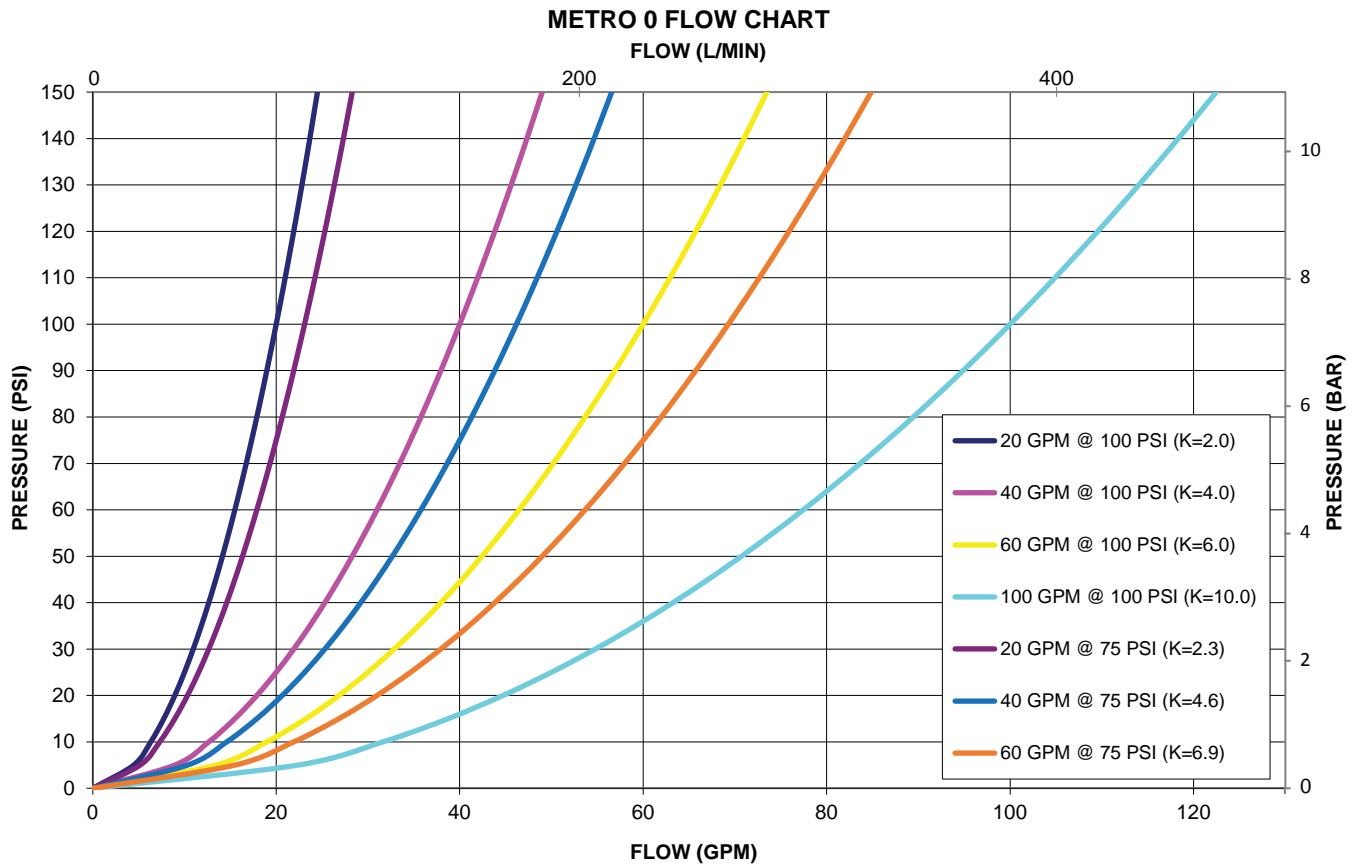

4.2 METRO 1

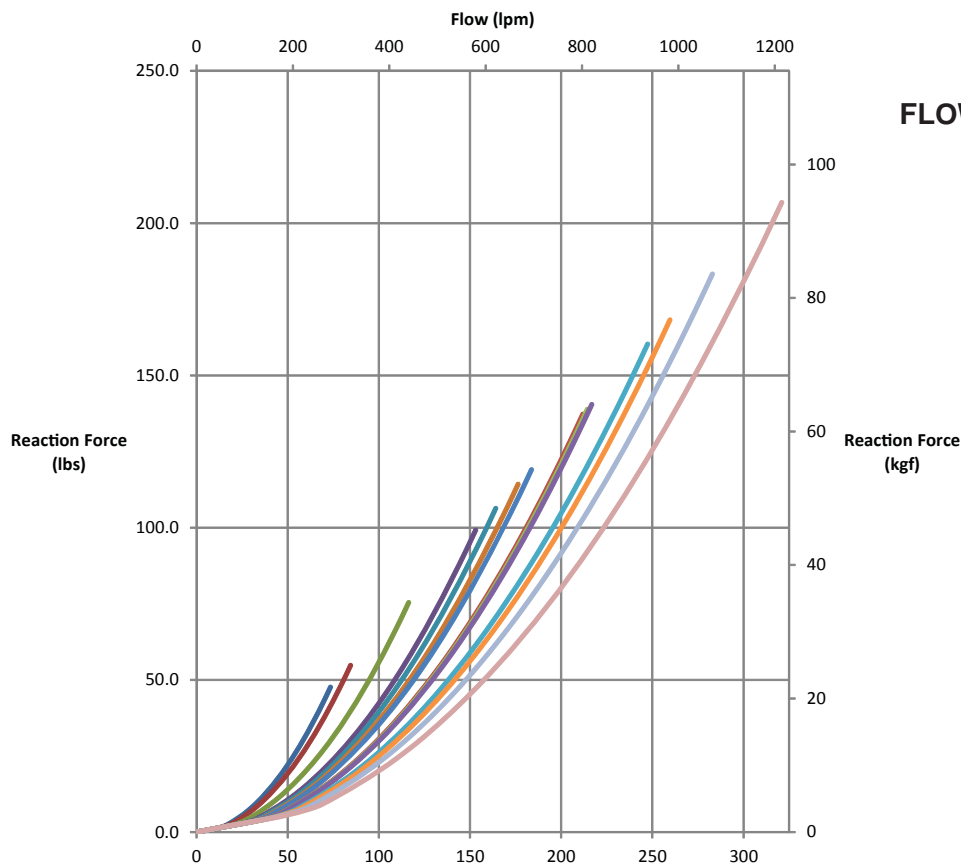
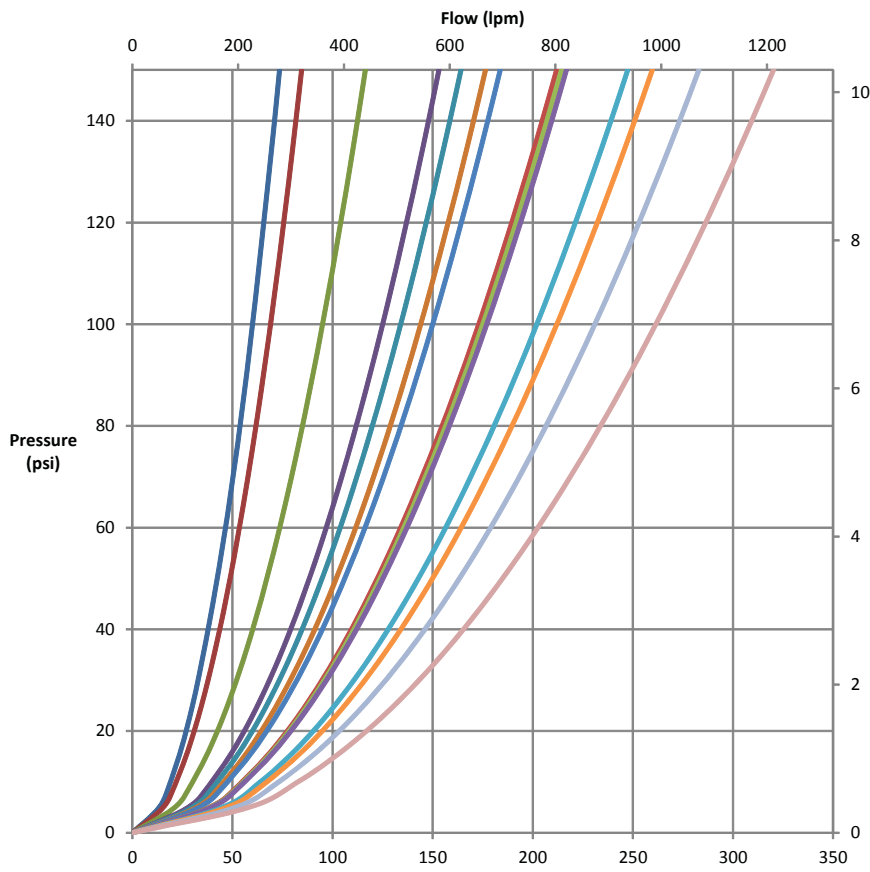

4.3 METRO 2

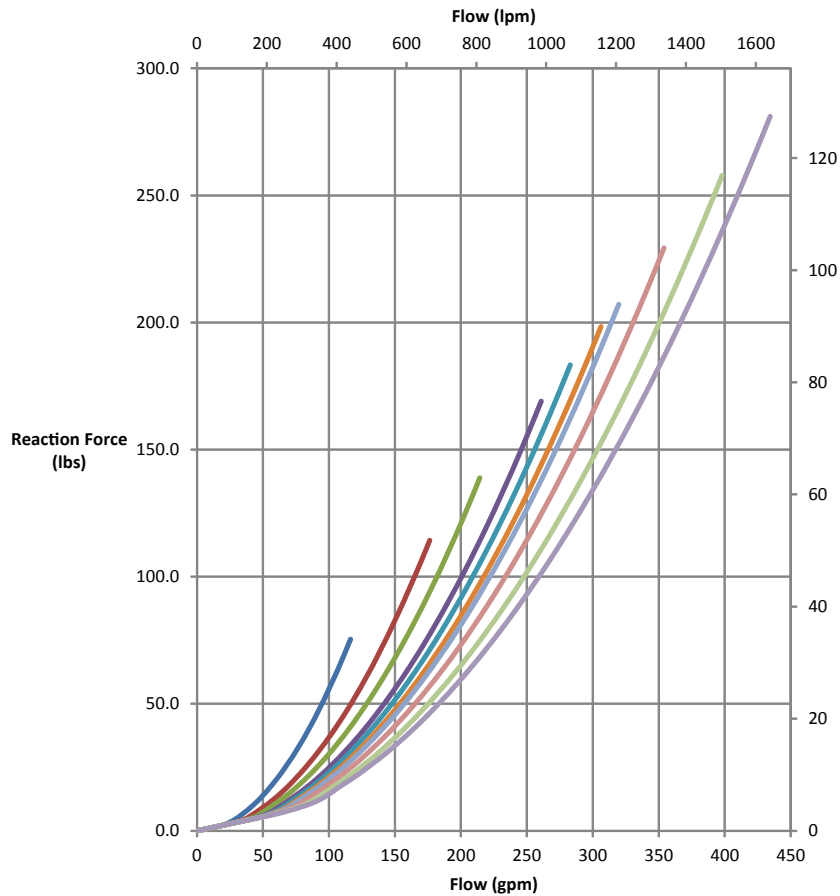
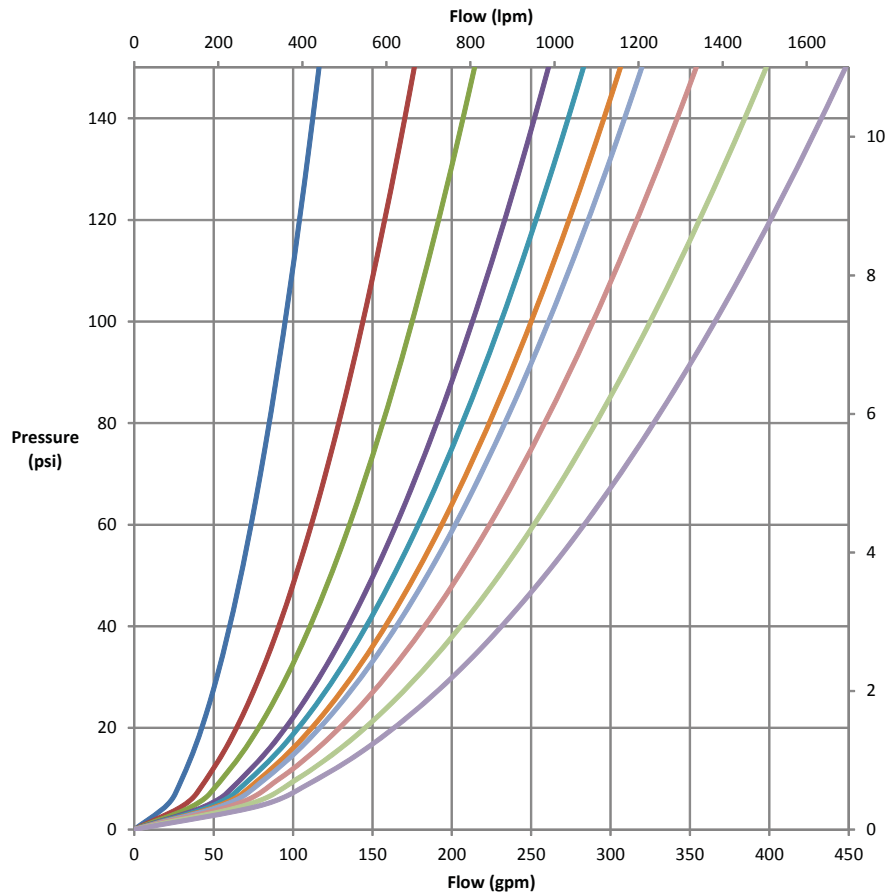

4.4 FLOW SETTING

The washers are marked with various flow settings. Change washer to the desired setting. **The nozzle will flow the indicated amount when the pressure at the nozzle is at the indicated level.**

To change flow and pressure setting of the Metro, use the following instructions:

- 1) Set nozzle into FLUSH.
- 2) Push baffle down to barrel cone.
- 3) Remove screw and washer using a 5/32 hex key.
- 4) Remove pre-set flow washer and slide desired flow washer onto shaft, desired flow marking facing up.
- 5) Thread screw with washer back into shaft until snug (Do not over tighten).

NOTE: Metro 0, 1 and 2 series flow washers are not interchangeable

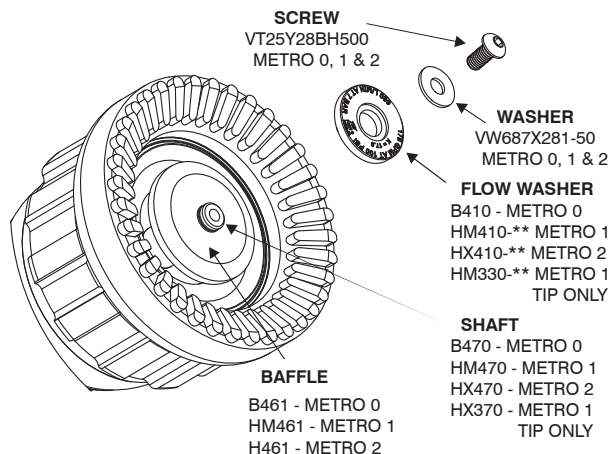

WARNING Failure to secure screw and washer will result in the baffle becoming loose. This will produce poor stream, improper flows and possible discharge of the complete baffle, resulting in risk of injury.

5.0 NOZZLE CONTROLS

Nozzle control valves must be opened slowly to eliminate unnecessary strain on the hose and couplings and reduce pressure surges.

5.1 FLOW CONTROL

5.1.1 LEVER TYPE FLOW CONTROL

On models that use a lever type valve handle, the nozzle is shut off when the handle is fully forward. The valve handle has detented flow positions. These detent positions allow the nozzle operator to regulate the flow of the nozzle depending on the need or what can be safely and effectively handled. TFT recommends the use of a pistol grip for easier handling. For additional stress reduction, a hose rope or strap may also be used. This permits more effective use and ease of advancement, while minimizing strain and fatigue.

Nozzles attached to an in-service hose shall be stored in the off position.

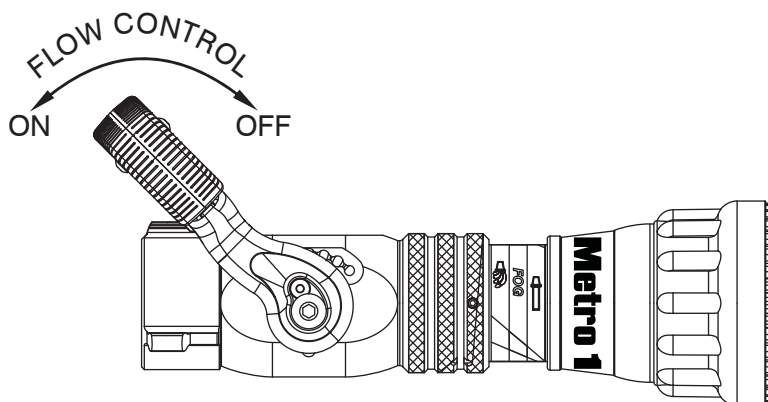

5.1.2 TIP ONLY NOZZLES

Tip only nozzles have NO shut-off valve within the nozzle and MUST be used with a separate ball valve attached to the nozzle. Using a nozzle without a shutoff is an unsafe practice and should never be done.

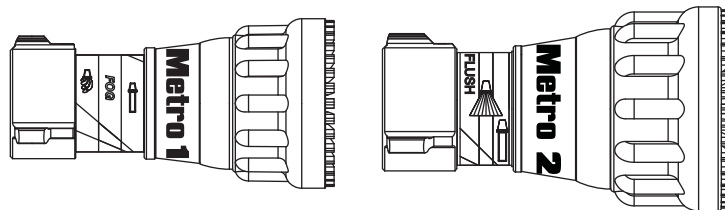

5.1.3 BALL VALVE SHUTOFF

A separate ball valve for use with Tip Only nozzles is shut off when the valve handle is fully forward. Pulling back on the handle opens the valve. Open valve slowly to avoid sudden changes in nozzle reaction. Close valve slowly to prevent water hammer. Note: In partially open positions a ball valve will cause turbulence and adversely affect stream quality.

Nozzles attached to an in-service hose shall be stored in the off position.

The notch in the ball is designed to reduce turbulence through a partially opened valve and does not affect shutoff.

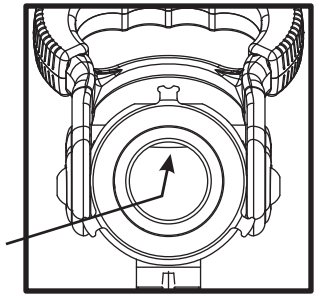

5.1.4 TWIST SHUTOFF

On models that use a twist flow control, the valve is opened or closed by rotating the valve ring. Rotating the ring clockwise (as seen from the operating position behind the nozzle) closes the valve, while counterclockwise rotation opens it. Detents are provided at four intermediate positions and the position of the valve is shown by the exposed valve position label.

Nozzles attached to an in-service hose shall be stored in the off position.

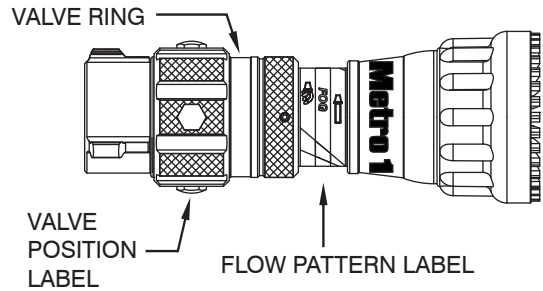

5.1.5 IMPULSE TRIGGER FLOW CONTROL

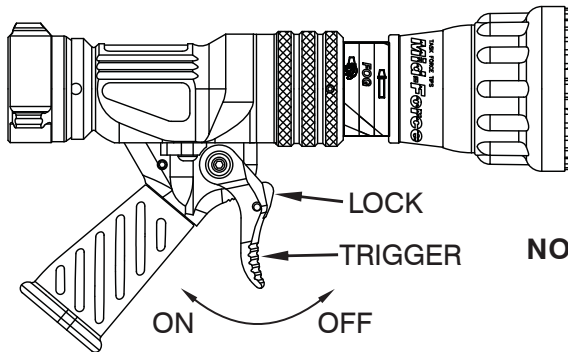

NOTE: THE TRIGGER RETURNS TO OFF IF NOT HELD OR LOCKED



WARNING Do not intentionally release the nozzle while flowing and trust the valve to shut off automatically. The trigger nozzle's ability to shut off by itself represents an extra level of safety when following normal nozzle handling procedures. To rely on it as the sole means of safety increases the risk of injury from an out of control nozzle. Release nozzle when flow has stopped.

5.1.5.1 IMPULSE TRIGGER LOCK

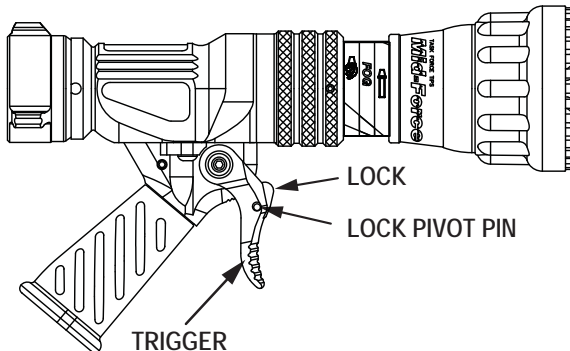

To Lock: Push on the lock while pulling back the trigger to engage one of the four locked positions.

To Release: Pull back slightly on trigger without any pressure on the lock. The spring loaded lock should automatically move to the unlocked position.

Use an 1/8" (3mm) punch to push out pin and remove lock if the lock is not desired.



WARNING When the trigger lock is engaged, the nozzle will not shut off if dropped. Always shut off nozzle before releasing the pistol grip to avoid injury from an out of control nozzle.

5.1.5.2 TRIGGER FLOW CONTROL SPEED ADJUSTMENT

The IMPULSE valve contains a slow close mechanism to prevent the nozzle from slamming off if the trigger is suddenly released. The closing speed is set at the factory to be slow enough to reduce water hammer, (“water hammer” is always present in any valve when it is shut off. The slow close mechanism will reduce this but cannot eliminate it completely) but fast enough to reduce the potential danger of hose whipping from a dropped nozzle. The closing speed may be adjusted as shown in the figure.5.1.5.2.

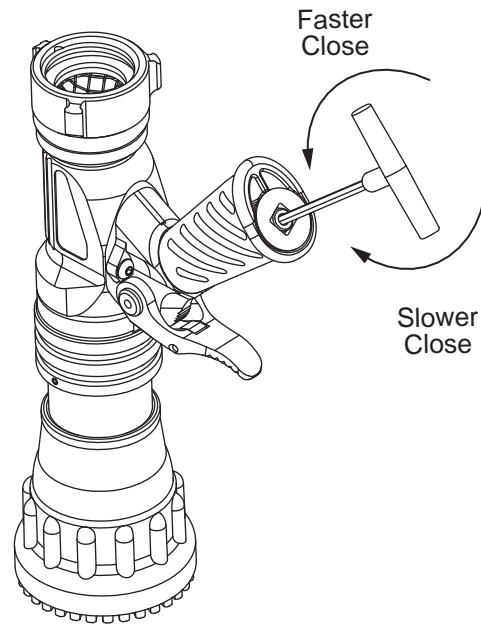

Figure 5.1.5.2

Do not unscrew the adjuster past the end of the hand grip (to unscrew it too far could result in the loss of dampening fluid.)

WARNING A flowing nozzle can cause injury within the first second of lost control. As the closing time is increased so does the risk of injury from an out of control nozzle. Use caution when adjusting the closing speed and always verify performance after adjustment.

5.2 PATTERN AND FLUSH CONTROL

5.2.1 PATTERN CONTROL

TFT’s nozzles have full pattern control from straight stream to wide fog. Turning the stream shaper clockwise (as seen from the operating position behind the nozzle) moves the shaper to the straight stream position. Turning the shaper counterclockwise will result in an increasingly wider pattern.

Since the stream trim point varies with flow, the stream should be “trimmed” after changing the flow to obtain the straightest and farthest reaching stream. To properly trim the stream, first open the pattern to narrow fog. Then close the stream to parallel to give maximum reach. **Note: Turning the shaper further forward will cause stream crossover and reduce the effective reach of the nozzle.**

The nozzle reaction is greatest when the shaper is in the straight stream position. The nozzle operator must be prepared for a change in reaction as the pattern is changed.

5.2.2 FLUSH CONTROL

Small debris passes through the debris screen (if equipped) and may get caught inside the nozzle. This trapped material will cause poor stream quality, shortened reach, and reduced flow. To remove small debris, the nozzle may be flushed as follows:

- While still flowing water, rotate the SHAPER counterclockwise (as viewed from behind the nozzle) to the flush position. (increased resistance will be felt on the SHAPER or RING as the nozzle goes into flush) This will open the nozzle allowing debris to pass through.
- During flush the nozzle reaction will decrease as the pattern becomes wider and the pressure drops. The nozzle operator must be prepared for an increase of nozzle reaction when returning the nozzle from the flush position to retain control of the nozzle.
- Rotate the SHAPER out of flush to continue normal operations.

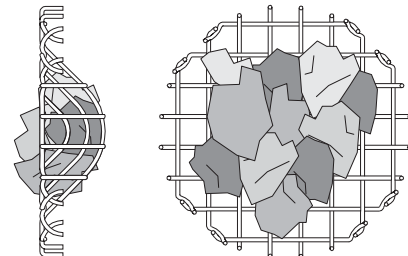

WARNING Large amounts or pieces of debris may be unflushable and can reduce the flow of the nozzle resulting in an ineffective flow. In the event of a blockage, it may be necessary to retreat to a safe area, uncouple the nozzle and remove debris.

6.0 USE WITH FOAM

The nozzle may be used with foam solutions. Refer to fire service training for the proper use of foam.

⚠ WARNING For Class B fires, lack of foam or interruption in the foam stream can cause a break in the foam blanket and greatly increase the risk of injury or death.

Assure that:

- Application rate is sufficient (see NFPA 11 or foam manufacturer's recommendations)
- Enough concentrate is on hand to complete task (see NFPA for minimum duration time requirements)
- Foam logistics have been carefully planned.

Allow for such things as:

- Storage of foam in a location not exposed to the hazard it protects
- Personnel, equipment and technique to deliver foam at a rapid enough rate
- Removal of empty foam containers
- Clear path to deliver foam, as hoses and other equipment and vehicles are deployed

⚠ WARNING Improper use of foam can result in injury or damage to the environment. Follow foam manufacturer's instructions and fire service training to avoid:

- Using wrong type of foam on a fire, i.e. Class A foam on a Class B fire
- Plunging foam into pools of burning liquid fuels
- Causing environmental damage
- Directing stream at personnel

⚠ WARNING There are a wide variety of foam concentrates. Each user is responsible for verifying that any foam concentrate chosen to be used with this unit has been tested to assure that the foam obtained is suitable for the purpose intended.

⚠ WARNING Use of compressed air foam (CAF) with hand held nozzles can cause sudden surges in nozzle reaction force resulting in risk of injury or death from loss of footing or hose whipping. Be prepared for sudden changes in nozzle reaction caused by:

- Slug loading (Loss of foam concentrate sends slugs of air and water into the nozzle)
- Sudden release of built-up pressure in the hose when opening a nozzle

6.1 FOAM ASPIRATING ATTACHMENTS

Multi-expansion or low expansion aspirating attachments may be used with nozzles to increase the expansion ratio. These foam tubes attach and detach quickly from the nozzle. As expansion ratio is increased, the reach of the nozzle will be decreased due to the greater amount of bubbles in the stream and their ability to penetrate the air. Generally the straight stream reach with foam is approximately 10% less than with water only. Actual results will vary based on brand of foam, hardness of water, temperature, etc. For specific information, see LIA-025 (MANUAL: Foam Attachments for TFT Nozzles).

7.0 USE OF NOZZLES

Many factors contribute to the extinguishment of a fire. Among the most important is delivering water at a flow rate sufficient to absorb heat faster than it is being generated. The flow rate depends largely on the pump discharge pressure and hose friction loss. It can be calculated using a hydraulic equation such as:

$$PDP = NP + FL + DL + EL$$

PDP = Pump discharge pressure in PSI

NP = Nozzle pressure in PSI

FL = Hose friction loss in PSI

DL = Device loss in PSI

EL = Elevation loss in PSI

This manual is not intended to act as a training guide for safe fireground tactics and operations. For additional information visit www/tft.com or contact customer service at 800-348-2686.

8.0 APPROVALS

Many nozzle configurations carry the FM Approval rating, NFPA certification, or EN certification.

9.0 COLOR CODED VALVE HANDLE AND PISTOL GRIP

The TFT nozzle with lever type valve handles are supplied with black valve handle covers and pistol grips. The handle covers and pistol grips are available from TFT in various colors for those departments wishing to color code the nozzle to the discharge controls. A colored handle cover set will be sent upon receipt of the warranty card by TFT. Your department's name can also be engraved on the covers (see warranty card for more information).

Handle covers are replaceable by removing the four screws that hold the handle covers in place. Use a 3/32" Allen wrench when replacing screws. Pistol grip is replaceable by following TFT instruction sheet LTT-108 for standard grips or LTT-115 for Trigger Controlled Valves.

For standardization NFPA 1901 (A-4-9.3) recommends the following color code scheme:

Preconnect #1 or Bumper Jump Line	Orange	Other Colors Available:
Preconnect or discharge #2	Red	• Gray
Preconnect or discharge #3	Yellow	• Pink
Preconnect or discharge #4	White	• Purple
Preconnect or discharge #5	Blue	• Tan
Preconnect or discharge #6	Black	
Preconnect or discharge #7	Green	
Foam Lines	Red w/ White border (Red/White)	

9.1 IMPULSE TRIGGER VALVE SYSTEM NOZZLE COLORED PISTOL GRIPS

The TFT Impulse Trigger Valve System nozzles are supplied with black pistol grip covers. The pistol grip covers are available from TFT in various colors for those departments wishing to color code the nozzle to the discharge controls. Follow the steps below to change the pistol grip cover.

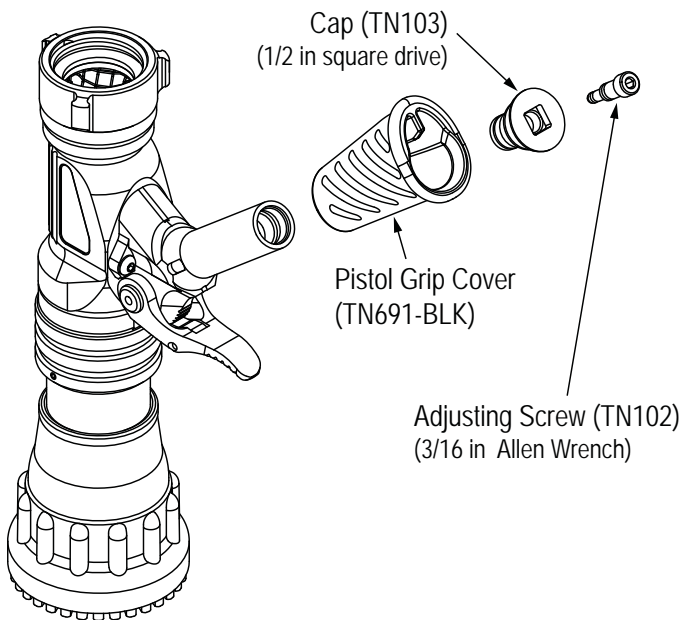

- 1) Orient nozzle vertically. This keeps the dampening fluid in the pistol grip from spilling out.
- 2) Remove the Cap. (1/2 in square drive) The Adjusting Screw (3/16 in Allen Wrench) may need to be turned in or removed to be able to engage the square pocket in the cap. Note the position of the Adjusting Screw before moving it.
- 3) Slide off the Pistol Grip Cover and install a new one. Be sure the Pistol Grip Cover's internal rib is toward the back of the nozzle.
- 4) Reinstall the Cap until it bottoms out on its shoulder.
- 5) Reinstall or reposition the Adjusting Screw if it has been moved from its original location.
- 6) Flow nozzle to check performance of slow closer. Adjust as needed (see section 5.1.5.2).

10.0 DRAWINGS AND PARTS LIST

10.1 METRO 0

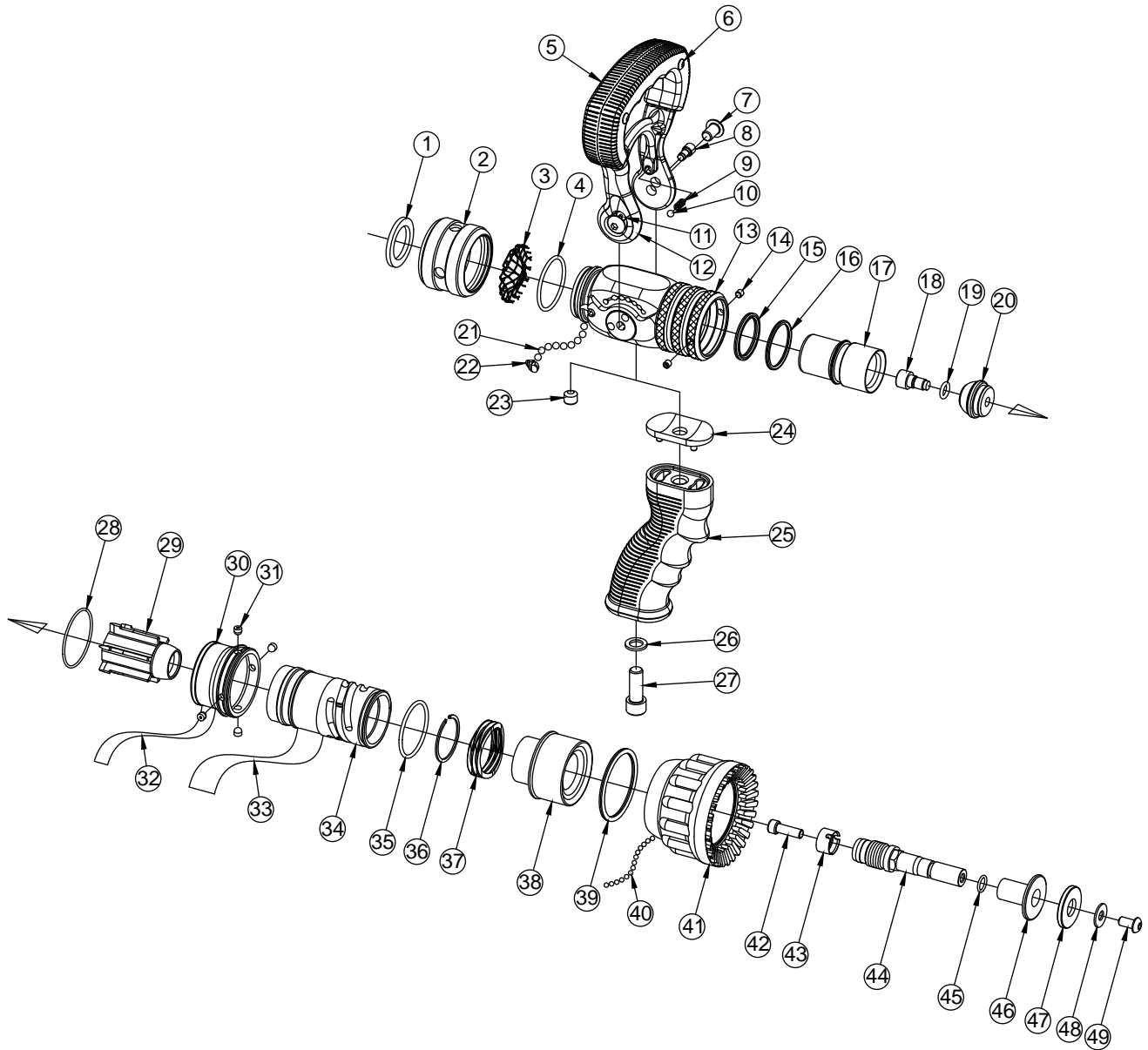

METRO 0 - V and VPGI

#	DESCRIPTION	QTY	PART #
1	GASKET - 1.0"	1	V3040
2	COUPLING 1.0"F	1	B680*
3	1.0" GASKET GRABBER	1	B730
4	O-RING-127	1	VO-127
5	BLACK HANDLE COVER	2	HM625-BLK
6	8-14 X 3/8 PUSH TITE BUTTON HEAD	4	VT08-14PT375
7	5/16-18 X 1/2 BUTTON HEAD SCREW	2	VT31E18BH500
8	SAFETY PIN	1	B635
9	DETENT SPRING	2	VM4195
10	3/16" TORLON BALL	2	V2120-TORLON
11	CAM PIN	1	B630
12	HANDLE	1	B622
13	VALVE BODY	1	B600
	VALVE DISK	2	B640
	DRAG NUB	4	B650
	SMALLEY RING	2	V4260
14	10-32 X 3/16 SOCKET SET SCREW	2	VT10-32SS187
15	QUAD-RING-216	1	VOQ-4216
16	QUAD-RING-214	1	VOQ-4124
17	SLIDER	1	B660
18	I/O SCREW	1	B595
19	O-RING-109	1	VO-109
20	VALVE PLUG	1	B590
21	3/16" SS BALL	28	V2120
22	PORT PLUG	1	B770
23	3/8-16 X 5/16 SOCKET SET SCREW	1	VT37-16SS312
24	GRIP SPACER - ULTIMATIC	1	HM693-U
25	PISTOL GRIP	1	HM692-BLK

#	DESCRIPTION	QTY	PART #
26	WASHER	1	VM4901
27	3/8-16 X 1 SOCKET HEAD SCREW	1	VT37-16SH1.0
28	O-RING-030	1	VO-030
29	FIN CAN	1	B480
30	SHAPER GUIDE	1	B510
31	SHAPER BULLETS	4	B501
32	NAME LABEL: METRO 0	1	B740-ORG
33	BARREL LABEL - ORANGE	1	B745-ORG
34	BARREL	1	B540
35	O-RING-128	1	VO-128
36	SNAP RING	1	V4270
37	FLUSH WAVE SPRING	1	B785
38	BARREL CONE	1	B525
39	QUAD-RING-225	1	VOQ-4225
40	1/8" NYLON BALL	46	V2135
41	SHAPER WITH BUMPER	1	B500
42	1/4-28 X 3/4 SOCKET HEAD SCREW	1	VT25-28SH750
43	LOCKING SLEEVE	1	HM571
44	SHAFT	1	B470
45	O-RING-012	1	VO-012
46	BAFFLE	1	B461
47	FLOW WASHER K=4 OR 2	1	B410-4
	FLOW WASHER K=4.6 OR 2.3		B410-5
	FLOW WASHER K=6.9		B410-7
	FLOW WASHER K=10 OR 6		B410-10
48	FLAT WASHER 1/4" STAINLESS	1	VW687X281-50
49	1/4-28 X 1/2 BUTTON HEAD SCREW	1	VT25-28BH500
* - SPECIFY THREAD			

10.2 METRO 1

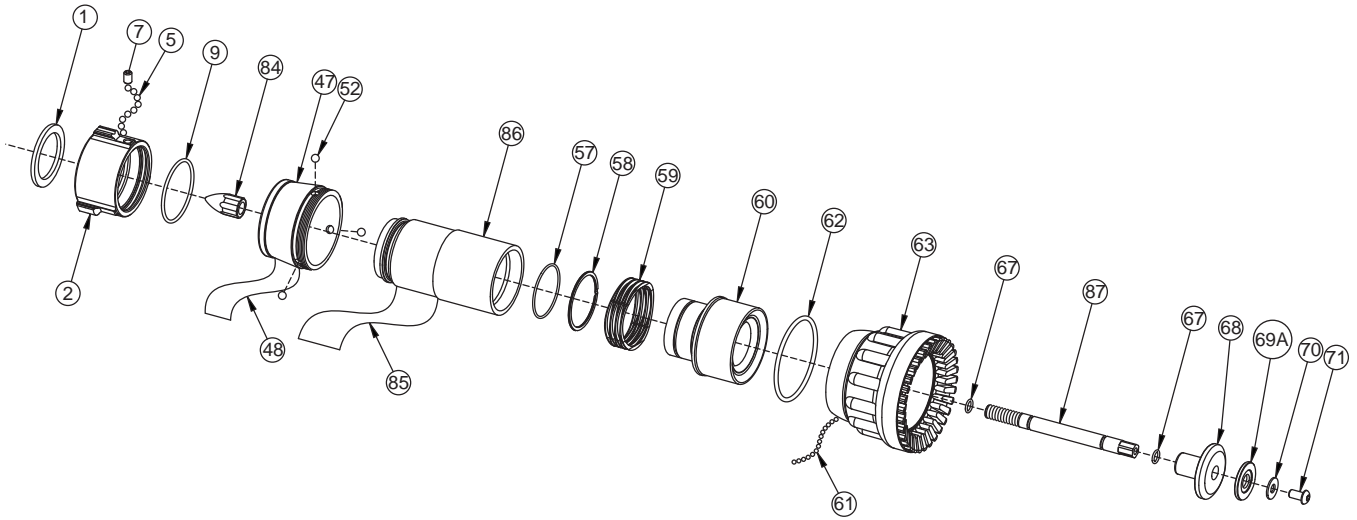

METRO 1 - TIP ONLY

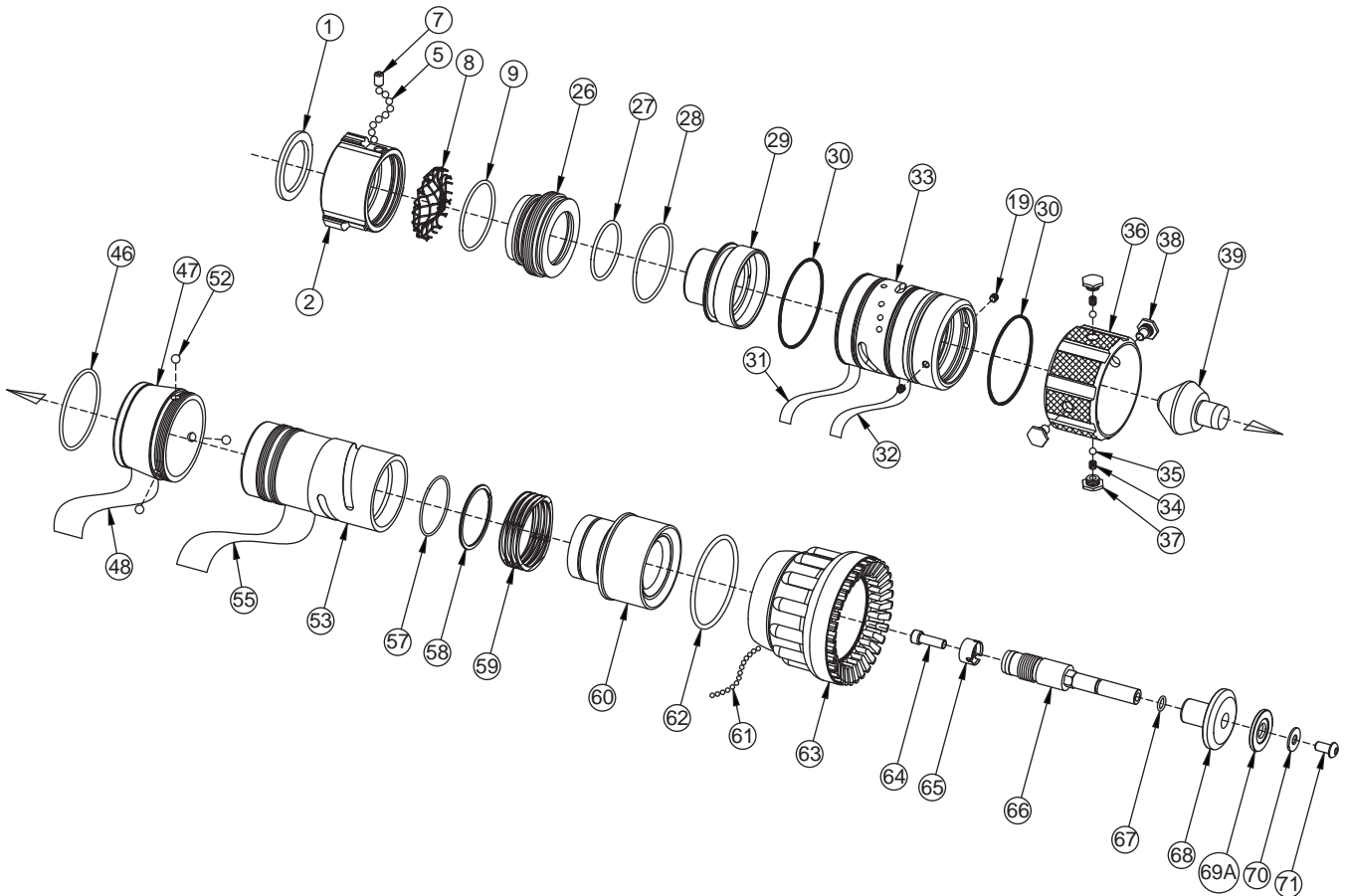

METRO 1 - STO

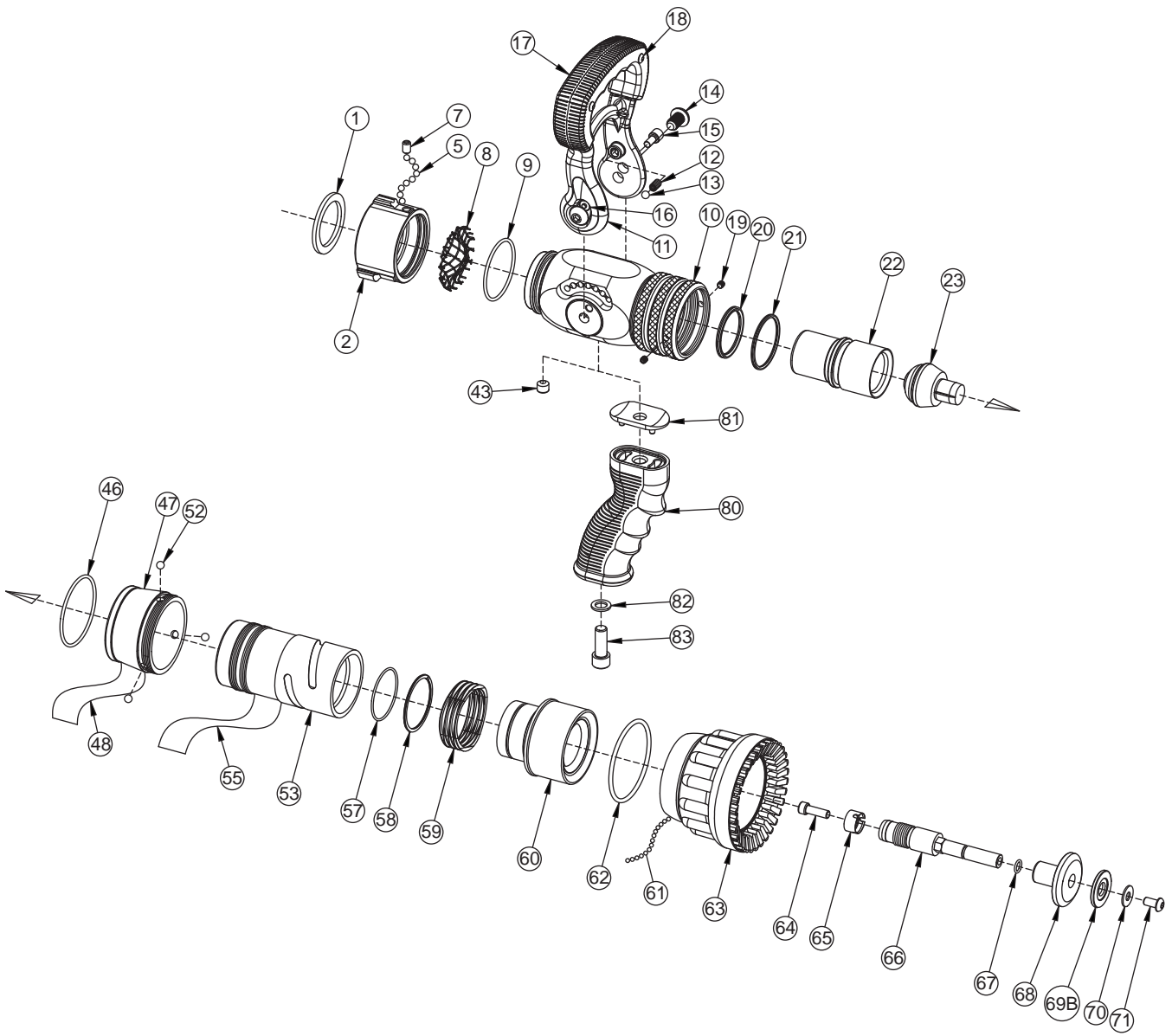

METRO 1 - V AND VPGI

#	DESCRIPTION	QTY	PART #
1	GASKET - 1.5"	1	V3130
2	COUPLING 1.5"NH	1	HM697*
5	3/16" TORLON BALL	33	V2120
7	1/4-28 X 3/16 SOCKET SET SCREW (SWIVEL)	1	VT25-28SS187
	1/4-28 X 3/8 SOCKET SET SCREW (LOCKOUT)		VT25-28SS375
8	1.5" GASKET GRABBER	1	HM730
9	O-RING-134	1	VO-134
10	VALVE BODY	1	HM600
	VALVE DISK	2	HM640
	DRAG NUB	4	HM650
	SMALLEY RING	2	V4270
11	HANDLE	1	HM622
12	DETENT SPRING	2	HM770
13	.243" TORLON BALL	2	VB243TO
14	HANDLE SCREW	2	HM645
15	CAM PIN	1	HM630
16	SAFETY PIN	1	HM635
17	BLACK HANDLE COVER	2	HM625-BLK
18	8-14 X 3/8 PUSHTITE BUTTON HEAD	4	VT08-14PT375
19	10-32 X 3/16 SOCKET SET SCREW	2	VT10Y32SS187
20	QUAD-RING-221	1	VOQ-4221
21	QUAD-RING-130	1	VOQ-4130
22	SLIDER	1	HM660
23	VALVE PLUG	1	HM590
26	STO TAIL PIECE	1	HM662
27	O-RING-129	1	VO-129
28	O-RING-138	1	VO-138
29	STO SLIDER	1	HM661
30	QUAD-RING-037	2	VOQ-4037
31	STO LABEL; VALVE OFF RED	1	HD755
32	STO LABEL; VALVE ON BLUE	1	HD750
33	STO BASE	1	HM655
34	STO DETENT SPRING	2	VM4200
35	3/16" TORLON BALL	2	V2120-TORLON
36	STO SLEEVE	1	HM668
37	DETENT SCREW	2	HD785
38	CAM SCREW	2	HD780
39	S.T.O. VALVE PLUG	1	HM592
43	3/8-16 X 5/16 SOCKET SET SCREW	1	VT37-16SS312
46	O-RING-139	1	VO-139

#	DESCRIPTION	QTY	PART #
46	O-RING-139	1	VO-139
47	SHAPER GUIDE	1	HMD510
48	NAME LABEL: METRO 1 - ORANGE	1	HM745-ORG
52	.243" TORLON BALL	3	VB243TO
53	BARREL	1	HM345
55	BARREL LABEL - ORANGE	1	HM740-ORG
57	O-RING-030	1	VO-030
58	SMALLEY RING	1	VR4230
59	FLUSH WAVE SPRING	1	HM785
60	BARREL CONE	1	HM520
61	1/8" NYLON BALL	64	V2135
62	O-RING-230	1	VO-230
63	SHAPER WITH BUMPER	1	HM500
64	1/4-28 X 3/4 SOCKET HEAD SCREW	1	VT25-28SH750
65	LOCKING SLEEVE	1	HM571
66	SHAFT	1	HM470
67	O-RING-011	2	VO-011
68	BAFFLE	1	HM461
69	FLOW WASHER K=12.5 OR 9.5	1	HM410-14
	FLOW WASHER K=15.0 OR 14.4		HM410-15
	FLOW WASHER K=17.5 OR 17.3		HM410-17
	FLOW WASHER K=26.2 OR 20.2		HM410-21
	FLOW WASHER K=23.1 OR 21.2		HM410-23
70	FLAT WASHER 1/4" STAINLESS	1	VW687E259-50
71	1/4-28 X 1/2 BUTTON HEAD SCREW	1	VT25-28BH500
80	PISTOL GRIP	1	HM692-BLK
81	GRIP SPACER MIDMATIC	1	HM693-HM
82	WASHER	1	VM4901
83	3/8-16 X 1 SOCKET HEAD SCREW	1	VT37-16SH1.0
84	CAP NUT	1	HM320
85	BARREL LABEL - ORANGE	1	HM741-ORG
86	BARREL	1	HM345
87	SHAFT	1	HM370
88	FLOW WASHER K=6.9 OR 6.0	1	HM33006
	FLOW WASHER K=17.7 OR 13.4		HM33013
	FLOW WASHER K=12.5 OR 9.5		HM33014
	FLOW WASHER K=15.0 OR 14.4		HM33015
	FLOW WASHER K=17.5 OR 17.3		HM33017
	FLOW WASHER K=26.2 OR 20.2		HM33021
FLOW WASHER K=23.1 OR 21.2	HM33023		
* - SPECIFY THREAD			

10.3 METRO 2 DRAWING AND PARTS LIST

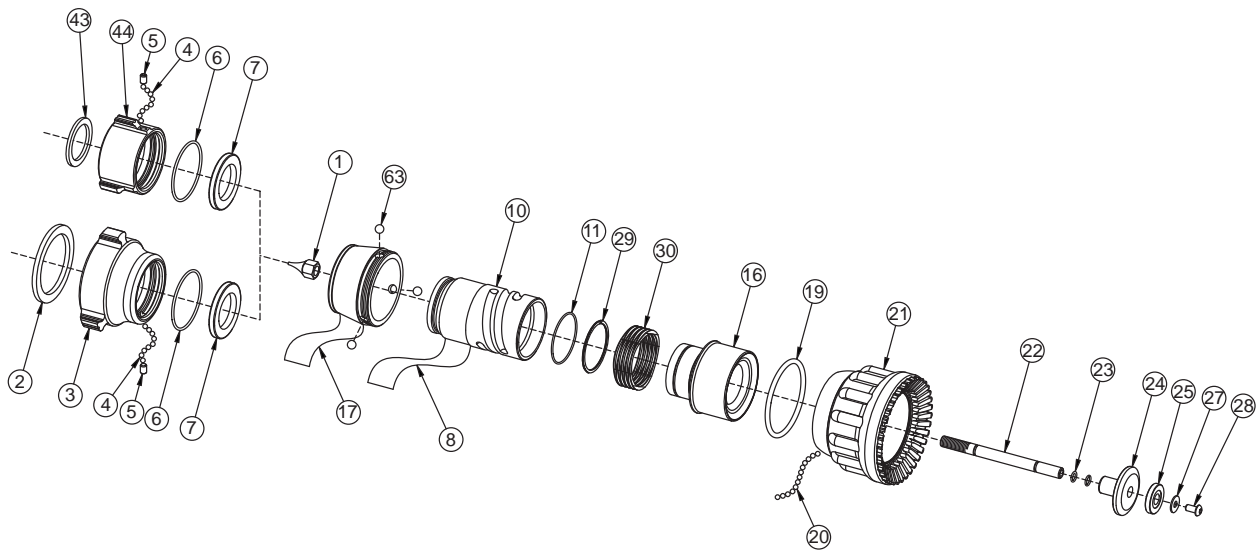

METRO 2 - TIP ONLY

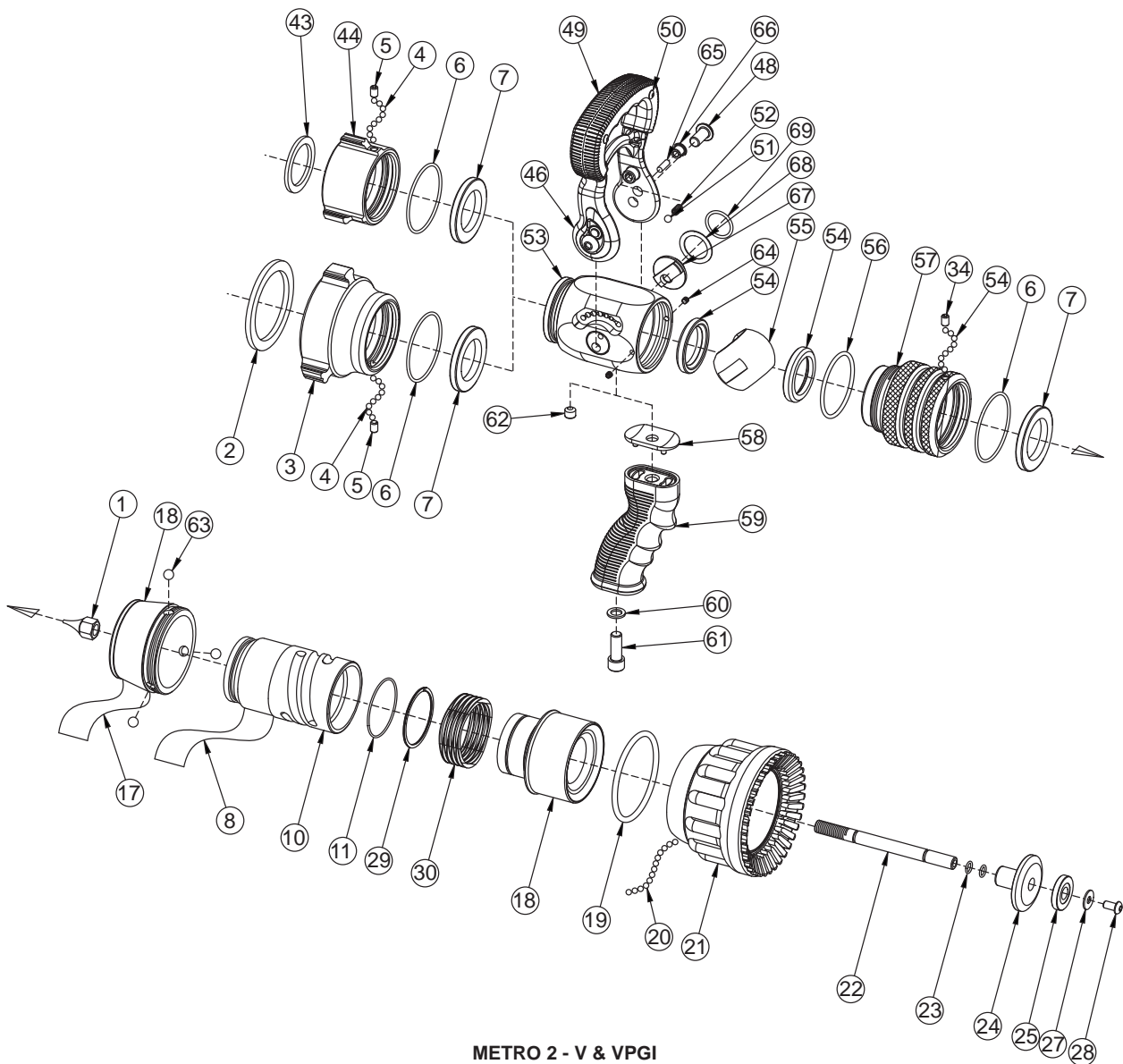

METRO 2 - V & VPGI

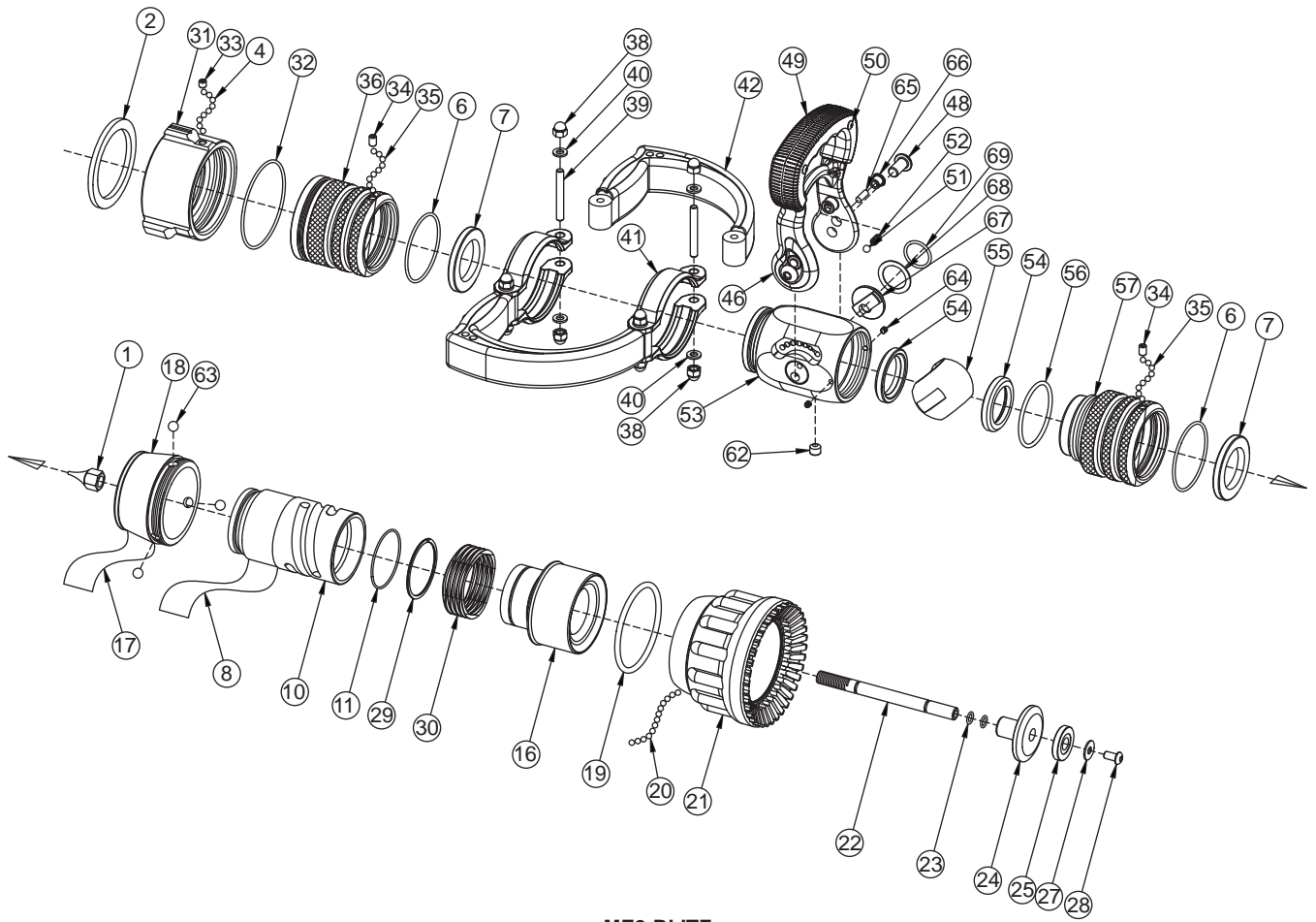

ME2-BLITZ

#	DESCRIPTION	QTY	PART #
1	CAP NUT	1	H420
2	GASKET - 2.5"	1	V3190
3	COUPLING 2.5"NH ROCKERLUG	1	P198N
	COUPLING 2.5"NPSH ROCKERLUG		P198I
4	3/16" SS BALL	48	V2120
5	1/4-28 X 3/16 SOCKET SET SCREW (SWIVEL)	1	VT25-28SS187
	1/4-28 X 3/8 SOCKET SET SCREW (LOCK-OUT)		VT25-28SS375
6	O-RING-141	2	VO-141
7	ANTI GG RING VO	2	P147
8	BARREL LABEL - ORANGE	1	H740-ORG
10	BARREL	1	HX440
11	VO-RING-033	1	VO-033
16	BARREL CONE	1	HX520
17	NAME LABEL - METRO 2 - ORANGE	1	H745-ORG
18	SHAPER GUIDE	1	HXD510
19	O-RING-336	1	VO-336
20	3/16" ACETAL BALL	48	V2115
21	SHAPER WITH BUMPER	1	H500
22	SHAFT	1	HX470
23	VO-RING-011	2	VO-011
24	BAFFLE	1	H461
25	FLOW WASHER K=17.0 OR K=14.4	1	HX410-16
	FLOW WASHER K=23.1 OR K=21.3		HX410-22
	FLOW WASHER K=28.9 OR K=25.0		HX410-26
	FLOW WASHER K=35.4 OR K=32.5		HX410-34
27	FLAT WASHER 1/4" STAINLESS	1	VW687E259-50
28	1/4-28 X 1/2 BUTTON HEAD SCREW	1	VT25-28BH500
29	SMALLEY RING	1	VR4270
30	FLUSH WAVE SPRING	1	HX785
31	COUPLING ROCKERLUG	1	P197*
32	O-RING-151	1	VO-151
33	1/4-28 X 1/4 SOCKET SET SCREW	1	VT25-28SS250
34	1/4-28 X 3/8 SOCKET SET SCREW	1	VT25-28SS375
35	3/16" SS BALL	75	V2120

#	DESCRIPTION	QTY	PART #
36	BLITZ BASE 2.5"	1	H675
38	1/4-20 SS ACORN NUT	8	VT25E20AC
39	1/4-20 X 2 STUD FULL THREAD	4	VT25-20ST2.0
40	WASHER	8	VW500X265-63
41	BLITZ BRACKET	4	H676
42	PLAYPIPE HANDLE	2	P220
43	GASKET - 1.5"	1	V3130
44	COUPLING ROCKERLUG	1	H694*
46	HANDLE	1	HX620
48	3/8-24 X 3/4 BUTTON HEAD SCREW	2	VT37E24BH750
49	BLACK HANDLE COVER	2	HM625-BLK
50	8-14 X 3/8 PUSHTITE BUTTON HEAD	4	VT08-14PT375
51	.243" TORLON BALL	2	VB243TO
52	DETENT SPRING	2	HM770
53	DETENT VALVE BODY	1	P110
	VALVE LABEL - BLUE	1	H750
54	BALL SEAT VALVE	2	P104
55	DELIN VALVE BALL	1	P103
56	O-RING-227	1	VO-227
57	PLAYPIPE ADAPTER	1	HX450
58	GRIP SPACER HANDLINE	1	HM693-H
59	PISTOL GRIP - BLACK	1	HM692-BLK
60	WASHER	1	VM4901
61	3/8-16 X 1 SOCKET HEAD SCREW	1	VT37-16SH1.0
62	3/8-16 X 5/16 SOCKET SET SCREW	1	VT37-16SS312
63	.344" TORLON BALL	3	VB344TO
64	10-32 X 3/16 SOCKET SET SCREW	2	VT10Y32SS187
65	3/16 X 9/16 HDP SPIROL	2	V2005
66	TRUNNION DRIVER	2	HX650
67	TRUNNION - LEFT	1	P120L
	TRUNNION - RIGHT	1	P120R
68	TEFLON TRUNNION SHIM	2	P170
69	O-RING-118	2	VO-118
* - SPECIFY THREAD			

10.4 IMPULSE TRIGGER VALVE

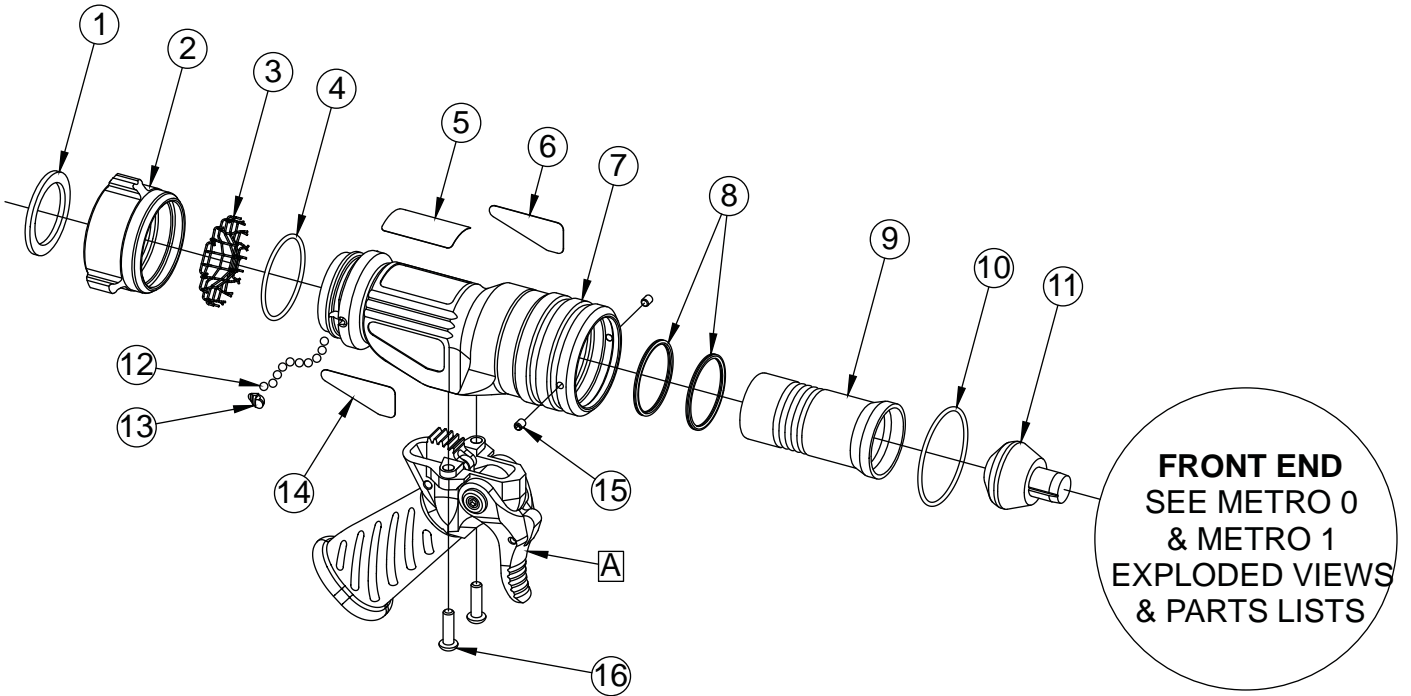

INDEX	DESCRIPTION	QTY	METRO 0		METRO 1	
			ITEM #	ITEM #	ITEM #	ITEM #
1	GASKET 1.0"	1	V3040	N/A		
	GASKET 1.5"		N/A	V3130		
2	COUPLING 1.0"F	1	B680*	N/A		
	COUPLING 1.5"F		N/A	G690*		
	COUPLING 1.5"BSPF STRETCH		N/A	G691B		
3	GASKET GRABBER	1	B730	G606		
4	O-RING-***	1	VO-127	VO-134		
5	LABEL: TOP	1	TN600LT	TN600LT		
6	LABEL: LEFT	1	TN600LL	TN600LL		
7	BODY	1	TN600B	TN600HM		
8	QUAD-RING-***	2	VOQ-4125	VOQ-4130		
9	SLIDER	1	TN660B	TN660HM		
10	O-RING-***	1	VO-030	VO-139		
11	VALVE PLUG	1	TN590B	TN590HM		
12	3/16" SS BALL	*	V2120 (28)	V2120 (34)		
13	PORT PLUG	1	B770	B770		
14	LABEL: RIGHT	1	TN600LT	TN600LT		
15	10-32 X 1/4 SOCKET SET SCREW	2	VT10-32SS250	VT10-32SS250		
16	1/4-20 X 7/8 BUTTON HEAD SCREW	2	VT25-20BH875	VT25-20BH875		
A	TRIGGER GRIP SUBASSEMBLY	1	TN900	TN900		
	HIGH PRESSURE TRIGGER GRIP SUBASSEMBLY		TN900HP	TN900HP		

* - CONSULT FACTORY FOR SPECIAL THREADS

11.0 WARRANTY

Task Force Tips, Inc., 3701 Innovation Way, Valparaiso, Indiana 46383-9327 USA ("TFT") warrants to the original purchaser of its nozzles ("equipment"), and to anyone to whom it is transferred, that the equipment shall be free from defects in material and workmanship during the five (5) year period from the date of purchase.

TFT's obligation under this warranty is specifically limited to replacing or repairing the equipment (or its parts) which are shown by TFT's examination to be in a defective condition attributable to TFT. To qualify for this limited warranty, the claimant must return the equipment to TFT, at 3701 Innovation Way, Valparaiso, Indiana 46383-9327 USA, within a reasonable time after discovery of the defect. TFT will examine the equipment. If TFT determines that there is a defect attributable to it, TFT will correct the problem within a reasonable time. If the equipment is covered by this limited warranty, TFT will assume the expenses of repair.

If any defect attributable to TFT under this limited warranty cannot be reasonably cured by repair or replacement, TFT may elect to refund the purchase price of the equipment, less reasonable depreciation, in complete discharge of its obligations under this limited warranty. If TFT makes this election, claimant shall return the equipment to TFT free and clear of any liens and encumbrances.

This is a limited warranty. The original purchaser of the equipment, any person to whom it is transferred, and any person who is an intended or unintended beneficiary of the equipment, shall not be entitled to recover from TFT any consequential or incidental damages for injury to person and/or property resulting from any defective equipment manufactured or assembled by TFT. It is agreed and understood that the price stated for the equipment is in part consideration for limiting TFT's liability. Some states do not allow the exclusion or limitation of incidental or consequential damages, so the above may not apply to you.

TFT shall have no obligation under this limited warranty if the equipment is, or has been, misused or neglected (including failure to provide reasonable maintenance) or if there have been accidents to the equipment or if it has been repaired or altered by someone else.

THIS IS A LIMITED EXPRESS WARRANTY ONLY. TFT EXPRESSLY DISCLAIMS WITH RESPECT TO THE EQUIPMENT ALL IMPLIED WARRANTIES OF MERCHANTABILITY AND ALL IMPLIED WARRANTIES OF FITNESS FOR A PARTICULAR PURPOSE. THERE IS NO WARRANTY OF ANY NATURE MADE BY TFT BEYOND THAT STATED IN THIS DOCUMENT.

This limited warranty gives you specific legal rights, and you may also have other rights which vary from state to state.

12.0 MAINTENANCE

TFT nozzles are designed and manufactured to be damage resistant and require minimal maintenance. However, as the primary firefighting tool upon which your life depends, it should be treated accordingly. Do not drop or throw equipment.

12.1 FIELD LUBRICATION

All Task Force Tip nozzles are factory lubricated with high quality silicone grease. This lubricant has excellent washout resistance and long term performance. If your department has unusually hard or sandy water, the moving parts may be affected. Foam agents and water additives contain soaps and chemicals that may break down the factory lubrication.

The moving parts of the nozzle should be checked on a regular basis for smooth and free operation, and signs of damage. IF THE NOZZLE IS OPERATING CORRECTLY, THEN NO ADDITIONAL LUBRICATION IS NEEDED. Any nozzle that is not operating correctly should be immediately removed from service.

The field use of Break Free CLP (spray or liquid) lubricant will help to restore the smooth and free operation of the nozzle. However, these lubricants do not have the washout resistance and long-term performance of the silicone grease. Therefore, re-application of Break Free CLP will be needed on a regular basis. CAUTION: Aerosol lubricants contain solvents that can swell O-Rings if applied in excess. The swelling can inhibit smooth operation of the moving parts. When used in moderation, as directed, the solvents quickly evaporate without adversely swelling the O-Rings.

The nozzle can be returned to the factory for a complete checkup and re-lubrication with silicone grease

PART ONE — COUPLING DOWN

Position the nozzle at a 45-degree angle with the COUPLING end down. CLOSE the valve handle and set the pattern to STRAIGHT STREAM. Then spray a short burst into these areas:

#1 FRONT PATTERN CONTROL SEAL

Spray in between the pattern control and the barrel.

#2 PRESSURE CONTROL UNIT

Place check sticks behind baffle while shaper is in flush. Cycle baffle in and out using check sticks several times to work lubrication into o-rings.

#3 FRONT SLIDER SEAL

- Rotate shaper into FLUSH position.
- Spray down the front end of the nozzle to dribble lubricant into the clearances between the shaper and the valve body.

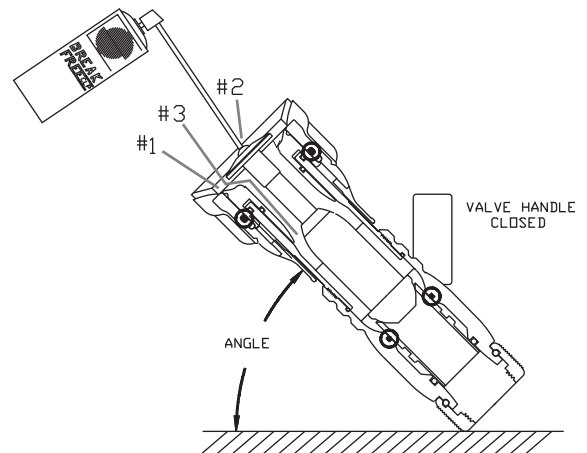

While holding nozzle at the angle, wait 30 seconds for the lubricant to penetrate into the clearances. Cycle the valve handle and rotate the shaper from straight stream to full flush several times, and then proceed to the next section.

PART TWO — COUPLING UP

Position the nozzle at a 45-degree angle with the BUMPER end down. OPEN the valve handle and set the pattern to FLUSH. Spray a short burst in these areas:

#4 REAR SHAPER SEAL

Spray down the clearance between the label and the shaper guide.

#5 REAR SLIDER SEAL

Spray into the clearance between the slider and the valve body.

#6 FLUSH MECHANISM SEAL

- With the handle on the top, spray down into the nozzle. The aerosol extension tip will help direct the spray into clearances leading to the O-Ring.
- Rotate nozzle so the valve is on the bottom and spray another short burst.

#7 DETENTS IN THE HANDLE

Spray a small amount on the detent followers located in the handle.

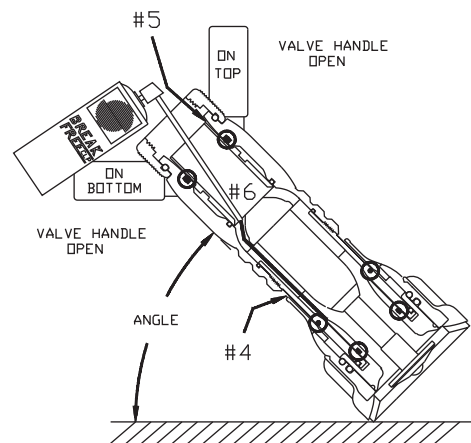

While holding nozzle at the angle, wait 30 seconds, then cycle the valve handle several times. Rotate the pattern control from straight stream to full flush several times. The pattern control should move freely and easily. The barrel cone should move forward to within 1/16" of the baffle before the shaper reaches straight stream position. Wipe off excess lubricant.

IF THIS PROCEDURE DOES NOT RESTORE SMOOTH AND FREE OPERATION OF ALL THE MOVING PARTS, THEN FACTORY SERVICE IS NEEDED. • 24-HOUR HOT LINE — 800-348-2686 • www.tft.com

12.2 IMPULSE TRIGGER VALVE LUBRICATION

- 1) Insert tube from BreakFree into drain hole in pistol grip.
- 2) With nozzle upside down spray a 2 second burst into the pistol grip. Holding a rag around the tube here can help keep excess BreakFree from the outside of the nozzle.
- 3) Keep nozzle upside down for at least 10 seconds to allow the BreakFree to flow into the valve area.
- 4) Check for smooth and free operation of the trigger. Repeat a second time if needed.

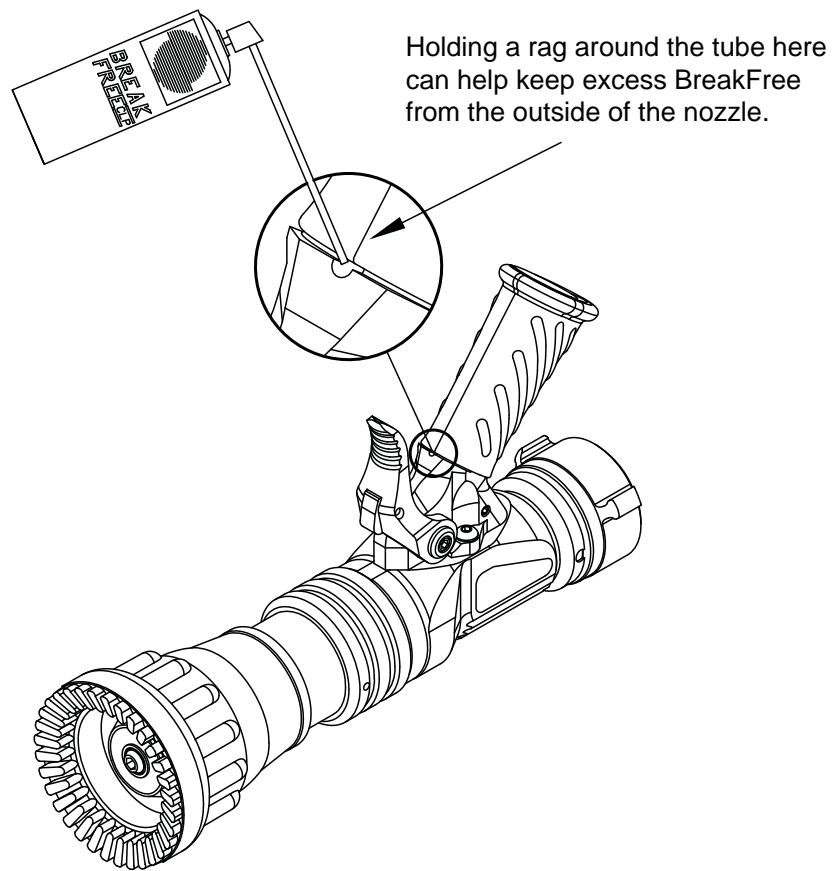

**If this procedure does not restore trigger operation then factory service is needed.
24 hour Technical Service and Support - 800-348-2686 - www.tft.com**

12.3 SERVICE TESTING

In accordance with NFPA 1962 (2013), nozzles must be tested a minimum of annually. Nozzles failing any part of this test must be removed from service, repaired and retested upon completion of the repair.

12.3.1 HYDROSTATIC TESTING

Each nozzle with a shut off mechanism shall be tested in the following manner.

- 1. The nozzle shall be placed in a device capable of holding it and the shut off shall be closed.*
- 2. A device capable of exerting a hydrostatic pressure of 300 psi (2070 kPa) or 1.5 times the maximum operating pressure, whichever is higher, shall be attached to the nozzle.*
- 3. All air shall be bled from the system.*
- 4. The gage pressure shall be increased by 50 psi (3.5 bar or 345 kPa) increments, held for 30 seconds at each pressure up to the maximum pressure for which the nozzle is being tested, and then held for one minute without leakage.*
- 5. There shall be no sign of leakage through the valve or shut off.*

12.3.2 FLOW TESTING

Flow testing must be conducted in the following manner.

- 1. The nozzle shall be mounted so that the flow rate and pressure through the nozzle and the pressure at the inlet can be accurately measured.*
- 2. With the shut off fully open, the inlet pressure shall be adjusted to the rated pressure ± 2 percent.*
- 3. The valve or shut off and pattern controls shall be operated through their full range of motion at 100 psi (6.9 bar or 690 kPa) with no signs of leaking, binding or other problems.*
- 4. Evaluate the flow of nozzles as defined by NFPA 1964 in the following manner:*
 - Automatic (Constant Pressure) Spray Nozzles*
 - 1. The flow rate shall slowly be increased to the maximum rated flow, and the minimum and maximum pressures through the flow range recorded.*
 - 2. Nozzles shall maintain their rated pressure ± 15 psi (± 1 bar or ± 100 kPa) throughout the rated flow range.*

12.3.3 RECORDS

A record of testing and repairs must be maintained from the time the nozzle is purchased until it is discarded. Each TFT nozzle is engraved with a unique serial number which, if so desired, can be used to identify nozzle for documentation purposes.

The following information, if applicable, must be included on the test record for each nozzle:

- 1. Assigned identification number*
- 2. Manufacturer*
- 3. Product or model designation*
- 4. Vendor*
- 5. Warranty*
- 6. Hose connection size*
- 7. Maximum operating pressure*
- 8. Flow rate or range*
- 9. Date received and date put in service*
- 10. Date of each service test and service test results*
- 11. Damage and repairs, including who made the repairs and the cost of repair parts*
- 12. Reason removed from service*

NFPA 1962: Standard for the care, use, inspection, service testing, and replacement of fire hose, couplings, nozzles and fire hose appliances. (2013 ed., Section 5.5.4). Quincy, MA: National Fire Protection Agency.

12.4 REPAIR

Factory service is available with repair time seldom exceeding one day in our facility. Factory-serviced nozzles are repaired by experienced technicians, wet tested to original specifications, and promptly returned. Repair charges for non-warranty items are minimal. Any returns should include a note as to the nature of the problem and whom to reach in case of questions.

Repair parts and service procedures are available for those wishing to perform their own repairs. Task Force Tips assumes no liability for damage to equipment or injury to personnel that is a result of user service. Contact the factory or visit the web site at www.tft.com for parts lists, exploded views, test procedures and troubleshooting guides.

Performance tests shall be conducted on the nozzle after a repair, or anytime a problem is reported to verify operation in accordance with TFT test procedures. Consult factory for the procedure that corresponds to the model and serial number of the nozzle. Any equipment which fails the related test criteria should be removed from service immediately. Troubleshooting guides are available with each test procedure or equipment can be returned to the factory for service and testing.

CAUTION

Any alterations to the nozzle and its markings could diminish safety and constitutes a misuse of this product.

13.0 OPERATION AND INSPECTION CHECKLIST

BEFORE EACH USE the nozzle must be inspected to this checklist:

- 1) There is no obvious damage such as missing, broken or loose parts, corrosion, damaged labels etc.
- 2) Debris screen is free of debris
- 3) Coupling is tight and leak free
- 4) Valve operates freely through full range and regulates flow
- 5) "OFF" position does fully shut off and flow is stopped
- 6) Nozzle flow is adequate as indicated by pump pressure and nozzle reaction
- 7) Shaper turns freely and adjusts pattern through full range
- 8) Shaper turns into full flush and out of flush with normal flow and pressure restored

BEFORE BEING PLACED BACK IN SERVICE, nozzles must be inspected to this checklist;

- 1) All controls and adjustments are operational
- 2) Shut off valve (if so equipped) closes off the flow completely
- 3) There are no broken or missing parts
- 4) There is no damage to the nozzle
- 5) The thread gasket is in good condition
- 6) The waterway is clear of obstructions
- 7) Nozzle is clean and markings are legible
- 8) Coupling is retightened properly
- 9) Shaper is set to desired pattern
- 10) Shutoff handle is stored in the OFF position

NFPA 1962: Standard for the care, use, inspection, service testing, and replacement of fire hose, couplings, nozzles and fire hose appliances. (2013 ed., Section 5.2.2). Quincy, MA: National Fire Protection Agency.

WARNING

Any nozzle failing any part of the checklist is unsafe for use and must have the problem corrected before use or being placed back into service. Operating a nozzle that has failed the checklist is a misuse of this equipment.