



MANUAL: Deluge Nozzles With Fixed & Selectable Flow

INDUSTRIAL & MASTERSTREAM 1000 INSTRUCTIONS FOR SAFE OPERATION AND MAINTENANCE

⚠WARNING

Read instruction manual before use. Operation of this device without understanding the manual and receiving proper training is a misuse of this equipment. A person who has not read and understood all operating and safety instructions is not qualified to operate the Industrial and Masterstream nozzle.

This instruction manual is intended to familiarize firefighters and maintenance personnel with the operation, servicing and safety procedures associated with the Industrial and Masterstream firefighting nozzles.

This manual should be kept available to all operating and maintenance personnel.

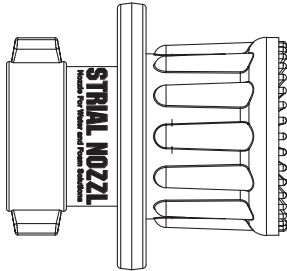

INDUSTRIAL

350, 500 or 750 GPM @ 100 PSI

1300, 2000, or 3000 LPM @ 7 BAR (700 KPA)

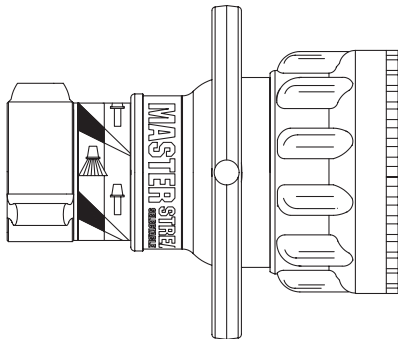

MASTERSTREAM 1000 SELECTABLE

250, 350, 500, 750, 1000 GPM @ 100 PSI

500, 1000, 1500, 2000, 2500 LPM @ 7 BAR (700 KPA)

1000, 1500, 2000, 2500, 3000, 4000 LPM @ 7 BAR (700 KPA)

1200, 1800, 2400, 3000, 3600, 4800 LPM @ 10 BAR (1000 KPA)

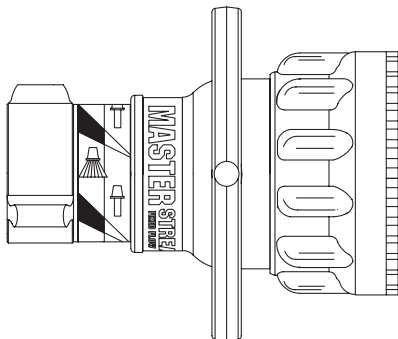

MASTERSTREAM 1000 FIXED

1000 GPM MAX @ 100 PSI

4000 LPM MAX @ 7 BAR (700 KPA)

TASK FORCE TIPS, Inc.
Made in USA • www.tft.com



2800 E Evans Ave • Valparaiso, IN 46383-6940 USA
800-348-2686 • 219-462-6161 • Fax 219-464-7155

TABLE OF CONTENTS

<p>1.0 MEANING OF SAFETY SIGNAL WORDS</p> <p>2.0 GENERAL INFORMATION</p> <p>2.1 USE WITH SALT WATER</p> <p>2.2 VARIOUS MODELS AND TERMS</p> <p>2.3 PATTERN CONTROL</p> <p>2.4 USE WITH FOAM</p> <p style="padding-left: 20px;">2.4.1 FOAMJET LX WITH MASTERSTREAM NOZZLE</p> <p>3.0 FLOW CHARACTERISTICS OF INDUSTRIAL NOZZLE</p>	<p>3.1 FLOW CHARACTERISTICS OF MASTERSTREAM SELECTABLE NOZZLE</p> <p>3.2 FLOW CHARACTERISTICS OF MASTERSTREAM FIXED NOZZLE</p> <p>3.3 DETERMINING FLOW WITH PRE-PIPED MONITORS</p> <p>3.4 STREAM TRAJECTORY DATA</p> <p>4.0 FLUSHING DEBRIS</p> <p>5.0 MAINTENANCE</p> <p>6.0 WARRANTY</p>
---	---

1.0 MEANING OF SAFETY SIGNAL WORDS

A safety related message is identified by a safety alert symbol and a signal word to indicate the level of risk involved with a particular hazard. Per ANSI standard Z535.4-1998 the definitions of the three signal words are as follows:

	DANGER indicates an imminently hazardous situation which, if not avoided, will result in death or serious injury.
	WARNING indicates a potentially hazardous situation which, if not avoided, could result in death or serious injury.
	CAUTION indicates a potentially hazardous situation which, if not avoided, may result in minor or moderate injury.

2.0 GENERAL INFORMATION

The Task Force Tips Industrial and Masterstream nozzles are deluge nozzles with clean far reaching straight stream. They are adjustable from straight stream to a dense fog pattern. Their rugged construction is compatible with the use of fresh water as well as fire fighting foam solutions. A summary of each nozzle's characteristics is shown in the tables below.

	WARNING This equipment is intended for use by trained personnel for firefighting. Their use for other purposes may involve hazards not addressed by this manual. Seek appropriate guidance and training to reduce risk of injury.
---	--

FIXED FLOW NOZZLES

SERIES	FLOW (GPM)	PRESSURE (PSI)	FLOW (LPM)	PRESSURE (BAR, KPA/100)
INDUSTRIAL	350, 500, 750	100	1300, 2000, 3000	7
MASTERSTREAM 1000	CUSTOMER SPECIFIED: 1000 GPM MAX	CUSTOMER SPECIFIED: 150 PSI MAX	CUSTOMER SPECIFIED: 4000 LPM MAX	CUSTOMER SPECIFIED: 10 BAR MAX

MASTERSTREAM SELECTABLE FLOW NOZZLES

FLOW (GPM)	PRESSURE (PSI)	FLOW (LPM)	PRESSURE (BAR, KPA/100)
250, 350, 500, 750, 1000	100	1000, 1500, 2000, 3000, 4000	7
		1200, 1800, 2400, 3600, 4800	10

NOTES ON TABLES:

- 2 ½ inch NH female threads are standard. Other threads and coupling sizes can be specified at time of order.
- Industrial series nozzle is available in UNS C83600 brass or hardcoat anodized ANSI 356 aluminum.
- Masterstream series nozzle is constructed of hardcoat anodized 6061-T6 aluminum.
- Masterstream series nozzle is also available in automatic pressure control models. See catalog for details.



Nozzle must be properly connected. Mismatched or damaged threads may cause nozzle to leak or uncouple under pressure and could cause injury.



Do not couple aluminum to brass. Dissimilar metals coupled together can cause galvanic corrosion that can result in inability to unscrew threads or complete loss of thread engagement.



Injury can occur from an inadequately supported nozzle. The mounting must be capable of supporting the nozzle reaction force which can be in excess of 550 LBS (1000 GPM at 100 PSI).



Some volatile liquids can be ignited by static discharge. Static build-up can occur from:

- Electrochemical separation of charge as water drains through low conductivity, refined products.
- Applying foam over a low conductivity liquid of sufficient depth to retain the charge created as the foam blanket drains.
- Streaming currents as water or foam is introduced into the storage tank.¹



Water is a conductor of electricity. Application of water solutions on high voltage equipment can cause injury or death by electrocution. The amount of current that may be carried back to the nozzle will depend on the following factors:

- Voltage of the line or equipment
- Distance from the nozzle to the line or equipment
- Size of the stream
- Whether the stream is solid or broken
- Purity of the water²

¹ Electrostatic Hazards of Foam Blanketing Operations by Peter Howels. Industrial Fire Safety July/August 1993
² The Fire Fighter and Electrical Equipment, The University of Michigan Extension Service, Fourth Printing 1983. Page 47.

2.1 USE WITH SALT WATER

Use with salt water is permissible provided nozzle is thoroughly cleaned with fresh water after each use. The service life of the nozzle may be shortened due to the effects of corrosion and is not covered under warranty.

2.2 VARIOUS MODELS AND TERMS

See figures 1A, 1B and 1C for views of the Industrial and Masterstream nozzles. The Masterstream Series Nozzle is available without halo ring. See catalog for model numbers and details.

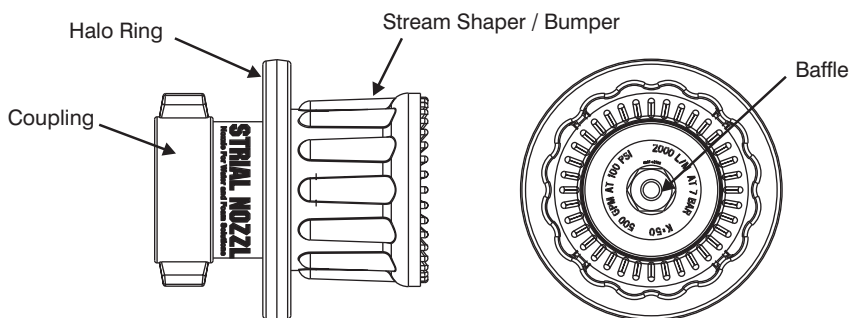

FIG 1A - Industrial Nozzle

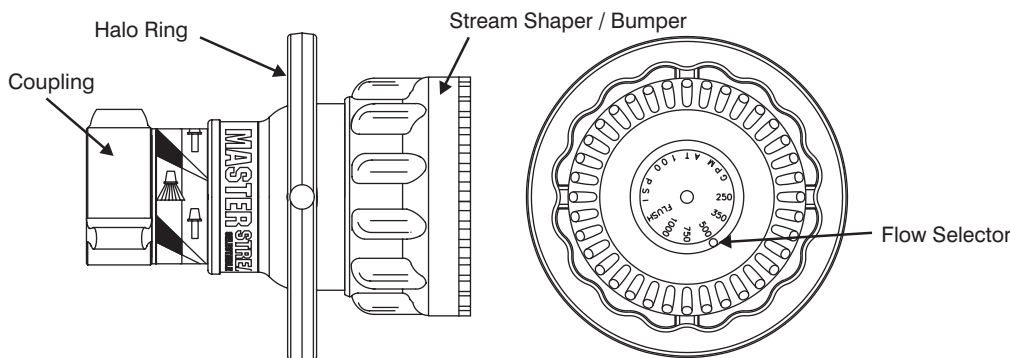

FIG 1B - Masterstream 1000 Selectable Gallonage Nozzle

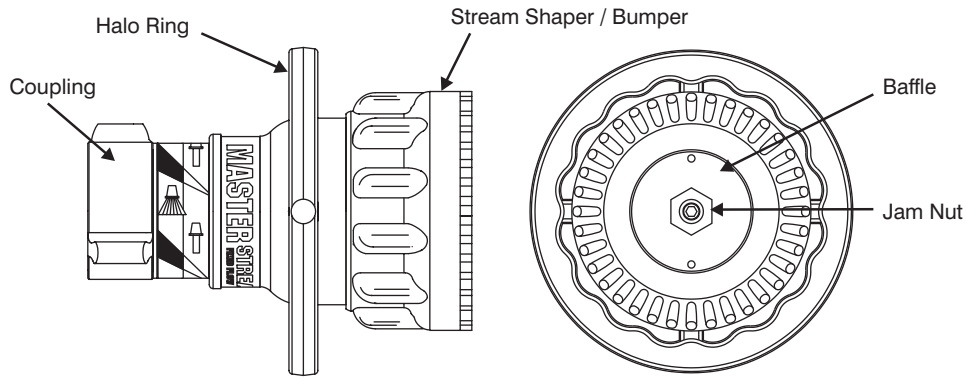

FIG 1C - Masterstream 1000 Fixed Gallonage Nozzle

2.3 PATTERN CONTROL

TFT's Industrial and Masterstream nozzles have full pattern control from straight stream to wide fog. Turning the stream shaper clockwise (as seen from the operating position behind the nozzle) moves the shaper to the straight stream position. Turning the stream shaper counterclockwise will result in an increasingly wider pattern.

Since the stream trim point varies with flow, the stream trim point should be "trimmed" after changing the flow to obtain the straightest and farthest reaching stream. To properly trim a stream, first open the pattern to narrow fog. Then close the stream to parallel to give maximum reach. Note: Turning the shaper further forward will cause stream crossover and reduce the effective reach of the nozzle.

Note: Models are also available with linear (push/pull), remote electric or hydraulic actuation of the stream shaper.

2.4 USE WITH FOAM

The Industrial and Masterstream nozzles may be used with foam solutions. Refer to fire service training for the proper use of foam.



For Class B fires, lack of foam or interruption in the foam stream can cause a break in the foam blanket and greatly increase the risk of injury or death. Assure that:

- Application rate is sufficient (see NFPA 11 or foam manufacturer's recommendations).
- Enough concentrate is on hand to complete task (see NFPA for minimum duration time requirements).
- Foam logistics have been carefully planned. Allow for such things as:
 - Storage of foam in a location not exposed to the hazard it protects.
 - Personnel, equipment and technique to deliver foam at a rapid enough rate.
 - Removal of empty foam containers.
 - Keeping clear path to deliver foam as hoses, other equipment and vehicles are deployed.



Improper use of foam can result in injury or damage to the environment. Follow foam manufacturer's instructions and fire service training to avoid:

- Using wrong type of foam on a fire, i.e. Class A foam on a Class B fire.
- Plunging foam into pools of burning liquid fuels.
- Causing environmental damage.
- Directing stream at personnel.



There is a wide variety of foam concentrates. Each user is responsible for verifying that any foam concentrate chosen to be used with this unit has been tested to assure that the foam obtained is suitable for the purpose intended.

2.4.1 FOAMJET LX WITH MASTERSTREAM NOZZLE

To increase the expansion ratio Task Force Tips "Foamjet LX" (model FJ-LX-M) may be used with the Masterstream nozzle. This low expansion foam tube attaches and detaches quickly from the nozzle. Note: As expansion ratio is increased, the reach of the stream will be decreased due to the greater amount of bubbles in the stream and their inability to penetrate the air. Generally, the reach with foam is approximately 10% less than with water only. Actual results will vary based on brand of foam, hardness of water, temperature, etc.

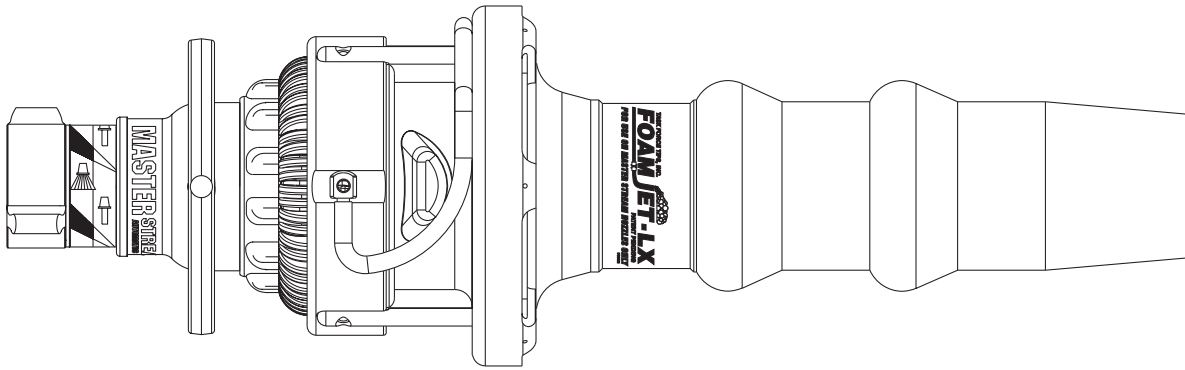

FIG 2 - FJ-LX-M Shown on Masterstream Nozzle

3.0 FLOW CHARACTERISTICS OF INDUSTRIAL NOZZLE

The Industrial Nozzle is manufactured to a predetermined fixed orifice. The orifice size is not adjustable and is specified at time of order. 350, 500 and 750 GPM flow rates at 100 PSI are available. The flow rate is marked on the nozzle's baffle. Figure 3 gives relationship of flow and pressure for various orifice sizes.

3.1 FLOW CHARACTERISTICS OF MASTERSTREAM 1000 SELECTABLE NOZZLE

The Masterstream 1000 Selectable Nozzle allows the user to select one of several orifice sizes by turning a knob at the front of the nozzle. An indicator on the knob shows which flow has been selected. Figure 3 gives relationship of flow and pressure for various orifice sizes.

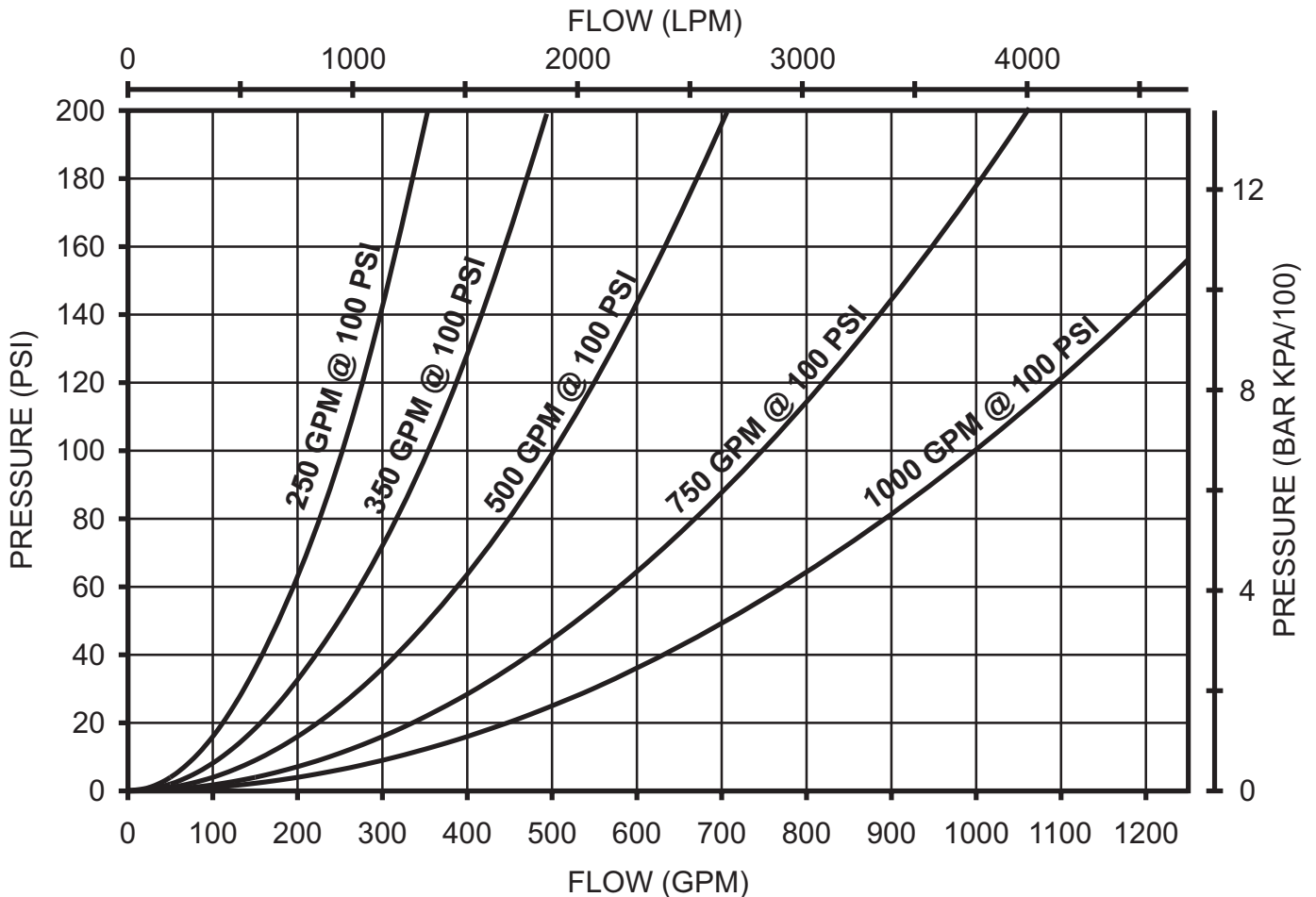

FIG 3 - Nozzle Flow Characteristics

3.2 FLOW CHARACTERISTICS OF MASTERSTREAM 1000 FIXED NOZZLE

The Masterstream 1000 Fixed Flow Nozzle is set to the desired flow by adjusting the baffle and locking it in place with a jam nut. The nozzle is adjusted and flow tested at the factory at time of order. If the baffle is moved (for example to flush the nozzle), then the baffle must be readjusted to obtain the desired flow. Refer to figure 3.0 for baffle position to achieve a certain flow and pressure. Figure 4 gives relationship of flow and pressure for various orifice sizes.

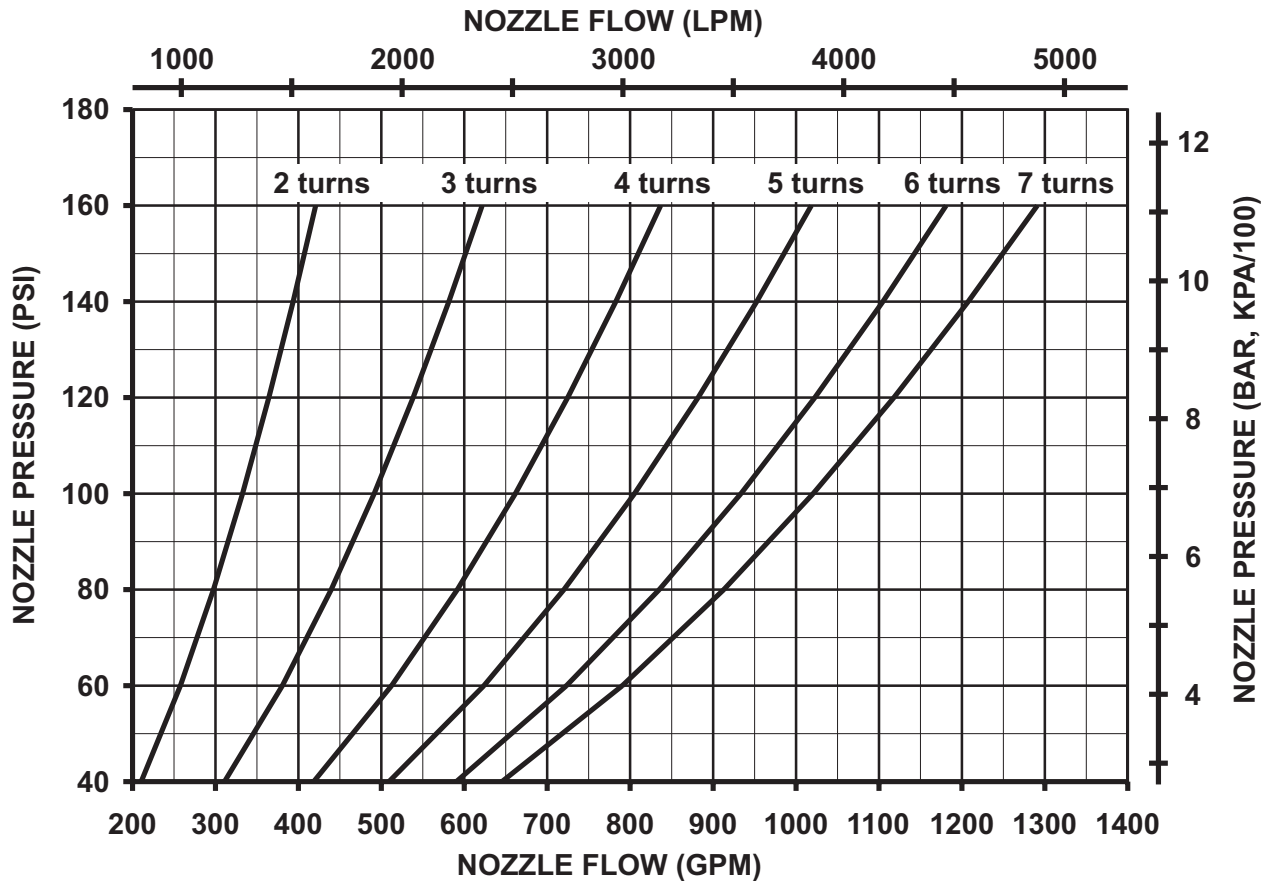

FIG 4 - Nozzle flow vs. baffle turns from closed position for Masterstream Fixed Nozzle



WARNING An inadequate supply of nozzle pressure and/or flow will cause an ineffective stream and can result in injury, death or loss of property.

3.3 DETERMINING FLOW WITH PRE-PIPED MONITORS

The simplest procedure to determine flow is with a flow meter. If a flow meter is unavailable then the flow may be estimated using pressure loss data between the nozzle and an in-line pressure gauge at the pump or considerably upstream from the nozzle. Data is taken with a smooth bore nozzle and handheld pitot gauge. Note: equations assume no substantial change in elevation between in-line pressure gauge and nozzle.

Step1: Determine flow of smooth bore nozzle.

Flow water with a smooth bore nozzle and record the nozzle's size, pitot pressure and in-line pressure gauge reading. The smooth bore nozzle's flow is calculated from the Freeman formula:

$$Q_{\text{nozzle}} = F \times D^2 \sqrt{P_{\text{pitot}}}$$

- Where:
- F = 29.71 for English units (GPM, INCHES, PSI)
 - F = .667 for metric units (LPM, MM, BAR) Note: 1 BAR=100 KPA
 - Q_{nozzle} is smooth bore nozzle flow in GPM (or LPM)
 - D is nozzle exit diameter in INCHES (or MM)
 - P_{pitot} is pitot pressure in PSI (or BAR)

Step 2: Find piping pressure loss constant.

Using the results from step 1 use the following equation to calculate the pressure loss constant between the in-line pressure gauge and the nozzle.

$$C_{\text{piping}} = \frac{Q^2_{\text{smooth}}}{P_{\text{in-line}} - P_{\text{pitot}}}$$

Where: C_{piping} is pressure loss constant in GPM²/PSI (or LPM²/BAR)
 $P_{\text{in-line}}$ is in-line pressure gauge reading in PSI (or BAR)

Step 3: Calculate nozzle constant.

Where: C_{nozzle} is the nozzle's constant in GPM²/PSI (or LPM²/BAR)
 Q_{nominal} is the nozzle's nominal flow in GPM (or LPM)
 P_{nominal} is the nozzle's nominal pressure in PSI (or BAR)

$$C_{\text{nozzle}} = \frac{Q^2_{\text{nominal}}}{P_{\text{nominal}}}$$

Step 4: Calculate flow.

Using the pressure loss constant from step 2, the nozzle constant from step 3, and the in-line pressure gauge reading, the flow with a fixed orifice nozzle can be calculated with the following equation.

$$Q = \sqrt{\frac{C_{\text{piping}} \times C_{\text{nozzle}} \times P_{\text{in-line}}}{(C_{\text{piping}} + C_{\text{nozzle}})}}$$

Where: Q is fixed orifice nozzle's flow in GPM (or LPM)

Mount a graph or table of the results adjacent to the in-line pressure gauge. Deliver any desired flow by adjustment of pump pressure.

3.4 STREAM TRAJECTORY DATA

Figure 5 gives the stream trajectory for the Industrial and Masterstream nozzles at various pressures. The graphs represent orifice sizes of 250, 350, 500, 750 and 1000 GPM at 100 PSI. For other orifice sizes and pressures the graphs may be interpolated.

Notes on trajectory graphs:

- Graphs show approximate effective stream trajectory at 30 degrees elevation in no wind conditions. Distance to last water drops approximately 10% farther.
- Trajectories shown are for water. The addition of foam is expected to decrease the reach by approximately 10%.
- Tail or head winds of 20 MPH (30 KPH) may increase or decrease the range approximately 30%.

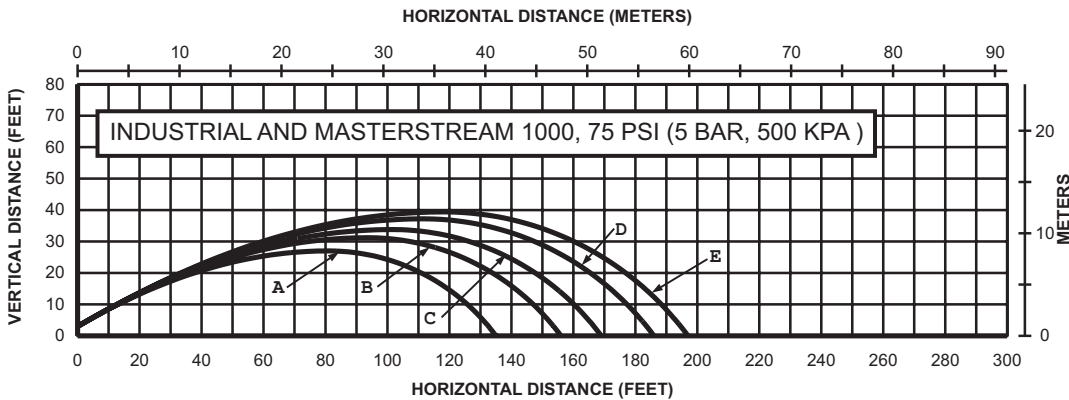

CURVE	GPM FLOW	LBS REACTION
A	200	100
B	300	140
C	430	200
D	650	300
E	870	400

CURVE	LPM FLOW	KGf REACTION
A	830	45
B	1100	60
C	1600	90
D	2500	140
E	3300	180

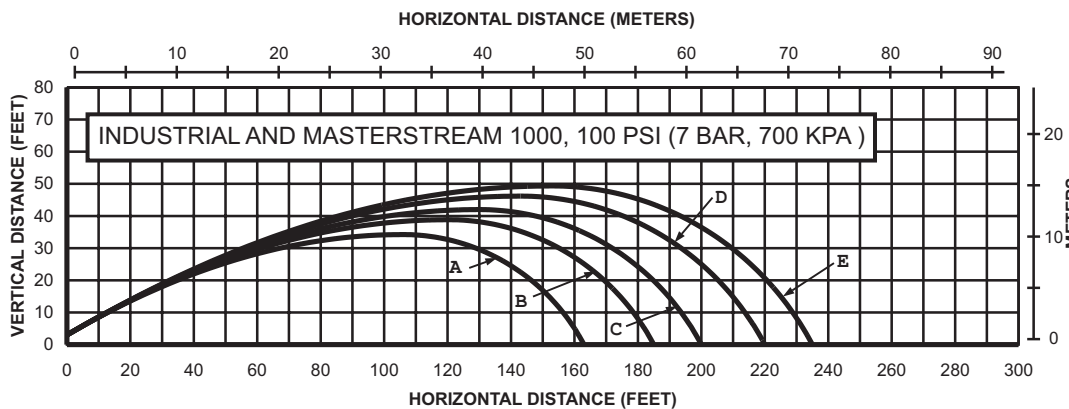

CURVE	GPM FLOW	LBS REACTION
A	250	130
B	350	190
C	500	270
D	750	400
E	1000	530

CURVE	LPM FLOW	KGf REACTION
A	950	60
B	1300	80
C	1900	120
D	2800	180
E	3800	240

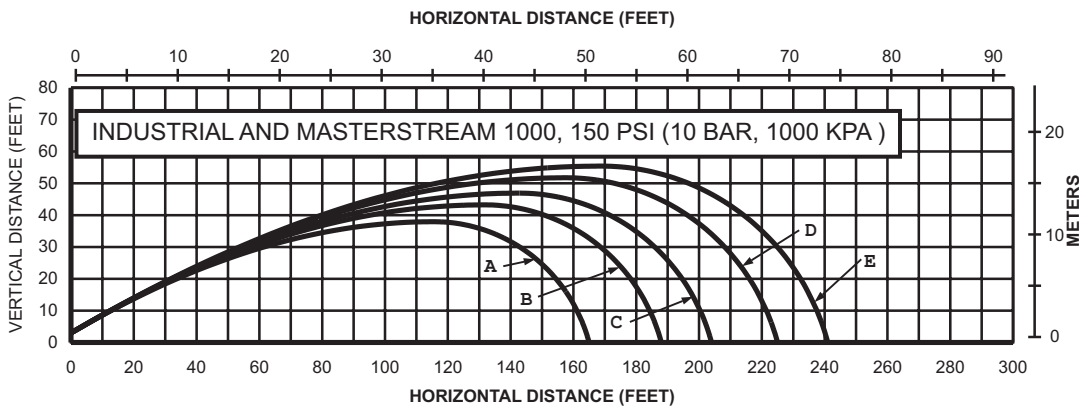

CURVE	GPM FLOW	LBS REACTION
A	310	200
B	430	280
C	610	400
D	920	600
E	1200	780

CURVE	LPM FLOW	KGf REACTION
A	1200	90
B	1600	120
C	2300	180
D	3500	270
E	4500	350

FIG 5 - Industrial and Masterstream Nozzle Stream Trajectory

4.0 FLUSHING DEBRIS

Debris in the water may get caught inside the nozzle. This trapped material will cause poor stream quality, shortened reach and reduced flow. To remove debris trapped in the nozzle:

- 1) Shut off flow to the nozzle.
- 2) Move the stream shaper to the wide fog position.
- 3) **For Industrial Nozzle:** Unscrew baffle using a 1-1/8 inch (28mm) socket.
For Masterstream Selectable Gallonage Nozzle: Turn flow selector on front of nozzle to "FLUSH" position.
For Masterstream Fixed Gallonage Nozzle: Remove nozzle to gain access to debris.
- 4) Remove debris. Flow water to flush if necessary.
- 5) Reassemble the nozzle. Tighten the baffle on the industrial nozzle to 30 ft-lbs (40 newton-meters).



Large amounts of debris may be unflushable and can reduce the flow of the nozzle resulting in an ineffective flow. In the event of a blockage, it may be necessary to retreat to a safe area.

5.0 MAINTENANCE

Nozzles must be checked regularly to assure proper operation. Contact factory for parts lists and exploded views for particular models.

6.0 WARRANTY

Task Force Tips, Inc., 2800 East Evans Avenue, Valparaiso, Indiana 46383 ("TFT") warrants to the original purchaser of its Industrial and Masterstream series nozzles ("equipment"), and to anyone to whom it is transferred, that the equipment shall be free from defects in material and workmanship during the five (5) year period from the date of purchase.

TFT's obligation under this warranty is specifically limited to replacing or repairing the equipment (or its parts) which are shown by TFT's examination to be in a defective condition attributable to TFT. To qualify for this limited warranty, the claimant must return the equipment to TFT, at 2800 East Evans Avenue, Valparaiso, Indiana 46383, within a reasonable time after discovery of the defect. TFT will examine the equipment. If TFT determines that there is a defect attributable to it, TFT will correct the problem within a reasonable time. If the equipment is covered by this limited warranty, TFT will assume the expenses of repair.

If any defect attributable to TFT under this limited warranty cannot be reasonably cured by repair or replacement, TFT may elect to refund the purchase price of the equipment, less reasonable depreciation, in complete discharge of its obligations under this limited warranty. If TFT makes this election, claimant shall return the equipment to TFT free and clear of any liens and encumbrances.

This is a limited warranty. The original purchaser of the equipment, any person to whom it is transferred, and any person who is an intended or unintended beneficiary of the equipment, shall not be entitled to recover from TFT any consequential or incidental damages for injury to person and/or property resulting from any defective equipment manufactured or assembled by TFT. It is agreed and understood that the price stated for the equipment is in part consideration for limiting TFT's liability. Some states do not allow the exclusion or limitation of incidental or consequential damages, so the above may not apply to you.

TFT shall have no obligation under this limited warranty if the equipment is, or has been, misused or neglected (including failure to provide reasonable maintenance) or if there have been accidents to the equipment or if it has been repaired or altered by someone else.

THIS IS A LIMITED EXPRESS WARRANTY ONLY. TFT EXPRESSLY DISCLAIMS WITH RESPECT TO THE EQUIPMENT ALL IMPLIED WARRANTIES OF MERCHANTABILITY AND ALL IMPLIED WARRANTIES OF FITNESS FOR A PARTICULAR PURPOSE. THERE IS NO WARRANTY OF ANY NATURE MADE BY TFT BEYOND THAT STATED IN THIS DOCUMENT.

This limited warranty gives you specific legal rights, and you may also have other rights which vary from state to state.

TASK FORCE TIPS, Inc. Made in USA • www.tft.com	2800 E Evans Ave • Valparaiso , IN 46383-6940 USA 800-348-2686 • 219-462-6161 • Fax 219-464-7155
---	---