



# MANUAL:

## International G-Force Nozzle

Fixed, Selectable, Automatic and Automatic with Flow Limiting

### INSTRUCTIONS FOR SAFE OPERATION AND MAINTENANCE

#### **WARNING**

Understand manual before use. Operation of this device without understanding the manual and receiving proper training is a misuse of this equipment. Obtain safety information at [www.tft.com/serial-number](http://www.tft.com/serial-number)

This Instruction Manual is intended to familiarize firefighters and maintenance personnel with the operation, servicing, and safety procedures associated with the nozzle.

This manual should be available to all operating and maintenance personnel.

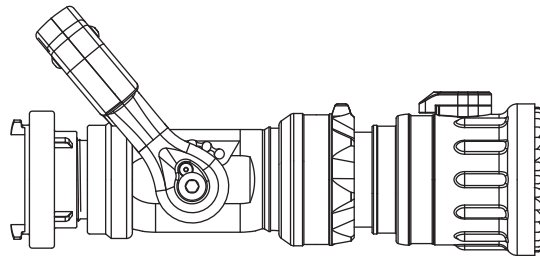

**G-Force  
with Lever Handle**

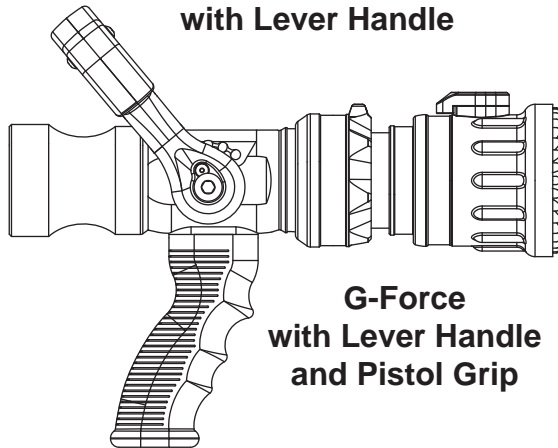

**G-Force  
with Lever Handle  
and Pistol Grip**

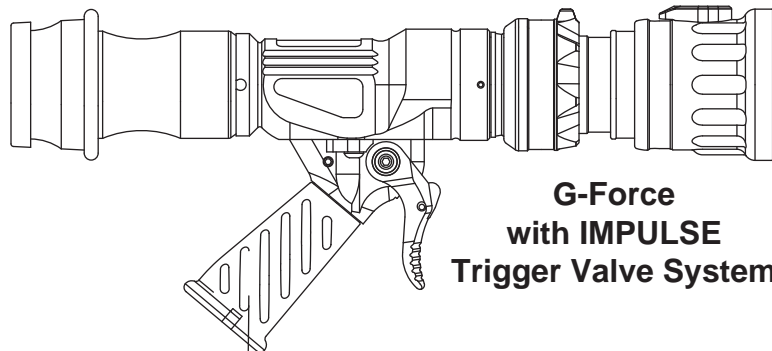

**G-Force  
with IMPULSE  
Trigger Valve System**

## Table Of Contents

- 1.0 MEANING OF SAFETY SIGNAL WORDS
- 2.0 SAFETY
- 3.0 GENERAL INFORMATION
  - 3.1 VARIOUS MODELS AND TERMS
  - 3.2 SPECIFICATIONS
    - 3.2.1 MECHANICAL
  - 3.3 NOZZLE COUPLINGS
  - 3.4 USE WITH SALT WATER
- 4.0 FLOW CHARACTERISTICS
  - 4.1 FIXED FLOW
  - 4.2 SELECTABLE FLOW
  - 4.3 AUTOMATIC
  - 4.4 AUTOMATIC WITH FLOW LIMITING
  - 4.5 EN CERTIFIED 6 BAR NOZZLE
- 5.0 NOZZLE CONTROLS
  - 5.1 FLOW CONTROL
    - 5.1.1 LEVER TYPE FLOW CONTROL
    - 5.1.2 IMPULSE TRIGGER FLOW CONTROL
    - 5.1.3 IMPULSE TRIGGER LOCK
    - 5.1.4 IMPULSE FLOW CONTROL SPEED ADJUSTMENT
    - 5.1.5 NORMAL OPERATING RANGE
  - 5.2 PATTERN AND FLUSH CONTROL
    - 5.2.1 PATTERN CONTROL
    - 5.2.2 SHAPER TACTILE INDICATOR
    - 5.2.3 SHAPER LOCK OUT LEVER
    - 5.2.4 STREAM PATTERN POSITION ADJUSTMENT
  - 5.3 FLUSH CONTROL
- 6.0 USE WITH FOAM
  - 6.1 FOAM ASPIRATING ATTACHMENTS
- 7.0 USE OF NOZZLES
- 8.0 APPROVALS
- 9.0 COLOR CODED VALVE HANDLE AND PISTOL GRIP
  - 9.1 IMPULSE TRIGGER VALVE SYSTEM NOZZLE COLORED PISTOL GRIPS
- 10.0 DRAWINGS AND PART LISTS
  - 10.1 G-FORCE NOZZLES
  - 10.2 IMPULSE TRIGGER VALVE NOZZLES
- 11.0 MAINTENANCE
  - 11.1 FIELD LUBRICATION
  - 11.2 IMPULSE TRIGGER VALVE LUBRICATION
  - 11.3 SERVICE TESTING
    - 11.2.1 HYDROSTATIC TESTING
    - 11.2.2 FLOW TESTING
    - 11.2.3 RECORDS
  - 11.4 REPAIR
- 12.0 WARRANTY
- 13.0 OPERATION and INSPECTION CHECKLIST



### PERSONAL RESPONSIBILITY CODE

The member companies of FEMSA that provide emergency response equipment and services want responders to know and understand the following:

1. Firefighting and Emergency Response are inherently dangerous activities requiring proper training in their hazards and the use of extreme caution at all times.
2. It is your responsibility to read and understand any user's instructions, including purpose and limitations, provided with any piece of equipment you may be called upon to use.
3. It is your responsibility to know that you have been properly trained in Firefighting and /or Emergency Response and in the use, precautions, and care of any equipment you may be called upon to use.
4. It is your responsibility to be in proper physical condition and to maintain the personal skill level required to operate any equipment you may be called upon to use.
5. It is your responsibility to know that your equipment is in operable condition and has been maintained in accordance with the manufacturer's instructions.
6. Failure to follow these guidelines may result in death, burns or other severe injury.



Fire and Emergency Manufacturers and Service Association  
P.O. Box 147, Lynnfield, MA 01940 • [www.FEMSA.org](http://www.FEMSA.org)

## 1.0 MEANING OF SAFETY SIGNAL WORDS

A safety related message is identified by a safety alert symbol and a signal word to indicate the level of risk involved with a particular hazard. Per ANSI standard Z535.6-2011, the definitions of the four signal words are as follows:



**DANGER** indicates a hazardous situation which, if not avoided, will result in death or serious injury.



**WARNING** indicates a hazardous situation which, if not avoided, could result in death or serious injury.



**CAUTION** indicates a potentially hazardous situation which, if not avoided, could result in minor or moderate injury.



**NOTICE** is used to address practices not related to physical injury.

SAFETY INSTRUCTIONS (or equivalent) signs indicate specific safety-related instructions of procedures.

## 2.0 SAFETY



An inadequate supply of nozzle pressure and/or flow will cause an ineffective stream and can result in injury, death, or loss of property. See flow graphs or call +1 219 548-1033 for assistance.



The nozzle may be damaged if frozen while containing significant amounts of water. Such damage may be difficult to detect visually and can lead to possible injury or death. Any time the nozzle is subject to possible damage due to freezing, it must be tested by qualified personnel before being considered safe for use.



This equipment is intended for use by trained personnel for firefighting. Their use for other purposes may involve hazards not addressed by this manual. Seek appropriate guidance and training to reduce risk of injury.



Failure to restrain nozzle reaction can cause firefighter injury from loss of footing and/or stream protection. Nozzle reaction will vary as supply conditions change: such as opening or closing other nozzles, hose line kinks, changes in pump settings, etc. Changes in spray pattern or flushing will also affect nozzle reaction. The nozzle operator must always be prepared in the event of these changes.



If nozzle gets out of control or away from operator, retreat from nozzle immediately. Do not attempt to regain control of nozzle while flowing water. Injury from whipping can occur.



Water is a conductor of electricity. Application of water on high voltage equipment can cause injury or death by electrocution. The amount of current that may be carried back to the nozzle will depend on the following factors:

- Voltage of the line or equipment
- Distance from the nozzle to the line or equipment
- Size of the stream
- Whether the stream is solid or broken
- Purity of the water<sub>1</sub>

<sup>1</sup> The Fire Fighter and Electrical Equipment, The University of Michigan Extension Service, Fourth Printing 1983. Page 47



Fire streams are capable of injury and damage. Do not direct water stream to cause injury or damage to persons or property.

### 3.0 GENERAL INFORMATION

The Task Force Tips G-Force nozzles are designed to provide excellent performance under most fire fighting conditions. Their rugged construction is compatible with the use of fresh water (see section 3.4 for saltwater use) as well as fire fighting foam solutions.

### 3.1 VARIOUS MODELS AND TERMS

The G-Force nozzle is available in several different models and inlet connections. Basic body styles are shown in figure 3.1A

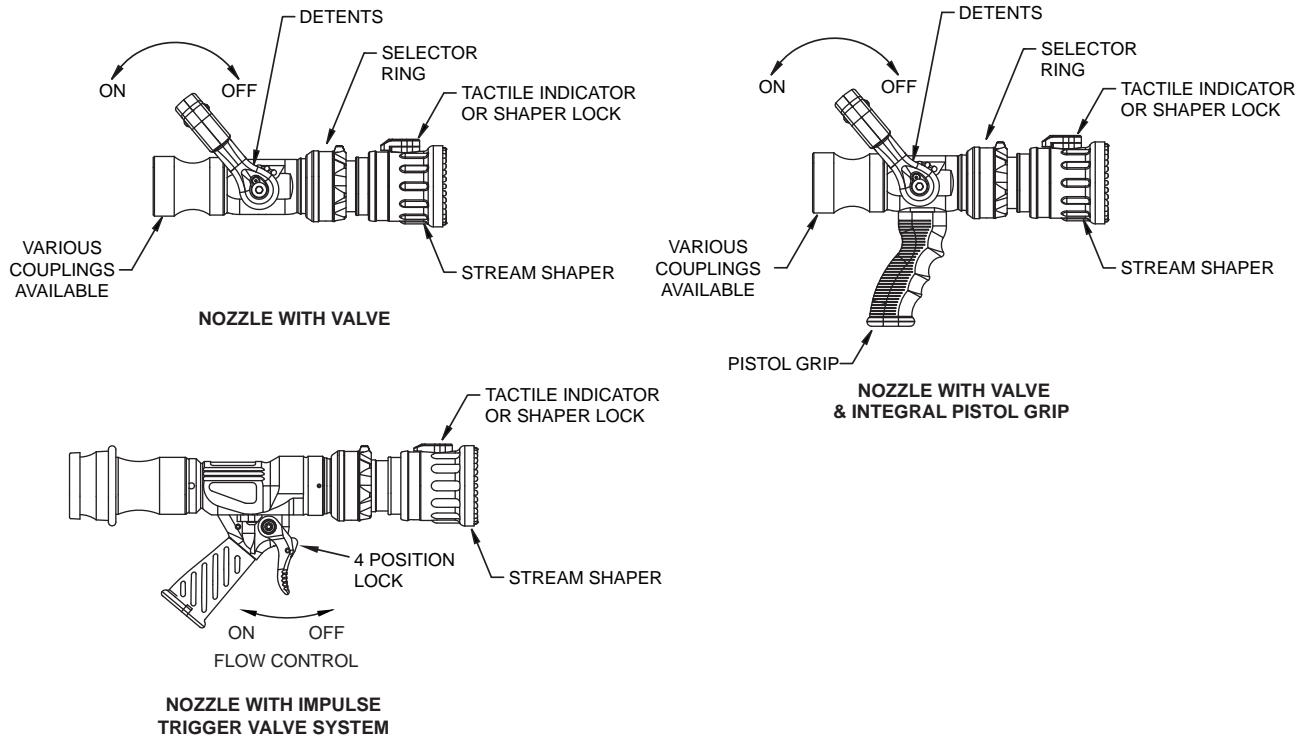

Other options are:

- Fixed rubber, fixed aluminum or stainless steel spinning fog teeth.
- Shaper tactile indicator with or without detent (see section 5.2.2)
- Shaper lock out lever (see section 5.2.3)

Four flow options are available. All four use the selector ring for flush control. The flow options are:

- Fixed flow (see section 4.1)
- Selectable flow (see section 4.2)
- Automatic (see section 4.3)
- Automatic with Flow Limiting (see section 4.4)

### 3.2 SPECIFICATIONS

#### 3.2.1 MECHANICAL

	1.5" MODEL	1.0" MODEL	1.5" MODEL	1.0" IMPULSE
Maximum operating pressure (with valve shut off)	370 psi	580 PSI	25.5 bar	40.0 bar
Operating temperature range of fluid	33 to 120° F		1 to 50° C	
Storage temperature range	-40 to 150° F		-40 to 65° C	
Materials used	Aluminum 6000 series hard anodized MIL8625 class 3 type 2, stainless steel 300 series, nylon 6-6, nitrile rubber			

### 3.3 NOZZLE COUPLINGS

Many inlet couplings such as NH (National Hose) or BSP (British Straight Pipe) can be specified at time of order.



Nozzle must be mated to a hose line with matched threads. Mismatched or damaged threads may cause nozzle to leak or uncouple under pressure and could cause injury.



Dissimilar metals coupled together can cause galvanic corrosion that can result in the inability to unscrew the threads or complete loss of thread engagement over time. Per NFPA 1962, if dissimilar metals are left coupled together an anti-corrosive lubricant should be applied to the threads. Also the coupling should be disconnected and inspected at least quarterly.

### 3.4 USE WITH SALT WATER

Use with saltwater is permissible provided nozzle is thoroughly cleaned with fresh water after each use. The service life of the nozzle may be shortened due to the effects of corrosion and is not covered under warranty.

## 4.0 FLOW CHARACTERISTICS

### 4.1 FIXED FLOW

A fixed flow G-Force nozzle has one fixed discharge orifice and a flush setting. A fixed flow G-Force is flush able with the selector ring. Figure 4.2 shows flow and pressure graphs for the G-Force Fixed nozzles.

### 4.2 SELECTABLE FLOW

A selectable G-Force nozzle has several fixed discharge orifices and a flush setting. A particular orifice is selected by rotating the selector ring. Figure 4.2 shows flow and pressure graphs for the G-Force Selectable nozzles.

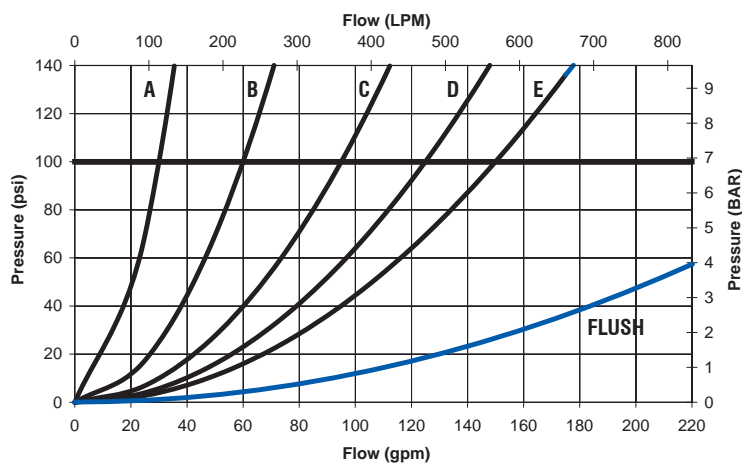

#### FIXED GALLONAGE



#### SELECTABLE GALLONAGE

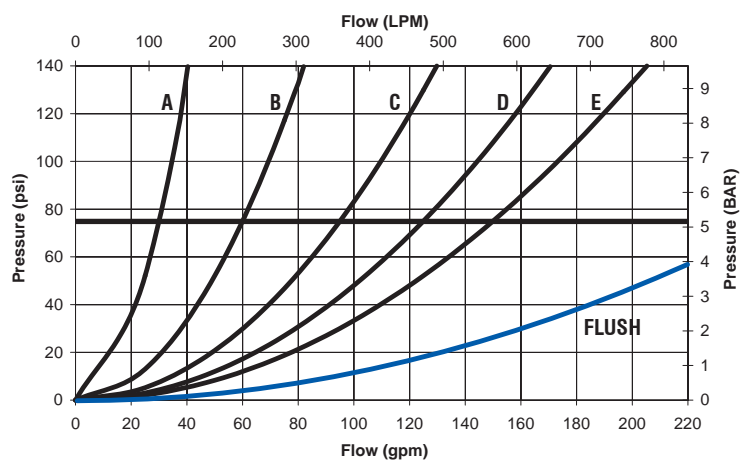
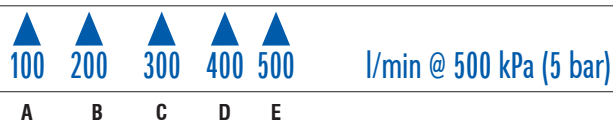

#### FIXED GALLONAGE



#### SELECTABLE GALLONAGE



Figure 4.2 G-Force Fixed and Selectable Nozzle Flow Charts

### 4.3 AUTOMATIC

The G-Force is available with automatic pressure control and flush setting. Flow range and performance is shown in figure 4.3.

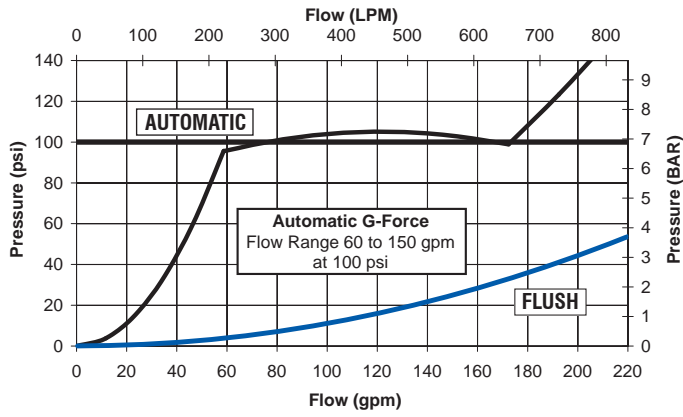

230 - 570 l/min @ 700 kPa (7 bar)    **AUTOMATIC**    60-150 GPM @ 100 PSI

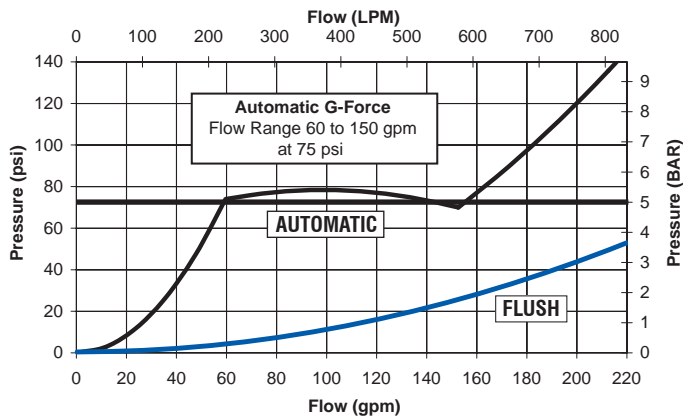

230 - 570 l/min @ 500 kPa (5 bar)    **AUTOMATIC**    60-150 GPM @ 75 PSI

Figure 4.3 G-Force Automatics

## 4.4 AUTOMATIC WITH FLOW LIMITING

The Automatic G-Force with flow limiting gives the utmost in flexibility. Settings on the selector ring change the automatic nozzle's maximum opening so that water can be conserved (with a small maximum opening). There are also selections that increase the nozzle's initial opening so a larger amount of water can be flowed at low pressure and flush setting. Figure 4.4. shows the performance of the G-Force Automatic with flow limiting, at low pressure and a flush setting.

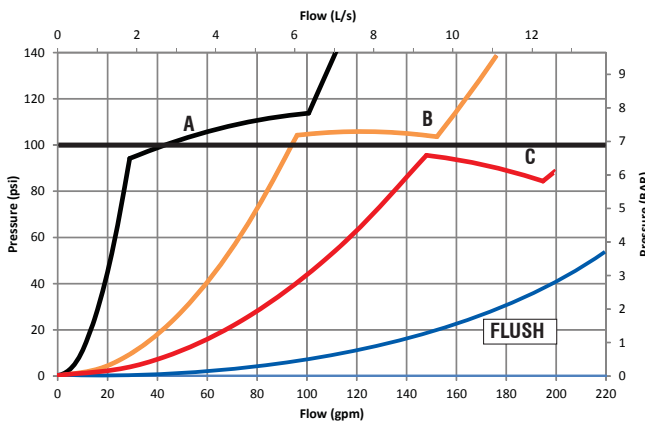
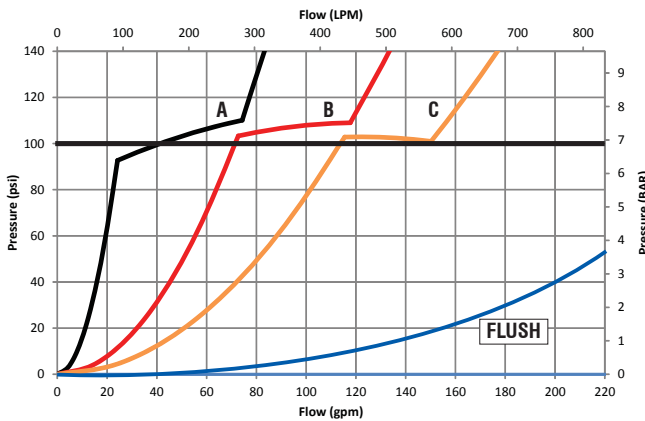
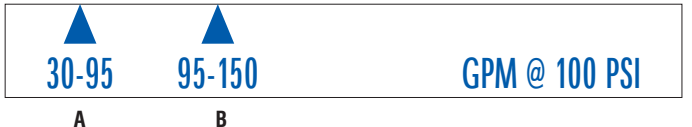
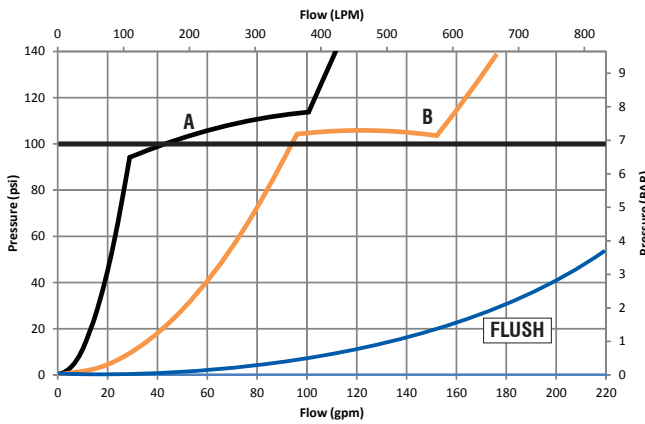
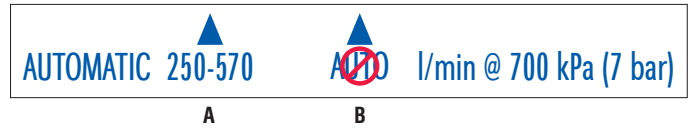
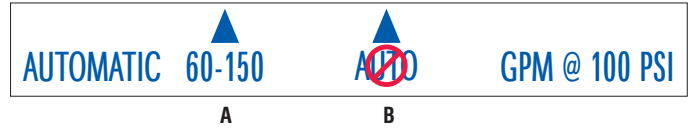
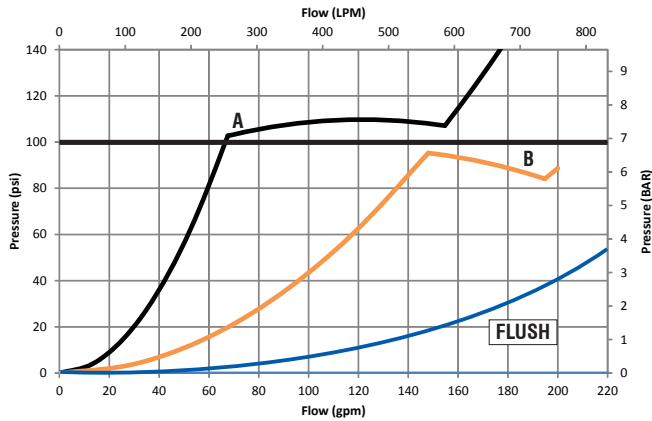

#### 4.4 AUTOMATIC WITH FLOW LIMITING (continued)

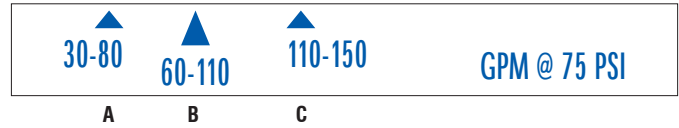
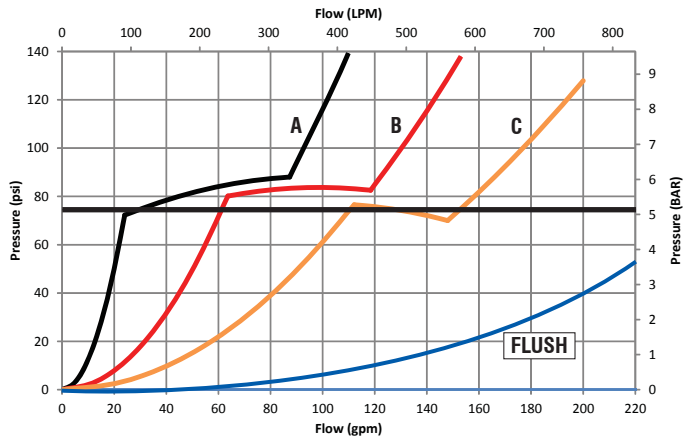
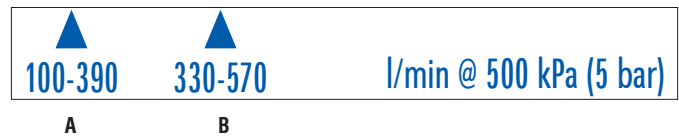
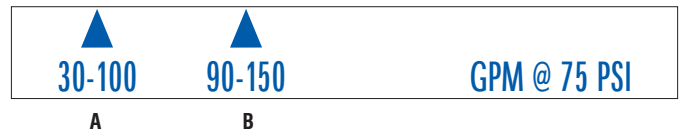
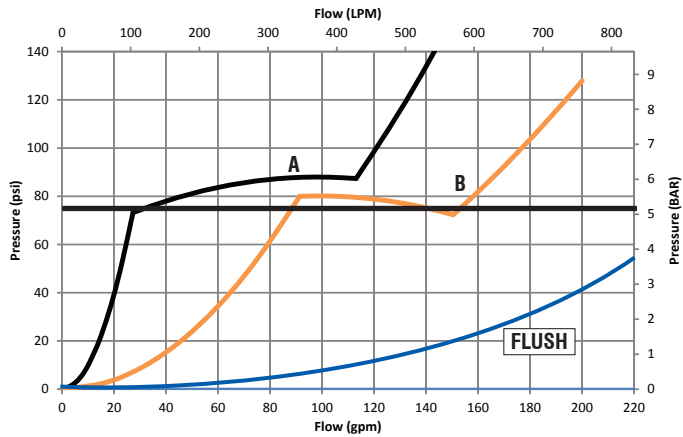
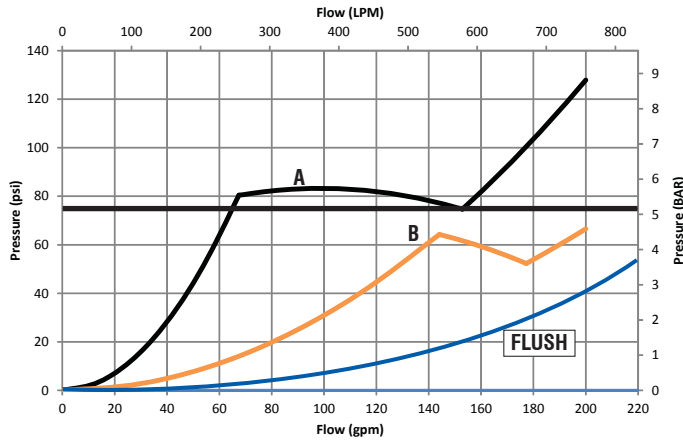

Figure 4.4 G-Force Automatic With Flow Limiting

#### 4.5 EN CERTIFIED 6 BAR NOZZLES

For flow and pressure graphs of G-Force 6 bar (87 psi) nozzles, see the EN Certification section in the [www.tft.com](http://www.tft.com) library.



## 5.0 NOZZLE CONTROLS

Nozzle control valves must be opened slowly to eliminate unnecessary strain on the hose and couplings and reduce pressure surges. Nozzles attached to an in-service hose shall be stored in the off position.

### 5.1 FLOW CONTROL

#### 5.1.1 LEVER TYPE FLOW CONTROL

On models that use a lever type valve handle, the nozzle is shut off when the handle is fully forward. The valve handle has 5 detented flow positions. These detent positions allow the nozzle operator to regulate the flow of the nozzle depending on the need or what can be safely and effectively handled. TFT recommends the use of a pistol grip for easier handling. For additional stress reduction, a hose rope or strap may also be used. This permits more effective use and ease of advancement, while minimizing strain and fatigue.

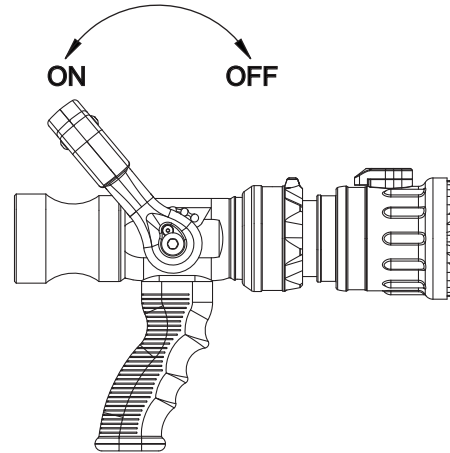

#### 5.1.2 IMPULSE TRIGGER FLOW CONTROL

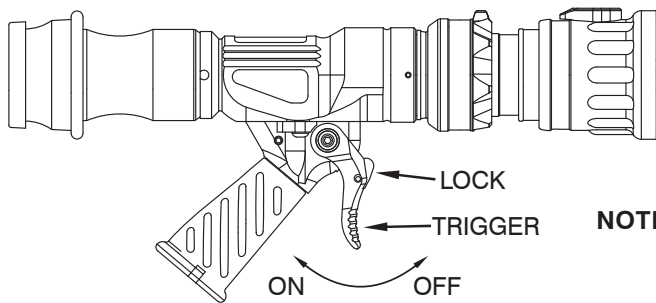

**NOTE: THE TRIGGER RETURNS TO OFF IF NOT HELD OR LOCKED**

### **WARNING**

Do not intentionally release the nozzle while flowing and trust the valve to shut off automatically. The trigger nozzle's ability to shut off by itself represents an extra level of safety when following normal nozzle handling procedures. To rely on it as the sole means of safety increases the risk of injury from an out of control nozzle. Release nozzle when flow has stopped.

#### 5.1.3 IMPULSE TRIGGER LOCK

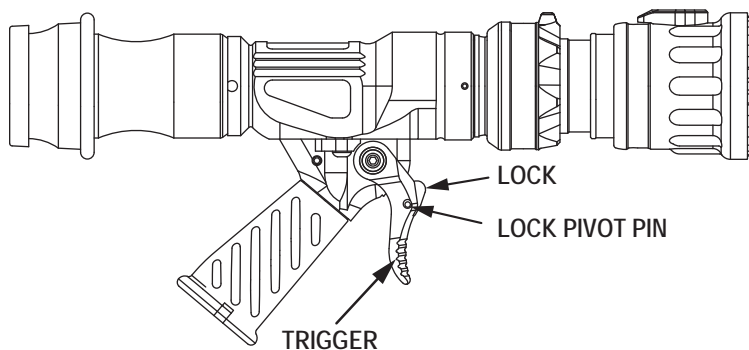

**To Lock:** Push on the lock while pulling back the trigger to engage one of the four locked positions.

**To Un-Lock:** Pull back slightly on trigger without any pressure on the lock. The spring loaded lock should automatically move to the unlocked position.

Use an 1/8" (3mm) punch to push out pin and remove lock if the lock is not desired.

### **WARNING**

When the trigger lock is engaged, the nozzle will not shut off if dropped. Always shut off nozzle before releasing the pistol grip to avoid injury from an out of control nozzle.

### 5.1.4 TRIGGER FLOW CONTROL SPEED ADJUSTMENT

The IMPULSE valve contains a slow close mechanism to prevent the nozzle from slamming off if the trigger is suddenly released. The closing speed is set at the factory to be slow enough to reduce water hammer, ("water hammer" is always present in any valve when it is shut off. The slow close mechanism will reduce this but cannot eliminate it completely) but fast enough to reduce the potential danger of hose whipping from a dropped nozzle. The closing speed may be adjusted as shown in the figure.5.1.4

**Note:** The High Pressure 1 inch (25 mm) models do not have the slow close feature. They are often used in pulsing applications and need to close quickly.

Do not unscrew the adjuster past the end of the hand grip (to unscrew it too far could result in the loss of dampening fluid).

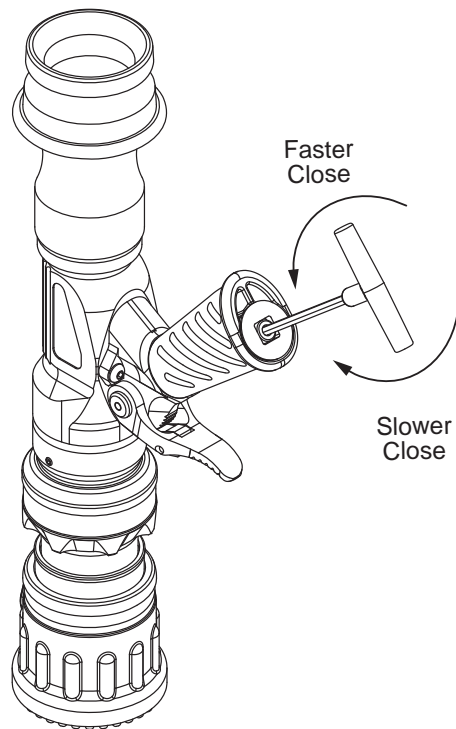
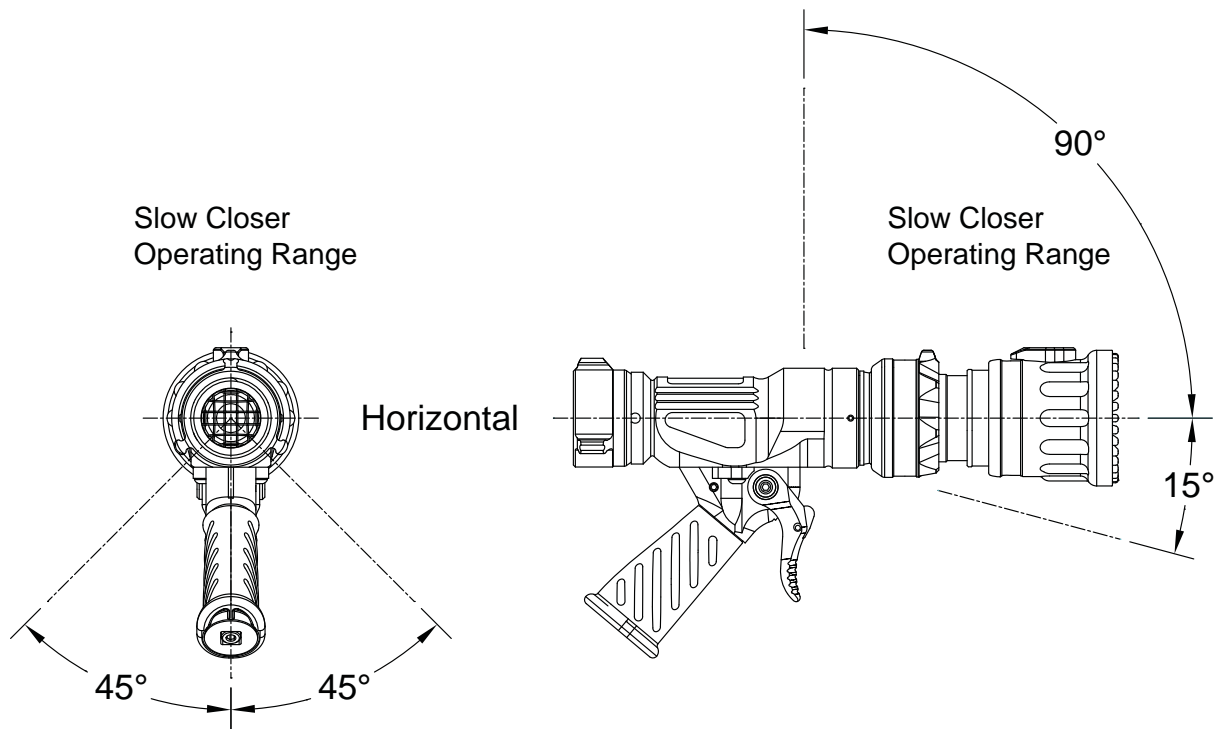

Figure 5.1.4

**WARNING** As the closing time is increased so does the risk of injury from an out of control nozzle. A flowing nozzle can cause injury within the first second of lost control. Use caution when adjusting the closing speed and always verify performance after adjustment.

### 5.1.5 NORMAL OPERATING POSITION



**WARNING** The Slow Close Feature relies on a fluid and air combination in the pistol grip. For proper function, the pistol grip should be within its normal operating position. The normal operating position is with the nozzle horizontal or pointing up with the pistol grip within 45 degrees of vertical. Releasing the trigger suddenly outside of the normal orientation will likely result in faster shut-off causing a higher pressure spike and increasing the risk of a burst hose. Do not suddenly release the trigger when operating outside of the nozzle's normal orientation.

## 5.2 PATTERN AND FLUSH CONTROL

### 5.2.1 PATTERN CONTROL

TFT's nozzles have full pattern control from straight stream to wide fog. Turning the stream shaper clockwise (as seen from the operating position behind the nozzle) moves the shaper to the straight stream position. Turning the shaper counterclockwise will result in an increasingly wider pattern.

Since the stream trim point varies with flow, the stream should be "trimmed" after changing the flow to obtain the straightest and farthest reaching stream. To properly trim the stream, first open the pattern to narrow fog. Then close the stream to parallel to give maximum reach. **Note: Turning the shaper further forward will cause stream crossover and reduce the effective reach of the nozzle.**

The nozzle reaction is greatest when the shaper is in the straight stream position. The nozzle operator must be prepared for a change in reaction as the pattern is changed.

Care must be taken to avoid dents or nicks in the nozzle tip because they can seriously affect the stream reach.

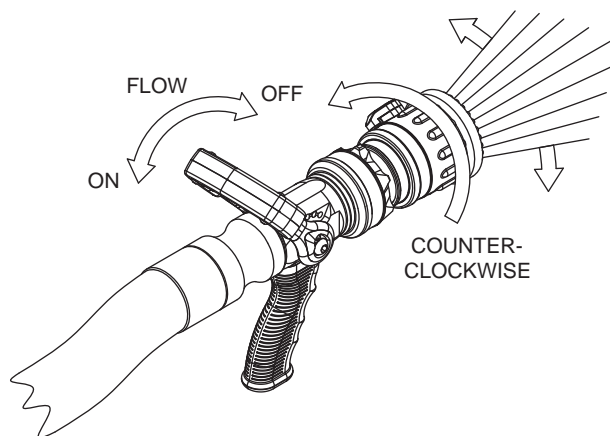
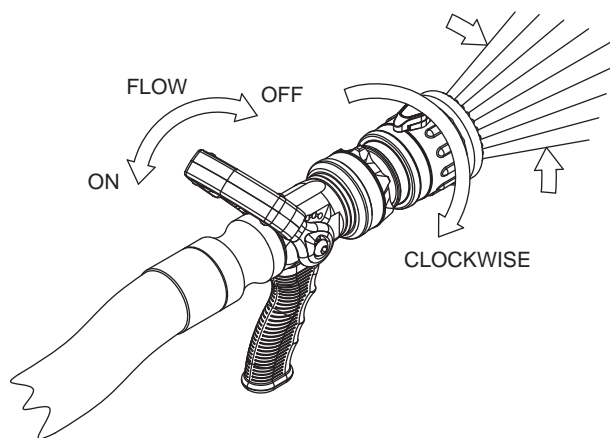

### 5.2.2 SHAPER TACTILE INDICATOR

The G-Force has a tactile indicator on the stream shaper. The tactile indicator allows the stream shaper position (and fog angle) to be determined by feel rather than by sight. The fog angle can be adjusted (see section 5.2.4) so that a desired fog angle is achieved when the tactile indicator is on top of the nozzle. The G-Force has an optional detent to aid in returning to a known fog angle. Note: The fog angle will change as flow and pressure change (becoming wider with increased flow).

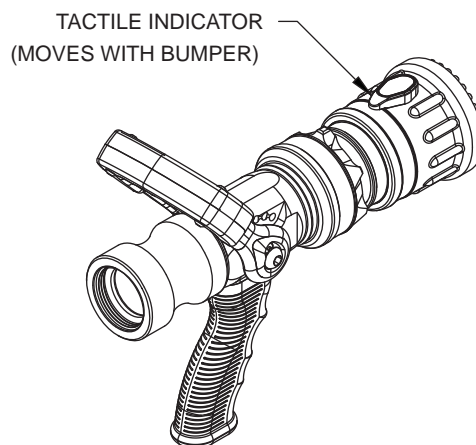

### 5.2.3 SHAPER LOCK OUT LEVER

The G-Force has an optional shaper lock out lever that locks the shaper in a set position. Various stream patterns are possible. User can specify with order. If not specified, default position at partial fog. When locked, the lever will be on top of the nozzle. Moving a lever unlocks the shaper for normal pattern adjustment. When rotating the shaper, the shaper will automatically become locked when the lock out lever moves to the top of the nozzle.

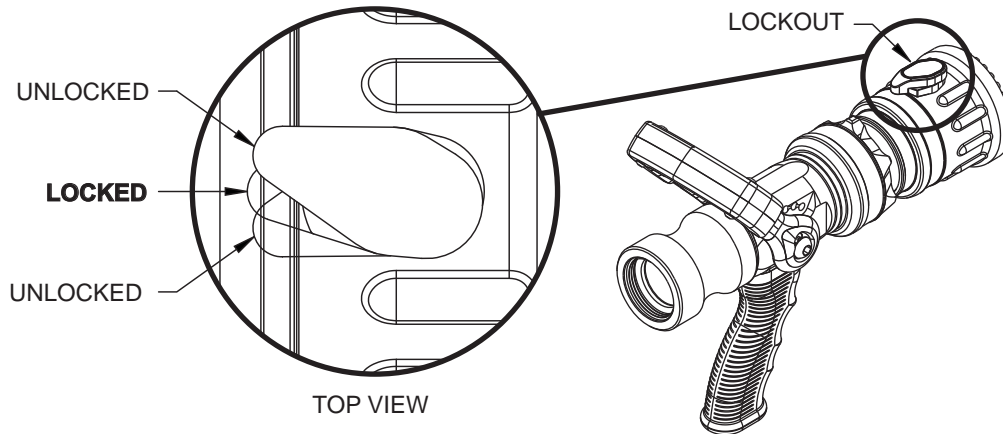

### 5.2.4 STREAM PATTERN POSITION ADJUSTMENT

Typically the G-Force is factory set with the tactile indicator or lock out lever in the top position for a partial fog stream pattern. The stream pattern can be adjusted while keeping the tactile indicator or lock out lever on top by following the steps in figure 5.2.4:

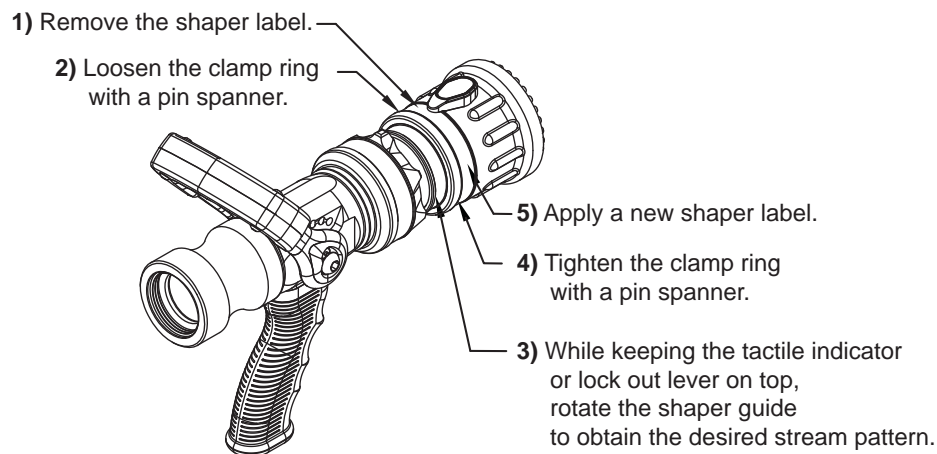
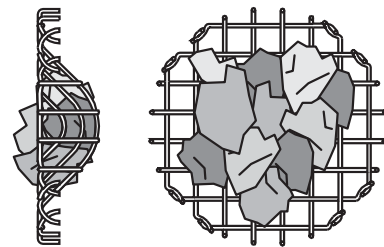

Figure 5.2.4 Stream Pattern Adjustment

### 5.3 FLUSH CONTROL

Small debris passes through the debris screen (if equipped) and may get caught inside the nozzle. This trapped material will cause poor stream quality, shortened reach, and reduced flow. To remove small debris, the nozzle may be flushed as follows:

- While still flowing water, rotate the index ring counterclockwise (as viewed from behind the nozzle) to the flush position. (increased resistance will be felt on the RING as the nozzle goes into flush) This will open the nozzle allowing debris to pass through.
- During flush the nozzle reaction will decrease as the nozzle orifice increases and the pressure drops. The nozzle operator must be prepared for an increase of nozzle reaction when returning the nozzle from the flush position to retain control of the nozzle.
- Rotate the selector ring out of flush to continue normal operations.



**Large amounts or pieces of debris may be unflushable and can reduce the flow of the nozzle resulting in an ineffective flow. In the event of a blockage, it may be necessary to retreat to a safe area, uncouple the nozzle and remove debris.**

## 6.0 USE WITH FOAM

The G-Force nozzle may be used with foam solutions. Refer to fire service training for the proper use of foam.

### WARNING

For Class B fires, lack of foam or interruption in the foam stream can cause a break in the foam blanket and greatly increase the risk of injury or death. Assure that:

- Application rate is sufficient (see NFPA 11 or foam manufacturer's recommendations)
- Enough concentrate is on hand to complete task (see NFPA for minimum duration time requirements)
- Foam logistics have been carefully planned.

Allow for such things as:

- Storage of foam in a location not exposed to the hazard it protects
- Personnel, equipment and technique to deliver foam at a rapid enough rate
- Removal of empty foam containers
- Clear path to deliver foam, as hoses and other equipment and vehicles are deployed

### WARNING

Improper use of foam can result in injury or damage to the environment. Follow foam manufacturer's instructions and fire service training to avoid:

- Using wrong type of foam on a fire. i.e. Class A foam on a Class B fire.
- Plunging foam into pools of burning liquid fires.
- Causing environmental damage.
- Directing stream at personnel.

### WARNING

There are a wide variety of foam concentrates. Each user is responsible for verifying that any foam concentrate chosen to be used with this unit has been tested to assure that the foam obtained is suitable for the purpose intended.

### WARNING

Use of compressed air foam (CAF) with hand held nozzles can cause sudden surges in nozzle reaction force resulting in risk of injury or death from loss of footing or hose whipping. Be prepared for sudden changes in nozzle reaction caused by:

- Slug loading (Loss of foam concentrate sends slugs of air and water into the nozzle)
- Sudden release of built-up pressure in the hose when opening a nozzle

## 6.1 FOAM ASPIRATING ATTACHMENTS

To increase the expansion ratio, G-Force Series MX Foamjet (model FJ-MX-G) multi-expansion attachment or LX Foamjet (model FJ-LX-G) low expansion attachment may be used with G-Force nozzles. These foam tubes attach and detach quickly from the nozzle. Note: As expansion ratio is increased, the reach of the nozzle will be decreased due to the greater amount of bubbles in the stream and their ability to penetrate the air. Generally the reach with foam is approximately 10% less than with water only. Actual results will vary based on brand of foam, hardness of water, temperature, etc. See Foamjet instruction manual for specific information. See LIA-025 (MANUAL: Foam Attachments for TFT Nozzles).

## 7.0 USE OF NOZZLES

IT IS THE RESPONSIBILITY OF THE INDIVIDUAL FIRE DEPARTMENT OR AGENCY TO DETERMINE PHYSICAL CAPABILITIES AND SUITABILITY FOR AN INDIVIDUAL'S USE OF THIS EQUIPMENT.

Many factors contribute to the extinguishment of a fire. Among the most important is delivering water at a flow rate sufficient to absorb heat faster than it is being generated. The flow rate depends largely on the pump discharge pressure and hose friction loss. It can be calculated using a hydraulic equation such as:

$$PDP = NP + FL + DL + EL$$

**PDP** = Pump discharge pressure in PSI

**NP** = Nozzle pressure in PSI

**FL** = Hose friction loss in PSI

**DL** = Device loss in PSI

**EL** = Elevation loss in PSI

This manual is not intended to act as a training guide for safe fireground tactics and operations. For additional information visit [www/tft.com](http://www/tft.com) or contact customer service at 800-348-2686.

## 8.0 APPROVALS

Many TFT G-Force nozzle configurations carry the FM rating, NFPA certification, or EN certification. Consult [www.tft.com](http://www.tft.com) for a complete list.

## 9.0 COLOR CODED VALVE HANDLE AND PISTOL GRIP

The TFT G-FORCE with lever type valve handles are supplied with black valve handle covers and pistol grips. The handle covers and pistol grips are available from TFT in various colors for those departments wishing to color code the nozzle to the discharge controls. A colored handle cover set will be sent upon receipt of the warranty card by TFT. Your department's name can also be engraved on the covers (see warranty card for more information).

Handle covers are replaceable by removing the four screws that hold the handle covers in place. Use a 3/32" allen wrench when replacing screws. Pistol grip is replaceable by following TFT instruction sheet LTT-108.

For standardization NFPA 1901 (A-4-9.3) recommends the following color code scheme:

Preconnect #1 or Bumper Jump Line	Orange	Other Colors Available:
Preconnect or discharge #2	Red	• Gray
Preconnect or discharge #3	Yellow	• Pink
Preconnect or discharge #4	White	• Purple
Preconnect or discharge #5	Blue	• Tan
Preconnect or discharge #6	Black	
Preconnect or discharge #7	Green	
Foam Lines	Red w/ White border (Red/White)	

### 9.1 IMPULSE TRIGGER VALVE SYSTEM NOZZLE COLORED PISTOL GRIPS

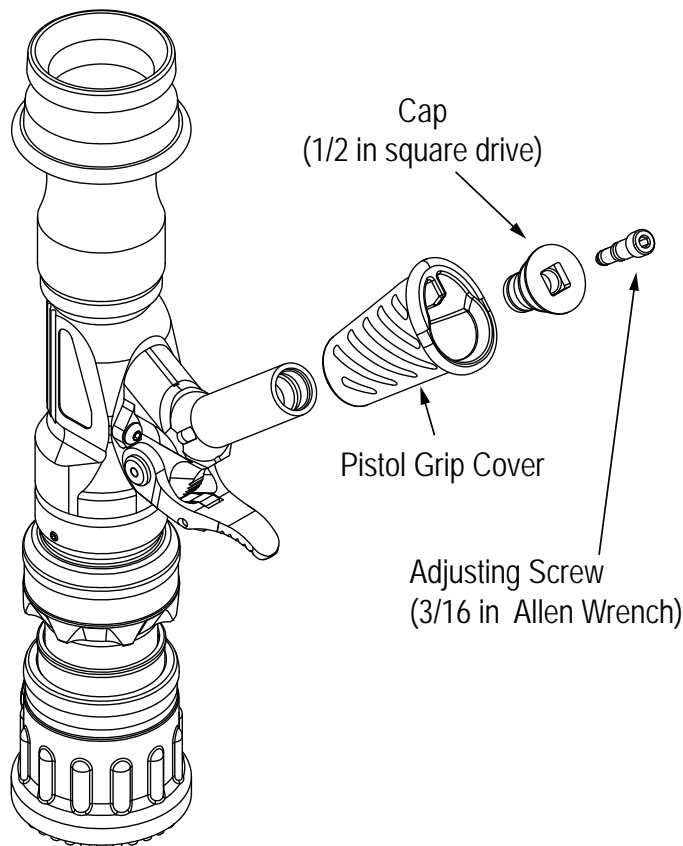

The TFT Impulse Trigger Valve System nozzles are supplied with black pistol grip covers. The pistol grip covers are available from TFT in various colors for those departments wishing to color code the nozzle to the discharge controls. Follow the steps below to change the pistol grip cover.

- 1) Orient nozzle vertically. This keeps the dampening fluid in the pistol grip from spilling out.
- 2) Remove the Cap. (1/2 in square drive) The Adjusting Screw (3/16 in Allen Wrench) may need to be turned in or removed to be able to engage the square pocket in the cap. Note the position of the Adjusting Screw before moving it.
- 3) Slide off the Pistol Grip Cover and install a new one. Be sure the Pistol Grip Cover's internal rib is toward the back of the nozzle.
- 4) Reinstall the Cap until it bottoms out on its shoulder.
- 5) Reinstall or reposition the Adjusting Screw if it has been moved from its original location.
- 6) Flow nozzle to check performance of slow closer. Adjust as needed (see section 5.1.4).



# 10.0 DRAWINGS AND PART LISTS

## 10.1 G-FORCE NOZZLES

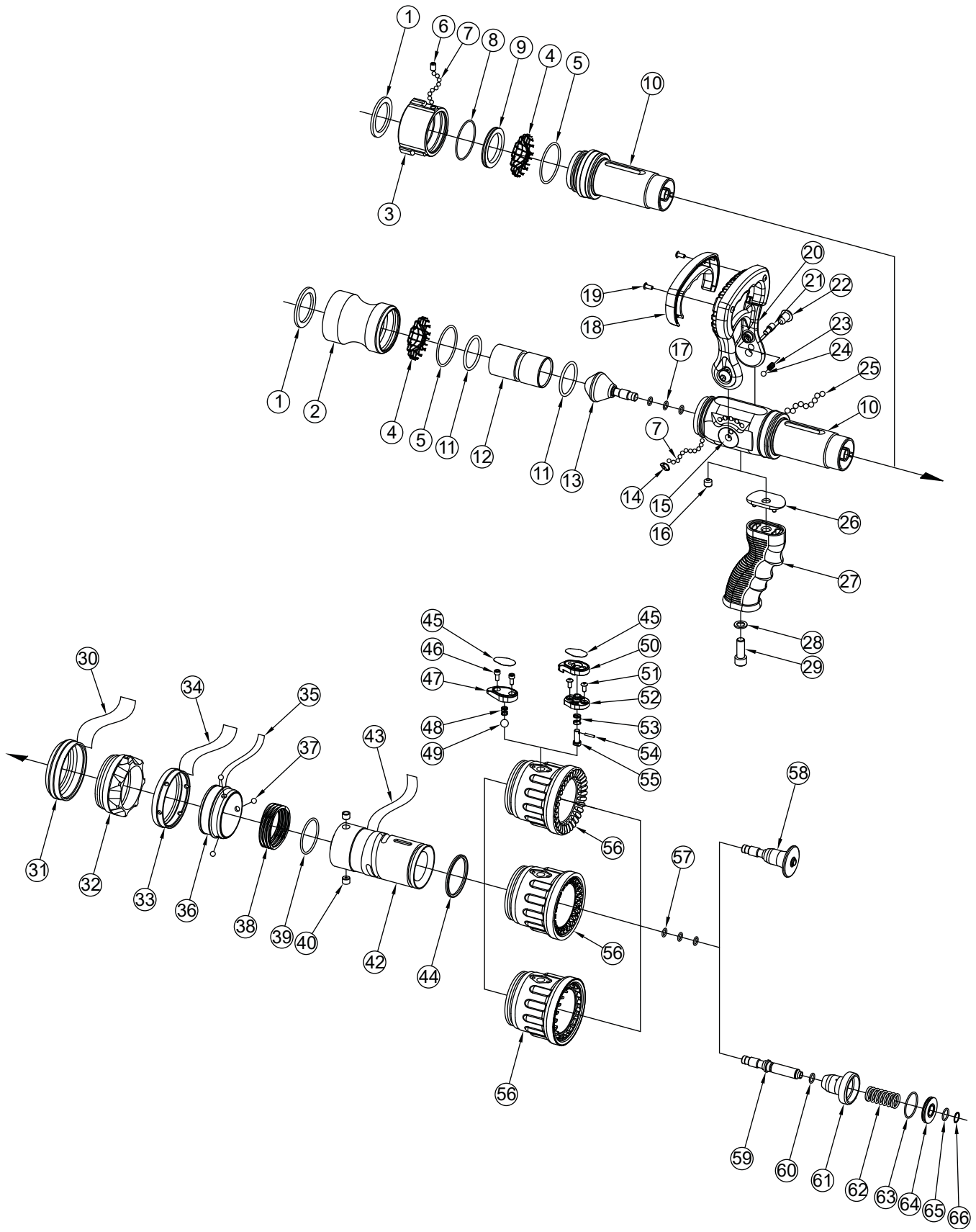

#	DESCRIPTION	QTY	PART #
1	GASKET 1.5"	1	V3130
2	COUPLING 1.5"BSPF STRETCH	1	G691B
	COUPLING 1.5"NHF		G690*
	SWIVEL 2.0"BSPM		G693
	SWIVEL 2.5"BIC MALE		G694
3	COUPLING NFTS 1.5"F	1	G698*
4	GASKET GRABBER	1	G606
5	O-RING-134	1	VO-134
6	1/4-28 X 3/8 SOCKET SET SCREW	1	VT25-28SS375
7	3/16" SS BALL	34	V2120
8	O-RING-032	1	VO-032
9	NFTS ADAPTER	1	G602
10	VALVE BODY	1	G600
	TIP ONLY BASE		G601
11	O-RING-222	2	VO-222
12	SLIDER	1	G605
13	VALVE PLUG SUBASSEMBLY	1	G903
14	PORT PLUG	1	B770
15	DISK	2	G615
16	3/8-16 X 5/16 SOCKET SET SCREW	1	VT37-16SS312
17	O-RING-011	3	VO-011
18	HANDLE COVER, BLACK	2	HM625
19	8-14 X 3/8 PUSH TITE BUTTON HEAD	4	VT08-14PT375
20	VALVE HANDLE	1	G620
21	CAM PIN	2	G616
22	HANDLE SCREW	2	HM645
23	DETENT SPRING	2	HM770
24	.243" TORLON BALL	2	VB243TO
25	1/8" ACETAL BALL	56	VB125AC
26	GRIP SPACER F100	1	HM693-F
27	PISTOL GRIP, BLACK	1	HM692-BLK
28	WASHER	1	VM4901
29	3/8-16 X 1 SOCKET HEAD SCREW	1	VT37-16SH1.0
30	INDEX RING LABEL - 30/60/95/125/150GPM @ 100PSI	1	G641S0L
	INDEX RING LABEL - 110/230/360/470/570 LPM 700 KPA		G641S0LM
	INDEX RING LABEL - 30/60/95/125/150 GPM @ 75 PSI		G641S1L
	INDEX RING LABEL - 110/230/360/470/570 LPM 500 KPA		G641S1LM
	INDEX RING LABEL - 100/200/300/400/500 LPM 500 KPA		G641S2LM
	INDEX RING LABEL - 150 GPM @ 100 PSI		G641S5L
	INDEX RING LABEL - 150 GPM @ 75 PSI		G641S6L
	INDEX RING LABEL - AUTOMATIC		G641A0L
	INDEX RING LABEL - AUTOMATIC		G641A1L
	INDEX RING LABEL - PULSING 0/100/150 LPM, AUTO 250, 6 BAR		G641L5L
	INDEX RING LABEL - AUTO 7 BAR 100-360, 360-570 LPM		G641L5LM
	INDEX RING LABEL - AUTO 75 PSI 30-100, 90-150 GPM		G641L6L
	INDEX RING LABEL - AUTO 5 BAR 100-390, 330-570 LPM		G641L6LM
	INDEX RING LABEL - AUTO 100 PSI 30-70, 70-110, 110-150 GPM		G641L7L
	INDEX RING LABEL - AUTO 7 BAR 100-270, 270-430, 430-570 LPM		G641L7LM
	INDEX RING LABEL - AUTO 75 PSI 30-80, 60-110, 110-150 GPM		G641L8L
	INDEX RING LABEL - AUTO 5 BAR 100-300, 240-430, 420-570 LPM		G641L8LM
	INDEX RING LABEL - AUTO 100 PSI 60-150 GPM, LOW (150 I.O.)		G641L9L
	INDEX RING LABEL - AUTO 7 BAR 250-570 LPM, LOW (570 I.O.)		G641L9LM
	INDEX RING LABEL - AUTO 75 PSI 60-150 GPM, LOW (150 I.O.)		G641L10L
	INDEX RING LABEL - AUTO 5 BAR 240-570 LPM, LOW (570 I.O.)		G641L10LM
31	SUBRING	1	G640
32	INDEX RING - 30/60/95/125/150 GPM @ 100 PSI	1	G641S0
	INDEX RING - 30/60/95/125/150 GPM @ 75 PSI		G641S1
	INDEX RING - AUTOMATIC		G641A0
	INDEX RING - AUTO 360/570 LPM @ 700 KPA		G641L5
	INDEX RING - AUTO 390/570 LPM @ 500 KPA		G641L6
	INDEX RING - AUTO 270/430/570 LPM @ 700 KPA		G641L7
	INDEX RING - AUTO 300/430/570 LPM @ 500 KPA		G641L8
	INDEX RING - AUTO 250/570 LPM LOW 700 KPA		G641L9
	INDEX RING - AUTO 240/570 LPM LOW 500 KPA		G641L10

#	DESCRIPTION	QTY	PART #
33	CLAMP RING	1	G656
34	CLAMP RING LABEL: G-FORCE - BLUE	1	G656L-B
	CLAMP RING LABEL: G-FORCE - GREY		G656L-G
	CLAMP RING LABEL: G-FORCE - BLACK		G656L-K
35	SHAPER GUIDE LABEL: G-FORCE - BLUE	1	G655L-B
	SHAPER GUIDE LABEL: G-FORCE - GRAY		G655L-G
	SHAPER GUIDE LABEL: G-FORCE - BLACK		G655L-K
36	SHAPER GUIDE	1	G655
37	.243" TORLON BALL	3	VB243TO
38	FLUSH SPRING	1	G626
39	O-RING-130	1	VO-130
40	CAM	2	G624
42	BARREL, SHAPER LOCK-OUT	1	G627
43	BARREL LABEL: G-FORCE - BLUE	1	G625L-B
	BARREL LABEL: G-FORCE - GRAY		G625L-G
	BARREL LABEL: G-FORCE - BLACK		G625L-K
44	QUAD-RING-225	1	VOQ-4225
45	TACTILE INDICATOR OR LEVER LABEL - BLUE	1	G657L-B
	TACTILE INDICATOR OR LEVER LABEL - GRAY		G657L-G
	TACTILE INDICATOR OR LEVER LABEL - BLACK		G657L-K
46	8-32 X 3/8 SOCKET HEAD SCREW	2	VT08-32SH375
47	TACTILE INDICATOR	1	G657
48	DETENT SPRING	1	H770
49	3/8" TORLON BALL	1	VB375TO
50	SHAPER LATCH LEVER	1	G659
51	8-32 X 3/8 BUTTON HEAD SCREW	2	VT08-32BH375
52	SHAPER LATCH BASE	1	G658
53	SPRING	1	G662
54	DOWEL PIN	1	VP094X.50
55	LOCK PIN	1	G660
56	FIXED RUBBER TEETH SHAPER WITH BUMPER	1	G650
	FIXED METAL TOOTH BUMPER SUBASSEMBLY		G954
	SPINNING TOOTH BUMPER SUBASSEMBLY		G905
57	QUAD-RING-011	3	VOQ-4011
58	FIXED BAFFLE	1	G630
59	AUTOMATIC SHAFT	1	G633
60	O-RING-012	1	VO-012
61	AUTOMATIC BAFFLE	1	G632
62	CONTROL SPRING 100 PSI	1	G635-100
	CONTROL SPRING 75 PSI / 5 BAR		G635-75
63	O-RING-025	1	VO-025
64	75 PSI SUBBAFFLE	1	G634-75
	100 PSI SUBBAFFLE		G634-100
65	O-RING-014	1	VO-014
66	SMALLEY RING	1	VR4225

\* - CONSULT FACTORY FOR SPECIAL THREADS



## 10.2 IMPULSE TRIGGER VALVE NOZZLES

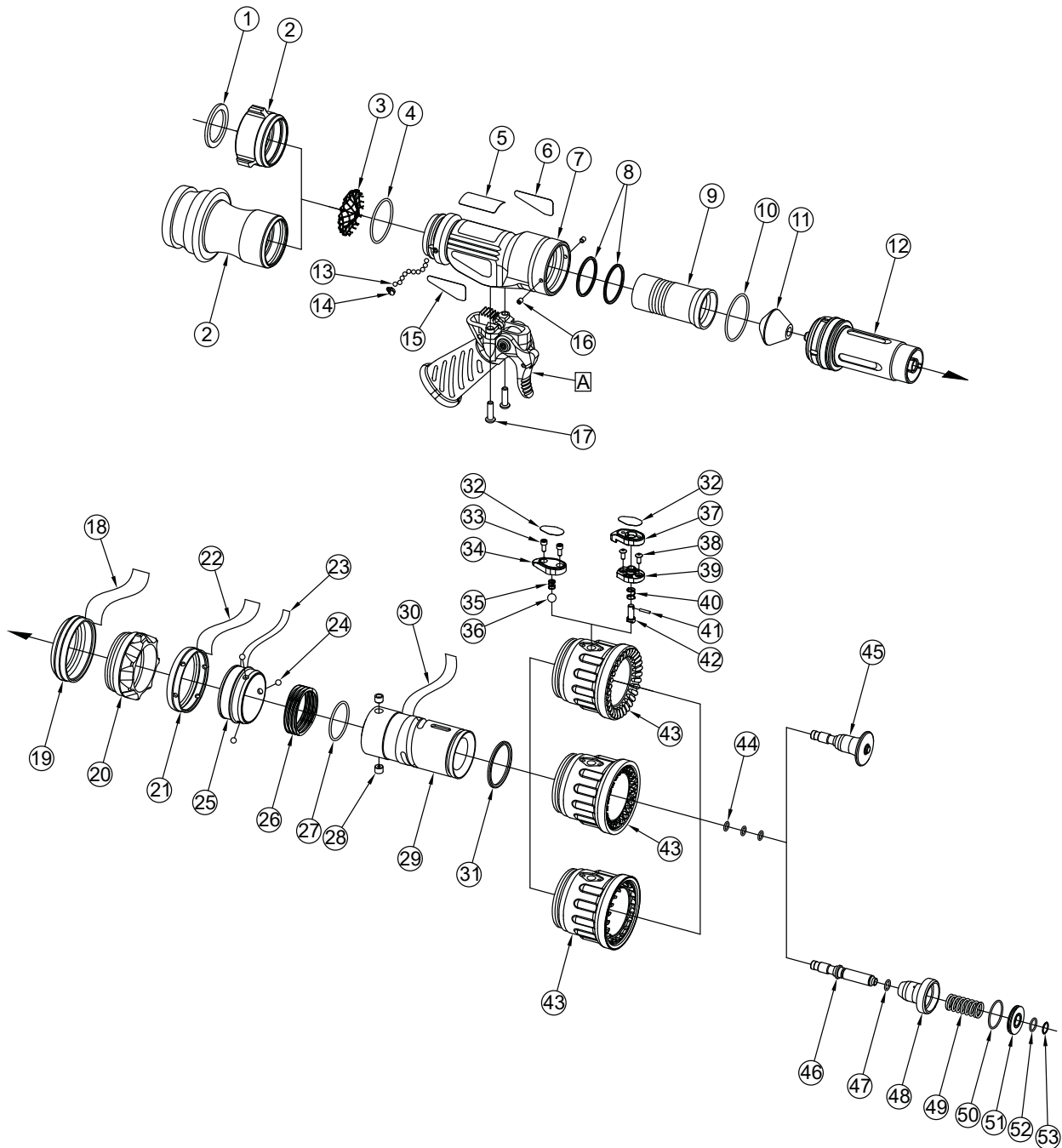

#	DESCRIPTION	QTY	1.0" G-FORCE PART #	1.5" G-FORCE PART #
1	GASKET 1.0"	1	V3040	N/A
	GASKET 1.5"		N/A	V3130
2	COUPLING 1.0"F	1	B680*	N/A
	COUPLING 1.5"F		N/A	G690*
	SWIVEL 2.5"BIC MALE		N/A	G694
3	GASKET GRABBER	1	B730	G606
4	VO-RING-***	1	VO-127	VO-134
5	LABEL: TOP	1	TN600LT	TN600LT
6	LABEL: LEFT	1	TN600LL	TN600LL
7	VALVE BODY	1	TN600G10	TN600G15
8	QUAD-RING-***	2	VOQ-4125	VOQ-4130
9	SLIDER	1	TN660B	TN660HM

#	DESCRIPTION	QTY	1.0" G-FORCE	1.5" G-FORCE
			PART #	PART #
10	O-RING-136	1	VO-136	VO-136
11	VALVE PLUG	1	TN611G10	TN611G15
12	BODY G-FORCE TIP	1	TN161	TN161
13	3/16" SS BALL	*	V2120 (28)	V2120 (34)
14	PORT PLUG	1	B770	B770
15	LABEL: RIGHT	1	TN600LR	TN600LR
16	10-32 X 1/4 SOCKET SET SCREW	2	VT10-32SS250	VT10-32SS250
17	1/4-20 X 7/8 BUTTON HEAD SCREW	2	VT25-20BH875	VT25-20BH875
18	INDEX RING LABEL - 30/60/95/125/150GPM @ 100PSI	1	G641S0L	G641S0L
	INDEX RING LABEL - 110/230/360/470/570 LPM 700 KPA		G641S0LM	G641S0LM
	INDEX RING LABEL - 30/60/95/125/150 GPM @ 75 PSI		G641S1L	G641S1L
	INDEX RING LABEL - 110/230/360/470/570 LPM 500 KPA		G641S1LM	G641S1LM
	INDEX RING LABEL - 100/200/300/400/500 LPM 500 KPA		G641S2LM	G641S2LM
	INDEX RING LABEL - 150 GPM @ 100 PSI		G641S5L	G641S5L
	INDEX RING LABEL - 150 GPM @ 75 PSI		G641S6L	G641S6L
	INDEX RING LABEL - AUTOMATIC		G641A0L	G641A0L
	INDEX RING LABEL - AUTOMATIC		G641A1L	G641A1L
	INDEX RING LABEL - PULSING 0/100/150 LPM, AUTO 250, 6 BAR		G641L5L	G641L5L
	INDEX RING LABEL - AUTO 7 BAR 100-360, 360-570 LPM		G641L5LM	G641L5LM
	INDEX RING LABEL - AUTO 75 PSI 30-100, 90-150 GPM		G641L6L	G641L6L
	INDEX RING LABEL - AUTO 5 BAR 100-390, 330-570 LPM		G641L6LM	G641L6LM
	INDEX RING LABEL - AUTO 100 PSI 30-70, 70-110, 110-150 GPM		G641L7L	G641L7L
	INDEX RING LABEL - AUTO 7 BAR 100-270, 270-430, 430-570 LPM		G641L7LM	G641L7LM
	INDEX RING LABEL - AUTO 75 PSI 30-80, 60-110,110-150 GPM		G641L8L	G641L8L
	INDEX RING LABEL - AUTO 5 BAR 100-300, 240-430, 420-570 LPM		G641L8LM	G641L8LM
	INDEX RING LABEL - AUTO 100 PSI 60-150 GPM, LOW (150 I.O.)		G641L9L	G641L9L
	INDEX RING LABEL - AUTO 7 BAR 250-570 LPM, LOW (570 I.O.)		G641L9LM	G641L9LM
	INDEX RING LABEL - AUTO 75 PSI 60-150 GPM, LOW (150 I.O.)		G641L10L	G641L10L
INDEX RING LABEL - AUTO 5 BAR 240-570 LPM, LOW (570 I.O.)	G641L10LM	G641L10LM		
19	SUBRING	1	G640	G640
20	INDEX RING - 30/60/95/125/150 GPM @ 100 PSI	1	G641S0	G641S0
	INDEX RING - 30/60/95/125/150 GPM @ 75 PSI		G641S1	G641S1
	INDEX RING - AUTOMATIC		G641A0	G641A0
	INDEX RING - AUTO 360/570 LPM @ 700 KPA		G641L5	G641L5
	INDEX RING - AUTO 390/570 LPM @ 500 KPA		G641L6	G641L6
	INDEX RING - AUTO 270/430/570 LPM @ 700 KPA		G641L7	G641L7
	INDEX RING - AUTO 300/430/570 LPM @ 500 KPA		G641L8	G641L8
	INDEX RING - AUTO 250/570 LPM LOW 700 KPA		G641L9	G641L9
	INDEX RING - AUTO 240/570 LPM LOW 500 KPA		G641L10	G641L10
21	CLAMP RING	1	G656	G656
22	CLAMP RING LABEL: G-FORCE - BLUE	1	G656L-B	G656L-B
	CLAMP RING LABEL: G-FORCE - GREY		G656L-G	G656L-G
	CLAMP RING LABEL: G-FORCE - BLACK		G656L-K	G656L-K
23	SHAPER GUIDE LABEL: G-FORCE - BLUE	1	G655L-B	G655L-B
	SHAPER GUIDE LABEL: G-FORCE - GRAY		G655L-G	G655L-G
	SHAPER GUIDE LABEL: G-FORCE - BLACK		G655L-K	G655L-K
24	.243" TORLON BALL	3	VB243TO	VB243TO
25	SHAPER GUIDE	1	G655	G655
26	FLUSH SPRING	1	G626	G626
27	O-RING-130	1	VO-130	VO-130
28	CAM	2	G624	G624
29	BARREL, SHAPER LOCK-OUT	1	G627	G627
30	BARREL LABEL: G-FORCE - BLUE	1	G625L-B	G625L-B
	BARREL LABEL: G-FORCE - GRAY		G625L-G	G625L-G
	BARREL LABEL: G-FORCE - BLACK		G625L-K	G625L-K

CONTINUED ON NEXT PAGE

#	DESCRIPTION	QTY	1.0" G-FORCE	1.5" G-FORCE
			PART #	PART #
31	QUAD-RING-225	1	VOQ-4225	VOQ-4225
32	TACTILE INDICATOR OR LEVER LABEL - BLUE	1	G657L-B	G657L-B
	TACTILE INDICATOR OR LEVER LABEL - GRAY		G657L-G	G657L-G
	TACTILE INDICATOR OR LEVER LABEL - BLACK		G657L-K	G657L-K
33	8-32 X 3/8 SOCKET HEAD SCREW	2	VT08-32SH375	VT08-32SH375
34	TACTILE INDICATOR	1	G657	G657
35	DETENT SPRING	1	H770	H770
36	3/8" TORLON BALL	1	VB375TO	VB375TO
37	SHAPER LATCH LEVER	1	G659	G659
38	8-32 X 3/8 BUTTON HEAD SCREW	2	VT08-32BH375	VT08-32BH375
39	SHAPER LATCH BASE	1	G658	G658
40	SPRING	1	G662	G662
41	DOWEL PIN	1	VP094X.50	VP094X.50
42	LOCK PIN	1	G660	G660
43	FIXED RUBBER TEETH SHAPER WITH BUMPER	1	G650	G650
	FIXED METAL TOOTH BUMPER SUBASSEMBLY		G954	G954
	SPINNING TOOTH BUMPER SUBASSEMBLY		G905	G905
44	QUAD-RING-011	3	VOQ-4011	VOQ-4011
45	FIXED BAFFLE	1	G630	G630
46	AUTOMATIC SHAFT	1	G633	G633
47	O-RING-012	1	VO-012	VO-012
48	AUTOMATIC BAFFLE	1	G632	G632
49	CONTROL SPRING 100 PSI	1	G635-100	G635-100
	CONTROL SPRING 75 PSI / 5 BAR		G635-75	G635-75
50	O-RING-025	1	VO-025	VO-025
51	75 PSI SUBBAFFLE	1	G634-75	G634-75
	100 PSI SUBBAFFLE		G634-100	G634-100
52	O-RING-014	1	VO-014	VO-014
53	SMALLEY RING	1	VR4225	VR4225
A	TRIGGER GRIP SUBASSEMBLY	1	TN900	TN900
	HIGH PRESSURE TRIGGER GRIP SUBASSEMBLY		TN900HP	TN900HP
* - CONSULT FACTORY FOR SPECIAL THREADS				

## 11.0 MAINTENANCE

TFT nozzles are designed and manufactured to be damage resistant and require minimal maintenance. However, as the primary firefighting tool upon which your life depends, it should be treated accordingly. To help prevent mechanical damage, do not drop or throw equipment.

### 11.1 FIELD LUBRICATION

All Task Force Tips' nozzles are factory lubricated with high quality silicone grease. This lubricant has excellent wash out resistance and long term performance in firefighting nozzles. If your department has unusually hard or sandy water, the moving parts of the nozzle may be affected. Foam agents and water additives contain soaps and chemicals that may break down the factory lubrication. The moving parts of the nozzle should be checked on a regular basis for smooth and free operation, and for signs of damage. **IF THE NOZZLE IS OPERATING CORRECTLY, THEN NO ADDITIONAL LUBRICANT IS NEEDED.** Any nozzle that is not operating correctly should be immediately removed from service.

The field use of Break Free CLP (spray or liquid) lubricant will help to restore the smooth and free operation of the nozzle. However, these lubricants do not have the washout resistance and long-term performance of the silicone grease. Therefore, re-application of Break Free CLP will be needed on a regular basis. **CAUTION:** Aerosol lubricants contain solvents that can swell O-Rings if applied in excess. The swelling can inhibit smooth operation of the moving parts. When used in moderation, as directed, the solvents quickly evaporate without adversely swelling the O-Rings.

The nozzle can be returned to the factory for a complete checkup and re-lubrication with silicone grease

#### PART ONE — COUPLING DOWN

Position the nozzle at a 45-degree angle with the COUPLING end down. Set the pattern to STRAIGHT STREAM. Then spray a short burst into these areas:

##### #1 FRONT PATTERN CONTROL SEAL

Spray in between the pattern control and the barrel.

##### #2 PRESSURE CONTROL UNIT

Spray in between the baffle and sub-baffle.

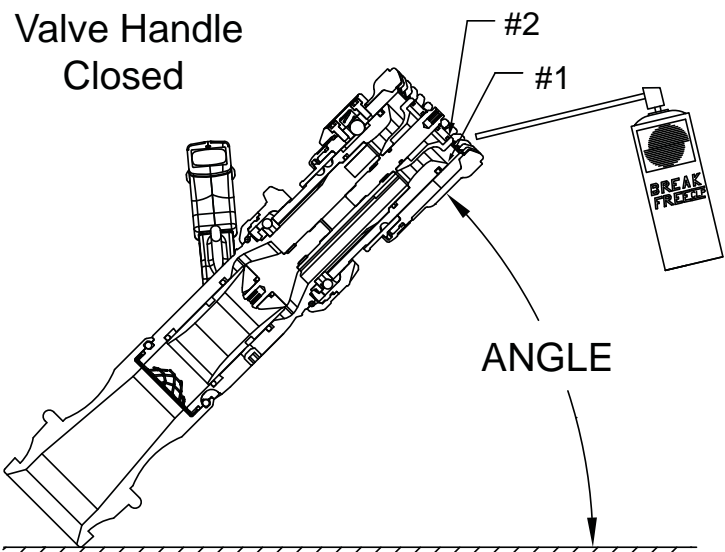

#### PART TWO — COUPLING UP

Position the nozzle at a 45-degree angle with the BUMPER end down. OPEN the valve handle and set the pattern to FLUSH. Spray a short burst in these areas:

##### #4 REAR SLIDER SEAL

Spray into the clearance between the slider and the valve body.

##### #4 DETENTS IN THE HANDLE

Spray a small amount on the detent followers located in the handle.

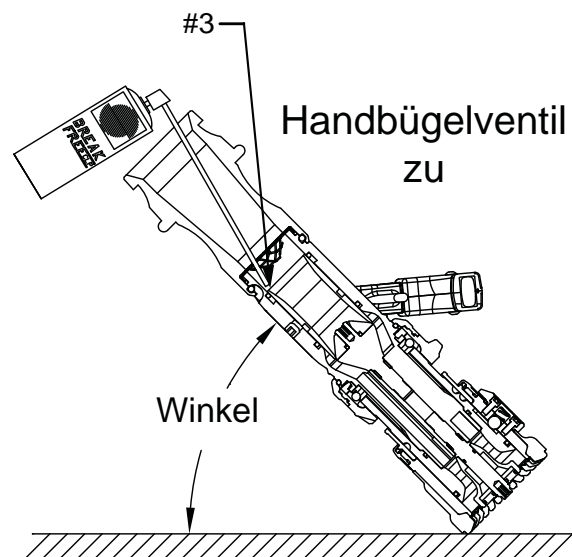

While holding nozzle at the angle, wait 30 seconds, then cycle the valve handle several times. Rotate the pattern control from straight stream to full fog. The pattern control should move freely and easily.

**IF THIS PROCEDURE DOES NOT RESTORE SMOOTH AND FREE OPERATION OF ALL THE MOVING PARTS, THEN FACTORY SERVICE IS NEEDED. • 24-HOUR HOT LINE — 800-348-2686 • www.tft.com**

## 11.2 IMPULSE TRIGGER VALVE LUBRICATION

- 1) Insert tube from BreakFree into drain hole in pistol grip.
- 2) With nozzle upside down spray a 2 second burst into the pistol grip. Holding a rag around the tube here can help keep excess BreakFree from the outside of the nozzle.
- 3) Keep nozzle upside down for at least 10 seconds to allow the BreakFree to flow into the valve area.
- 4) Check for smooth and free operation of the trigger. Repeat a second time if needed.

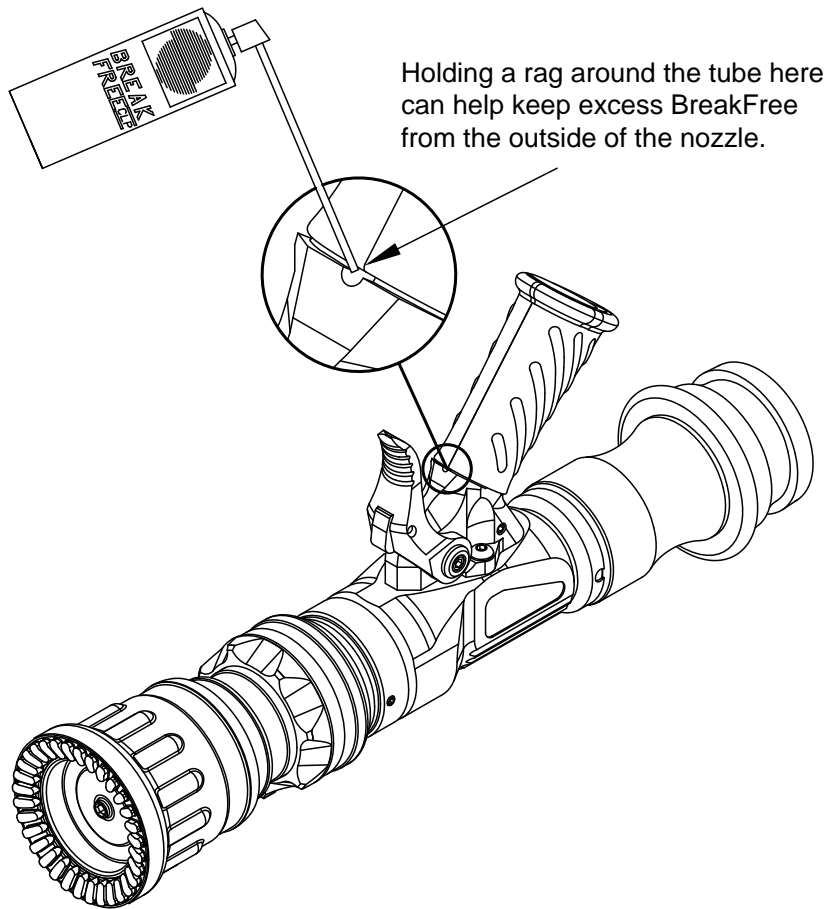

**If this procedure does not restore trigger operation then factory service is needed.  
24 hour Technical Service and Support - 800-348-2686 - [www.tft.com](http://www.tft.com)**

## 11.3 SERVICE TESTING

In accordance with NFPA 1962 (2013), nozzles must be tested a minimum of annually. Nozzles failing any part of this test must be removed from service, repaired and retested upon completion of the repair.

### 11.3.1 HYDROSTATIC TESTING

The maximum hydrostatic test pressure required for TFT's G-Force nozzles is 370 psi (25.5bar).

High Pressure 1 inch (25 mm) nozzles have a maximum hydrostatic test pressure of 1450 psi (100 bar).

Each nozzle with a shut off mechanism shall be tested in the following manner.

1. The nozzle shall be placed in a device capable of holding it and the shut off shall be closed.
2. A device capable of exerting a hydrostatic pressure of 300 psi (2070 kPa) or 1.5 times the maximum operating pressure, whichever is higher, shall be attached to the nozzle.
3. All air shall be bled from the system.
4. The gage pressure shall be increased by 50 psi (3.5 bar or 345 kPa) increments, held for 30 seconds at each pressure up to the maximum pressure for which the nozzle is being tested, and then held for one minute without leakage.
5. There shall be no sign of leakage through the valve or shut off.

### 11.3.2 FLOW TESTING

Flow testing must be conducted in the following manner.

1. The nozzle shall be mounted so that the flow rate and pressure through the nozzle and the pressure at the inlet can be accurately measured.
2. With the shut off fully open, the inlet pressure shall be adjusted to the rated pressure  $\pm 2$  percent.
3. The valve or shut off and pattern controls shall be operated through their full range of motion at 100 psi (6.9 bar or 690 kPa) with no signs of leaking, binding or other problems.
4. Evaluate the flow of nozzles as defined by NFPA 1964 in the following manner:
  - Basic Spray Nozzles** shall flow no less than and no more than 10 percent over the rated flow at the rated pressure in the straight stream and wide-angle fog settings.
  - Constant and Selectable Gallonage Nozzles** shall flow no less than and no more than 10 percent over the rated flow at the rated pressure at each predetermined flow selection.
  - Automatic (Constant Pressure) Spray Nozzles**
    1. The flow rate shall slowly be increased to the maximum rated flow, and the minimum and maximum pressures through the flow range recorded.
    2. Nozzles shall maintain their rated pressure  $\pm 15$  psi ( $\pm 1$  bar or  $\pm 100$  kPa) throughout the rated flow range.

*NFPA 1962: Standard for the care, use, inspection, service testing, and replacement of fire hose, couplings, nozzles and fire hose appliances. (2013 ed., Section 5.3). Quincy, MA: National Fire Protection Agency.*

### 11.3.3 RECORDS

A record of testing and repairs must be maintained from the time the nozzle is purchased until it is discarded. Each TFT nozzle is engraved with a unique serial number which, if so desired, can be used to identify nozzle for documentation purposes.

The following information, if applicable, must be included on the test record for each nozzle:

1. Assigned identification number
2. Manufacturer
3. Product or model designation
4. Vendor
5. Warranty
6. Hose connection size
7. Maximum operating pressure
8. Flow rate or range
9. Date received and date put in service
10. Date of each service test and service test results
11. Damage and repairs, including who made the repairs and the cost of repair parts
12. Reason removed from service

*NFPA 1962: Standard for the care, use, inspection, service testing, and replacement of fire hose, couplings, nozzles and fire hose appliances. (2013 ed., Section 5.5.4). Quincy, MA: National Fire Protection Agency.*

## 11.4 REPAIR

Factory service is available with repair time seldom exceeding one day in our facility. Factory-serviced nozzles are repaired by experienced technicians, wet tested to original specifications, and promptly returned. Repair charges for non-warranty items are minimal. Any returns should include a note as to the nature of the problem and whom to reach in case of questions.

Repair parts and service procedures are available for those wishing to perform their own repairs. Task Force Tips assumes no liability for damage to equipment or injury to personnel that is a result of user service. Contact the factory or visit the web site at [www.tft.com](http://www.tft.com) for parts lists, exploded views, test procedures and troubleshooting guides.

Performance tests shall be conducted on the G-Force nozzle after a repair, or anytime a problem is reported to verify operation in accordance with TFT test procedures. Consult factory for the procedure that corresponds to the model and serial number of the nozzle. Any equipment which fails the related test criteria should be removed from service immediately. Troubleshooting guides are available with each test procedure or equipment can be returned to the factory for service and testing.



**Any alterations to the nozzle and its markings could diminish safety and constitutes a misuse of this product.**

## 12.0 WARRANTY

Task Force Tips, Inc., 3701 Innovation Way, Valparaiso, Indiana 46383-9327 USA ("TFT") warrants to the original purchaser of its G-Force series nozzles ("equipment"), and to anyone to whom it is transferred, that the equipment shall be free from defects in material and workmanship during the five (5) year period from the date of purchase.

TFT's obligation under this warranty is specifically limited to replacing or repairing the equipment (or its parts) which are shown by TFT's examination to be in a defective condition attributable to TFT. To qualify for this limited warranty, the claimant must return the equipment to TFT, at 3701 Innovation Way, Valparaiso, Indiana 46383-9327 USA, within a reasonable time after discovery of the defect. TFT will examine the equipment. If TFT determines that there is a defect attributable to it, TFT will correct the problem within a reasonable time. If the equipment is covered by this limited warranty, TFT will assume the expenses of repair.

If any defect attributable to TFT under this limited warranty cannot be reasonably cured by repair or replacement, TFT may elect to refund the purchase price of the equipment, less reasonable depreciation, in complete discharge of its obligations under this limited warranty. If TFT makes this election, claimant shall return the equipment to TFT free and clear of any liens and encumbrances.

This is a limited warranty. The original purchaser of the equipment, any person to whom it is transferred, and any person who is an intended or unintended beneficiary of the equipment, shall not be entitled to recover from TFT any consequential or incidental damages for injury to person and/or property resulting from any defective equipment manufactured or assembled by TFT. It is agreed and understood that the price stated for the equipment is in part consideration for limiting TFT's liability. Some states do not allow the exclusion or limitation of incidental or consequential damages, so the above may not apply to you.

TFT shall have no obligation under this limited warranty if the equipment is, or has been, misused or neglected (including failure to provide reasonable maintenance) or if there have been accidents to the equipment or if it has been repaired or altered by someone else.

**THIS IS A LIMITED EXPRESS WARRANTY ONLY. TFT EXPRESSLY DISCLAIMS WITH RESPECT TO THE EQUIPMENT ALL IMPLIED WARRANTIES OF MERCHANTABILITY AND ALL IMPLIED WARRANTIES OF FITNESS FOR A PARTICULAR PURPOSE. THERE IS NO WARRANTY OF ANY NATURE MADE BY TFT BEYOND THAT STATED IN THIS DOCUMENT.**

This limited warranty gives you specific legal rights, and you may also have other rights which vary from state to state.

### 13.0 OPERATION AND INSPECTION CHECKLIST

TFT's G-Force is designed and manufactured to be damage resistant and require minimal maintenance. However, as the primary fire fighting tool upon which your life depends, it should be treated accordingly.

**BEFORE EACH USE** the nozzle must be inspected to this checklist:

- 1) There is no obvious damage such as missing, broken or loose parts, damaged labels etc.
- 2) Debris screen is free of debris
- 3) Coupling is tight and leak free
- 4) Valve operates freely through full range and regulates flow
- 5) "OFF" position does fully shut off and flow is stopped
- 6) Nozzle flow is adequate as indicated by pump pressure and nozzle reaction
- 7) Shaper turns freely and adjusts pattern through full range
- 8) Shaper turns into full flush and out of flush with normal flow and pressure restored
- 9) Shaper detent (if so equipped) operates smoothly and positively.

**BEFORE BEING PLACED BACK IN SERVICE**, nozzles must be inspected to this checklist;

- 1) All controls and adjustments are operational
- 2) Shut off valve (if so equipped) closes off the flow completely
- 3) There are no broken or missing parts
- 4) There is no damage to the nozzle that could impair safe operation (e.g. dents, cracks, corrosion or other defects)
- 5) The thread gasket is in good condition
- 6) The waterway is clear of obstructions
- 7) Nozzle is clean and markings are legible
- 8) Coupling is retightened properly
- 9) Shaper is set to desired pattern
- 10) Shutoff handle is stored in the OFF position

*NFPA 1962: Standard for the care, use, inspection, service testing, and replacement of fire hose, couplings, nozzles and fire hose appliances. (2013 ed., Section 5.2.2). Quincy, MA: National Fire Protection Agency.*



**Any nozzle failing any part of the checklist is unsafe for use and must have the problem corrected before use or being placed back into service. Operating a nozzle that has failed the checklist is a misuse of this equipment.**