

MANUAL: ICE-CONTROL Anti-icing & Deicing Nozzles

INSTRUCTIONS FOR SAFE OPERATION AND MAINTENANCE

⚠ WARNING Read instruction manual before use. Operation of this nozzle without understanding the manual and receiving proper training can be dangerous and is a misuse of this equipment. Call 1-800-348-2686 or 1-219-462-6161 with any questions.

This instruction manual is intended to familiarize ground support crew and maintenance personnel with the operation, servicing and safety procedures associated with TFT ice-control nozzles.

This manual should be kept available to all operating and maintenance personnel.

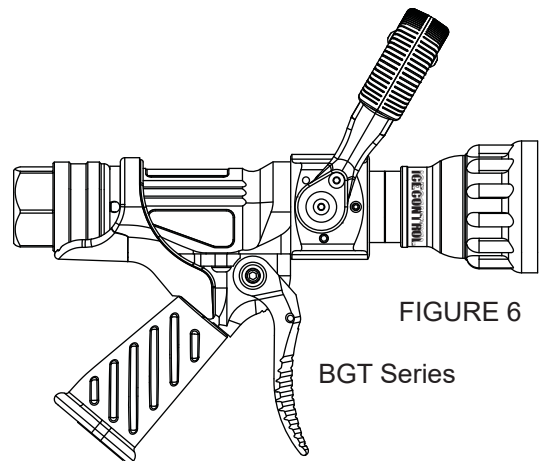
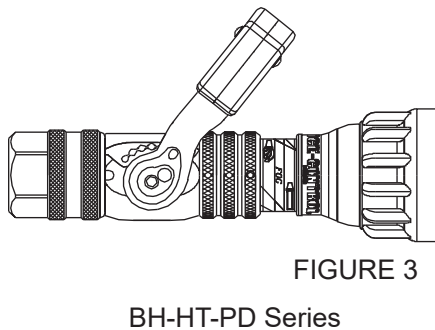
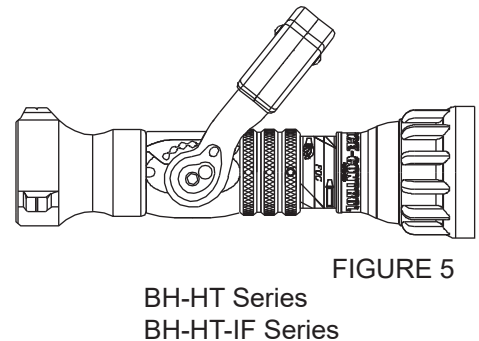
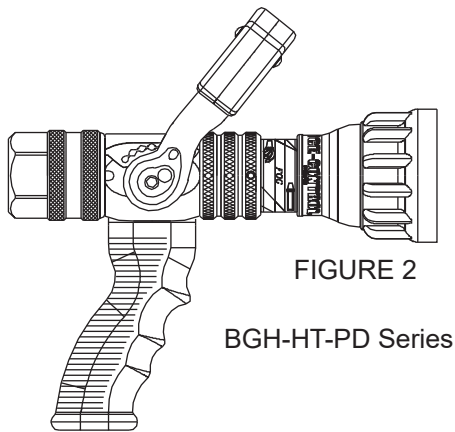
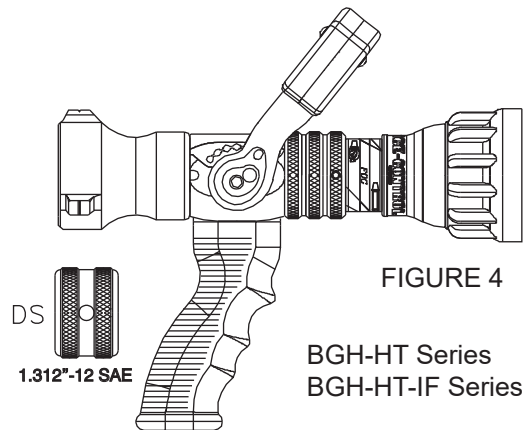
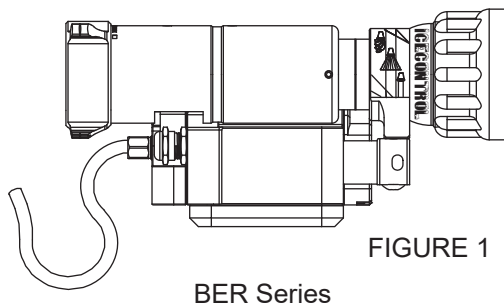

Note: These nozzles, while regularly used for fire fighting, have been modified to meet the needs of the individual aviation customers by their specifications and requirements. As modified fire fighting nozzles, Task Force Tips relies on these specifications presented by the users, and does not independently test, confirm, or warrant, the suitability of any particular nozzle for an application. It is the responsibility of the end user to specify the flows, pressures, and configurations to meet their requirement and application.

1.0 MEANING OF SAFETY SIGNAL WORDS	3
2.0 GENERAL INFORMATION	3
2.1 VARIOUS MODELS AND TERMS.....	4
3.0 FLOW CHARACTERISTICS.....	8
3.1 TRAJECTORY CHARTS	9
3.1.1 ANTI-ICING NOZZLES	9
3.1.2 DEICING NOZZLES.....	10
3.1.3 ELECTRIC REMOTE NOZZLES	11
4.0 NOZZLE CONTROLS	12
4.1 FLOW CONTROL.....	12
4.1.1 LEVER TYPE FLOW CONTROL	12
4.1.2 IMPULSE TRIGGER FLOW CONTROL	12
4.1.2.1 IMPULSE TRIGGER LOCK	12
4.1.2.2 IMPULSE TRIGGER FLOW CONTROL	
SPEED ADJUSTMENT	13
4.1.2.3 NORMAL OPERATING POSITION.....	13
4.1.2.4 SETTING FIXED HANDLE POSITION	14
4.1.3 ELECTRIC REMOTE NOZZLE	14
4.2 PATTERN AND FLUSH CONTROL.....	15
4.2.1 PATTERN CONTROL.....	15
4.2.1.1 MANUAL PATTERN CONTROL.....	15
4.2.1.2 ELECTRIC PATTERN CONTROL.....	15
4.2.2 FLUSH CONTROL.....	15
4.2.2.1 VALVED NOZZLE FLUSHING	16
4.2.2.2 ELECTRIC REMOTE FLUSHING	16
5.0 USE OF ICE-CONTROL NOZZLES	17
6.0 FIELD INSPECTION	18
6.1 FIELD LUBRICATION PROCEDURE	19
7.0 PARTS LIST	20
7.1 ICE-CONTROL NOZZLE VALVED MODELS.....	20-21
7.2 ICE-CONTROL TRIGGER NOZZLE MODELS.....	22-23
7.3 ICE-CONTROL NOZZLE ELECTRIC REMOTE MODEL..	24-25
7.3 12-24V ACTUATOR ASSEMBLY	26
8.0 ANSWERS TO YOUR QUESTIONS.....	27
9.0 WARRANTY	27
10.0 INSPECTION CHECKLIST	BACK COVER

1.0 MEANING OF SAFETY SIGNAL WORDS

A safety related message is identified by a safety alert symbol and a signal word to indicate the level of risk involved with a particular hazard. Per ANSI standard Z535.6-2011, the definitions of the four signal words are as follows:



DANGER indicates a hazardous situation which, if not avoided, will result in death or serious injury.



WARNING indicates a hazardous situation which, if not avoided, could result in death or serious injury.



CAUTION indicates a potentially hazardous situation which, if not avoided, could result in minor or moderate injury.



NOTICE is used to address practices not related to physical injury.

2.0 GENERAL INFORMATION

Task Force Tips ice-control nozzles have been specifically designed to apply water, glycol or water/glycol based ice-control fluids to aircraft exterior surfaces at fluid temperatures up to 210° F (99° C). The proper use of deicing agents aids ground support professionals in the removal of ice from aircraft fuselage, landing gear and wing surfaces. The proper use of anti-icing agents aids ground support professionals in their efforts to prevent ice and snow from adhering to the wings of aircraft. This may extend holdover times. These nozzles are only part of a complete ice-control system. Suitability of a particular nozzle for applying deicing or anti-icing fluids must be determined by the end user of the nozzle.

Handled ice-control nozzles have:

- Automatic Pressure Control for optimum reach.
- Slide-Type valve with heat resistant EPDM seat - The valve design controls the flow through the nozzle while minimizing turbulence that causes shear and degradation of Anti-icing fluids.
- Pattern Control - This nozzle features a “toothless” bumper to reduce turbulence and can be easily adjusted for any desired spray pattern between a straight stream or wide spray position.
- One-Twist Flushing - Easily flushable while flowing to clear trapped debris.
- Pistol Grip - (**BGH models only**). The pistol grip and flow control handle are insulated to protect the operator from the high temperatures generated by heated fluids passing through the nozzle.
- Trigger nozzle - (**BGT models only**). The trigger type control valve pistol grip, valve body and stationary top handle are insulated to protect the operator from the high temperatures generated by heated fluids passing through the nozzle.

The Society of Automotive Engineers (SAE) Committee G-12E, Subcommittee Aircraft Ground Equipment, has accepted the following color-coding for deicing and anti-icing fluids.

Deicing Fluids - Red with Yellow Stripe

Anti-icing Fluids - Green with Yellow Stripe

Deicing Nozzle models with pistol grips are shipped with a Red with Yellow Stripe pistol grip installed.

Trigger Deicing Nozzle is shipped with TFT Part# HM625-RED (1) & HM625-YEL (1) handle covers - installed.

Anti-icing Nozzle models with pistol grips are shipped with a Green with Yellow Stripe pistol grip installed.

Trigger Anti-icing Nozzle is shipped with TFT Part# HM625-GRN (1) & HM625-YEL (1) handle covers - installed.

Combination De/Anti-icing Nozzle models with pistol grip are shipped with a black pistol grip installed and two pistol grips with the above color coding are included with each nozzle. Trigger Combination De/Anti-icing Nozzle models are shipped with black handle covers installed and handle covers with the above color coding are included with each nozzle. It is the responsibility of the end user agency to install the correct color coded pistol grip for the application where the nozzle is utilized.

Electric remote control ice-control nozzles have:

- Automatic Pressure Control for optimum reach.
- Pattern Control- Electrically operated pattern adjustment, features a “toothless” bumper to reduce turbulence, and can be easily adjusted for any desired spray pattern between a straight stream or wide spray position.
- Sealed electric motor with easy to use manual override.
- Flush - Easily flushable while flowing to clear trapped debris.
- Swivel connecting coupling for ease of installation.

2.1 VARIOUS MODELS AND TERMS

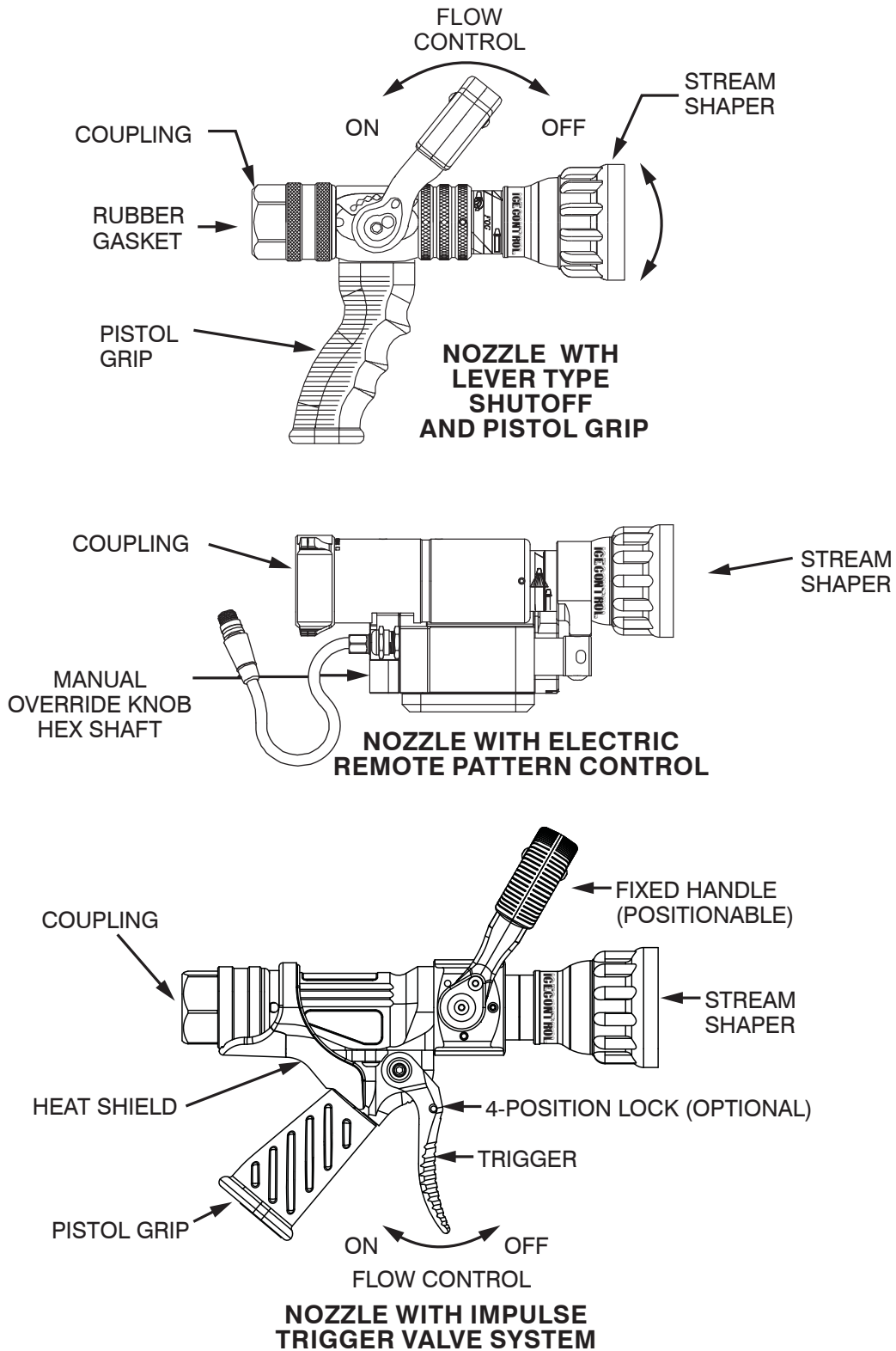

FIGURE 2.1
COMMON MODELS AND TERMS

CAUTION

Mismatched or damaged threads may cause nozzle to leak heated fluid or uncouple from hose/piping under pressure and could cause injury. Nozzle must be mated to hose/piping with matched threads.

ANTI-ICING NOZZLES - FOR USE WITH ANTI-ICING FLUIDS

MODEL	FLOW RANGE (4)***	NOMINAL (5) PRESSURE	STANDARD COUPLING	VALVED	PATTERN CONTROL	FIGURE
BER-HT75	10-60 gpm*** 38-227 lpm***	75 psi 5 bar	1.5"-9 NH	NO	ELECTRIC (12-24VDC)	1
BGH-HT75-PD	10-60 gpm*** 38-227 lpm***	75 psi 5 bar	1.0"-11.5 NPT	YES VALVED	MANUAL TWIST	2
BGT-HT75-PD	10-60 gpm*** 38-227 lpm***	75 psi 5 bar	1.0"-11.5 NPT	YES TRIGGER	MANUAL TWIST	6
BH-HT75	10-60 gpm*** 38-227 lpm***	75 psi 5 bar	1.5"-9 NH	YES VALVED	MANUAL TWIST	5
BGH-HT50	10-60 gpm*** 38-227 lpm***	50 psi 3 bar	1.5"-9 NH	YES VALVED	MANUAL TWIST	4
BGT-HT50	10-60 gpm*** 38-227 lpm***	50 psi 3 bar	1.5"-9 NH	YES TRIGGER	MANUAL TWIST	6
BH-HT50	10-60 gpm*** 38-227 lpm***	50psi 3 bar	1.5"-9 NH	YES VALVED	MANUAL TWIST	5
BH-HT50-IF	10-60 gpm*** 38-227 lpm***	50psi 3 bar	1.5"-11.5 NPSH	YES VALVED	MANUAL TWIST	5
BGH-HT50-DS	10-60 gpm*** 38-227 lpm***	50 psi 3 bar	1.312"-12 SAE	YES VALVED	MANUAL TWIST	4
BGT-HT50-DS	10-60 gpm*** 38-227 lpm***	50 psi 3 bar	1.312"-12 SAE	YES TRIGGER	MANUAL TWIST	6
BGH-HT50-PD	10-60 gpm*** 38-227 lpm***	50 psi 3 bar	1.0"-11.5 NPT	YES VALVED	MANUAL TWIST	2
BGT-HT50-PD	10-60 gpm*** 38-227 lpm***	50 psi 3 bar	1.0"-11.5 NPT	YES TRIGGER	MANUAL TWIST	6

*** CAN BE USED FOR ANTI-ICING FLUIDS WHEN OPERATED BETWEEN 20-30 gpm
(4) CONVERSION - 1 gpm = 3.785 lpm - (5) CONVERSION - 1 psi = 0.067 bar

Table 2.1.1

DE-ICING NOZZLES - FOR USE WITH DE-ICING FLUIDS

MODEL	FLOW RANGE (4)	NOMINAL (5) PRESSURE	STANDARD COUPLING	VALVED	PATTERN CONTROL	FIGURE
BER-HT150	10-60 gpm 38-227 lpm	150 psi 10 bar	1.5"-9 NH	NO	ELECTRIC (12-24VDC)	1
BERP-HT150*	10-60 gpm 38-227 lpm	150 psi 10 bar	1.5"-9 NH	NO	ELECTRIC (12-24VDC) 6 PIN CABLE CONNECTION	1
BER-HT1503	20-25 gpm 76-95 lpm	150 psi 10 bar	1.5"-9 NH	NO	ELECTRIC (12-24VDC)	1
BGH-HT100-PD	10-60 gpm 38-227 lpm	100 psi 7 bar	1.0"-11.5 NPT	YES VALVED	MANUAL TWIST	2
BGT-HT100-PD	10-60 gpm 38-227 lpm	100 psi 7 bar	1.0"-11.5 NPT	YES TRIGGER	MANUAL TWIST	6
BH-HT100-PD	10-60 gpm 38-227 lpm	100 psi 7 bar	1.0"-11.5 NPT	YES VALVED	MANUAL TWIST	3
BH-HT100-IF	10-60 gpm 38-227 lpm	100 psi 7 bar	1.5"-11.5 NPSH	YES VALVED	MANUAL TWIST	5
BGH-HT150-PD	10-60 gpm 38-227 lpm	150 psi 10 bar	1.0"-11.5 NPT	YES VALVED	MANUAL TWIST	2
BGT-HT150-PD	10-60 gpm 38-227 lpm	150 psi 10 bar	1.0"-11.5 NPT	YES TRIGGER	MANUAL TWIST	6
BH-HT150-PD	10-60 gpm 38-227 lpm	150 psi 10 bar	1.0"-11.5 NPT	YES VALVED	MANUAL TWIST	3
BGH-HT1503PD	20-25 gpm 76-95 lpm	150 psi 10 bar	1.0"-11.5 NPT	YES VALVED	MANUAL TWIST	2
BGT-HT1503PD	20-25 gpm 76-95 lpm	150 psi 10 bar	1.0"-11.5 NPT	YES TRIGGER	MANUAL TWIST	6

***NOTE: BERP-HT150 includes electrical plug connection for Task Force Tips, Tornado monitors only.**

Table 2.1.2

COMBINATION NOZZLES - WITH LOW FLOW FIXED GALLONAGE SETTING FOR ANTI-ICING WITH ANTI-ICING FLUIDS AND HIGH FLOW AUTOMATIC PRESSURE CONTROL SETTING FOR DEICING WITH DEICING FLUIDS

COMBINATION NOZZLES

MODEL	ANTI-ICING SETTING (4,5)***	DEICING SETTING (4,5)	STANDARD COUPLING	VALVED	PATTERN CONTROL	FIGURE
BER-HT120	20 gpm @ 50psi 76 lpm @ 3 bar	80 gpm @120 psi 303 lpm @ 8 bar	1.5"-9 NH	NO	ELECTRIC (12-24VDC)	1
BER-HT1501	20 gpm @ 50psi 76 lpm @ 3 bar	80 gpm @150 psi 303 lpm @ 10 bar	1.5"-9 NH	NO	ELECTRIC (12-24VDC)	1
BER-HT1502	20 gpm @ 50psi 76 lpm @ 3 bar	40 gpm @ 150 psi 151 lpm @ 10 bar	1.5"-9 NH	NO	ELECTRIC (12-24VDC)	1
BERP-HT120*	20 gpm @ 50psi 76 lpm @ 3 bar	80 gpm @ 120psi 303 lpm @ 8 bar	1.5"-9 NH	NO	ELECTRIC (12-24VDC) 6 PIN CABLE CONNECTION	1
BGH-HT120-PD	20 gpm @ 50psi 76 lpm @ 3 bar	80 gpm @120 psi 303 lpm @ 8 bar	1.0"-11.5 NPT	YES VALVED	MANUAL TWIST	2
BGT-HT120-PD	20 gpm @ 50psi 76 lpm @ 3 bar	80 gpm @120 psi 303 lpm @ 8 bar	1.0"-11.5 NPT	YES TRIGGER	MANUAL TWIST	6
BGH-HT120-IF	20 gpm @ 50psi 76 lpm @ 3 bar	80 gpm @120 psi 303 lpm @ 8 bar	1.5"-11.5 NPSH	YES VALVED	MANUAL TWIST	4
BGT-HT120-IF	20 gpm @ 50psi 76 lpm @ 3 bar	80 gpm @120 psi 303 lpm @ 8 bar	1.5"-11.5 NPSH	YES TRIGGER	MANUAL TWIST	6
BGH-HT1502PD	20 gpm @ 50psi 76 lpm @ 3 bar	40 gpm @ 150 psi 151 lpm @ 10 bar	1.0"-11.5 NPT	YES VALVED	MANUAL TWIST	2
BGT-HT1502PD	20 gpm @ 50psi 76 lpm @ 3 bar	40 gpm @ 150 psi 151 lpm @ 10 bar	1.0"-11.5 NPT	YES TRIGGER	MANUAL TWIST	6
BH-HT-120	20 gpm @ 50psi 76 lpm @ 3 bar	80 gpm @120 psi 303 lpm @ 8 bar	1.5"-9 NH	YES VALVED	MANUAL TWIST	5
BH-HT120-IF	20 gpm @ 50psi 76 lpm @ 3 bar	80 gpm @120 psi 303 lpm @ 8 bar	1.5"-11.5 NPSH	YES VALVED	MANUAL TWIST	5
BH-HT120-PD	20 gpm @ 50psi 76 lpm @ 3 bar	80 gpm @120 psi 303 lpm @ 8 bar	1.0"-11.5 NPT	YES VALVED	MANUAL TWIST	3
BH-HT1502	20 gpm @ 50psi 76 lpm @ 3 bar	40 gpm @150 psi 151 lpm @ 10 bar	1.0"-11.5 NPT	YES VALVED	MANUAL TWIST	5

***NOTE: BERP-HT120 includes electrical plug connection for Task Force Tips, Tornado monitors only.**

*** CAN BE USED FOR ANTI-ICING FLUIDS WHEN OPERATED BETWEEN 20-30 GPM

(4) CONVERSION - 1 GPM = 3.785 LITERS, (5) CONVERSION - 1 PSI = 0.067 BAR

Table 2.1.3

3.0 FLOW CHARACTERISTICS

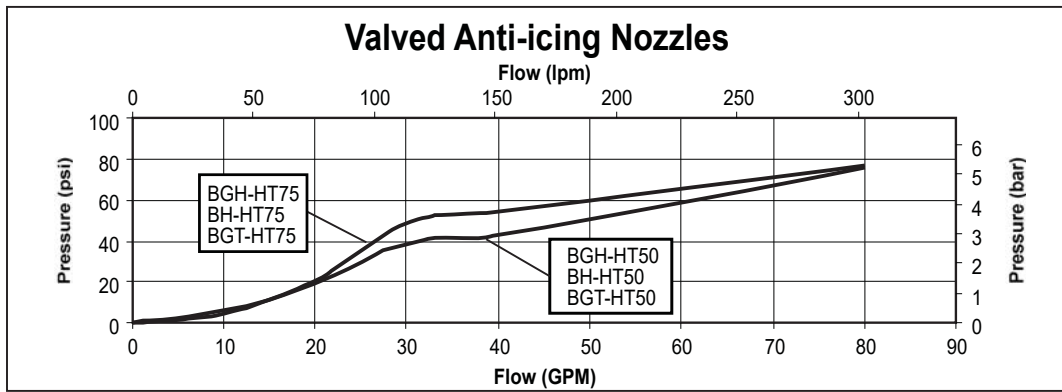
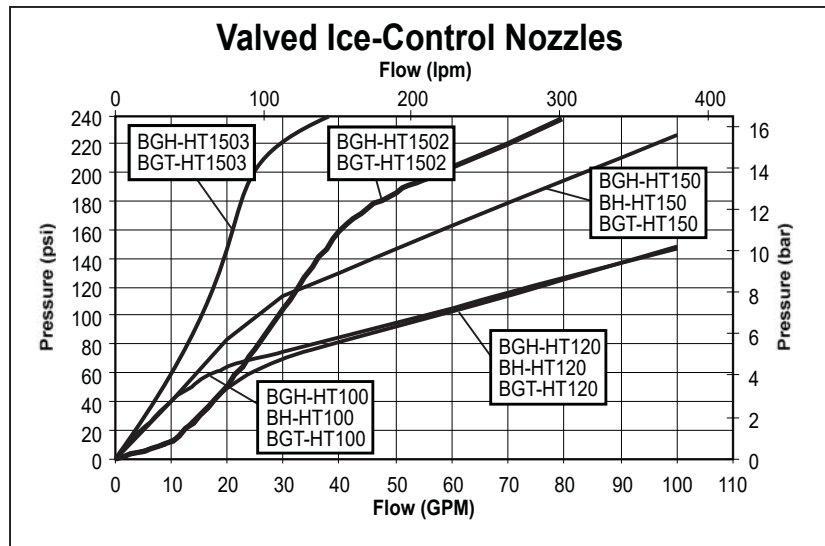

BGT trigger nozzles have same flow characteristics as BGH models.

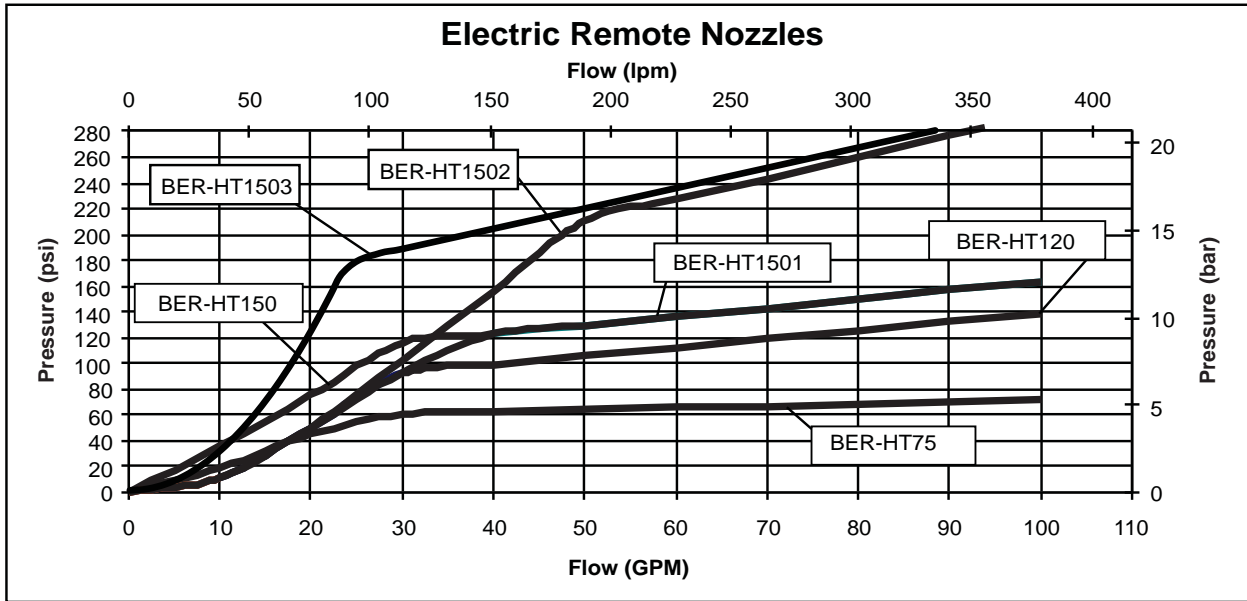

FIGURE 3.0 - FLOW CURVES

Friction pressure losses may vary due to differences in hoses/piping construction resulting in flows different than those shown. Flows can be calculated using conventional hydraulics.

These flow curves are for reference only. User must determine suitability of the stream for the particular purpose for which it is being used. Such factors as fluid/water ratio, manufacturer of fluid, fluid temperature and equipment used to supply fluid to the nozzle may produce variation from the flows and pressures shown above.

3.1 TRAJECTORY CHARTS FOR ICE-CONTROL NOZZLES

3.1.1 ANTI-ICING NOZZLES

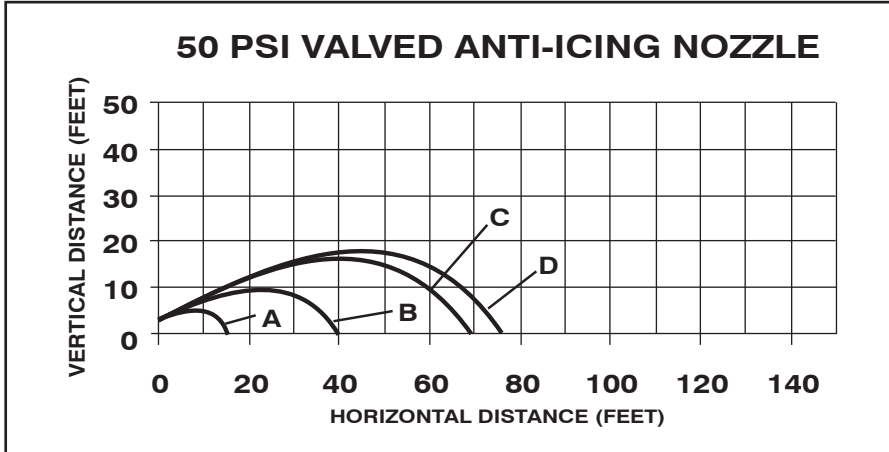

CURVE	GPM FLOW	PSI INLET PRESSURE	LBS REACTION
A	10	19	1
B	20	45	4
C	30	60	9
D	40	64	13

CURVE	LPM FLOW	KG/CM ² INLET PRESSURE	KG F REACTION
A	38	1.3	.5
B	76	3.1	2.1
C	110	4.1	4.5
D	150	4.4	6.3

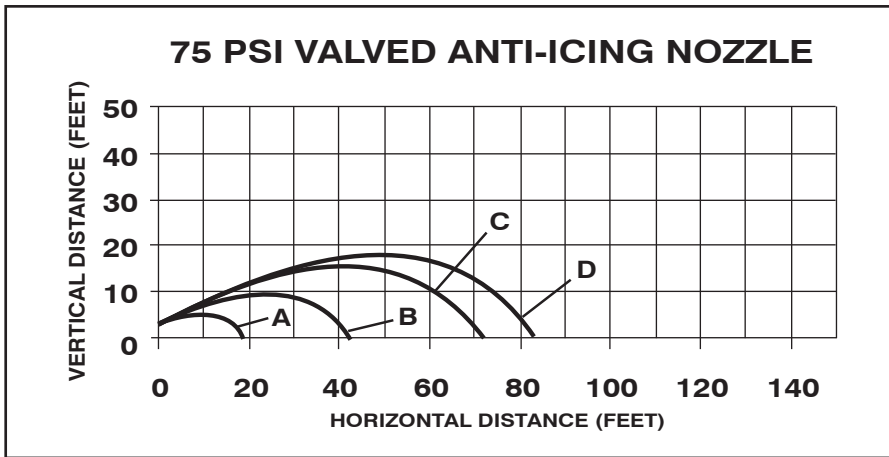

CURVE	GPM FLOW	PSI INLET PRESSURE	LBS REACTION
A	10	5	1
B	20	21	5
C	30	49	11
D	40	55	15

CURVE	LPM FLOW	KG/CM ² INLET PRESSURE	KG F REACTION
A	38	.3	.5
B	76	1.4	2.2
C	110	3.4	5.0
D	150	3.8	7.1

These trajectories, reach and reaction numbers are provided for reference. All data based on 30 degree nozzle discharge angle, in straight stream setting. Actual trajectories, reach and reactions may vary with wind conditions, fluid type, fluid/water ratio, fluid temperature, pressure and flow at the nozzle. It is the operator's responsibility to determine that the system provides adequate reach for the intended purpose.

CAUTION

Deicing nozzles operate at high pressures. Direct impingement of the stream at right angles to some aircraft surfaces may cause deformation or damage. User should direct stream at shallow angles to sensitive surfaces.

3.1.2 DEICING NOZZLES

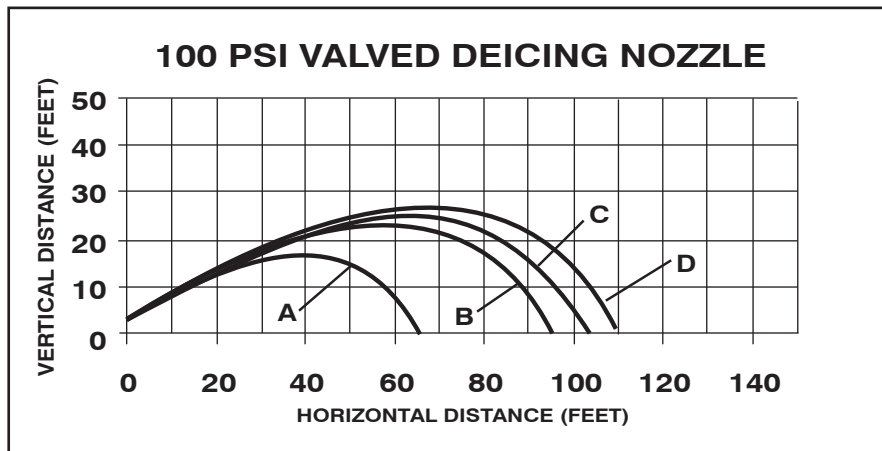

CURVE	GPM FLOW	PSI INLET PRESSURE	LBS REACTION
A	20	64	8
B	40	85	19
C	50	95	25
D	60	100	31

CURVE	LPM FLOW	KG/CM ² INLET PRESSURE	KG/REACTION
A	76	4.4	3.8
B	150	5.9	8.8
C	190	6.6	12
D	230	6.9	15

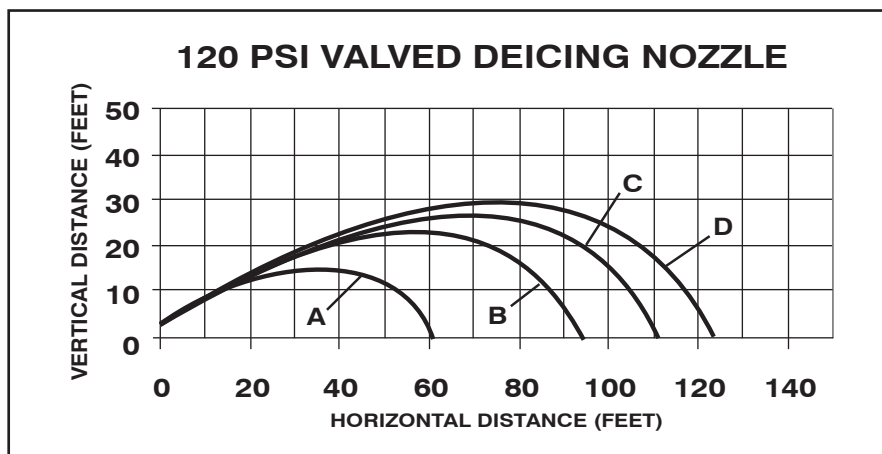

CURVE	GPM FLOW	PSI INLET PRESSURE	LBS REACTION
A	20	50	7
B	40	81	18
C	60	105	31
D	80	120	44

CURVE	LPM FLOW	KG/CM ² INLET PRESSURE	KG/REACTION
A	76	3.4	3.4
B	150	5.6	8.6
C	230	7.2	15
D	300	8.3	21

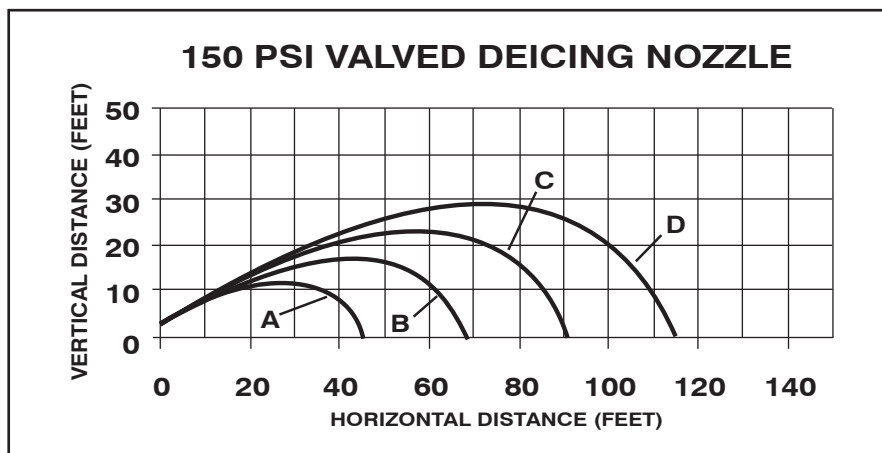

CURVE	GPM FLOW	PSI INLET PRESSURE	LBS REACTION
A	10	40	3
B	20	83	9
C	30	114	16
D	50	150	31

CURVE	LPM FLOW	KG/CM ² INLET PRESSURE	KG/REACTION
A	38	2.8	1.5
B	76	5.7	4.3
C	110	7.9	7.6
D	190	10	15

These trajectories, reach and reaction numbers are provided for reference. All data based on 30 degree nozzle discharge angle, in straight stream setting. Actual trajectories, reach and reactions may vary with wind conditions, fluid type, fluid/water ratio, fluid temperature, pressure and flow at the nozzle. It is the operator's responsibility to determine that the system provides adequate reach for the intended purpose.

CAUTION

Deicing nozzles operate at high pressures. Direct impingement of the stream at right angles to some aircraft surfaces may cause deformation or damage. User should direct stream at shallow angles to sensitive surfaces.

3.1.3 ELECTRIC REMOTE NOZZLES

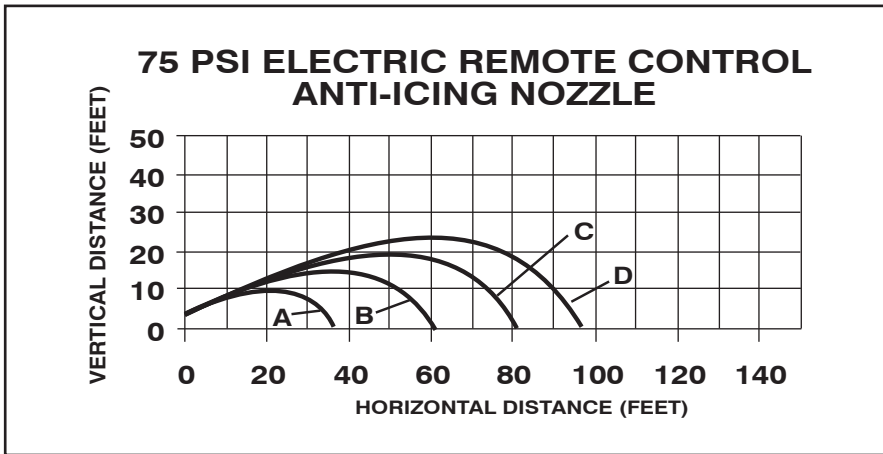

CURVE	GPM FLOW	PSI INLET PRESSURE	LBS REACTION
A	10	19	2
B	20	45	7
C	30	60	12
D	50	64	20

CURVE	LPM FLOW	KG/CM ² INLET PRESSURE	KG F REACTION
A	38	1.3	1.0
B	76	3.1	3.2
C	110	4.1	5.5
D	190	4.4	9.5

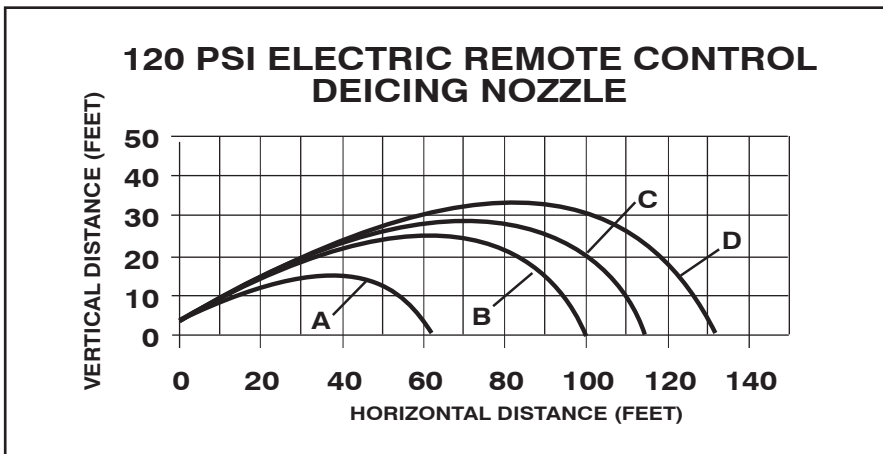

CURVE	GPM FLOW	PSI INLET PRESSURE	LBS REACTION
A	20	50	7
B	40	93	19
C	60	106	31
D	80	120	44

CURVE	LPM FLOW	KG/CM ² INLET PRESSURE	KG F REACTION
A	76	3.4	3.4
B	150	6.4	9.2
C	230	7.3	15
D	300	8.3	21

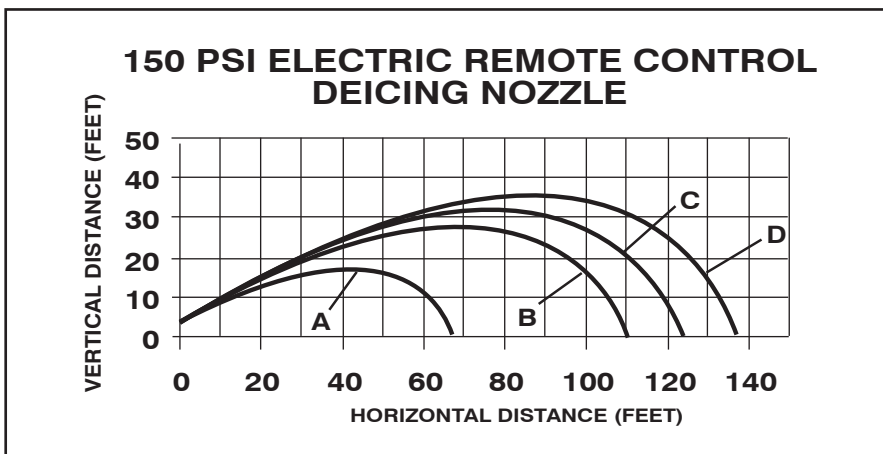

CURVE	GPM FLOW	PSI INLET PRESSURE	LBS REACTION
A	20	74	9
B	40	123	22
C	60	136	35
D	80	150	49

CURVE	LPM FLOW	KG/CM ² INLET PRESSURE	KG F REACTION
A	76	5.1	4.1
B	150	8.5	11
C	230	9.4	17
D	300	10	23

These trajectories, reach and reaction numbers are provided for reference. All data based on 30 degree nozzle discharge angle, in straight stream setting. Actual trajectories, reach and reactions may vary with wind conditions, fluid type, fluid/water ratio, fluid temperature, pressure and flow at the nozzle. It is the operator's responsibility to determine that the system provides adequate reach for the intended purpose.

CAUTION Deicing nozzles operate at high pressures. Direct impingement of the stream at right angles to some aircraft surfaces may cause deformation or damage. User should direct stream at shallow angles to sensitive surfaces.

4.0 NOZZLE CONTROLS

Nozzle control valves must be opened slowly to eliminate unnecessary strain on the hose and couplings and reduce pressure surges. Nozzles attached to an in-service hose shall be stored in the off position.

4.1 FLOW CONTROL

4.1.1 LEVER TYPE FLOW CONTROL

On models with a lever type shutoff handle the nozzle is shut off when the handle is fully forward. The valve handle has six detent flow positions. These detent positions allow the nozzle operator to regulate the fluid flow of the nozzle depending on the need or what can be safely and effectively handled.

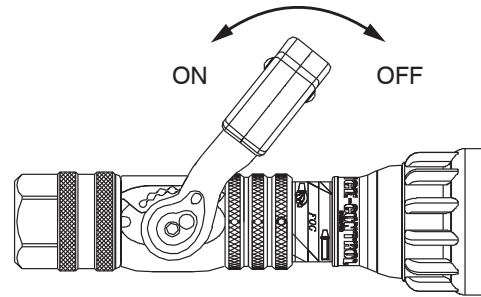

4.1.2 IMPULSE TRIGGER FLOW CONTROL

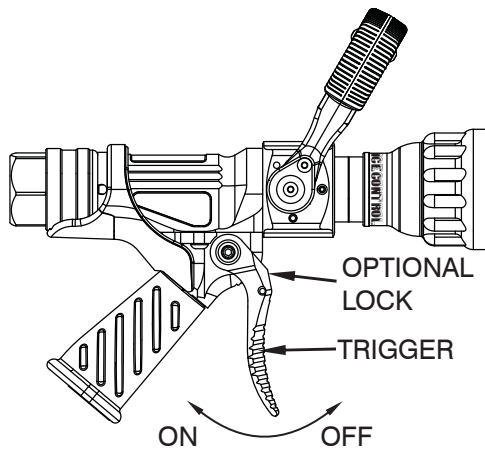

NOTE: THE TRIGGER RETURNS TO OFF IF NOT HELD OR LOCKED

WARNING

Do not intentionally release the nozzle while flowing and trust the valve to shut off automatically. The trigger nozzle's ability to shut off by itself represents an extra level of safety when following normal nozzle handling procedures. To rely on it as the sole means of safety increases the risk of injury from an out of control nozzle. Release nozzle when flow has stopped.

4.1.2.1 IMPULSE TRIGGER LOCK

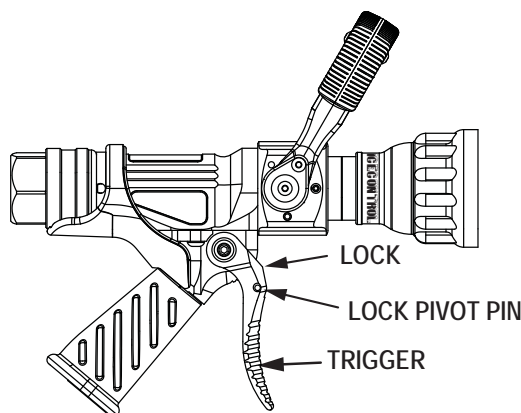

To Lock: Push on the lock while pulling back the trigger to engage one of the four locked positions.

To Un-Lock: Pull back slightly on trigger without any pressure on the lock. The spring loaded lock should automatically move to the unlocked position.

If the lock is not desired use an 1/8" (3mm) punch to push out pin and remove lock

WARNING

When the trigger lock is engaged, the nozzle will not shut off if dropped. Always shut off nozzle before releasing the pistol grip to avoid injury from an out of control nozzle.

4.1.2.2. IMPULSE TRIGGER FLOW CONTROL SPEED ADJUSTMENT

The IMPULSE valve contains a slow close mechanism to prevent the nozzle from slamming off if the trigger is suddenly released. The closing speed is set at the factory to be slow enough to reduce water hammer, (“water hammer” is always present in any valve when it is shut off. The slow close mechanism will reduce this but cannot eliminate it completely) but fast enough to reduce the potential danger of hose whipping from a dropped nozzle. The closing speed may be adjusted as shown in the figure. 4.1.2.2.

Do not unscrew the adjuster past the end of the hand grip (to unscrew it too far could result in the loss of dampening fluid.)

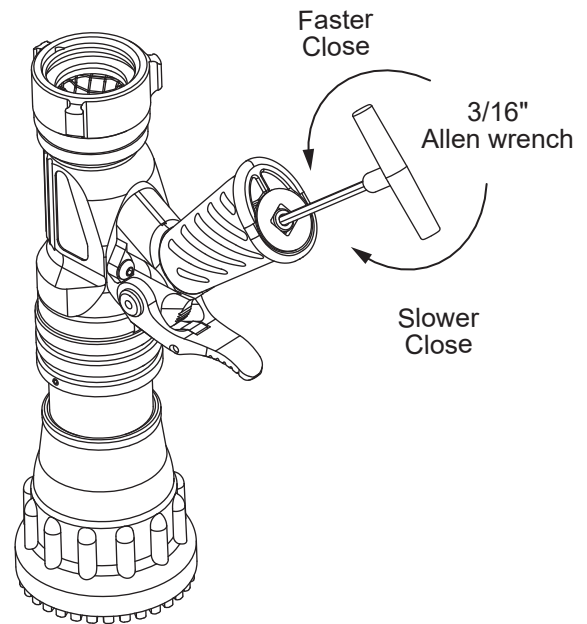
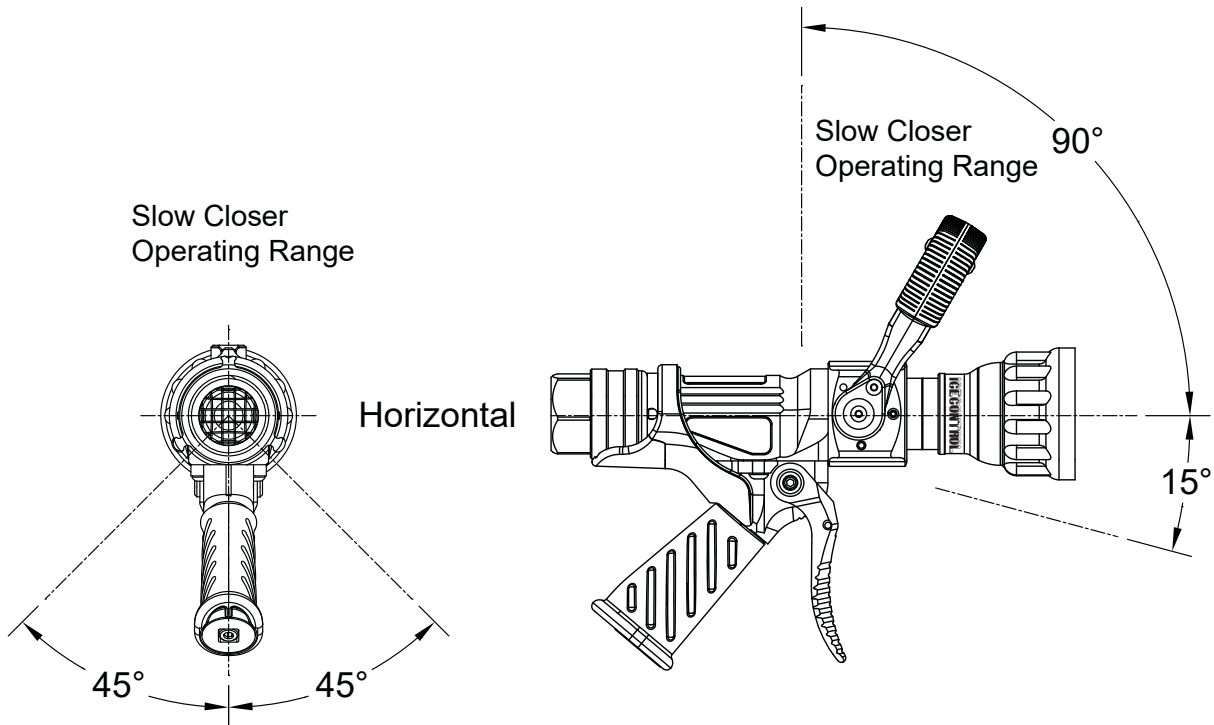

Figure 4.1.2.2



As the closing time is increased so does the risk of injury from an out of control nozzle. A flowing nozzle can cause injury within the first second of lost control. Use caution when adjusting the closing speed and always verify performance after adjustment.

4.1.2.3 NORMAL OPERATING POSITION



The Slow Close Feature relies on a fluid and air combination in the pistol grip. For proper function, the pistol grip should be within its normal operating position. The normal operating position is with the nozzle horizontal or pointing up with the pistol grip within 45 degrees of vertical. Releasing the trigger suddenly outside of the normal orientation will likely result in faster shut-off causing a higher pressure spike and increasing the risk of a burst hose. Do not suddenly release the trigger when operating outside of the nozzle’s normal orientation.

4.1.2.4 SETTING FIXED HANDLE POSITION

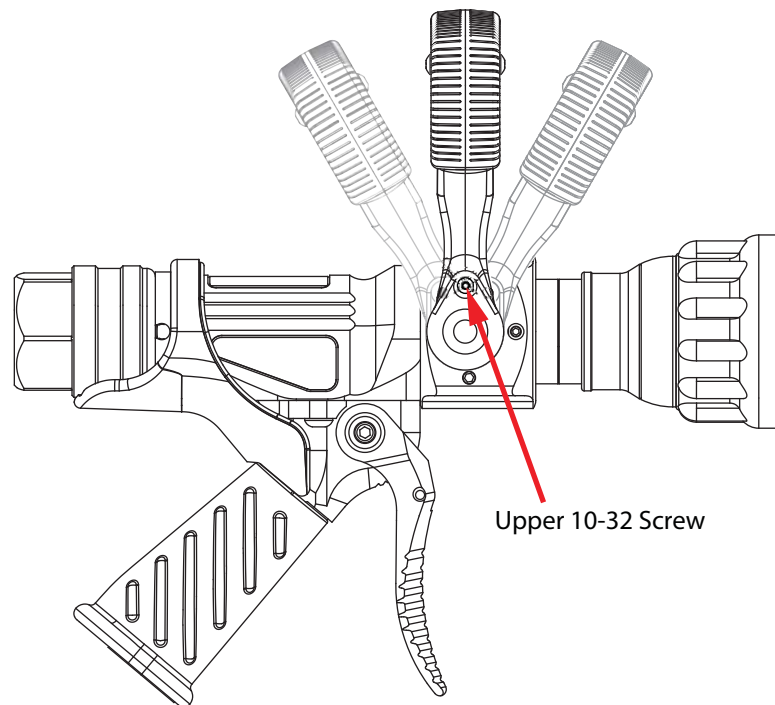

The fixed handle may be used to counteract nozzle reaction forces, but it does not control flow since it is not part of the valve. The handle can be set into any of three positions based on user preference.

To set the handle position;

1. Remove the upper 10-32 button head screws located on both sides of the handle using 1/8" hex key.
2. Position the handle into the desired position, apply Loctite 242 (blue) to the screws. Tighten securely.

4.1.3 ELECTRIC REMOTE NOZZLES

On models with electric remote control of the shaper there is no built-in flow control. Flow control must be provided for elsewhere in the system.

4.2 PATTERN AND FLUSH CONTROL

4.2.1 PATTERN CONTROL

4.2.1.1 MANUAL PATTERN CONTROL

On models that use a twist-type pattern control, a continuously variable pattern from narrow to wide is available. Turning the SHAPER clockwise, as seen from the operating position behind the nozzle, moves the SHAPER to the straight stream position. Turning the SHAPER counterclockwise will result in an increasingly wider pattern. An indicator band on the nozzle barrel shows which position the SHAPER is in by progressively uncovering symbols for FLUSHING, WIDE SPRAY and STRAIGHT STREAM.

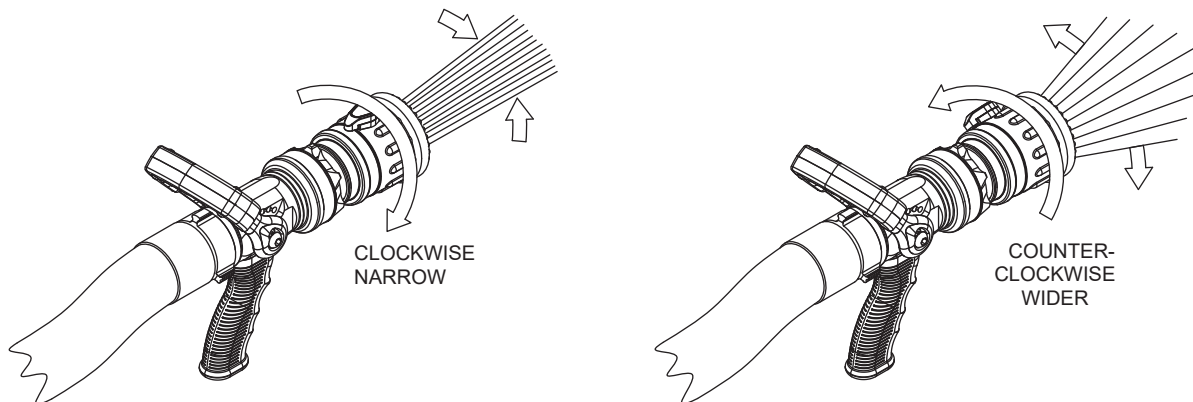

4.2.1.2 ELECTRIC PATTERN CONTROL

On models that use an electric pattern control, a continuously variable pattern from narrow to wide is available by operating the electric actuator according to the directions supplied with the actuator control panel. Extending the SHAPER outwards, as seen from behind the nozzle, moves the SHAPER to the straight stream position. Retracting the SHAPER inwards will result in an increasingly wider pattern. The actuator detects the motor current rise at each end of its stroke and stops the motor instantly, thus making limit switches unnecessary. Manual override is possible by using the external knob or hex head to drive the motor shaft. Turning the shaft counterclockwise, as seen from the operating position behind the nozzle, extends the SHAPER towards the straight stream position. Turning the knob clockwise retracts the SHAPER towards the wide spray position. If a 5/16" hex wrench is used, do not force the shaft further after it stops firmly at each end of stroke. Exceeding 40 in-lb (4.5 N m) will damage the actuator.

CAUTION

Electric remote nozzle has finger pinch points. Keep fingers away from nozzle when using electric control.

4.2.2 FLUSH CONTROL

Small debris may get caught inside the nozzle. This trapped material will cause poor stream quality, shortened reach, and reduced flow. To remove small debris, the nozzle may be flushed as follows:

- While still flowing, rotate the shaper counterclockwise (as viewed from behind the nozzle) to the flush position. (Increased resistance will be felt on the shaper as the nozzle goes into flush) This will open the nozzle allowing debris to pass through.
- During flush the nozzle reaction will decrease as the pattern becomes wider and the pressure drops. The nozzle operator must be prepared for an increase of nozzle reaction when returning the nozzle from the flush position to retain control of the nozzle.
- Rotate the shaper out of flush to continue normal operations.

WARNING

Debris in nozzle can result in ineffective stream. Flush or uncouple nozzle to remove debris. Remove all pressure and flow from the nozzle before uncoupling.

CAUTION

Heated ice-control fluids are capable of causing burns. Direct stream away from personnel when flushing as hot fluid may splash to the ground directly under the nozzle.

4.2.2.1 VALVED NOZZLE FLUSHING

While still flowing fluid, turn the SHAPER counterclockwise past the wide spray position (increased resistance to turning will be felt on the SHAPER as the nozzle goes into flush.) This will open the nozzle allowing debris to pass through. Rotate the SHAPER clockwise and out of flush to continue normal operation. During flush, the nozzle will lose much of its reaction force and reach as the pressure drops. The nozzle operator must be prepared for an increase in reaction, reach and pressure when returning the nozzle from the flush position to normal operation to retain control of the nozzle and stream. Operating the nozzle in the flush position will flow increased volumes of fluid. Operate in the flush position only when necessary and only for a short amount of time to prevent fluid waste.

4.2.2.2 ELECTRIC REMOTE FLUSHING

While still flowing fluid, retract the SHAPER backwards past the wide spray position (as viewed from behind the nozzle) until it reaches its stop. This will open the nozzle allowing debris to pass through. When the debris has been flushed out, extend the SHAPER outwards until it is out of flush as determined by the markings on the barrel and the force of the stream to continue normal operation. Flushing may also be accomplished in the manual override mode of operation by moving past the wide spray position. See 4.2.1.2 for instruction on how to use manual override. During flush, the nozzle will lose much of its reaction force and reach as the pressure drops. Operating the nozzle in the flush position will flow increased volumes of fluid. To prevent fluid waste, only operate in the flush position when necessary to pass debris.

5.0 USE OF ICE-CONTROL NOZZLES

IT IS THE RESPONSIBILITY OF THE GROUND CREW MANAGEMENT TO DETERMINE PHYSICAL CAPABILITIES AND SUITABILITY FOR AN INDIVIDUAL'S USE OF THIS EQUIPMENT.

The methods used in applying ice-control fluids to aircraft are the responsibility of the agency performing the ice-control fluid application. Many factors contribute to the proper control of ice on an aircraft. The nozzle is only one part of a complete ice control system. Flow, pressure at the nozzle, fluid temperature, type of fluid, method of application, outside air temperature, precipitation, aircraft surface temperature and other factors must be taken into account when dealing with ice conditions. The proper methods must be determined by each agency for their particular conditions.

Where a nozzle is listed as Anti-icing capable, flow and pressure must be controlled within the rating of the nozzle to minimize shearing degradation of the fluid.

⚠ WARNING Discharge of anti-icing fluids from nozzles at flows higher than 50 GPM or 85 psi may result in degradation of the fluid and render it ineffective in preventing a buildup of ice on aircraft surfaces prior to takeoff. Consult fluid manufacturer's recommended guidelines.

Rated fluid temperatures at the nozzle must not be exceeded. Use of saltwater in these nozzles is not permissible and will lead to a shortened service life. Some features of this nozzle that the operator should be aware of are:

- **Automatic Pressure Control for deicing** - When used for deicing, these nozzles from Task Force Tips incorporate a pressure regulating mechanism, which means the fluid discharge velocity is nearly constant. With a constant nozzle discharge pressure, the deicing agent will have optimum reach at all flow settings, thereby reducing waste due to insufficient range of the stream.
- **Slide-Type valve with heat resistant EPDM seat** - On nozzles with a valve, the valve design controls the flow through the nozzle while minimizing turbulence that causes shear and degradation of anti-icing fluids. Because of this feature, the nozzle can be operated at any valve handle position, thereby allowing the operator to regulate the amount of agent being applied. This gives the operator the ability to conserve fluid and minimize waste without sacrificing reach or range of the stream. Unlike a ball valve, the stainless steel slide valve is not directly in the flow path and will not tighten under pressure, or bind with age. Therefore, it remains easy to operate.
- **Pattern Control** - This nozzle features a "toothless" bumper to reduce turbulence and can be adjusted for any desired spray pattern by moving the shaper between a straight stream or wide spray position.
- **Sealed electric motor with easy-to-use manual override** - On electric remote models, the nozzle is equipped with a sealed motor/gear housing which prevents contamination of the actuator with dirt and fluids. The actuator features an override mechanism to allow manual setting of the pattern or to place the nozzle into flush mode.
- **Flushable while flowing** - The nozzle shaper, when retracted fully, puts the nozzle into flush, providing an oversized fluid passageway which helps trapped debris to exit the nozzle. On manual models, an increase in turning force on the shaper signals the operator that the nozzle is moving into flush.

⚠ DANGER An inadequate supply of nozzle pressure and/or flow will cause an ineffective stream and can result in incomplete removal or incomplete protection from the build-up of ice on flight surfaces which may lead to injury, death or loss of property. Call 800-348-2686 for assistance.

⚠ WARNING Ice-control fluid streams are capable of injury and damage. Heated streams can cling to and burn unprotected flesh and eyes. Do not direct fluid stream or allow splash to cause injury to persons or property.

⚠ WARNING Failure to restrain nozzle reaction can cause injury from loss of footing and/or whipping. With handheld nozzles, the nozzle operator must always be positioned to restrain the nozzle reaction in the event of those changes. In case of whipping, retreat from the nozzle immediately. Do not attempt to regain control of nozzle while flowing fluid.

⚠ WARNING Breathing ice-control fluid fumes can be hazardous to your health. Avoid working downwind. Avoid splash back. Consult fluid manufacturer's safety guidelines.

6.0 FIELD INSPECTION

Task Force Tip's Ice-Control Nozzles are designed and manufactured to be damage resistant and require minimal maintenance. However, as the primary fluid application tool upon which aircraft ice-control depends, they should be treated accordingly.

WARNING

Nozzle must be periodically inspected for proper operation and function according to Inspection Checklist in section 10.0. Any nozzle that fails inspection is dangerous to use and must be repaired before using.

Performance tests shall be conducted on Ice-Control nozzles after repair, or anytime a problem is reported to verify operation in accordance with TFT test procedures. Consult factory for the procedure that corresponds to the model and serial number of the nozzle. Any equipment which fails the related test criteria should be removed from service immediately. Equipment can be returned to the factory for service and testing.

Factory service is available with repair time seldom exceeding one day in our facility. Factory serviced nozzles are repaired by experienced technicians to original specifications, fully tested and promptly returned. Any returns should include a note as to the nature of the problem, who to reach in case of questions and if a repair estimate is required. A service request form is available on our website, www.tft.com.

Repair parts are available for those wishing to perform their own repairs. Task Force Tips assumes no liability for damage to equipment or injury to personnel that is a result of user service.

CAUTION

Any alterations to the nozzle and its markings could diminish safety and constitutes a misuse of this product. Do not alter the nozzle or its markings.

All Task Force Tip nozzles are factory lubricated with high quality silicone grease. This lubricant has excellent washout resistance and long term performance. If your operation has unusually hard or sandy water, the moving parts may be affected.

The moving parts of the nozzle should be checked on a regular basis for smooth and free operation, and signs of damage. **IF THE NOZZLE IS OPERATING CORRECTLY, THEN NO ADDITIONAL LUBRICATION IS NEEDED.** Any nozzle that is not operating correctly should be immediately removed from service and the problem corrected.

6.1 FIELD LUBRICATION PROCEDURE

The field use of Break Free CLP (spray or liquid) lubricant will help to restore the smooth and free operation of the nozzle. However, these lubricants do not have the washout resistance and long-term performance of the silicone grease. Therefore, re-application of Break Free CLP will be needed on a regular basis. CAUTION: Aerosol lubricants contain solvents that can swell O-Rings if applied in excess. The swelling can inhibit smooth operation of the moving parts. When used in moderation, as directed, the solvents quickly evaporate without adversely swelling the O-Rings.

Valved nozzle shown. Use similar procedures for trigger nozzles. The nozzle can be returned to the factory for a complete checkup and re-lubrication with silicone grease.

PART ONE — COUPLING DOWN

Position the nozzle at a 45-degree angle with the COUPLING end down. CLOSE the valve handle and set the pattern to STRAIGHT STREAM. Then spray a short burst into these areas:

#1 FRONT PATTERN CONTROL SEAL

Spray in between the pattern control and the barrel.

#2 PRESSURE CONTROL UNIT

Place check sticks behind baffle while shaper is in flush. Cycle baffle in and out using check sticks several times to work lubrication into o-rings.

#3 FRONT SLIDER SEAL

- Rotate shaper into FLUSH position.
- Spray down the front end of the nozzle to dribble lubricant into the clearances between the shaper and the valve body.

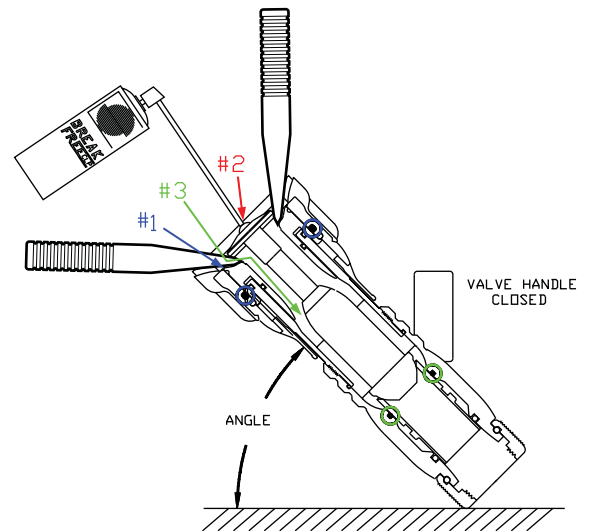

While holding nozzle at the angle, wait 30 seconds for the lubricant to penetrate into the clearances. Cycle the valve handle and rotate the shaper from straight stream to full flush several times, and then proceed to the next section.

PART TWO — COUPLING UP

Position the nozzle at a 45-degree angle with the BUMPER end down. OPEN the valve handle and set the pattern to FLUSH. Spray a short burst in these areas:

#4 REAR SHAPER SEAL

Spray down the clearance between the label and the shaper guide.

#5 REAR SLIDER SEAL

Spray into the clearance between the slider and the valve body.

#6 FLUSH MECHANISM SEAL

- With the handle on the top, spray down into the nozzle. The aerosol extension tip will help direct the spray into clearances leading to the O-Ring.
- Rotate nozzle so the valve is on the bottom and spray another short burst.

#7 DETENTS IN THE HANDLE

Spray a small amount on the detent followers located in the handle.

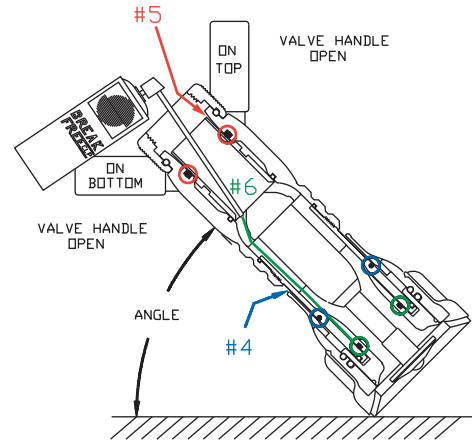

While holding nozzle at the angle, wait 30 seconds, then cycle the valve handle several times. Rotate the pattern control from straight stream to full flush several times. The pattern control should move freely and easily. The barrel cone should move forward to within 1/16" of the baffle before the shaper reaches straight stream position. Wipe off excess lubricant.

IF THIS PROCEDURE DOES NOT RESTORE SMOOTH AND FREE OPERATION OF ALL THE MOVING PARTS, THEN FACTORY SERVICE IS NEEDED. • 24-HOUR HOT LINE — 800-348-2686 • www.tft.com

7.0 PARTS LIST

7.1 ICE-CONTROL NOZZLE VALVED MODELS

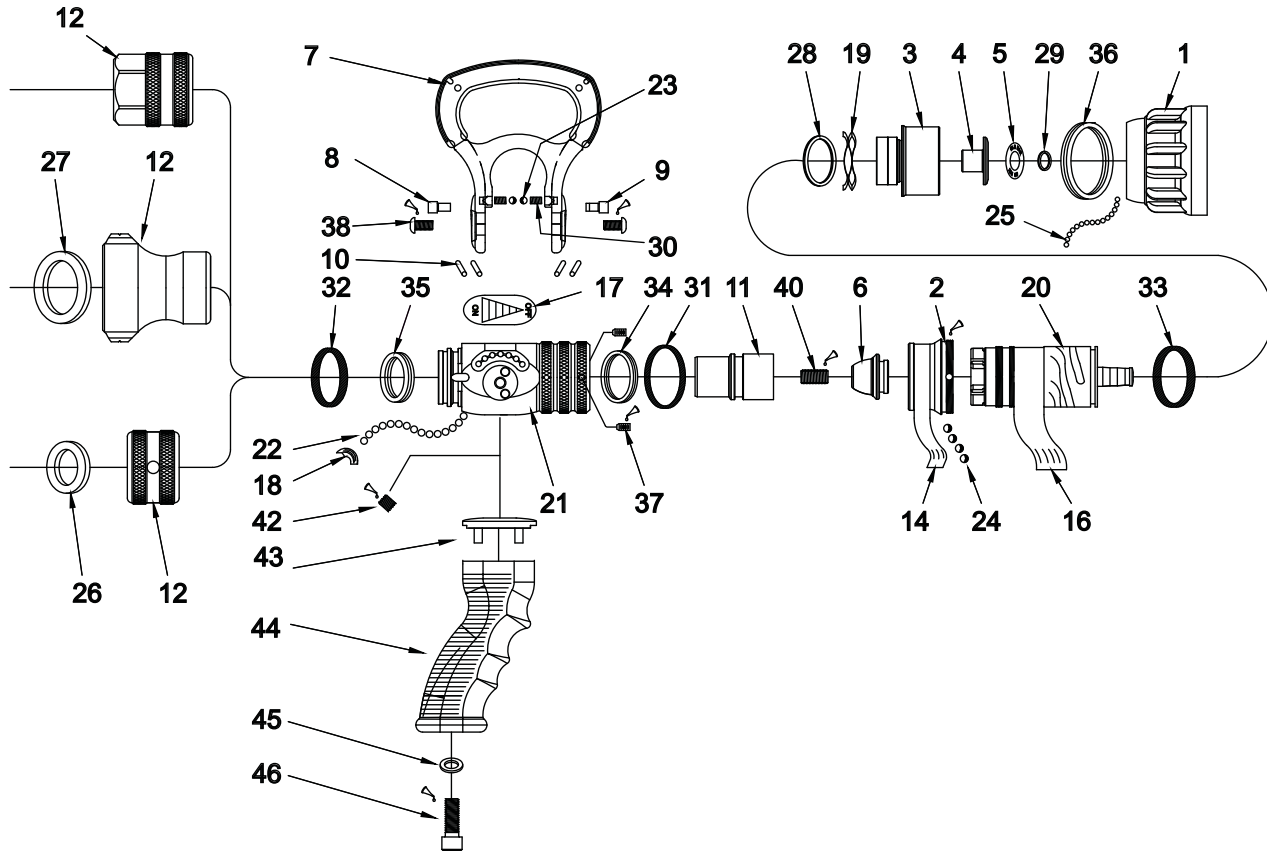

REF#	QTY	DESCRIPTION	PART #	(g) BH-HT100-PD (h) BGH-HT120-PD (i) BGH-HT150-PD (j) BH-HT150-PD (l) BH-HT120-PD (m) BH-HT120-IF (o) BGH-HT1502PD (p) BGH-HT1503PD
1	1	BUMPER NO TEETH	B504	
2	1	SHAPER GUIDE	B510	
3	1	BARREL CONE	B524	
4	1	BAFFLE	B560	
5	1	SPRING WASHER 75 PSI	B567 (e,n)	
	1	SPRING WASHER 50 PSI	B568 (a,b,c,d,k)	
	1	WASHER	B561 (o)	
	1	WASHER 20GPM @ 50PSI & 80GPM @ 120PSI	B563 (h,l,m)	
	1	SPRING WASHER 100 PSI	B565 (f,g)	
	1	SPRING WASHER 150 PSI	B566 (i,j)	
	1	150 PSI SPRING WASHER	B559 (p)	
6	1	HIGH-TEMP NOSE CONE	B594	
7	1	WIDE HANDLE	B622	
	4	#8-32X3/8 BUTTON HEAD SCREW	VT08E32BH375	
	2	HANDLE COVER	HM625-BLK	
8	1	CAM SCREW	B630	
9	1	SAFETY SCREW	B635	
10	4	DRAG NUBS	B650	

— Continued on next page —

REF#	QTY	DESCRIPTION	PART # a) BGH-HT50 (b) BH-HT50 (c) BGH-HT50-DS (d) BGH-HT50-PD (e) BGH-HT75-PD (k) BH-HT50-IF (n) BH-HT75 (f) BGH-HT100-PD	(g) BH-HT100-PD (h) BGH-HT120-PD (i) BGH-HT150-PD (j) BH-HT150-PD (l) BH-HT120-PD (m) BH-HT120-IF (o) BGH-HT1502PD (p) BGH-HT1503PD
11	1	SPECIAL AGENT SLIDER	B662	
12	1	1.0" TAPER PIPE COUPLING	B668 (d,e,f,g,h,i,l,o)	
	1	1.5" NH ROCKER LUG	B694N (a,b,n)	
	1	1.5" NPSH ROCKER LUG	B694I (k,m)	
	1	CODE DS COUPLING 1 5/16-12	B680DS (c)	
14	1	NAME LABEL - ICE CONTROL	B727	
16	1	BARREL LABEL	B740	
17	1	VALVE LABEL	B750	
18	1	PORT PLUG	B770	
19	1	FLUSH WAVE SPRING	B785	
20	1	BARREL	B540	
	1	SHAFT	B570 (e,f,g,h,i,j,l,m,n,o,p)	
	1	TYPE 2 SHAFT	B574 (a,b,c,d,k)	
	1	HIGH TEMP SPRING CAN	B584	
	1	CONTROL SPRING 100 PSI	B760 (a,b,c,d,f,g,h,i,k,l)	
	1	FORESTRY SPRING 75 PSI	B765 (e,n)	
	1	CONTROL SPRING 150 PSI	B766 (i,j)	
	1	CONTROL SPRING 1502	B767 (o)	
1	150 PSI SPRING SPACER	B572 (h,i,j,l,m,o,p)		
21	1	VALVE ASSEMBLY	B910	
22	28	3/16" DIA. STAINLESS BALL	V2120	
23	2	3/16" DIA. TORLON BALL	V2120-TORLON	
24	4	SHAPER BULLETS	B501	
25	46	1/8" DIA. NYLON BALL	V2135	
26	1	1.0" COUPLING GASKET	V3040	
27	1	1.5" COUPLING GASKET	V3130	
28	1	WS-128-F-S02 SMALLEY RING	V4270	
29	1	WSM-50-S02 SMALLEY RING	V4280	
30	2	SPRING #C0180-032-0310-S	VM4195	
31	1	O-RING-030	VO-030	
32	1	O-RING-127	VO-127	
33	1	O-RING-128	VO-128	
34	1	QUADX-4124	VOQ-4124	
35	1	QUADX-4216	VOQ-4216	
36	1	QUADX-4225	VOQ-4225	
37	2	#10-32 x 3/16" SOCKET SET SCREW	VT10Y32SS187	
38	2	5/16-18 x 1/2" BUTTON HEAD	VT31E18BH500	
40	1	HI TEMP NOSE CONE INSERT PLUG	B599	
42	1	3/8-16 X 5/16 SOCKET SET	VT37-16SS312	
43	1	GRIP SPACER - ULTIMATIC	HM693-U	
44	1	PISTOL GRIP - BLACK	HM692-BLK	
	1	GRIP COLOR CODED SUBASSEMBLY RED W/ YELLOW & GREEN W/YELLOW STRIPE	HM990U-RED-Y AND HM990U-GRN-Y	
45	1	WASHER	VM4901	
46	1	3/8-16 X 1.00 SHCS	VT37-16SH1.0	

7.2 ICE-CONTROL IMPULSE TRIGGER NOZZLE MODELS

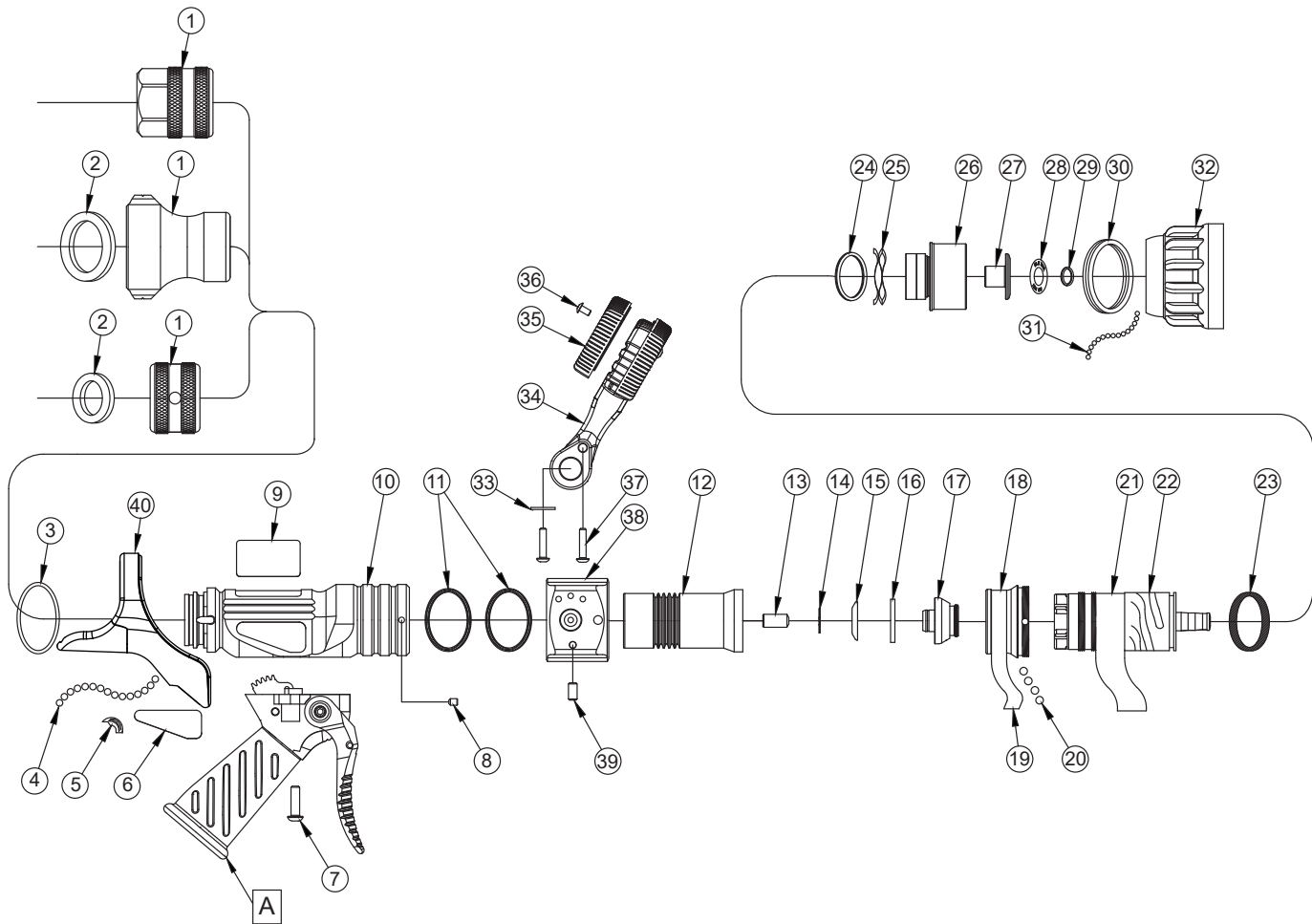

INDEX	DESCRIPTION	QTY.	PART #
1	1.0" TAPER PIPE COUPLING	1	B668
	1.5" NH ROCKER LUG		B694N
	1.5" NPSH ROCKER LUG		B694I
	CODE DS COUPLING 1 5/16-12		B680DS
2	1.0" COUPLING GASKET	1	V3040
	1.5" COUPLING GASKET		V3130
3	O-RING 127	1	VO-127
4	3/16" SS BALL	28	V2120
5	PORT PLUG	1	B770
6	LABEL: LEFT	1	TN600LL
	LABEL: RIGHT	1	TN600LR
7	1/4-20 X 7/8 BUTTON HEAD SCREW	2	VT25-20BH875
8	10-32 X 3/16 SOCKET SET SCREW	2	VT10-32SS187
9	LABEL: TOP	1	TN600LT
10	VALVE BODY	1	TN600B
11	QUAD-RING 4125	2	VOQ-4125
12	ICE-CONTROL SLIDER	1	TN661B
13	3/8-24 X 3/4 SOCKET SET SCREW	1	VT37-24SS750
14	WSM-62 SMALLEY RING	1	VR4375
15	RETAINER	1	TN595
16	VALVE GASKET	1	TN591

INDEX	DESCRIPTION	QTY.	PART #
17	VALVE PLUG CONE	1	TN594
18	SHAPER GUIDE	1	B510
19	NAME LABEL - ICE CONTROL	1	B727
20	SHAPER BULLETS	4	B501
21	BARREL LABEL	1	B740
22	BARREL	1	B540
	SHAFT	1	B570
	TYPE 2 SHAFT	1	B574
	HIGH TEMP SPRING CAN	1	B584
	CONTROL SPRING 100 PSI	1	B760
	FORESTRY SPRING 75 PSI	1	B765
	CONTROL SPRING 150 PSI	1	B766
	CONTROL SPRING 1502	1	B767
	150 PSI SPRING SPACER	1	B572
	O-RING 115	1	VO-115
WSM-50-S02 SMALLEY RING	1	V4280	
23	O-RING-128	1	VO-128
24	WS-128-F-S02 SMALLEY RING	1	V4270
25	FLUSH WAVE SPRING	1	B785
26	BARREL CONE	1	B524
27	BAFFLE	1	B560
28	SPRING WASHER 75 PSI	1	B567
	SPRING WASHER 50 PSI		B568
	SPRING WASHER 20 GPM & 50 PSI/40 GPM @ 150 PSI		B561
	SPRING WASHER 20 GPM @ 50 PSI/80 GPM @ 120 PSI		B563
	SPRING WASHER 100 PSI		B565
	SPRING WASHER 150 PSI		B566
	SPRING WASHER 20-25 GPM @ 150 PSI		B559
29	WSM-50-S02 SMALLEY RING	1	V4280
30	QUAD-RING 4225	1	VOQ-4225
31	.119" DIA. NYLON BALL	46	VB119NY
32	BUMPER NO TEETH	1	B504
33	WASHER STAINLESS	2	VW700X203-60
34	140 SHUTOFF HANDLE	1	F14060
35	HANDLE COVER	2	HM625*
36	8-14 X 3/8 PUSHTITE BUTTON HEAD	4	VT08-14PT375
37	10-32 X 7/8 BUTTON HEAD CAP SCREW	4	VT10-32BH875
38	HANDLE MOUNT	1	TN602
39	1/4-20 X 1/2 SOCKET SET SCREW CUP POINT	2	VT25-20SS500
40	HEAT SHIELD	1	TN605
A	TRIGGER GRIP SUBASSEMBLY	1	TN900
	HIGH PRESSURE TRIGGER GRIP SUBASSEMBLY		TN900HP
	EXTENDED TRIGGER GRIP SUBASSEMBLY		TN900ET
* Contact TFT for Different Handle Cover Colors			

7.3 ICE-CONTROL NOZZLE ELECTRIC REMOTE MODEL

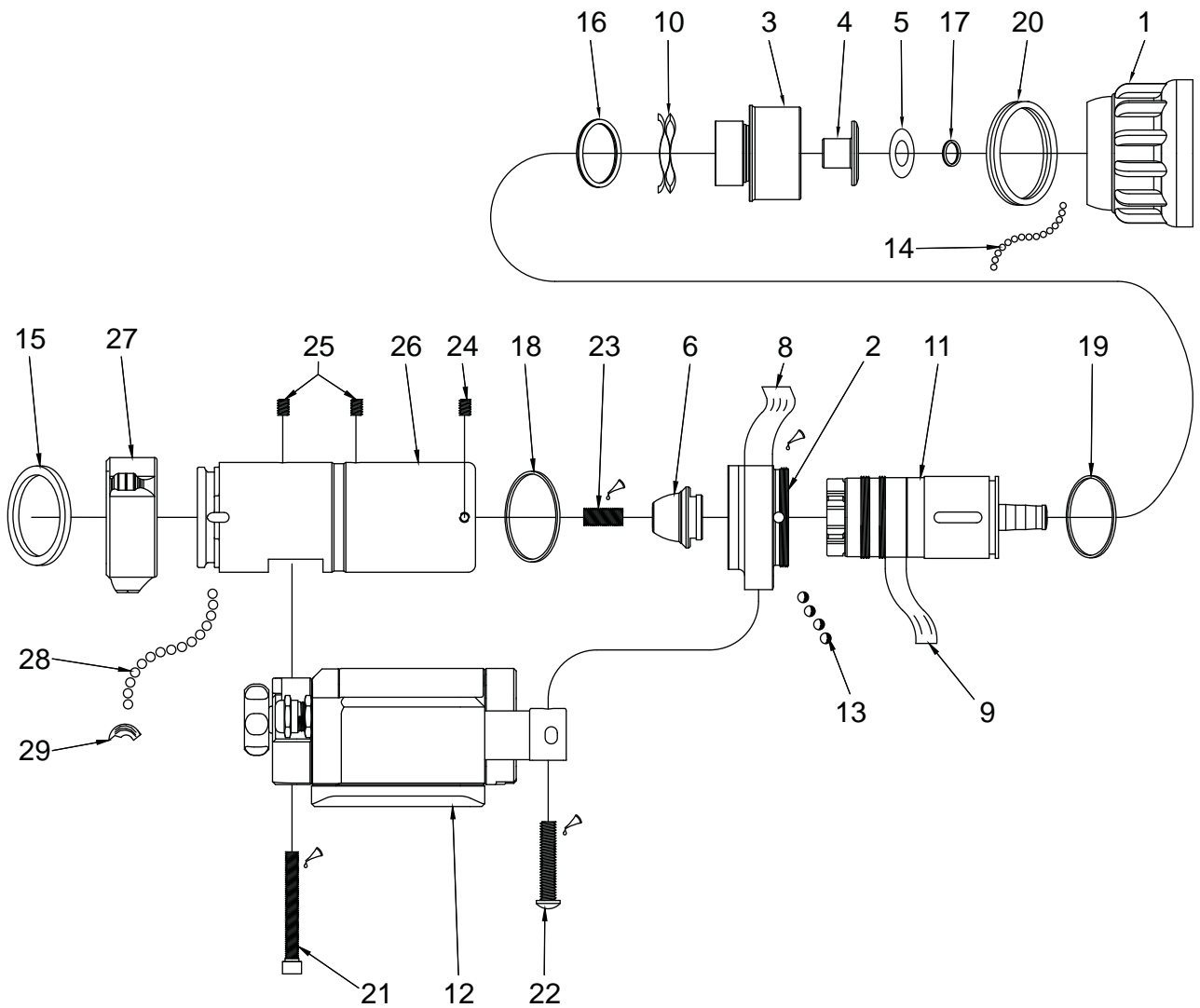

REF#	QTY	DESCRIPTION	PART # (a) BER-HT75 (b) BER-HT120 (c) BER-HT150	(d) BER-HT1501 (i) BER-HT1502 (j) BERP-HT150
1	1	BUMPER / NO TEETH	B504	
2	1	ER SHAPER GUIDE	B514	
3	1	BARREL CONE	B524	
4	1	BAFFLE	B560	
5	1	75 PSI SPRING WASHER	B567 (a)	
	1	WASHER 20GPM @ 50PSI & 80GPM @ 120PSI	B563 (b)	
	1	150 PSI SPRING WASHER	B566 (c,j)	
	1	SPRING WASHER - SPECIAL	B562 (d)	
	1	WASHER 20GPM@50PSI 40GPM@150PSI	B561 (i)	
6	1	HIGH TEMP NOSE CONE	B597	
7	1	ER T.O. BASE - LASERED	B664	
8	1	ICE-CONTROL NAME LABEL	B727	
9	1	BARREL LABEL	B740	
10	1	FLUSH WAVE SPRING	B785	

— Continued on next page —

REF#	QTY	DESCRIPTION	PART # (a) BER-HT75 (b) BER-HT120 (c) BER-HT150	(d) BER-HT1501 (i) BER-HT1502 (j) BERP-HT150
11	1	LINEAR BARREL	B544	
	1	SHAFT	B570	
	1	HI-TEMP SPRING CAN	B584	
	1	SPRING SPACER - .100 THICK	B572 (b,c,d,i,j)	
	1	SPRING 80 GPM @ 120 PSI	B763 (b)	
	1	FORESTRY SPRING 75 PSI	B765 (a)	
	1	CONTROL SPRING 150 PSI	B766 (c,d,j)	
	1	CONTROL SPRING 1502	B767 (i)	
	1	O-RING-115	VO-115	
12	1	ACTUATOR ULTIMATIC 2-WIRE - SUBASSEMBLY	Y6201-B	
	1	ACTUATOR ULTIMATIC 6-PIN PLUG- SUBASMBLY	Y6200-B	
13	4	SHAPER BULLETS	B501	
14	46	1/8 BALL - #101 NYLON	V2135	
15	1	COUPLING GASKET 1.5"	V3130	
16	1	WS-128-F-S02 SMALLEY RING	V4270	
17	1	WSM-50-S02 SMALLEY RING	V4280	
18	1	O-RING-030	VO-030	
19	1	O-RING-128	VO-128	
20	1	QUAD RING-225	VOQ-4225	
21	2	1/4-20 x 2-1/4 SOCKET HEAD CAP SCREW	VT25-20SH2.2	
22	1	5/16-18 x 1-7/16 BUTTON HEAD CAP SCREW	VT31-18BH1.4	
23	1	3/8-24 X 3/4 SOCKET SET SCREW	VT37-24SS750	
24	2	10-32 X 1/4 SOCKET SET SCREW NYLON PATCH	VT10Y32SS250	
25	2	1/4-20 X 3/8 SOCKET SET SCREW	VT25-20SS375	
26	1	BASE ER SWIVEL	B663	
27	1	1.5"NH ROCKER LUG	F10097N	
28	34	3/16" DIA. STAINLESS BALL	V2120	
29	1	PORT PLUG	B770	

7.4 12-24V ACTUATOR ASSEMBLY

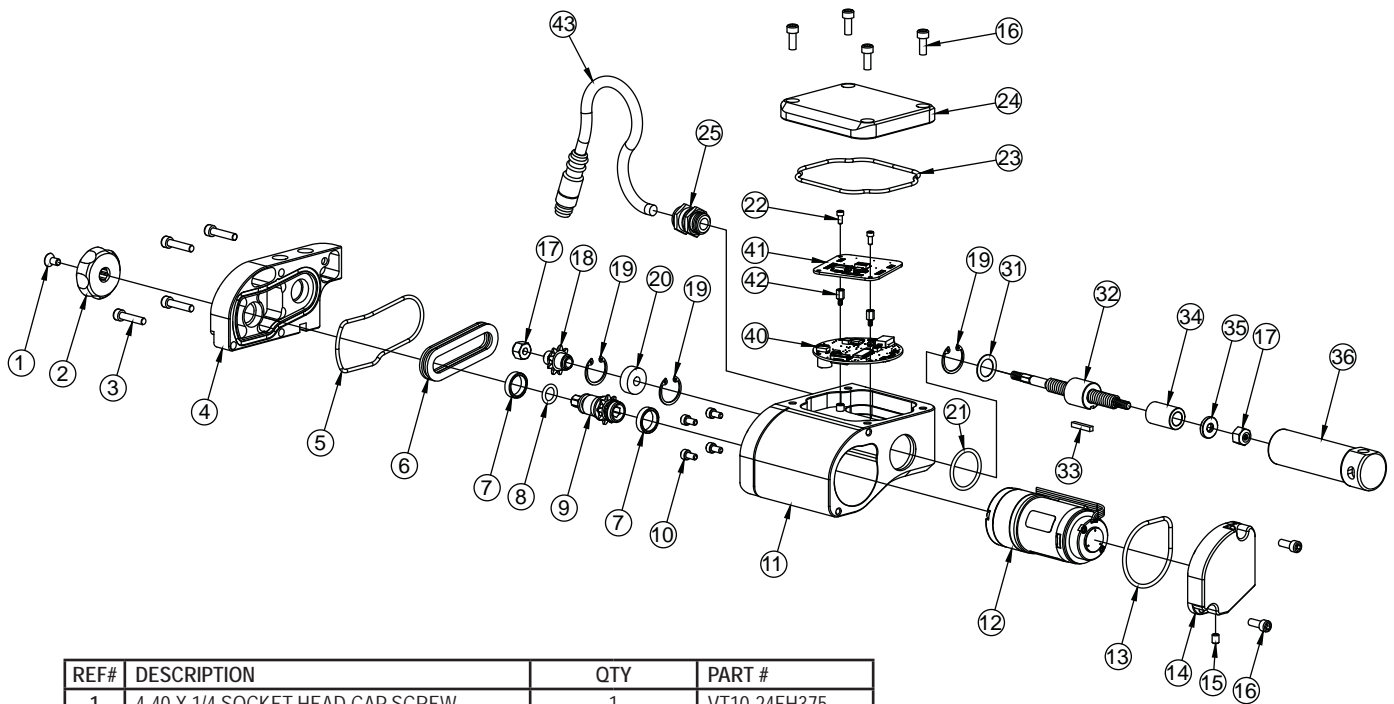

REF#	DESCRIPTION	QTY	PART #	
1	4-40 X 1/4 SOCKET HEAD CAP SCREW	1	VT10-24FH375	
2	KNOB	1	Y6112	
3	10-32 X 7/8 SOCKET HEAD SCREW	4	VT10-32SH875	
4	CHAIN COVER SMALL	1	Y6142	
5	O-RING-146	1	VO-146	
6	24 LINK ROLLER CHAIN S.S. SUBASSEMBLY	1	Y6140	
7	BUSHING MOTOR SPROCKET LARGE	2	Y6111	
8	O-RING-010	1	VO-110	
9	MOTOR SPROCKET	1	Y6110	
10	M4-0.7 X 8MM SOCKET HEAD SCREW	4	VTM4-0.7SH8	
11	HOUSING SMALL	1	Y6141	
12	GEAR MOTOR WITH ENCODER	1	Y6000	
13	O-RING-133	1	VO-133	
14	ENCODER COVER SMALL	1	Y6144	
15	10-32 X 1/4 SET SCREW - NYLON	1	VT10Y32SS250	
16	10-32 X 1/2 SOCKET HEAD SCREW	6	VT10-32SH500	
17	#12-24 HEX LOCK NUT	2	VT12-24LNT	
18	SPROCKET OUTPUT	1	Y6113	
19	SNAP RING 3/4 BORE	3	VR4210	
20	BEARING R4A-2RS	1	VM4232	
21	O-RING-120	1	VO-120	
22	4-40 X 1/4 SOCKET HEAD SCREW	2	VT04-40SH250	
23	O-RING-152	1	VO-152	
24	ELECTRONICS COVER SMALL	1	Y6143	
25	STRAIN RELIEF	1	Y6010	
31	WASHER	1	VW750X500-20	
32	LEADSCREW W/NUT	1	Y6100	
33	KEY	1	Y6121	
34	FRONT SPACER ULTIMATIC	1	Y6129	
35	FRONT STOP WASHER NO C'BORE	1	Y6122	
36	PISTON	1	Y6120	
SEE MODEL # ON BOTTOM OF ACTUATOR		Y6201-B	Y6200-B	
40	MOTOR CONTROL BOARD	1	NA	Y6020
41	VOLTAGE SUPPLY BOARD	1	NA	Y6025
	ACTUATOR ID BOARD	NA	1	Y5460-B
42	CIRCUIT BOARD STANDOFF	2	NA	Y5534
43	CABLE - 6 POLE MALE IN-LINE PLUG	NA	1	Y5480
	BLACK POWER CORD #18/2C 6 FT	1	NA	V4075

8.0 ANSWERS TO YOUR QUESTIONS

We appreciate the opportunity of serving you and making your job easier. If you have any problems or questions, our toll-free "Hydraulics Hotline", 800-348-2686, is normally available to you 24 hours a day, 7 days a week.

9.0 WARRANTY

Task Force Tips LLC, 3701 Innovation Way, Valparaiso, Indiana 46383-9327 USA ("TFT") warrants to the original purchaser of its Ice-Control series nozzles ("equipment"), and to anyone to whom it is transferred, that the equipment shall be free from defects in material and workmanship during the five (5) year period from the date of purchase.

TFT's obligation under this warranty is specifically limited to replacing or repairing the equipment (or its parts) which are shown by TFT's examination to be in a defective condition attributable to TFT. To qualify for this limited warranty, the claimant must return the equipment to TFT, at 3701 Innovation Way, Valparaiso, Indiana 46383-9327 USA, within a reasonable time after discovery of the defect. TFT will examine the equipment. If TFT determines that there is a defect attributable to it, TFT will correct the problem within a reasonable time. If the equipment is covered by this limited warranty, TFT will assume the expenses of the repair.

If any defect attributable to TFT under this limited warranty cannot be reasonably cured by repair or replacement, TFT may elect to refund the purchase price of the equipment, less reasonable depreciation, in complete discharge of its obligations under this limited warranty. If TFT makes this election, claimant shall return the equipment to TFT free and clear of any liens and encumbrances.

This is a limited warranty. The original purchaser of the equipment, any person to whom it is transferred and any person who is an intended or unintended beneficiary of the equipment, shall not be entitled to recover from TFT any consequential or incidental damages for injury to person and/or property resulting from any defective equipment manufactured or assembled by TFT. It is agreed and understood that the price stated for the equipment is in part consideration for limiting TFT's liability. Some states do not allow the exclusion or limitation of incidental or consequential damages, so the above may not apply to you.

TFT shall have no obligation under this limited warranty if the equipment is, or has been, misused or neglected (including failure to provide reasonable maintenance) or if there have been accidents to the equipment or if it has been repaired or altered by someone else.

THIS IS A LIMITED EXPRESS WARRANTY ONLY. TFT EXPRESSLY DISCLAIMS WITH RESPECT TO THE EQUIPMENT ALL IMPLIED WARRANTIES OF MERCHANTABILITY AND ALL IMPLIED WARRANTIES OF FITNESS FOR A PARTICULAR PURPOSE. THERE IS NO WARRANTY OF ANY NATURE MADE BY TFT BEYOND THAT STATED IN THIS DOCUMENT.

This limited warranty gives you specific legal rights, and you may also have other rights which vary from state to state.

10.0 INSPECTION CHECKLIST

Nozzle must be inspected periodically for proper operation and function according to this checklist periodically.

On models with a hand or trigger operated valve, check that:

- 1) There is no obvious damage such as missing, broken or loose parts, damaged labels, etc.
- 2) Coupling is tight and leak free.
- 3) Valve operates freely through full range of settings.
- 4) Trigger lock holds trigger open. (if so equipped)
- 5) "OFF" position does fully shut off and flow stops.
- 6) Nozzle flow is adequate as indicated by pump pressure and nozzle reaction.
- 7) Shaper turns freely and adjusts pattern through full range.
- 8) Shaper turns into full flush and out of full flush with normal flow and pressure restored.

On models with an electric remote control, check that:

- 1) There is no obvious damage such as missing, broken or loose parts, damaged labels, frayed or cracked wiring, etc.
- 2) Coupling is tight and leak free.
- 3) Nozzle flow is adequate as indicated by pump pressure and nozzle reach.
- 4) Shaper moves freely and adjusts pattern through full range by electric and manual control.
- 5) Shaper moves into full flush and out of full flush with normal flow and pressure restored by electric and manual control.
- 6) Electric remote actuator mountings are tight.
- 7) Manual override controls operate freely and through full range of motion.

WARNING

Any ice-control nozzle failing any part of the inspection checklist is unsafe. Correct this problem before use. Operating a nozzle that fails any of the above inspections is a misuse of this equipment.

All replacement parts must be obtained from the manufacturer to assure proper operation of the product, and to maintain approval of the device.

Made in USA
deicing.tft.com

TASK FORCE TIPS LLC
MADE IN USA • deicing.tft.com

3701 Innovation Way, Valparaiso, IN 46383-9327 USA
800-348-2686 • 219-462-6161 • Fax 219-464-7155