



A. INTRODUCTION

TASK FORCE TIP ULTIMATIC 125. The nozzle you have purchased is one of your primary tools in saving life and property. It has been manufactured with great care to give you the finest performance possible. All components are of top quality and extremely rugged. With regular inspection and maintenance it will serve you for many years. This publication is intended for those who prefer to perform service on their own equipment. Factory service is available and encouraged, and repair time seldom exceeds 24 hours in our facility. Factory serviced nozzles are repaired by experienced technicians, and fully tested before being returned. Task Force Tips assumes no liability, expressed or implied, for damage to equipment or injury to personnel that is a result of user service or improper usage, beyond that of repair or replacement.

AFTER ANY MAINTENANCE OR SERVICE, THE NOZZLE MUST BE INSPECTED FOR PROPER OPERATION AND FUNCTION PER 2.0 FLOW CHARACTERISTICS AND 9.0 INSPECTION CHECKLIST IN "TFT HANDHELD AUTOMATIC NOZZLE INSTRUCTIONS" (LIN-030). REQUEST ADDITIONAL COPIES FROM FACTORY IF NEEDED.

▲ WARNING: ANY NOZZLE THAT FAILS THE INSPECTION CHECKLIST IS UNSAFE AND MUST HAVE THE PROBLEM CORRECTED BEFORE USE. OPERATING A NOZZLE THAT FAILS ANY OF THE ABOVE INSPECTIONS IS A MISUSE OF THIS EQUIPMENT.

B. GENERAL INFORMATION

1.) **THREADED JOINTS** have been secured using Loctite #271 brand thread locking adhesive. Disassembly requires a minimal application of heat with a oxyacetylene torch to break the bond. The threads should be heated to approximately 450 F. Excessive heat application will cause damage to adjacent seals and labels. Replacement parts must be reinstalled using Loctite #271, or equivalent. Small vials of Loctite for field service are available; order part # V5010, LOCTITE MINI DISPENSER.

2.) **LUBRICANTS:** If parts are disassembled in an area where o-rings are present, re-assemble using DOW #44 High Temperature Silicone Grease on all o-rings and surfaces that the o-rings contact. If nozzle is not disassembled, Break Free CLP (Spray or Liquid) can be used as described below:

- a.) Spray clearance between SLIDER [17] and VALVE ASSEMBLY [12].
- b.) Spray clearance between SHAPER WITH BUMPER [54] and BARREL CONE ASSEMBLY [47].
- c.) Spray valve discs, then cycle the VALVE HANDLE [2] a few times to spread lubricant into clearances.
- d.) Spray lubricant down the front end of the nozzle through the hole in the shaft.
- e.) Spray ball race through clearance between coupling and valve.

▲ CAUTION: AEROSOL LUBRICANTS CONTAIN SOLVENTS THAT CAN SWELL O-RINGS IF APPLIED IN EXCESS. THE SWELLING CAN INHIBIT OPERATION OF THE MOVING

PARTS.

When used in moderation, as directed, the solvents quickly evaporate without adversely swellings the o-rings. For more lubrication information see the Task Force Tips Field Lubrication Procedure document #LIT-106.

3.) **LABEL REPLACEMENT:** If labels become damaged, remove old labels with razor knife. Remove adhesive with acetone or methyl ethyl ketone. Surface must be clean, dry and free from grease. Carefully apply new label.

4.) **ORDERING PARTS:** Always specify the serial number of the nozzle when ordering parts. The number is found on the raised rim of the SHAPER GUIDE [30]. Be sure to use complete DESCRIPTION and ORDER #, as printed on the parts list. All requests for couplings must specify thread size. Pricing information will be given at time of order.

C. COUPLING SERVICE

1.) **GENERAL:** Occasional replacement of hose gaskets is recommended. Replace GASKET GRABBER [9] if severe impact has caused damage.

2.) **COUPLING REMOVAL:** Remove PORT PLUG [19] from side of VALVE ASSEMBLY [12]. Stand nozzle upright with bumper down and rotate coupling back and forth to allow (28) 3/16" STAINLESS STEEL BALLS [18] to drop out. When all balls are out of the groove, the coupling can be removed. Remove GASKET GRABBER [9] debris screen and O-RING-127 [10] from the coupling. End pressure is needed to remove and install coupling balls.

3.) **COUPLING INSTALLATION:** Place O-RING-127 [10] onto the rear groove on valve body. Place the GASKET GRABBER [9] debris screen onto the valve body, raised end in. Put the coupling on the valve and load balls into the ballgroove through the port in the valve. Insertion of the balls is easier if the coupling is rotated slightly back and forth as the balls are loaded. Insert PORT PLUG [19] into port on side of VALVE ASSEMBLY [12].

4.) **TIP ONLY BASE SERVICE:** The TIP ONLY BASE [26] is retained to the front end by threads which are retained by Loctite. Apply heat to the knurled rib nearest the front of the nozzle. Damage to seals and labels can be reduced by protecting them with a wet cloth. The TIP ONLY BASE [26] can now be unscrewed. Remove and replace O-RINGS [10 and 16]. Clean all threads, apply Loctite to threads and screw together.

5.) **BOLT-ON PISTOL GRIP REMOVAL:** PISTOL GRIP [21] is held on by a SOCKET HEAD CAP SCREW [22]. Remove screw with a 5/16" Allen wrench. To reinstall, clean thread and apply Loctite #271. Tighten screw to 20 ft-lbs.

D. VALVE SERVICE PROCEDURE

Tools Required:
3/32" Allen (hex) Wrench
3/16" Allen (hex) Wrench
Loctite #271 Thread Locking Adhesive
Oxyacetylene Torch
Lubricant such as Dow Corning #44 Silicone Grease

1.) VALVE DISASSEMBLY SEQUENCE

- a.) **HANDLE REMOVAL:** Heat and then remove both 5/16-18

“ULTIMATIC 125” NOZZLE

Maintenance And Service Procedure For Nozzles With Serial Numbers Over TFTB-166900. For Nozzles Manufactured Prior To January 1995, And Before Serial Number TFTB-166900, Consult Service Department For Previous Edition Of This Document.

x 1/2 BUTTON HEAD SCREWS [4] from VALVE HANDLE [2] using 3/16" Allen wrench. Remove CAM PIN [3] and SAFETY PIN [7]. The handle may now be pulled up and off. Service to interior valve parts should be done prior to installing new handle.

b.) SLIDER AND SEAL REMOVAL: Remove #10-32 x 3/16" SOCKET SET SCREWS [14] from VALVE ASSEMBLY [12], using 3/32" Allen wrench. Unscrew front portion of nozzle from valve. SLIDER [17] is pulled out from front of valve. Remove and discard O-RINGS [11, 15 and 16].

2.) VALVE ASSEMBLY SEQUENCE

a.) SLIDER AND SEAL INSTALLATION: Insert O-RINGS [11, 15 and 16] into proper grooves. Lubricate and insert SLIDER [17] into valve, aligning groove with corresponding holes in handle.

b.) HANDLE INSTALLATION: Insert (1) each SPRING [8] and 3/16 DIA. TORLON BALL [6] into lugs in handle, then snap handle into place, with offset holes FORWARD. Carefully align the groove on SLIDER [17] with front offset hole in disc and offset hole in handle. Start SAFETY PIN [7] into offset hole in handle. Push down into engagement with groove in slider, until head of SAFETY PIN [7] is flush with handle. Repeat procedure with CAM PIN [3]. Loctite (2) 5/16-18 x 1/2" BUTTON HEAD SCREWS [4], and insert through lower handle holes. Thread each into corresponding center disc hole. Tighten both 5/16-18 x 1/2" BUTTON HEAD SCREWS [4] securely. Handle should snap firmly and smoothly into all detent positions and SLIDER [17] should move back and forth.

c.) VALVE SHUTOFF ADJUSTMENT: Shutoff sealing of valve is adjusted by the threads between the valve body and the front portion of the nozzle. While holding the VALVE HANDLE [2] against stops in the OFF position, screw front end into valve body until contact with valve plug is felt. Actuate the handle to the ON position then, screw the front end assembly in 1/12 of a turn further to give valve shutoff compression. Replace #10-32 x 3/16" SOCKET SET SCREWS [14].

d.) VALVE ADJUSTMENT FOR SEVERE COLD: To help prevent hose line freezing in cold climates, the valve may be adjusted for intentional leakage by unscrewing the front end slightly. The valve may then be returned to normal adjustment during warm weather as stated above.

E. FRONT END SERVICE PROCEDURE

Tools Required:

Vise with padded jaws

Strap Wrench

3/32" Allen (hex) Wrench

3/16" Allen (hex) Wrench

Loctite #271 Thread Locking Adhesive

Oxyacetylene Torch

Lubricant such as Dow Corning #44 Silicone Grease

TB502 - Shaper Removal Jig

⚠ CAUTION: ATTEMPTING TO DISASSEMBLE BARREL ASSEMBLY [33 OR 36] COULD RESULT IN INJURY. A CONTROL SPRING LOCATED INSIDE THE BARREL ASSEMBLY IS UNDER PRELOAD.

Service to this assembly requires special tooling and training. In the

event that this should need service, please return the complete nozzle to the factory for repairs, or replace the entire barrel assembly.

1.) FRONT END DISASSEMBLY SEQUENCE

a.) SHAPER REMOVAL: The rubber bumper and stream shaper are molded together as a single unit SHAPER WITH BUMPER [54]. The shaper is attached to the SHAPER GUIDE [30] by a threaded joint that is retained by Loctite #271. Grip rear portion of nozzle in vise with padded jaws. Direct a hot narrow flame around the rear portion of the shaper. Heat for approximately 20 seconds, being careful not to damage the bumper or labels (a wet rag wrapped around these areas will help). Use a strap wrench to unscrew the shaper from the shaper guide. Remove the shaper. Inside the shaper are (46) 1/8" DIA. NYLON BALLS [53], some of which will fall free as it is removed. If the shaper is to be reused, clean ball track and replace QUADX-4225 [52]. Service to remaining front end parts must be done before reinstalling shaper.

b.) SHAPER GUIDE REMOVAL: The SHAPER GUIDE [30] may be serviced by removing the (4) 7/32" DIA. TORLON BALLS [32]. The SHAPER GUIDE [30] can then be removed from the BARREL ASSEMBLY [33 or 36]. The balls are intended as a "fuse" to prevent permanent damage to BARREL ASSEMBLY [33 or 36]. In the event of severe impact they will shear off. The pattern control however will remain functional by merely sliding back and forth.

2.) FRONT END ASSEMBLY SEQUENCE

a.) SHAPER GUIDE INSTALLATION: Slide SHAPER GUIDE [30] over BARREL ASSEMBLY [33 or 36]. Insert (4) 7/32" DIA. TORLON BALLS [32].

b.) SHAPER INSTALLATION: Install QUADX-4225 [52] in front groove of SHAPER WITH BUMPER [54]. Grease the seal and ball groove heavily. Place (46) 1/8" NYLON BALLS [53] into greased ballgroove. Apply Loctite #271 to male thread on SHAPER GUIDE [30]. Start shaper onto shaper guide threads, screw down until threads bottom.

F. PROBLEMS

If you have any questions or problems, please feel free to call for assistance — 800-348-2686 • 219-462-6161.



TASK FORCE TIPS
HIGH-PERFORMANCE
FIRE SUPPRESSION EQUIPMENT

2800 East Evans Avenue, Valparaiso, IN 46383
800-348-2686 • 219-462-6161 • Fax 219-464-0620

COUPLINGS

HOSE THREAD COUPLINGS

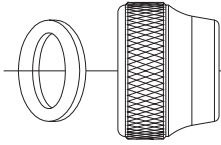

GASKET PART#	COUPLING PART#	THREAD SIZE
V3036	B681*	0.75"
V3040	B680*	1.0"
V3045	B670*	1.25"
V3130	B675*	1.5"

TAPER PIPE COUPLING

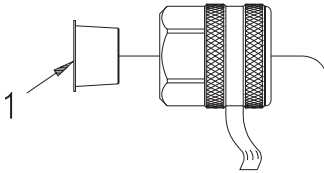

LABEL PART#	COUPLING PART#	THREAD SIZE
B722	B668	1.0" NPT

EXTENDED COUPLING

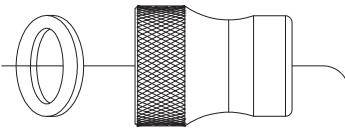

GASKET PART#	COUPLING PART#	THREAD SIZE
V3130	B676B	1.5" BSP

STORZ COUPLINGS

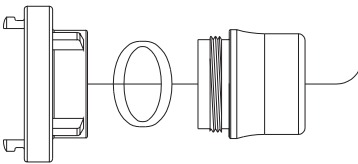

STORZ PART#	STORZ SIZE	O-RING PART#	COUPLING PART#
B686	38 MM	VO-128	B685
H686	55 MM	VO-134	B689
H689	65 MM	VO-143	B688

BRITISH INSTANTANEOUS

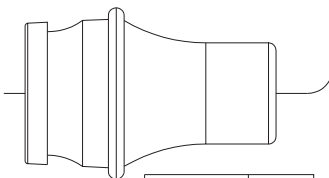

COUPLING PART#	SIZE
B679	1.5"
B687	2.5"

* NOTE: SPECIFY THREAD DESIRED WHEN ORDERING COUPLINGS.

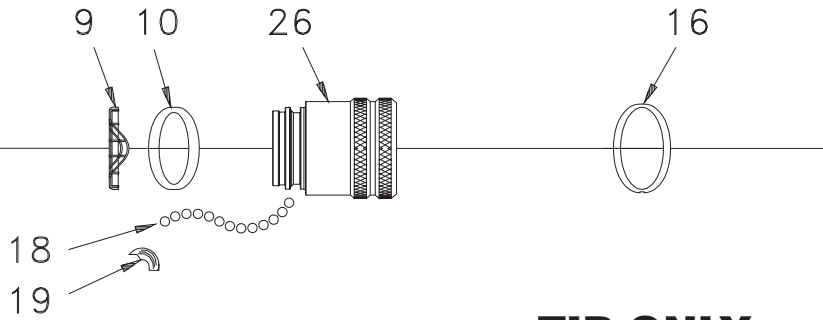

TIP ONLY

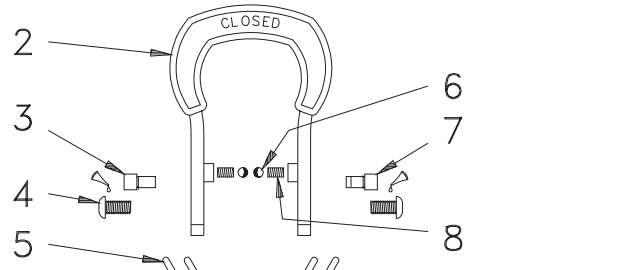

HANDLE

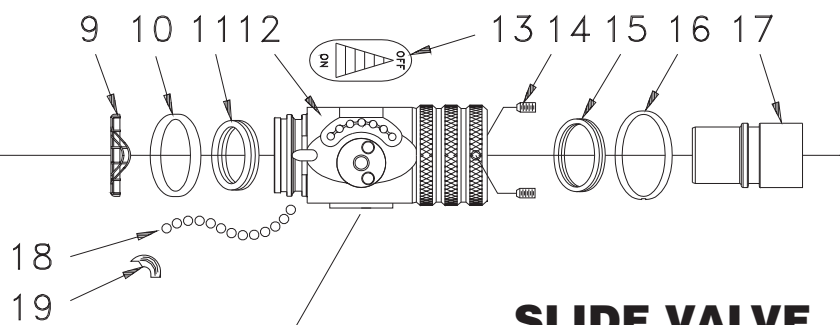

SLIDE VALVE

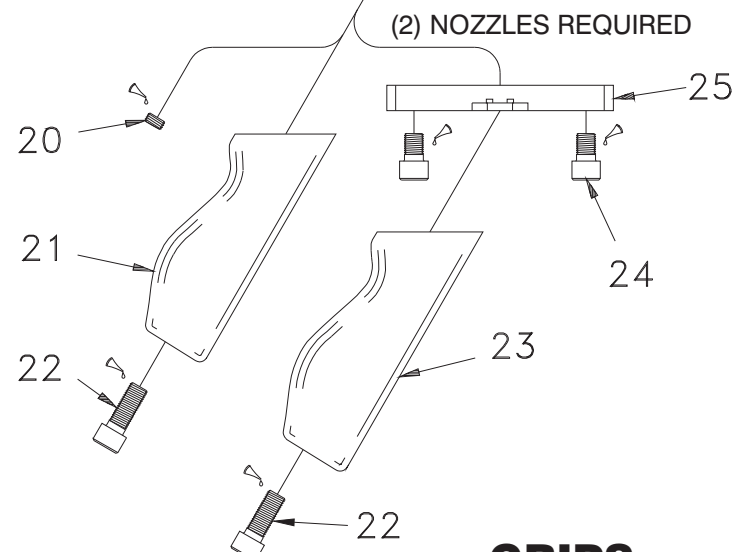

GRIPS

“ULTIMATIC 125”

PARTS LIST & DESCRIPTION



2800 East Evans Avenue
 Valparaiso, IN 46383
 800-348-2686

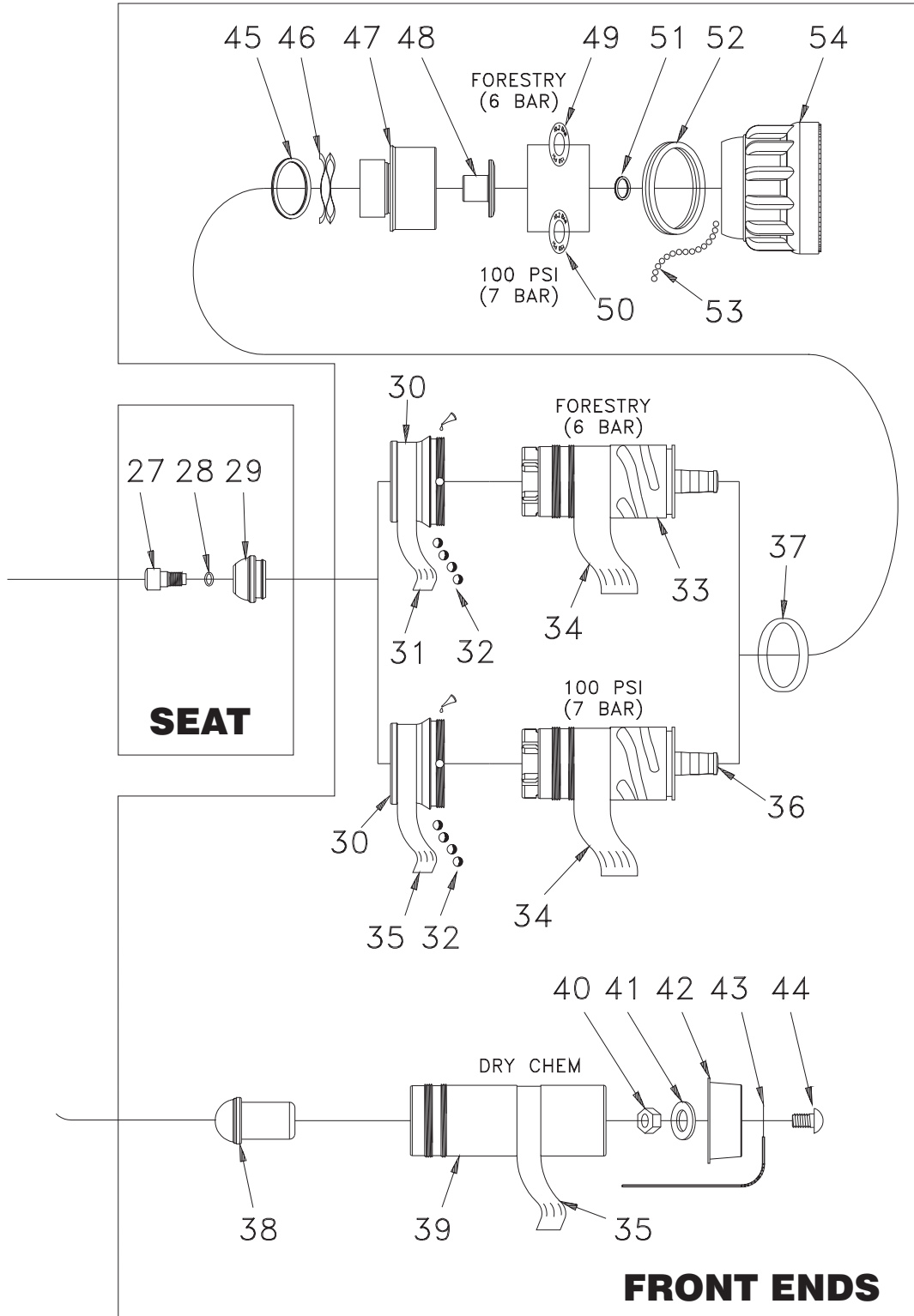

“ULTIMATIC 125” PARTS LIST & DESCRIPTION

REF	DESCRIPTION	QTY	ORDER #
1	Plastic Caplug #14	1	VM1015
2	Valve Handle	1	B620
3	Cam Pin	1	B630
4	5/16-18 x 1/2" Button Head	2	VT31E18BH500
5	Drag Nubs	4	B650
6	3/16" Dia Torlon Ball	2	V2120-Torlon
7	Safety Pin	1	B635
8	Spring # C0180-032-0310-S	2	VM4195
9	1.0" Gasket Grabber	1	B730
10	O-Ring-127	1	VO-127
11	Quadx-4216	1	VOQ-4216
12	Valve Assembly	1	B910
13	Valve Label	1	B750
14	#10-32 x 3/16" Socket Set Screw	2	VT10Y32SS187
15	Quadx-4124	1	VOQ-4124
16	O-Ring-030	1	VO-030
17	Slider	1	B660
18	3/16" Dia Stainless Steel Ball	28	V2120
19	Port Plug	1	B770
20	Swivel Screw	1	X405
21	Pistol Grip	1	HM690
22	3/8-24 x 1.00" SHCS	1	VT37-24SH1.0
23	High Temp Pistol Grip	1	HM691
24	3/8-24 x 1/2 SHCS	1	VT37-24SH500
25	Dual Mounting Plate	1	B695
26	Tip Only Base	1	B665
27	I/O Screw	1	B595
28	O-Ring-109	1	VO-109
29	Valve Plug	1	B590
30	Shaper Guide	1	B510
31	Name Label, Forestry	1	B745F
	Name Label, 6 Bar	1	B745F-F
32	7/32" Dia Torlon Ball	4	V2130-Torlon
33	Barrel Assembly - Forestry (6 Bar)	1	B810
34	Barrel Label	1	B740
35	Name Label, 100 PSI	1	B745
	Name Label, 7 Bar	1	B745-F
36	Barrel Assembly - 100 PSI (7 Bar)	1	B810
37	O-Ring-128	1	VO-128
38	Dry Chem Valve Plug	1	B592
39	Dry Chem Front End	1	B825
40	5/16-18 SS Hex Jam Nut	1	VT31-18NT
41	5/16" SS Washer	1	VW31SS
42	Plastic Caplug #18-X	1	VM1010
43	Cable Assembly	1	VM1020
44	5/16-18 x 1/2" Button Head	1	VT31E18BH500
45	WS-128-F-S02 Smalley Ring	1	V4270
46	Flush Wave Spring	1	B785
47	Barrel Cone Assembly	1	B525
48	Baffle	1	B560
49	Spring Washer, Forestry (6 Bar)	1	B567
50	Spring Washer, 100 PSI (7 Bar)	1	B565
51	WSM-50-S02 Smalley Ring	1	V4280
52	Quadx-4225	1	VOQ-4225
53	1/8" Dia Nylon Ball	46	V2135
54	Shaper with Bumper	1	B500

*** NOTE: Specify thread desired when ordering couplings.**

Barrel Assembly Kit	B810-KIT
Front End Complete	B815
Shaper Repair Kit	B880-KIT
Valve Body Complete w/out Pistol Grip	B915
Handle Repair Kit	B950-KIT
Valve Seal O/H Kit	B960-KIT
Loctite Mini Dispenser	V5010