



MANUAL: LDH VALVED APPLIANCES

INSTRUCTIONS FOR INSTALLATION, SAFE OPERATION AND MAINTENANCE

⚠ WARNING

Understand manual before use. Operation of this device without understanding the manual and receiving proper training is a misuse of this equipment. Obtain safety information at www.tft.com/serial-number

OPERATING RANGE
Pressure Max 300 PSI
Pressure Min Full Vac
Hydrostatic Proof Test: 900 PSI

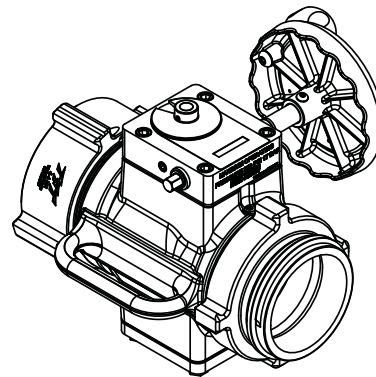
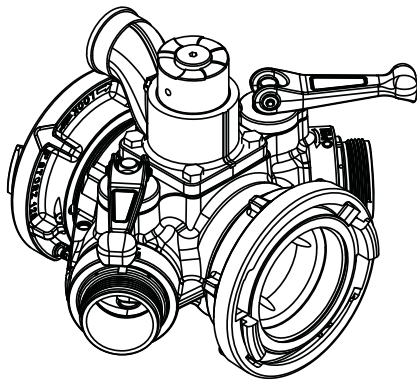
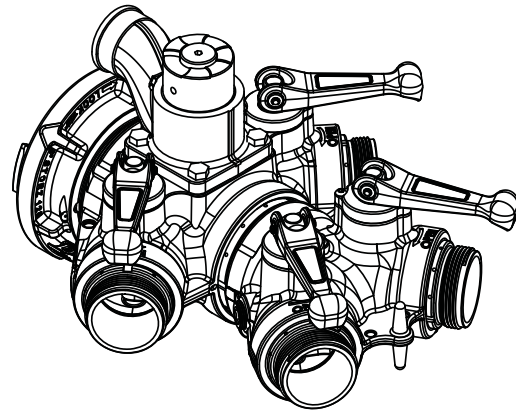
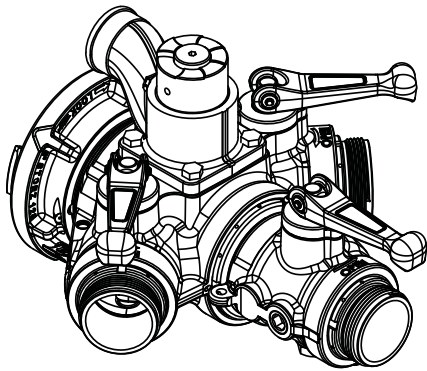

TASK FORCE TIPS, INC.
MADE IN USA • www.tft.com

3701 Innovation Way, Valparaiso, IN 46383-9327 USA
800-348-2686 • 219-462-6161 • Fax 219-464-7155



PERSONAL RESPONSIBILITY CODE

The member companies of FEMSA that provide emergency response equipment and services want responders to know and understand the following:

1. Firefighting and Emergency Response are inherently dangerous activities requiring proper training in their hazards and the use of extreme caution at all times.
2. It is your responsibility to read and understand any user's instructions, including purpose and limitations, provided with any piece of equipment you may be called upon to use.
3. It is your responsibility to know that you have been properly trained in Firefighting and /or Emergency Response and in the use, precautions, and care of any equipment you may be called upon to use.
4. It is your responsibility to be in proper physical condition and to maintain the personal skill level required to operate any equipment you may be called upon to use.
5. It is your responsibility to know that your equipment is in operable condition and has been maintained in accordance with the manufacturer's instructions.
6. Failure to follow these guidelines may result in death, burns or other severe injury.







Fire and Emergency Manufacturers and Service Association
P.O. Box 147, Lynnfield, MA 01940 • www.FEMSA.org

Table Of Contents











- 1.0 MEANING OF SAFETY SIGNAL WORDS
- 2.0 SAFETY
- 3.0 GENERAL INFORMATION
 - 3.1 PARTS IDENTIFICATION AND MODELS
 - 3.2 SPECIFICATIONS
 - 3.3 CORROSION
 - 3.4 USE WITH SALT WATER:
- 4.0 INSTALLATION
 - 4.1 MOUNTING THE APPLIANCE
 - 4.2 CHANGING HANDWHEEL SIDE
 - 4.3 CHANGING OFFSET OF CRANK HANDLE
 - 4.4 STORZ SUCTION GASKET REQUEST
- 5.0 USE
 - 5.1 VALVE OPERATION
 - 5.2 AIR VENT AND WATER DRAIN
 - 5.3 PRESSURE RELIEF VALVE
 - 5.3.1 RELIEF VALVE SETTING PRESSURE
 - 5.4 PRESSURE LOSS
 - 5.5 SUCTION SCREEN
- 6.0 EXPLODED VIEWS & PARTS LISTS
 - 6.1 MANIFOLD VALVE
 - 6.2 IN-LINE VALVE
 - 6.3 3-WAY MANIFOLD VALVE
 - 6.4 4-WAY MANIFOLD VALVE
 - 6.5 2.5" VALVE HANDLE MECHANISM
 - 6.6 STANDARD GEARBOX
 - 6.7 PARALLEL SHAFT GEARBOX
 - 6.8 AIR VENT/DRAIN VALVE
 - 6.9 INLET/OUTLET OPTIONS
 - 6.9.1 COUPLING - MALE HOSE THREADS
 - 6.9.2 COUPLING - FEMALE HOSE THREAD ROCKER LUG
 - 6.9.3 COUPLING - FEMALE HOSE THREADS LONG HANDLE
 - 6.9.4 COUPLING - STORZ
- 7.0 TROUBLESHOOTING
- 8.0 WARRANTY
- 9.0 MAINTENANCE
 - 9.1 SERVICE TESTING
 - 9.1.1 HYDRAULIC TESTING
 - 9.1.2 RELIEF VALVE TESTING
 - 9.1.3 SHUTOFF VALVE TESTING
 - 9.1.4 RECORDS
 - 9.2 CRANKSHAFT OVERRIDE AND REPLACEMENT
 - 9.2.1 CRANKSHAFT OVERRIDE
 - 9.2.2 DIAGNOSIS
 - 9.2.3 CRANKSHAFT REPLACEMENT
- 10.0 REPAIR
- 11.0 ANSWERS TO YOUR QUESTIONS
- 12.0 INSPECTION CHECKLIST

1.0 MEANING OF SAFETY SIGNAL WORDS

A safety related message is identified by a safety alert symbol and a signal word to indicate the level of risk involved with a particular hazard. Per ANSI standard Z535.6-2011, the definitions of the four signal words are as follows:

	DANGER indicates a hazardous situation which, if not avoided, will result in death or serious injury.
	WARNING indicates a hazardous situation which, if not avoided, could result in death or serious injury.
	CAUTION indicates a potentially hazardous situation which, if not avoided, could result in minor or moderate injury.
	NOTICE is used to address practices not related to physical injury.

2.0 SAFETY

	Quick changes in valve position can cause high pressure spikes due to water hammer and may result in damaged equipment which could lead to injury or death. Open and close the valve slowly to avoid water hammer.
	Injury or death can result from burst hoses and fittings. Be sure the pressure relief valve is set at the proper pressure for the type of hose and equipment you are using. See NFPA 1961 and NFPA 1962.
	Injury or death may occur by attempting to use a damaged valve. Per NFPA 1962, the device shall be inspected and tested at least quarterly. Before use, inspect for damage resulting from: <ul style="list-style-type: none">• Failure to drain valve followed by exposure to freezing conditions• Exposure to temperatures in excess of 160 degrees F• Missing parts, physical abuse
	This equipment is intended for use by trained personnel for firefighting. Its use for other purposes may involve hazards not addressed by this manual. Seek appropriate guidance and training to reduce risk of injury.
	Kinks in supply hose may reduce water flow and cause injury or death to persons dependant on water flow. Avoid tight bends to minimize risk of hoseline kinks.
	The appliance may be damaged if frozen while containing significant amounts of water. Such damage may be difficult to detect visually and can lead to possible injury or death. Any time the appliance is subject to possible damage due to freezing, it must be hydrostatically tested by qualified personnel before being considered safe for use.
	Maximum operating pressure 300 psi (20 bar). Do not exceed 300 psi (20 bar) on either side of the valve.
	Valve must be properly connected. Mismatched or damaged connectors may cause leaking or uncoupling under pressure and could cause injury.
	Any alterations to the valve and its markings could diminish safety and constitutes a misuse of this equipment.
	Use with salt water is permissible provided the LDH Valved Appliance is thoroughly cleaned with fresh water after each use. The service life of the LDH Valved Appliance may be shortened due to the effects of corrosion and is not covered under warranty.

3.0 GENERAL INFORMATION

The products in the LDH Suite are lightweight, low friction-loss valves and manifolds that can be used in many water distribution applications. The robust valve mechanism from the TFT Ball Intake Valve is combined with TFT's 2.5" quarter-turn ball valves and folding handles for the ultimate in versatility. Valve seats are field replaceable, and quarter-turn folding valve handles require low force to move, even under pressure. Automatic valve lock on 2.5" valves maintains valve position while flowing at partial openings. Folding handles minimize required storage space. Devices include pipe threaded port for pressure gages. All models include a carrying handle or strap. A polymer bearing ring prevents galvanic corrosion on LDH couplings.

3.1 PARTS IDENTIFICATION AND MODELS

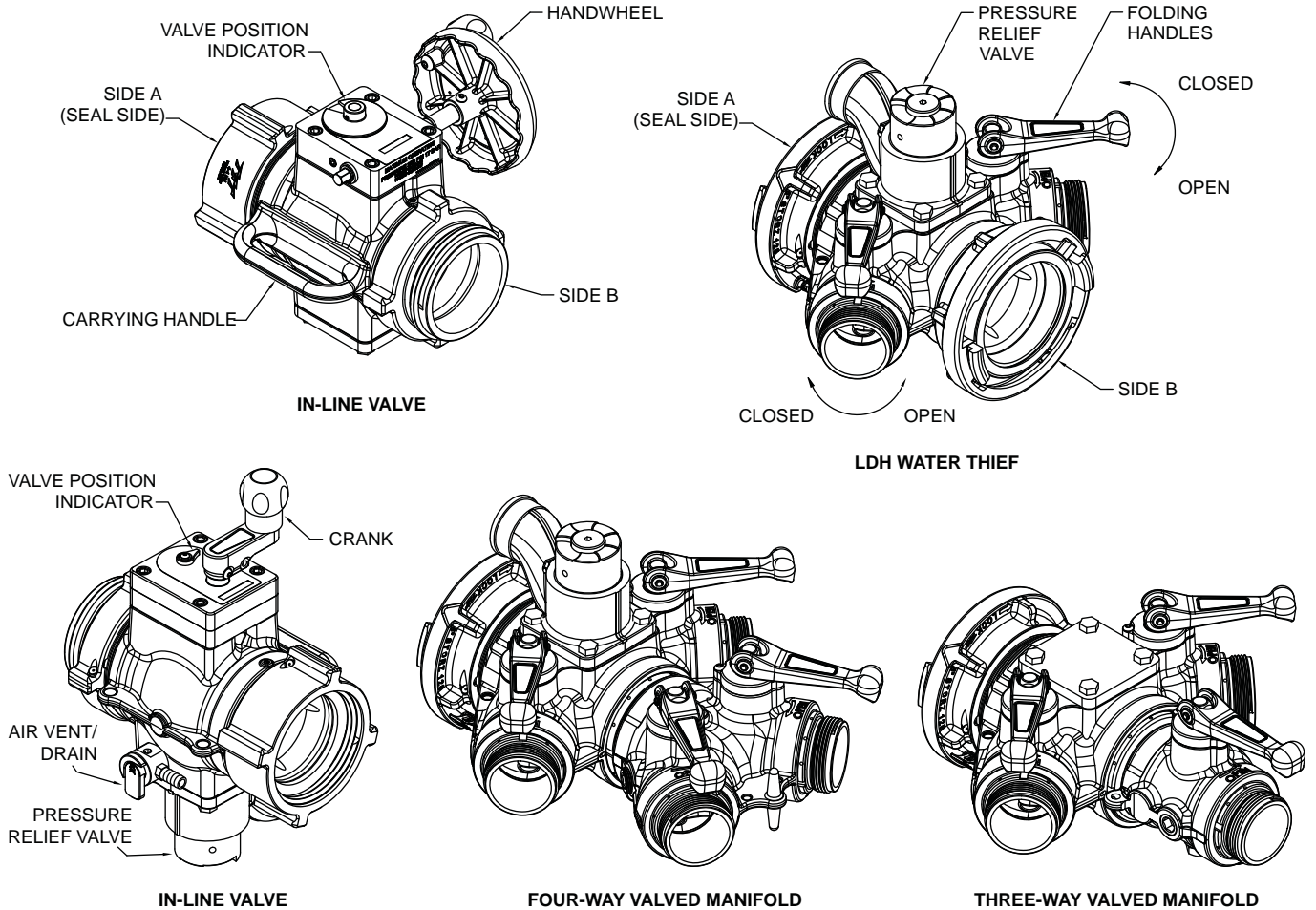

3.2 SPECIFICATIONS

Main LDH Waterway size (at valve seat): 3.65" (93mm)

2.5" Valve waterway size: 2.5" (63.5mm)

LDH Valve meets NFPA 1965 slow close requirement.

Maximum Operating Pressure: 300 psi (20 bar)

Hydrostatic Proof Test Pressure: 900 psi (62 bar)

Temperature Rating*: -25°F to 135°F (-32°C to 57°C)

For temperatures below 32°F (0°C), valves must be drained after use to avoid damage.

See section [2.0 SAFETY](#).

3.3 CORROSION

Aluminum parts are hard anodized. All castings are then powder coated inside and out to help prevent corrosion. Most hose couplings are attached using polymer bearing rings which provide electrical insulation to help prevent galvanic corrosion. The effects of corrosion can be minimized by good maintenance practice. See section [9.0 MAINTENANCE](#).

3.4 USE WITH SALT WATER

Use with salt water is permissible provided valve is thoroughly cleaned with fresh water after each use. The service life of the valve may be shortened due to the effects of corrosion and is not covered under warranty.

4.0 INSTALLATION

4.1 MOUNTING THE APPLIANCE

Make connections to fire hose or fittings on each side of the valved appliance.

CAUTION

Dissimilar metals coupled together can cause galvanic corrosion that can result in the inability to unscrew the threads and complete loss of thread engagement over time. Per NFPA 1962 (2013 edition), if dissimilar metals are left coupled together an anti-corrosive lubricant should be applied to the threads. Also, the coupling should be disconnected and inspected at least quarterly.

4.2 CHANGING HANDWHEEL SIDE

The handwheel can be switched to the opposite side of the gearbox for convenience or if it interferes with other equipment.

To move the handwheel to the opposite side:

1. Remove the retaining ring on the end of the shaft.
2. Pull the shaft out of the gear box.
3. As the shaft is withdrawn, grasp the small key on the shaft so it does not get lost.
4. Remove and switch the two plastic bushings that come out of the sides of the gearbox. The bushing with the large hole is installed on the same side as the handwheel.
5. Apply a small dab of grease to the key and insert it into slot on the shaft.
6. Look through the gear box and note approximate position of the keyway in the worm inside the gearbox. Slide the shaft into the gearbox on the opposite side of the gearbox with the key oriented the same as the keyway. Rotate the shaft until the key finds the keyway and continue to slide the shaft until the hex flats protrude from the small bushing. The retaining groove should be exposed near the hex flats.
7. Reinstall the retaining ring. Do not over expand the retaining ring.

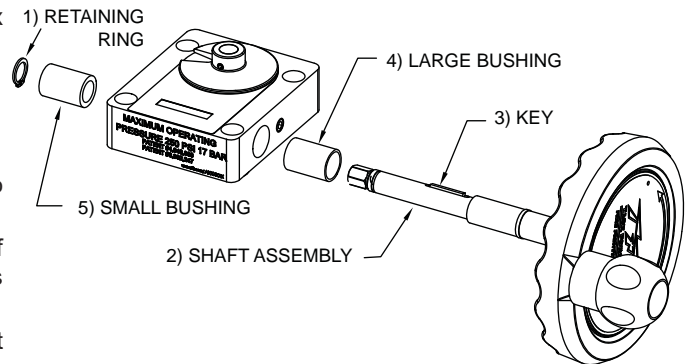

4.3 CHANGING OFFSET OF CRANK HANDLE

When equipped with a crank handle, two offset positions are available to adjust the swing radius of the crank and knob as shown in the figure below. The longer offset position offers reduced effort to operate the valve. The shorter offset is available to avoid interference with other equipment. To change the offset, remove the two 1/4-20 x 1/2" button head cap screws from crank. Place crank in desired position and replace screws.

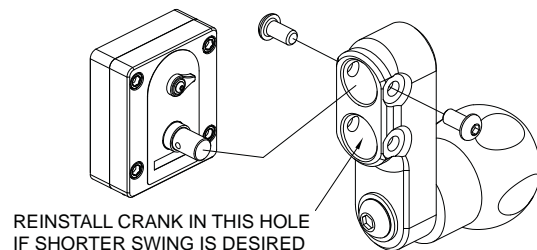

4.4 STORZ SUCTION GASKET REQUEST

If your application of this product requires drafting, you may need a suction gasket.

Please call 1-800-348-2686 to receive a free suction gasket by mail.

Part Numbers: 4" Storz- item #A4216, 5" Storz – item #A4221

5.0 USE

5.1 VALVE OPERATION

The valves covered by this manual utilize positive stops at the OPEN and CLOSED positions. Attempting to close a valve further than the positive stops will not result in a tighter seal between the ball and valve seat. All valves include markings to indicate the direction of handle rotation to open the valve.

Valves with quarter-turn handles will reach the positive stops when the handle is either parallel to the outlet (OPEN position) or perpendicular to the outlet (CLOSED position).

Valves with hand cranks include a valve position indicator. To open the valve, turn the hand crank until the valve position indicator shows OPEN. To close the valve, turn the hand crank the opposite way until the valve position indicator shows CLOSED.

Up to the maximum rated pressure, operating torque should never exceed the values in the table below. If greater torque is required to operate the valve, then that is an indication that the valve needs maintenance. Exceeding 30 ft-lb / 41 N-m torque may damage the appliance. Kicking or standing on the valve controls is considered misuse of the appliance.

Valve Seat Bore Size		Max Acceptable Torque		Max. Acceptable Force		
2.5 in	63.5 mm	20 ft-lb	27 N-m	55 lb	25 kg	1/4-turn Handle
3.65 in	93 mm	12 ft-lb	16 N-m	55 lb	25 kg	Knob

For valves with parallel shaft gearboxes, exceeding 30 ft-lb will result in permanent damage to several components in the gearbox. The damage may not be outwardly obvious, but could result in inability to operate the valve. To restore normal operation, the entire gearbox must be replaced after relieving pressure from the valve.

For valves with worm drive gearboxes, exceeding 45 ft-lb will cause one side of the crank shaft to shear off. This is intentional to prevent further damage to the gearbox. If the shaft shears off, the valve can be operated temporarily using a wrench on the 1/2" hex on the opposite side of the crankshaft. For repair instructions, see section 9.2 CRANKSHAFT OVERRIDE AND REPLACEMENT.

5.2 AIR VENT AND WATER DRAIN



Loss of prime can interrupt water flow and cause injury or death. Always bleed out air with air vent/drain to prevent possible loss of prime.

This device may be equipped with an air vent/drain which will allow the air to escape from the valve when the hose is charged. The air vent/drain is opened by turning the knob counter-clockwise and closed by turning it clockwise.

To drain the water out of the valve after use, open the air vent/drain. A 1/2" Diameter tube may be used to direct the drained water away from the device.

5.3 PRESSURE RELIEF VALVE



Do not leave the pressure relief valve in the OFF position. The pressure relief valve is disabled in the OFF position and offers no protection against over pressurization. The OFF position may be used for controlled pump testing but should not be used for service conditions. Exercise great care to avoid water hammer or other pressure spikes when the pressure relief valve is in the OFF position.



The Pressure Relief Valve may be damaged if frozen while containing significant amounts of water. Such damage may be difficult to detect visually and can lead to possible injury or death. Any time the Pressure Relief Valve is subject to possible damage due to freezing, it must be hydrostatically tested by qualified personnel before being considered safe for use.

LDH valved appliances may be equipped with a pressure relief valve that can be set to any pressure between 90 and 300 psi. Its function is to protect the pump and supply hose from excess pressure. A piece of hose or tubing may be mounted on the round spout to direct water coming out of the relief valve away from the device. The relief valve may be mounted with its opening facing the front, back, right, or left. To change the orientation of the relief valve, remove the four 7/16" bolts on the corners of the relief valve flange, orient the valve in the desired position, and replace the bolts. Use thread-locking compound on the threads of the bolts to prevent them from vibrating loose.

See [LIA-202](#) Pressure Relief Valve Instructions for Safe Operation and Maintenance.

5.3.1 RELIEF VALVE SETTING PRESSURE

To set the relief valve pressure turn the adjusting screw on the relief valve housing until the surface of the screw is even with the desired pressure. A 9/16" (14mm) socket or a 1/4" Allen wrench may be used to turn the adjusting screw. The Pressure relief valve should not be disabled (IE: capped, plugged, or set to the OFF position) for normal service conditions. Disabling the relief valve may result in system damage or hose rupture if the system exceeds operating limits. The pressure relief valve meets the requirements of NFPA 1901.

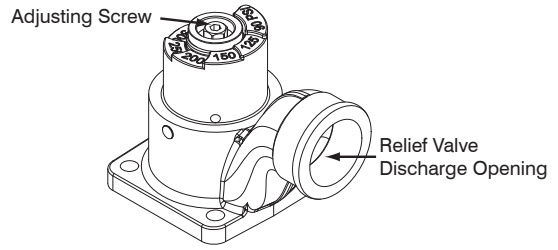

5.4 PRESSURE LOSS

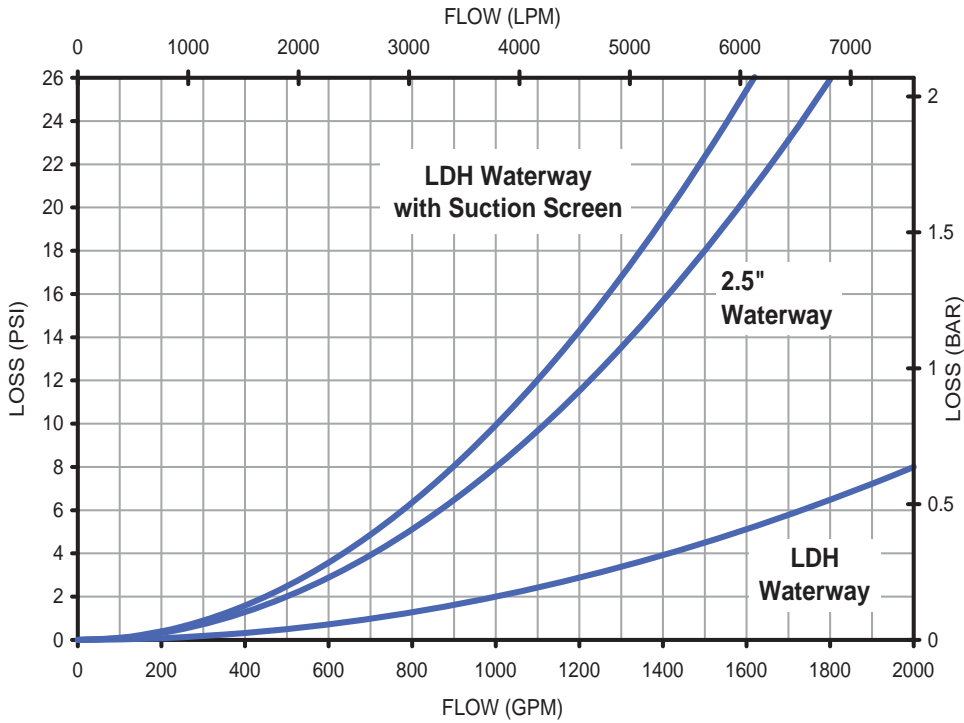

Figure 5.4
Pressure Loss Chart

5.5 SUCTION SCREEN

This device may be equipped with a suction screen to catch debris larger than 3/8" diameter in the waterway. See chart in section 5.4 PRESSURE LOSS to determine additional loss caused by the screen. To add or replace a suction screen, order TFT part # A1410-KIT.

6.0 EXPLODED VIEWS & PARTS LISTS

6.1 MANIFOLD VALVE

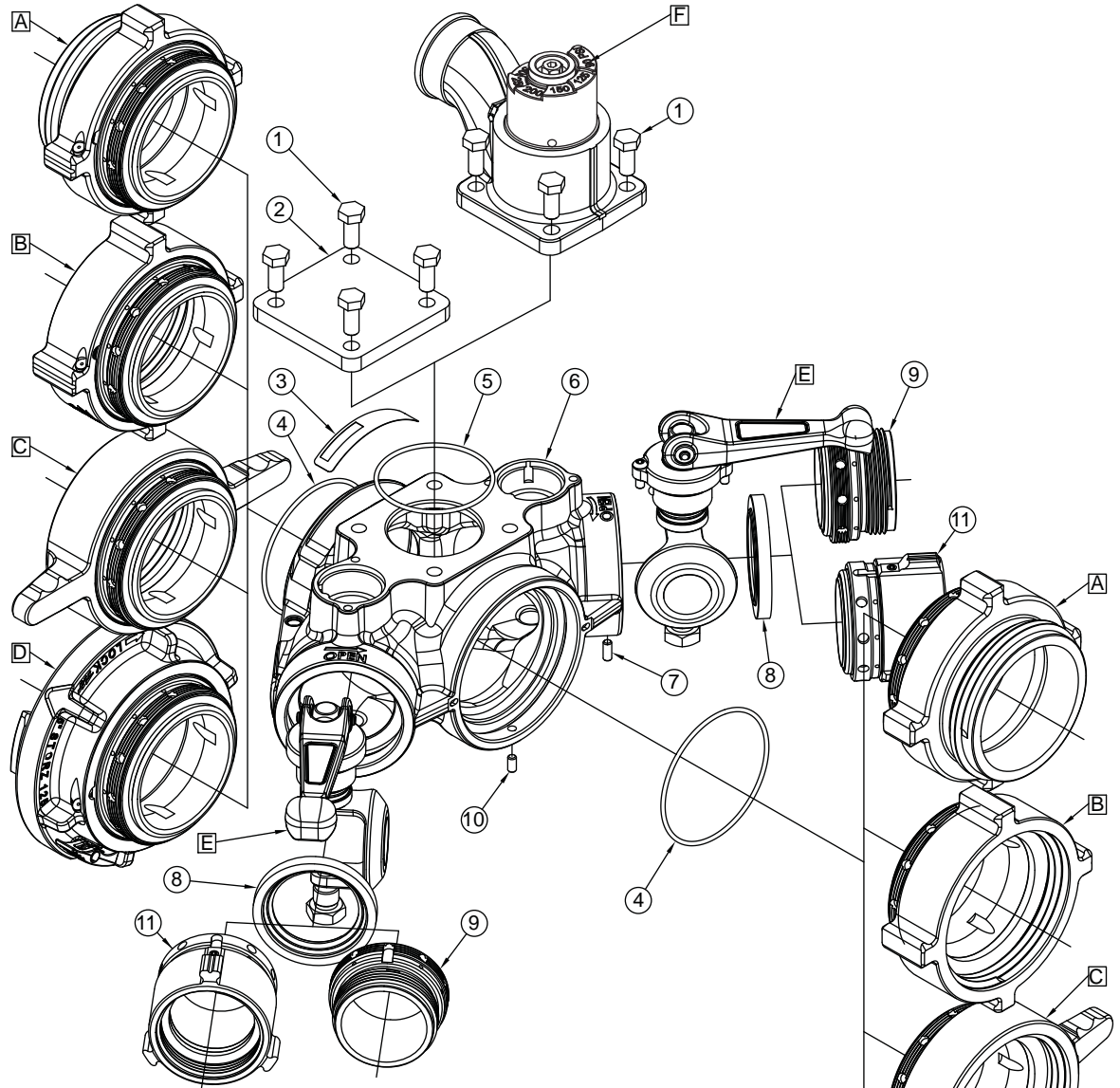

ITEM	DESCRIPTION	QTY	PART #
1	7/16-14 X 1 HEX HEAD BOLT	4	VT43-14HX1.0
2	LDH BLANK CAP	1	X631
3	VALVE LABEL	1	AY305
4	O-RING-243	2	VO-243
5	O-RING-236	1	VO-236
6	MANIFOLD VALVE BODY	1	A2005
7	1/4-20 X 5/8 SET SCREW	2	VT25-20SS625
8	VALVE SEAT	2	AY315
9	SIDE B ADAPTER 2 1/2 NH	2	AY360N
10	1/4-20 X 1/2 SET SCREW	2	VT25-20SS500
11	SIDE B ADAPTER HSBGM30	2	AY365
	COUPLING 2.5"NH	2	P197N
	3/16" SS BALL	96	V2120
	GASKET - 2.5"	2	V3190
	O-RING-151	2	VO-151
	1/4-28 X 1/4 SOCKET SET SCREW	2	VT25-28SS250

ITEM	DESCRIPTION	QTY	PART #
A	COUPLING - MALE HOSE THREADS	-	SEE SECTION 6.10.1
B	COUPLING - FEMALE HOSE THREADS ROCKER LUG	-	SEE SECTION 6.10.2
C	COUPLING - FEMALE HOSE THREADS LONG HANDLE	-	SEE SECTION 6.10.3
D	COUPLING - STORZ	-	SEE SECTION 6.10.4
E	2.5" VALVE HANDLE SUBASSEMBLY	-	SEE SECTION 6.5
F	PRESSURE RELIEF VALVE	-	A1640

6.2 IN-LINE VALVE

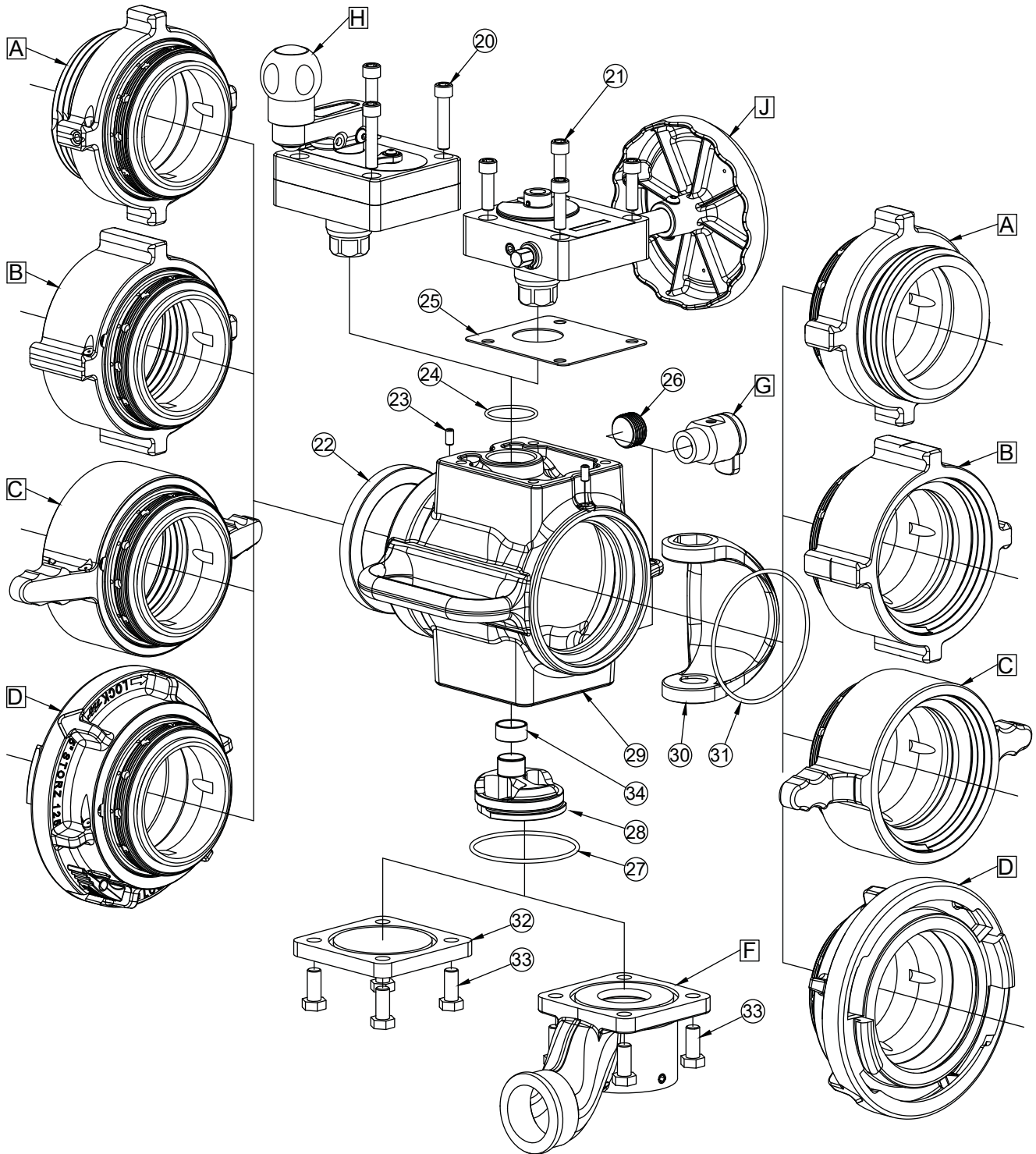

6.2 IN-LINE VALVE PARTS SET

ITEM	DESCRIPTION	QTY	PART #
20	3/8-16 X 1-3/4 SOCKET HEAD SCREW	4	VT37-16SH1.7
21	3/8-16 X 1-1/4 SOCKET HEAD SCREW	4	VT37-16SH1.2
22	VALVE SEAT	1	A1520
23	1/4-20 X 1/2" SET SCREW	2	VT25-20SS500
24	O-RING-128	1	VO-128
25	GEARBOX COVER	1	A1030
26	3/4"NPTM HEX SOCKET PLUG	1	XG410
27	O-RING-236	1	VO-236
28	ALUMINUM TRUNNION	1	A1087A
29	IN-LINE VALVE BODY	1	A2000
30	HALF BALL	1	A1043A
31	O-RING-243	1	VO-243
32	LDH BLANK CAP	1	X631
33	7/16-14 X 1 HEX HEAD BOLT	4	VT43-14HX1.0
34	BUSHING	1	A2094
A	COUPLING - MALE HOSE THREADS	-	SEE SECTION 6.10.1
B	COUPLING - FEMALE HOSE THREADS ROCKER LUG	-	SEE SECTION 6.10.2
C	COUPLING - FEMALE HOSE THREADS LONG HANDLE	-	SEE SECTION 6.10.3
D	COUPLING - STORZ	-	SEE SECTION 6.10.4
F	PRESSURE RELIEF VALVE	-	A1640
G	DRAIN VALVE SUBASSEMBLY	-	SEE SECTION 6.9
H	PARALLEL SHAFT GEARBOX SUBASSEMBLY	-	SEE SECTION 6.7
J	STANDARD GEARBOX SUBASSEMBLY	-	SEE SECTION 6.6

6.3 3-WAY VALVED MANIFOLD

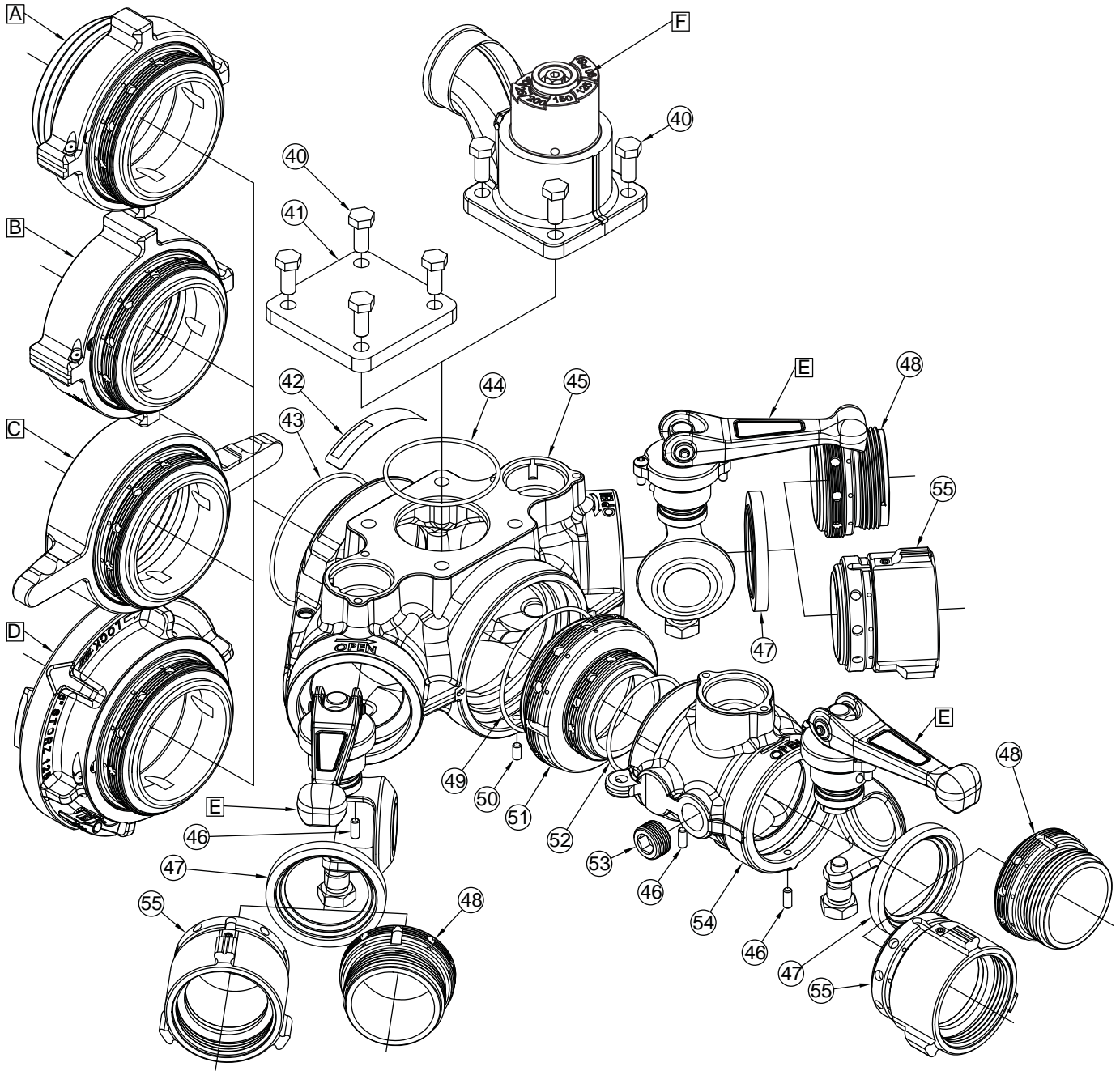

6.3 3-WAY VALVED MANIFOLD PARTS LIST

ITEM	DESCRIPTION	QTY	PART #
40	7/16-14 X 1 HEX HEAD BOLT	4	VT43-14HX1.0
41	LDH BLANK CAP	1	X631
42	VALVE LABEL	1	AY305
43	O-RING-243	1	VO-243
44	O-RING-236	1	VO-236
45	MANIFOLD VALVE BODY	1	A2005
46	1/4-20 X 5/8 SET SCREW	4	VT25-20SS625
47	VALVE SEAT	3	AY315
48	SIDE B ADAPTER 2 1/2 NH	3	AY360N
49	O-RING-241	1	VO-241
50	1/4-20 X 1/2 SET SCREW	2	VT25-20SS500
51	MATE CODE-RRM X 2.5" VALVE	1	A2025
52	O-RING-234	1	VO-234
53	3/4"NPTM HEX SOCKET PLUG	1	XG410
54	2.5" HYDRANT VALVE BODY	1	AY301
55	SIDE B ADAPTER HSBGM30	3	AY365
	COUPLING 2.5"NH	3	P197N
	3/16" SS BALL	144	V2120
	GASKET - 2.5"	3	V3190
	O-RING-151	3	VO-151
	1/4-28 X 1/4 SOCKET SET SCREW	3	VT25-28SS250
A	COUPLING - MALE HOSE THREADS	-	SEE SECTION 6.10.1
B	COUPLING - FEMALE HOSE THREADS ROCKER LUG	-	SEE SECTION 6.10.2
C	COUPLING - FEMALE HOSE THREADS LONG HANDLE	-	SEE SECTION 6.10.3
D	COUPLING - STORZ	-	SEE SECTION 6.10.4
E	2.5" VALVE HANDLE SUBASSEMBLY	-	SEE SECTION 6.5
F	PRESSURE RELIEF VALVE	-	A1640

6.4 4-WAY VALVED MANIFOLD

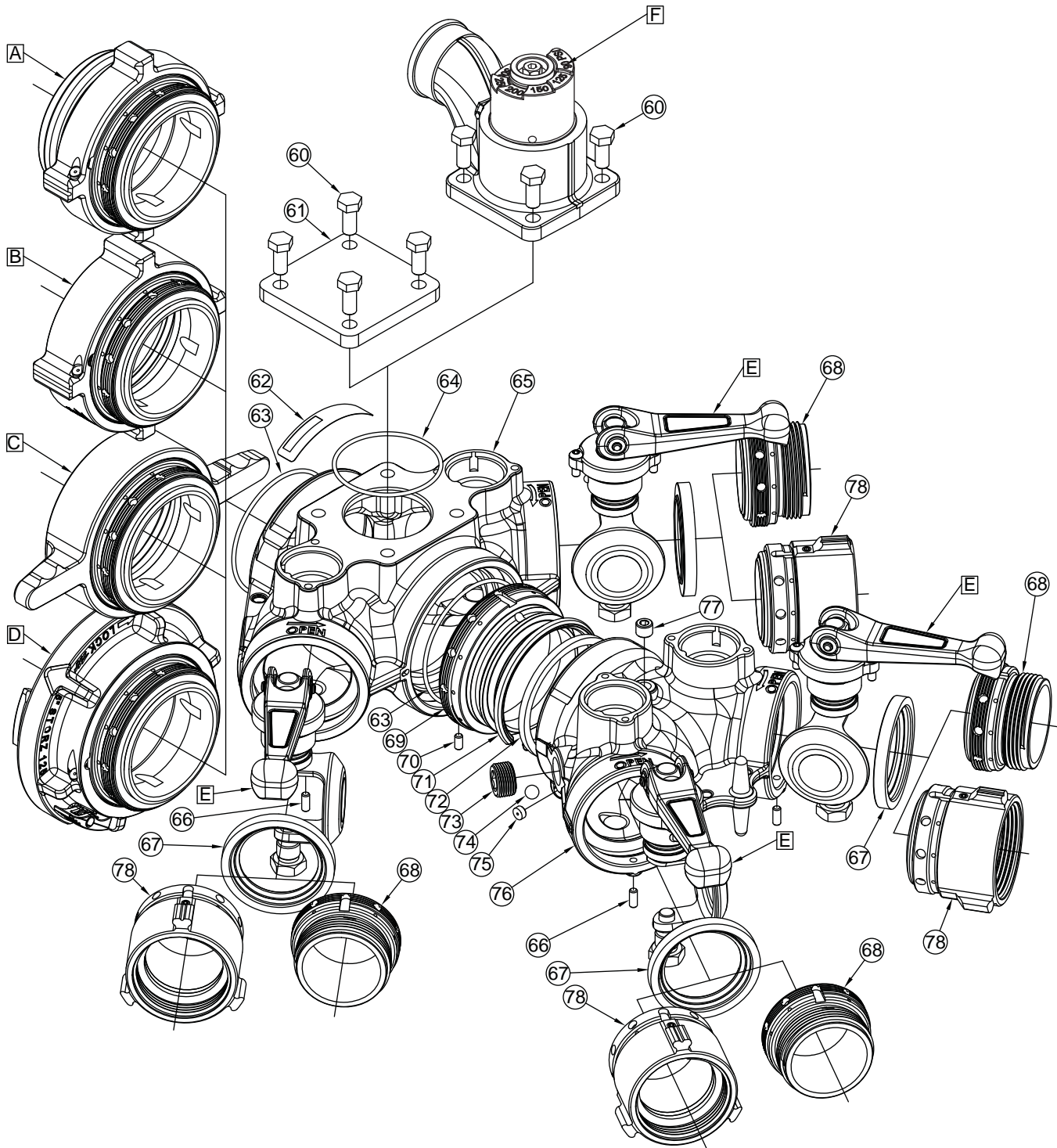

6.4 4-WAY VALVED MANIFOLD PARTS LIST

ITEM	DESCRIPTION	QTY	PART #
60	7/16-14 X 1 HEX HEAD BOLT	4	VT43-14HX1.0
61	LDH BLANK CAP	1	X631
62	VALVE LABEL	1	AY305
63	O-RING-243	2	VO-243
64	O-RING-236	1	VO-236
65	MANIFOLD VALVE BODY	1	A2005
66	1/4-20 X 5/8 SET SCREW	4	VT25-20SS625
67	VALVE SEAT	4	AY315
68	SIDE B ADAPTER 2 1/2 NH	4	AY360N
69	MATE CODE-RRM MODIFIED X PSM4.25	1	A2014
70	1/4-20 X 1/2 SET SCREW	2	VT25-20SS500
71	PLASTIC STRIP 4.25"	1	A1292
72	CUP SEAL LOADED	1	A1597
73	3/4"NPTM HEX SOCKET PLUG	1	XG410
74	7/16" STAINLESS 302 BALL	1	VB437
75	PORT PLUG	1	A1299
76	GATED WYE BODY	1	AY300
77	1/4"NPT PLUG	1	VFSP2M-SS
78	SIDE B ADAPTER HSBGM30	4	AY365
	COUPLING 2.5"NH	4	P197N
	3/16" SS BALL	192	V2120
	GASKET - 2.5"	4	V3190
	O-RING-151	4	VO-151
	1/4-28 X 1/4 SOCKET SET SCREW	4	VT25-28SS250
A	COUPLING - MALE HOSE THREADS	-	SEE SECTION 6.10.1
B	COUPLING - FEMALE HOSE THREADS ROCKER LUG	-	SEE SECTION 6.10.2
C	COUPLING - FEMALE HOSE THREADS LONG HANDLE	-	SEE SECTION 6.10.3
D	COUPLING - STORZ	-	SEE SECTION 6.10.4
E	2.5" VALVE HANDLE SUBASSEMBLY	-	SEE SECTION 6.5
F	PRESSURE RELIEF VALVE	-	A1640

6.5 2.5" VALVE HANDLE MECHANISM

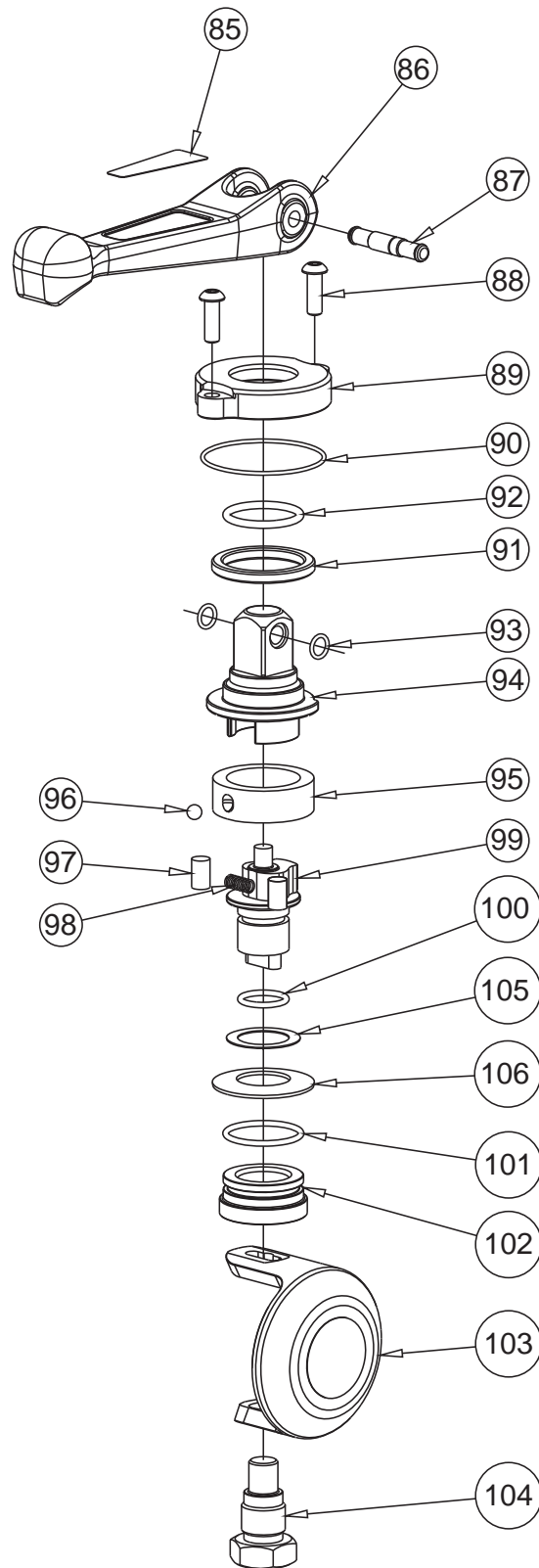

6.5 2.5" VALVE HANDLE MECHANISM PART LIST

ITEM	DESCRIPTION	QTY	PART #
85	HANDLE LABEL - BLUE	1	AY342-BLU
	HANDLE LABEL - RED		AY342-RED
	HANDLE LABEL - WHITE		AY342-WHT
86	VALVE HANDLE	1	AY340
87	HANDLE PIVOT PIN	1	AY345
88	1/4-20 X 3/4 SCREW	2	VT25-20BH750
89	TRUNNION RETAINER	1	AY354
90	O-RING-033	1	VO-033
91	BUSHING	1	AY324
92	O-RING-214	1	VO-234
93	O-RING-011	2	VO-011
94	OUTER UPPER TRUNNION	1	AY320
95	FLOATING RING	1	AY352
96	1/4" SS BALL	1	V2125
97	DOWEL PIN	2	VP312X.50
98	SPRING	1	HC115
99	INNER UPPER TRUNNION	1	AY350
100	O-RING-115	2	VO-115
101	O-RING-123	1	VO-123
102	INNER BUSHING	1	AY351
103	HALF BALL	1	AY310
104	LOWER TRUNNION	1	AY353
	LOWER TRUNNION - LONG EXTENSION		AY355
	LOWER TRUNNION - SHORT EXTENSION		AY356
105	WASHER	1	G636-020
106	BELLEVILLE SPRING	1	AY325

6.6 STANDARD GEARBOX

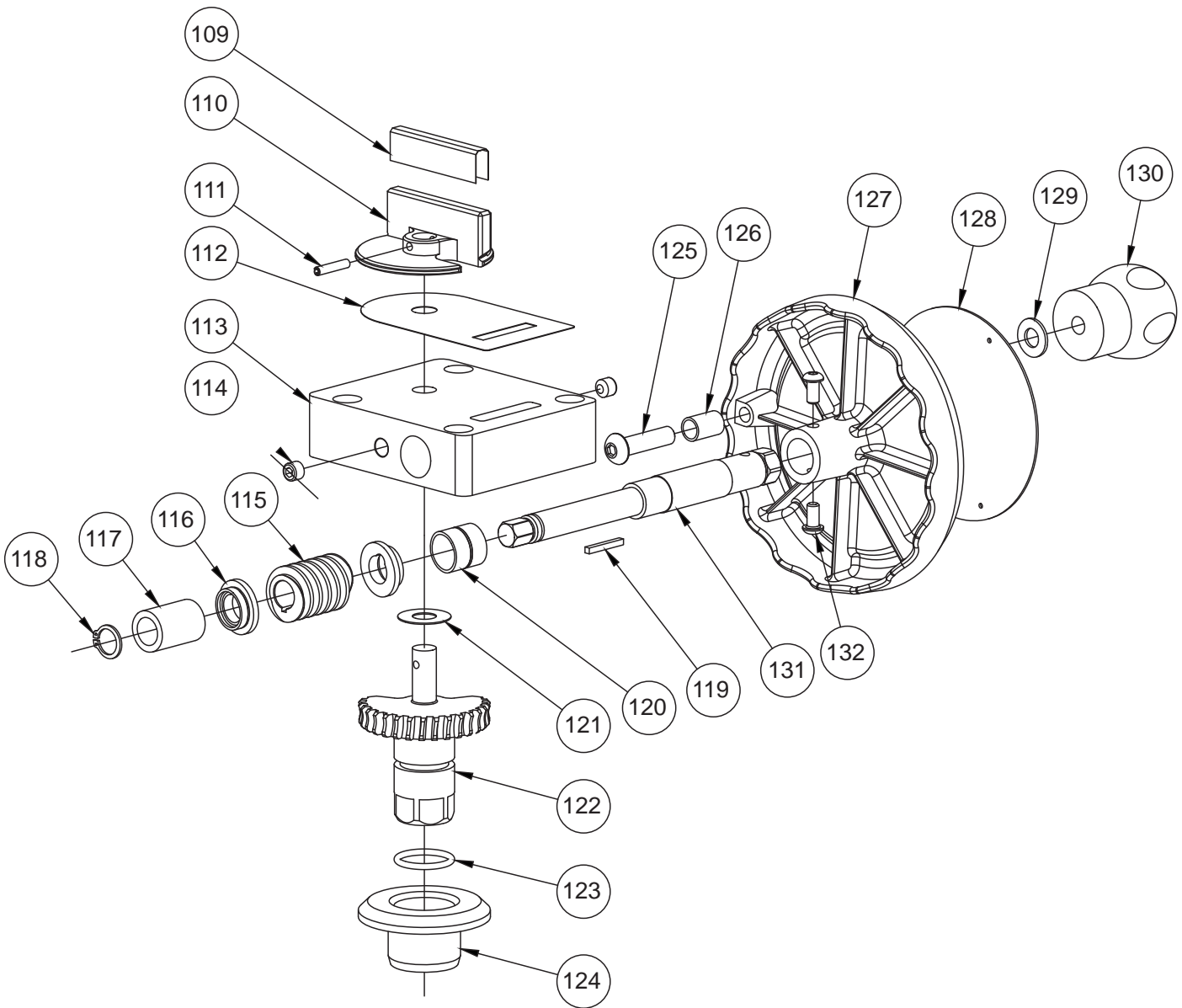

6.6 STANDARD GEARBOX PARTS LIST

ITEM	DESCRIPTION	QTY	PART #
110	POSITION INDICATOR	1	A1517
111	SPIROL PIN	1	V1900
112	LABEL	1	A1301
113	GEARBOX 250PSI	1	A1506
114	3/8-16 X 5/16 SOCKET SET SCREW	1	VT37-16SS312
115	12 DP WORM	1	X220
116	WORM THRUST WASHER	2	A1531
117	THICK BUSHING	1	A1528
118	RETAINING RING 15MM EXTERNAL	1	VR4275
119	KEY	1	X225
120	THIN BUSHING	1	A1527
121	GEAR THRUST WASHER	1	A1502
122	INTEGRAL WORM GEAR & TRUNNION	1	A1501
123	O-RING-214	1	VO-241
124	GEAR SPACER	1	A1511
125	3/8-16 X 1-1/2 BUTTON HEAD SCREW	1	VT37-16BH1.5
126	CRANK BUSHING	1	A1513
127	HANDWHEEL	1	X281
128	HANDWHEEL LABEL	1	A1306
129	WASHER	1	VW812X406-65
130	KNOB	1	A1512
131	CRANK SHAFT	1	A1533
132	1/4-20 X 1/2 BUTTON HEAD SCREW	2	VT25-20BH500

6.7 PARALLEL DRIVE GEARBOX

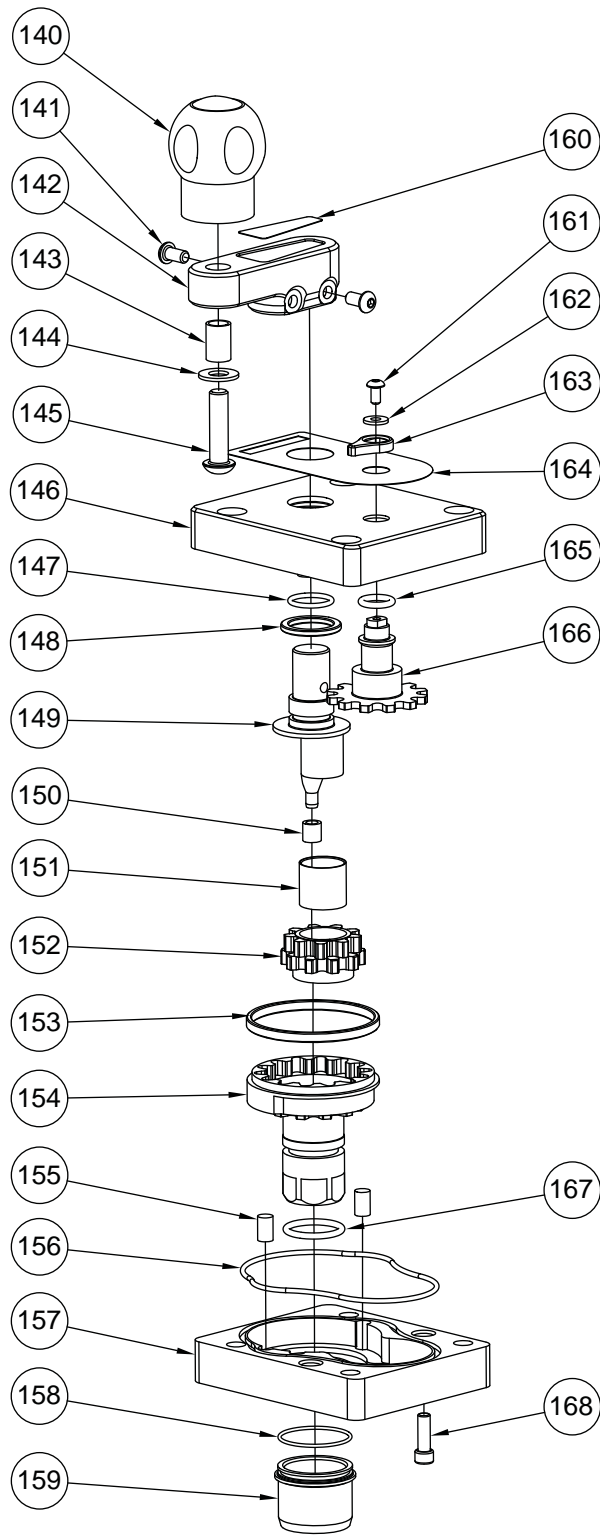

6.7 PARALLEL DRIVE GEARBOX PART LIST

ITEM	DESCRIPTION	QTY	PART #
140	KNOB	1	A1512
141	1/4-20 X 1/2 SCREW	2	VT25-20BH500
142	CRANK	1	A1559
143	CRANK BUSHING	1	A1513
144	WASHER	1	VW812X406-65
145	3/8-16 X 1-1/2 SCREW	1	VT37-16BH1.5
146	GEARBOX	1	A1550
147	O-RING-116	1	VO-116
148	SPACER	1	A1556
149	DRIVE SHAFT	1	A1555
150	NYLON BUSHING	1	AY307
151	GEAR BUSHING	1	A1548
152	DOUBLE GEAR	1	A1554
153	TRUNNION BUSHING	1	A1549
154	INNER TRUNNION	1	A1553
155	DOWEL PIN	2	VP312X.50
156	O-RING-154	1	VO-154
157	SUBPLATE	1	A1551
158	O-RING-028	1	VO-028
159	INNER BUSHING	1	A1552
160	HANDLE LABEL - BLUE	1	AY342-BLU
	HANDLE LABEL - RED		AY342-RED
	HANDLE LABEL - WHITE		AY342-WHT
161	10-24 3/8 SCREW	1	VT10-24BH375
162	WASHER	1	VW500X203-60
163	POSITION INDICATOR	1	A1558
164	LABEL	1	A1550L
165	O-RING 206	1	VO-206
166	INDICATOR GEAR	1	A1557
167	O-RING 214	1	VO-214
168	1/4-20 X 3/4 SCREW	1	VT25-20SH750

6.8 AIR VENT/DRAIN VALVE

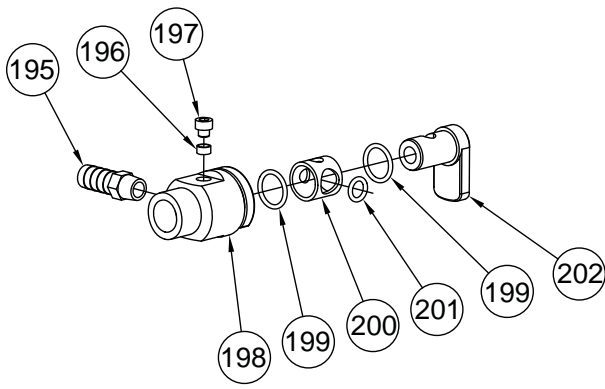

A1621 DRAIN VALVE SUBASSEMBLY			
ITEM	DESCRIPTION	QTY	PART #
195	1/2" BARB X 1/4"NPTM NIPPLE	1	XX329
196	FOLLOWER	1	U251
197	3/8-24 X 3/8 DOG POINT	1	H515
198	DRAIN HOUSING	1	A1543
199	O-RING 115	2	VO-115
200	DRAIN SLEEVE	1	A1541
201	O-RING-110	1	VO-110
202	DRAIN LEVER	1	A1542

6.9 INLET/OUTLET OPTIONS

6.9.1 COUPLING - MALE HOSE THREADS

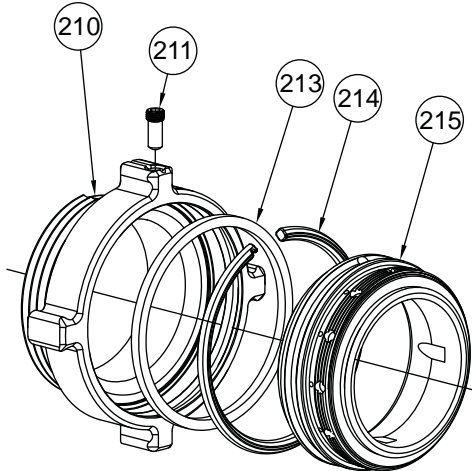

MALE HOSE THREADS				
ITEM	DESCRIPTION	4.0"	4.5"	5.0"
210	SPOUT	A4620N	A4625N	A4630N
211	LOCK-OUT SCREW	A1294	A1294	A1294
213	CUP SEAL LOADED	A1596	A1596	A1596
214	PLASTIC STRIP	A1291	A1291	A1291
215	MATE	A2016	A2016	A2016

6.9.2 COUPLING - FEMALE HOSE THREADS ROCKER LUG

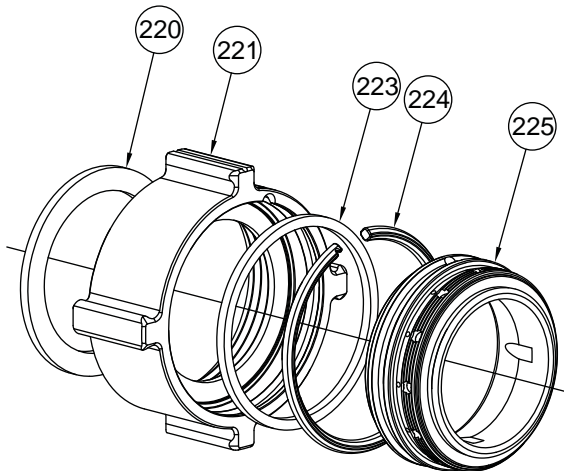

FEMALE HOSE THREADS ROCKER LUGS				
ITEM	DESCRIPTION	4.0"	4.5"	5.0"
220	GASKET	V1398	V3210	V3220
221	COUPLING	A4460N	A4665N	A4670N
223	CUP SEAL	A1596	A1596	A1596
224	PLASTIC STRIP	A1291	A1291	A1291
225	MATE	A2016	A2016	A2016

6.9.3 COUPLING - FEMALE HOSE THREADS LONG HANDLE

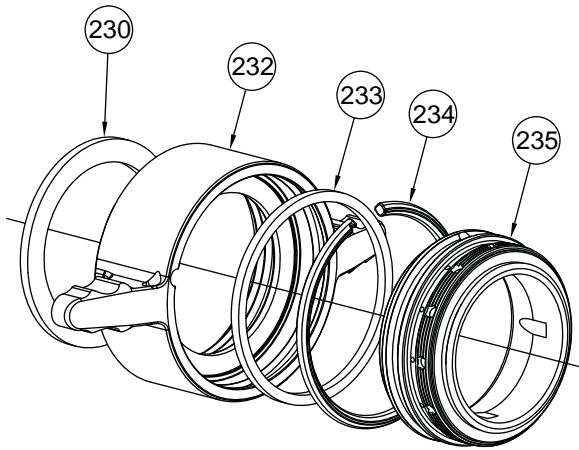

FEMALE HOSE THREADS LONG HANDLES				
ITEM	DESCRIPTION	4.0"	4.5"	5.0"
230	GASKET	V3198	V3210	V3220
232	COUPLING	A4560N	A4565N	A4570N
233	CUP SEAL	A1596	A1596	A1596
234	PLASTIC STRIP	A1291	A1291	A1291
235	MATE	A2016	A2016	A2016

6.9.4 COUPLING - STORZ

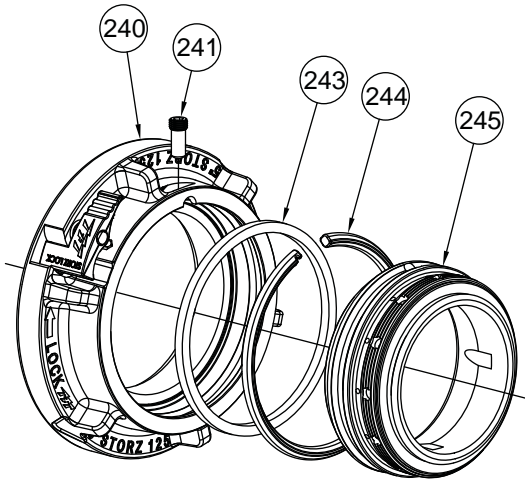

STORZ COUPLING			
ITEM	DESCRIPTION	4.0"	5.0"
240	STORZ SUBASSEMBLY	A4124	A4125
241	LOCK-OUT SCREW	A1294	A1294
243	CUP SEAL LOADED	A1597	A1596
244	PLASTIC STRIP	A1292	A1291
245	MATE	A2015	A2016

7.0 TROUBLESHOOTING

SYMPTOM	POSSIBLE CAUSE	REMEDY
Leaks	Debris or damage in seal area	Clean out debris or replace damaged parts

8.0 WARRANTY

Task Force Tips, Inc., 3701 Innovation Way, Valparaiso, Indiana 46383-9327 USA (“TFT”) warrants to the original purchaser of its LDH Valved Appliances (“equipment”), and to anyone to whom it is transferred, that the equipment shall be free from defects in material and workmanship during the five (5) year period from the date of purchase.

TFT’s obligation under this warranty is specifically limited to replacing or repairing the equipment (or its parts) which are shown by TFT’s examination to be in a defective condition attributable to TFT. To qualify for this limited warranty, the claimant must return the equipment to TFT, at 3701 Innovation Way, Valparaiso, Indiana 46383-9327 USA, within a reasonable time after discovery of the defect. TFT will examine the equipment. If TFT determines that there is a defect attributable to it, TFT will correct the problem within a reasonable time. If the equipment is covered by this limited warranty, TFT will assume the expenses of repair.

If any defect attributable to TFT under this limited warranty cannot be reasonably cured by repair or replacement, TFT may elect to refund the purchase price of the equipment, less reasonable depreciation, in complete discharge of its obligations under this limited warranty. If TFT makes this election, claimant shall return the equipment to TFT free and clear of any liens and encumbrances.

This is a limited warranty. The original purchaser of the equipment, any person to whom it is transferred, and any person who is an intended or unintended beneficiary of the equipment, shall not be entitled to recover from TFT any consequential or incidental damages for injury to person and/or property resulting from any defective equipment manufactured or assembled by TFT. It is agreed and understood that the price stated for the equipment is in part consideration for limiting TFT’s liability. Some states do not allow the exclusion or limitation of incidental or consequential damages, so the above may not apply to you.

TFT shall have no obligation under this limited warranty if the equipment is, or has been, misused or neglected (including failure to provide reasonable maintenance) or if there have been accidents to the equipment or if it has been repaired or altered by someone else.

THIS IS A LIMITED EXPRESS WARRANTY ONLY. TFT EXPRESSLY DISCLAIMS WITH RESPECT TO THE EQUIPMENT ALL IMPLIED WARRANTIES OF MERCHANTABILITY AND ALL IMPLIED WARRANTIES OF FITNESS FOR A PARTICULAR PURPOSE. THERE IS NO WARRANTY OF ANY NATURE MADE BY TFT BEYOND THAT STATED IN THIS DOCUMENT.

This limited warranty gives you specific legal rights, and you may also have other rights which vary from state to state.

9.0 MAINTENANCE

TFT appliances are designed and manufactured to be damage resistant and require minimal maintenance. However, as the primary firefighting tool upon which your life depends, it should be treated accordingly. Do not drop or throw equipment.

This valve should be disconnected, cleaned and visually inspected inside and out at least quarterly for proper function per NFPA 1962 section 8.2, or as water quality and use may require. Moving parts such as handles, valve ball and couplings should be checked for smooth and free operation. Seals shall be greased as needed with a silicone-based grease such as Dow Corning 112. Any scrapes that expose bare aluminum should be cleaned and touched up with enamel paint such as Rust-Oleum. Replace any missing or damaged parts before returning to service. Any repaired device must be tested before being placed in service.

9.1 SERVICE TESTING

In accordance with NFPA 1962 (2013), appliances must be tested a minimum of annually. Appliances failing any part of this test must be removed from service, repaired and retested upon completion of the repair.

9.1.1 HYDRAULIC TEST

1. The appliance being tested shall be positioned in a protective device or cover capable of holding the appliance and tested to a minimum hydrostatic pressure of 300 psi (20.7 bar or 2070 kPa).
2. Test caps capable of withstanding the required hydrostatic pressure shall be attached to openings, and a device capable of exerting the required hydrostatic pressure shall be attached to the appliance.
3. Appliances with relief valves shall have the relief valve outlet blanked off or otherwise closed during the test.
4. All air shall be bled from the system.
5. The gauge pressure shall be increased by 50 psi (3.45 bar or 345 kPa) increments and held for 30 seconds at each pressure up to the maximum pressure for which the appliance is being tested and held for 1 minute without leakage.

9.1.2 RELIEF VALVE TEST

1. Hydrostatic testing of the appliance shall be conducted prior to testing the relief valve.
2. The relief valve shall be tested separately from any device it is connected to.
3. The relief valve shall be set to its lowest setting and pressurized.
4. If the relief valve does not operate at or below a pressure 10 percent over the setting, the test shall be discontinued and the relief valve repaired or replaced.
5. A calibrated test gauge shall be used to verify the setting.
6. After successful completion of the relief valve test, the relief valve shall be reset to the pressure designated by the authority having jurisdiction.
7. The final setting of the relief valve shall be confirmed by pressure testing.

9.1.3 SHUTOFF VALVE TEST

1. If the appliance has a shutoff valve, the intake side of the shutoff valve shall be hydrostatically pressurized to the maximum working pressure of the appliance with the valve in the shutoff position.
2. There shall be no leakage through the valve.
3. A water flow through the fire hose appliance at 100 psi (6.9 bar or 690 kPa) shall be established.
4. The valve shall be closed and reopened twice and shall operate smoothly without evidence of binding or other problems.

9.1.4 RECORDS

A record of testing and repairs must be maintained from the time the appliance is purchased until it is discarded. Each TFT appliance is engraved with a unique serial number which, if so desired, can be used to identify appliance for documentation purposes.

The following information, if applicable, must be included on the test record for each appliance:

1. Assigned identification number
2. Manufacturer
3. Product or model designation
4. Vendor
5. Warranty
6. Hose connection size
7. Maximum operating pressure
8. Flow rate or range
9. Date received and date put in service
10. Date of each service test and service test results
11. Damage and repairs, including who made the repairs and the cost of repair parts
12. Reason removed from service

9.2 CRANKSHAFT OVERRIDE AND REPLACEMENT

The crankshaft includes an intentional shear joint to protect the gear train from overload, costly repairs and loss of service. The magnitude of torque required to shear the crankshaft is several times greater than the torque typically needed to operate the valve at maximum operating pressure. If the crankshaft breaks during use, this is an indication that either there is something obstructing the half ball internally or the crank shaft has been abused (e.g. used as a step for climbing).

9.2.1 CRANKSHAFT OVERRIDE

In an emergency, the opposite side of the crankshaft can be turned using a 1/2" wrench or hex socket. This allows the valve to be open or closed until the crankshaft is replaced. To prevent loss of the 1/8" square key on the crankshaft, do not allow the crankshaft to slide out of gearbox until a replacement crankshaft is acquired. It is important not to rely on this as a long-term method of operation.

9.2.2 DIAGNOSIS

To diagnose the problem that caused the crankshaft to fail, complete the following steps:

1. Close upstream water supply. If possible, relieve pressure leading up to valve.
2. Locate 1/2" hex where crankshaft protrudes from opposite side of gearbox.
3. Gently turn crank shaft away from travel stop using a 1/2" hex wrench. Do not attempt to shock crankshaft free and do not exceed 50 ft-lb (68 Nm) of torque.
4. If crankshaft will not rotate, then half ball is likely obstructed. Only after relieving pressure on flanged joint, unbolt valve. Clear any obstructions and evaluate whether repair is needed before returning to service.
5. If crankshaft is able to rotate, cycle the valve several times from open to closed to determine whether the crankshaft binds at any place between the travel stops. If crankshaft binds, consult Task Force Tips Service Department to determine the appropriate repairs.
6. If crankshaft rotates freely after clearing any obstructions, then a replacement crank shaft may be ordered from Task Force Tips and replaced as described below.

9.2.3 CRANKSHAFT REPLACEMENT

A broken crankshaft can be replaced at any time by completing the following steps, regardless of whether or not the upstream water supply is pressurized. Referring to item numbers shown in section 6.3, follow the steps below:

1. Remove external retaining ring (item 118) adjacent to 1/2" hex on crankshaft. Do not over-expand the retaining ring.
2. Using a punch or Phillips head screwdriver at least 6" in length, gently push on dimple in 1/2" hex end of crankshaft (item 131). Continue to push crankshaft through until it protrudes from opposite side of gearbox.
3. Grab broken end of crankshaft and pull out of gearbox. As crankshaft is withdrawn, grasp small key (item 119) on shaft so it does not get lost.
4. If 1/8" square x 1" long key is not visible in shaft, it has likely fallen into gearbox bore and must be removed before installing new crankshaft. If square key is visible in gearbox bore, slide it out of bore. Needle-nose pliers may be helpful depending on position of key in bore.
5. Verify polymer bushings (item 117 and 120) are still seated in bores on each side of gearbox. If not, locate and replace bushings.
6. Look through gearbox bore and note approximate orientation of square keyway in worm (item 115). Verify round notch in thrust washer (item 116) is aligned with square keyway in worm.
7. Prepare new crankshaft by applying small dab of grease to keyway and seating 1/8" square x 1" long key into keyway. Grease will keep key in place during assembly.
8. Slide shaft into gearbox with key orientation the same as keyway in worm. Rotate shaft slightly in alternating directions until key finds keyway, then push shaft in until it stops. Retaining ring groove and 1/2" hex should be protruding through opposite side of gearbox. If hex is not visible, it may be necessary to slide polymer bushing back into gearbox bore.
9. Install retaining ring (item 118) onto shaft. Do not over-expand the retaining ring.

10.0 REPAIR

Factory service is available with repair time seldom exceeding one day in our facility. Factory serviced appliances are repaired by experienced technicians to original specifications, fully tested and promptly returned. Repair charges for non-warranty items are minimal. Any returns should include a note as to the nature of the problem and whom to reach in case of questions.

Repair parts and service procedures are available for those wishing to perform their own repairs. Task Force Tips assumes no liability for damage to equipment or injury to personnel that is a result of user service. Contact the factory or visit the web site at www.tft.com for parts lists, exploded views, test procedures and troubleshooting guides.

For additional information on care, maintenance and testing, refer to: NFPA 1962: Standard for the Care, Use, Inspection, Service Testing, and Replacement of Fire Hose, Couplings, Nozzles, and Fire Hose Appliances, 2013 Edition

 **Any alterations to the device and its markings could diminish safety and constitutes a misuse of this product.**

11.0 ANSWERS TO YOUR QUESTIONS

We appreciate the opportunity of serving you and making your job easier. If you have any problems or questions, our toll-free "Hydraulics Hotline", 800-348-2686, is normally available to you 24 hours a day, 7 days a week.

12.0 INSPECTION CHECKLIST

BEFORE EACH USE,

- Fire hoses must be securely attached to appliances.
- Appliances must also be inspected to the following checklist.

BEFORE BEING PLACED BACK IN SERVICE,

1. All valves open and close smoothly and fully.
2. The waterway is clear of obstructions.
3. There is no damage to any thread or other type connection.
4. The pressure setting of the relief valve, if any, is set correctly.
5. All locks and hold-down devices work properly.
6. Internal gaskets are in accordance with NFPA 1962 (2013) Section 7.2.
7. There is no damage to the appliance (e.g., dents, cracks, corrosion, or other defects that could impair operation).
8. All swiveling connections rotate freely.
9. There are no missing parts or components.
10. The marking for maximum operating pressure is visible.
11. There are no missing, broken, or worn lugs on couplings.

NFPA 1962: Standard for the care, use, inspection, service testing, and replacement of fire hose, couplings, nozzles and fire hose appliances. (2013 ed., Section 6.2.1). Quincy, MA: National Fire Protection Agency.

 **Any appliance failing any part of the inspection checklist is unsafe and must have the problem corrected before use. Operating an appliance that fails any of the above inspections is a misuse of this equipment.**