

INSTRUCTIONS FOR INSTALLATION, SAFE OPERATION AND MAINTENANCE

⚠ WARNING

Read instruction manual before use. Operation of this device without understanding the manual and receiving proper training can be dangerous and is a misuse of this equipment. Call 800-348-2686 with any questions.

⚠ WARNING

This instruction manual is intended to familiarize firefighters and maintenance personnel with the operation, servicing and safety procedures associated with the Large Diameter Hose Valved Appliances.

⚠ WARNING

This manual should be kept available to all operating and maintenance personnel.

OPERATING RANGE
Pressure Max 300 PSI
Pressure Min Full Vac
Hydrostatic Proof Test: 900 PSI

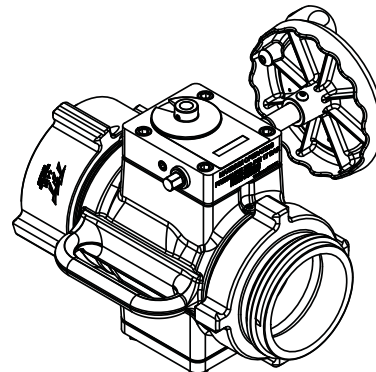
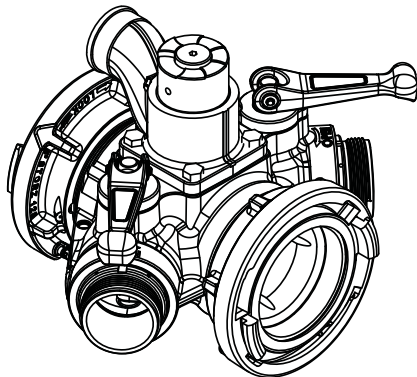
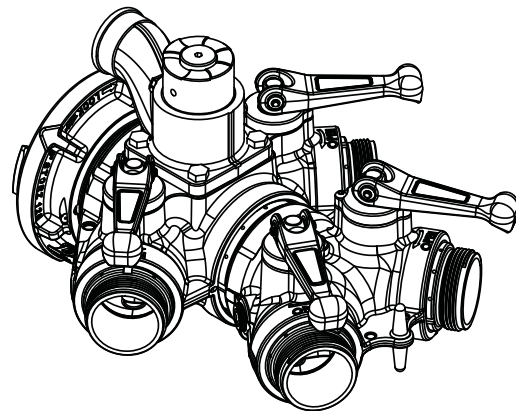
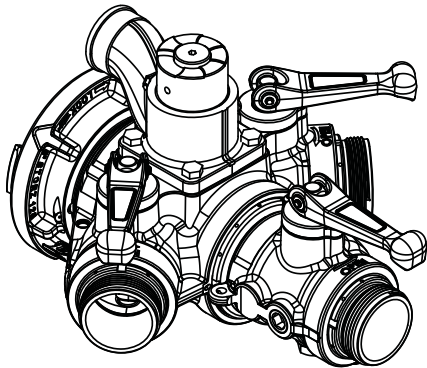



Table Of Contents

1.0 MEANING OF SAFETY SIGNAL WORDS	7.0 EXPLODED VIEWS & PARTS LISTS
2.0 SAFETY	7.1 MANIFOLD VALVE
3.0 GENERAL INFORMATION	7.2 IN-LINE VALVE
3.1 PARTS IDENTIFICATION AND MODELS	7.3 3-WAY MANIFOLD VALVE
3.2 SPECIFICATIONS	7.4 4-WAY MANIFOLD VALVE
3.3 CORROSION	7.5 2.5" VALVE HANDLE MECHANISM
3.4 USE WITH SALT WATER:	7.6 STANDARD GEARBOX
4.0 INSTALLATION	7.7 PARALLEL SHAFT GEARBOX
4.1 CHANGING HANDWHEEL SIDE	7.8 PRESSURE RELIEF VALVE
4.2 CHANGING OFFSET OF CRANK HANDLE	7.9 AIR VENT/DRAIN VALVE
4.3 STORZ SUCTION GASKET REQUEST	7.10 INLET/OUTLET OPTIONS
5.0 USE	7.10.1 COUPLING - MALE HOSE THREADS
5.1 VALVE POSITION INDICATOR	7.10.2 COUPLING - FEMALE HOSE THREAD ROCKER LUG
5.2 AIR VENT AND WATER DRAIN	7.10.3 COUPLING - FEMALE HOSE THREADS LONG HANDLE
5.3 PRESSURE RELIEF VALVE	7.10.4 COUPLING - STORZ
5.4 SUCTION SCREEN	8.0 ANSWERS TO YOUR QUESTIONS
5.5 PRESSURE LOSS	9.0 WARRANTY
6.0 MAINTENANCE	



DANGER

PERSONAL RESPONSIBILITY CODE

The member companies of FEMSA that provide emergency response equipment and services want responders to know and understand the following:

1. Firefighting and Emergency Response are inherently dangerous activities requiring proper training in their hazards and the use of extreme caution at all times.
2. It is your responsibility to read and understand any user's instructions, including purpose and limitations, provided with any piece of equipment you may be called upon to use.
3. It is your responsibility to know that you have been properly trained in Firefighting and /or Emergency Response and in the use, precautions, and care of any equipment you may be called upon to use.
4. It is your responsibility to be in proper physical condition and to maintain the personal skill level required to operate any equipment you may be called upon to use.
5. It is your responsibility to know that your equipment is in operable condition and has been maintained in accordance with the manufacturer's instructions.
6. Failure to follow these guidelines may result in death, burns or other severe injury.



Fire and Emergency Manufacturers and Service Association
P.O. Box 147, Lynnfield, MA 01940 • www.FEMSA.org

1.0 MEANING OF SAFETY SIGNAL WORDS

A safety related message is identified by a safety alert symbol and a signal word to indicate the level of risk involved with a particular hazard. Per ANSI standard Z535.6-2006, the definitions of the four signal words are as follows:



DANGER indicates a hazardous situation which, if not avoided, will result in death or serious injury.



WARNING indicates a hazardous situation which, if not avoided, could result in death or serious injury.



CAUTION indicates a potentially hazardous situation which, if not avoided, may result in minor or moderate injury.



NOTICE is used to address practices not related to personal injury.

2.0 SAFETY



Quick changes in valve position can cause high pressure spikes due to water hammer and may result in damaged equipment which could lead to injury or death. Open and close the valve slowly to avoid water hammer.



The Pressure Relief Valve will open to relieve excess pressure but it may not have enough flow capacity to protect against large pressure spikes such as those caused by water hammer. Excess pressure can cause equipment failure and directly or indirectly lead to injury or death. Always operate valves slowly to avoid the risk of water hammer.



Injury or death can result from burst hoses and fittings. Be sure the pressure relief valve is set at the proper pressure for the type of hose and equipment you are using. See NFPA 1961 and NFPA 1962.



Injury or death may occur by attempting to use a damaged valve. Per NFPA 1962, the device shall be inspected and tested at least quarterly. Before use, inspect for damage resulting from:

- Failure to drain valve followed by exposure to freezing conditions
- Exposure to temperatures in excess of 160 degrees F
- Missing parts, physical abuse



This equipment is intended for use by trained personnel for firefighting. Its use for other purposes may involve hazards not addressed by this manual. Seek appropriate guidance and training to reduce risk of injury.



Kinks in supply hose may reduce water flow and cause injury or death to persons dependant on water flow. Avoid tight bends to minimize risk of hoseline kinks.



The valve may be damaged if frozen while containing significant amounts of water. Such damage may be difficult to detect visually and can lead to possible injury or death. Any time the valve is subject to possible damage due to freezing, it must be hydrostatically tested by qualified personnel before being considered safe for use.



Maximum operating pressure 300 psi (20 bar). Do not exceed 300 psi (20 bar) on either side of the valve.



Valve must be properly connected. Mismatched or damaged connectors may cause leaking or uncoupling under pressure and could cause injury.

3.0 GENERAL INFORMATION

The products in the LDH Suite are lightweight, low friction-loss valves and manifolds that can be used in many water distribution applications. The robust valve mechanism from the TFT Ball Intake Valve is combined with TFT's 2.5" quarter-turn ball valves and folding handles for the ultimate in versatility. Valve seats are field replaceable, and quarter-turn folding valve handles require low force to move, even under pressure. Automatic valve lock on 2.5" valves maintains valve position while flowing at partial openings. Folding handles minimize required storage space. Devices include pipe threaded port for pressure gages. All models include a carrying handle or strap. A polymer bearing ring prevents galvanic corrosion on LDH couplings.

3.1 PARTS IDENTIFICATION AND MODELS

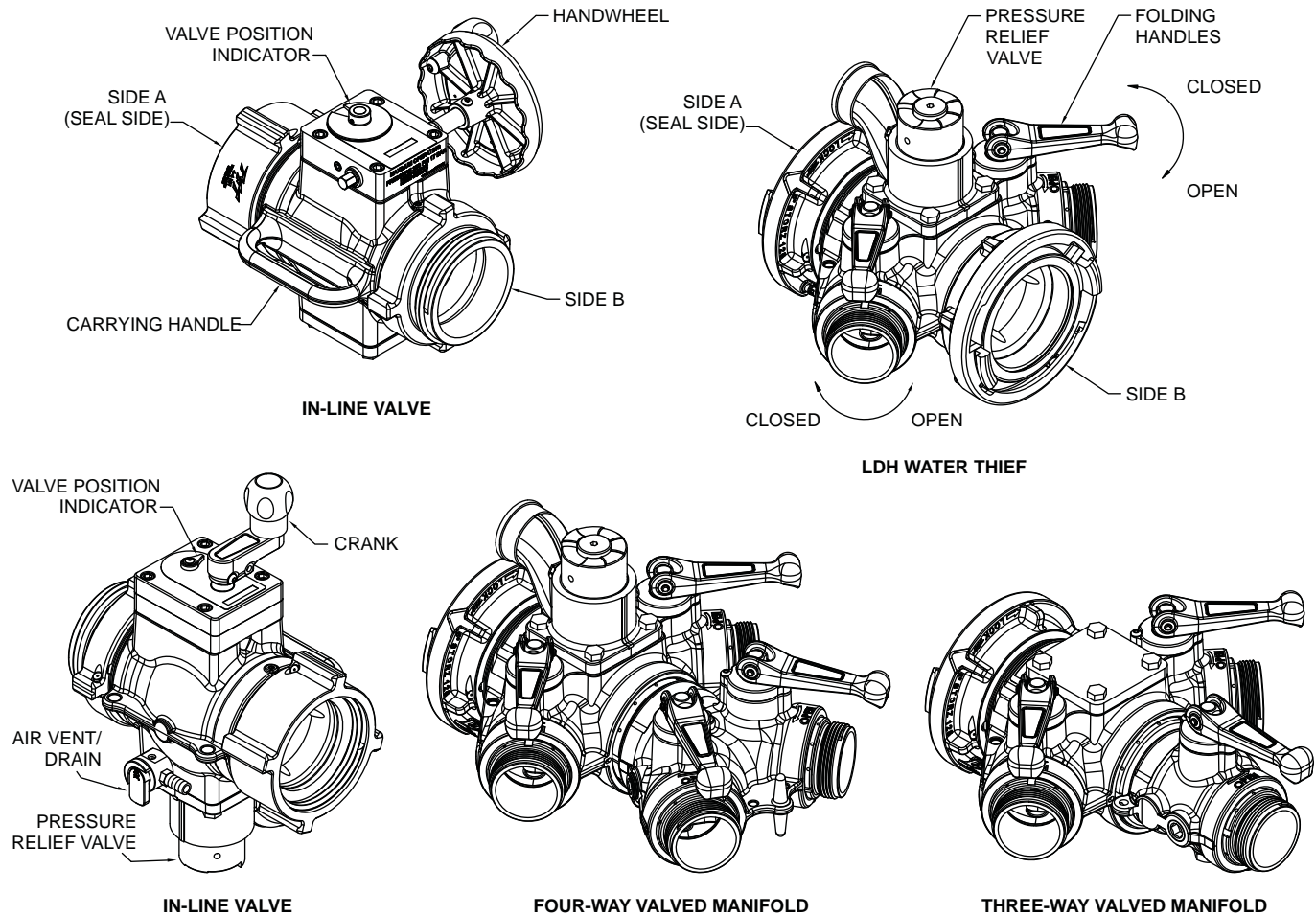

3.2 SPECIFICATIONS

Main LDH Waterway size (at valve seat): 3.65" (93mm)

2.5" Valve waterway size: 2.5" (63.5mm)

LDH Valve meets NFPA 1965 slow close requirement.

Maximum Operating Pressure: 300 psi (20 bar)

Hydrostatic Proof Test Pressure: 900 psi (62 bar)

Temperature Rating*: -25°F to 135°F (-32°C to 57°C)

For temperatures below 32°F (0°C), valves must be drained after use to avoid damage.

See section **2.0 SAFETY**.

3.3 CORROSION

Most hose couplings are attached using polymer bearing rings which provide electrical insulation to help galvanic corrosion. The parts are hard anodized, and powder coated inside and out to help prevent corrosion. The effects of corrosion can be minimized by good maintenance practice.

See section **3.5 MAINTENANCE**.

3.4 USE WITH SALT WATER

Use with salt water is permissible provided valve is thoroughly cleaned with fresh water after each use. The service life of the valve may be shortened due to the effects of corrosion and is not covered under warranty.

4.0 INSTALLATION

4.1 CHANGING HANDWHEEL SIDE

The handwheel can be switched to the opposite side of the gearbox for convenience or if it interferes with other equipment. To move the handwheel to the opposite side:

1. Remove the retaining ring on the end of the shaft.
2. Pull the shaft out of the gear box.
3. As the shaft is withdrawn, grasp the small key on the shaft so it does not get lost.
4. Remove and switch the two plastic bushings that come out of the sides of the gearbox. The bushing with the large hole is installed on the same side as the handwheel.
5. Apply a small dab of grease to the key and insert it into slot on the shaft.
6. Look through the gear box and note approximate position of the keyway in the worm inside the gearbox. Slide the shaft into the gearbox on the opposite side of the gearbox with the key oriented the same as the keyway. Rotate the shaft until the key finds the keyway and continue to slide the shaft until the hex flats protrude from the small bushing. The retaining groove should be exposed near the hex flats.
7. Reinstall the retaining ring. Do not over expand the retaining ring.

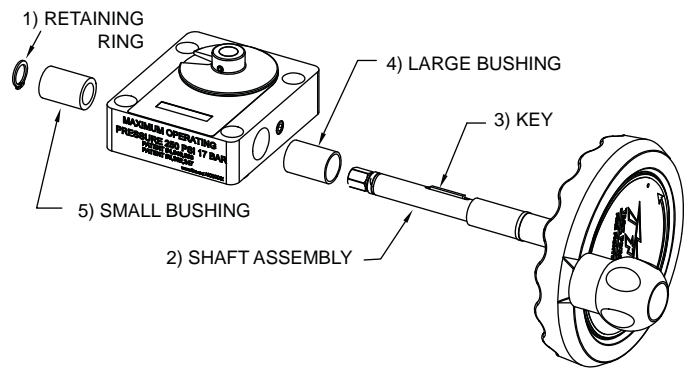

4.2 CHANGING OFFSET OF CRANK HANDLE

When equipped with a crank handle, two offset positions are available to adjust the swing radius of the crank and knob as shown in the figure below. The longer offset position offers reduced effort to operate the valve. The shorter offset is available to avoid interference with other equipment. To change the offset, remove the two 1/4-20 x 1/2" button head cap screws from crank. Place crank in desired position and replace screws.

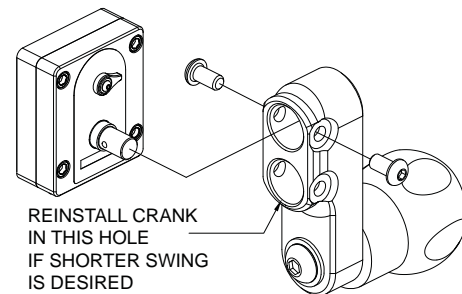

4.3 STORZ SUCTION GASKET REQUEST

If your application of this product requires drafting, you may need a suction gasket.

Please call 1-800-348-2686 to receive a free suction gasket by mail.

Part Numbers: 4" Storz- item #A4216, 5" Storz – item #A4221

5.0 USE

5.1 VALVE POSITION INDICATOR

To open the valve turn the handwheel or crank until the valve position indicator says "OPEN". To close the valve turn the valve handwheel or crank the opposite way until the valve position indicator says "CLOSED".

5.2 AIR VENT AND WATER DRAIN

This device may be equipped with an air vent/drain which will allow the air to escape from the valve when the hose is charged. The air vent/drain is opened by turning the knob counter-clockwise and closed by turning it clockwise.

To drain the water out of the valve after use, open the air vent/drain. A 1/2" diameter tube may be used to direct the drained water away from the device.

▲ DANGER

Loss of prime can interrupt water flow and cause injury or death. Always bleed out air with air vent/drain to prevent possible loss of prime.

5.3 PRESSURE RELIEF VALVE

LDH valved appliances may be equipped with a pressure relief valve that can be set to any pressure between 50 and 200 psi. Its function is to protect the pump and supply hose from excess pressure. A piece of hose or tubing may be mounted on the round spout to direct water coming out of the relief valve away from the device. The relief valve may be mounted with its opening facing the front, back, right, or left. To change the orientation of the relief valve, remove the four 7/16" bolts on the corners of the relief valve flange, orient the valve in the desired position, and replace the bolts. Use thread-locking compound on the threads of the bolts to prevent them from vibrating loose.

See [LIA-202](#) Pressure Relief Valve Instructions for Safe Operation and Maintenance.

5.4 SUCTION SCREEN

This device may be equipped with a suction screen to catch debris larger than 3/8" diameter in the waterway. See chart in section 5.7 PRESSURE LOSS to determine additional loss caused by the screen. To add or replace a suction screen, order TFT part # A1410-KIT.

5.5 PRESSURE LOSS

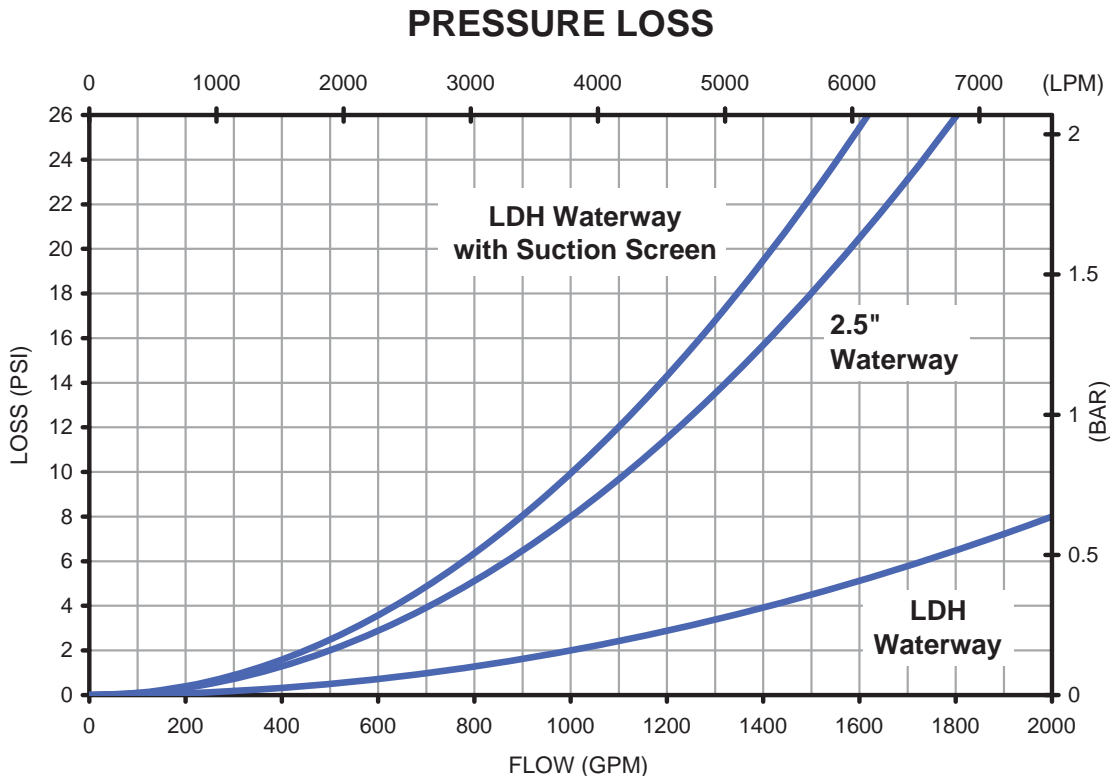

6.0 MAINTENANCE

This valve should be disconnected, cleaned and visually inspected inside and out at least quarterly for proper function per NFPA 1962 section 8.2, or as water quality and use may require. Moving parts such as handles, valve ball and couplings should be checked for smooth and free operation. Seals shall be greased as needed with a silicone-based grease such as Dow Corning 112. Any scrapes that expose bare aluminum should be cleaned and touched up with enamel paint such as Rust-Oleum.

In particular assure that:

- There is no damage such as cracks or dents
- There is no corrosion
- The waterway is clear of obstructions
- Pressure relief valve setting indications are readable
- The pressure relief valve opens at the set pressure (See LIA-202 for pressure relief valve test procedures)

Replace any missing or damaged parts before returning to service. Any repaired device must be tested before being placed in service.



Dissimilar metals coupled together can cause galvanic corrosion that can result in the inability to unscrew the threads or complete loss of thread engagement over time. Per NFPA 1962 (2008 edition), if dissimilar metals are left coupled together, an anti-corrosive lubricant should be applied to the threads. Also the couplings should be disconnected and inspected at least quarterly.



Any alterations to the device and its markings could diminish safety and constitute a misuse this product

7.0 EXPLODED VIEWS & PARTS LISTS

7.1 MANIFOLD VALVE

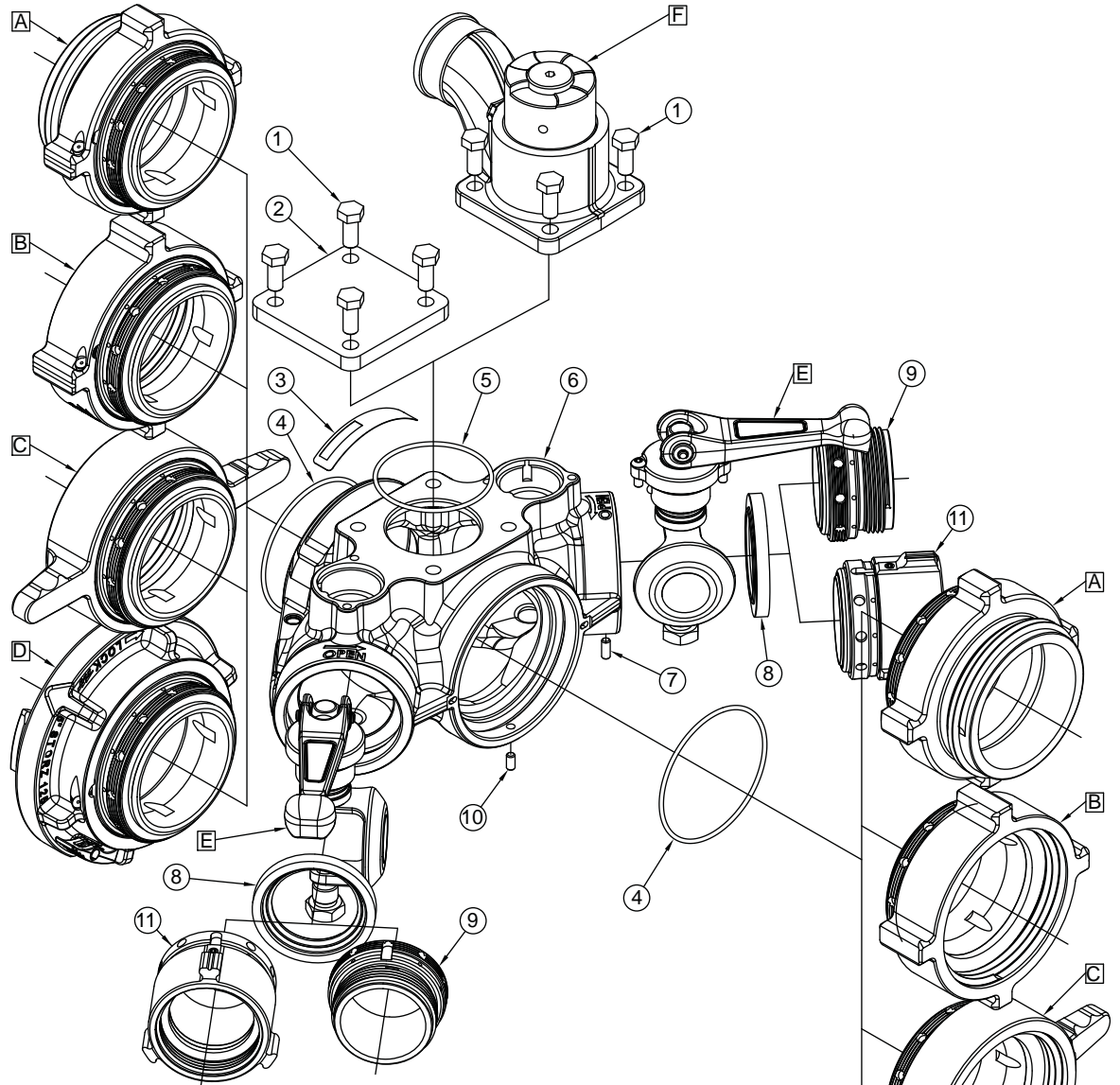

ITEM	DESCRIPTION	QTY	PART #
1	7/16-14 X 1 HEX HEAD BOLT	4	VT43-14HX1.0
2	LDH BLANK CAP	1	X631
3	VALVE LABEL	1	AY305
4	O-RING-243	2	VO-243
5	O-RING-236	1	VO-236
6	MANIFOLD VALVE BODY	1	A2005
7	1/4-20 X 5/8 SET SCREW	2	VT25-20SS625
8	VALVE SEAT	2	AY315
9	SIDE B ADAPTER 2 1/2 NH	2	AY360N
10	1/4-20 X 1/2 SET SCREW	2	VT25-20SS500
11	SIDE B ADAPTER HSBGM30	2	AY365
	COUPLING 2.5"NH	2	P197N
	3/16" SS BALL	96	V2120
	GASKET - 2.5"	2	V3190
	O-RING-151	2	VO-151
	1/4-28 X 1/4 SOCKET SET SCREW	2	VT25-28SS250

ITEM	DESCRIPTION	QTY	PART #
A	COUPLING - MALE HOSE THREADS	-	SEE SECTION 7.10.1
B	COUPLING - FEMALE HOSE THREADS ROCKER LUG	-	SEE SECTION 7.10.2
C	COUPLING - FEMALE HOSE THREADS LONG HANDLE	-	SEE SECTION 7.10.3
D	COUPLING - STORZ	-	SEE SECTION 7.10.4
E	2.5" VALVE HANDLE SUBASSEMBLY	-	SEE SECTION 7.5
F	PRESSURE RELIEF VALVE	-	SEE SECTION 7.8

7.2 IN-LINE VALVE

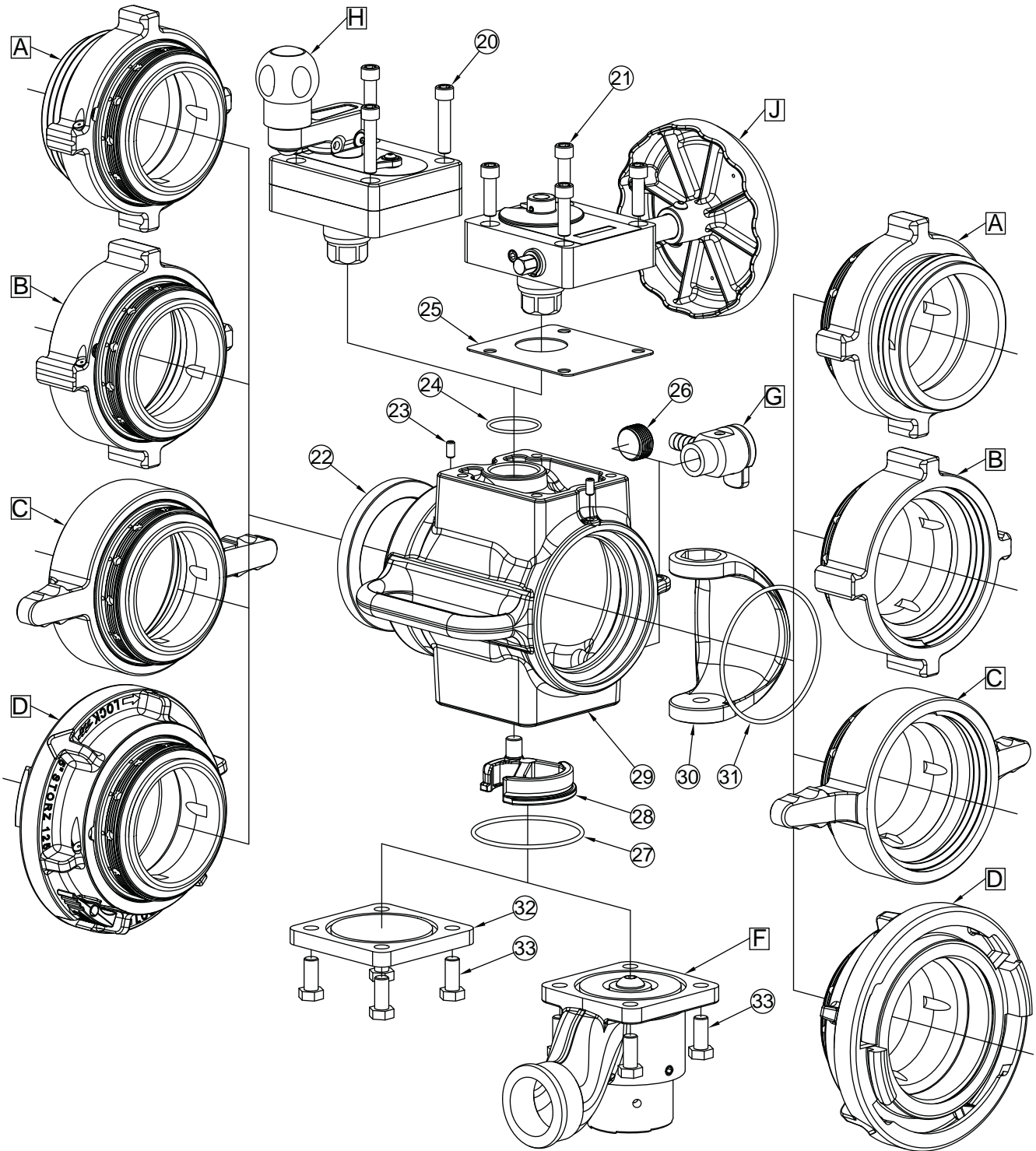

7.2 IN-LINE VALVE PARTS SET

ITEM	DESCRIPTION	QTY	PART #
20	3/8-16 X 1-3/4 SOCKET HEAD SCREW	4	VT37-16SH1.7
21	3/8-16 X 1-1/4 SOCKET HEAD SCREW	4	VT37-16SH1.2
22	VALVE SEAT	1	A1520
23	1/4-20 X 1/2" SET SCREW	2	VT25-20SS500
24	O-RING-128	1	VO-128
25	GEARBOX COVER	1	A1030
26	3/4"NPTM HEX SOCKET PLUG	1	XG410
27	O-RING-236	1	VO-236
28	HOLLOW TRUNNION	1	A1514
29	IN-LINE VALVE BODY	1	A2000
30	HALF BALL	1	A1043S
31	O-RING-243	1	VO-243
32	LDH BLANK CAP	1	X631
33	7/16-14 X 1 HEX HEAD BOLT	4	VT43-14HX1.0
A	COUPLING - MALE HOSE THREADS	-	SEE SECTION 7.10.1
B	COUPLING - FEMALE HOSE THREADS ROCKER LUG	-	SEE SECTION 7.10.2
C	COUPLING - FEMALE HOSE THREADS LONG HANDLE	-	SEE SECTION 7.10.3
D	COUPLING - STORZ	-	SEE SECTION 7.10.4
F	PRESSURE RELIEF VALVE	-	SEE SECTION 7.8
G	DRAIN VALVE SUBASSEMBLY	-	SEE SECTION 7.9
H	PARALLEL SHAFT GEARBOX SUBASSEMBLY	-	SEE SECTION 7.7
J	STANDARD GEARBOX SUBASSEMBLY	-	SEE SECTION 7.6

7.3 3-WAY VALVED MANIFOLD

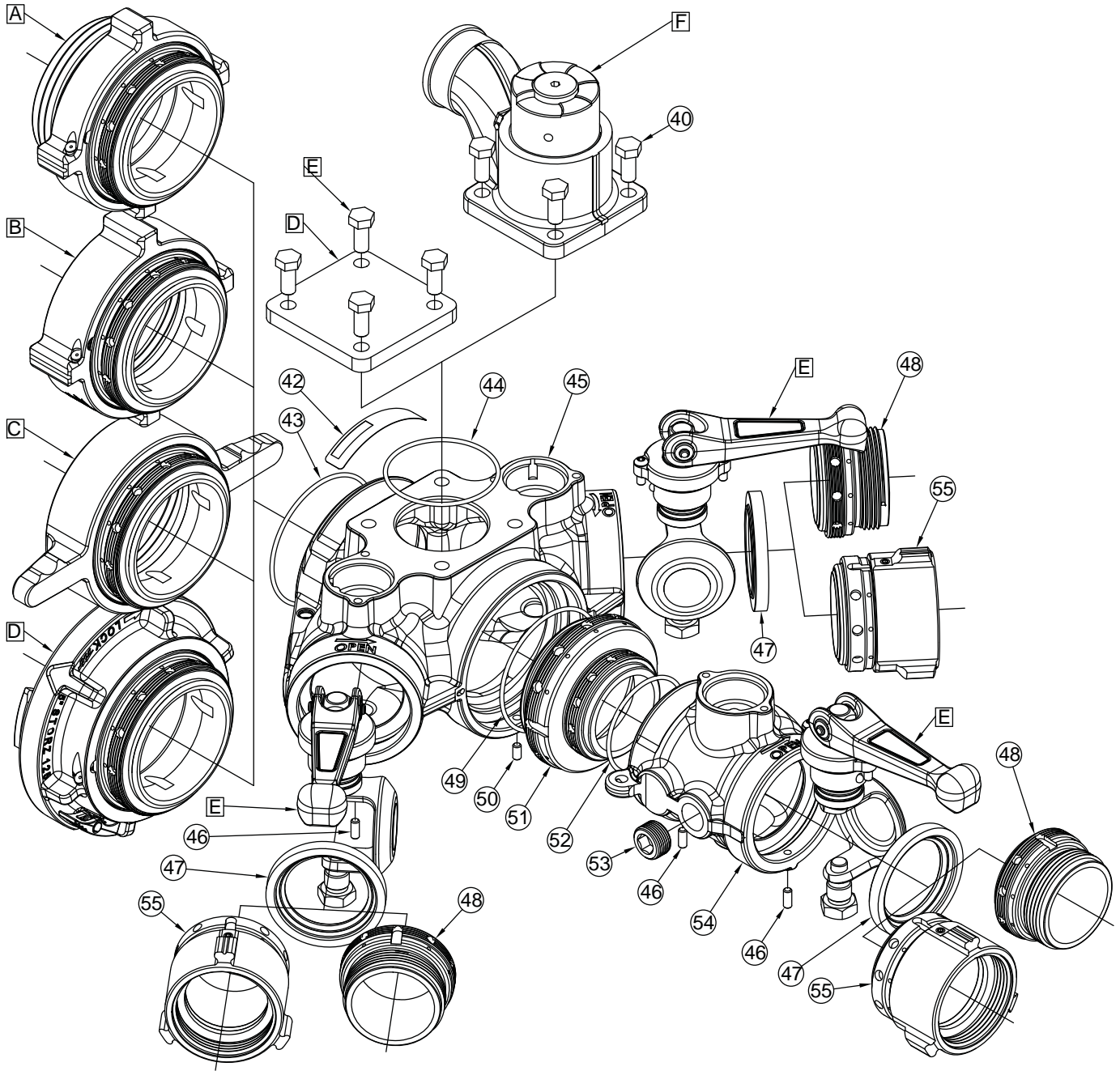

7.3 3-WAY VALVED MANIFOLD PARTS LIST

ITEM	DESCRIPTION	QTY	PART #
40	7/16-14 X 1 HEX HEAD BOLT	4	VT43-14HX1.0
41	LDH BLANK CAP	1	X631
42	VALVE LABEL	1	AY305
43	O-RING-243	1	VO-243
44	O-RING-236	1	VO-236
45	MANIFOLD VALVE BODY	1	A2005
46	1/4-20 X 5/8 SET SCREW	4	VT25-20SS625
47	VALVE SEAT	3	AY315
48	SIDE B ADAPTER 2 1/2 NH	3	AY360N
49	O-RING-241	1	VO-241
50	1/4-20 X 1/2 SET SCREW	2	VT25-20SS500
51	MATE CODE-RRM X 2.5" VALVE	1	A2025
52	O-RING-234	1	VO-234
53	3/4"NPTM HEX SOCKET PLUG	1	XG410
54	2.5" HYDRANT VALVE BODY	1	AY301
55	SIDE B ADAPTER HSBGM30	3	AY365
	COUPLING 2.5"NH	3	P197N
	3/16" SS BALL	144	V2120
	GASKET - 2.5"	3	V3190
	O-RING-151	3	VO-151
	1/4-28 X 1/4 SOCKET SET SCREW	3	VT25-28SS250
A	COUPLING - MALE HOSE THREADS	-	SEE SECTION 7.10.1
B	COUPLING - FEMALE HOSE THREADS ROCKER LUG	-	SEE SECTION 7.10.2
C	COUPLING - FEMALE HOSE THREADS LONG HANDLE	-	SEE SECTION 7.10.3
D	COUPLING - STORZ	-	SEE SECTION 7.10.4
E	2.5" VALVE HANDLE SUBASSEMBLY	-	SEE SECTION 7.5
F	PRESSURE RELIEF VALVE	-	SEE SECTION 7.8

7.4 4-WAY VALVED MANIFOLD

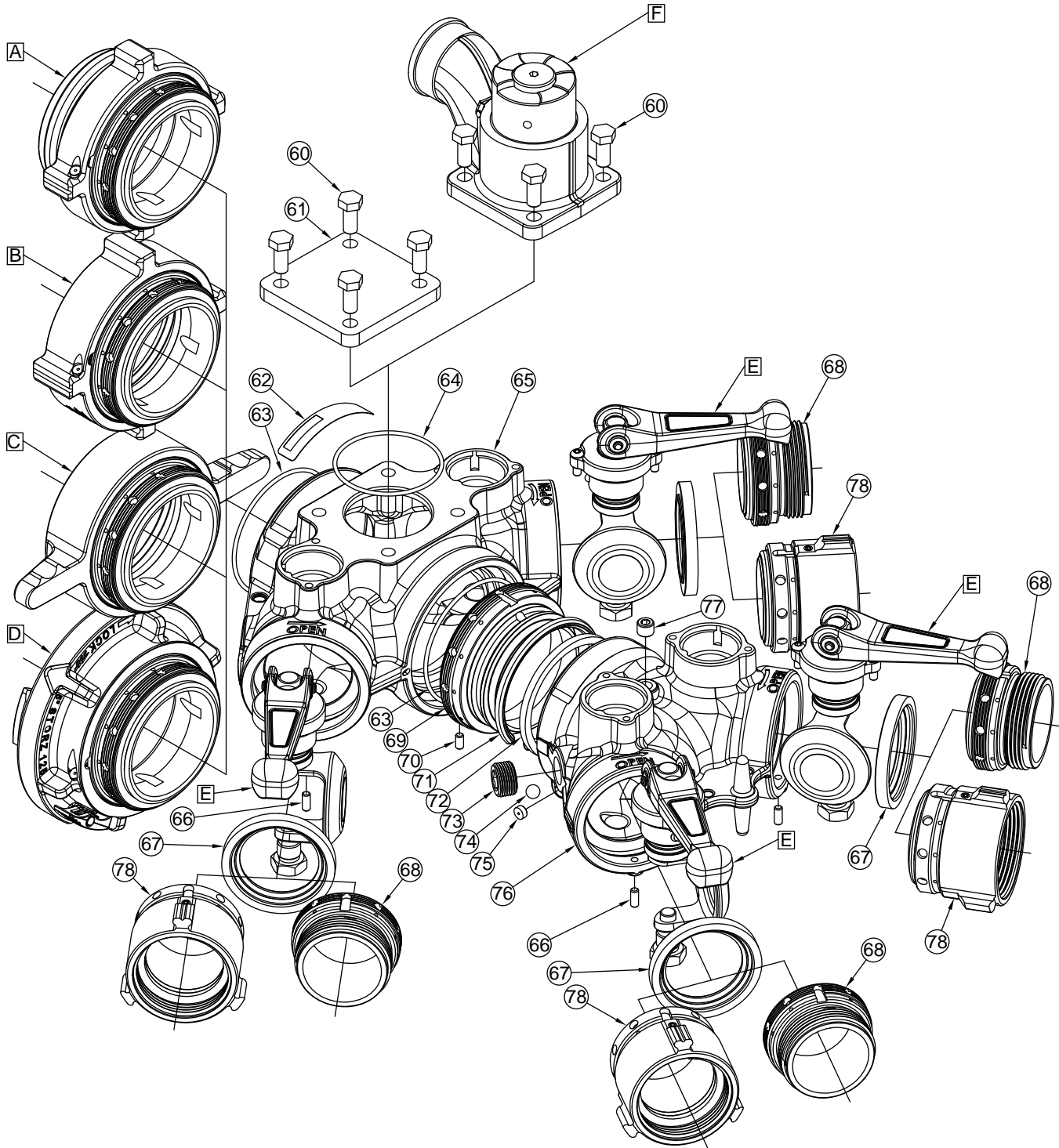

7.4 4-WAY VALVED MANIFOLD PARTS LIST

ITEM	DESCRIPTION	QTY	PART #
60	7/16-14 X 1 HEX HEAD BOLT	4	VT43-14HX1.0
61	LDH BLANK CAP	1	X631
62	VALVE LABEL	1	AY305
63	O-RING-243	2	VO-243
64	O-RING-236	1	VO-236
65	MANIFOLD VALVE BODY	1	A2005
66	1/4-20 X 5/8 SET SCREW	4	VT25-20SS625
67	VALVE SEAT	4	AY315
68	SIDE B ADAPTER 2 1/2 NH	4	AY360N
69	MATE CODE-RRM MODIFIED X PSM4.25	1	A2014
70	1/4-20 X 1/2 SET SCREW	2	VT25-20SS500
71	PLASTIC STRIP 4.25"	1	A1292
72	CUP SEAL LOADED	1	A1597
73	3/4"NPTM HEX SOCKET PLUG	1	XG410
74	7/16" STAINLESS 302 BALL	1	VB437
75	PORT PLUG	1	A1299
76	GATED WYE BODY	1	AY300
77	1/4"NPT PLUG	1	VFSP2M-SS
78	SIDE B ADAPTER HSBGM30	4	AY365
	COUPLING 2.5"NH	4	P197N
	3/16" SS BALL	192	V2120
	GASKET - 2.5"	4	V3190
	O-RING-151	4	VO-151
	1/4-28 X 1/4 SOCKET SET SCREW	4	VT25-28SS250
A	COUPLING - MALE HOSE THREADS	-	SEE SECTION 7.10.1
B	COUPLING - FEMALE HOSE THREADS ROCKER LUG	-	SEE SECTION 7.10.2
C	COUPLING - FEMALE HOSE THREADS LONG HANDLE	-	SEE SECTION 7.10.3
D	COUPLING - STORZ	-	SEE SECTION 7.10.4
E	2.5" VALVE HANDLE SUBASSEMBLY	-	SEE SECTION 7.5
F	PRESSURE RELIEF VALVE	-	SEE SECTION 7.8

7.5 2.5" VALVE HANDLE MECHANISM

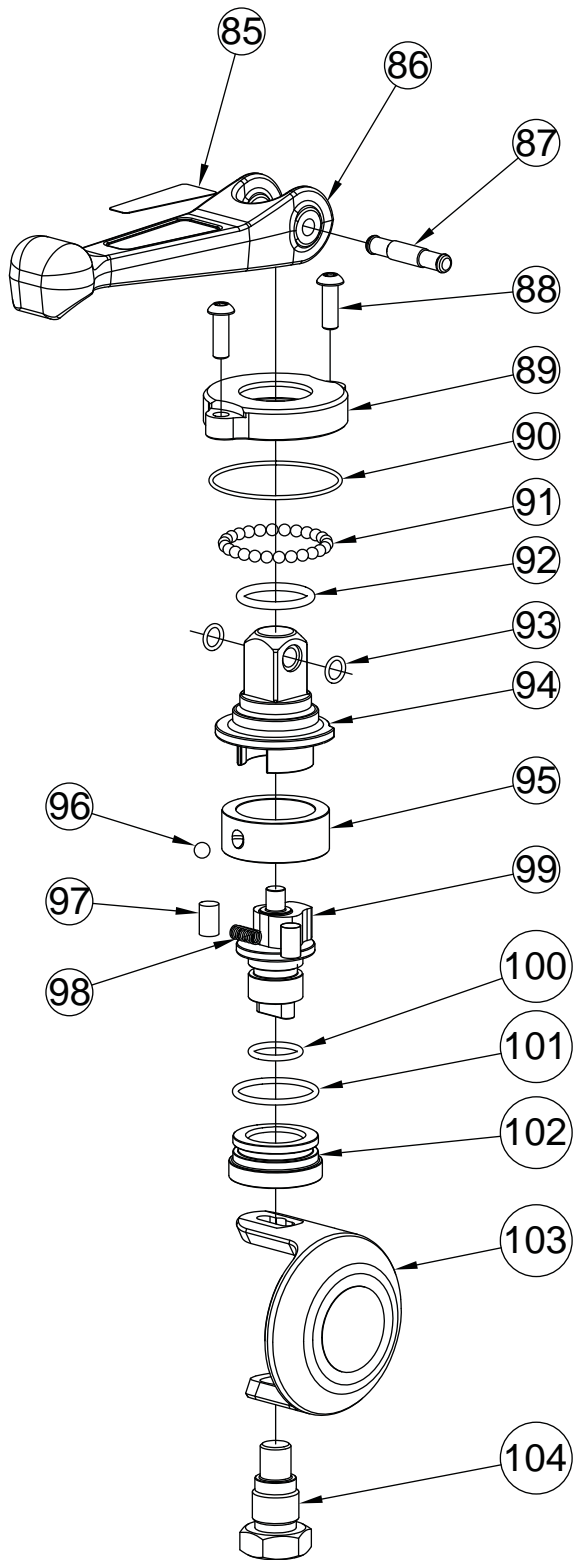

ITEM	DESCRIPTION	QTY	PART #
85	HANDLE LABEL - BLUE	1	AY342-BLU
	HANDLE LABEL - RED		AY342-RED
	HANDLE LABEL - WHITE		AY342-WHT
86	VALVE HANDLE	1	AY340
87	HANDLE PIVOT PIN	1	AY345
88	1/4-20 X 3/4 SCREW	2	VT25-20BH750
89	TRUNNION RETAINER	1	AY354
90	O-RING-033	1	VO-033
91	3/16" ACETAL BALL	26	V2115
92	O-RING-214	1	VO-234
93	O-RING-011	2	VO-011
94	OUTER UPPER TRINNION	1	AY320
95	FLOATING RING	1	AY352
96	1/4" SS BALL	1	V2125
97	DOWEL PIN	2	VP312X.50
98	SPRING	1	HC115
99	INNER UPPER TRUNNION	1	AY350
100	O-RING-115	2	VO-115
101	O-RING-123	1	VO-123
102	INNER BUSHING	1	AY351
103	HALF BALL	1	AY310
104	LOWER TRUNNION	1	AY353
	LOWER TRUNNION - LONG EXTENSION		AY355
	LOWER TRUNNION - SHORT EXTENSION		AY356

7.6 STANDARD GEARBOX

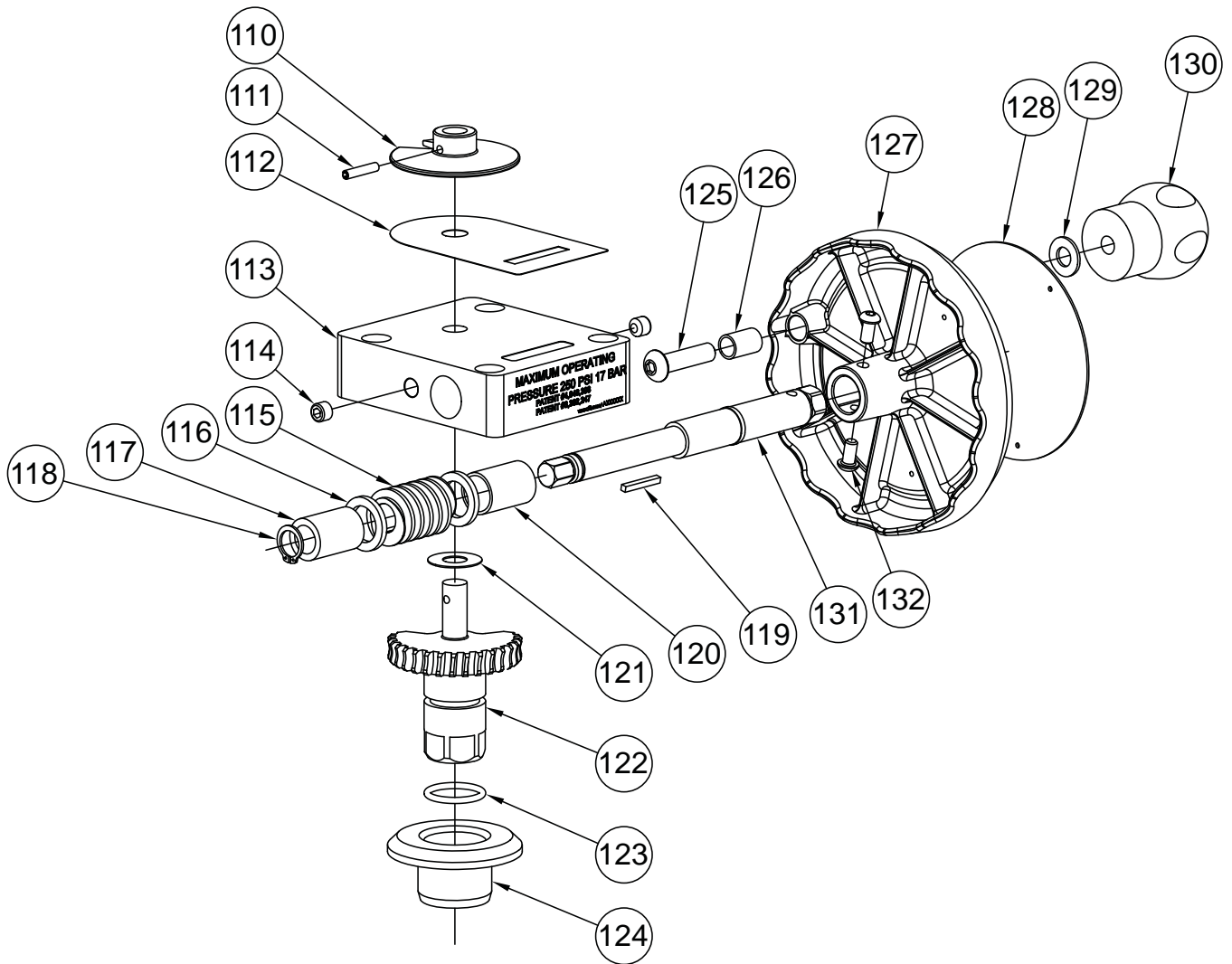

ITEM	DESCRIPTION	QTY	PART #
110	POSITION INDICATOR	1	A1517
111	SPIROL PIN	1	V1900
112	LABEL	1	A1301
113	GEARBOX 250PSI	1	A1506
114	3/8-16 X 5/16 SOCKET SET SCREW	1	VT37-16SS312
115	12 DP WORM	1	X220
116	THIN WASHER	1	A1530
117	SMALL BUSHING	1	A1525
118	RETAINING RING 15MM EXTERNAL	1	VR4275
119	KEY	1	X225
120	LARGE BUSHING	1	A1526
121	GEAR THRUST WASHER	1	A1502

ITEM	DESCRIPTION	QTY	PART #
122	INTEGRAL WORM GEAR & TRUNNION	1	A1501
123	O-RING-214	1	VO-241
124	GEAR SPACER	1	A1511
125	3/8-16 X 1-1/2 BUTTON HEAD SCREW	1	VT37-16BH1.5
126	CRANK BUSHING	1	A1513
127	HANDWHEEL	1	X281
128	HANDWHEEL LABEL	1	A1306
129	WASHER	1	VW812X406-65
130	KNOB	1	A1512
131	CRANK SHAFT	1	A1510
132	1/4-20 X 1/2 BUTTON HEAD SCREW	2	VT25-20BH500

7.7 PARALLEL DRIVE GEARBOX

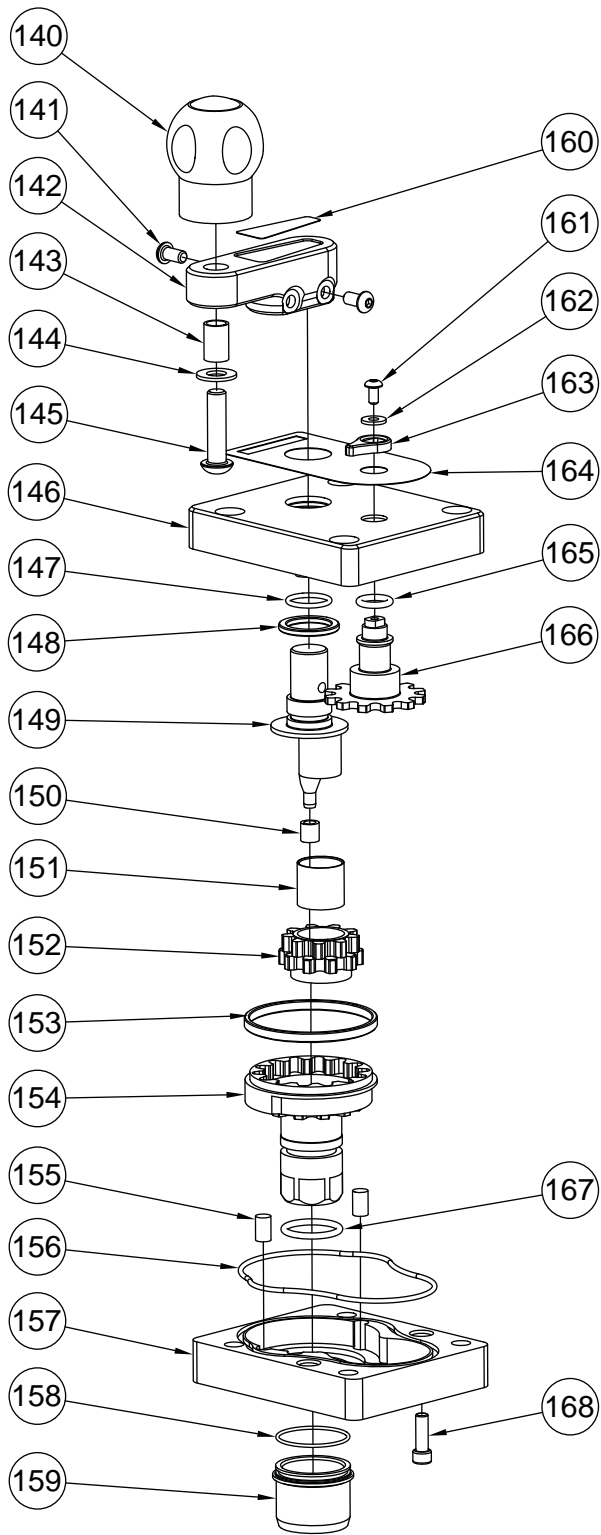

ITEM	DESCRIPTION	QTY	PART #
140	KNOB	1	A1512
141	1/4-20 X 1/2 SCREW	2	VT25-20BH500
142	CRANK	1	A1559
143	CRANK BUSHING	1	A1513
144	WASHER	1	VW812X406-65
145	3/8-16 X 1-1/2 SCREW	1	VT37-16BH1.5
146	GEARBOX	1	A1550
147	O-RING-116	1	VO-116
148	SPACER	1	A1556
149	DRIVE SHAFT	1	A1555
150	NYLON BUSHING	1	AY307
151	GEAR BUSHING	1	A1548
152	DOUBLE GEAR	1	A1554
153	TRUNNION BUSHING	1	A1549
154	INNER TRUNNION	1	A1553
155	DOWEL PIN	2	VP312X.50
156	O-RING-154	1	VO-154
157	SUBPLATE	1	A1551
158	O-RING-028	1	VO-028
159	INNER BUSHING	1	A1552
160	HANDLE LABEL - BLUE	1	AY342-BLU
	HANDLE LABEL - RED		AY342-RED
	HANDLE LABEL - WHITE		AY342-WHT
161	10-24 3/8 SCREW	1	VT10-24BH375
162	WASHER	1	VW500X203-60
163	POSITION INDICATOR	1	A1558
164	LABEL	1	A1550L
165	O-RING 206	1	VO-206
166	INDICATOR GEAR	1	A1557
167	O-RING 214	1	VO-214
168	1/4-20 X 3/4 SCREW	1	VT25-20SH750

7.8 PRESSURE RELIEF VALVE

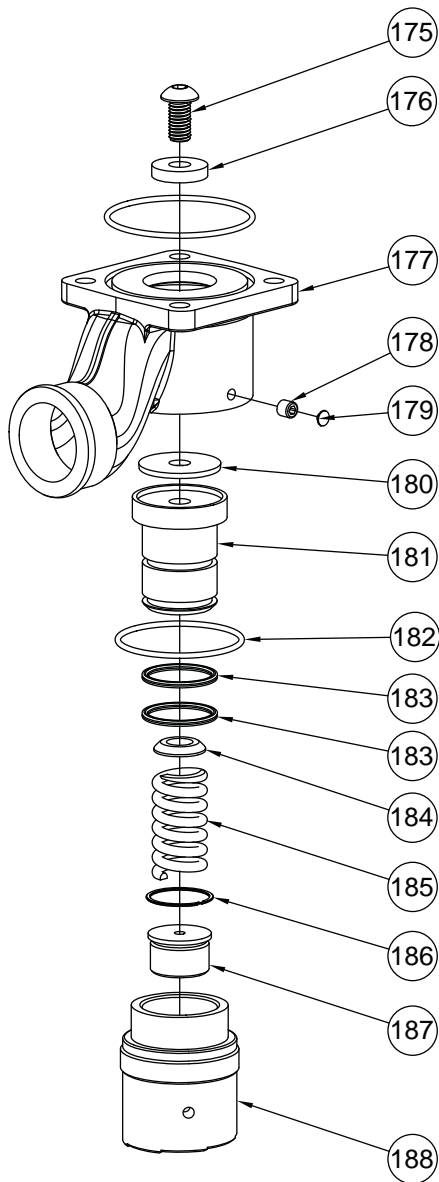

A1640 PRESSURE RELIEF VALVE SUBASSEMBLY			
ITEM	DESCRIPTION	QTY	PART #
175	1/2-13 X 1.0 SCREW	1	VT50-13BH1.0
176	DEBRIS WASHER	1	A1169
177	HOUSING W/OUT THREADS	1	A1150
178	5/16-18 X 3/8 SET SCREW	1	VT31-18SS375
179	SET SCREW PLUG	1	A1162
180	VALVE SEAT PRV	1	A1168
181	PISTON	1	A1160
182	O-RING-232	1	VO-232
183	QUAD-RING 222	2	VOQ-4222
184	SPRING SEAT	1	A1166
185	RELIEF SPRING	1	A1170
186	SMALLEY RING	1	V4210
187	ADJUSTING SCREW	1	A1167
188	SPRING HOUSING 200 MAX	1	A1164

7.9 AIR VENT/DRAIN VALVE

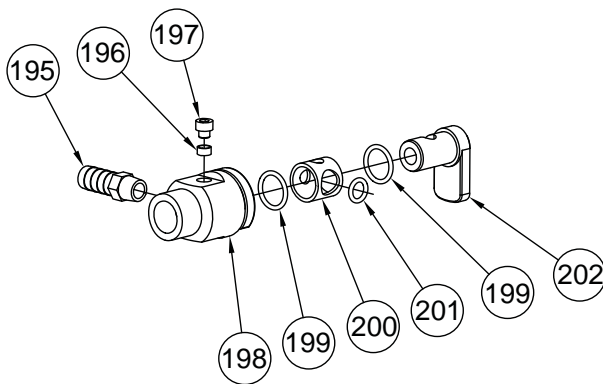

A1621 DRAIN VALVE SUBASSEMBLY			
ITEM	DESCRIPTION	QTY	PART #
195	1/2" BARB X 1/4"NPTM NIPPLE	1	XX329
196	FOLLOWER	1	U251
197	3/8-24 X 3/8 DOG POINT	1	H515
198	DRAIN HOUSING	1	A1543
199	O-RING 115	2	VO-115
200	DRAIN SLEEVE	1	A1541
201	O-RING-110	1	VO-110
202	DRAIN LEVER	1	A1542

7.10 INLET/OUTLET OPTIONS

7.10.1 COUPLING - MALE HOSE THREADS

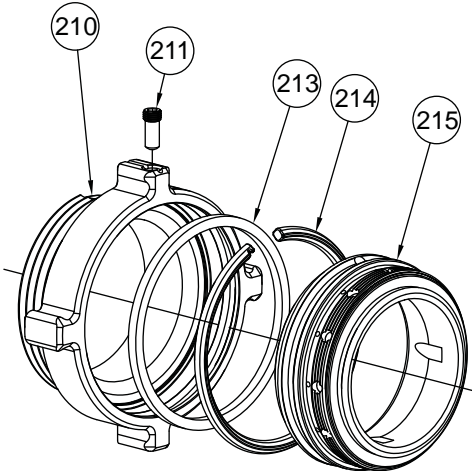

MALE HOSE THREADS				
ITEM	DESCRIPTION	4.0"	4.5"	5.0"
210	SPOUT	A4620N	A4625N	A4630N
211	LOCK-OUT SCREW	A1294	A1294	A1294
213	CUP SEAL LOADED	A1596	A1596	A1596
214	PLASTIC STRIP	A1291	A1291	A1291
215	MATE	A2016	A2016	A2016

7.10.2 COUPLING - FEMALE HOSE THREADS ROCKER LUG

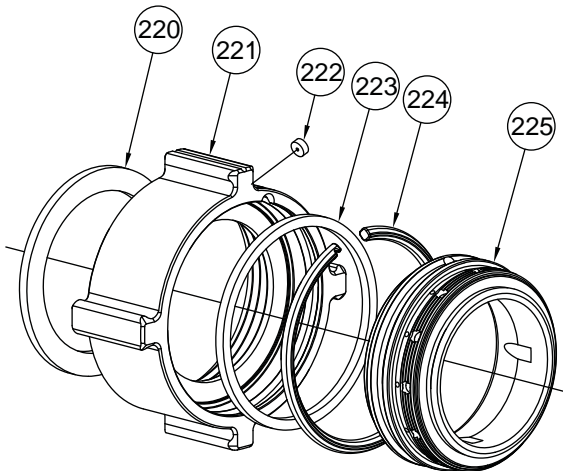

FEMALE HOSE THREADS ROCKER LUGS				
ITEM	DESCRIPTION	4.0"	4.5"	5.0"
220	GASKET	V1398	V3210	V3220
221	COUPLING	A4460N	A4665N	A4670N
222	PORT PLUG	A1299	A1299	A1299
223	CUP SEAL	A1596	A1596	A1596
224	PLASTIC STRIP	A1291	A1291	A1291
225	MATE	A2016	A2016	A2016

7.10.3 COUPLING - FEMALE HOSE THREADS LONG HANDLE

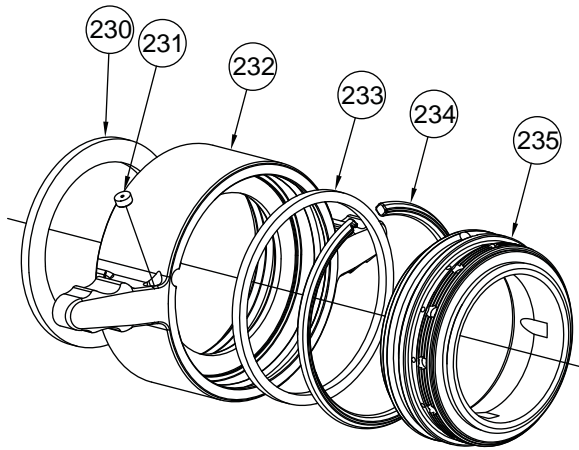

FEMALE HOSE THREADS LONG HANDLES				
ITEM	DESCRIPTION	4.0"	4.5"	5.0"
230	GASKET	V3198	V3210	V3220
231	PORT PLUG	A1299	A1299	A1299
232	COUPLING	A4560N	A4565N	A4570N
233	CUP SEAL	A1596	A1596	A1596
234	PLASTIC STRIP	A1291	A1291	A1291
235	MATE	A2016	A2016	A2016

7.10.4 COUPLING - STORZ

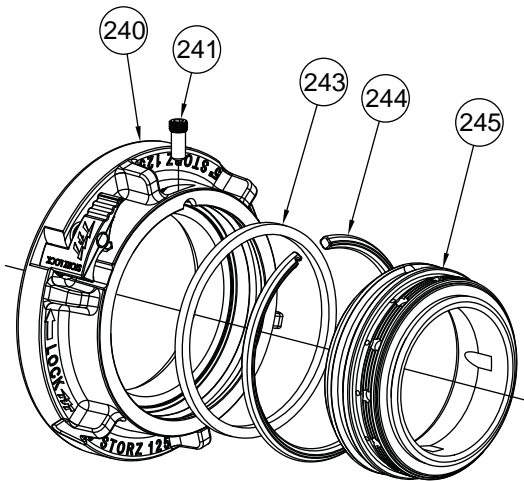

STORZ COUPLING			
ITEM	DESCRIPTION	4.0"	5.0"
240	STORZ SUBASSEMBLY	A4124	A4125
241	LOCK-OUT SCREW	A1294	A1294
243	CUP SEAL LOADED	A1597	A1596
244	PLASTIC STRIP	A1292	A1291
245	MATE	A2015	A2016

8.0 ANSWERS TO YOUR QUESTIONS

We appreciate the opportunity of serving you and making your job easier. If you have any problems or questions, our toll-free "Hydraulics Hotline", 800-348-2686, is normally available to you 24 hours a day, 7 days a week.

9.0 WARRANTY

Task Force Tips, Inc., 3701 Innovation Way, Valparaiso, Indiana 46383-9327 USA ("TFT") warrants to the original purchaser of its LDH Valved Appliances ("equipment"), and to anyone to whom it is transferred, that the equipment shall be free from defects in material and workmanship during the five (5) year period from the date of purchase.

TFT's obligation under this warranty is specifically limited to replacing or repairing the equipment (or its parts) which are shown by TFT's examination to be in a defective condition attributable to TFT. To qualify for this limited warranty, the claimant must return the equipment to TFT, at 3701 Innovation Way, Valparaiso, Indiana 46383-9327 USA, within a reasonable time after discovery of the defect. TFT will examine the equipment. If TFT determines that there is a defect attributable to it, TFT will correct the problem within a reasonable time. If the equipment is covered by this limited warranty, TFT will assume the expenses of repair.

If any defect attributable to TFT under this limited warranty cannot be reasonably cured by repair or replacement, TFT may elect to refund the purchase price of the equipment, less reasonable depreciation, in complete discharge of its obligations under this limited warranty. If TFT makes this election, claimant shall return the equipment to TFT free and clear of any liens and encumbrances.

This is a limited warranty. The original purchaser of the equipment, any person to whom it is transferred, and any person who is an intended or unintended beneficiary of the equipment, shall not be entitled to recover from TFT any consequential or incidental damages for injury to person and/or property resulting from any defective equipment manufactured or assembled by TFT. It is agreed and understood that the price stated for the equipment is in part consideration for limiting TFT's liability. Some states do not allow the exclusion or limitation of incidental or consequential damages, so the above may not apply to you.

TFT shall have no obligation under this limited warranty if the equipment is, or has been, misused or neglected (including failure to provide reasonable maintenance) or if there have been accidents to the equipment or if it has been repaired or altered by someone else.

THIS IS A LIMITED EXPRESS WARRANTY ONLY. TFT EXPRESSLY DISCLAIMS WITH RESPECT TO THE EQUIPMENT ALL IMPLIED WARRANTIES OF MERCHANTABILITY AND ALL IMPLIED WARRANTIES OF FITNESS FOR A PARTICULAR PURPOSE. THERE IS NO WARRANTY OF ANY NATURE MADE BY TFT BEYOND THAT STATED IN THIS DOCUMENT.

This limited warranty gives you specific legal rights, and you may also have other rights which vary from state to state.