



MANUAL: Chimney Snuffer

INSTRUCTIONS FOR SAFE OPERATION AND MAINTENANCE

⚠ WARNING

Read instruction manual before use. Operation of this device without understanding the manual and receiving proper training is a misuse of this equipment. A person who has not read and understood all operating and safety instructions is not qualified to operate the Chimney Snuffer.

This instruction manual is intended to familiarize firefighters and maintenance personnel with the operation, servicing and safety procedures associated with the Chimney Snuffer.

This manual should be kept available to all operating and maintenance personnel.

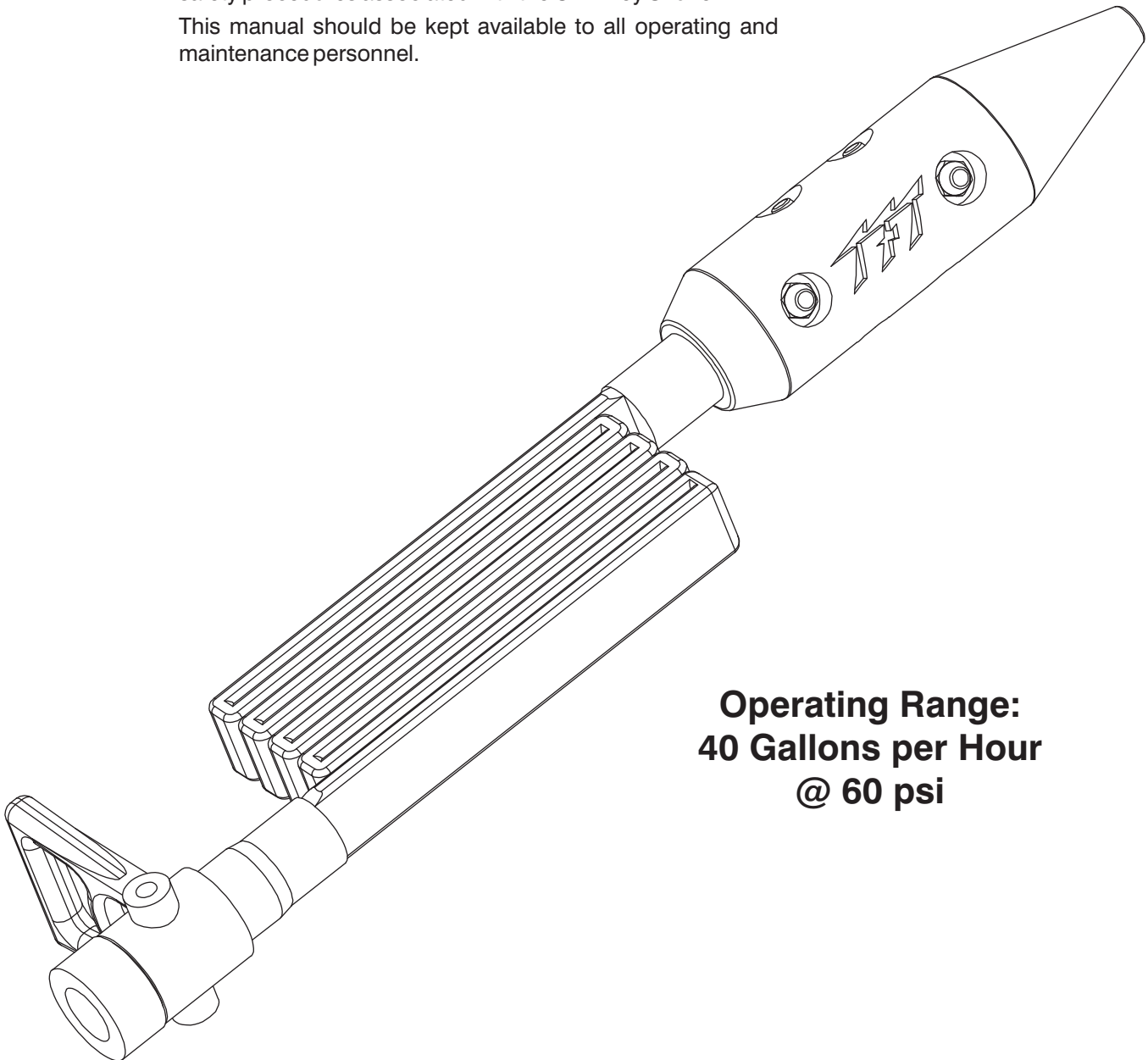

**Operating Range:
40 Gallons per Hour
@ 60 psi**

TASK FORCE TIPS, Inc.
MADE IN USA • www.tft.com

2800 E. Evans Ave, Valparaiso, IN 46383-6940 USA
800-348-2686 • 219-462-6161 • Fax 219-464-7155

1.0 MEANING OF SAFETY SIGNAL WORDS

A safety related message is identified by a safety alert symbol and a signal word to indicate the level of risk involved with a particular hazard. Per ANSI standard Z535.4-1998 the definitions of the three signal words are as follows:

- ▲ DANGER** DANGER indicates an imminently hazardous situation which, if not avoided, will result in death or serious injury.
- ▲ WARNING** WARNING indicates a potentially hazardous situation which, if not avoided, could result in death or serious injury.
- ▲ CAUTION** CAUTION indicates a potentially hazardous situation which, if not avoided, may result in minor or moderate injury.

2.0 GENERAL INFORMATION

The Task Force Tips Chimney Snuffer is designed to quench chimney fires with a fine spray to minimize water damage. Eight strategically placed nozzles deliver 40 gallons per hour (150 L/hour) at 60 psi (4 Bar). The nozzle and valve are constructed of durable hard anodized aluminum, stainless steel, rubber and engineering grade polymers. 1.0" NH (25mm) hose thread is standard on the Chimney Snuffer head, hose and valve (National Hose Threads per NFPA #1963).

- ▲ WARNING** This equipment is intended for use by trained personnel for firefighting. Their use for other purposes may involve hazards not addressed by this manual. Seek appropriate guidance and training to reduce risk of injury.
- ▲ CAUTION** Nozzle must be properly connected. Mismatched or damaged threads may cause nozzle to leak or uncouple under pressure and could cause injury.
- ▲ CAUTION** Do not couple aluminum to brass. Dissimilar metals coupled together can cause galvanic corrosion that can result in inability to unscrew threads or complete loss of thread engagement.

3.0 SAFETY

- ▲ DANGER** Injury or death can occur from falling off rooftops. Roof surfaces can become slippery when wet or icy. Evaluate risk before going up onto rooftops. Seek proper training to reduce risk of injury.
- ▲ WARNING** An inadequate supply of nozzle pressure or flow will cause an ineffective stream and can result in injury. Call 800-348-2686 for assistance.
- ▲ CAUTION** Nozzles falling from rooftops can injure persons below. Clear bystanders from around roof line before going up onto roofs. Emergency personnel working below roof line should wear approved headgear.
- ▲ CAUTION** Sand or mineral deposits can reduce the flow of the Chimney Snuffer resulting in an ineffective stream. Check stream before going onto rooftop. In the event of an ineffective stream it may be necessary to retreat to a safe area and clean the sand or mineral deposits.

4.0 USE WITH SALT WATER

Use with salt water is permissible provided nozzle is thoroughly cleaned with fresh water after each use. The service life of the nozzle may be shortened due to the effects of corrosion and is not covered under warranty.

5.0 FIREGROUND USE

IT IS THE RESPONSIBILITY OF THE INDIVIDUAL FIRE DEPARTMENT OR AGENCY TO DETERMINE PHYSICAL CAPABILITIES AND SUITABILITY FOR AN INDIVIDUAL'S USE OF THIS EQUIPMENT.

Many factors contribute to the extinguishment of a fire. Among the most important is delivering water at a flow rate sufficient to absorb heat faster than is being generated. The flow rate depends largely on the pump discharge pressure and hose friction loss. The pump discharge pressure may be found by use of the chart on the last page. It can also be calculated using a hydraulic equation such as:

$$PDP = NP + FL + DL + EL$$

PDP = Pump discharge pressure in PSI

NP = Nozzle pressure in PSI

FL = Hose friction loss in PSI

DL = Device loss in PSI

EL = Elevation loss in PSI

For additional information on calculating specific hose layouts, consult an appropriate fire-service training manual, A Firefighters Guide to Nozzles published by Task Force Tips, or call TFT's "Hydraulics Hotline" at 800-348-2686, request document #LTT-110.

6.0 EXPLODED VIEW & PART LIST

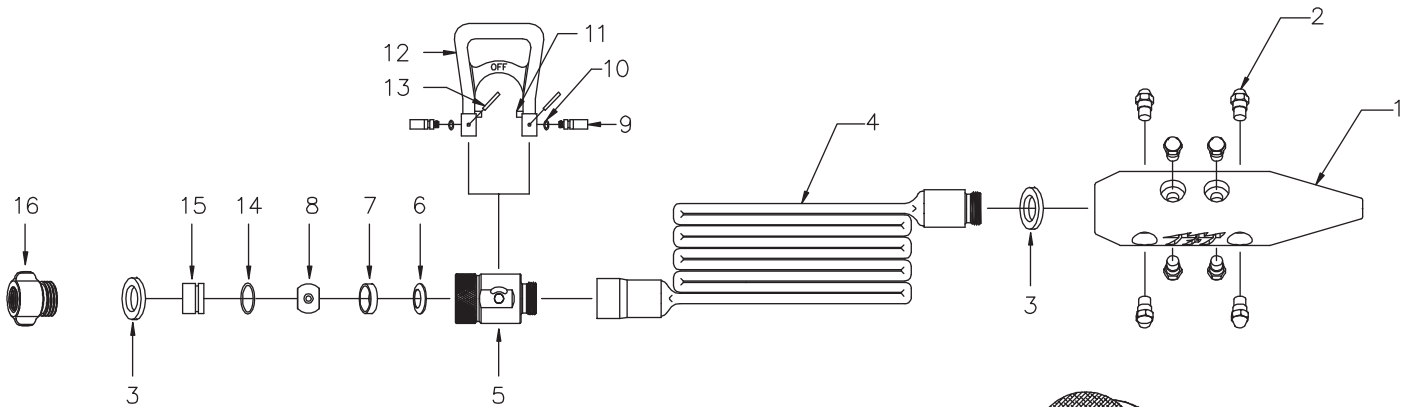

REF #	PART #	DESCRIPTION	QTY
1	A3520	CHIMNEY SNUFFER HEAD	1
2	A3540	NOZZLES	8
3	V3040	GASKET	2
4	A3550	HOSE 25 FEET 1.0"NH	1
5	D07522N	VALVE BODY 1.0"NH	1
6	D07590	SPRING BELLEVILLE	1
7	D07570	FRONT SEAT	1
8	D07530	BALL	1
9	D07540	TRUNNION	2
10	VO-010	O-RING	2
11	D07550	STOP PIN	2
12	D07560	SHUTOFF HANDLE	1
13	V1900	SPIROL PIN	2
14	VO-120	O-RING	1
15	D07582	REAR SEAT	1
16	A3560	GARDEN HOSE ADAPTOR	1
17	A3530	CHIMNEY SNUFFER BAG	1

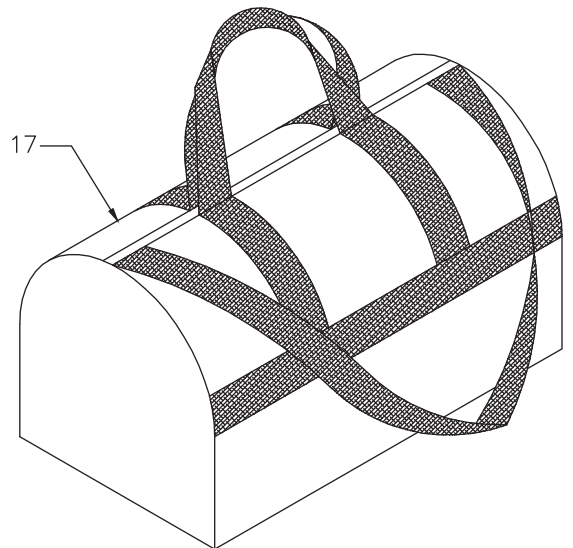

7.0 INSPECTION AND MAINTENANCE

The Chimney Snuffer is designed and manufactured to be damage resistant and require minimal maintenance. However, as the primary firefighting tool upon which your life depends, it should be treated accordingly.

Nozzle must be inspected before each use for proper operation and function according to this checklist:

- None of the nozzle jets are clogged
- There is no obvious damage such as missing, broken or loose parts, etc
- The coupling is tight and leak free
- The valve operates smoothly and shuts off water flow completely
- There is no major damage to the Chimney Snuffer head

CAUTION Before each use the Chimney Snuffer must be inspected for proper operation and function according to inspection criteria above. Any nozzle that fails inspection is dangerous to use and must be repaired before using. Operating a nozzle that fails any part of the inspection is a misuse of this equipment.

CAUTION Performance tests shall be conducted on the Chimney Snuffer after a repair, or anytime a problem is reported to verify operation in accordance with Task Force Tips test procedures. Consult factory for the procedure that corresponds to the model of the nozzle. Any equipment which fails the related test criteria should be removed from service immediately. Equipment can be returned to the factory for service and testing.

CAUTION Any alterations to the Chimney Snuffer constitutes a misuse of this product and could diminish safety.

8.0 WARRANTY

Task Force Tips, Inc., 2800 East Evans Avenue, Valparaiso, Indiana 46383-6940 ("TFT") warrants to the original purchaser of its Chimney Snuffer ("equipment"), and to anyone to whom it is transferred, that the equipment shall be free from defects in material and workmanship during the five (5) year period from the date of purchase.

TFT's obligation under this warranty is specifically limited to replacing or repairing the equipment (or its parts) which are shown by TFT's examination to be in a defective condition attributable to TFT. To qualify for this limited warranty, the claimant must return the equipment to TFT, at 2800 East Evans Avenue, Valparaiso, Indiana 46383-6940, within a reasonable time after discovery of the defect. TFT will examine the equipment. If TFT determines that there is a defect attributable to it, TFT will correct the problem within a reasonable time. If the equipment is covered by this limited warranty, TFT will assume the expenses of repair.

If any defect attributable to TFT under this limited warranty cannot be reasonably cured by repair or replacement, TFT may elect to refund the purchase price of the equipment, less reasonable depreciation, in complete discharge of its obligations under this limited warranty. If TFT makes this election, claimant shall return the equipment to TFT free and clear of any liens and encumbrances.

This is a limited warranty. The original purchaser of the equipment, any person to whom it is transferred, and any person who is an intended or unintended beneficiary of the equipment, shall not be entitled to recover from TFT any consequential or incidental damages for injury to person and/or property resulting from any defective equipment manufactured or assembled by TFT. It is agreed and understood that the price stated for the equipment is in part consideration for limiting TFT's liability. Some states do not allow the exclusion or limitation of incidental or consequential damages, so the above may not apply to you.

TFT shall have no obligation under this limited warranty if the equipment is, or has been, misused or neglected (including failure to provide reasonable maintenance) or if there have been accidents to the equipment or if it has been repaired or altered by someone else.

THIS IS A LIMITED EXPRESS WARRANTY ONLY. TFT EXPRESSLY DISCLAIMS WITH RESPECT TO THE EQUIPMENT ALL IMPLIED WARRANTIES OF MERCHANTABILITY AND ALL IMPLIED WARRANTIES OF FITNESS FOR A PARTICULAR PURPOSE. THERE IS NO WARRANTY OF ANY NATURE MADE BY TFT BEYOND THAT STATED IN THIS DOCUMENT.

This limited warranty gives you specific legal rights, and you may also have other rights which vary from state to state.

TASK FORCE TIPS, Inc.
MADE IN USA • www.tft.com

2800 E. Evans Ave, Valparaiso, IN 46383-6940 USA
800-348-2686 • 219-462-6161 • Fax 219-464-7155