



# MANUAL: Valve Under Monitor (VUM) Valve Under Monitor Remote Control (VUM RC)

## INSTRUCTIONS FOR INSTALLATION, SAFE OPERATION AND MAINTENANCE

### **WARNING**

Understand manual before use. Operation of this device without understanding the manual and receiving proper training is a misuse of this equipment. Obtain safety information at [www.tft.com/serial-number](http://www.tft.com/serial-number)

This instruction manual is intended to familiarize firefighters and maintenance personnel with the operation, servicing and safety procedures associated with the Valve Under Monitor or Valve Under Monitor RC.

This manual should be kept available to all operating and maintenance personnel.

### SAFE OPERATING RANGE:

- Up to 2500 gpm below 130 psi \*  
(9500 l/min @ 9 bar)
- Up to 2000 gpm below 200 psi \*  
(8000 l/min @ 14 bar)
- Up to 1500 gpm @ 300 psi maximum\*  
(6000 l/min @ 21 bar)

VUM RC six seconds from open to close  
Meets NFPA 1901 slow close requirement

**Hydrostatic Proof Test:**  
900 psi (62bar)

## SAMPLE CONFIGURATIONS

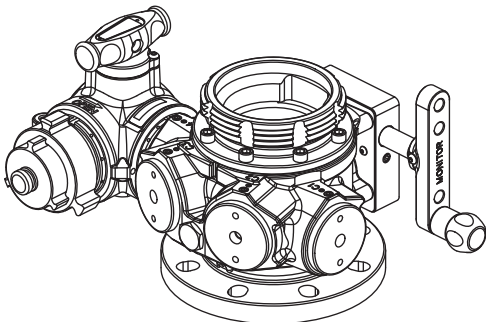

VUM with 4.5" Quick Connect  
and 2.5" Gated Elbow  
AKM1Q1113D

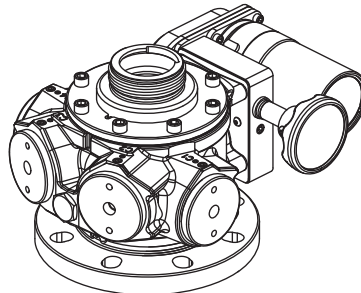

VUM RC with 2.5" Quick Connect  
and 2.5" Hose Thread Port  
AKE1T1511D

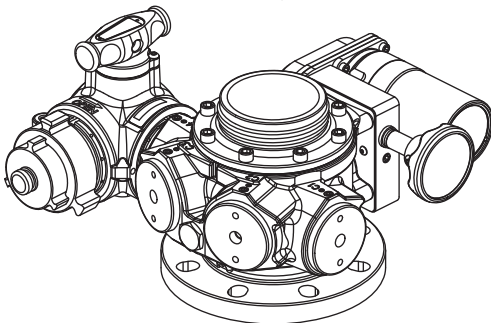

VUM RC with CODE-RPM outlet  
and 2.5" Gated Elbow  
AKE111113D

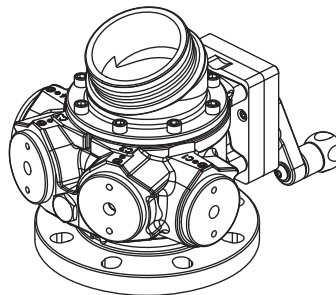

VUM with 22.5° CODE-RPM outlet  
and Parallel Shaft Gearbox  
AKP121111D

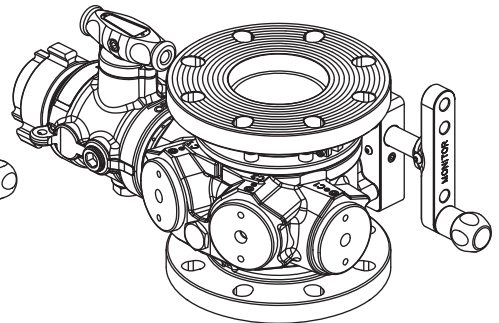

VUM with 4" ANSI 150 outlet  
and 2.5" Straight Valve  
AKM131114D

\*valid for monitor outlets up to 17" (432mm) tall from the VUM outlet. Read section 4.3 for details.

**TASK FORCE TIPS, INC.**  
MADE IN USA • [www.tft.com](http://www.tft.com)

3701 Innovation Way, Valparaiso, IN 46383-9327 USA  
800-348-2686 • 219-462-6161 • Fax 219-464-7155

**▲ DANGER**

**PERSONAL RESPONSIBILITY CODE**

The member companies of FEMSA that provide emergency response equipment and services want responders to know and understand the following:

1. Firefighting and Emergency Response are inherently dangerous activities requiring proper training in their hazards and the use of extreme caution at all times.
2. It is your responsibility to read and understand any user's instructions, including purpose and limitations, provided with any piece of equipment you may be called upon to use.
3. It is your responsibility to know that you have been properly trained in Firefighting and /or Emergency Response and in the use, precautions, and care of any equipment you may be called upon to use.
4. It is your responsibility to be in proper physical condition and to maintain the personal skill level required to operate any equipment you may be called upon to use.
5. It is your responsibility to know that your equipment is in operable condition and has been maintained in accordance with the manufacturer's instructions.
6. Failure to follow these guidelines may result in death, burns or other severe injury.







Fire and Emergency Manufacturers and Service Association  
P.O. Box 147, Lynnfield, MA 01940 • [www.FEMSA.org](http://www.FEMSA.org)

# Table Of Contents











1.0 MEANING OF SAFETY SIGNAL WORDS .....	4
2.0 SAFETY.....	4
3.0 GENERAL INFORMATION.....	5
3.1 SPECIFICATIONS .....	5
3.2 CORROSION RESISTANCE .....	5
3.3 USE WITH SALT WATER .....	5
3.4 PARTS IDENTIFICATION AND MODELS .....	6-7
3.5 OPTIONS, DIMENSIONS AND WEIGHTS.....	8
3.5.1 MODEL NUMBERING SEQUENCE .....	8
3.5.2 MAIN VALVE BODY.....	8
3.5.3 VALVE CONTROL OPTIONS .....	9
3.5.4 OPTIONS FOR SIDE B OUTLET TO MONITOR.....	10
3.5.5 AUXILIARY PORT OPTIONS .....	11-12
3.5.6 INTERNAL AUTOMATIC DRAIN VALVE .....	13
4.0 INSTALLATION .....	14
4.1 DIRECTION OF FLOW.....	14
4.2 STRUCTURAL REQUIREMENTS FOR MONITOR MOUNTING.....	14
4.3 MONITOR INSTALLATION.....	14-17
4.4 ELECTRICAL INSTALLATION AND WIRING .....	18
4.4.1 INTERFACE ENCLOSE MOUNTING .....	18
4.5 ELECTRICAL TESTING .....	18
4.6 INPUT SIGNAL CONFIGURATION .....	19
4.7 VALVE POSITION FEEDBACK RELAYS .....	19
4.8 AUX BUTTON OPERATION .....	20
4.9 CHANGING CRANK HANDLE OR HANDWHEEL TO RIGHT SIDE – MANUAL MODELS.....	20
4.10 CHANGING HANDWHEEL TO RIGHT SIDE – RC MODELS.....	21
4.11 SHAFT EXTENSION FOR HANDWHEEL OR CRANK HANDLE.....	21
4.12 CHANGING OFFSET OF COMPACT CRANK HANDLE.....	21
4.13 ALUMINUM HANDLE KITS FOR 2.5" GATED ELBOWS AND STRAIGHT HYDRANT VALVES .....	22
4.14 RECONFIGURING AUXILIARY PORTS.....	22
5.0 USE .....	22
5.1 VALVE POSITION INDICATOR .....	22
5.2 ELECTRIC REMOTE CONTROL - MANUAL OVERRIDE.....	22
5.3 ELECTRIC REMOTE CONTROL OPERATION .....	23
5.4 AUTOMATIC WATER DRAIN VALVE .....	24
5.5 PRESSURE RELIEF VALVE.....	25
6.0 DRAWINGS AND PARTS LISTS.....	26-31
7.0 TROUBLE SHOOTING .....	32
8.0 MAINTENANCE AND REPAIRS .....	32
8.1 WORM DRIVE GEARBOX CRANKSHAFT OVERRIDE AND REPLACEMENT .....	32
8.2 VALVE SEAT REPLACEMENT .....	33
9.0 PRESSURE LOSS.....	34
10.0 TEMPLATES .....	35
11.0 WARRANTY .....	36
12.0 ANSWERS TO YOUR QUESTIONS.....	36

## 1.0 MEANING OF SAFETY SIGNAL WORDS

A safety related message is identified by a safety alert symbol and a signal word to indicate the level of risk involved with a particular hazard. Per ANSI standard Z535.6-2006, the definitions of the four signal words are as follows:

	<b>DANGER</b> indicates a hazardous situation which, if not avoided, will result in death or serious injury.
	<b>WARNING</b> indicates a hazardous situation which, if not avoided, could result in death or serious injury.
	<b>CAUTION</b> indicates a potentially hazardous situation which, if not avoided, may result in minor or moderate injury.
	<b>NOTICE</b> is used to address practices not related to personal injury.

## 2.0 SAFETY

	Do not use AC current to operate the Valve Under Monitor RC. The Valve Under Monitor RC is 12 or 24VDC systems <b>ONLY!</b> Using the wrong power source could cause electrocution, resulting in death or serious injury.
	The electric motor and other components are ignition sources. The Valve Under Monitor RC should be operated only in areas where there is adequate ventilation and no hazard of flammable vapor buildup.
	Injury or death may occur by attempting to use a damaged Valve Under Monitor or Valve Under Monitor RC. Before using the valve inspect it for damage resulting from: <ul style="list-style-type: none"><li>• Exposure to temperatures in excess of 160 degrees F</li><li>• Missing parts, physical abuse</li><li>• Failure to drain valve followed by exposure to freezing conditions. Draining can be performed using the automatic drain valve option. See section 5.4 for instructions.</li></ul>
	This equipment is intended for use by trained personnel for firefighting. Its use for other purposes may involve hazards not addressed by this manual. See appropriate guidance and training to reduce risk of injury.
	Injury or death can result from burst hoses and fittings. Risk can be minimized by the proper care and use of hose and appliances per NFPA 1962. A pressure relief valve is recommended, which must be set to a pressure that does not exceed the specifications of any of the hoses and appliances in use. See sections 5.5 for instructions.
	Maximum operating pressure 300 PSI (21 bar). Do not exceed 300 PSI on either side of the valve.
	Valve must be properly connected. Mismatched or damaged connectors may cause leaking or uncoupling under pressure and could cause injury.
	The Valve Under Monitor RC may be remotely operated. The electric drives are current limited but may still produce enough force to cause injury. Keep hands and fingers away from pinch points on the valve.
	Do not use the manual override hand wheel while the electric controls are in operation. The electric drives produce enough torque to cause injury.
	The Valve Under Monitor RC has current limiting capabilities which stop the motor if an obstruction is encountered. The Valve Under Monitor RC must be installed as instructed using the correct controls and electrical boxes. Failure to do so will result in damage to the electric motor and loss of current limiting controls. This may result in injury.
	Use with salt water is permissible provided the valve is thoroughly cleaned with fresh water after each use. The service life of the valve may be shortened due to the effects of corrosion and is not covered under warranty.

### 3.0 GENERAL INFORMATION

The Valve Under Monitor (VUM) is a lightweight, low friction-loss valve and manifold for installation directly beneath monitors on ladders and platforms. The VUM combines the robust valve mechanism from the TFT Ball Intake Valve with a 4" ANSI 150 inlet and up to four 2.5" outlets. The 2.5" outlets are available with integrated valves, male hose threads or female pipe threads. When paired with a TFT monitor, the monitor flange is omitted for additional weight savings and ease of maintenance.

An electric remote controlled (RC) model allows the valve to be operated from a remote location or from any TFT RC Monitor Operator Station. A typical installation will consist of the VUM RC and a valve interface box. Motor controls are designed to auto sense 12 VDC or 24 VDC operation. The motor control circuit utilizes a position encoder and current limiting to protect the drive train at the ends of travel. Unit is supplied with 2' of cable & plug on VUM RC and valve interface box is supplied with 10' of cable & mating receptacle so installation effort is minimized. Cable has only four conductors (two for power and two for communications) further easing installation effort.

To complete the installation, the installer will need to mount and wire the valve interface box. The power supply for the VUM RC will need to be connected to a protected circuit from the truck's power distribution center. Refer to the specifications section 3.1 for nominal current draw.

### 3.1 SPECIFICATIONS

MODEL	VUM	VUM RC (Remote Control)			
Main Waterway Minimum Diameter (at Valve Seat)	3.65" (93mm)	3.65" (93mm)			
Auxiliary 2.5" Port Minimum Diameter	2.25" (57mm) typical 2.0" (50.8mm) for integrated valves	2.25" (57mm) typical 2.0" (50.8mm) for integrated valves			
Max Pressure	300 psi (21 bar)	300 psi (21 bar)			
Max Flow	2500 gpm @ 130 psi (9500 l/min @ 9 bar) 2000 gpm @ 200 psi (8000 l/min @ 14bar) 1500 gpm @ 300 psi (6000 l/min @ 21 bar)				
Hydrostatic Proof	900 psi (62bar)				
Temperature Rating*	-25° to 135°F (-32° to 57°C)	-25° to 135°F (-32° to 57°C)			
Worm Drive Gearbox reduction	7.5 turns open to closed (30:1)	7.5 turns open to closed (30:1)			
Parallel Shaft Gearbox reduction	8 turns open to closed (32:1)	not applicable			
Opening/Closing Speed	6 sec				
Voltage- Auto Sense	12 or 24 Volt DC				
Motor Current (RC Only)	Nominal*		Limit		
	@ 12 VDC	@ 24 VDC	@ 12 VDC	@ 24 VDC	
	3 amp	1.5 amp	12 amp	6 amp	
Recommended Fuse or Circuit Breaker Size	15 amp @ 12 Volt 7.5 amp @ 24 Volt				
Environmental Rating	All components designed to meet minimum rating of NEMA 4 (IP65)				
*for temperatures below 32°F (0°C), VUM and monitor must be drained after use to avoid damage. See section 2.0 SAFETY and section 5.4 AUTOMATIC WATER DRAIN VALVE for instructions.					

### 3.2 CORROSION RESISTANCE

All aluminum components are hardcoat anodized for corrosion resistance. Cast aluminum valve bodies are powder coated inside and out for additional corrosion resistance. The effects of corrosion can be minimized by good maintenance practice. See section 8.0 for maintenance.



**Do not couple aluminum to brass. Dissimilar metals coupled together can cause galvanic corrosion that can result in damage to the aluminum structure.**

### 3.3 USE WITH SALT WATER

Use with salt water is permissible, provided valve is thoroughly cleaned with fresh water after each use. The service life of the valve may be shortened due to the effects of corrosion and is not covered under warranty.

### 3.4 PARTS IDENTIFICATION AND MODELS

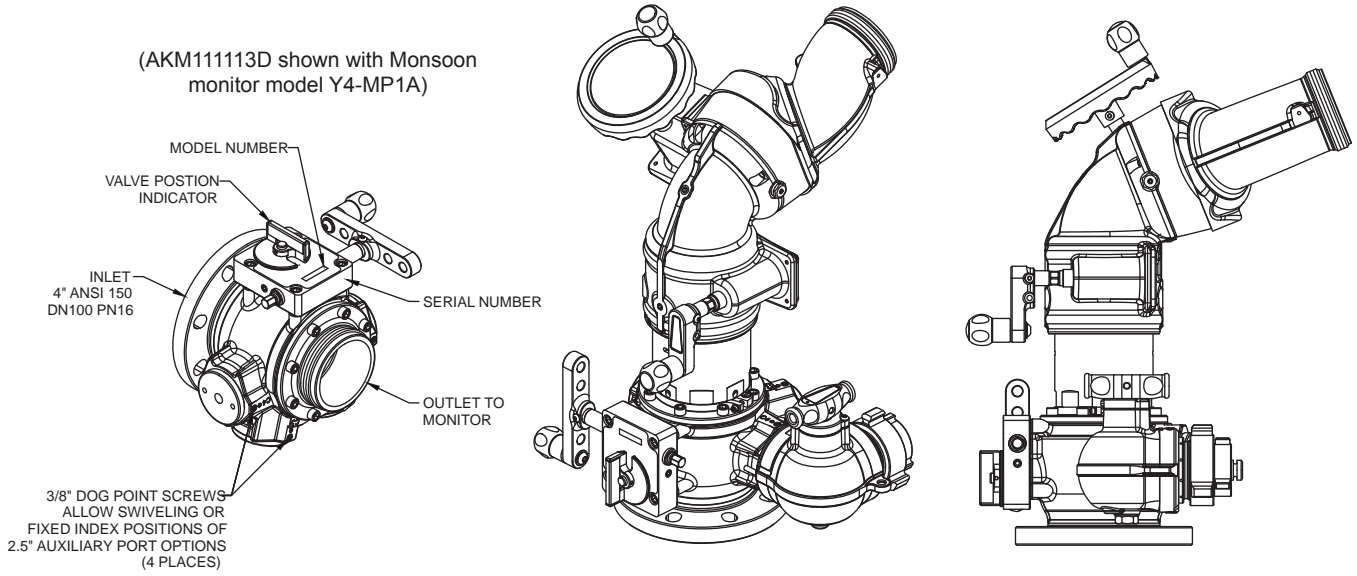

Figure 3.4a  
VUM WITH MANUAL CRANK CONTROL ( WORM DRIVE GEARBOX )

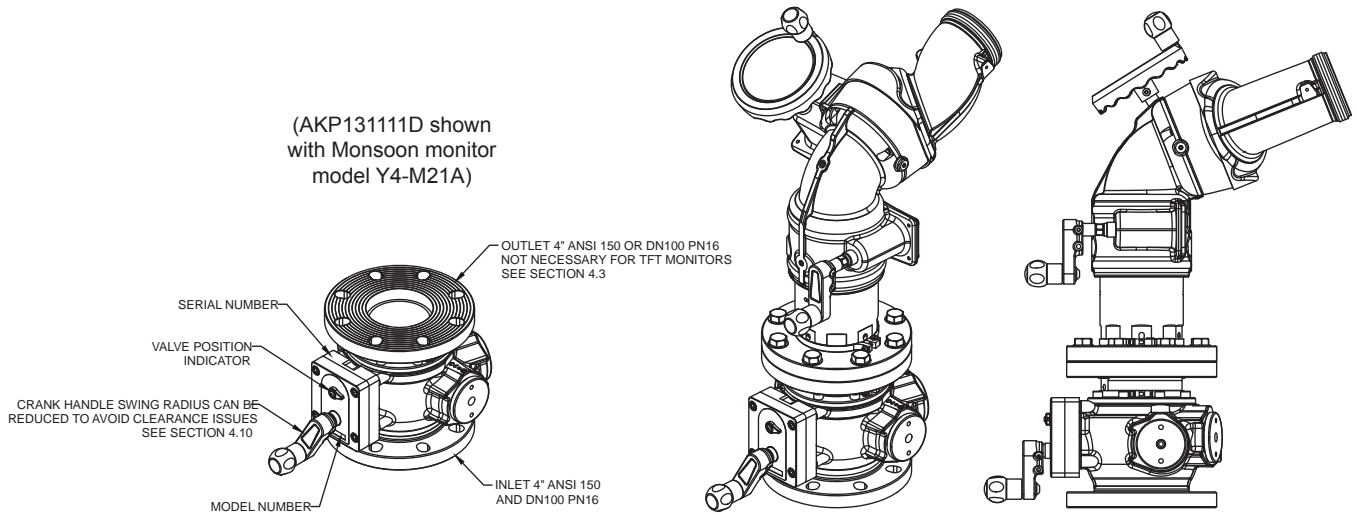

Figure 3.4b  
VUM WITH PARALLEL DRIVE GEARBOX



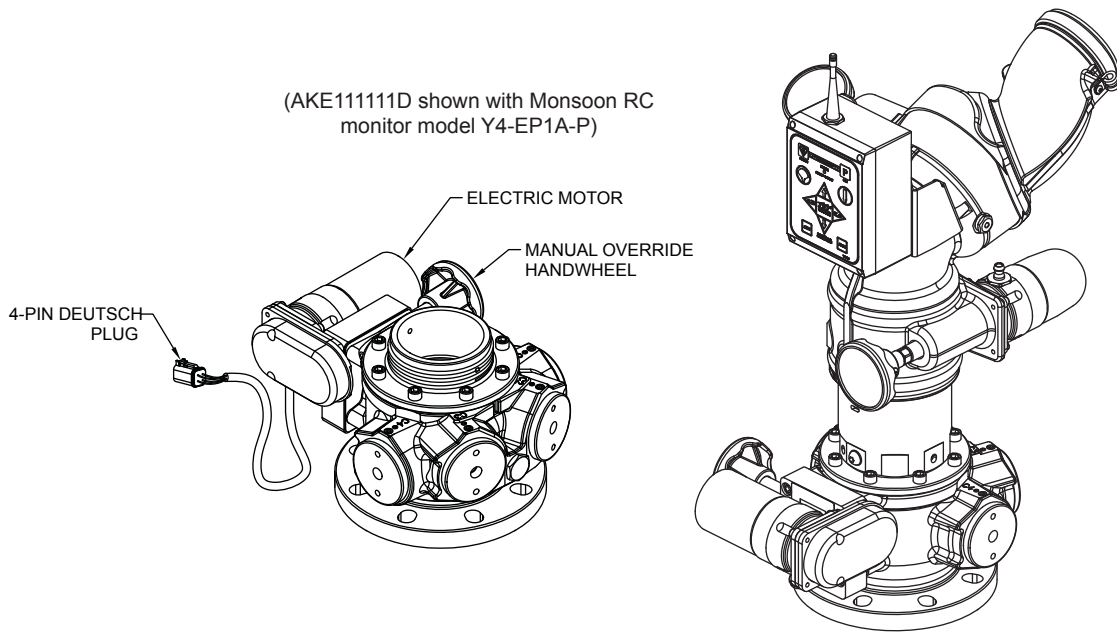

Figure 3.4c  
VUM WITH ELECTRIC REMOTE CONTROL ( VUM RC )

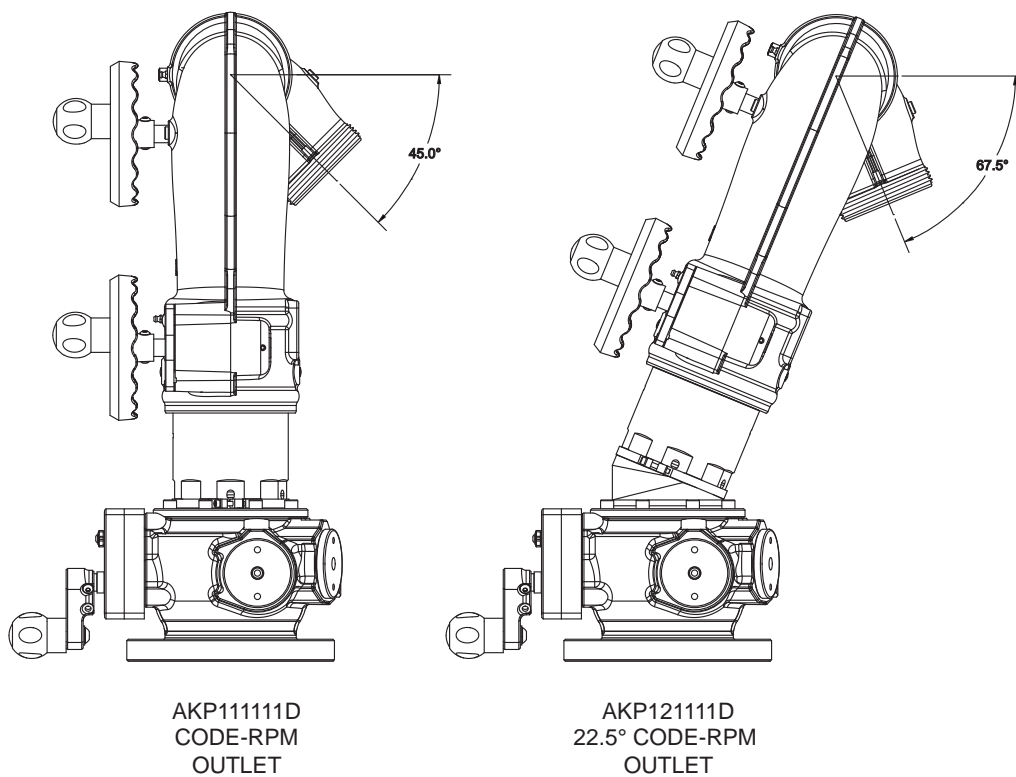

Figure 3.4d  
VUM WITH 22.5° OUTLET  
(shown with Typhoon monitor model Y5-DP1A)

- Angle of monitor outlet is offset by 22.5° below horizontal (45° of travel below horizontal becomes 67.5°).
- Not all auxiliary port options are compatible with the 22.5° outlet, depending on which model monitor is used.
- Please consult TFT Service Department for any questions regarding option compatibility.

### 3.5 OPTIONS, DIMENSIONS AND WEIGHTS

Several options are available for valve control, monitor mounting, and the four auxiliary ports. Each option is described in sections 3.5.2 through 3.5.6. The dimensions and weights of individual options can be added together to calculate the overall size and weight of the VUM with the desired options installed.

#### 3.5.1 MODEL NUMBERING SEQUENCE

Model numbers can be specified by combining 10 characters in the sequence shown below. The unique characters for each component option are presented in sections 3.3.2 through 3.3.6, along with the corresponding weights and dimensions.

Character Position	1	2	3	4	5	6	7	8	9	10
Component	AK (same prefix for all models)		Valve Control	1 RESERVED (same for all models)	SIDE B (monitor)	PORT C1 (auxiliary)	PORT C2 (auxiliary)	PORT C3 (auxiliary)	PORT C4 (auxiliary)	DRAIN IN HALF BALL

Example model #:	AKM132113D	Character Sequence	Weight (lb)
Main Valve Body:	Same for all models	prefix AK same for all models	12.7
Valve Control:	Worm Drive Gearbox	Character "M" in position 3	+ 3.5
Side B (monitor):	4" ANSI 150 / DN 100 PN16 Flange, Straight	Character "3" in position 5	+ 6.5
Port C1 (auxiliary):	Gated Elbow Left-Hand 2.5"NHM w/T-Handle	Character "2" in position 6	+ 6.4
Port C2 (auxiliary):	Blind Plug	Character "1" in position 7	+ 0.8
Port C3 (auxiliary):	Blind Plug	Character "1" in position 8	+ 0.8
Port C4 (auxiliary):	Gated Elbow Right-Hand 2.5"NHM w/T-Handle	Character "3" in position 9	+ 6.4
Drain in Half Ball:	Included	Character "D" in position 10	+ 0.0

**Net Weight:** ..... = **37.1**

#### 3.5.2 MAIN VALVE BODY

The main valve body is shared by all VUM models. It weighs 12.7 lb (5.76 kg), including a stainless steel half ball and all fasteners that are shared by every VUM model. The optional drain in the half ball does not affect the weight of the valve.

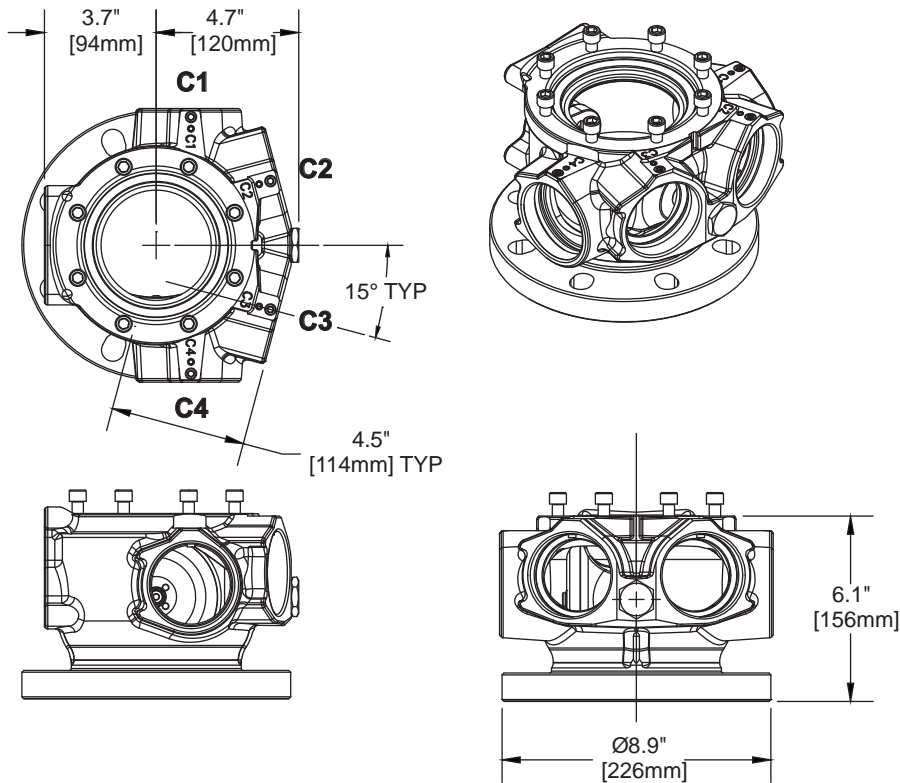



### 3.5.3 VALVE CONTROL OPTIONS

Three valve control options are available: worm drive gearbox, parallel shaft drive gearbox, or electric remote control. These options may be chosen for ease of operation, or to avoid interference with surrounding equipment. The worm drive gearbox (option M) features a crank handle that can be installed on either the left side (default) or right side of the valve. The parallel shaft gearbox (option P) features a crank handle that points away from all of the auxiliary ports, offering the most flexibility in configuring those ports. The electric remote control gearbox (option E) adds a motor to the worm drive gearbox. The included RC Remote Interface Box allows the valve to be operated from a simple hardwired switch or from a CANbus output module. The valve can also be controlled from a remote operator station with valve position feedback, or can be integrated with a wired or wireless TFT monitor control station (all sold separately).

VALVE CONTROL OPTION (character position 3)	CHARACTER	PART NUMBER	WEIGHT (LB)	WEIGHT (KG)
WORM DRIVE GEARBOX	M	A1636	3.5	1.59
PARALLEL DRIVE GEARBOX	P	A1633	3.5	1.59
RC GEARBOX (A1637), GEAR MOTOR (AX1656) and CHAIN DRIVE (AX1690)	E	as noted	7.8	3.54
RC REMOTE INTERFACE BOX		A5920	3.4	1.54

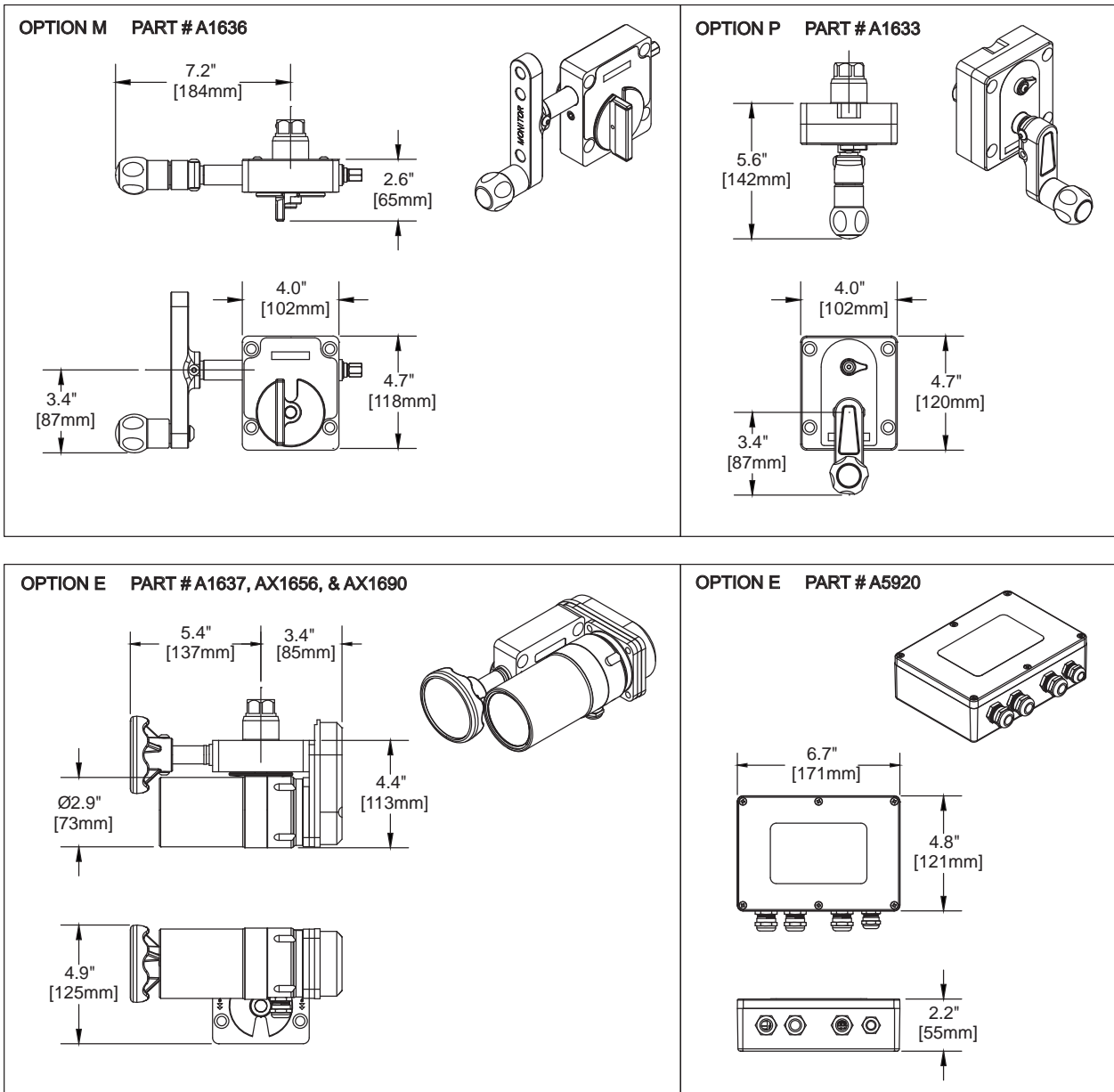

### 3.5.4 OPTIONS FOR SIDE B OUTLET TO MONITOR

The Side B outlet is intended to be connected directly to the inlet of a deluge monitor or nozzle. The industry standard 4" ANSI 150 and DN 100 PN16 bolt patterns are available combined into a single flange option. The other options allow unique capabilities when combined with Task Force Tips monitors, such as reduced size and weight or a secure quick connection.

SIDE B OPTIONS (character position 5)	CHARACTER	PART NUMBER	WEIGHT (LB)	WEIGHT (KG)
CODE-RPM, STRAIGHT	1	A1026	1.8	0.82
CODE-RPM, ANGLED 22.5°	2	A1040	2.8	1.27
4" ANSI 150 / DN 100 PN16 FLANGE, STRAIGHT	3	A1039.1	6.5	2.95
4" ANSI 150 / DN 100 PN16 FLANGE, ANGLED 22.5°	4	A1039.2	7.5	3.40
QUICK CONNECT - 4.5"NHM (for Monsoon, Typhoon, Hurricane & 90° Elbow)	Q	Y4484	2.3	1.04
QUICK CONNECT - 2.5"NHM (for Tornado)	T	Y2432A.1	2.1	0.95
FIXED BASE FOR Tornado Y2-TV1A only	V	Y2414A.1	N/A	N/A
FIXED BASE FOR Tornado RC Y2-EV1A only		Y2416A.1	N/A	N/A

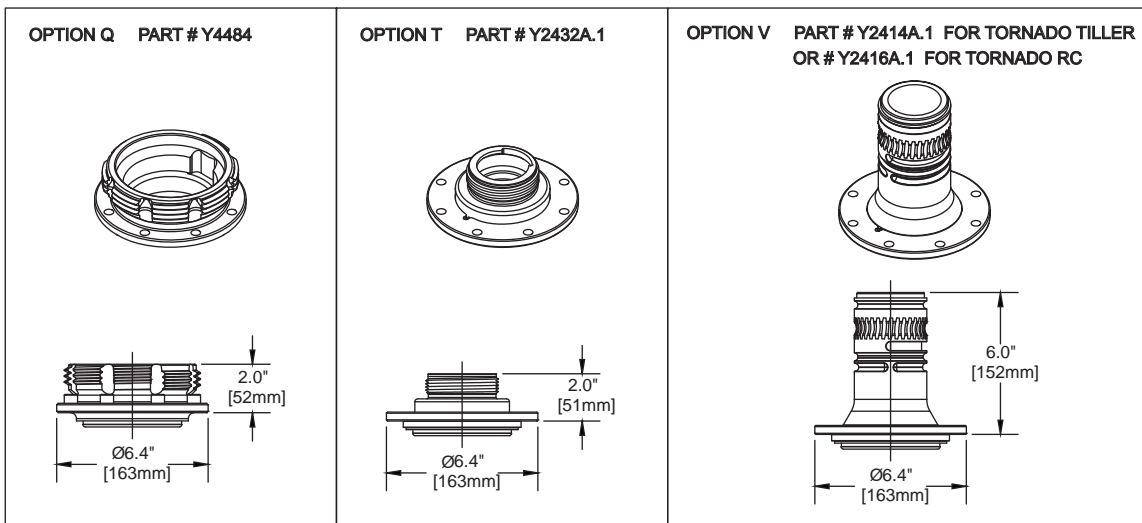
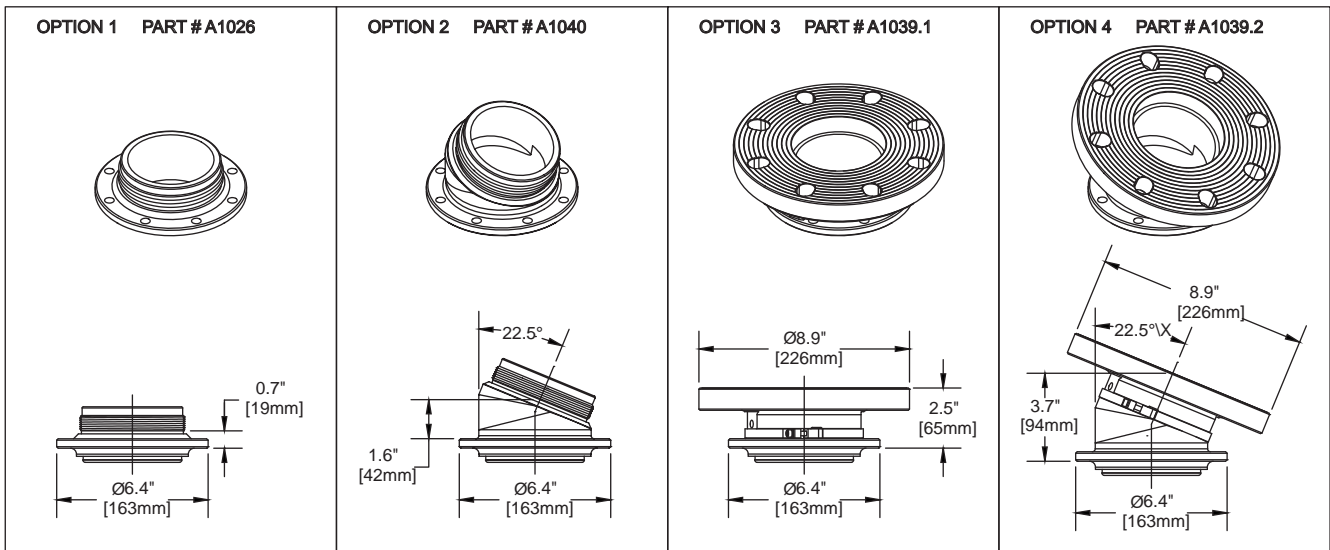

### 3.5.5 AUXILIARY PORT OPTIONS

Four auxiliary ports are included to enhance the capabilities of the VUM by adding hose connections, a pressure relief valve, or an external drain valve. Any of the options shown below may be specified for each of the C1, C2, C3 and C4 ports.

Blind plugs are installed in any unused ports, and each blind plug has 1/4" NPT threads tapped into a blind pilot hole. To install a pressure gauge or other accessory on a blind plug, first drill through the blind pilot hole using a 1/4" drill bit.

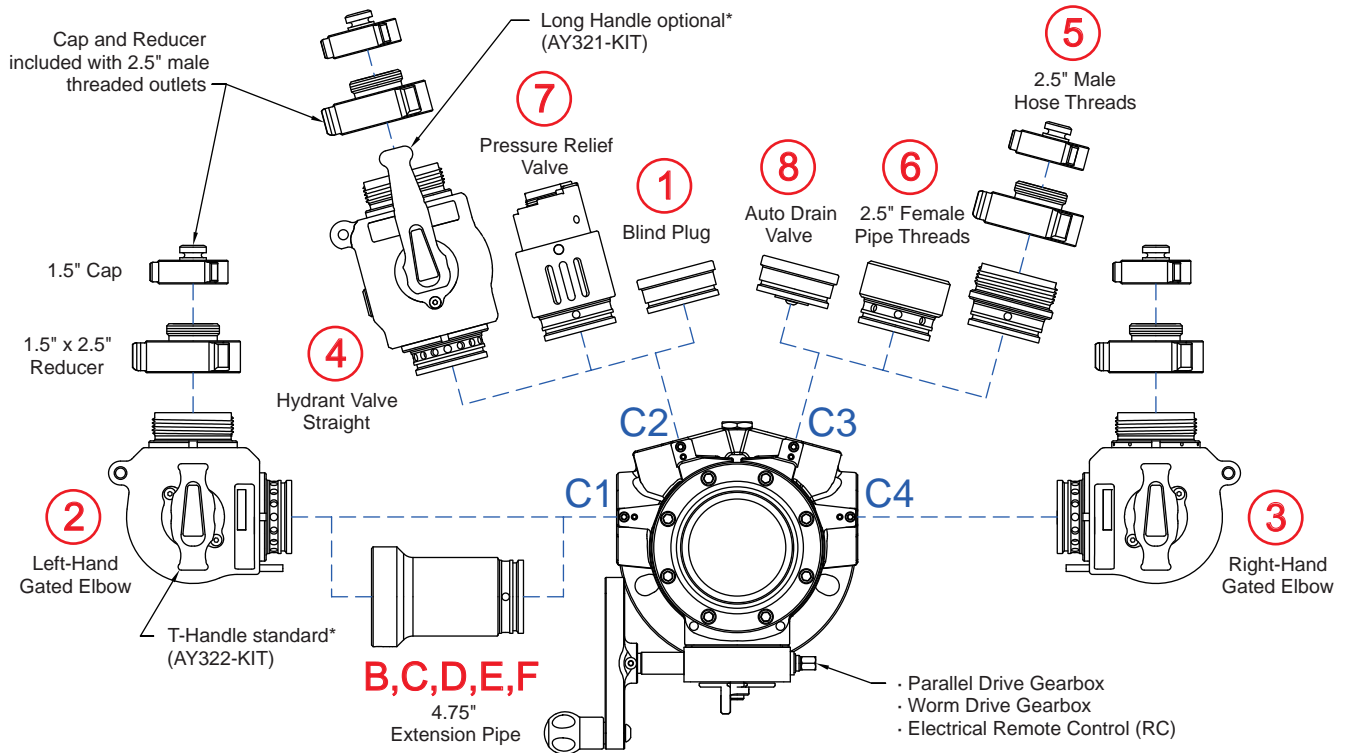

\*T-Handle is not compatible with side B option "Q", so Long Handle is standard for those models instead.

AUX. PORT OPTIONS (character positions 6 thru 9)	CHARACTER	PART NUMBER	WEIGHT (LB)	WEIGHT (KG)
BLIND PLUG	1	A1031.1	0.8	0.36
GATED ELBOW LEFT-HAND 2.5"NHM W/ T-HANDLE (port C1 typical; includes reducer & cap)	2 (B)	AV5LVUM-NJ	6.4	2.90
GATED ELBOW RIGHT-HAND 2.5"NHM W/T-HANDLE (port C4 typical; includes 2.5" X 1.5" reducer & cap)	3 (C)	AV5RVUM-NJ	6.4	2.90
STRAIGHT HYDRANT VALVE 2.5"NHM W/ T-HANDLE (includes 2.5" X 1.5" reducer & cap)	4 (D)	AV5VUM-NJ	6.4	2.90
2.5"NH MALE HOSE THREADS (no valve; includes 2.5" X 1.5" reducer & cap)	5 (E)	A1033NJ.1	1.5	0.68
2.5"NPT FEMALE PIPE THREADS (no valve)	6 (F)	A1035TJ.1	0.5	0.23
PRESSURE RELIEF VALVE (see section 5.5)	7	A1691	1.5	0.73
EXTERNAL AUTO DRAIN VALVE (see section 5.4)	8	A1023.1	0.8	0.36
EXTENSION PIPE 4.75" LONG (add weight to options 2 through 6 above)	B,C,D,E,F	A1032.1	1.8	0.82

**NOTE:** Hose connections on ports C1 and C4 can potentially interfere with the worm drive gearbox. In most cases, worm drive interference issues can be avoided using the dimensions shown in this section and utilizing the hand crank relocation instructions from sections 4.9 through 4.12. There are no such interference issues when a parallel shaft gearbox or electric remote gearbox is installed.

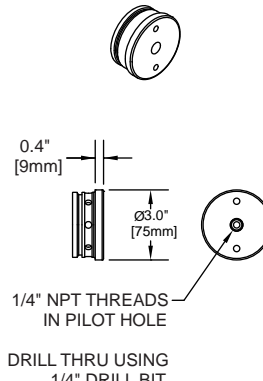
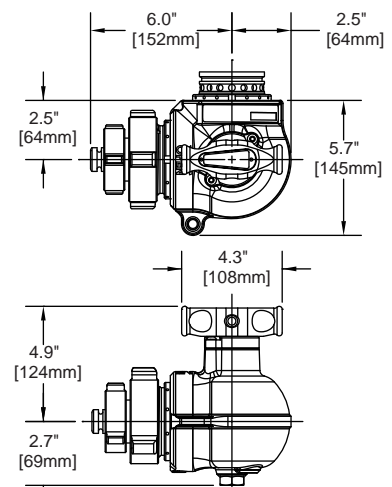
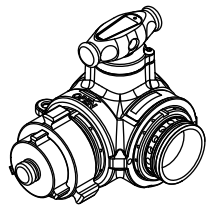
<p><b>OPTION 1 PART # A1031.1</b></p> 	<p><b>OPTION 2 (B) PART # AV5LVUM-NJ</b></p> 	<p><b>OPTION 3 (C) PART # AV5RVUM-NJ</b></p>  <p>All dimensions are identical to option 2</p>
---	--	--

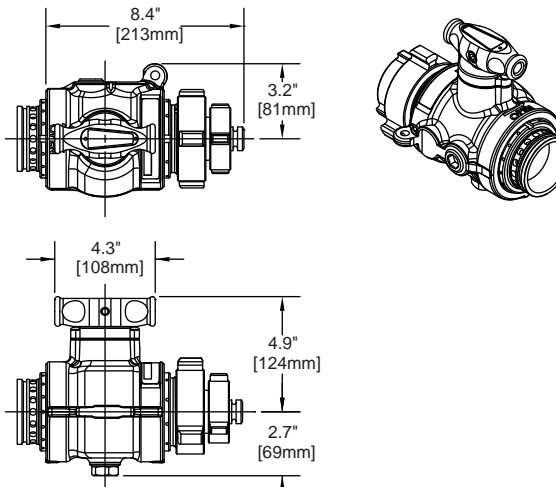
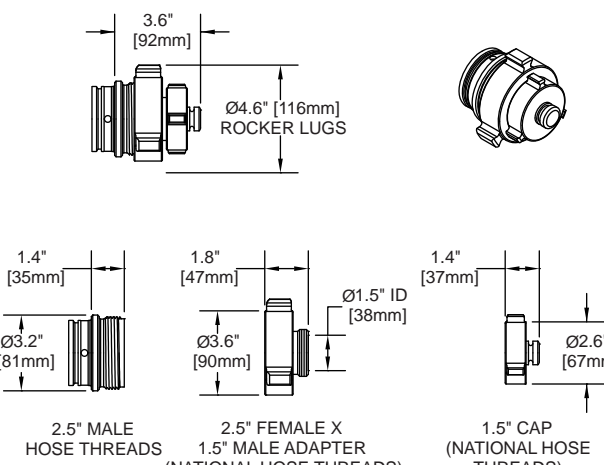
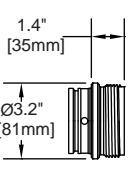
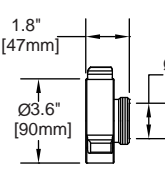
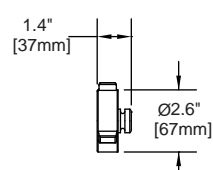
<p><b>OPTION 4 (D) PART # AV5VUM-NJ</b></p> 	<p><b>OPTION 5 (E) PART # A1033NJ.1</b></p>     <p>2.5" MALE HOSE THREADS</p> <p>2.5" FEMALE X 1.5" MALE ADAPTER (NATIONAL HOSE THREADS)</p> <p>1.5" CAP (NATIONAL HOSE THREADS)</p>
--	---

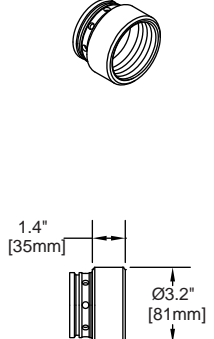
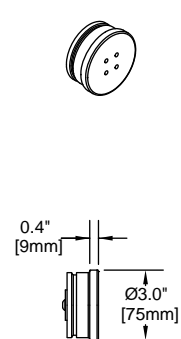
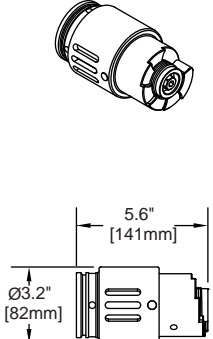
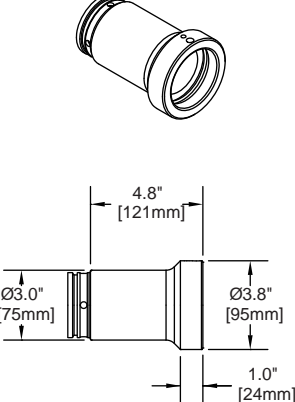
<p><b>OPTION 6 (F) PART # A1035TJ.1</b></p> 	<p><b>OPTION 7 (G) PART # A1023.1</b></p> 	<p><b>OPTION 8 (H) PART # A1691</b></p> 	<p><b>OPTIONS B THRU J PART # A1032.1</b></p> 
---	---	--	---

### 3.5.6 INTERNAL AUTOMATIC DRAIN VALVE

The main ball valve used for monitor shutoff can be specified either with (option D) or without (option Z) an integrated automatic drain valve. The internal automatic drain valve is located in the center of the sealing surface of the half ball. This drain allows an aerial waterway or fixed standpipe to draw atmospheric air to facilitate draining the entire monitor and valve body, even while the half ball is closed. This is particularly beneficial where freezing conditions are a concern. The internal drain valve option does not affect the weight of the assembly. See section 5.4 AUTOMATIC WATER DRAIN VALVE for further details.

AUTO DRAIN IN HALF BALL (character position 10)	CHARACTER	PART NUMBER	WEIGHT (LB)
HALF BALL WITH AUTOMATIC DRAIN	D	A1028S.1	NA - included in main valve
HALF BALL WITHOUT AUTOMATIC DRAIN	Z	A1043S	NA - included in main valve

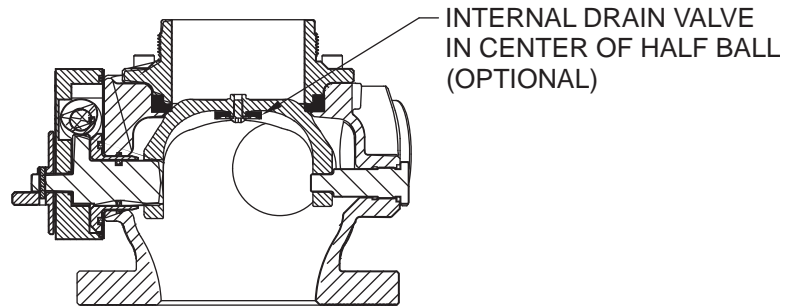

## 4.0 INSTALLATION

### 4.1 DIRECTION OF FLOW

This product is intended to be installed with the main valve seat towards the outlet end as shown in figure 4.1. This allows the auxiliary discharge ports to be used while the main valve (to monitor) is closed. If the direction of flow is reversed, the auxiliary discharge ports will not be active when the main valve is closed and the internal automatic drain valve will not seal (if so equipped).

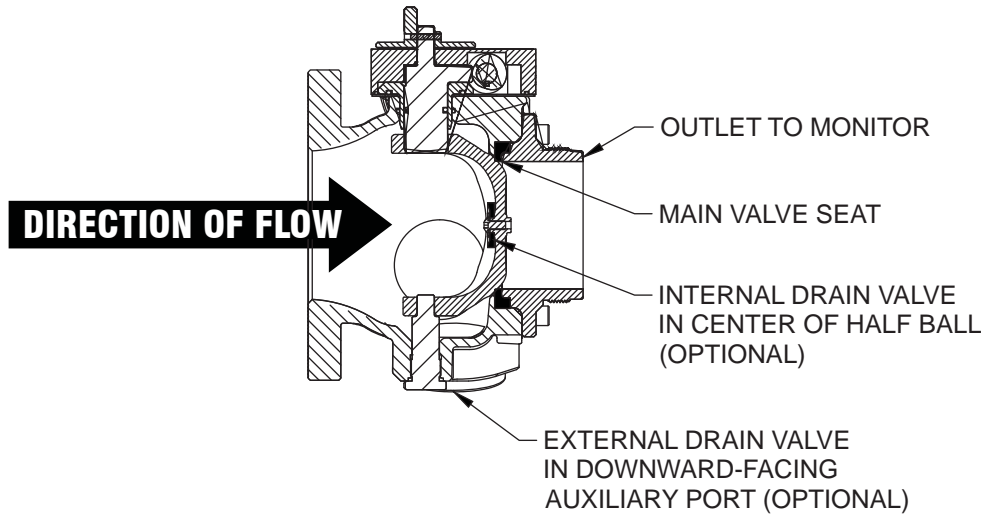

Figure 4.1

### 4.2 STRUCTURAL REQUIREMENTS FOR MONITOR MOUNTING



**WARNING** Injury can result from an inadequately supported monitor. The structure to which the Valve Under Monitor is mounted must be capable of withstanding the internal pressure of the monitor as well as shear and bending forces due to nozzle reaction. Nozzle reaction can be as high as 1500 lbs (680 kg) (2000 gpm at 200 psi, 1500 gpm at 300 psi). Flanges and pipe made from plastic are inadequate for valve mounting and must not be used. This valve is not intended for portable use.

For 4" ANSI 150 or DN100 PN16 flanged connections, the use of flat flanges without raised faces is recommended. Use a ring gasket as defined in ASME 16.21 or ISO 7483. Tighten flange bolts in an alternating sequence as shown in figure 4.2. Tighten to 76-80 ft-lb (100-110 Newton-Meters).

Tighten sequentially each bolt three times.

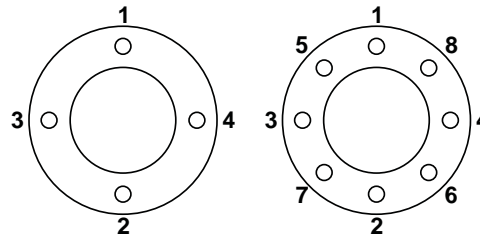

Figure 4.2  
Flange Bolt Tightening Sequence

### 4.3 MONITOR INSTALLATION

The Valve Under Monitor may be equipped with either a CODE-RPM direct connection to TFT monitors or an ANSI / DN flange for use with other devices. Chart 4.3a shows the installed height of each VUM outlet option.

VUM OUTLET TYPE	INSTALLED HEIGHT
CODE-RPM	5.6" net*
22.5° ELBOW CODE-RPM	7.0" net* at center line
4" ANSI 150 FLANGE	8.7" (net = gross)
DN100 PN16 FLANGE	8.6" (net = gross)
* versus 4" ANSI 150 monitor without VUM. Gross height of CODE-RPM is 0.94" taller than net height – see figure 3.3a	

Chart 4.3a



**WARNING** Within the specified operating range, the Valve Under Monitor is designed to withstand nozzle reaction forces from monitors measuring up to 17" (432 mm) from the bottom edge of the monitor inlet to the center line of the monitor outlet. Injury can result from the reaction forces of monitor outlets located more than 17" (432 mm) from the inlet. Figure 4.3b shows examples of acceptable and forbidden monitor installations using the Valve Under Monitor.



**WARNING**

Do not use the Valve Under Monitor with monitor extension pipes such as the Task Force Tips Extend-A-Gun. Injury can result from the reaction forces and overall weight from this combination of products.

FOR MONITOR MODELS NOT SHOWN BELOW, PLEASE CONSULT TFT SERVICE DEPARTMENT.

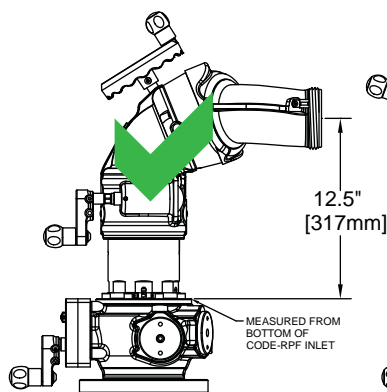

**ACCEPTABLE**  
TFT CODE-RPF AND  
QUICK CONNECT MONITORS  
MEASURING LESS THAN 20"  
**EXAMPLES:**

- MONSOON Y4-MP1A or MQ1A
- MONSOON Y4-TP1A or TQ1A
- MONSOON RC Y4-EP1A or EQ1A
- TYPHOON Y5-DP1A or DQ1A
- TYPHOON Y5-MP1A or MQ1A
- TYPHOON Y5-TP1A or TQ1A
- TYPHOON RC Y5-EP1A-L or EQ1A-L
- TYPHOON RC Y5-EP1A-P or EQ1A-P
- HURRICANE XFIH-DP1A or DQ1A
- HURRICANE XFIH-TP1A or TQ1A
- HURRICANE RC XFIH-EP1A or EQ1A
- TORNADO Y2-T11A or TV1A
- TORNADO RC Y2-E11A or EV1A

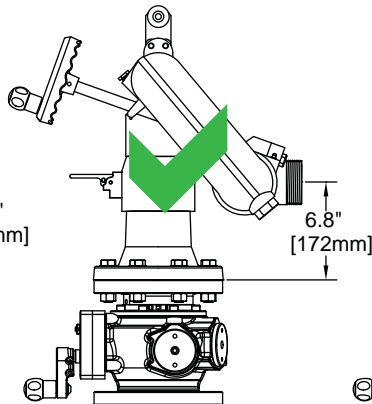

**ACCEPTABLE**  
FLANGED MONITORS  
MEASURING  
LESS THAN 17"  
**EXAMPLES:**

- HURRICANE XFI-FPNJ
- HURRICANE XFIE-FPNJ
- HURRICANE XFIH-D21A\*
- HURRICANE XFIH-T21A\*
- HURRICANE RC XFIH-E21A\*
- MONSOON Y4-M21A \*
- MONSOON Y4-T21A \*
- MONSOON RC Y4-E21A \*

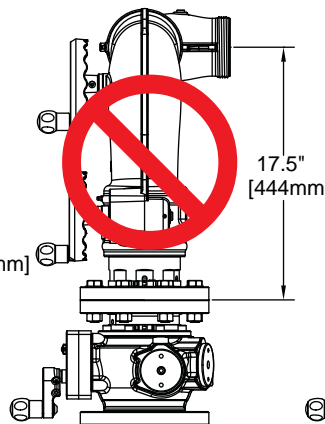

**FORBIDDEN**  
FLANGED MONITORS  
MEASURING  
GREATER THAN 17"  
**EXAMPLES:**

- PROTECTOR Z1121A
- PROTECTOR Z1221A
- TYPHOON Y5-D21A \*
- TYPHOON Y5-M21A \*
- TYPHOON Y5-T21A \*
- TYPHOON RC Y5-E21A-L \*
- TYPHOON RC Y5-E21A-L20 \*
- TYPHOON RC Y5-E21A-L80 \*
- TYPHOON RC Y5-E21A-P \*

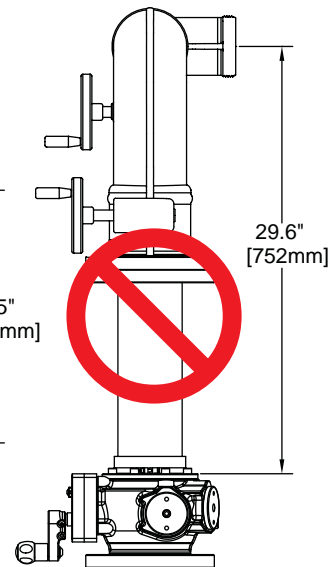

**FORBIDDEN**  
MONITORS ON  
EXTENSION PIPES  
ABOVE THE VUM  
**EXAMPLES:**

- TFT EXTEND-A-GUN
- AKRON® 3406 ELECTRIC RISER
- ELKHART® EXTENDER

**\*FLANGES (4" ANSI 150 OR DN100 PN16) CAN BE REMOVED FROM MOST TFT MONITORS IN ORDER TO USE THE CODE-RPM DIRECT CONNECTION.**

Figure 4.3b  
ACCEPTABLE AND FORBIDDEN MONITOR INSTALLATIONS

**CODE-RPM DIRECT CONNECTION TO TFT MONITOR:**

Direct connection saves approximately 10 lbs (4.5 kg) of weight and 3" (76 mm) of height by omitting flanges from both the VUM outlet and TFT monitor inlet. An additional benefit of this connection is reduced labor for monitor and valve maintenance.

Direct connection consists of CODE-RPM (male threads) on the VUM outlet and CODE-RPF (female threads) on the monitor Base with an o-ring seal. Two different methods of rotational locking between the monitor Base and the VUM outlet exist. One method relies on two ¼-28 Button Head Cap Screws, and the other, newer version, uses a two piece Clamp that is held together with #10 Cap Screws and Cylindrical nuts. The rotational locking method employed can be identified by the presence or absence of two threaded cross-holes, 180 degrees apart in the threaded portion of the VUM outlet, where the monitor Base screws onto the VUM. If ¼-28 Screws are needed, there will be ¼-28 threaded cross-holes in the threaded portion of the VUM outlet. If Clamps are needed, there will be no ¼-28 threaded cross-holes in the threaded portion of the VUM outlet. Once the necessary rotational locking method is determined, install the monitor using one of the following procedures.

### 1/4-28 Button Head Cap Screw Rotational Lock Installation Instructions (with tapped holes, refer to figure 4.3c)

1. Verify that the threaded cross holes on the Side B Outlet Adapter will allow the desired orientation of the Straight Ahead Reference Mark when aligned with one of the pairs of slots on the monitor inlet base. If alignment is acceptable, proceed to step 2.

If alignment is not acceptable, Side B Outlet Adapter may be rotated in 45° increments as described below. When combined with the multiple slot orientations on the monitor inlet, the monitor may be oriented at any 22.5° interval with respect to the VUM bolt hole pattern. To rotate the Side B Outlet Adapter:

- Remove eight 3/8-16 socket head cap screws. Pull the Outlet Adapter away from the Valve Body and Valve Seat, taking care to avoid damage to any sealing surfaces or threads.
  - Orient the Side B Outlet Adapter as desired, then press outlet firmly against Valve Body and Valve Seat.
  - Apply Loctite #242 (blue) compound to 3/8-16 screws and tighten to 180 to 200 in-lb (15 to 17 ft-lb) using the alternating sequence shown in figure 4.2.
2. Screw monitor onto VUM until threaded joint bottoms out.
    - Do not use pipe sealant or Loctite on the inlet base threads. These threads are sealed with an o-ring. Use of thread locking compounds will make removal difficult.
  3. Unscrew monitor slightly until the Straight Ahead Reference Mark is facing the desired orientation.
    - Adjust the rotation as needed to align a pair of slots on the monitor inlet base with the threaded cross holes in the Side B Outlet Adapter.
    - It is acceptable for the monitor to be unscrewed up to one full turn from the bottomed out position.
  4. Install 1/4-28 by 1/2 long socket head cap screws and washers in the two threaded cross holes. Use Loctite #271 (red) on the threads of the socket head cap screws. Allow Loctite to fully cure before applying water pressure.



**Applying greater than 200 in-lbs(17 ft-lbs) torque to Outlet Adapter screws may damage the valve body. Injury could result from use after damaging the valve body.**

### MOUNTING A MONITOR WITH 4" ANSI 150 or DN100 PN 16 FLANGE with 1/4-28 tapped holes:

1. Verify that the bolt pattern of the VUM outlet flange will allow the desired orientation of the monitor. If alignment is acceptable, proceed to step 2. If alignment is not acceptable, the flange may be rotated 22.5° degrees:
  - Remove 1/4-28 x 1/2 long socket head cap screws and washers from cross holes below outlet flange.
  - Adjust rotation of outlet flange until threaded cross holes are aligned in alternate position.
  - Replace 1/4-28 x 1/2 long socket head cap screws and washers. Use Loctite #271 (red) on the threads of the socket head cap screws. Allow Loctite to fully cure before applying water pressure.
2. Install Monitor onto VUM outlet flange using instructions from section 4.2.

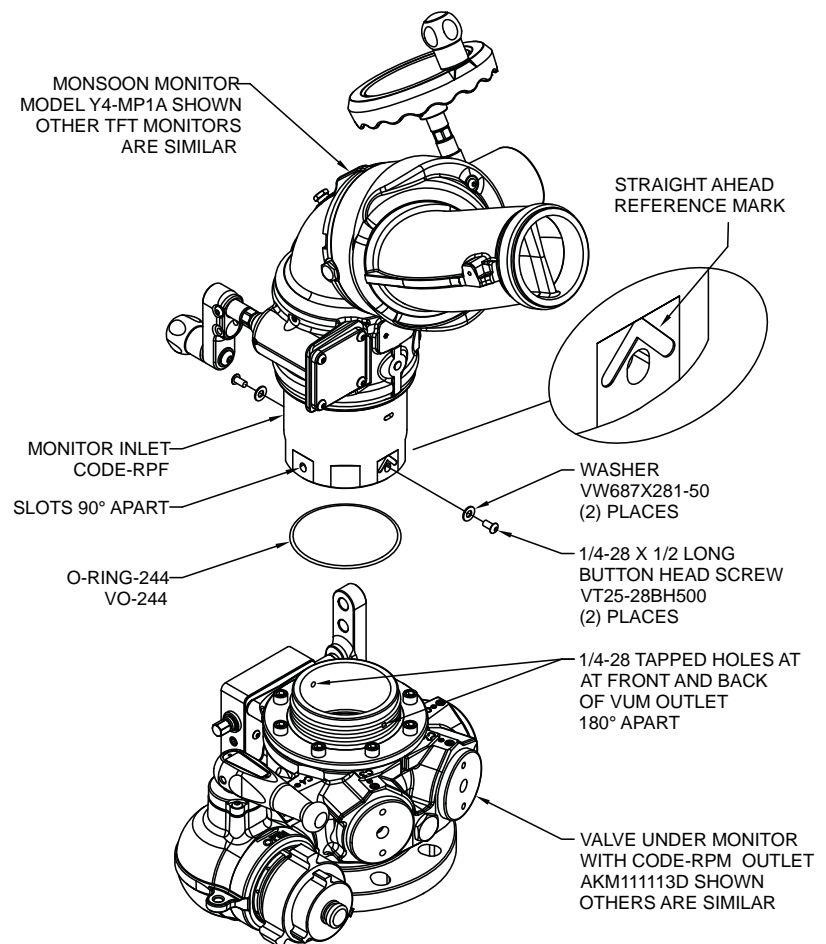

Figure 4.3c  
CODE-RPM DIRECT CONNECTION  
with 1/4-28 tapped holes

## TWO PIECE CLAMP ROTATIONAL LOCK INSTRUCTIONS (without tapped holes, refer to figure 4.3d):

1. Apply blue Loctite to threads of (2) Cylinder Nuts. Assemble Monitor Base Clamp as shown in figure 4.3d and place loosely over Side B Outlet adapter in an orientation that will allow access to the screw heads of the Clamp. Screw monitor onto VUM until threaded joint bottoms out.
  - **CAUTION:** Make sure the Clamps are not tight enough to prevent the monitor Base from bottoming out. The monitor will leak if it does not bottom out in this step.
  - Do not use pipe dope or Loctite on the monitor base threads. These threads are sealed with an O-ring. The use of thread locking compounds will make removal difficult.
2. Unscrew monitor until the "Straight Ahead Reference Mark" is facing the desired direction.
  - Monitor may be unscrewed up to one full turn from the bottomed out position.
  - **CAUTION:** Monitor will leak if unthreaded more than one full rotation from bottomed-out condition.
3. Ensure that Clamp assembly does not interfere with RC monitor Power/Com Cable (if applicable).
4. Tighten each Screw gradually until both are finger tight with approximately equal spacing between opposite ends of Clamps.
5. Carefully tighten each Screw one additional turn using a 5/32 hex wrench by alternating to the opposite Screw in half turn increments. **CAUTION:** Over tightening the Screws will damage Screws and Clamps.

## MOUNTING A MONITOR WITH 4" ANSI 150 or DN100 PN 16 FLANGE (new version with clamps):

1. Verify that the bolt pattern of the VUM outlet flange will allow the desired orientation of the monitor. If alignment is acceptable, proceed to step 2. If alignment is not acceptable, the flange may be rotated using the following steps.
  - Slightly loosen two Screws on Clamps until the outlet flange is able to rotate.
  - Rotate outlet flange as desired.
  - Tighten each Screw gradually until both are finger tight with approximately equal spacing between opposite ends of Clamps.
  - Carefully tighten each Screw one additional turn using a 5/32 hex wrench by alternating to the opposite Screw in half turn increments. **CAUTION:** Over tightening the Screws will damage Screws and Clamps.
2. Install Monitor onto VUM outlet flange using instructions from section 4.2.

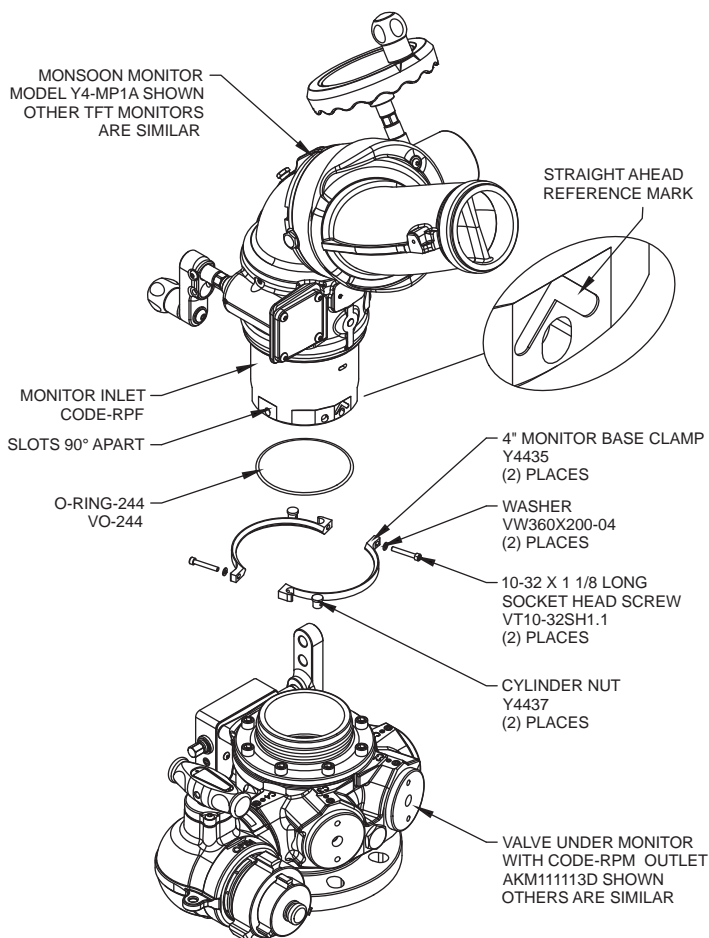

Figure 4.3d  
CODE-RPM DIRECT CONNECTION WITH TWO PIECE CLAMPS

## 4.4 ELECTRIC INSTALLATION AND WIRING

Red (+) and black (-) wires of the Valve Interface Box must be connected to a 12 or 24 VDC protected circuit from the truck's power distribution center. To control the valve from a TFT RC monitor operator station, the valve's Blue and White communication wires must be connected to the monitor's blue and white wires as described in LIY-500 RC MONITOR ELECTRICAL CONTROLS SUPPLIMENT, section 2.0. Figure 4.4 shows the RC VUM typical interface box connections.

### TYPICAL INTERFACE BOX CONNECTIONS

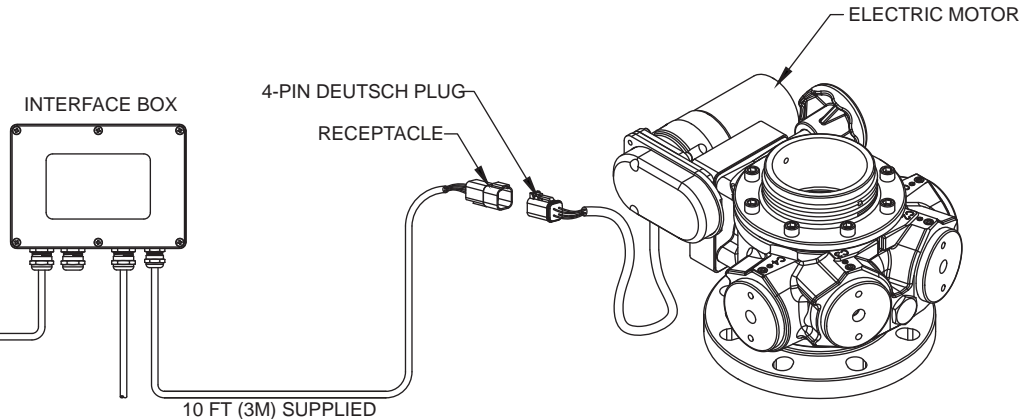
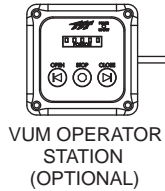
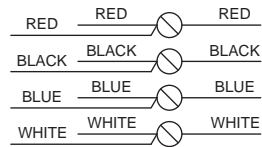

Figure 4.4

### NOTICE

Valve control motor may fail to operate if the voltage drop in the cable is excessive. To avoid this situation, do not lengthen the factory supplied receptacle cable. Power cable selection is critical. Voltage supplied to valve motor board should not fall below 10 volts while valve is in operation.

### NOTICE

In applications where the only valve control will be from a TFT operator station and no feedback relays are required, it is acceptable to install the RC VUM without the valve interface box. The 4-conductor cable with receptacle can be removed from the interface box. The installer must make appropriate connections to a protected circuit and the monitor communication wires, as described above, in a protected enclosure.

### NOTICE

Cable is gel filled to prevent moisture wicking into enclosure. Gel is non-hazardous and should be wiped off conductors using a rag.

### 4.4.1 INTERFACE ENCLOSURE MOUNTING

Select enclosure location. Enclosure is designed to be surface mounted and the size is 4 3/4 x 6 3/4 (120mm x 170mm).

Height of enclosure is 2 1/4" (57mm). Refer to figure 4.4.1 for mounting hole dimensions. A full size template is provided in section 10.0

**NOTE:** Two tapped holes are provided externally on the back side of the box for purposes of mounting.

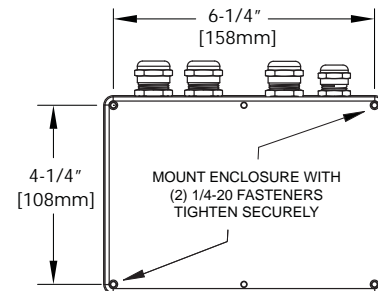

Figure 4.4.1  
Valve Interface Enclosure Mounting Hole Dimensions

## 4.5 ELECTRICAL TESTING

### NOTICE

The TFT Valve Under Monitor RC has built in circuit protection to guard against a circumstance where the unit's movement is blocked before reaching its full travel limits. Without this circuitry the motor would stall, overheat, and could be permanently damaged.

When mechanical installation and electrical connections are complete, perform the following test to verify voltage supply is adequate and the current limiting feature is functioning.

1. Apply power to valve controls.
2. Activate Open or Close inputs until valve reaches stop position. Continue to hold button down.
3. Once movement is stopped, manually turn override knob in opposite direction while input is active. If knob can be turned, then voltage supply is adequate. If knob can't be turned and motor continues to operate, then the current limit was not reached because the voltage supply or wiring is not adequate.

**NOTE:** Override knob will only turn in one direction.

To ensure proper voltage to the Valve Under Monitor RC, the wiring needs to be checked for proper gauge for the installed length of wire, and for proper termination. Also, ensure that the power source supplying the VUM RC and the grounding are adequate (other electrical loads on a shared circuit with the VUM RC may cause a low-voltage situation).

In addition to motor damage, a further consequence of low voltage could be that the valve will not open or close properly or fully.

### SET TRAVEL STOPS

When proper voltage is verified, perform the following to set the full travel limits.

1. Apply power to Valve Controls.
2. Activate CLOSE input until valve is fully closed. Motor must stop by current limit method. If motor continues to operate see proper voltage section above.
3. Activate OPEN input and continue to hold until valve is fully open. Motor must stop by current limit method. If motor continues to operate see proper voltage section above.
4. OPEN/CLOSE input relays will now track valve movement.

### 4.6 INPUTS SIGNAL CONFIGURATION

The Valve Interface box is shipped from the factory configured to accept +12/24 volt DC input signals, but can be field changed to accept ground input signals. To change configuration:

1. Remove lid from box
2. Locate DIP switches on A5830 board
3. Slide DIP switch #4 to the OFF position to select GROUND inputs or slide to the ON position to select VOLTAGE input.
4. Replace lid. Verify rubber seal is clean and undamaged. Verify that no wires are caught between lid and box.

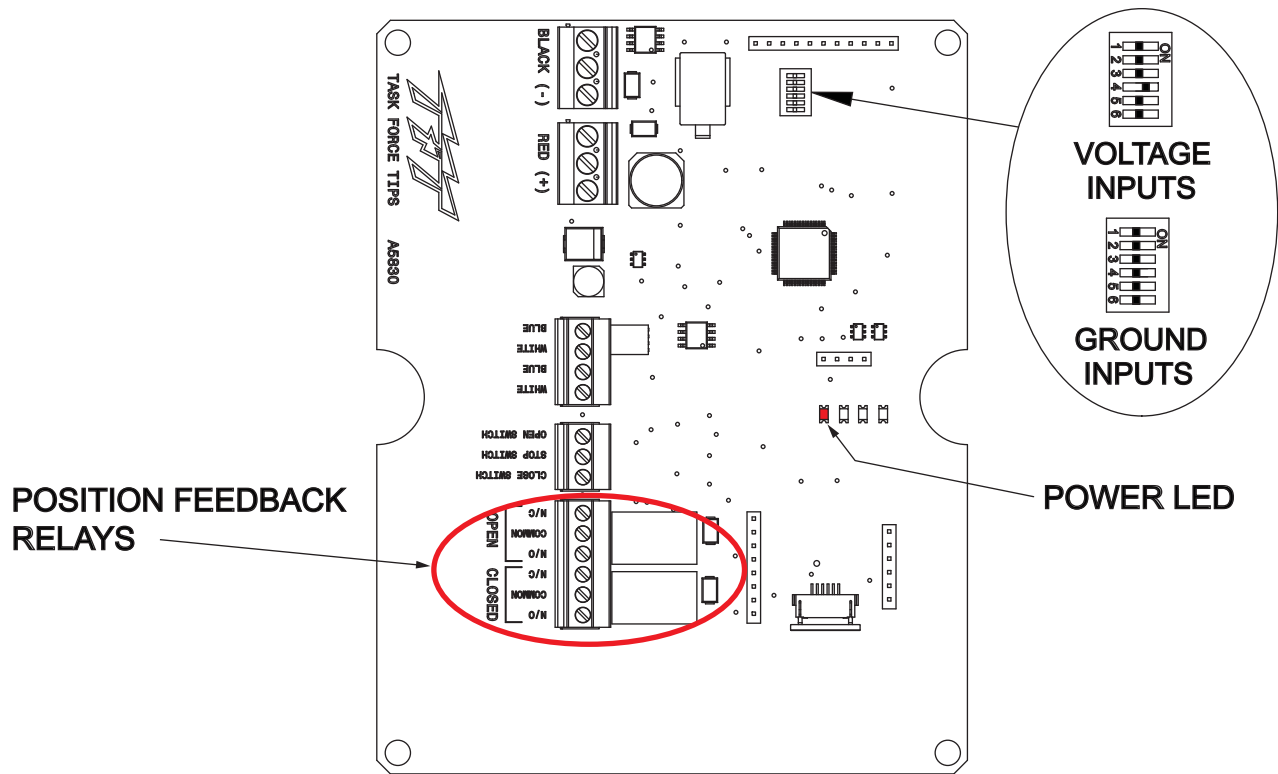

Figure 4.6

### 4.7 VALVE POSITION FEEDBACK RELAYS

The Valve Interface Box provides position feedback for the user to indicate which position the valve is in. The position relays are energized when the valve is in the corresponding position. The contact rating of the relay is 1 amp @ 30VDC for resistive loads and 0.2 amps @ 30 VDC for inductive loads.

The position relays have one dry Form-C contact (common, normally open, normally closed) that can be used. Figure 4.6 shows the terminal blocks available for user wiring.



## 4.8 AUX BUTTON OPERATION

The VUM RC can be operated from any TFT RC Monitor operator station equipped with AUX1/AUX2 buttons. The VUM RC is factory configured to operate from AUX2 button, but can be changed to operate from AUX1 button. To change follow these steps:

1. Turn off power.
2. Remove ring and cap from back of motor. (see figure 6.0d)
3. Slide DIP switch #1 to desired position (see figure 4.8a)
4. Replace cap and ring.
5. Apply power.

Each Valve Under Monitor RC is shipped with several button overlays with adhesive that can be attached to any RC monitor operator station with an AUX button. If additional overlays are needed, contact factory.

Clean operator station surface to remove any oils or residues. Carefully peel off overlay and place on top of AUX button, just inside blue border of button as shown in figure 4.8b

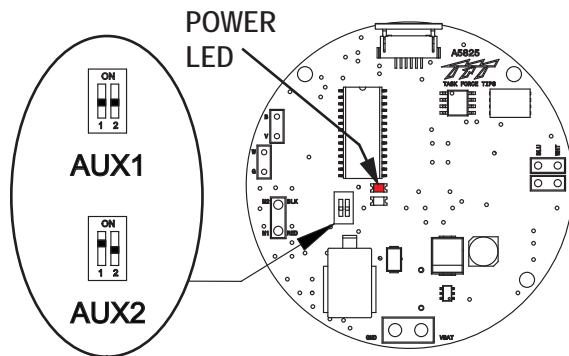

Figure 4.8a

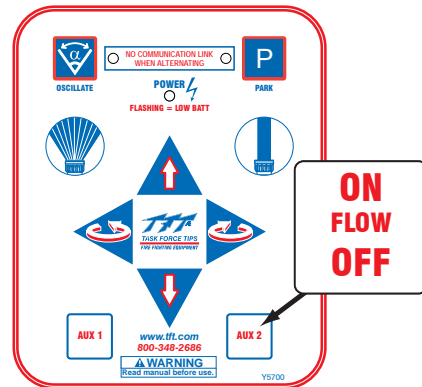

Figure 4.8b - Aux Button Overlay

## 4.9 CHANGING CRANK HANDLE OR HANDWHEEL TO RIGHT SIDE OF VALVE – MANUAL MODELS

Side-mounted crank handles are factory configured on the left hand side of the valve. The crank handle can be switched to the right hand side for convenience or if it interferes with other equipment on the apparatus. For greater clearance, the A1623 crank handle subassembly can be substituted for the A1622 subassembly (see section 4.11). To move the crank handle, refer to the steps and graphic below:

1. Remove the retaining ring (item #1) on the end of the shaft.
2. Pull the shaft (item #2) out of the gear box.
3. As the shaft is withdrawn, grasp the small key (item #3) on the shaft so it does not get lost.
4. Remove and switch the two plastic bushings (items #4 and #5) from the shaft holes in the gearbox. The o-rings (item #6) typically remain in the gearbox, however should be slid back into the gearbox immediately if they slide out with the bushings.
5. Reinstall the bushings on opposite sides of the gearbox. The smaller bushing with the groove on the outside diameter (item #4) must be installed on the same side as the crank handle.
6. Apply a small dab of grease to the key and insert it into slot on the shaft. The purpose of the grease is to prevent the key from falling out of the shaft.
7. Look through the gear box bore to observe the orientations of the notch in the thrust washer (gold color) and the keyway in the worm (silver color) inside the gear box. Slide the shaft into the gearbox with the key oriented the same as the notch in the thrust washer.
8. Rotate the shaft until the key finds both the notch and the keyway, then continue to slide the shaft until the hex flats protrude from the small bushing. The retaining ring groove should be exposed near the hex flats.
9. Reinstall the retaining ring in the square shouldered groove. Do not over expand the retaining ring.

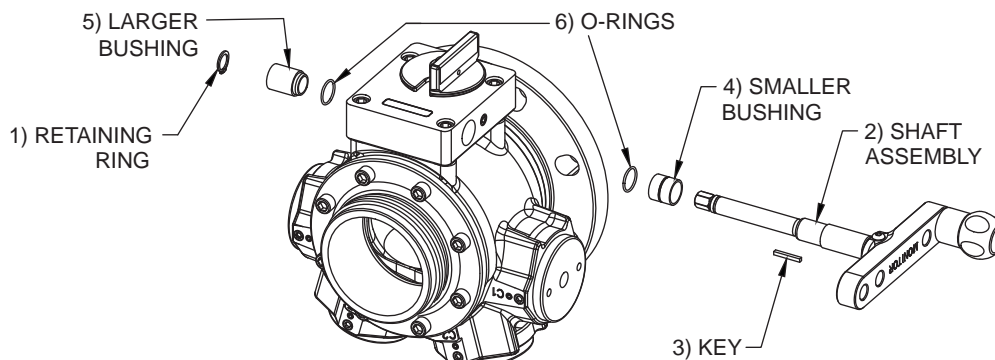

Figure 4.9



## 4.10 CHANGING HANDWHEEL TO RIGHT SIDE – RC MODELS

1. Remove screws and end cover.
2. Slide off both sprockets and chain as one unit.
3. Remove button head screw and lock washer to remove motor unit.
4. Remove set screw from opposite side of gearbox and reinstall it in the hole where the motor unit was mounted. The set screw plugs the hole to keep dirt from entering the gearbox.
5. Remove 4 screws and reposition motor so electric wire points in desired direction.
6. Change hand wheel to other side as in Section 4.9.
7. Reverse steps 1, 2 and 3 to reinstall motor on other side.
8. Reverse polarity (direction) of motor by applying power and holding OPEN & CLOSE buttons or activating OPEN & CLOSE inputs simultaneously for 15 seconds. Cycle power to unit.

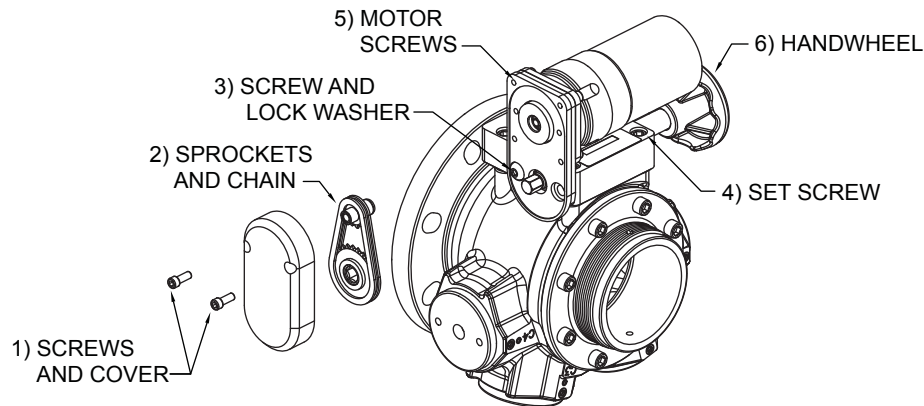

Figure 4.10

## 4.11 SHAFT EXTENSION FOR HANDWHEEL OR CRANK HANDLE

To avoid obstructions or enhance usability, the A1037-KIT shaft extension kit is available for use on both handwheels and crank handles. This kit relocates the handwheel or crank handle 5" further from the gearbox. A1037-KIT adds 0.3 lb (0.14 kg) to the weight of the valve assembly. If further extension is desired, two standard extensions or a custom length extension may be used, with the addition of a support collar to prevent damage to the shaft and gearbox components. Support collars and/or custom length shafts may be constructed based on the dimensions in figure 4.9 below. It is recommended that the support collar constrains the smaller 3/4" end of the extension. The 11/16" hex flats are not necessary for custom shafts.

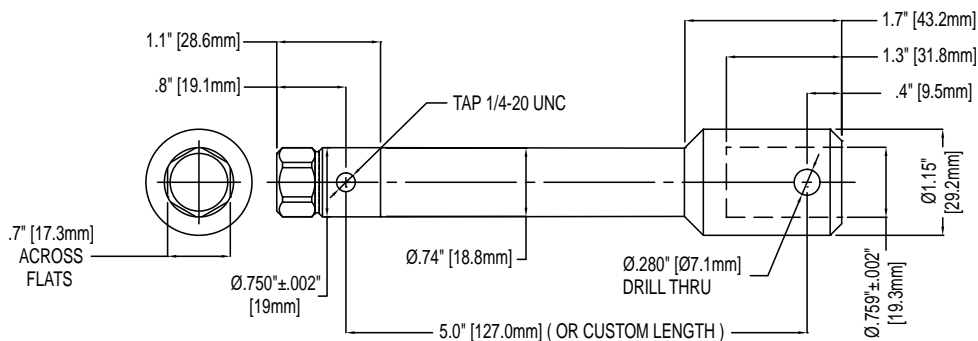

Figure 4.11

## 4.12 CHANGING OFFSET OF COMPACT CRANK HANDLE

A compact crank handle is installed by default on the parallel shaft gearbox. It is also available separately as A1623-KIT, which is compatible with the worm drive gearbox and shaft extension kit. A1623-KIT reduces the assembly weight by 0.21 lb (0.10 kg) versus the standard T-shaped crank handle.

The A1623-KIT compact crank handle includes two offset positions to adjust the swing radius of the crank and knob as shown in figure 4.12. The longer offset position offers reduced effort to operate the valve. The shorter offset position can be used avoid interference with other equipment on the apparatus. To change the offset, remove two 1/4"-20 x 1/2 long button head cap screws from crank. Place crank in desired position. Apply Loctite #242 (blue) to screw threads and replace the screws.

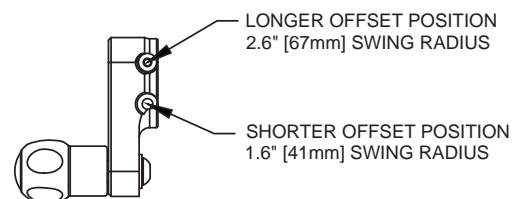

Figure 4.12

### 4.13 ALUMINUM HANDLE KITS FOR 2.5" GATED ELBOWS AND STRAIGHT HYDRANT VALVES

Two aluminum handle options are available for the 2.5" Gated Elbows and Straight Hydrant Valves. Each kit is supplied with a 5/16-18 x 1" long socket head cap screw and a packet of Loctite #242 (blue) to secure the handle.

The AY322-KIT T-Handle minimizes the potential for interference with the monitor and/or apparatus, while still providing sufficient mechanical advantage to open the valve. The T-Handle is installed by default when side B options 1, 2, 3, T or V are specified. AY322-KIT is not compatible with the 4.5" quick connect outlet (option Q).

The AY321-KIT Long Handle provides greater mechanical advantage, however the longer swing radius may result in interference with certain combinations of monitor and/or apparatus. The Long Handle is installed by default when the quick connect outlet (option Q) is specified on side B. The weights in section 3.5.5 include AY322-KIT. AY321-KIT adds 0.2 lb (0.09 kg) versus AY322-KIT.

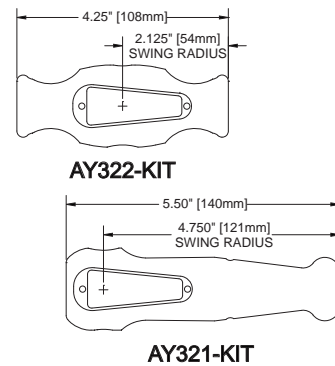
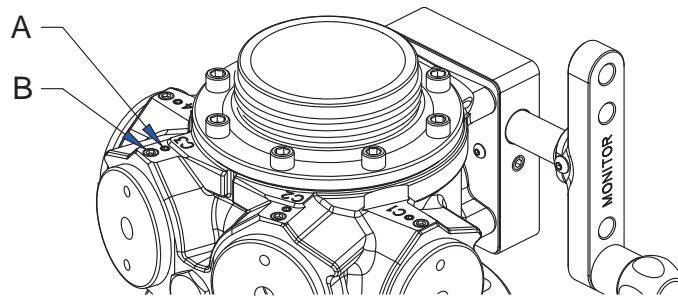

Figure 4.13

### 4.14 RECONFIGURING AUXILIARY PORTS

If re-configuration is necessary, auxiliary port options can be exchanged by removing 46 ball bearings through the 1/4"-28 set screw hole (location A). It is not necessary to dismount the entire VUM if a high-flow vacuum source is available. A 2 hp shop vacuum with a small nozzle is adequate. Loosen the 3/8"-16 dog point set screw (location B). While applying vacuum to (location A), twist the auxiliary device in either direction to help free the ball bearings.



NOTE: Gated elbows are able to pivot, reducing the likelihood and severity of hose kinks. This is accomplished by keeping the 3/8"-16 dog point screw disengaged. When attached directly to ports C1-C4 (options 2 and 3 in section 3.5.5), pivot range is limited to ± 22.5° by a spring pin to prevent interference between the monitor and hoses attached to the gated elbow. When attached to an extension pipe (options B and C in section 3.3.5), no spring pin is installed and 360° rotation is possible. Rotation can be locked to any of 8 indexed positions by engaging the 3/8"-16 dog point set screw (location B in Figure 4.13 above).

## 5.0 USE

### 5.1 VALVE POSITION INDICATOR

To open the valve, turn the handwheel or crank handle until the pointer indicates "OPEN". To close the valve, turn the handwheel or crank handle the opposite way until the pointer indicates "CLOSED".

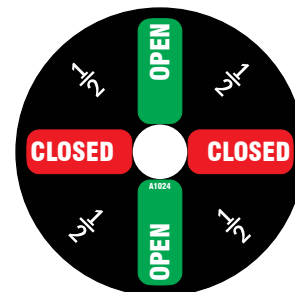

Figure 5.1

### 5.2 ELECTRIC REMOTE CONTROL - MANUAL OVERRIDE

The Valve Under Monitor RC is motor driven but also has an override handwheel for operating the valve manually. The override handwheel may also be used in the event of power failure. If electrical power is supplied to the control panel then the LED valve position display will track the valve's position as the handwheel is moved. If the handwheel is moved while there is no power to the electric controls than the LED valve position display will be in error when the electric power is reconnected. The LED valve position indicator will self correct the first time the valve is cycled under electric control.

If more compactness is desired, the override handwheel may be removed. The drive shaft has a hex so a wrench or socket may be used for manual override. If the manual override handwheel is removed assure that the correct size wrench or socket is available in the event of power failure.

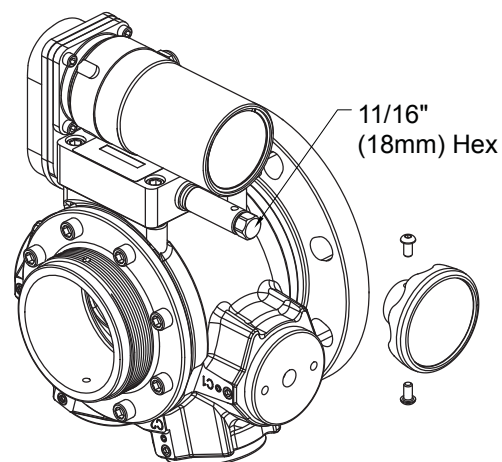

Figure 5.2

## 5.3 ELECTRIC REMOTE CONTROL OPERATION

### Power LED:

LED will be solid green when power is present.

Flashing green LED indicates low voltage.

### Changing Modes (Unit is shipped from factory in the Automatic Mode):

- Activate CLOSE and STOP inputs together for 3 seconds to change to Automatic Mode.
- Activate OPEN and STOP inputs together for 3 seconds to change to Manual Mode.

### Manual Mode – not connected to TFT RC monitor:

- Activating OPEN input will cause valve to open.
- Deactivating OPEN input will cause valve to stop.
- Activating CLOSE input will cause valve to close.
- Deactivating CLOSE input will cause valve to stop.
- STOP input is not applicable in Manual Mode.

### Manual Mode – when connected to TFT RC monitor:

- Activating AUX2 signal or OPEN input will cause valve to open.
- Deactivating AUX2 signal or OPEN input will automatically cause valve to close.

### Automatic Mode – not connected to TFT RC monitor:

- Activating OPEN input (momentarily) will cause valve to travel to full open position.
- Activating CLOSE input (momentarily) will cause valve to travel to full close position.
- Activating STOP input while valve is moving will stop valve.

### Automatic Mode – when connected to TFT RC monitor:

- Activating AUX2 signal will cause full travel. If valve was open, it will move closed and vice-versa.
- Activating AUX2 signal while valve is moving will cause valve to stop momentarily, then reverse direction to full travel.
- Activating OPEN input will cause valve to travel to full open position.
- Activating CLOSE input will cause valve to travel to full close position.
- Activating STOP input while valve is moving will stop valve.

## 5.4 AUTOMATIC WATER DRAIN VALVE

### **▲ WARNING**

**Injury or death may occur by attempting to use a damaged Valve Under Monitor or Valve Under Monitor RC. Before using the valve inspect it for damage resulting from:**

- **Exposure to temperatures in excess of 160 degrees F**
- **Missing parts, physical abuse**
- **Failure to drain valve followed by exposure to freezing conditions.**

The automatic water drain valve allows the monitor and valve body to drain fully after the half ball is closed, thus minimizing susceptibility to damage from corrosion and freezing water. The drain valve is designed to close automatically when pressure exceeds 5 psi. The drain valve is designed to close automatically when pressure exceeds 5 psi. When pressure drops below 5 psi, the drain valve will open. This is dependent on proper assembly, which should be verified visually and functionally prior to fire ground use. Two types of automatic water drain valves are available.

#### INTERNAL DRAIN VALVE

The internal type of drain valve is located within the center of the half ball. It is ideal for installations in which the VUM is installed on a vertical pipe, and allows water from the monitor and valve body to drain into the pipe rather than draining on the ground. See section 3.5.6 for further details.

#### EXTERNAL DRAIN VALVE

The external type of drain valve may be specified in one of the four auxiliary ports. It is ideal for installations in which the VUM is installed in a horizontal or angled pipe. By choosing the appropriate downward facing auxiliary port, the drain valve can discharge towards the ground to remove as much water as possible from the valve body. See section 3.5.5 for further details. In orientations where the monitor shape does not allow full drainage through the nozzle, it may be beneficial to specify both the internal and external drain valve types to avoid pockets of water getting trapped and frozen.

#### USE ON TELESCOPING WATERWAYS (AERIAL APPARATUS)

Specifying either an internal or external automatic drain valve is highly recommended to assist draining and retracting of telescoping waterways. The automatic drain valves are only functional after pressure has been relieved from the waterway and will not serve as a pressure relief valve under any circumstances.

After pressure has been fully relieved to less than 5 psi, the internal drain valve allows water and atmospheric air to backflow through the monitor and VUM to drain the waterway, even if the VUM remains closed. Then, the internal drain valve allows air to vent out to the atmosphere as the waterway is retracted.

If the internal drain valve is not included, then the VUM must be opened prior to draining and retracting the waterway. Otherwise, damage to the waterway may occur if no other atmospheric vent orifice is present.

#### DISABLING THE DRAIN VALVE

When the automatic drain valve function is not desired, it may be disabled. This does not prevent the drain valve from being enabled in the future if desired. Referring to the exploded view figure 6.0a, follow the steps below:

1. Remove the screw and washers from inside of half ball (index 4 & 5).
1. To disable, flip rubber drain valve (index 3) so that raised edge is against flat face of half ball.
2. To enable, flip rubber drain valve (index 3) so that raised edge is away from flat face of half ball.
3. Apply Loctite #242 (blue) to screw threads. Reassemble the washer and screw against the rubber drain valve.

## 5.5 PRESSURE RELIEF VALVE

The optional pressure relief valve can be set to any pressure between 90 and 300 psi. Its function is to protect the pump, aerial waterway, and /or supply hose from excess pressure. Typical performance at various pressures is shown in the graph below. The relief valve may be rotated so its discharge slots face in the desired direction by disengaging and reengaging the 3/8"-16 dog point screw according to the instructions in section 4.14 RECONFIGURING AUXILIARY PORTS.

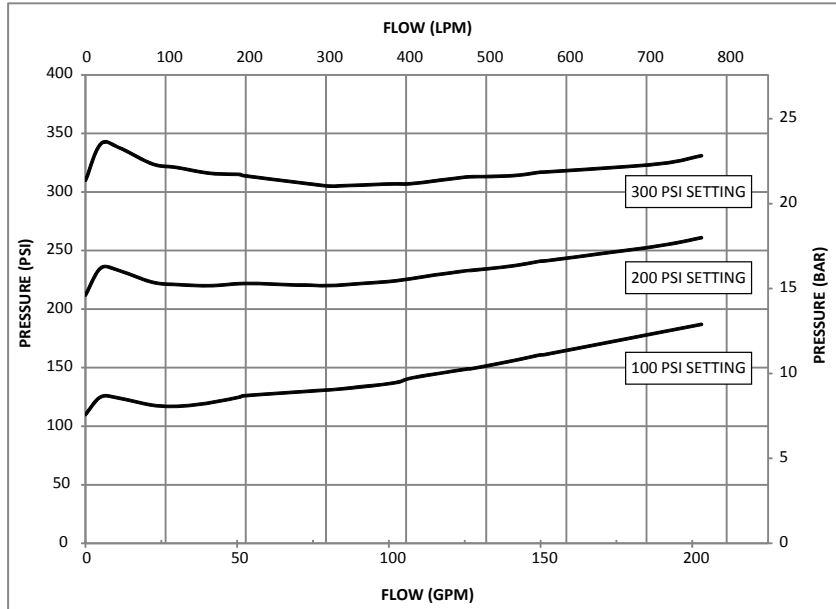

PRESSURE RELIEF VALVE PERFORMANCE

To set the relief valve pressure, turn the adjusting screw on the relief valve housing until the surface of the screw is even with the desired pressure. Do not cap or plug discharge opening. To turn off the Pressure Relief Valve, align the adjusting screw with the OFF position. Placing the Pressure Relief Valve in the OFF position, prevents the valve from venting water. Do not use the OFF position for normal operations. System damage may occur if the Pressure Relief Valve is in the OFF position and the system exceeds its operating limits.

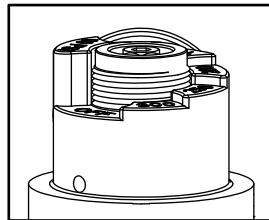
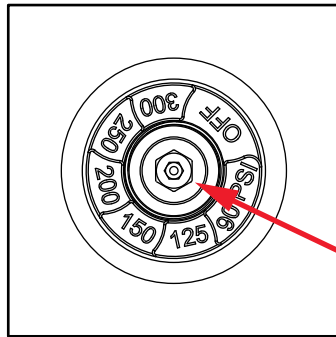

90 PSI

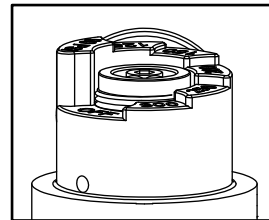

200 PSI

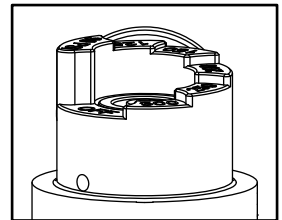

OFF

Use either a 1/4" allen or 9/16" wrench when setting the height of the adjusting screw to the desired pressure.



**WARNING**

Do not leave the pressure relief valve in the OFF position. The pressure relief valve is disabled in the OFF position and offers no protection against over pressurization. The OFF position may be used for controlled pump testing but should not be used for service conditions. Exercise great care to avoid water hammer or other pressure spikes when the pressure relief valve is in the OFF position.



**WARNING**

The Pressure Relief Valve will open to relieve excess pressure but it may not have enough flow capacity to protect against large pressure spikes such as those caused by water hammer. Excess pressure can cause equipment failure and directly or indirectly lead to injury or death. Always operate valves slowly to avoid the risk of water hammer.

## 6.0 DRAWINGS AND PARTS LISTS

Worm Drive Gearbox, Parallel Drive Gearbox  
And RC Motor Assembly shown on following pages

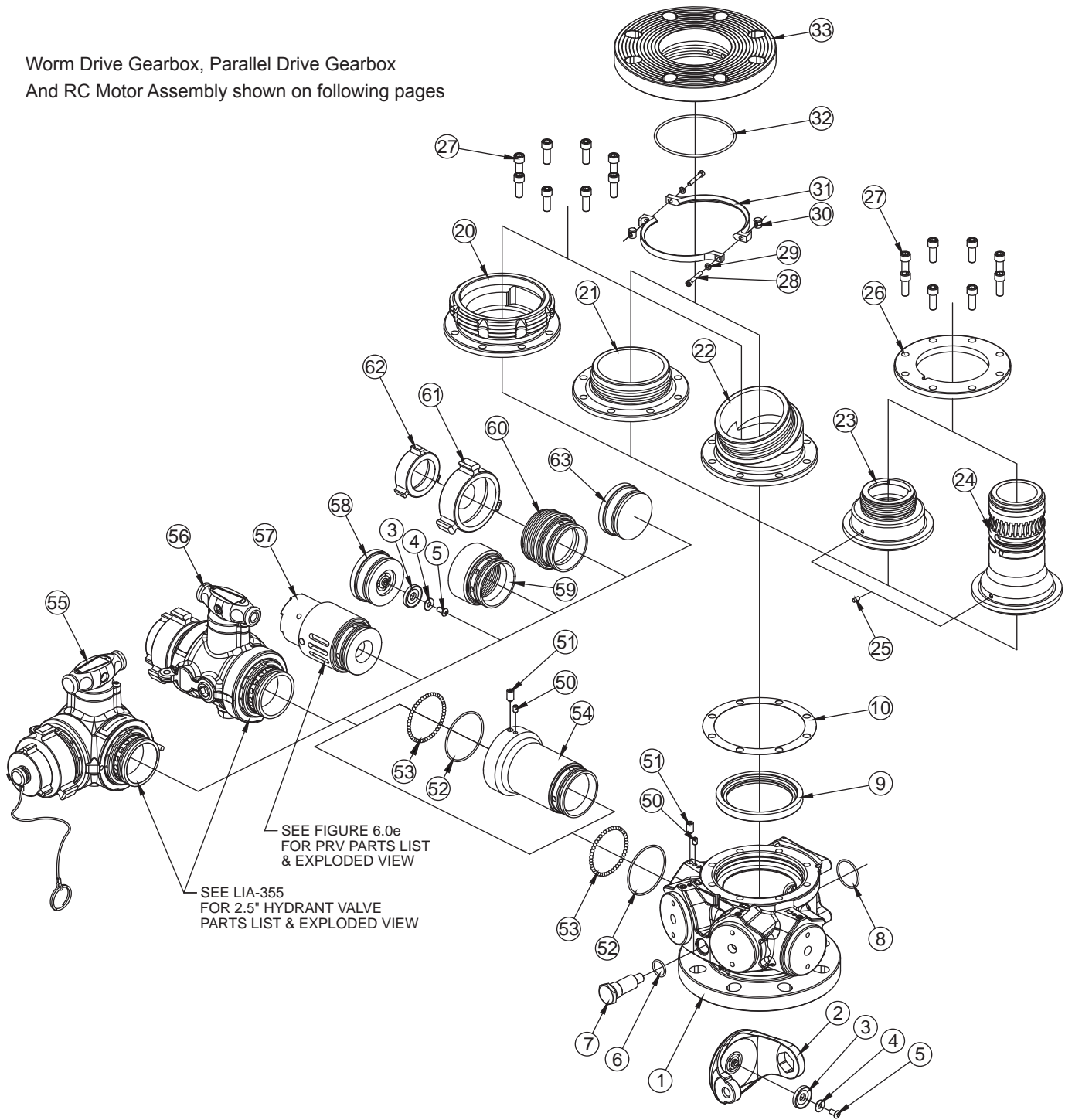

Figure 6.0a  
Exploded View Without Gearbox



## 6.0 DRAWINGS AND PARTS LISTS

### MAIN BODY

INDEX	DESCRIPTION	QTY	ITEM #
1	VUM BODY	1	A1025
2	HALF BALL WITH DRAIN 5.5"DIA STAINLESS	1	A1028S
	HALF BALL NO DRAIN 5.5"DIA STAINLESS	1	A1043S
3	DRAIN VALVE	1	X382
4	SS FLAT WASHER 1/4"	1	VW687X281-50
5	1/4-28 X 1/2 BUTTON HEAD SCREW	1	VT25-28BH500
6	O-RING-117	1	VO-117
7	TRUNNION VUM LOWER	1	A1027
8	O-RING-128	1	VO-128
9	VALVE SEAT 3.65" I.D.	1	A1520
10	VUM OUTLET SHIM	1	A4223

### SIDE B OULET ADAPTER OPTIONS

INDEX	DESCRIPTION	QTY	PART #
20	QUICK CONNECT - VUM X 4.5"NHM	1	Y4484
21	OUTLET VUM CODE-RPM	1	A1026
22	OUTLET VUM 22.5 DEGREE	1	A1040
23	QUICK CONNECT - VUM X 2.5"NHM	1	Y2432A
24	TORNADO TILLER BASE FOR VUM	1	Y2414A
	TORNADO RC BASE FOR VUM		Y2416A
25	3/16 X 3/8 HDP SPIROL PIN	1	VP188X.38HDP
26	FLANGE VUM FOR SMALL MONITORS	1	Y2433
27	3/8-16 X 1 SOCKET HEAD SCREW	8	VT37-16SH1.0
28	10-32 X 1.2 SOCKET HEAD SCREW	2	VT10-32SH1.2
29	WASHER .360 OD X .200 ID X .040 THICK	2	VW360X200-04
30	CYLINDER NUT	2	Y4437
31	4" MONITOR BASE CLAMP	2	Y4435
32	O-RING-244	1	VO-244
33	FLANGE CODE-RPF X 4"ANSI 150	1	A1039

### AUXILIARY PORT OPTIONS (QTY PER PORT)

INDEX	DESCRIPTION	QTY	PART #
50	1/4-28 X 3/8 SOCKET SET SCREW	1	VT25-28SS375
51	3/8-16 X 1/2 SOCKET SET SCRW HALF DOG PT	1	VT37-16DP500
52	O-RING-148	1	VO-148
53	3/16" SS BALL	46	V2120
54	EXTENSION TUBE 4.75" LONG	1	A1032
55	GATED ELBOW LEFT 2.5"NHM - SUBASSEMBLY	1	AV5LVUM-NJ
	GATED ELBOW RIGHT 2.5"NHM - SUBASSEMBLY		AV5RVUM-NJ
56	VALVE STRAIGHT 2.5"NHM - SUBASSEMBLY	1	AV5VUM-NJ
57	PRESSURE RELIEF VALVE SUB 300PSI	1	A1690
58	DRAIN HOUSING HSBGM275	1	A1023
59	OUTLET HSBGM275 X 2.5"NPTF	1	A1035TJ
60	OUTLET HSBGM275 X 2.5"NHM	1	A1033NJ
	OUTLET HSBGM275 X 2.5"NPTM		A1033TJ
61	ADAPTER 2.5"NHF X 1.5"NHM ROCKERLUG	1	P411NJNF
62	BLIND CAP 1.5"NHF W/ 18" LANYARD	1	P412NF
63	PLUG HSBGM275	1	A1031

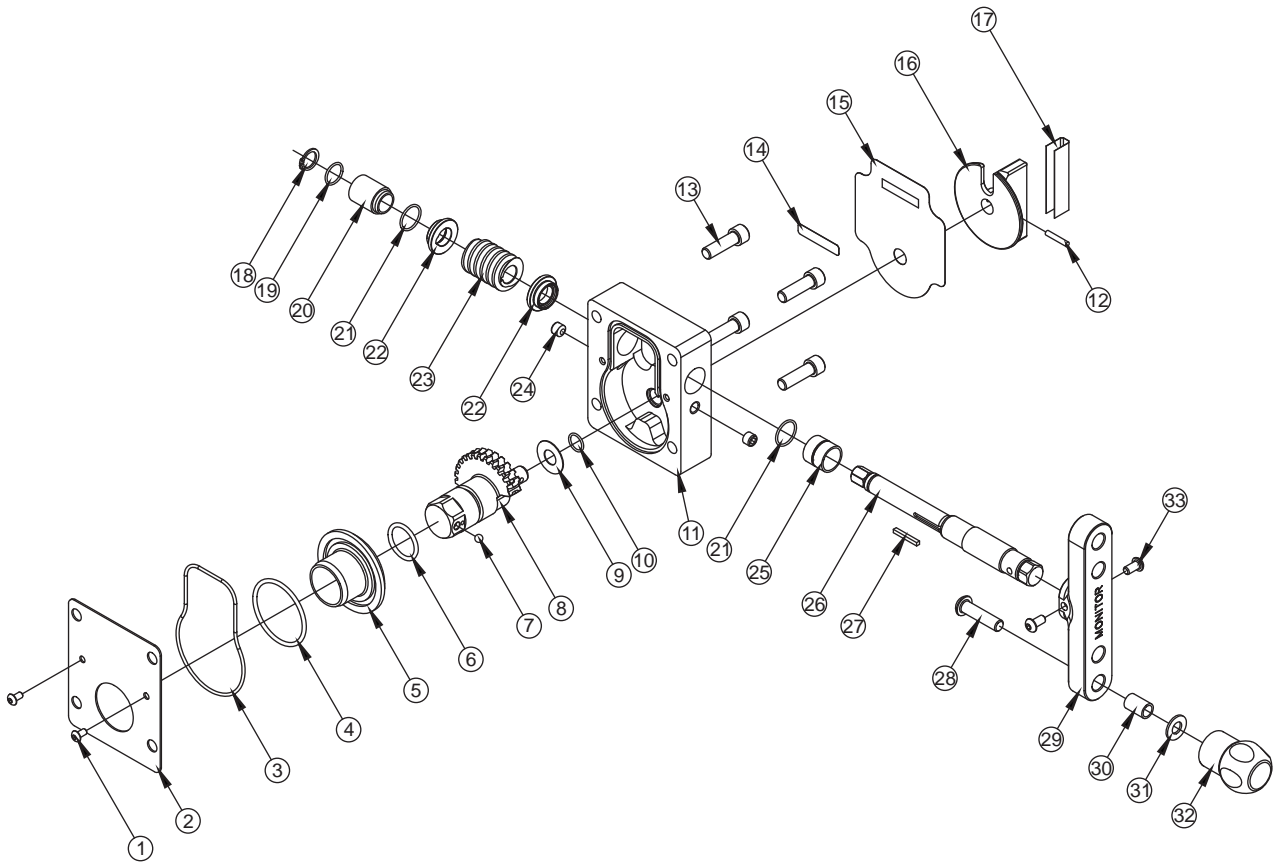

Figure 6.0b  
Exploded View of Worm Drive Gearbox

### WORM DRIVE GEARBOX

INDEX	DESCRIPTION	QTY	ITEM #
1	10-24 X 3/8 BUTTON HEAD SCREW	2	VT10-24BH375
2	GEARBOX COVER	1	A1030
3	O-RING-154	1	VO-154
4	O-RING-226	1	VO-226
5	GEAR SPACER	1	A1511
6	O-RING-214	1	VO-214
7	.243" TORLON BALL	1	VB243TO
8	INTEGRAL WORM GEAR & TRUNNION	1	A1501
9	GEAR THRUST WASHER	1	A1502
10	O-RING-014	1	VO-014
11	GEARBOX	1	A1506
12	5/32 X 7/8 HDP SPIROL PIN	1	V1900
13	3/8-16 X 1 1/4 SOCKET HEAD SCREW	4	VT37-16SH1.2
14	MODEL NUMBER LABEL	1	A1303
15	NAME LABEL: VUM GEARBOX	1	A1024
16	POSITION INDICATOR	1	A1523
17	POSITION INDICATOR LABEL	1	A1524

INDEX	DESCRIPTION	QTY	ITEM #
18	RETAINING RING	1	VR4275
19	O-RING-016	1	VO-016
20	LARGE BUSHING FOR SEALED GEARBOX	1	A1528
21	O-RING-018	2	VO-018
22	WORM THRUST WASHER	2	A1529
23	12 DP WORM - DEGREASED	1	X220
24	3/8-16 X 5/16 SOCKET SET SCREW	2	VT37-16SS312
25	SMALL BUSHING FOR SEALED GEARBOX	1	A1527
26	SHAFT FOR SEALED GEARBOX	1	A1533
27	KEY	1	X225
28	3/8-16 X 1-1/2 BUTTON HEAD SCREW	1	VT37-16BH1.5
29	T-HANDLE CRANK	1	A1534
30	CRANK BUSHING	1	A1547
31	WASHER	1	VW812X406-65
32	KNOB	1	A1512
33	1/4-20 X 1/2 BUTTON HEAD SCREW	2	VT25-20BH500

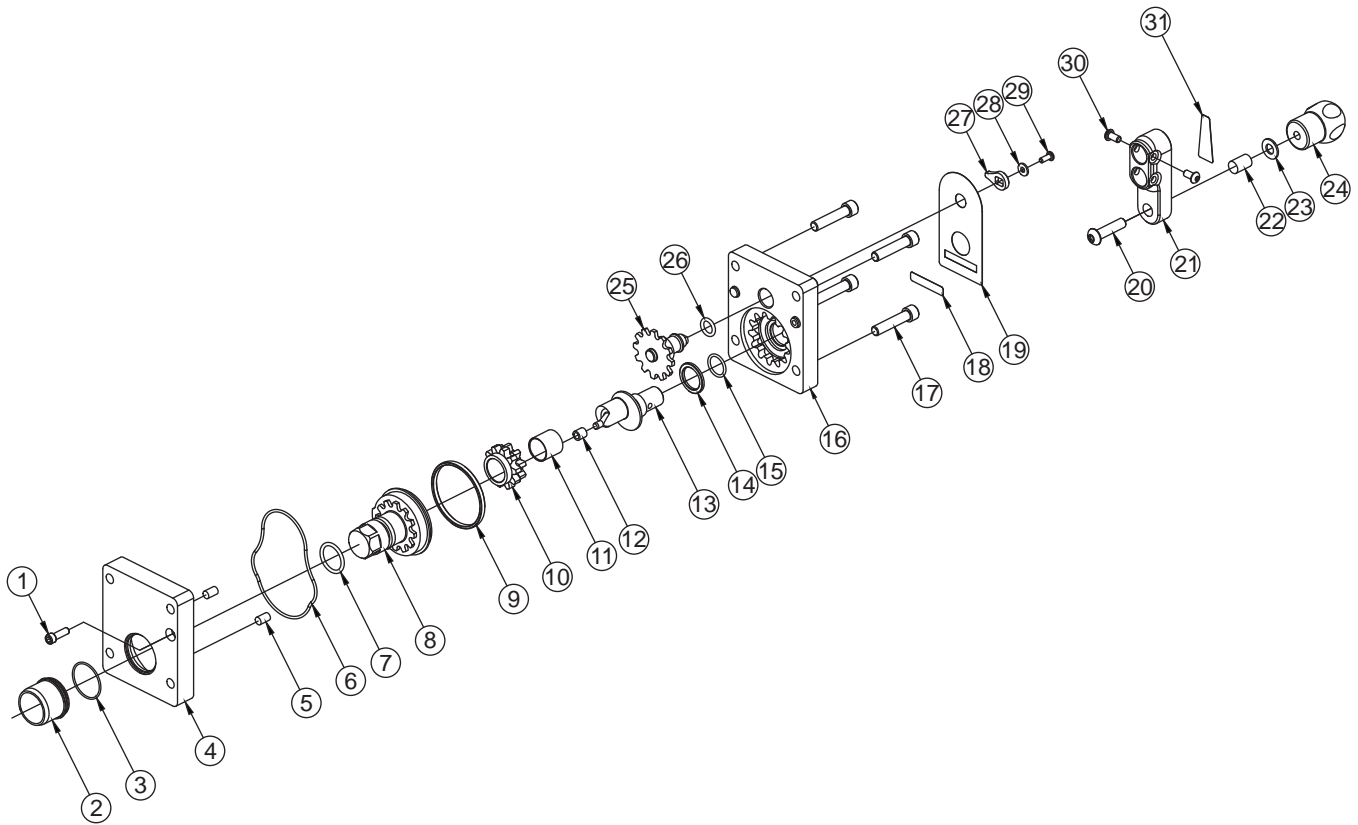

Figure 6.0c  
Exploded View of Parallel Drive Gearbox

**PARALLEL DRIVE GEARBOX**

INDEX	DESCRIPTION	QTY	ITEM #
1	1/4-20 X 3/4 SOCKET HEAD SCREW	1	VT25-20SH750
2	INNER BUSHING	1	A1552
3	O-RING-028	1	VO-028
4	SUBPLATE	1	A1551
5	DOWEL PIN	2	VP312X.50
6	O-RING-154	1	VO-154
7	O-RING-214	1	VO-214
8	INNER TRUNNION	1	A1553
9	BUSHING	1	A1549
10	DOUBLE GEAR	1	A1554
11	GEAR BUSHING	1	A1548
12	NYLON BUSHING	1	AY307
13	DRIVE SHAFT	1	A1555
14	SPACER	1	A1556
15	O-RING-116	1	VO-116
16	GEAR BOX	1	A1550

INDEX	DESCRIPTION	QTY	ITEM #
17	3/8-16 X 1 1/2 SOCKET HEAD SCREW	4	VT37-16SH1.7
18	MODEL NUMBER LABEL	1	A1303
19	BIV NAME LABEL	1	A1550L
20	3/8-16 X 1-1/2 BUTTON HEAD SCREW	1	VT37-16BH1.5
21	CRANK	1	A1559
22	CRANK BUSHING	1	A1547
23	WASHER	1	VW812X406-65
24	KNOB	1	A1512
25	INDICATOR GEAR	1	A1557
26	O-RING-206	1	VO-206
27	POSITION INDICATOR	1	A1558
28	WASHER	1	VW500X203-60
29	10-24 X 3/8 BUTTON HEAD SCREW	1	VT10-24BH500
30	1/4-20 X 1/2 BUTTON HEAD SCREW	2	VT25-20BH500
31	FOLDING HANDLE LABEL	1	AY342

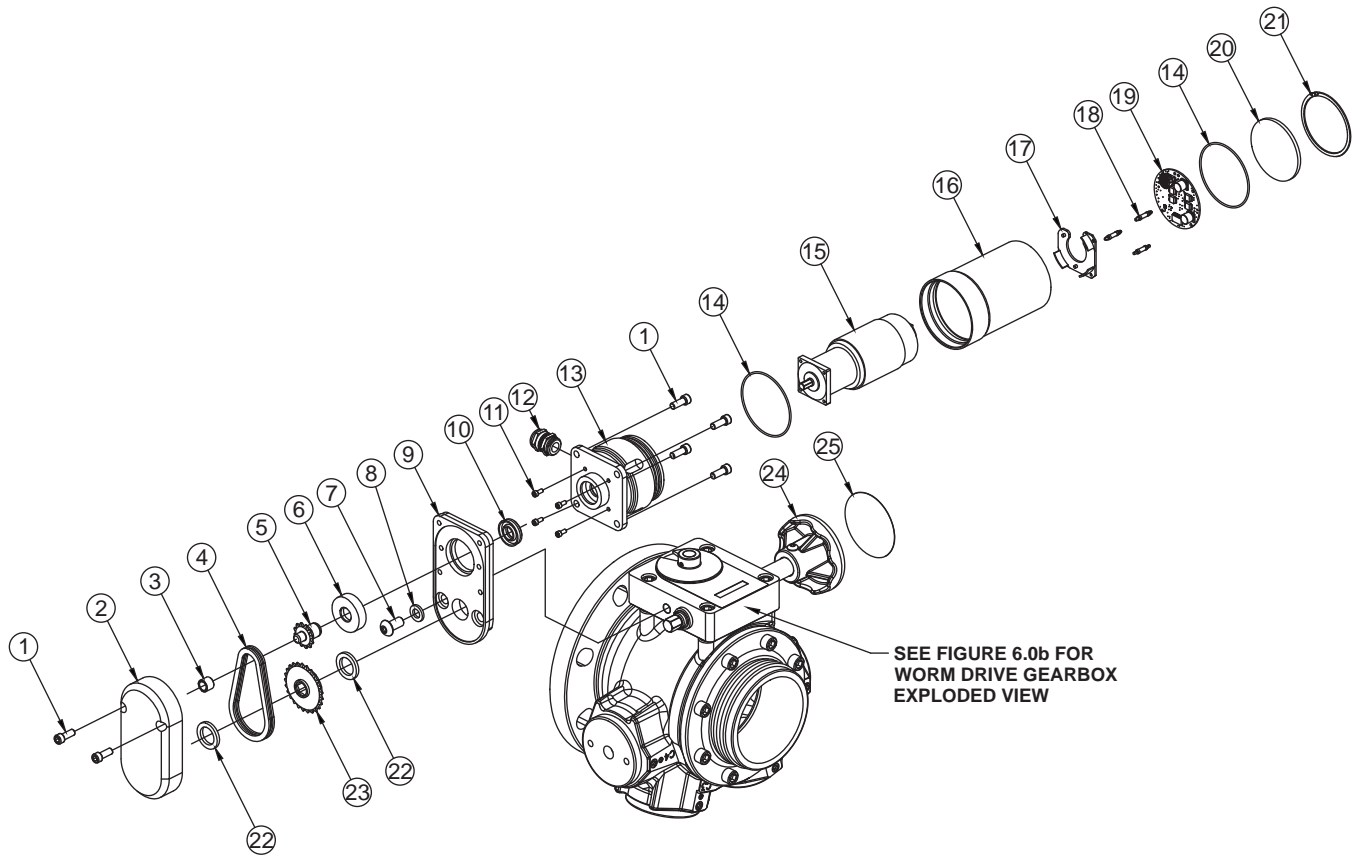

Figure 6.0d  
Exploded View of RC Motor Assembly for Valve Under Monitor RC

**RC MOTOR ASSEMBLY**

INDEX	DESCRIPTION	QTY	ITEM #
1	1/4-28 X 5/8 SOCKET HEAD SCREW	6	VT25-28SH625
2	REDUCER COVER	1	A1097
3	BUSHING NYLON 3/8 X 1/2 X 3/8	1	X252
4	38LINK ROLLER CHAIN S.S. - SUBASSEMBLY	1	AX1685
5	DRIVE SPROCKET	1	X253
6	BUSHING MOTOR	1	X256
7	3/8-16 X 3/4 BUTTON HEAD SCREW	1	VT37-16BH750
8	LOCK WASHER 3/8" STAINLESS 18-8	1	VW375SSLOCK
9	REDUCER HOUSING	1	A1096
10	CUP SEAL 1.0625 X .5625 X 1/4	1	Y4620
11	6-32 X 5/16 LONG SHCS WITH HEAD SEAL	4	VT06S32SH312
12	STRAIN RELIEF PG11 .39 HOLE	1	Y5205
13	MOTOR SOCKET	1	Y4615
14	O-RING-038	2	VO-038
15	GEAR MOTOR	1	Y4600
16	MOTOR ENCLOSURE TUBE	1	Y4641
17	MOTOR BOARD SUPPORT	1	Y4643
18	CIRCUIT BOARD STANDOFF	3	Y5538
19	VALVE MOTOR BOARD	1	A5825
20	MOTOR ENCLOSURE CAP	1	Y4642
21	SMALLEY RING	1	V4295
22	THIN WASHER	2	A1530
23	BIV SPROCKET 25	1	A1098
24	KNOB	1	Z245
25	OVERRIDE KNOB LABEL	1	Y4176

## 7.0 TROUBLE SHOOTING

SYMPTOM	POSSIBLE CAUSE	REMEDY
Leaks	Debris or damage in seal area	Clean out debris or replace damaged parts
Binding, Erratic operation	Low Voltage (see below)	See Below
Power LED on but no operation	Low voltage due to: -wire gage too small -wire length too long -poor connection -inadequate apparatus electrical system	Check connections and wiring per section 4.4
LED D6 on motor board blinks rapidly when button is pressed	Bad motor encoder	Replace motor sub assembly
No Power LED	Polarity reversed or poor connection	Check wiring and correct polarity
Valve operates from valve control but not from RC monitor operator stations	Incorrect communication wiring	Check blue & white communication wiring

## 8.0 MAINTENANCE AND REPAIRS

The Valve Under Monitor requires no routine maintenance. The gearbox is sealed and requires no periodic greasing. Valve seats shall be greased as needed with a silicone based grease such as Dow Corning 112. Any scrapes that expose bare aluminum should be cleaned and touched up with enamel pain such as Rust-Oleum. Replace any missing or damaged parts before returning the valve to service. The valve should be inspected annually and after each use. In particular, check that:

- There are no leaks with the valve off and while flowing.
- Valve control handles move freely between open and closed positions.
- Valve position indicator correctly reflects valve position between open and closed positions.

## 8.1 WORM DRIVE GEARBOX CRANKSHAFT OVERRIDE AND REPLACEMENT

The crankshaft includes an intentional shear joint to protect the gear train from overload, costly repairs and loss of service. The magnitude of torque required to shear the crankshaft is several times greater than the torque typically needed to operate the valve at maximum operating pressure. If the crankshaft breaks during use, this is an indication that either there is something obstructing the half ball internally or the crank shaft has been abused (e.g. used as a step for climbing).

### VERRIDE

In an emergency, the opposite side of the crankshaft can be turned using a 1/2" wrench or hex socket. This allows the valve to be open or closed until the crankshaft is replaced. To prevent loss of the 1/8" square key on the crankshaft, do not allow the crankshaft to slide out of gearbox until a replacement crankshaft is acquired. It is important not to rely on this as a long-term method of operation.

### DIAGNOSIS

To diagnose the problem that caused the crankshaft to fail, complete the following steps:

1. Close upstream water supply. If possible, relieve pressure leading up to valve.
2. Locate 1/2" hex where crankshaft protrudes from opposite side of gearbox.
3. Gently turn crank shaft away from travel stop using a 1/2" hex wrench. Do not attempt to shock crankshaft free and do not exceed 50 ft-lb (68 Nm) of torque.
4. If crankshaft will not rotate, then half ball is likely obstructed. Only after relieving pressure on flanged joint, unbolt valve. Clear any obstructions and evaluate whether repair is needed before returning to service.
5. If crankshaft is able to rotate, cycle the valve several times from open to closed to determine whether the crankshaft binds at any place between the travel stops. If crankshaft binds, consult Task Force Tips Service Department to determine the appropriate repairs.
6. If crankshaft rotates freely after clearing any obstructions, then a replacement crank shaft may be ordered from Task Force Tips and replaced as described below.

### REPLACEMENT

A broken crankshaft can be replaced at any time by completing the following steps, regardless of whether or not the upstream water supply is pressurized. Referring to index numbers shown in figure 6.0b, follow the steps below:

1. Remove external retaining ring (index 18) adjacent to 1/2" hex on crankshaft.
2. Using a punch or Phillips head screwdriver at least 6" in length, gently push on dimple in 1/2" hex end of crankshaft (index 26). Continue to push crankshaft through until it protrudes from opposite side of gearbox.
3. Grab broken end of crankshaft and pull out of gearbox. As crankshaft is withdrawn, grasp small key (index 27) on shaft so it does not get lost.
4. If 1/8" square x 1" long key is not visible in shaft, it has likely fallen into gearbox bore and must be removed before installing new crankshaft. If square key is visible in gearbox bore, slide it out of bore. Needle-nose pliers may be helpful depending on position of key in bore.
5. Verify polymer bushings (index 20 and 25) are still seated in bores on each side of gearbox. If not, locate and replace bushings.
6. Look through gearbox bore and note approximate orientation of square keyway in worm (index 23). Verify round notch in thrust washer (index 22) is aligned with square keyway in worm.
7. Prepare new crankshaft by applying small dab of grease to keyway and seating 1/8" square x 1" long key into keyway. Grease will keep key in place during assembly.
8. Slide shaft into gearbox with key orientation the same as keyway in worm. Rotate shaft slightly in alternating directions until key finds keyway, then push shaft in until it stops. Retaining ring groove and 1/2" hex should be protruding through opposite side of gearbox. If hex is not visible, it may be necessary to slide polymer bushing back into gearbox bore.
9. Install retaining ring (index 18) onto shaft. Do not over-expand the retaining ring.



## 8.2 VALVE SEAT REPLACEMENT



Applying greater than 200 in-lbs (17 ft-lbs) torque to Side B Outlet Adapter screws may damage the valve body. Injury could result from use after damaging the valve body.



Safety goggles are recommended to avoid eye injury while checking for leaks without the monitor installed.

Valve seats may be replaced in the field if it becomes a source of leakage due to harsh environmental conditions or excessive age. For the valve seats in the 2.5" hydrant valve and gated elbow options, see LIA-355. For the main valve seat included in all VUMs, follow the steps below referring to index numbers shown in figure 7.0a:

1. Close upstream water supply and relieve pressure leading up to valve.
2. Remove the monitor from the VUM, then remove the Side B Outlet Adapter. This procedure varies depending on connection type.
  - a. For models with a 4" ANSI 150 / DN100 PN16 flange installed on side B (index 19), loosen screws (index 28) using a 5/32" male hex wrench (Allen wrench) until two-piece clamp can move freely. Next, unscrew flange from assembly.
  - b. For all models, remove (8) Socket Head Cap Screws (index 27) from Side B Outlet Adapter (index 20 through 26) using a 5/16" male hex wrench (Allen wrench).
  - c. Remove Side B Outlet Adapter. If a VUM Outlet Shim (index 10) is also present between Adapter and Valve Body, remove Shim.
3. Pull old Valve Seat (index 9) out of counter-bore in Valve Body (index 1). Observe whether or not there is text "A1520 – NITRILE RUBBER" visible on the wider side (upstream facing side) of the valve seat.
4. Clean sealing surfaces of Half Ball (index 2), Valve Body (index 1), and Side B Outlet Adapter (index 20 through 26). Verify all sealing surfaces are smooth and intact. If significant damage is visible, consult Task Force Tips Service Dept.
5. Apply light coat of silicone based grease such as Dow Corning 112 to all sealing surfaces of Half Ball, Valve Body, and Side B Outlet Adapter. Open valve so Half Ball is out of the way.
6. Install new Valve Seat (index 9) into counter-bore in valve body with wider side facing the half ball.
7. The VUM Outlet Shim may or may not be needed. Install a new Shim if either of the following conditions are true:
  - a. A Shim was observed in step 2c.
  - b. The text "A1520 – NITRILE RUBBER" was observed on the old Valve Seat in step 5.
8. Align screw holes of Side B Outlet Adapter with Valve Body in desired orientation, then press firmly on outlet side of Adapter until it slides into inner diameter of Valve Seat.
9. Apply Loctite #242 (blue) to (8) Socket Head Cap Screws (index 28). Install Screws through Adapter into Valve Body, then gradually tighten each Screw three times in the alternating sequence of figure 4.2, stopping at a torque of 180 to 200 in-lbs (15 to 17 ft-lbs).
10. Manually close the valve and observe whether the operator effort is excessive as the valve approaches the CLOSED travel stop. If so, it may be necessary to install the VUM Outlet Shim as described in step 9.
11. Reinstall the valve according to instruction in section 4.2, then restore the water supply to it.
12. Open the valve approximately 10 degrees to bleed air out of the standpipe, then close the valve. Verify that the valve seat does not leak when the valve is closed. It may be helpful to soak up excess water with a sponge or absorbent cloth. If leakage is observed, consult Task Force Tips Service Department.
13. Reinstall monitor according to instructions in section 4.3.

## 9.0 PRESSURE LOSS

The flow coefficients and graph below apply to all models of the Valve Under Monitor. Data shown is for from the VUM inlet to the specified outlet only and does not include monitor, nozzle or hose pressure losses. The Cv flow coefficients below are calculated according to the formula:

$$C_v = \frac{Q}{\sqrt{\Delta P}}$$

Where Cv = flow coefficient, Q = flow rate in gpm and ΔP = pressure loss in psi across valve (applies for water only).

- For the main valve to the monitor, Cv = **815**
- For an auxiliary port with a 2.5" gated elbow installed (options 2, 3, B and C), Cv = **141**
- For an auxiliary port with a 2.5" straight valve installed (options 4 and D), Cv = **153**
- For an auxiliary port with no valve installed (options 5, 6, E and F), Cv = **212**

To calculate pressure loss for a given flow rate through each port, this formula can be rearranged as:  $\Delta P = \frac{Q^2}{C_v^2}$

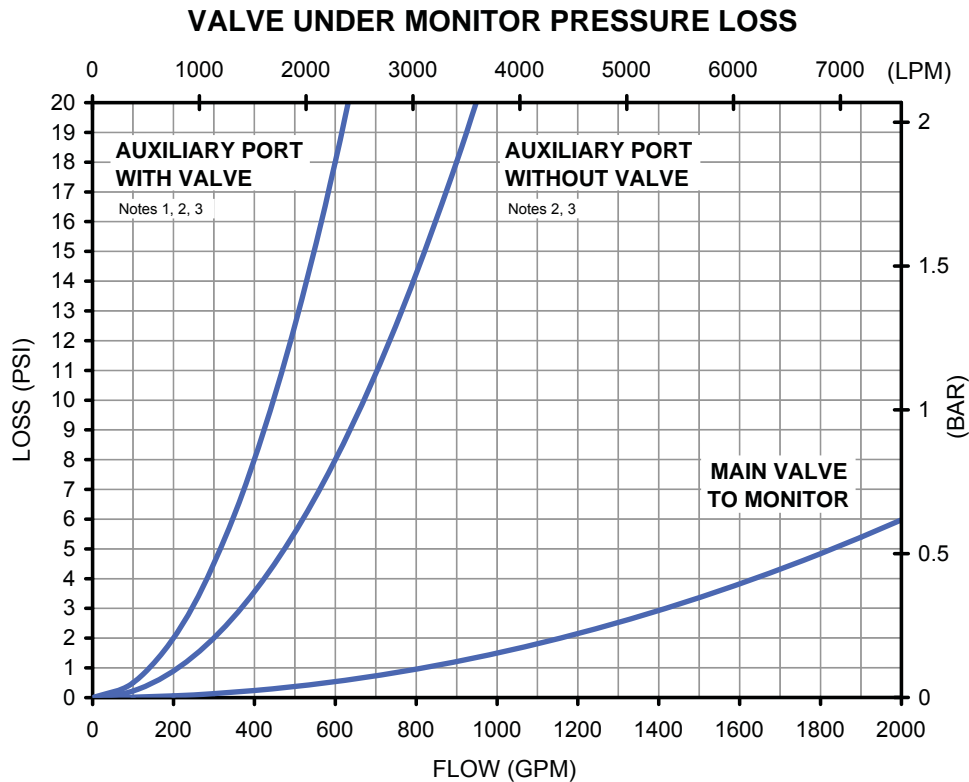

### NOTES:

- 1) Curve represents auxiliary port options 2 and 3 (gated elbows). Pressure loss for auxiliary port option 4 (straight hydrant valve) is about 15% less than indicated.
- 2) When valve to monitor is open, pressure loss through auxiliary ports C3 and C4 may be up to 50% greater than indicated. Auxiliary ports C1 and C2 are not affected by this condition.
- 3) Extension pipes (auxiliary port options B through F) do not add significant pressure loss.

## 10.0 TEMPLATES



Hole Location for Enclosure

## 11.0 WARRANTY

Task Force Tips, Inc., 3701 Innovation Way, Valparaiso, Indiana 46383-9327 ("TFT") warrants to the original purchaser of its Valve Under Monitor and Valve Under Monitor RC ("equipment"), and to anyone to whom it is transferred, that the equipment shall be free from defects in material and workmanship during the five (5) year period from the date of purchase.

TFT's obligation under this warranty is specifically limited to replacing or repairing the equipment (or its parts) which are shown by TFT's examination to be in a defective condition attributable to TFT. To qualify for this limited warranty, the claimant must return the equipment to TFT, at 3701 Innovation Way, Valparaiso, Indiana 46383-9327, within a reasonable time after discovery of the defect. TFT will examine the equipment. If TFT determines that there is a defect attributable to it, TFT will correct the problem within a reasonable time. If the equipment is covered by this limited warranty, TFT will assume the expenses of repair.

If any defect attributable to TFT under this limited warranty cannot be reasonably cured by repair or replacement, TFT may elect to refund the purchase price of the equipment, less reasonable depreciation, in complete discharge of its obligations under this limited warranty. If TFT makes this election, claimant shall return the equipment to TFT free and clear of any liens and encumbrances.

This is a limited warranty. The original purchaser of the equipment, any person to whom it is transferred, and any person who is an intended or unintended beneficiary of the equipment, shall not be entitled to recover from TFT any consequential or incidental damages for injury to person and/or property resulting from any defective equipment manufactured or assembled by TFT. It is agreed and understood that the price stated for the equipment is in part consideration for limiting TFT's liability. Some states do not allow the exclusion or limitation of incidental or consequential damages, so the above may not apply to you.

TFT shall have no obligation under this limited warranty if the equipment is, or has been, misused or neglected (including failure to provide reasonable maintenance) or if there have been accidents to the equipment or if it has been repaired or altered by someone else.

THIS IS A LIMITED EXPRESS WARRANTY ONLY. TFT EXPRESSLY DISCLAIMS WITH RESPECT TO THE EQUIPMENT ALL IMPLIED WARRANTIES OF MERCHANTABILITY AND ALL IMPLIED WARRANTIES OF FITNESS FOR A PARTICULAR PURPOSE. THERE IS NO WARRANTY OF ANY NATURE MADE BY TFT BEYOND THAT STATED IN THIS DOCUMENT.

This limited warranty gives you specific legal rights, and you may also have other rights which vary from state to state.

## 12.0 ANSWERS TO YOUR QUESTIONS

We appreciate the opportunity of serving you and making your job easier. If you have any problems or questions, our toll-free "Hydraulics Hotline", 800-348-2686, is normally available to you 24 hours a day, 7 days a week.