



MANUAL: Jumbo Siamese and Jumbo Wye

INSTRUCTIONS FOR SAFE OPERATION AND MAINTENANCE

WARNING

Understand manual before use. Operation of this device without understanding the manual and receiving proper training is a misuse of this equipment. Obtain safety information at www.tft.com/serial-number

This instruction manual is intended to familiarize firefighters and maintenance personnel with the operation, servicing and safety procedures associated with the Jumbo Siamese and Jumbo Wye.

This manual should be kept available to all operating and maintenance personnel.

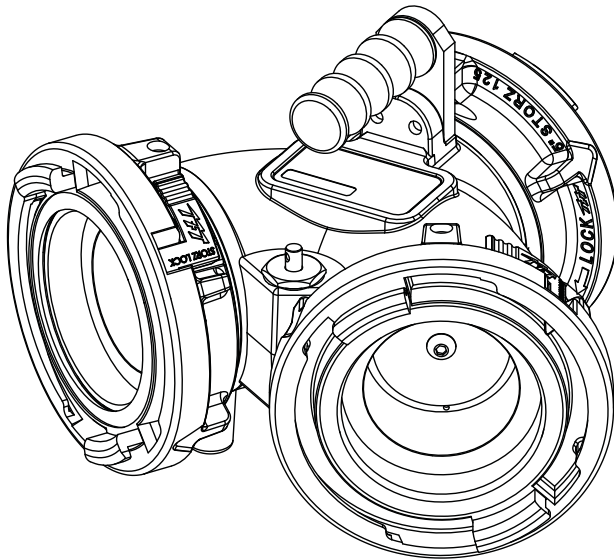

JUMBO SIAMESE
AS4ST-ST

**Hydrostatic
Proof Test:
900 PSI**

**OPERATING RANGE:
Pressure Max 250 PSI
Pressure Min Full Vac.**

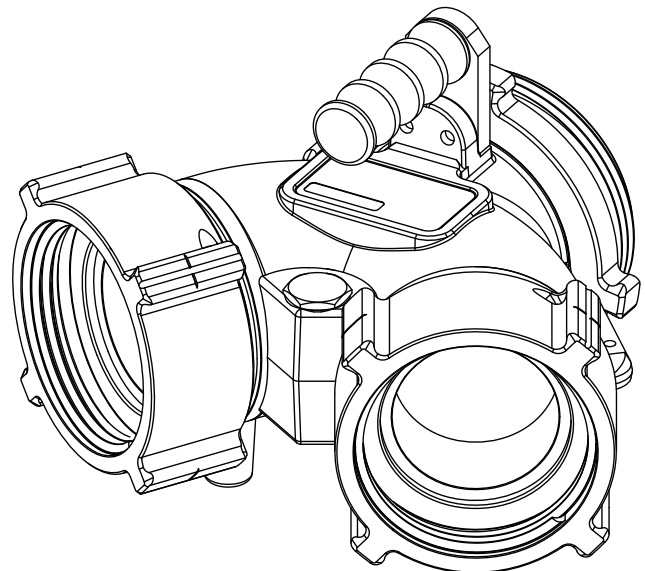

JUMBO WYE
AW5NT-NT

TASK FORCE TIPS, INC.
MADE IN USA • www.tft.com

3701 Innovation Way, Valparaiso, IN 46383-9327 USA
800-348-2686 • 219-462-6161 • Fax 219-464-7155

TABLE OF CONTENTS

1.0	MEANING OF SIGNAL WORDS
1.1	SAFETY
2.0	GENERAL INFORMATION
2.1	CORROSION
2.2	USE WITH SALT WATER
3.0	INSTALLATION
4.0	USE
5.0	DRAWINGS AND PARTS LISTS
6.0	MAINTENANCE
7.0	WARRANTY



PERSONAL RESPONSIBILITY CODE

The member companies of FEMSA that provide emergency response equipment and services want responders to know and understand the following:

1. Firefighting and Emergency Response are inherently dangerous activities requiring proper training in their hazards and the use of extreme caution at all times.
2. It is your responsibility to read and understand any user's instructions, including purpose and limitations, provided with any piece of equipment you may be called upon to use.
3. It is your responsibility to know that you have been properly trained in Firefighting and/or Emergency Response and in the use, precautions, and care of any equipment you may be called upon to use.
4. It is your responsibility to be in proper physical condition and to maintain the personal skill level required to operate any equipment you may be called upon to use.
5. It is your responsibility to know that your equipment is in operable condition and has been maintained in accordance with the manufacturer's instructions.
6. Failure to follow these guidelines may result in death, burns or other severe injury.



Fire and Emergency Manufacturers and Service Association
P.O. Box 147, Lynnfield, MA 01940 • www.FEMSA.org

1.0 MEANING OF SAFETY WORDS

A safety related message is identified by a safety alert symbol and a signal word to indicate the level of risk involved with a particular hazard. Per ANSI standard Z535.6-2011, the definitions of the four signal words are as follows:

 **DANGER** indicates a hazardous situation which, if not avoided, will result in death or serious injury.

 **WARNING** indicates a hazardous situation which, if not avoided, could result in death or serious injury.

 **CAUTION** indicates a potentially hazardous situation which, if not avoided, could result in minor or moderate injury.

 **NOTICE** is used to address practices not related to physical injury.

1.1 SAFETY

WARNING

This equipment is intended for use by trained personnel for firefighting. Its use for other purposes may involve hazards not addressed by this manual. Seek appropriate guidance and training to reduce risk of injury.

WARNING

Burst hoses and fittings can result in injury or death. Maximum operating pressure of TFT's Jumbo Siamese and Jumbo Wye is 250 psi (17 bar). Do not exceed 250 PSI on either side of the appliance.

WARNING

The appliance may be damaged if frozen while containing significant amounts of water. Such damage may be difficult to detect visually and can lead to possible injury or death. Any time the appliance is subject to possible damage due to freezing, it must be hydrostatically tested by qualified personnel before being considered safe for use.

CAUTION

Any alterations to the Jumbo Siamese, the Jumbo Wye and its markings could diminish safety and constitutes a misuse of this product.

2.0 GENERAL INFORMATION

The Jumbo Siamese and Jumbo Wye are intended for use in a hose line, on a fire hydrant, or an intake or discharge manifold of a fire truck.

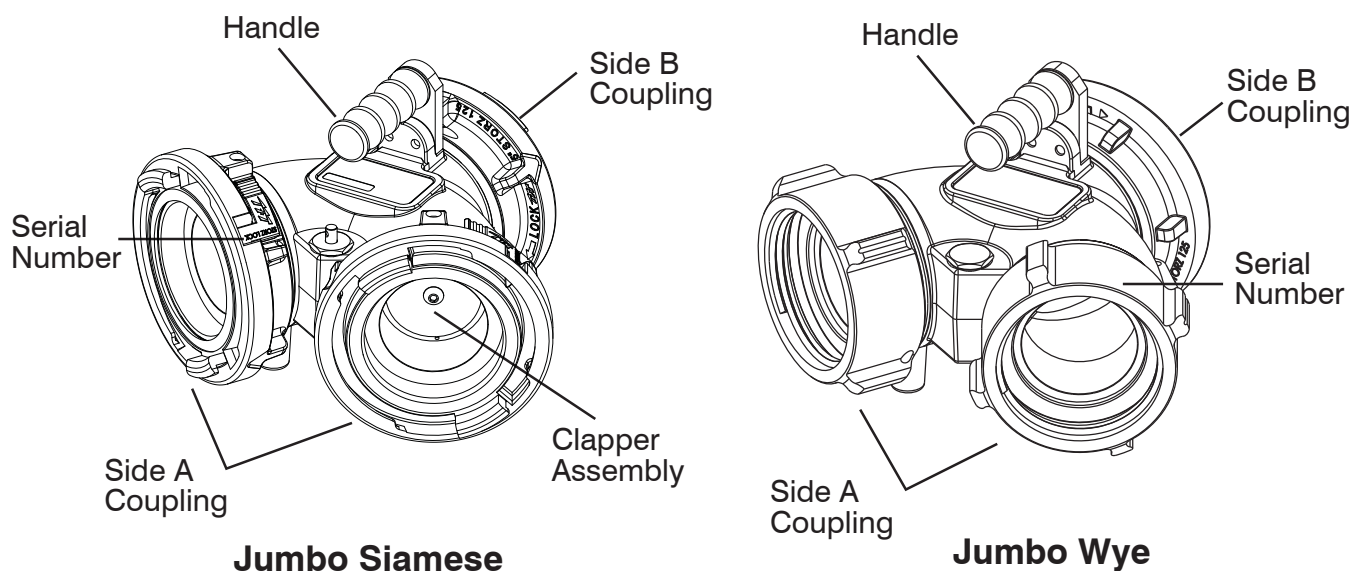

2.1 CORROSION

The aluminum castings are hardcoat anodized, and TFT powdercoat finished inside and out for maximum corrosion protection. Hose couplings are attached using polymer bearing rings which provides electrical isolation to help prevent galvanic corrosion. The effects of corrosion can be minimized by good maintenance practices. See Section 7.0 for maintenance.

2.2 USE WITH SALT WATER

NOTICE

Use with salt water is permissible provided valve is thoroughly cleaned with fresh water after each use. The service life of the valve may be shortened due to the effects of corrosion and is not covered under warranty.

3.0 INSTALLATION

Make connections to fire hose or fittings on each side of the Jumbo Siamese or Jumbo Wye.

⚠ WARNING

Kinks in supply hose may reduce water flow and cause injury or death to persons dependant on water flow. When this valve is used on a hydrant or fire truck it is recommended that it be used with an elbow to minimize risk of hoseline kinks.

⚠ CAUTION

Jumbo Siamese and Jumbo Wye's must be properly connected. Mismatched or damaged connectors may cause leaking or uncoupling under pressure and could cause injury.

⚠ CAUTION

Dissimilar metals coupled together can cause galvanic corrosion that can result in the inability to unscrew the threads or complete loss of thread engagement over time. Per NFPA 1962, if dissimilar metals are left coupled together an anti-corrosive lubricant should be applied to the threads. Also the coupling should be disconnected and inspected at least quarterly.

⚠ CAUTION

Male fire hose threads are sharp and can cause injury. Be careful when grasping male threads.

4.0 USE

The couplings of Siamese and Wye models swivel to help prevent hose kinks, and make hose connection easier. Male hose thread connections are locked so that they will not rotate.

The Jumbo Wye fitting can be used to join the flow of two water sources together into one, or in the opposite direction to split one water source into two. The flow direction in our out of any opening is possible.

The Jumbo Siamese valve can only flow water in one direction ONLY. Water entering from either one or both Side A will exit through the single Side B discharge outlet. Dual swinging clapper valves make the Jumbo Siamese an ideal appliance for tanker shuttle operations. Dual clappers allow one or both inlets to be disconnected without losing water from a hose line attached to Side B.

⚠ CAUTION

Jumbo Siamese will not flow water from Side B to both Side A openings. Do not attempt to flow water in one Side A opening and out of the other Side A opening. This valve contains dual swinging clapper assemblies, that will prevent backflow through the Side A openings.

JUMBO SIAMESE OPERATION

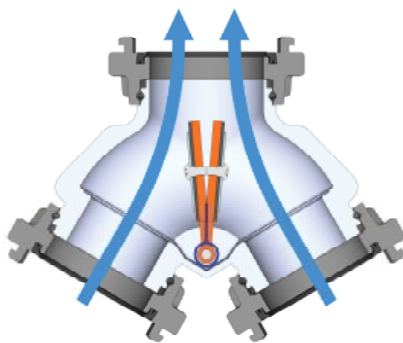

Both Inlets Flowing

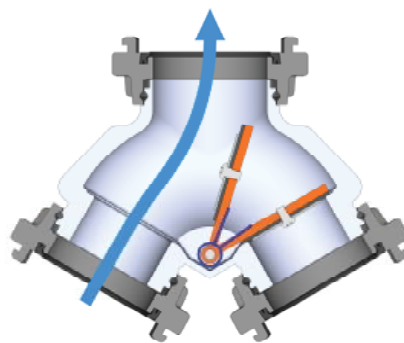

One Inlet Flowing

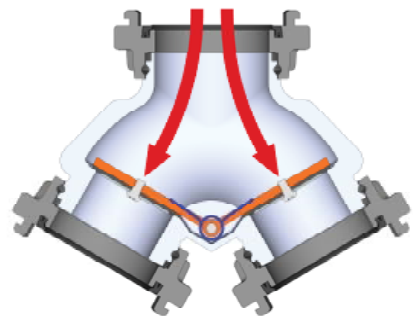

Both Inlets Closed

5.0 EXPLODED VIEW AND PARTS LIST

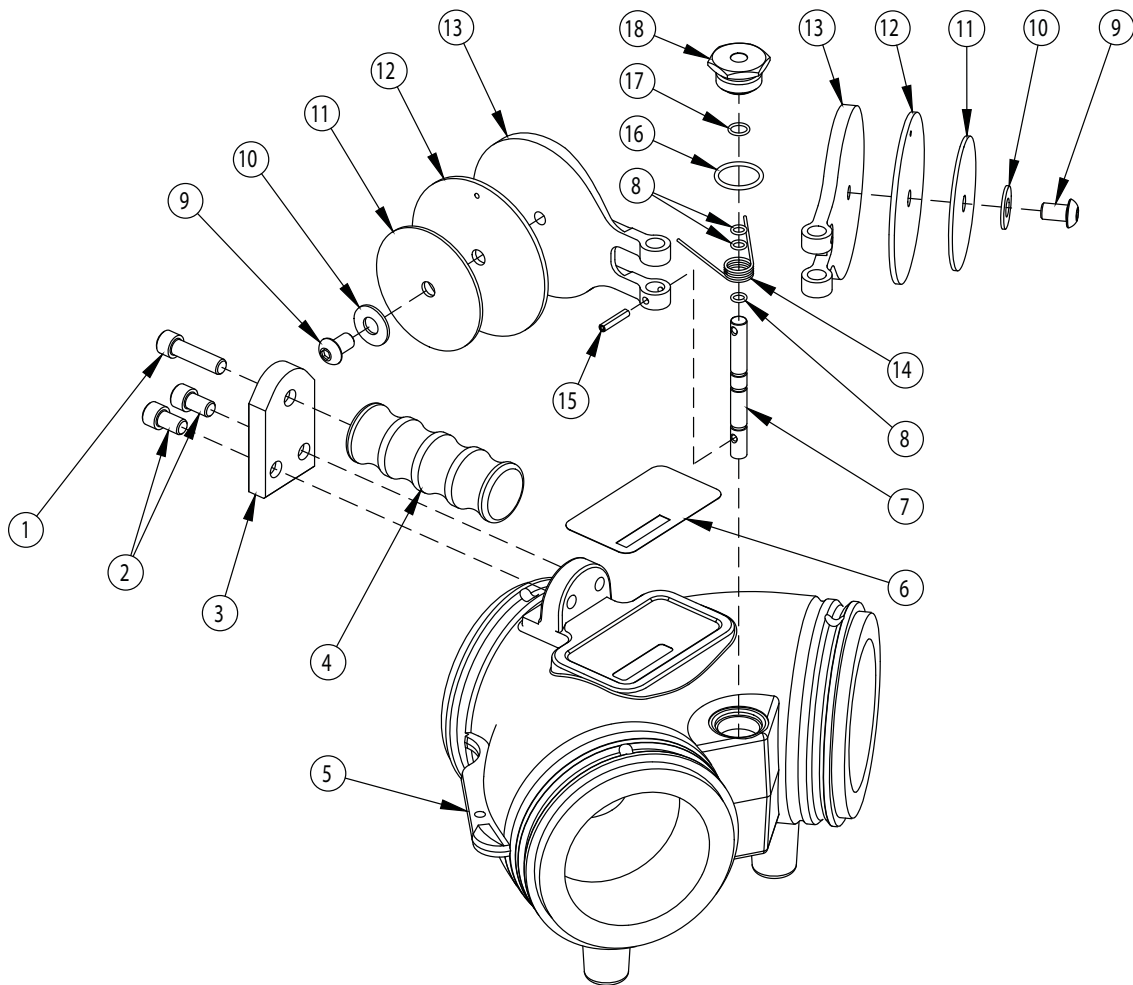

Table 1: Jumbo Siamese Parts List

#	PART DESCRIPTION	QTY	PART NUMBER
1	3/8 - 16 X 7/8 SOCKET HEAD CAP SCREW	1	VT37-16SH875
2	3/8 - 16 X 5/8 SOCKET HEAD CAP SCREW	2	VT37-16SH625
3	TOMBSTONE	1	X365
4	PEG	1	X362
5	WYE BODY 5.0"	1	A5710
6	SIAMESE NAME LABEL	1	A1304
7	PIVOT PIN	1	A5732
8	O-RING-010 1/4 ID 1/16 C/S	3	VO-010
9	3/8-16 X 5/8 BUTTON HEAD CAP SCREW	2	VT37-16BH625
10	WASHER 1.0 O.D X .438 I.D X .07TK	2	VW1.0X437-07
11	WASHER	2	A5752
12	GASKET	2	A5762
13	CLAPPER 4"	2	A5720
14	TORSION SPRING 90DEG RT 3.37 IN-LB	1	A5740
15	SPIROL PIN 5/32 X 7/8	1	V1900
16	O-RING-119 15/16 ID 3/32 C/S	1	VO-119
17	O-RING-012 3/8 ID 1/16 C/S	1	VO-012
18	PIVOT CAP	1	G191

5.0 EXPLODED VIEW AND PARTS LIST

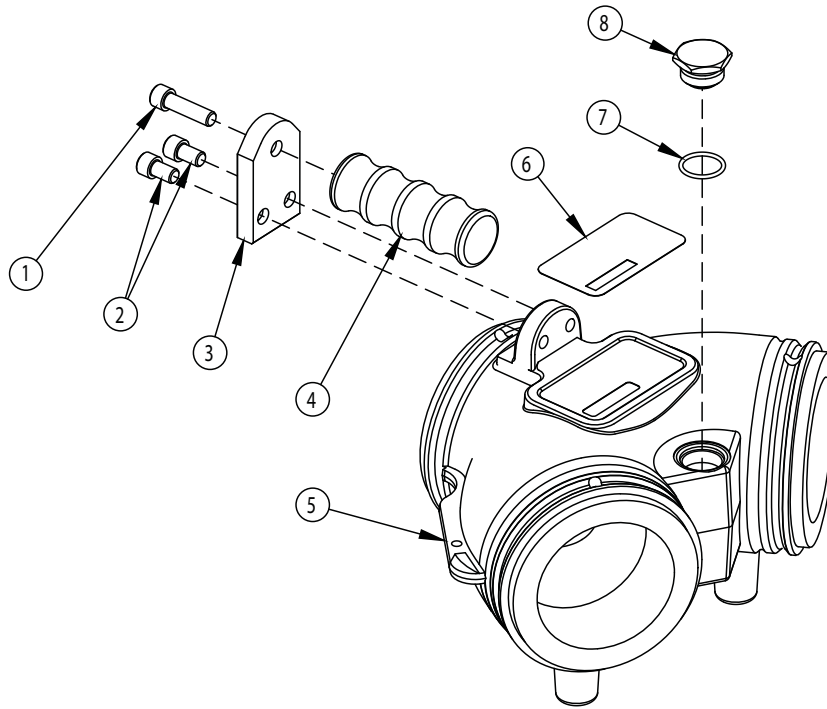

Table 2: Jumbo Wye Parts List

#	PART DESCRIPTION	QTY	PART #
1	3/8 - 16 X 7/8 SOCKET HEAD CAP SCREW	1	VT37-16SH875
2	3/8 - 16 X 5/8 SOCKET HEAD CAP SCREW	2	VT37-16SH625
3	TOMBSTONE	1	X365
4	PEG	1	X362

#	PART DESCRIPTION	QTY	PART #
5	WYE BODY 5.0"	1	A5710
6	WYE NAME LABEL	1	A1305
7	O-RING-119 15/16 ID 3/32 C/S	1	VO-119
8	TOP CAP	1	G190

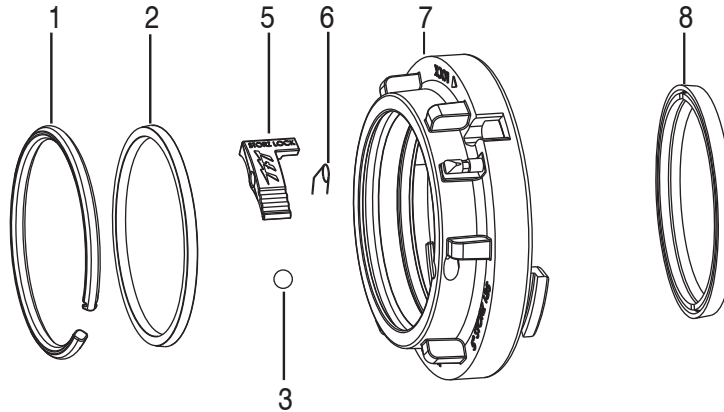

Table 3: Storz Coupling Parts List

#	PART DESCRIPTION	QTY	PART #
1	PLASTIC STRIP 4.25" (FOR 4 INCH STORZ)	1	A1292
	PLASTIC STRIP 5.25"	1	A1291
2	CUP SEAL 4.25 X 3.75 X 1/4 (FOR 4 INCH STORZ)	1	A1297
	CUP SEAL 5.25 X 4.75 X 1/4	1	A1296
3	BALL 7/16" STAINLESS (FOR LOCKED OUT COUPLINGS)	1	VB.437
5	LOCKING LEVER	1	A4171
6	SPRING TORSION	1	A4230

#	PART DESCRIPTION	QTY	PART #
7	4" STORZ FITTING (USES A4730 ADAPTER)	1	A4124
	5" STORZ FITTING	1	A4125
	6" STORZ FITTING	1	A4126
8	4" STORZ GASKET PRESSURE ONLY	1	A4215
	4" STORZ GASKET PRESSURE/VACUUM	1	A4216
	5" STORZ GASKET PRESSURE ONLY	1	A4220
	5" STORZ GASKET PRESSURE/VACUUM	1	A4221
	6" STORZ GASKET PRESSURE ONLY	1	A4226
	6" STORZ GASKET PRESSURE/VACUUM	1	A4226

5.0 EXPLODED VIEW AND PARTS LIST

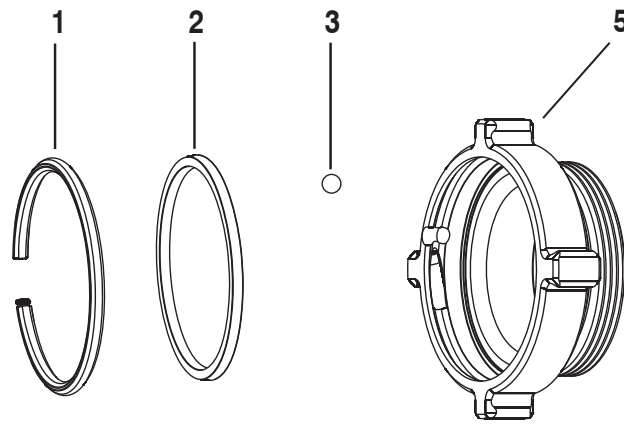

Table 4: Male Thread Spout Parts List

#	Part Description	Qty	Part #
1	PLASTIC STRIP 5.25"	1	A1291
2	CUP SEAL 5.25 X 4.750 X 1/4	1	A1296
3	BALL 7/16" STAINLESS	1	VB.437
5	4.0" NH MALE SPOUT	1	A4620N
	4.5" NH MALE SPOUT	1	A4625N
	5.0" NH MALE SPOUT	1	A4630N
	6.0" NH MALE SPOUT	1	A4635N

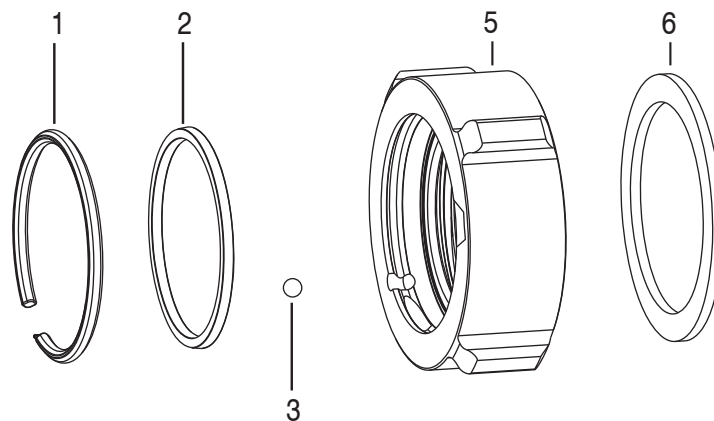

Table 5: Female Thread Coupling Parts List

#	Part Description	Qty	Part #
1	PLASTIC STRIP 5.25"	1	A1291
	PLASTIC STRIP 7.00" (FOR 6.0" FEMALE THREADED COUPLINGS)	1	A1290
2	CUP SEAL 5.25 (FOR 4.0" THRU 5.0" COUPLING ONLY)	1	A1296
3	BALL 7/16" STAINLESS (FOR LOCKED OUT COUPLINGS)	1	VB.437
5	4.0" NH FEMALE	1	A4660N
	4.5" NH FEMALE	1	A4665N
	5.0" NH FEMALE	1	A4670N
	6.0" NH FEMALE (USES A4745 ADAPTER)	1	A1266NX
6	4.0" HOSE COUPLING GASKET	1	V3198
	4.5" HOSE COUPLING GASKET	1	V3220
	5.0" HOSE COUPLING GASKET	1	V3210
	6.0" HOSE COUPLING GASKET	1	V3240

6.0 MAINTENANCE

The Jumbo Siamese and Jumbo Wye should be cleaned and visually inspected inside and out at least once per month. Moving parts such as clapper and couplings should be checked for smooth and free operation and greased as needed. A silicone based grease such as Dow Corning 44 will exclude moisture and retard the effects of corrosion. Any scrapes that expose bare aluminum should be touched up with enamel paint such as Rust-Oleum to inhibit corrosion. Replace any missing or damaged parts before returning the appliance to service.

All replacement parts must be obtained from the manufacturer to assure proper operation of the product, and to maintain approval of the device.

7.0 WARRANTY

Task Force Tips, Inc., 3701 Innovation Way, Valparaiso, Indiana 46383-9327 ("TFT") warrants to the original purchaser of its Jumbo Siamese or Jumbo Wye ("equipment"), and to anyone to whom it is transferred, that the equipment shall be free from defects in material and workmanship during the five (5) year period from the date of purchase.

TFT's obligation under this warranty is specifically limited to replacing or repairing the equipment (or its parts) which are shown by TFT's examination to be in a defective condition attributable to TFT. To qualify for this limited warranty, the claimant must return the equipment to TFT, at 3701 Innovation Way, Valparaiso, Indiana 46383-9327, within a reasonable time after discovery of the defect. TFT will examine the equipment. If TFT determines that there is a defect attributable to it, TFT will correct the problem within a reasonable time. If the equipment is covered by this limited warranty, TFT will assume the expenses of repair.

If any defect attributable to TFT under this limited warranty cannot be reasonably cured by repair or replacement, TFT may elect to refund the purchase price of the equipment, less reasonable depreciation, in complete discharge of its obligations under this limited warranty. If TFT makes this election, claimant shall return the equipment to TFT free and clear of any liens and encumbrances.

This is a limited warranty. The original purchaser of the equipment, any person to whom it is transferred, and any person who is an intended or unintended beneficiary of the equipment, shall not be entitled to recover from TFT any consequential or incidental damages for injury to person and/or property resulting from any defective equipment manufactured or assembled by TFT. It is agreed and understood that the price stated for the equipment is in part consideration for limiting TFT's liability. Some states do not allow the exclusion or limitation of incidental or consequential damages, so the above may not apply to you.

TFT shall have no obligation under this limited warranty if the equipment is, or has been, misused or neglected (including failure to provide reasonable maintenance) or if there have been accidents to the equipment or if it has been repaired or altered by someone else.

THIS IS A LIMITED EXPRESS WARRANTY ONLY. TFT EXPRESSLY DISCLAIMS WITH RESPECT TO THE EQUIPMENT ALL IMPLIED WARRANTIES OF MERCHANTABILITY AND ALL IMPLIED WARRANTIES OF FITNESS FOR A PARTICULAR PURPOSE. THERE IS NO WARRANTY OF ANY NATURE MADE BY TFT BEYOND THAT STATED IN THIS DOCUMENT.

This limited warranty gives you specific legal rights, and you may also have other rights which vary from state to state.