



**TASK FORCE TIPS**  
**FIRE FIGHTING EQUIPMENT**

# MANUAL: 2.5" Hydrant Gate Valve

## INSTRUCTIONS FOR SAFE OPERATION AND MAINTENANCE

*This instruction manual is intended to familiarize firefighters and maintenance personnel with the operation, servicing and safety procedures associated with the 2.5 Hydrant Gate Valve.*

*This manual should be kept available to all operating and maintenance personnel.*

### **⚠ WARNING**

Read instruction manual before use. Operation of this device without understanding the manual and receiving proper training is a misuse of this equipment. A person who has not read and understood all operating and safety instructions is not qualified to operate the 2.5" Hydrant Gate Valve.

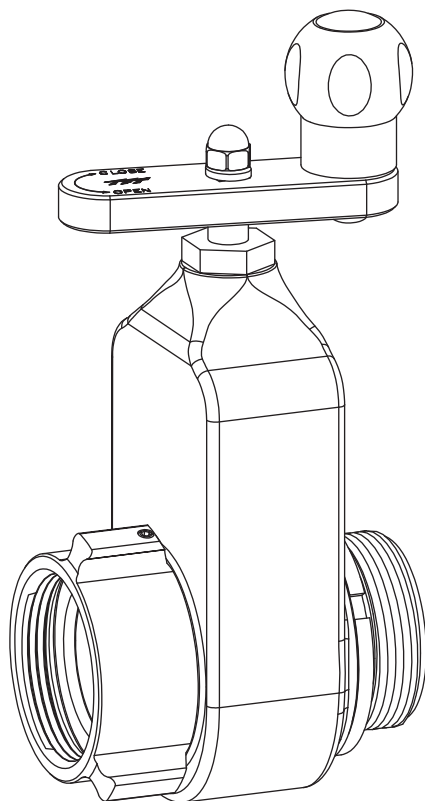

### **⚠ DANGER**

#### PERSONAL RESPONSIBILITY CODE

The member companies of FEMSA that provide emergency response equipment and services want responders to know and understand the following:

1. Firefighting and Emergency Response are inherently dangerous activities requiring proper training in their hazards and the use of extreme caution at all times.
2. It is your responsibility to read and understand any user's instructions, including purpose and limitations, provided with any piece of equipment you may be called upon to use.
3. It is your responsibility to know that you have been properly trained in Firefighting and /or Emergency Response and in the use, precautions, and care of any equipment you may be called upon to use.
4. It is your responsibility to be in proper physical condition and to maintain the personal skill level required to operate any equipment you may be called upon to use.
5. It is your responsibility to know that your equipment is in operable condition and has been maintained in accordance with the manufacturer's instructions.
6. Failure to follow these guidelines may result in death, burns or other severe injury.



Fire and Emergency Manufacturers and Services Association, Inc.  
P.O. Box 147, Lynnfield, MA 01940 • www.FEMSA.org

**TASK FORCE TIPS, Inc.**  
MADE IN USA • www.tft.com

3701 Innovation Way, Valparaiso, IN 46383-9327 USA  
800-348-2686 • 219-462-6161 • Fax 219-464-7155

## 1.0 MEANING OF SAFETY WORDS

A safety related message is identified by a safety alert symbol and a signal word to indicate the level of risk involved with a particular hazard. Per ANSI standard Z535.4-1998 the definitions of the three signal words are as follows:



**DANGER** indicates an imminently hazardous situation which, if not avoided, will result in death or serious injury.



**WARNING** indicates a potentially hazardous situation which, if not avoided, could result in death or serious injury.



**CAUTION** indicates a potentially hazardous situation which, if not avoided, may result in minor or moderate injury.

## 2.0 GENERAL INFORMATION

The 2.5" Hydrant Gate Valve is intended for pressure service on standpipes, fire pumps and hydrants. When used with a pump, the valve is kept closed while the water supply from a hydrant or another pump is being established. This prevents the pump from sucking air through its intake and losing its prime. Once the supply hose is filled and under pressure, the valve may be opened to connect the pump to the water supply.

### 2.1 CORROSION

The Hydrant Gate Valve is sold in either an aluminum or a brass version. All aluminum parts are hardcoat anodized for corrosion protection. Both versions feature a bronze gate and stem and an Aluminum-Bronze alloy seat resulting in low wear and good seal. The exterior of both aluminum and brass valve versions is painted. The effects of corrosion can be minimized by good maintenance practices. See Section 5.0 for maintenance.

### 2.2 USE WITH SALT WATER

Use with salt water is permissible provided the valve is thoroughly cleaned with fresh water after each use. The service life of the valve may be shortened due to the effects of corrosion and is not covered under warranty.

## 3.0 INSTALLATION AND USE

Make connections to fire hose or fittings on each side of the valve. For proper sealing, water must flow from the female rockerlug inlet to the fixed male outlet.

To open the valve, turn the crank in a counter-clockwise direction until it cannot be turned. To close, turn the crank the opposite way until it cannot be turned.

**Operating Range:  
Pressure Max. 250 PSI**

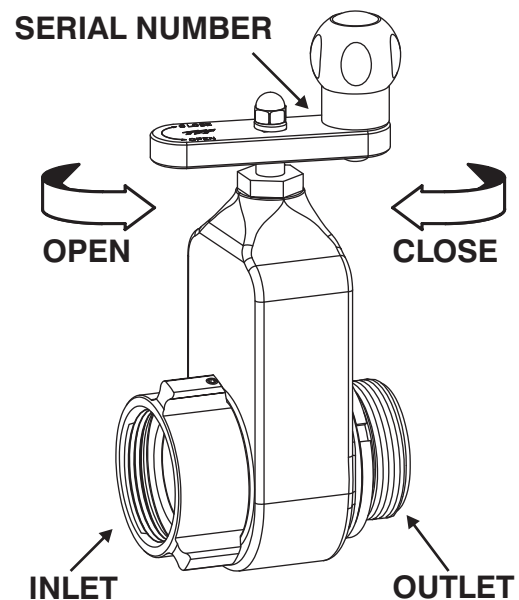

**WARNING** Kinks in supply hose may reduce water flow and cause injury or death to persons dependant on water flow. When this valve is attached directly to a fixed supply, it is recommended that an outlet elbow be used to minimize risk of hoseline kinks.



**CAUTION** Valve must be properly connected. Mismatched or damaged connectors may cause leaking or uncoupling under pressure and could cause injury.



**CAUTION** Valve must be properly connected. Mismatched or damaged connectors may cause leaking or uncoupling under pressure and could cause injury.

## 4.0 DRAWING AND PARTS LIST

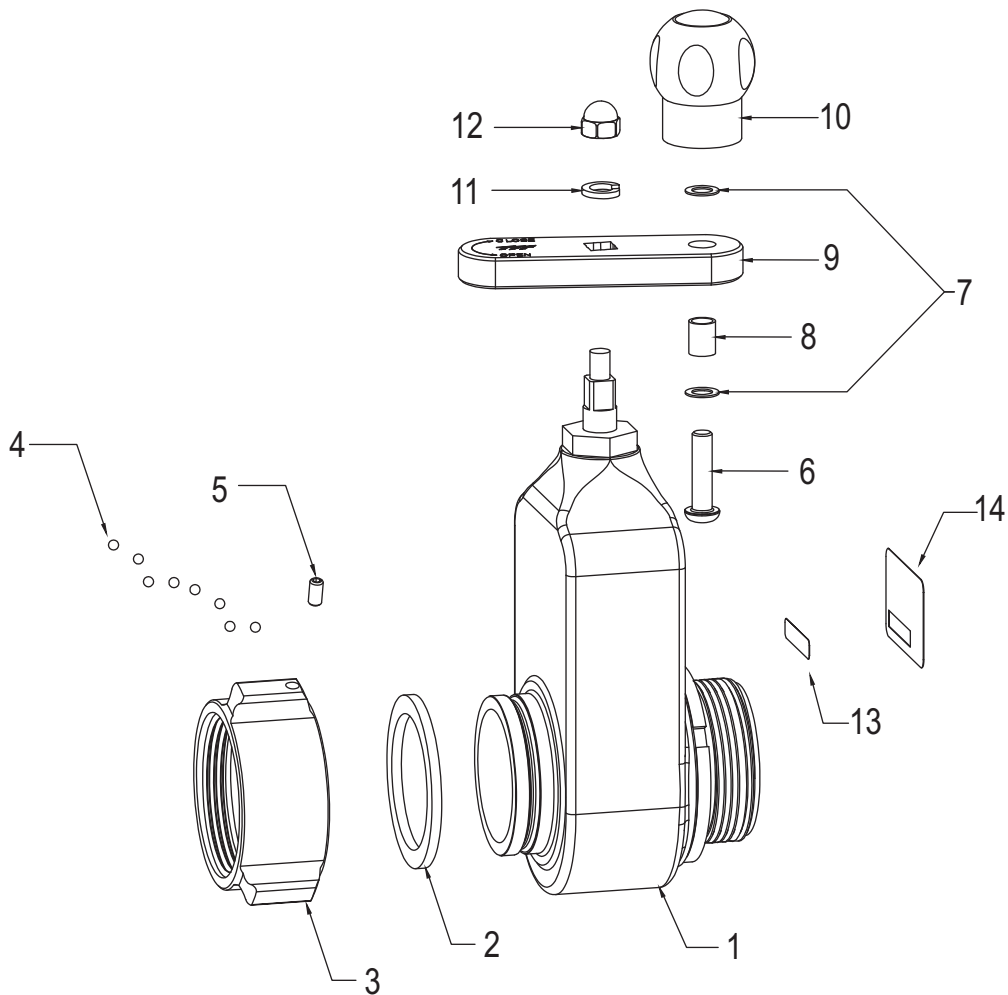

#	Part Description	Part Number	Qty.
1	VALVE BODY W/ 2.5" OUTLET ALUMINUM	A5610A*	1
	VALVE BODY W/ 2.5" OUTLET BRASS	A5610B*	1
2	2.5" GASKET	V3190	1
3	2.5" ROCKERLUG COUPLING ALUMINUM	M307*	1
	2.5" ROCKERLUG COUPLING BRASS	Z307*	1
4	3/16" STAINLESS STEEL BALL	V2120	48
5	1/4-28 X 1/2 SOCKET SET SCREW FOR M307	VT25-28SS500	1
	1/4-28 X 1/2 SOCKET SET SCREW FOR Z307	VT25-28SS750	1
6	3/8-16 X 1-1/2 BUTTON HEAD SCREW	VT37-16BH1.5	1
7	WASHER .630OD X .390ID X .031TH. TEFLON	VW630X390-31	2
8	CRANK BUSHING	A5630	1
9	CRANK	A5620	1
10	KNOB	A1512	1
11	LOCK WASHER	VWM10SSL	1
12	ACORN NUT	VTM10E1.5AC	1
13	MODEL NUMBER LABEL	A1303	1
14	2.5" GATE VALVE NAME LABEL	A1308	1

## 5.0 MAINTENANCE

The valve should be disconnected, cleaned and visually inspected inside and out routinely. Moving parts such as the crank, gate/seat and couplings should be checked for smooth and free operation and greased as needed. A silicone-based grease such as Dow Corning 44 will exclude moisture and retard the effects of corrosion. Any scrapes that expose bare aluminum should be touched up with enamel paint such as Rust-Oleum to inhibit corrosion. Replace any missing or damaged parts before returning the valve to service.

### **CAUTION**

**Dissimilar metals coupled together can cause galvanic corrosion that can result in the inability to unscrew the threads of complete loss of thread engagement over time. Per NFPA 1962 (1998 edition), if dissimilar metals are left coupled together an anti-corrosive lubricant should be applied to the threads. Also the coupling should be disconnected and inspected at least quarterly.**

### **CAUTION**

**Any alterations to the 2.5" Hydrant Gate Valve and its markings could diminish safety and constitutes a misuse of this product.**

## 6.0 WARRANTY

Task Force Tips, Inc., 2800 East Evans Avenue, Valparaiso, Indiana 46383-6940 ("TFT") warrants to the original purchaser of its 2.5" Hydrant Gate Valve ("equipment"), and to anyone to whom it is transferred, that the equipment shall be free from defects in material and workmanship during the five (5) year period from the date of purchase.

TFT's obligation under this warranty is specifically limited to replacing or repairing the equipment (or its parts) which are shown by TFT's examination to be in a defective condition attributable to TFT. To qualify for this limited warranty, the claimant must return the equipment to TFT, at 2800 East Evans Avenue, Valparaiso, Indiana 46383-6940, within a reasonable time after discovery of the defect. TFT will examine the equipment. If TFT determines that there is a defect attributable to it, TFT will correct the problem within a reasonable time. If the equipment is covered by this limited warranty, TFT will assume the expenses of repair.

If any defect attributable to TFT under this limited warranty cannot be reasonably cured by repair or replacement, TFT may elect to refund the purchase price of the equipment, less reasonable depreciation, in complete discharge of its obligations under this limited warranty. If TFT makes this election, claimant shall return the equipment to TFT free and clear of any liens and encumbrances.

This is a limited warranty. The original purchaser of the equipment, any person to whom it is transferred, and any person who is an intended or unintended beneficiary of the equipment, shall not be entitled to recover from TFT any consequential or incidental damages for injury to person and/or property resulting from any defective equipment manufactured or assembled by TFT. It is agreed and understood that the price stated for the equipment is in part consideration for limiting TFT's liability. Some states do not allow the exclusion or limitation of incidental or consequential damages, so the above may not apply to you.

TFT shall have no obligation under this limited warranty if the equipment is, or has been, misused or neglected (including failure to provide reasonable maintenance) or if there have been accidents to the equipment or if it has been repaired or altered by someone else.

**THIS IS A LIMITED EXPRESS WARRANTY ONLY. TFT EXPRESSLY DISCLAIMS WITH RESPECT TO THE EQUIPMENT ALL IMPLIED WARRANTIES OF MERCHANTABILITY AND ALL IMPLIED WARRANTIES OF FITNESS FOR A PARTICULAR PURPOSE. THERE IS NO WARRANTY OF ANY NATURE MADE BY TFT BEYOND THAT STATED IN THIS DOCUMENT.**

This limited warranty gives you specific legal rights, and you may also have other rights which vary from state to state.

**TASK FORCE TIPS, Inc.**  
MADE IN USA • [www.tft.com](http://www.tft.com)

3701 Innovation Way, Valparaiso, IN 46383-9327 USA  
800-348-2686 • 219-462-6161 • Fax 219-464-7155