



MANUAL: *Low Profile Ball Intake Valve*

INSTRUCTIONS FOR INSTALLATION, SAFE OPERATION AND MAINTENANCE



WARNING Understand manual before use. Operation of this device without understanding the manual and receiving proper training is a misuse of this equipment. Obtain safety information at www.tft.com/serial-number

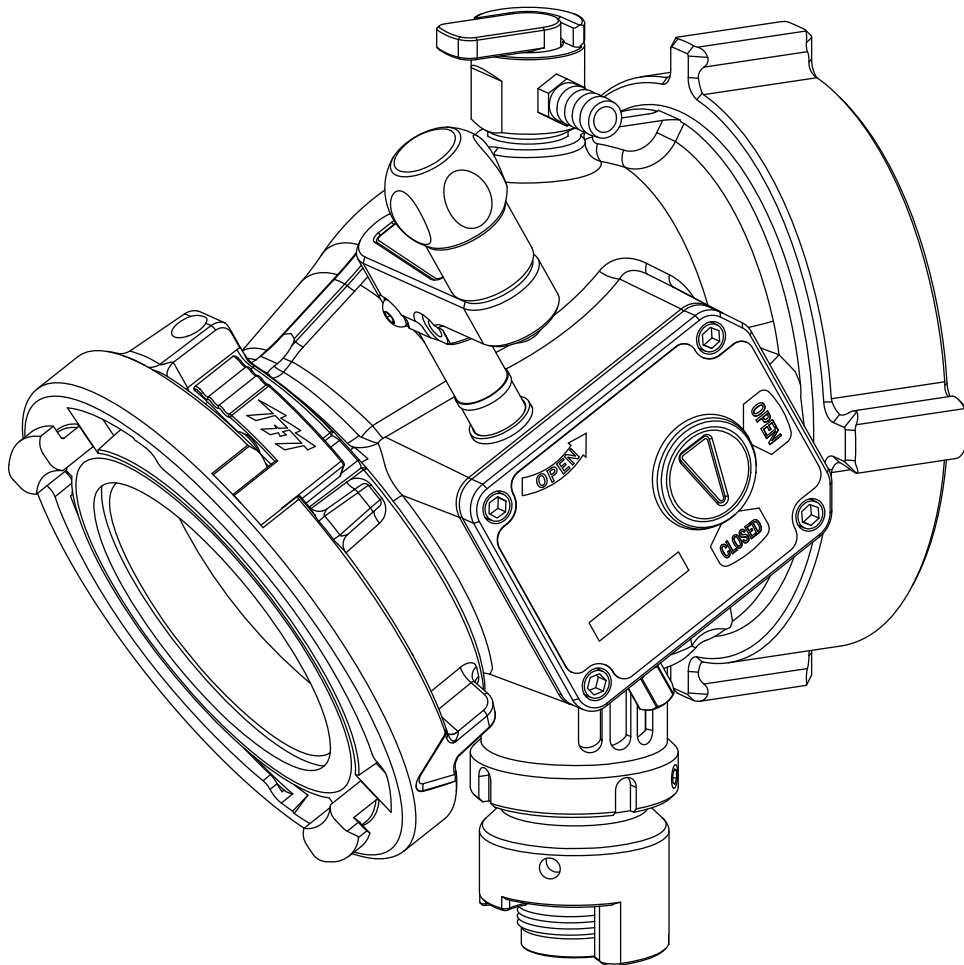

OPERATING RANGE:

Pressure Max 300 PSI (20 bar)
Pressure Min Full Vac.

NFPA 1962 Test Pressure
300 PSI (21 bar)
Six seconds from open to close
meets NFPA 1901
slow close requirement.

TASK FORCE TIPS, INC.
MADE IN USA • www.tft.com

3701 Innovation Way, Valparaiso, IN 46383-9327 USA
800-348-2686 • 219-462-6161 • Fax 219-464-7155



PERSONAL RESPONSIBILITY CODE

The member companies of FEMSA that provide emergency response equipment and services want responders to know and understand the following:

1. Firefighting and Emergency Response are inherently dangerous activities requiring proper training in their hazards and the use of extreme caution at all times.
2. It is your responsibility to read and understand any user's instructions, including purpose and limitations, provided with any piece of equipment you may be called upon to use.
3. It is your responsibility to know that you have been properly trained in Firefighting and /or Emergency Response and in the use, precautions, and care of any equipment you may be called upon to use.
4. It is your responsibility to be in proper physical condition and to maintain the personal skill level required to operate any equipment you may be called upon to use.
5. It is your responsibility to know that your equipment is in operable condition and has been maintained in accordance with the manufacturer's instructions.
6. Failure to follow these guidelines may result in death, burns or other severe injury.



Fire and Emergency Manufacturers and Service Association
P.O. Box 147, Lynnfield, MA 01940 • www.FEMSA.org

Table Of Contents

- 1.0 MEANING OF SIGNAL WORDS
- 2.0 SAFETY
- 3.0 GENERAL INFORMATION
 - 3.1 SPECIFICATIONS
 - 3.2 CORROSION
 - 3.3 USE WITH SALT WATER
- 4.0 INSTALLATION
 - 4.1 MOUNTING THE VALVE
 - 4.2 CHANGING OFFSET OF CRANK HANDLE
 - 4.3 CHANGING COUPLING LOCKOUT
- 5.0 USE
 - 5.1 VALVE POSITION INDICATOR
 - 5.2 STORZ 'SUCTION GASKET' REQUEST
 - 5.3 SUCTION SCREEN
- 6.0 AIR VENT AND WATER DRAIN
- 7.0 PRESSURE RELIEF VALVE
 - 7.1 RELIEF VALVE SETTING PRESSURE
- 8.0 EXPLODED VIEWS AND PARTS LISTS
 - 8.1 BALL INTAKE AXD SERIES EXPLODED VIEW AND PARTS LIST
 - 8.2 SIDE B OPTIONS EXPLODED VIEWS AND PARTS LISTS
 - 8.3 AIR VENT/DRAIN [B] EXPLODED VIEW AND PARTS LIST
 - 8.4 PRESSURE RELIEF VALVE EXPLODED VIEW AND PARTS LIST
- 9.0 TROUBLE SHOOTING
- 10.0 WARRANTY
- 11.0 MAINTENANCE
 - 11.1 SERVICE TESTING
 - 11.1.1 HYDRAULIC TESTING
 - 11.1.2 RELIEF VALVE TEST
 - 11.1.3 SHUTOFF VALVE
 - 11.1.4 RECORDS
 - 11.2 CRANKSHAFT OVERRIDE & REPLACEMENT
 - 11.2.1 CRANKSHAFT OVERRIDE
 - 11.2.2 DIAGNOSIS
 - 11.2.3 CRANKSHAFT REPLACEMENT
- 12.0 REPAIR
- 13.0 BALL INTAKE VALVE PRESSURE LOSS
- 14.0 ANSWERS TO YOUR QUESTIONS
- 15.0 INSPECTION CHECKLIST

1.0 MEANING OF SIGNAL WORDS

A safety related message is identified by a safety alert symbol and a signal word to indicate the level of risk involved with a particular hazard. Per ANSI standard Z535.6-2011, the definitions of the four signal words are as follows:



DANGER indicates a hazardous situation which, if not avoided, will result in death or serious injury.



WARNING indicates a hazardous situation which, if not avoided, could result in death or serious injury.



CAUTION indicates a potentially hazardous situation which, if not avoided, could result in minor or moderate injury.



NOTICE is used to address practices not related to physical injury.

2.0 SAFETY



Quick changes in valve position can cause high pressure spikes due to water hammer and may result in damaged equipment which could lead to injury or death. Open and close the valve slowly to avoid water hammer.



Injury or death can result from burst hoses and fittings. Risk can be minimized by the proper care and use of hose and appliances per NFPA 1962. The relief valve must be set to an appropriate pressure based on the type of hose and equipment you are using.



Injury or death may occur by attempting to use a damaged Valve. Per NFPA 1962, the device shall be inspected and tested at least quarterly. Before use inspect for damage resulting from:

- Failure to drain valve followed by exposure to freezing conditions
- Exposure to temperatures in excess of 160 degrees F
- Missing parts, physical abuse



This equipment is intended for use by trained personnel for firefighting. Its use for other purposes may involve hazards not addressed by this manual. Seek appropriate guidance and training to reduce risk of injury.



Kinks in supply hose may reduce water flow and cause injury or death to persons dependant on water flow. Avoid tight bends to minimize risk of hoseline kinks.



The appliance may be damaged if frozen while containing significant amounts of water. Such damage may be difficult to detect visually and can lead to possible injury or death. Any time the appliance is subject to possible damage due to freezing, it must be hydrostatically tested by qualified personnel before being considered safe for use.



Maximum operating pressure for the valve is 300 PSI (20 bar). Do not exceed 300 PSI on either side of the valve.



Valve must be properly connected. Mismatched or damaged connectors may cause leaking or uncoupling under pressure and could cause injury.



Any alterations to the valve and its markings could diminish safety and constitutes a misuse of this equipment.



Use with salt water is permissible provided the valve is thoroughly cleaned with fresh water after each use. The service life of the valve may be shortened due to the effects of corrosion and is not covered under warranty.

3.0 GENERAL INFORMATION

The Low Profile Ball Intake Valve is intended for use on either the intake manifold of a fire engine or on a discharge port of a fire main. The valve is available in versions to minimize interference with surrounding components. The valve is kept closed while the water supply from a hydrant or another pumper to the engine is being established. This prevents the pump from sucking air through the intake manifold and losing its prime. Once the supply hose is filled and under pressure, and the air has been vented from the hose, the valve may be opened to connect the pump to the water supply. An adjustable pressure relief valve mounted on the valve opens to relieve any excess pressure that may damage the hose or the pump. The valve may be used for pressure or vacuum/drafting service.

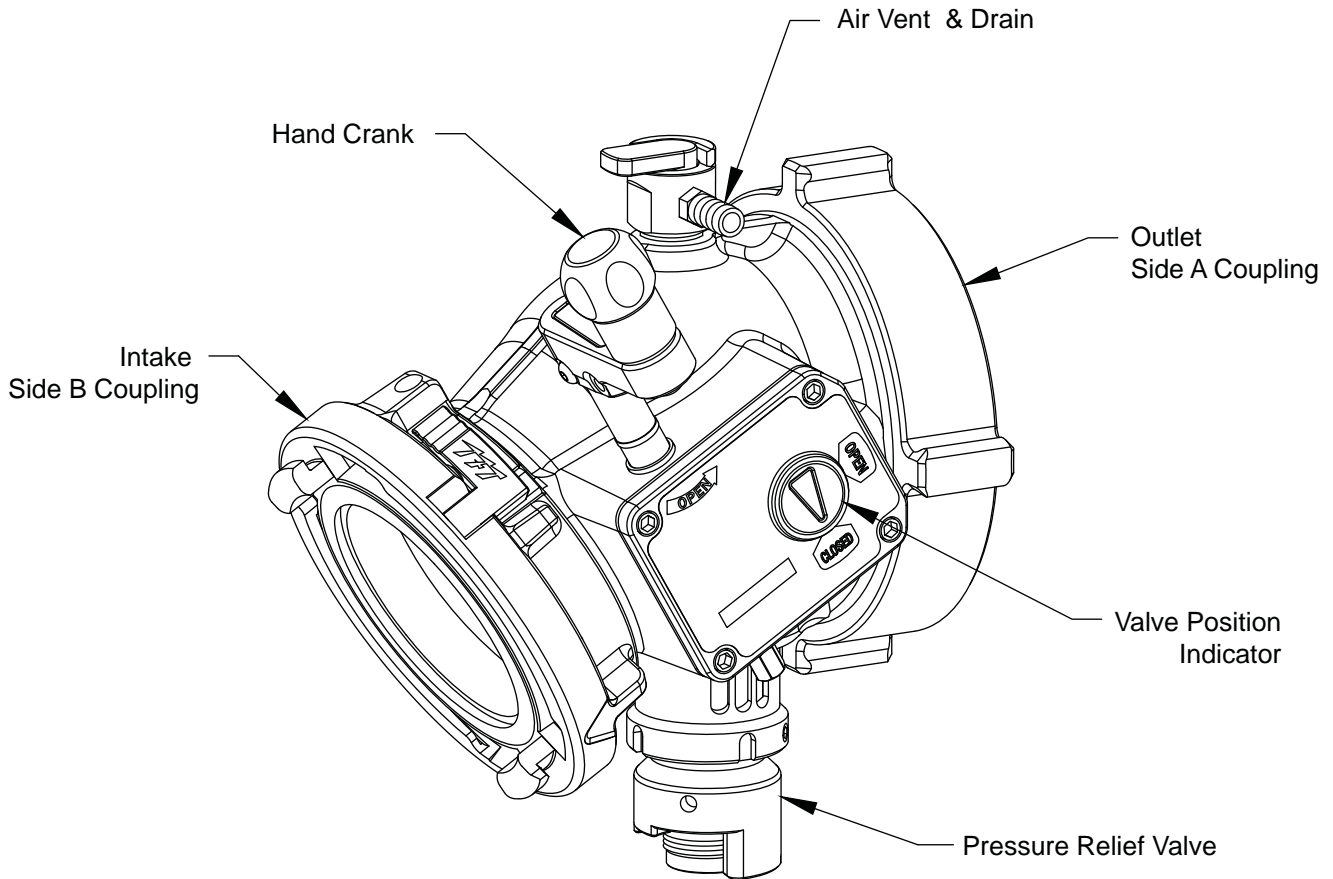

Figure 3.0 AXD3ST-NX
Low Profile Ball Intake Valve
With Pressure Relief Valve

3.1 SPECIFICATIONS

MODEL	LOW PROFILE JUMBO INTAKE VALVE
Waterway Size	3.65" (93mm)
Max Pressure	300 psi (20 bar)
Min Pressure	Full Vacuum
Temperature Rating*	-25°F to 135°F (-32°C to 57°C)
Opening/Closing Speed	Meets NFPA 1965 Slow Close Requirements

3.2 CORROSION

Aluminum parts are hard anodized. All castings are then powder coated inside and out to help prevent corrosion. Hose couplings are attached using polymer bearing rings which provide electrical insulation to help prevent galvanic corrosion. The effects of corrosion can be minimized by good maintenance practice. See section 10.0 for maintenance.

3.3 USE WITH SALT WATER

Use with salt water is permissible provided valve is thoroughly cleaned with fresh water after each use. The service life of the valve may be shortened due to the effects of corrosion and is not covered under warranty.

4.0 INSTALLATION

4.1 MOUNTING THE VALVE

Screw the large coupling to a pump manifold or fire water discharge port and tighten securely. The valve position indicator should be clearly visible, but need not be level.

CAUTION

Dissimilar metals coupled together can cause galvanic corrosion that can result in the inability to unscrew the threads and complete loss of thread engagement over time. Per NFPA 1962 (2013 edition), if dissimilar metals are left coupled together an anti-corrosive lubricant should be applied to the threads. Also, the coupling should be disconnected and inspected at least quarterly.

4.2 CHANGING OFFSET OF CRANK HANDLE

When equipped with a crank handle, two offset positions are available to adjust the swing radius of the crank and knob as shown in figure 3.0. The longer offset position offers reduced effort to operate the valve. The shorter offset is available to avoid interference with other equipment on the apparatus. To change the offset, remove two 1/4"-20 x 1/2" button head cap screws from crank. Place crank in desired position and replace screws. Apply Blue Loc-Tite thread locking compound to all of the screw threads.

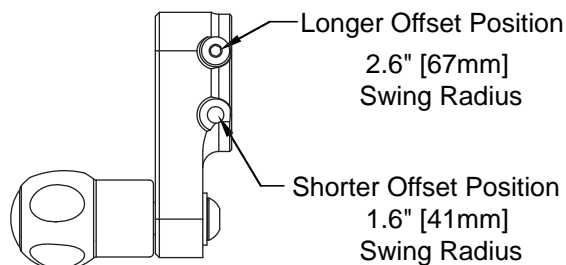

Figure 4.2
Crank Handle Offset

4.3 CHANGING COUPLING LOCK-OUT

To change a coupling from rigid to full time swivel, use a 7/32" Allen driver to back out the lockout screw until the coupling moves freely.

To change a coupling from full time swivel to rigid, Rotate the coupling until the lockout screw is aligned with the Air Vent/Bleed Valve on the top of the valve body. Use a 7/32" Allen driver to tighten the lockout screw into the lockout divot in the elbow. Do not tighten the screw onto the polymer bearing strip.

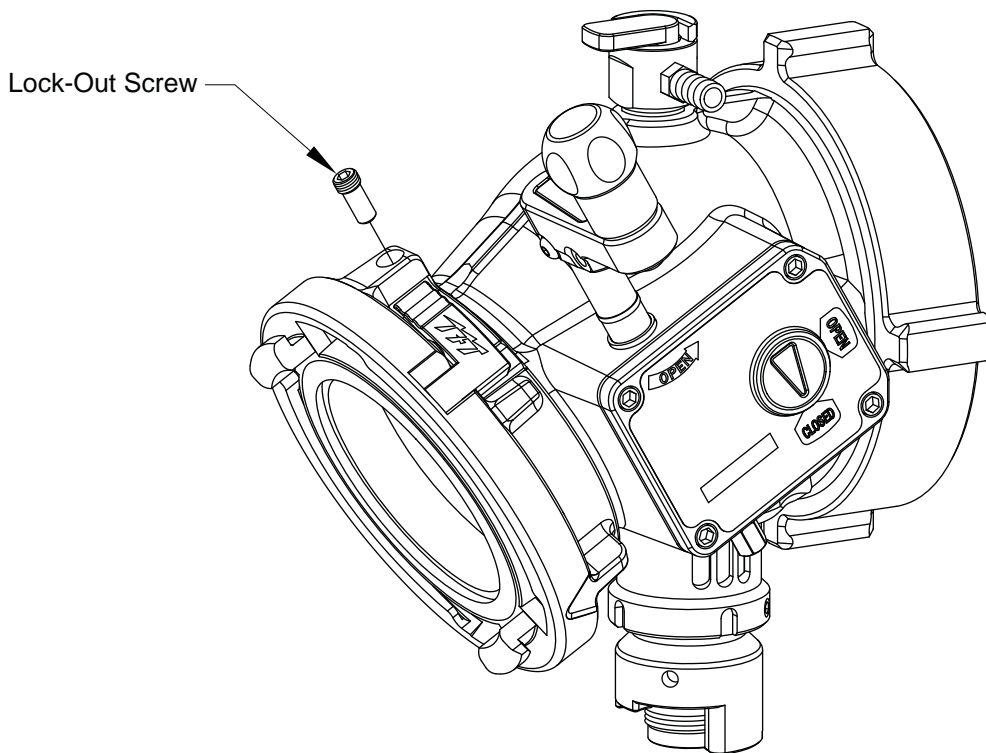

Figure 4.3.
Coupling Lock-Out

5.0 USE

5.1 VALVE POSITION INDICATOR

The valves covered by this manual utilize positive stops at open and close. Attempting to close a valve further than the positive stop will not result in a tighter seal between the ball and valve seat. Up to the maximum rated pressure of 300 psi, operating torque should never exceed the values in the table below. If greater torque is required to operate the valve, then that is an indication that the valve needs maintenance. Exceeding 30 ft-lb torque (137 lb applied to the knob) may damage components in the gearbox. Kicking or standing on the valve controls is considered misuse of the product.

Valve Seat Bore Size		Max Acceptable Torque		Max. Acceptable Force on Knob	
3.65 in	93mm	12 ft-lb	16 N-m	55 lb	25 kg

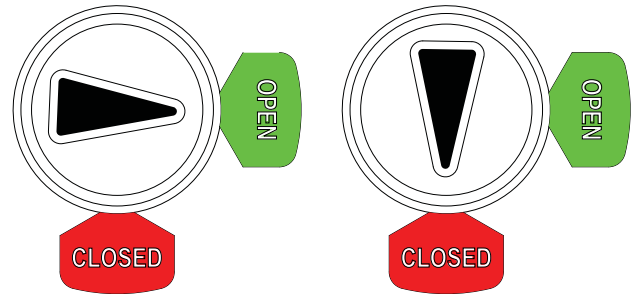

Figure 5.1
Valve Position Indicator

Exceeding 45 ft-lb will cause one side of the crank shaft to shear off. This is intentional to prevent further damage to the gearbox. If the shaft shears off, the valve can be operated temporarily using a wrench on the 1/2" hex on the opposite side of the crankshaft. For repair instructions, see section 10.3 CRANKSHAFT OVERRIDE AND REPLACEMENT.

5.2 STORZ 'SUCTION GASKET' REQUEST

If your application of this product requires drafting, you may need a suction gasket. Please call 1-800-348-2686 to receive a free suction gasket by mail.

Part Numbers: 4" STORZ - item # A4216, 5" STORZ - item # A4221, 6" STORZ - item #A4273

5.3 SUCTION SCREEN

This device may be equipped with a suction screen to catch debris larger than 3/8" diameter in the waterway. See chart to determine additional loss caused by the screen. To add or replace a suction screen, order TFT part #A1410-KIT for the 4.5" waterway, and TFT part #A1411-KIT for the 5.0" waterway. See Section 13.0 for suction screen pressure loss.

6.0 AIR VENT AND WATER DRAIN

CAUTION Loss of prime can interrupt water flow and cause injury or death. Always bleed out air with air valve to prevent possible loss of prime.

The BIV-LP comes with an Air Vent/Drain Valve situated on the top of the valve.

7.0 PRESSURE RELIEF VALVE

WARNING Do not leave the pressure relief valve in the OFF position. The pressure relief valve is disabled in the OFF position and offers no protection against over pressurization. The OFF position may be used for controlled pump testing but should not be used for service conditions. Exercise great care to avoid water hammer or other pressure spikes when the pressure relief valve is in the OFF position.

LDH valved appliances may be equipped with a pressure relief valve that can be set to any pressure between 90 and 300 psi. Its function is to protect the pump and supply hose from excess pressure.

See **LIA-202** Pressure Relief Valve Instructions for Safe Operation and Maintenance.

7.1 RELIEF VALVE SETTING PRESSURE

To set the relief valve pressure turn the adjusting screw on the relief valve housing until the surface of the screw is even with the desired pressure. A 9/16" (14mm) socket or a 1/4" Allen wrench may be used to turn the adjusting screw. The Pressure relief valve should not be disabled (IE: capped, plugged, or set to the OFF position) for normal service conditions. Disabling the relief valve may result in system damage or hose rupture if the system exceeds operating limits. The pressure relief valve meets the requirements of NFPA 1901.

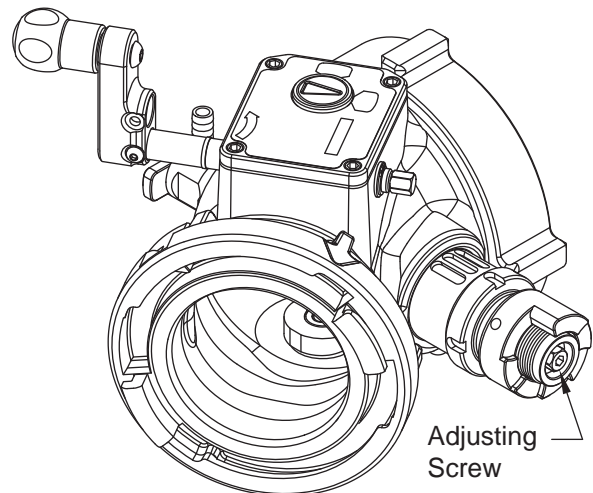
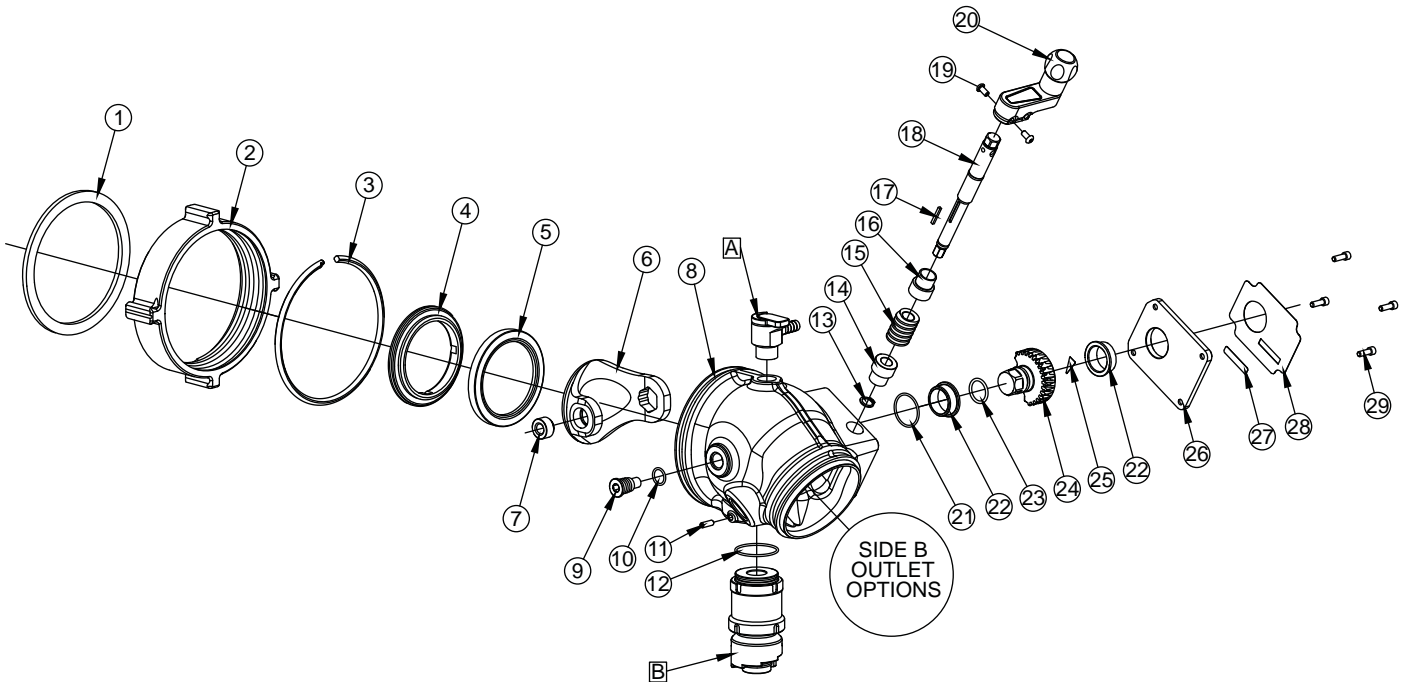

Figure 7.1
Pressure Relief Valve

8.0 EXPLODED VIEWS AND PARTS LISTS

8.1 BALL INTAKE VALVE - EXPLODED VIEW AND PARTS LIST



INDEX	DESCRIPTION	QTY	PART #
1	GASKET - 6.0"	1	V3240
	GASKET - 5.0"		V3220
2	COUPLING RL 6.0"NHF X PSF7.0-NFS	1	A4674NX
	COUPLING RL 5.0"NHF X PSF7.0-NFS		A4671NT
3	PLASTIC STRIP 7.00"	1	A1290
4	RETAINING RING	1	A1521A
5	VALVE SEAT	1	A1520
6	HALF BALL 5.5" ALUM NO DRAIN	1	A1043A
7	BUSHING	1	A2095
8	BODY LOW PROFILE	1	A1016
9	LOWER TRUNNION	1	AY357
10	O-RING-115	1	VO-115
11	1/4-20 X 1/2 SOCKET SET SCREW	1	VT25-20SS500
12	O-RING-135	1	VO-135
13	RETAINING RING 15MM EXTERNAL	1	VR4275
14	THRUST WASHER/SMALL BUSHING	1	A1536
15	12 DP WORM	1	X220
16	THRUST WASHER/LARGE BUSHING	1	A1537
17	KEY	1	X225
18	CRANK SHAFT	1	A1533
19	1/4-20 X 1/2 BUTTON HEAD SCREW	2	VT25-20BH500
20	CRANK WITH KNOB SUBASSEMBLY	1	A1623
21	O-RING-128	1	VO-128
22	BUSHING	2	A1538
23	O-RING-214	1	VO-214
24	INTEGRAL WORM GEAR AND TRUNNION	1	A1504
25	INDICATOR LABEL	1	A1508
26	GEARBOX COVER	1	A1507
27	MODEL NUMBER LABEL	1	A1303
28	LABEL LOW PROFILE BIV	1	A1315
29	1/4-20 X 3/4 SOCKET HEAD SCREW	4	VT25-20SH750
A	DRAIN VALVE SUBASSEMBLY	1	SEE SECTION 8.3
B	PRESSURE RELIEF VALVE SUBASSEMBLY	1	SEE SECTION 8.4

8.2 SIDE B OPTIONS EXPLODED VIEWS AND PARTS LISTS

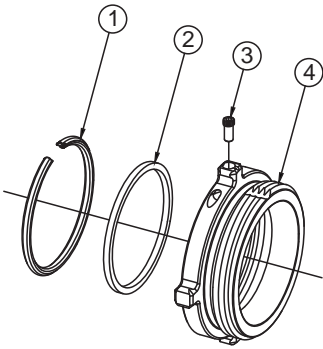

MALE HOSE THREADS						
INDEX	DESCRIPTION	QTY	4.0"	4.5"	5.0"	6.0"
1	PLASTIC STRIP	1	A1291	A1291	A1291	A1291
2	CUP SEAL	1	A1596	A1596	A1596	A1596
3	LOCK-OUT SCREW	1	A1294	A1294	A1294	A1294
4	SPOUT	1	A4620N	A4625N	A4630N	A4635N

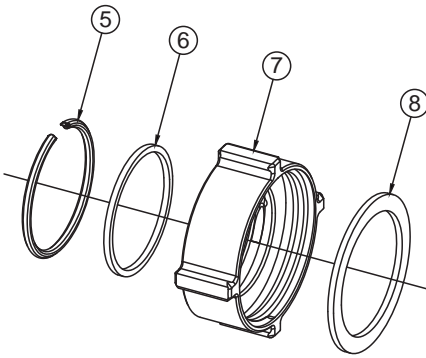

FEMALE HOSE THREADS ROCKER LUG							
INDEX	DESCRIPTION	QTY	3.5"	4.0"	4.5"	5.0"	6.0"
5	PLASTIC STRIP	1	A1292	A1291	A1291	A1291	A1290
6	CUP SEAL/O-RING	1	A1597	A1596	A1596	A1596	-
7	COUPLING	1	A4665N	A4660N	A4665N	A4670N	A4674NX
8	GASKET	1	V3196	V3198	V3210	V3220	V3240
-	NFS RING/O-RING	1	-	-	-	-	-
-	MATE	1	A4730	-	-	-	A4730
-	PLASTIC STRIP	1	A1291	-	-	-	A1291
-	CUP SEAL	1	A1596	-	-	-	A1596
-	BALL	1	VB.437	-	-	-	-

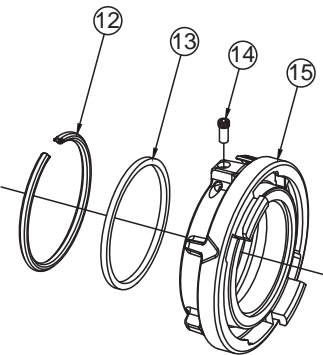

STORZ					
INDEX	DESCRIPTION	QTY	4.0"	5.0"	6.0"
12	PLASTIC STRIP	1	A1292	A1291	A1291
13	CUP SEAL	1	A1597	A1596	A1596
14	LOCK-OUT SCREW	1	A1294	A1294	VB.437
15	COUPLING	1	A4124	A4125	A4289
-	MATE	1	A4730	-	-
-	PLASTIC STRIP	1	A1291	-	-
-	CUP SEAL	1	A1596	-	-
-	BALL	1	VB.437	-	-

8.3 AIR VENT/DRAIN [A] EXPLODED VIEW AND PARTS LIST

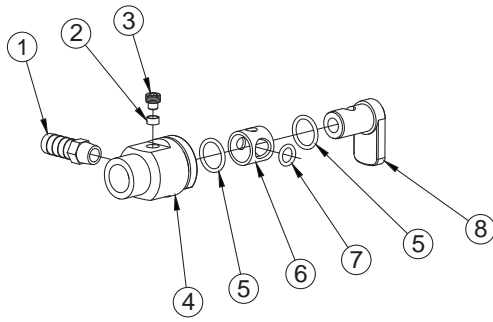

Replacement Kit - A1621-KIT

ITEM	DESCRIPTION	QTY	PART #
1	1/2" BARB X 1/4"NPTM NIPPLE	1	XX329
2	FOLLOWER	1	U251
3	3/8-24 X 3/8 DOG POINT	1	H515
4	DRAIN HOUSING	1	A1543
5	O-RING 115	2	VO-115
6	DRAIN SLEEVE	1	A1541
7	O-RING-110	1	VO-110
8	DRAIN LEVER	1	A1542

8.4 PRESSURE RELIEF VALVE [B] EXPLODED VIEW AND PARTS LIST

NOTICE

The Pressure Relief Valve contains no user serviceable components. If disassembled, the unit must be returned to the factory for service and calibration.

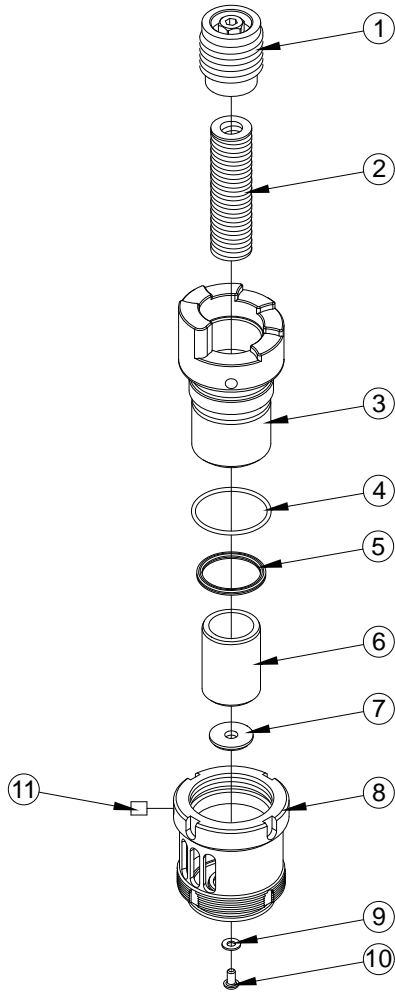

ITEM	DESCRIPTION	QTY	PART #
1	ADJUSTING SCREW	1	A1122
2	RELIEF SPRING	1	A1172
3	SPRING HOUSING	1	A1125
4	O-RING-131	1	VO-131
5	QUAD-RING-220	1	VOQ-4220
6	PISTON	1	A1120
7	GASKET	1	A1121
8	PRV TURNED HOUSING	1	A1115
9	WASHER	1	VW437X203-03
10	10-24 X 1/2 BUTTON HEAD SCREW	1	VT10-24BH500
11	5/16-18 X 3/8 SOCKET SET SCREW	1	VT31-18SS375

9.0 TROUBLE SHOOTING

SYMPTOM	POSSIBLE CAUSE	REMEDY
Leaks	Debris or damage in seal area	Clean out debris or replace damaged parts

10.0 WARRANTY

Task Force Tips, Inc., 3701 Innovation Way, Valparaiso, Indiana 46383-9327 USA (“TFT”) warrants to the original purchaser of its Low Profile Ball Intake Valve (“equipment”), and to anyone to whom it is transferred, that the Low Profile Intake Valve series includes a 5 year warranty against manufacturing defects and corrosion affecting the valve’s operational performance.

TFT’s obligation under this warranty is specifically limited to replacing or repairing the equipment (or its parts) which are shown by TFT’s examination to be in a defective condition attributable to TFT. To qualify for this limited warranty, the claimant must return the equipment to TFT, at 3701 Innovation Way, Valparaiso, Indiana 46383-9327 USA, within a reasonable time after discovery of the defect. TFT will examine the equipment. If TFT determines that there is a defect attributable to it, TFT will correct the problem within a reasonable time. If the equipment is covered by this limited warranty, TFT will assume the expenses of repair.

If any defect attributable to TFT under this limited warranty cannot be reasonably cured by repair or replacement, TFT may elect to refund the purchase price of the equipment, less reasonable depreciation, in complete discharge of its obligations under this limited warranty. If TFT makes this election, claimant shall return the equipment to TFT free and clear of any liens and encumbrances.

This is a limited warranty. The original purchaser of the equipment, any person to whom it is transferred, and any person who is an intended or unintended beneficiary of the equipment, shall not be entitled to recover from TFT any consequential or incidental damages for injury to person and/or property resulting from any defective equipment manufactured or assembled by TFT. It is agreed and understood that the price stated for the equipment is in part consideration for limiting TFT’s liability. Some states do not allow the exclusion or limitation of incidental or consequential damages, so the above may not apply to you.

TFT shall have no obligation under this limited warranty if the equipment is, or has been, misused or neglected (including failure to provide reasonable maintenance) or if there have been accidents to the equipment or if it has been repaired or altered by someone else.

THIS IS A LIMITED EXPRESS WARRANTY ONLY. TFT EXPRESSLY DISCLAIMS WITH RESPECT TO THE EQUIPMENT ALL IMPLIED WARRANTIES OF MERCHANTABILITY AND ALL IMPLIED WARRANTIES OF FITNESS FOR A PARTICULAR PURPOSE. THERE IS NO WARRANTY OF ANY NATURE MADE BY TFT BEYOND THAT STATED IN THIS DOCUMENT.

This limited warranty gives you specific legal rights, and you may also have other rights which vary from state to state.

11.0 MAINTENANCE

TFT appliances are designed and manufactured to be damage resistant and require minimal maintenance. However, as the primary firefighting tool upon which your life depends, it should be treated accordingly. Do not drop or throw equipment.

This valve should be disconnected, cleaned and visually inspected inside and out at least quarterly for proper function per NFPA 1962 section 8.2, or as water quality and use may require. Moving parts such as handles, valve ball and couplings should be checked for smooth and free operation. Seals shall be greased as needed with a silicone-based grease such as Dow Corning 112. Any scrapes that expose bare aluminum should be cleaned and touched up with enamel paint such as Rust-Oleum. Replace any missing or damaged parts before returning to service. Any repaired device must be tested before being placed in service.

11.1 SERVICE TESTING

In accordance with NFPA 1962 (2013), appliances must be tested a minimum of annually. Appliances failing any part of this test must be removed from service, repaired and retested upon completion of the repair.

11.1.1 HYDRAULIC TEST

1. The appliance being tested shall be positioned in a protective device or cover capable of holding the appliance and tested to a minimum hydrostatic pressure of 300 psi (20.7 bar or 2070 kPa).
2. Test caps capable of withstanding the required hydrostatic pressure shall be attached to openings, and a device capable of exerting the required hydrostatic pressure shall be attached to the appliance.
3. Appliances with relief valves shall have the relief valve outlet blanked off or otherwise closed during the test.
4. All air shall be bled from the system.
5. The gauge pressure shall be increased by 50 psi (3.45 bar or 345 kPa) increments and held for 30 seconds at each pressure up to the maximum pressure for which the appliance is being tested and held for 1 minute without leakage.

11.1.2 RELIEF VALVE TEST

1. Hydrostatic testing of the appliance shall be conducted prior to testing the relief valve.
2. The relief valve shall be tested separately from any device it is connected to.
3. The relief valve shall be set to its lowest setting and pressurized.
4. If the relief valve does not operate at or below a pressure 10 percent over the setting, the test shall be discontinued and the relief valve repaired or replaced.
5. A calibrated test gauge shall be used to verify the setting.
6. After successful completion of the relief valve test, the relief valve shall be reset to the pressure designated by the authority having jurisdiction.
7. The final setting of the relief valve shall be confirmed by pressure testing.

11.1.3 SHUTOFF VALVE TEST

1. If the appliance has a shutoff valve, the intake side of the shutoff valve shall be hydrostatically pressurized to the maximum working pressure of the appliance with the valve in the shutoff position.
2. There shall be no leakage through the valve.
3. A water flow through the fire hose appliance at 100 psi (6.9 bar or 690 kPa) shall be established.
4. The valve shall be closed and reopened twice and shall operate smoothly without evidence of binding or other problems.

11.1.4 RECORDS

A record of testing and repairs must be maintained from the time the appliance is purchased until it is discarded. Each TFT appliance is engraved with a unique serial number which, if so desired, can be used to identify appliance for documentation purposes.

The following information, if applicable, must be included on the test record for each appliance:

1. Assigned identification number
2. Manufacturer
3. Product or model designation
4. Vendor
5. Warranty
6. Hose connection size
7. Maximum operating pressure
8. Flow rate or range
9. Date received and date put in service
10. Date of each service test and service test results
11. Damage and repairs, including who made the repairs and the cost of repair parts
12. Reason removed from service

11.2 CRANKSHAFT OVERRIDE AND REPLACEMENT

The crankshaft includes an intentional shear joint to protect the gear train from overload, costly repairs, and loss of service. The magnitude of torque required to shear the crankshaft is several times greater than the torque typically needed to operate the valve at maximum operating pressure. If the crankshaft breaks during use, this is an indication that either there is something obstructing the half ball internally or the crank shaft has been abused (e.g. used as a step for climbing).

11.2.1 CRANKSHAFT OVERRIDE

In an emergency, the opposite side of the crankshaft can be turned using a 1/2" wrench or hex socket. This allows the valve to be open or closed until the crankshaft is replaced. To prevent loss of the 1/8" square key on the crankshaft, do not allow the crankshaft to slide out of gearbox until a replacement crankshaft is acquired. It is important not to rely on this as a long-term method of operation.

11.2.2 DIAGNOSIS

To diagnose the problem that caused the crankshaft to fail, complete the following steps:

1. Close upstream water supply. If possible, relieve pressure leading up to valve.
2. Locate 1/2" hex where crankshaft protrudes from opposite side of gearbox.
3. Gently turn crank shaft away from travel stop using a 1/2" hex wrench. Do not attempt to shock crankshaft free and do not exceed 50 ft-lb (68 Nm) of torque.
4. If crankshaft will not rotate, then half ball is likely obstructed. Only after relieving pressure on flanged joint, unbolt valve. Clear any obstructions and evaluate whether repair is needed before returning to service.
5. If crankshaft is able to rotate, cycle the valve several times from open to closed to determine whether the crankshaft binds at any place between the travel stops. If crankshaft binds, consult Task Force Tips Service Department to determine the appropriate repairs.
6. If crankshaft rotates freely after clearing any obstructions, then a replacement crank shaft may be ordered from Task Force Tips and replaced as described below.

11.2.3 CRANKSHAFT REPLACEMENT

A broken crankshaft can be replaced at any time by completing the following steps, regardless of whether or not the upstream water supply is pressurized. Referring to index numbers shown in section 8.3, follow the steps below:

1. Remove external retaining ring (index 13) adjacent to 1/2" hex on crankshaft.
2. Using a punch or Phillips head screwdriver at least 6" in length, gently push on dimple in 1/2" hex end of crankshaft (index 18). Continue to push crankshaft through until it protrudes from opposite side of gearbox.
3. Grab broken end of crankshaft and pull out of gearbox. As crankshaft is withdrawn, grasp small key (index 17) on shaft so it does not get lost.

4. If 1/8" square x 1" long key is not visible in shaft, it has likely fallen into gearbox bore and must be removed before installing new crankshaft. If square key is visible in gearbox bore, slide it out of bore. Needle-nose pliers may be helpful depending on position of key in bore.
5. Verify polymer bushings/thrust washers (index 16 and 14) are still seated in bores on each side of gearbox. If not, locate and replace bushings.
6. Look through gearbox bore and note approximate orientation of square keyway in worm (index 15). Verify round notch in polymer bushings/thrust washers (index 16) is aligned with square keyway in worm.
7. Prepare new crankshaft by applying small dab of grease to keyway and seating 1/8" square x 1" long key into keyway. Grease will keep key in place during assembly.
8. Slide shaft into gearbox with key orientation the same as keyway in worm. Rotate shaft slightly in alternating directions until key finds keyway, then push shaft in until it stops. Retaining ring groove and 1/2" hex should be protruding through opposite side of gearbox. If hex is not visible, it may be necessary to slide polymer bushing back into gearbox bore.
9. Install retaining ring (index 13) onto shaft. Do not over-expand the retaining ring.

12.0 REPAIR

Factory service is available with repair time seldom exceeding one day in our facility. Factory serviced appliances are repaired by experienced technicians to original specifications, fully tested and promptly returned. Repair charges for non-warranty items are minimal. Any returns should include a note as to the nature of the problem and whom to reach in case of questions.

Repair parts and service procedures are available for those wishing to perform their own repairs. Task Force Tips assumes no liability for damage to equipment or injury to personnel that is a result of user service. Contact the factory or visit the web site at www.tft.com for parts lists, exploded views, test procedures and troubleshooting guides.

For additional information on care, maintenance and testing, refer to: NFPA 1962: Standard for the Care, Use, Inspection, Service Testing, and Replacement of Fire Hose, Couplings, Nozzles, and Fire Hose Appliances, 2013 Edition

CAUTION Any alterations to the device and its markings could diminish safety and constitute a misuse of this product.

13.0 BALL INTAKE VALVE PRESSURE LOSS

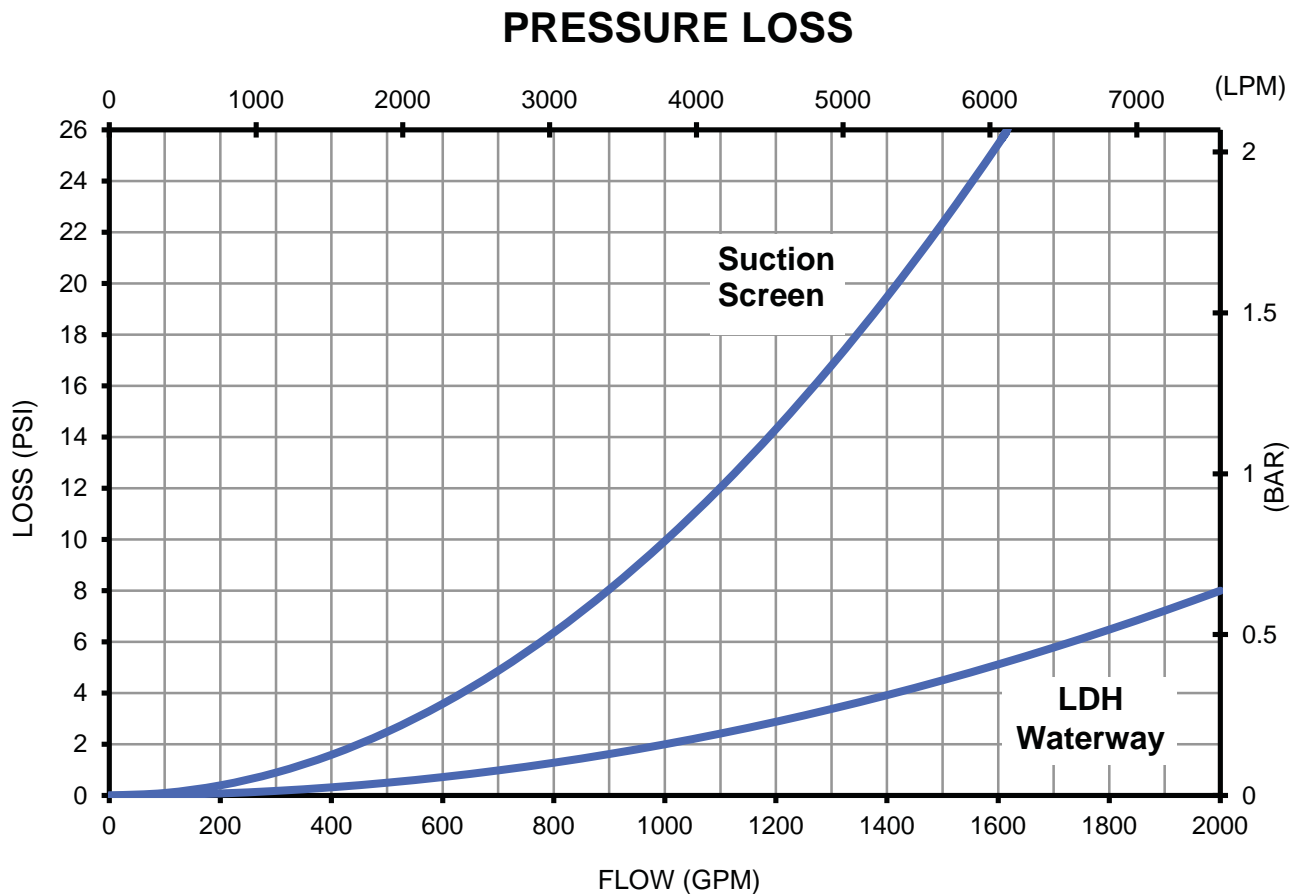

Figure 13.0
Pressure Loss Chart

14.0 ANSWERS TO YOUR QUESTIONS

We appreciate the opportunity of serving you and making your job easier. If you have any problems or questions, our toll-free "Hydraulics Hotline", 800-348-2686, is normally available to you 24 hours a day, 7 days a week.

15.0 INSPECTION CHECKLIST

Appliances must be inspected for proper operation and function according to this checklist before each use. Before flowing water check:

- Valve opens and closes fully and smoothly
- Waterway is clear of obstructions
- There is no damage to any thread or other connection
- The pressure setting on the relief valve (if so equipped) is set correctly
- Gaskets are in good repair
- There is no damage to the appliance that could impair safe operation (e.g. dents, cracks, corrosion or other defects)
- All swiveling elements rotate freely
- There are no missing, worn out or broken lugs on couplings
- Hose is securely attached



Any valve failing any part of the inspection checklist is unsafe and must have the problem corrected before use. Operating a valve that fails any of the above inspections is a misuse of this equipment.