

MANUAL: *Jumbo Low Profile Ball Intake Valve*

INSTRUCTIONS FOR INSTALLATION, SAFE OPERATION AND MAINTENANCE

⚠ WARNING

Understand manual before use. Operation of this device without understanding the manual and receiving proper training is a misuse of this equipment. Obtain safety information at www.tft.com/serial-number

LEFT DRIVE

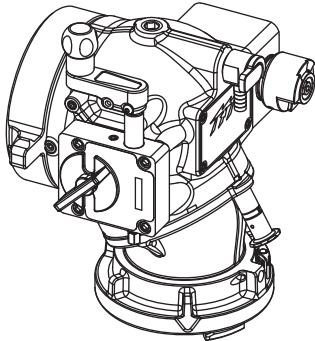

AXD1ST-NX-T
Jumbo Low Profile
Ball Intake Valve
Top Crank
With Pressure Relief Valve

AZD1ST-NX-T
Without Pressure Relief Valve
(not shown)

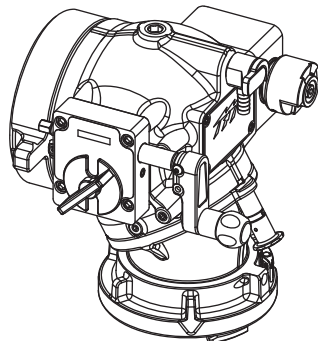

AXD1ST-NX-F
Jumbo Low Profile
Ball Intake Valve
Front Crank
With Pressure Relief Valve

AZD1ST-NX-F
Without Pressure Relief Valve
(not shown)

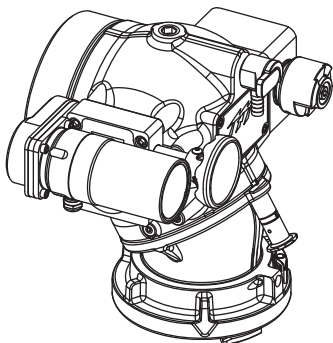

AXD1ST-NX-RC
Jumbo Low Profile
Ball Intake Valve
Electrically Actuated
With Pressure Relief Valve

AZD1ST-NX-RC
Without Pressure Relief Valve
(not shown)

RIGHT DRIVE

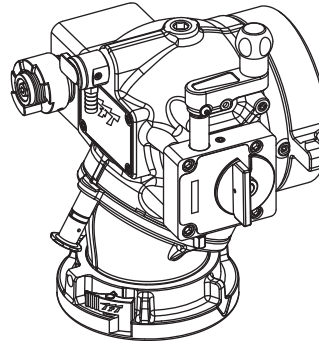

AXE1ST-NX-T
Jumbo Low Profile
Ball Intake Valve
Top Crank
With Pressure Relief Valve

AZE1ST-NX-T
Without Pressure Relief Valve
(not shown)

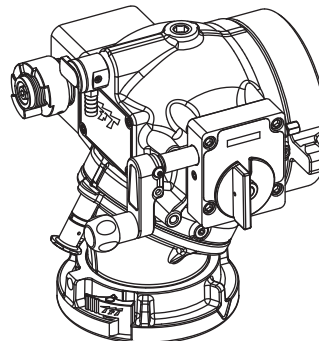

AXE1ST-NX-F
Jumbo Low Profile
Ball Intake Valve
Front Crank
With Pressure Relief Valve

AZE1ST-NX-F
Without Pressure Relief Valve
(not shown)

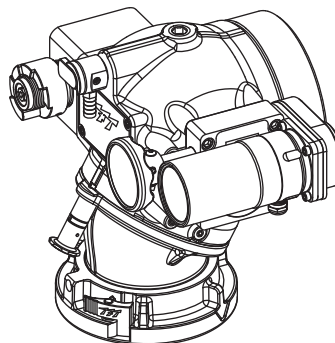

AXE1ST-NX-RC
Jumbo Low Profile
Ball Intake Valve
Electrically Actuated
With Pressure Relief Valve

AZE1ST-NX-RC
Without Pressure Relief Valve
(not shown)

Table Of Contents

1.0	MEANING OF SIGNAL WORDS	7.0	TROUBLE SHOOTING
2.0	SAFETY	8.0	TEN YEAR EXTENDED WARRANTY FOR JBIV-LP SERIES VALVES
3.0	GENERAL INFORMATION	9.0	MAINTENANCE
3.1	SPECIFICATIONS	9.1	SERVICE TESTING
3.2	CORROSION	9.1.1	HYDRAULIC TESTING
3.3	USE WITH SALT WATER	9.1.2	RELIEF VALVE TEST
4.0	INSTALLATION	9.1.3	SHUTOFF VALVE
4.1	MOUNTING THE VALVE	9.1.4	RECORDS
4.2	ENCLOSURE MOUNTING	9.2	CRANKSHAFT OVERRIDE & REPLACEMENT
4.3	ELECTRIC INSTALLATION AND WIRING	9.2.1	CRANKSHAFT OVERRIDE
4.4	ELECTRICAL TESTING	9.2.2	DIAGNOSIS
4.5	BALL INTAKE VALVE RC MANUAL OVERRIDE	9.2.3	CRANKSHAFT REPLACEMENT
4.6	CHANGING OFFSET OF CRANK HANDLE	10.0	REPAIR
4.7	CHANGING COUPLING LOCKOUT	11.0	ANSWERS TO YOUR QUESTIONS
4.8	PEG	12.0	TEMPLATES
4.9	STORZ 'SUCTION GASKET' REQUEST	13.0	INSPECTION CHECKLIST
5.0	USE		
5.1	ELBOW		
5.2	VALVE OPERATION		
5.3	BALL INTAKE VALVE RC OPERATION		
5.4	AIR VENT AND WATER DRAIN		
5.5	PRESSURE RELIEF VALVE		
5.5.1	RELIEF VALVE SETTING PRESSURE		
5.6	PRESSURE LOSS		
5.7	SUCTION SCREEN		
6.0	EXPLODED VIEWS AND PARTS LISTS		
6.1	JUMBO BALL INTAKE AXD SERIES EXPLODED VIEW AND PARTS LIST		
6.2	MOTOR ASSEMBLY JUMBO LOW PROFILE BIV RC PARTS LIST		
6.3	SIDE B OPTIONS EXPLODED VIEWS AND PARTS LISTS		
6.4	WORM DRIVE GEARBOX [A] EXPLODED VIEW AND PARTS LIST		
6.5	AIR VENT/DRAIN [B] EXPLODED VIEW AND PARTS LIST		

OPERATING RANGE:

For Jumbo Ball Intake Valves
Pressure Max 250 PSI (17 bar)
Pressure Min Full Vac.

NFPA 1962 Test Pressure
300 PSI (21 bar)
Six seconds from open to close
meets NFPA 1901
slow close requirement.



PERSONAL RESPONSIBILITY CODE

The member companies of FEMSA that provide emergency response equipment and services want responders to know and understand the following:

1. Firefighting and Emergency Response are inherently dangerous activities requiring proper training in their hazards and the use of extreme caution at all times.
2. It is your responsibility to read and understand any user's instructions, including purpose and limitations, provided with any piece of equipment you may be called upon to use.
3. It is your responsibility to know that you have been properly trained in Firefighting and /or Emergency Response and in the use, precautions, and care of any equipment you may be called upon to use.
4. It is your responsibility to be in proper physical condition and to maintain the personal skill level required to operate any equipment you may be called upon to use.
5. It is your responsibility to know that your equipment is in operable condition and has been maintained in accordance with the manufacturer's instructions.
6. Failure to follow these guidelines may result in death, burns or other severe injury.



Fire and Emergency Manufacturers and Service Association
P.O. Box 147, Lynnfield, MA 01940 • www.FEMSA.org

1.0 MEANING OF SIGNAL WORDS

A safety related message is identified by a safety alert symbol and a signal word to indicate the level of risk involved with a particular hazard. Per ANSI standard Z535.6-2011, the definitions of the four signal words are as follows:



DANGER indicates a hazardous situation which, if not avoided, will result in death or serious injury.



WARNING indicates a hazardous situation which, if not avoided, could result in death or serious injury.



CAUTION indicates a potentially hazardous situation which, if not avoided, could result in minor or moderate injury.



NOTICE is used to address practices not related to physical injury.

2.0 SAFETY



Do not use AC voltage to operate the RC valve. The RC valve is a 12 or 24VDC system **ONLY!** Using the wrong power source could cause electrocution, resulting in death or serious injury.



Quick changes in valve position can cause high pressure spikes due to water hammer and may result in damaged equipment which could lead to injury or death. Open and close the valve slowly to avoid water hammer.



Injury or death can result from burst hoses and fittings. Risk can be minimized by the proper care and use of hose and appliances per NFPA 1962. The relief valve must be set to an appropriate pressure based on the type of hose and equipment you are using.



Injury or death may occur by attempting to use a damaged Valve. Per NFPA 1962, the device shall be inspected and tested at least quarterly. Before use inspect for damage resulting from:

- Failure to drain valve followed by exposure to freezing conditions
- Exposure to temperatures in excess of 160 degrees F
- Missing parts, physical abuse



This equipment is intended for use by trained personnel for firefighting. Its use for other purposes may involve hazards not addressed by this manual. Seek appropriate guidance and training to reduce risk of injury.



Kinks in supply hose may reduce water flow and cause injury or death to persons dependant on water flow. Avoid tight bends to minimize risk of hoseline kinks.



The appliance may be damaged if frozen while containing significant amounts of water. Such damage may be difficult to detect visually and can lead to possible injury or death. Any time the appliance is subject to possible damage due to freezing, it must be hydrostatically tested by qualified personnel before being considered safe for use.



The RC valve may be remotely operated. The electric drives are current limited but may still produce enough force to cause injury. Keep hands and fingers away from pinch points on the valve.



Do not use the manual override hand wheel while the electric controls are in operation. The electric drives produce enough torque to cause injury.



The Ball Intake Valve RC and the Jumbo Ball Intake Valve RC have current limiting capabilities which stops the motor if an obstruction is encountered. The RC valve must be installed as instructed using the correct controls and electrical boxes. Failure to do so will result in damage to the electric motor and loss of current limiting controls. This may result in injury.



Maximum operating pressure for the valve is 250 PSI (17 bar). Do not exceed 250 PSI on either side of the valve.



Valve must be properly connected. Mismatched or damaged connectors may cause leaking or uncoupling under pressure and could cause injury.



Any alterations to the valve and its markings could diminish safety and constitutes a misuse of this equipment.



Use with salt water is permissible provided the valve is thoroughly cleaned with fresh water after each use. The service life of the valve may be shortened due to the effects of corrosion and is not covered under warranty.

3.0 GENERAL INFORMATION

The Low Profile Jumbo Ball Intake Valve is intended for use on either the intake manifold of a fire engine or on a discharge port of a fire main. The valve is available in versions to minimize interference with surrounding components. The valve is kept closed while the water supply from a hydrant or another pumper to the engine is being established. This prevents the pump from sucking air through the intake manifold and losing its prime. Once the supply hose is filled and under pressure, and the air has been vented from the hose, the valve may be opened to connect the pump to the water supply. An adjustable pressure relief valve mounted on the valve opens to relieve any excess pressure that may damage the hose or the pump. The valve may be used for pressure or vacuum/drafting service.

An electric remote controlled (RC) model allows the valve to be operated from a remote location. A typical installation will consist of the RC valve and a remote display operator station. Motor controls are designed to auto sense 12 VDC or 24 VDC operation. The motor control circuit utilizes a position encoder and current limiting to protect the drive train at the ends of travel. Unit is supplied with 2' of cable with a plug on RC valve and 15' of cable with a receptacle so installation effort is minimized. Cable has only four conductors (two for power and two for communications) further easing installation effort. To complete the installation, the installer will need to mount and wire the remote display operator station. The display has 20' of cable. The power supply for the RC valve will need to be connected to a protected circuit from the trucks power distribution center. Refer to the specifications Section 3.1 for nominal current draw.

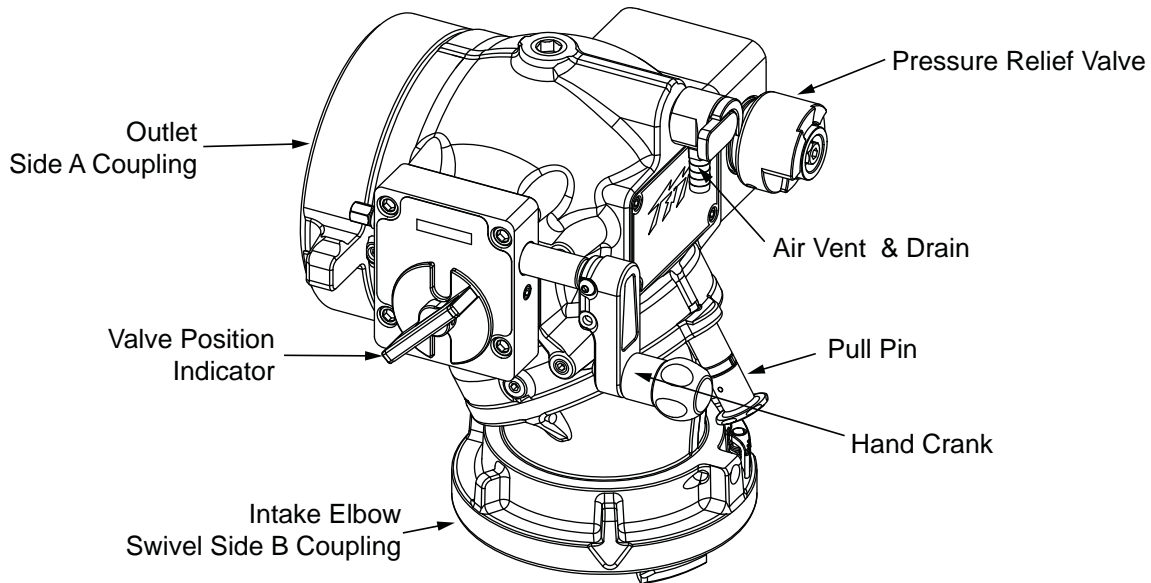

AXD1ST-NX-F
Jumbo Low Profile Ball Intake Valve
With Pressure Relief Valve

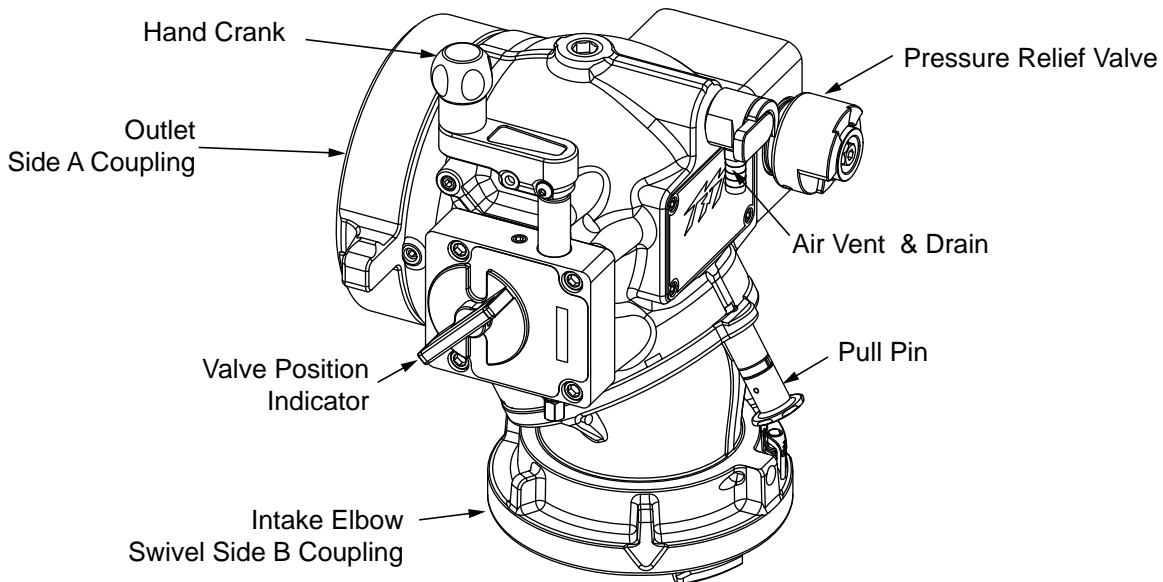

AXD1ST-NX-T
Jumbo Low Profile Ball Intake
With Pressure Relief Valve

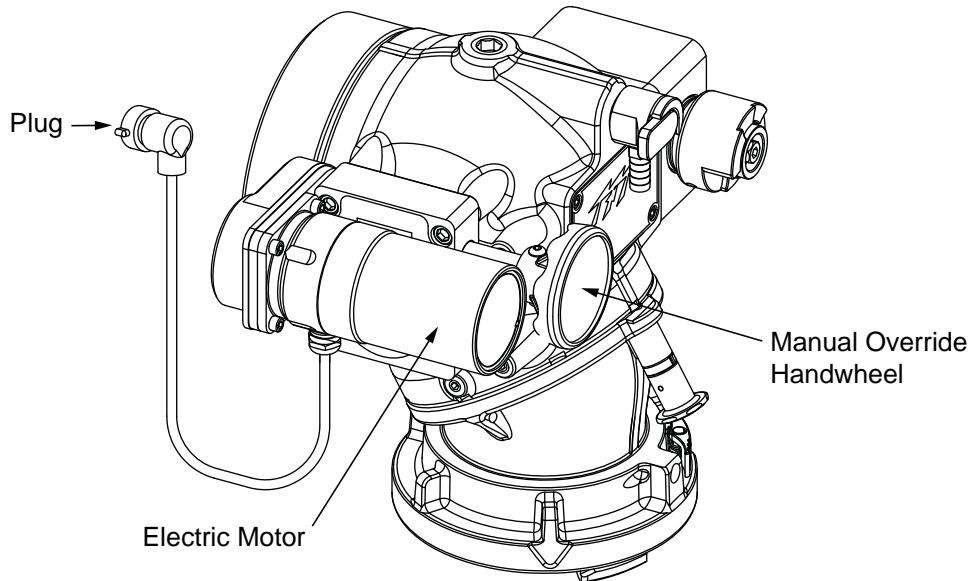

AXD1ST-NX-RC
Jumbo Low Profile Ball Intake Valve RC
With Pressure Relief Valve

Figure 3.0
General Information

3.1 SPECIFICATIONS

MODEL	LOW PROFILE JUMBO INTAKE VALVE	
Waterway Size	5.25" (133mm)	
Max Pressure	250 psi (17 bar)	
Min Pressure	Full Vacuum	
Temperature Rating*	-25°F to 135°F (-32°C to 57°C)	
Opening/Closing Speed	Meets NFPA 1965 Slow Close Requirements	
Environmental Rating	All components designed to meet minimum rating of NEMA 4 (IP65)	
Motor Opening/Closing Speed	6 sec	
Voltage - Auto Sense	12 Volt	24 Volt
Motor Current - Nominal	3 amp	1.5 amp
Motor Current - Limit	12 amp	6 amp
Recommended Fuse Size	15 amp	7.5 amp
*For temperatures below 32°F(0°C), valves must be drained after use to avoid damage. See section 2.0 SAFETY.		

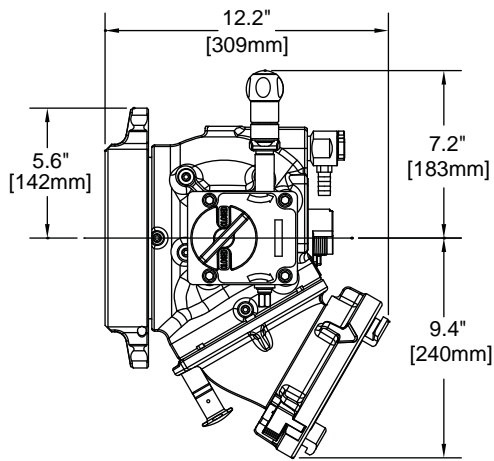
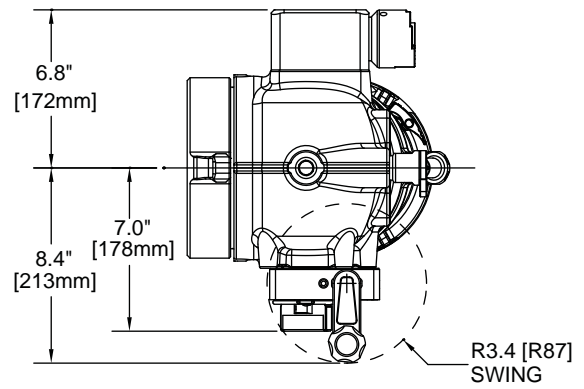
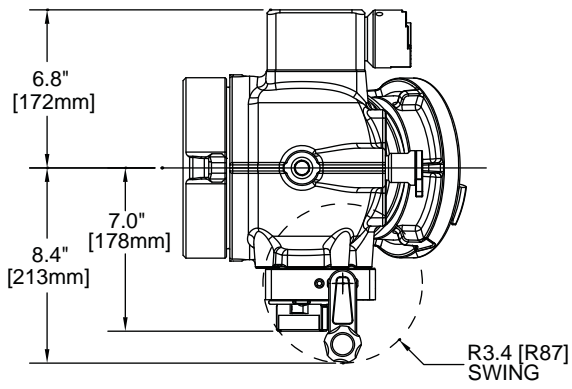

AXD1ST-NX-T
Angled Position

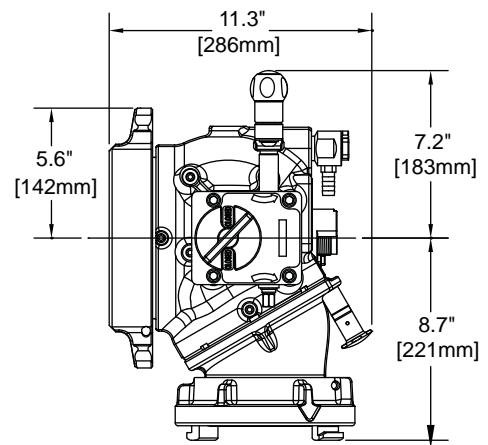

AXD1ST-NX-T
Down Position

Figure 3.1.1a
Overall Dimensions:
Jumbo Low Profile Ball Intake Valve Top Crank With Pressure Relief Valve

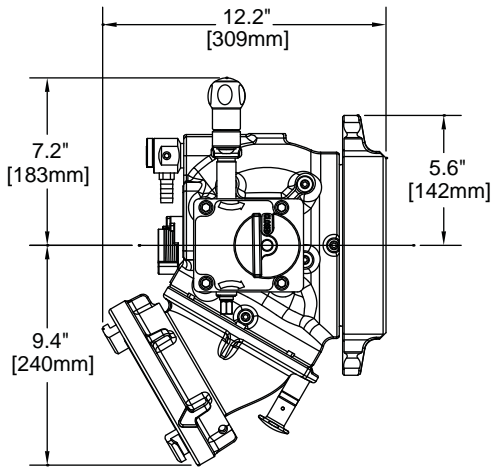
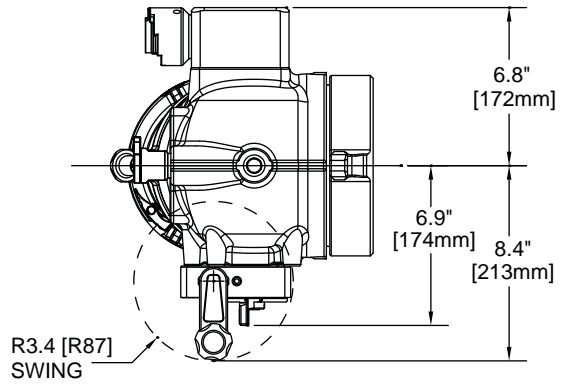
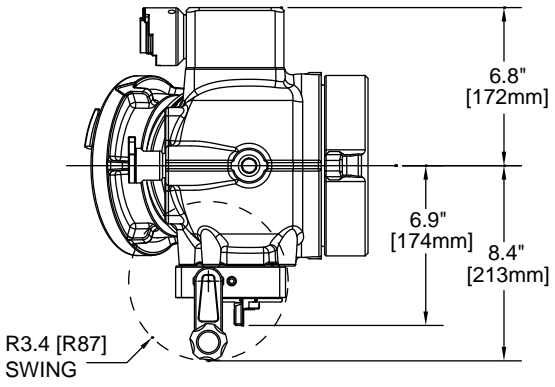

AXE1ST-NX-T
Angled Position

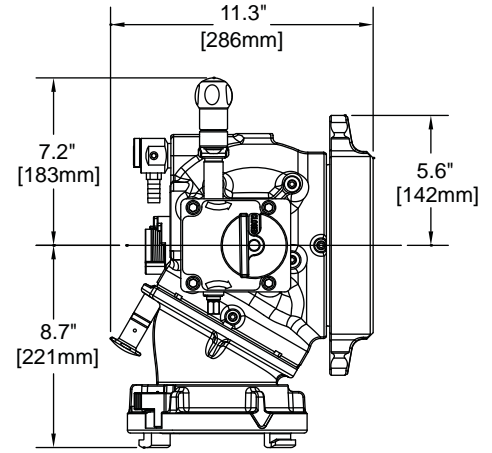

AXE1ST-NX-T
Down Position

Figure 3.1.1b
Overall Dimensions:
Jumbo Low Profile Ball Intake Valve Top Crank With Pressure Relief Valve

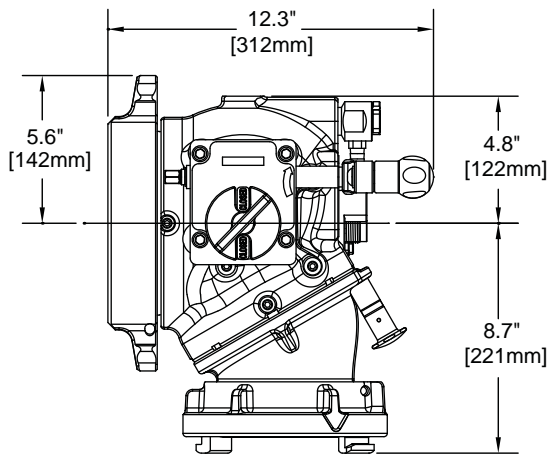

AXD1ST-NX-F
Down Position

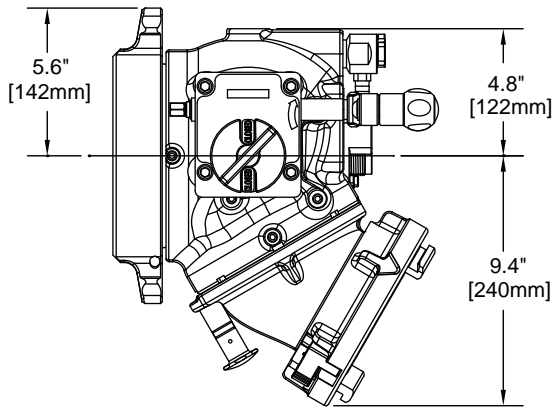
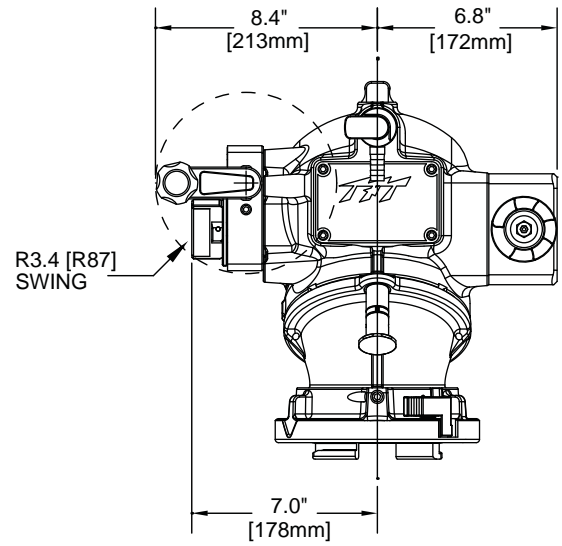

AXD1ST-NX-F
Angled Position

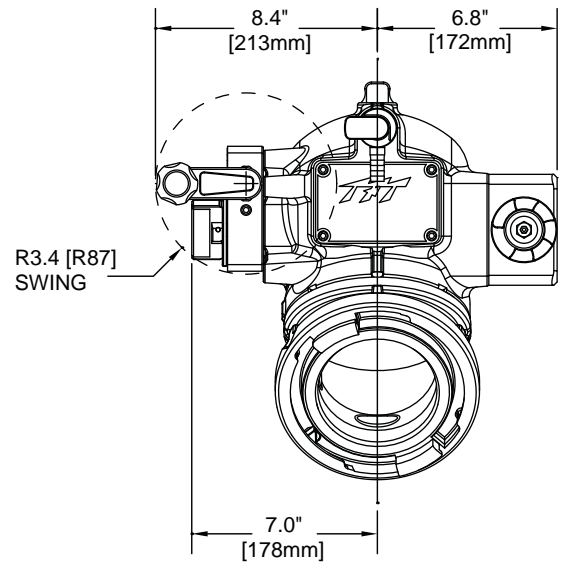
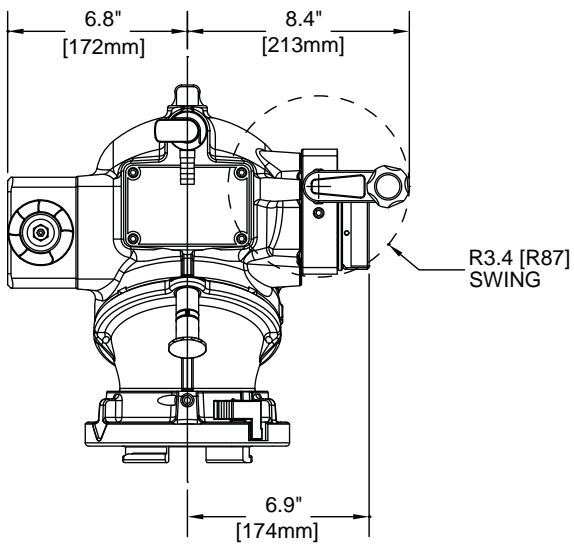
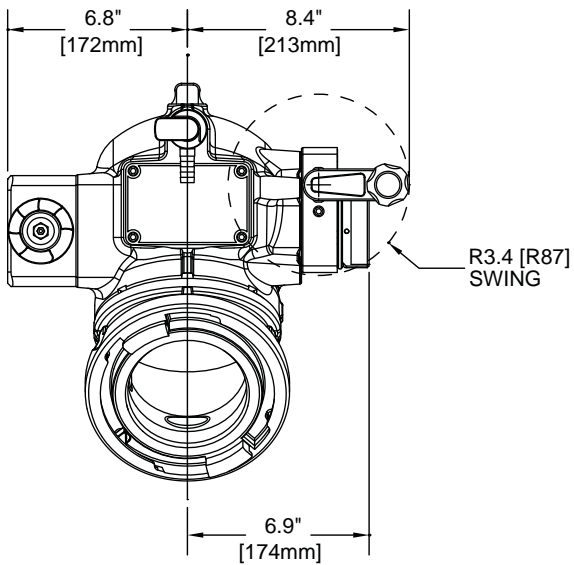
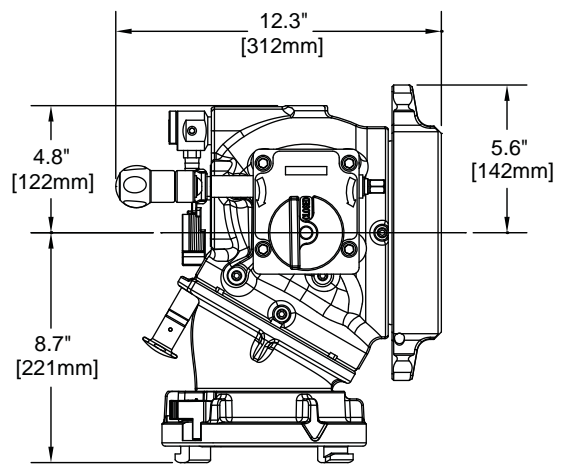

Figure 3.1.2a
Overall Dimensions:
Jumbo Low Profile Ball Intake Valve Front Crank With Pressure Relief Valve



AXE1ST-NX-F
Down Position



AXE1ST-NX-F
Angled Position

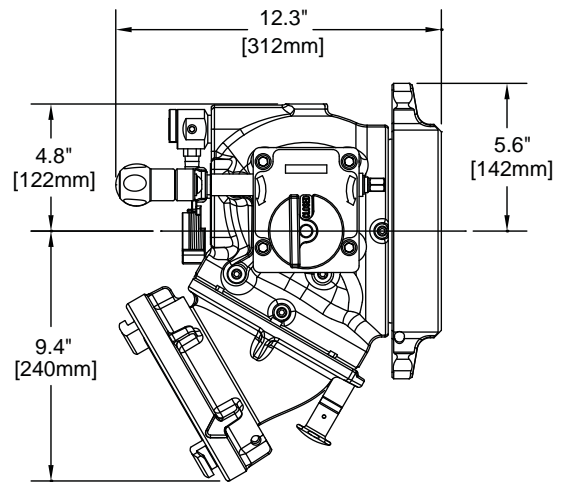
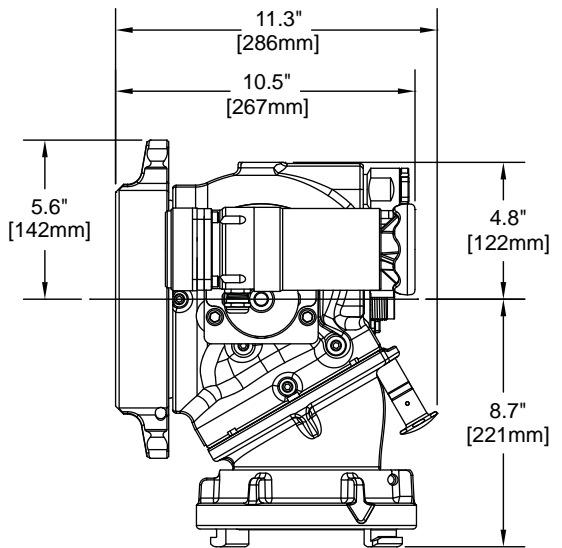
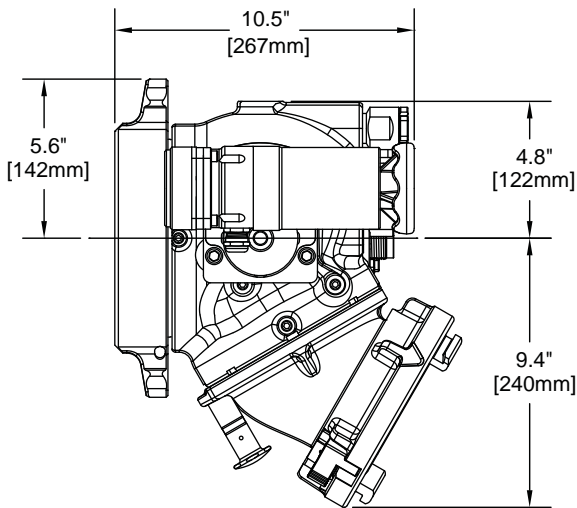
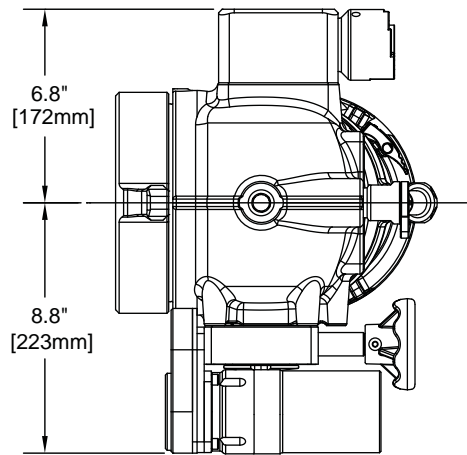
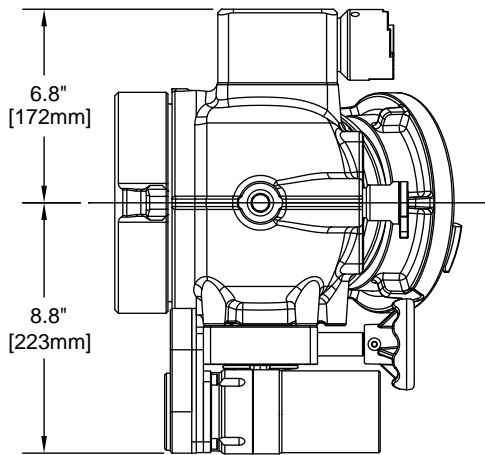

Figure 3.1.2b
Overall Dimensions:
Jumbo Low Profile Ball Intake Valve Front Crank With Pressure Relief Valve



AXD1ST-NX-RC
Angled Position

AXD1ST-NX-RC
Down Position

Figure 3.1.3a
Overall Dimensions:
Jumbo Low Profile Ball Intake Valve RC With Pressure Relief Valve

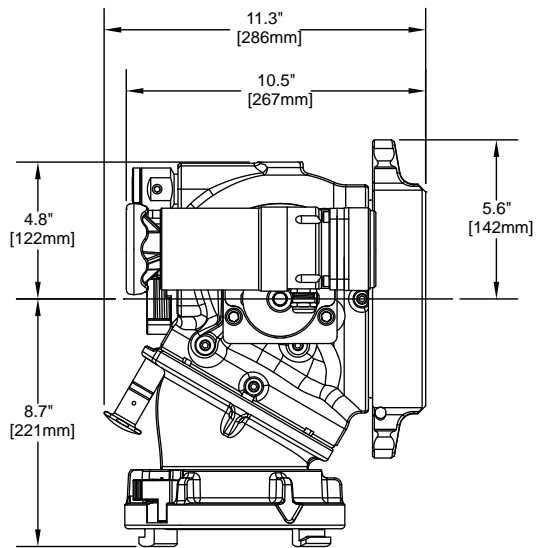
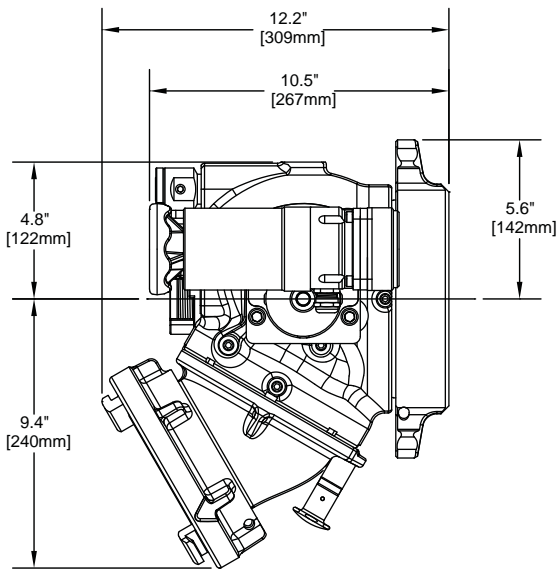
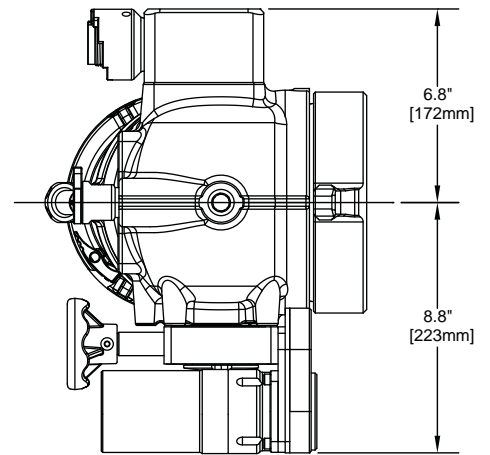
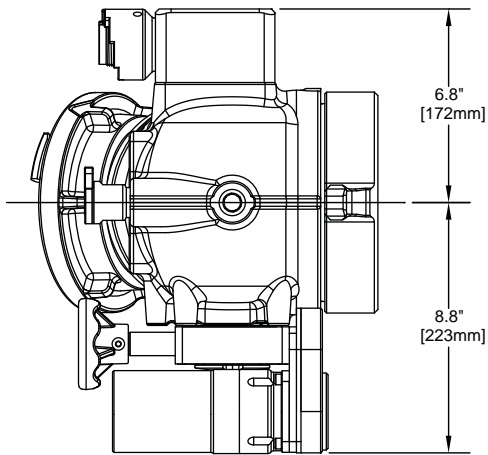

AXE1ST-NX-RC
Angled Position

AXE1ST-NX-RC
Down Position

Figure 3.1.3b
Overall Dimensions:
Jumbo Low Profile Ball Intake Valve RC With Pressure Relief Valve

3.2 CORROSION

Aluminum parts are hard anodized. All castings are then powder coated inside and out to help prevent corrosion. Hose couplings are attached using polymer bearing rings which provide electrical insulation to help prevent galvanic corrosion. The effects of corrosion can be minimized by good maintenance practice. See section 9.0 MAINTENANCE.

3.3 USE WITH SALT WATER

Use with salt water is permissible provided valve is thoroughly cleaned with fresh water after each use. The service life of the valve may be shortened due to the effects of corrosion and is not covered under warranty.

4.0 INSTALLATION

4.1 MOUNTING THE VALVE

Screw the large coupling to a pump manifold or fire water discharge port and tighten securely. The valve position indicator should be clearly visible, but need not be level.

CAUTION Dissimilar metals coupled together can cause galvanic corrosion that can result in the inability to unscrew the threads and complete loss of thread engagement over time. Per NFPA 1962 (2013 edition), if dissimilar metals are left coupled together an anti-corrosive lubricant should be applied to the threads. Also, the coupling should be disconnected and inspected at least quarterly.

4.2 ENCLOSURE MOUNTING

Select proper location for display. A full size template is shown in 12.0 TEMPLATES.

4.3 ELECTRIC INSTALLATION AND WIRING

Red (+) and black (-) wires must be connected to a 12 or 24 VDC protected circuit from the truck's power distribution center. Figure 4.3 shows the control connections.

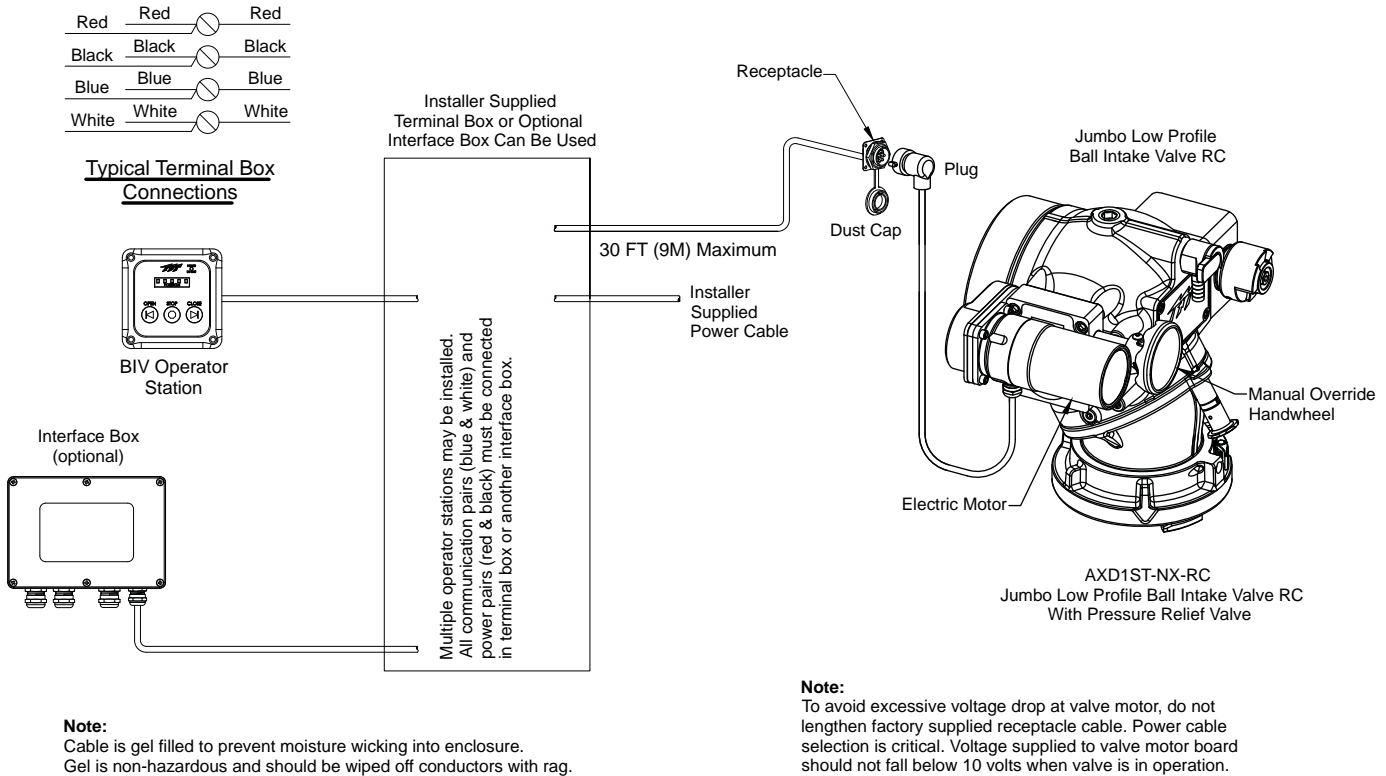

Figure 4.3

WARNING The electric motor and other components are ignition sources. The electric BIV should be operated only in areas where there is adequate ventilation and no hazard of flammable vapor buildup.

4.4 ELECTRICAL TESTING

VERIFY PROPER VOLTAGE

The TFT Ball Intake Valve RC has built in circuit protection to guard against a circumstance where the unit's movement is blocked before reaching its full travel limits. Without this circuitry the motor would stall, overheat, and could be permanently damaged.

IMPORTANT - When mechanical installation and electrical connections are complete, perform the following test to verify voltage supply is adequate and the current limiting feature is functioning.

1. Apply power to Valve Control.
2. Press OPEN or CLOSE button and hold until valve reaches stop position. Continue to hold button down.
3. Once movement is stopped, manually turn override knob in opposite direction while continuing to hold button down. If knob can be turned, then voltage supply is adequate. If knob can't be turned and motor continues to operate, then the current limit was not reached because the voltage supply or wiring is not adequate.

NOTE: Override knob will only turn in one direction.

To ensure proper voltage to the Ball Intake Valve RC, the wiring needs to be checked for proper gauge for the installed length of wire, and for proper termination. Also, ensure that the power source supplying the BIV RC and the grounding are adequate (other electrical loads on a shared circuit with the BIV RC may cause a low-voltage situation).

In addition to motor damage, a further consequence of low voltage could be that the valve will not open or close properly or fully.

SET TRAVEL STOPS

When proper voltage is verified, perform the following to set the full travel limits.

1. Apply power to Valve Control.
2. Press CLOSE button and continue to hold until valve is fully closed. Motor must stop by current limit method. If motor continues to operate see proper voltage section above.
3. Press OPEN button and continue to hold until valve is fully open. Motor must stop by current limit method. If motor continues to operate see proper voltage section above.
4. Position indicator lights will now track valve movement.

4.5 BALL INTAKE VALVE RC MANUAL OVERRIDE

The Ball Intake Valve RC is motor driven but also has an override handwheel for operating the valve manually. The override handwheel may also be used in the event of power failure. If electrical power is supplied to the control panel then the LED valve position display will track the valve's position as the handwheel is moved. If the handwheel is moved while there is no power to the electric controls than the LED valve position display will be in error when the electric power is reconnected. The LED valve position indicator will self correct the first time the valve is cycled under electric control.

If more compactness is desired the override handwheel may be removed. The drive shaft has a hex so a wrench or socket may be used for manual override. If the manual override handwheel is removed assure that the correct size wrench or socket is available in the event of power failure.

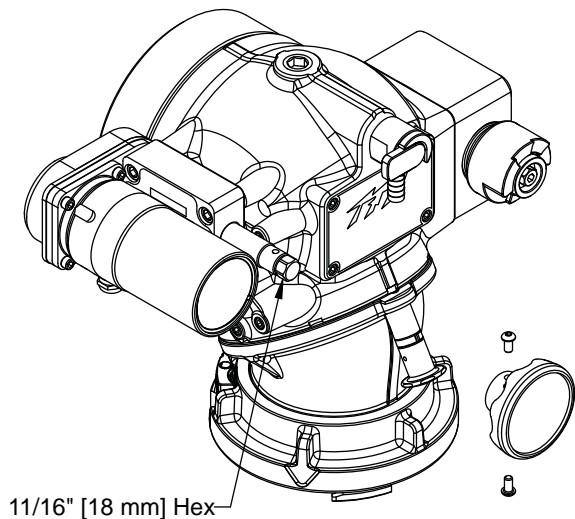

Figure 4.5
RC Valve Manual Override

4.6 CHANGING OFFSET OF CRANK HANDLE

When equipped with a crank handle, two offset positions are available to adjust the swing radius of the crank and knob as shown in figure 4.6. The longer offset position offers reduced effort to operate the valve. The shorter offset is available to avoid interference with other equipment on the apparatus. To change the offset, remove two 1/4"-20 x 1/2" button head cap screws from crank. Place crank in desired position and replace screws. Apply Blue Loc-Tite thread locking compound to all of the screw threads.

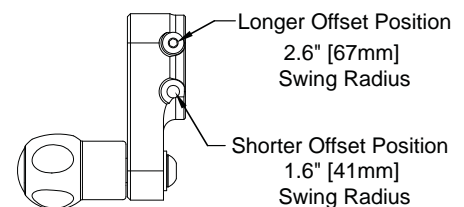

Figure 4.6
Crank Handle Offset

4.7 CHANGING COUPLING LOCK-OUT

To change a coupling from rigid to full time swivel, use a 7/32" Allen driver to back out the lockout screw until the coupling moves freely.

To change a coupling from full time swivel to rigid, first align the pull pin in the elbow to vertical. Rotate the coupling until the lockout screw is aligned with the pull pin. Use a 7/32" Allen driver to tighten the lockout screw into the lockout divot in the elbow. Do not tighten the screw onto the polymer bearing strip.

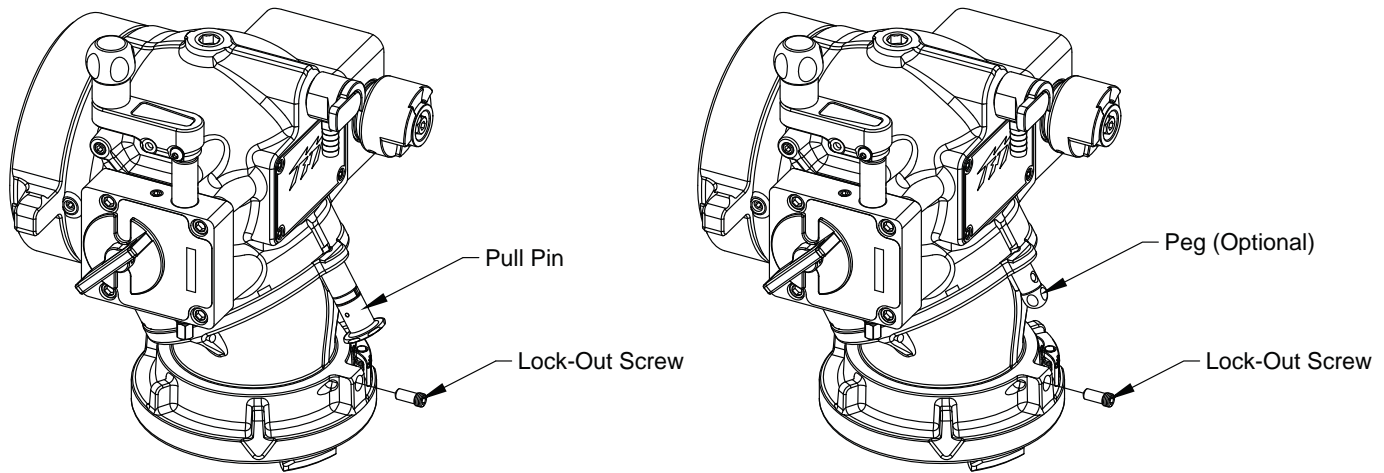

Figure 4.7.
Coupling Lock-Out

4.8 PEG

If total overall depth is critical or if the pull pin remains hidden behind the valve and is hard to find the Pull Pin can be replaced with an optional Peg (TFT #A1576) to reduce overall depth from 11.3" to 10.4" on top crank versions. The peg does not lock into detents.

4.9 STORZ 'SUCTION GASKET' REQUEST

If your application of this product requires drafting, you may need a suction gasket, please call 1-800-348-2686 to receive a free suction gasket by mail.

Part Numbers: 4" STORZ - item # A4216, 5" STORZ - item # A4221, 6" STORZ - item #A4273

5.0 USE

5.1 ELBOW

The elbow swivels 360 degrees to help prevent hose kinks, and make connection of suction lines easier. The elbow can be turned forward or backward to help make connections in tight places if the water supply is in front of or behind the truck. There is a hole on the side of the elbow that can be used to attach the lanyard or chain of a cap by use of a key ring.

5.2 VALVE OPERATION

The valves covered by this manual utilize positive stops at the OPEN and CLOSED positions. Attempting to close a valve further than the positive stops will not result in a tighter seal between the ball and valve seat. All valves include markings to indicate the direction of handle rotation to open the valve.

Valves with hand cranks include a valve position indicator. To open the valve, turn the hand crank until the valve position indicator shows OPEN. To close the valve, turn the hand crank the opposite way until the valve position indicator shows CLOSED.

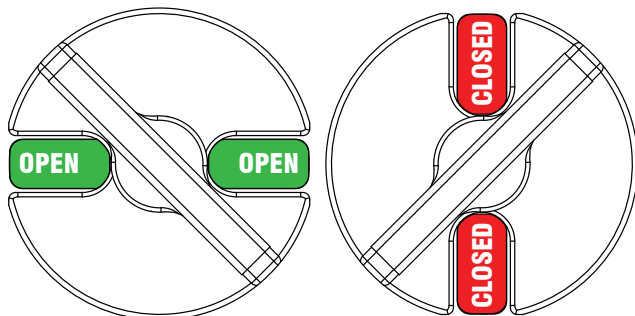

Figure 5.2A
AXD* Finished Goods Valve Position Indicator

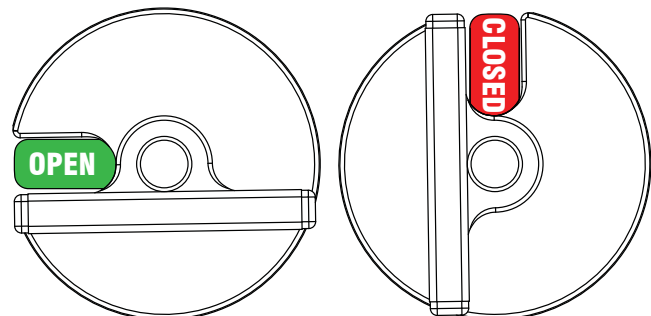

Figure 5.2B
AXE* Finished Goods Valve Position Indicator

Up to the maximum rated pressure, operating torque should never exceed the values in the table below. If greater torque is required to operate the valve, then that is an indication that the valve needs maintenance. Exceeding 30 ft-lb / 41 N-m torque may damage the appliance. Kicking or standing on the valve controls is considered misuse of the appliance.

Valve Seat Bore Size		Max Acceptable Torque		Max. Acceptable Force on Knob	
5.25 in	133 mm	30 ft-lb	41 N-m	137 lb	62 kg

Exceeding 45 ft-lb will cause one side of the crank shaft to shear off. This is intentional to prevent further damage to the gearbox. If the shaft shears off, the valve can be operated temporarily using a wrench on the ½” hex on the opposite side of the crankshaft. For repair instructions, see section 9.2 CRANKSHAFT OVERRIDE AND REPLACEMENT.

5.3 BALL INTAKE VALVE RC OPERATION

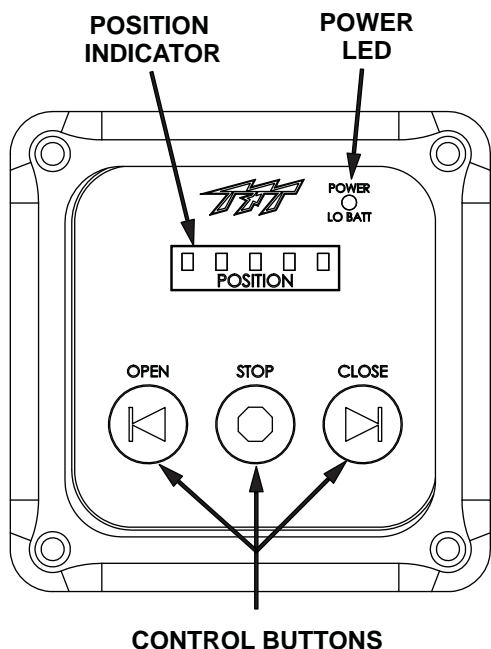

Figure 5.3
RC Operation

Power LED:

LED will be solid green when power is present

Position Indicator:

5 LEDs indicate valve position. One for full close (red at far right), one for full open (green at far left), three yellow for 25%, 50%, and 75% open. Two LEDs will light when position is between two percentages.

Note: The position indicator will lose position if the manual override is used while the power is off. Position location is restored after the first cycle of electric operation.

All 5 position LED's blinking indicates a fault with the motors encoder.

Control Buttons:

Manual Mode

When OPEN or CLOSE button is pressed, valve opens or closes until button is released.

Automatic Mode

When OPEN or CLOSE button is momentarily pressed, valve opens or closes fully.

During valve movement if STOP or the other direction is momentarily pressed the motor will stop.

Changing Modes (Unit is shipped from factory in the Auto Mode)

Press CLOSE and STOP buttons together and hold for 3 seconds to change to Automatic Mode.

Press OPEN and STOP buttons together and hold for 3 seconds to change to manual mode.

5.4 AIR VENT AND WATER DRAIN



Loss of prime can interrupt water flow and cause injury or death. Always bleed out air with air valve to prevent possible loss of prime.

The BIV-LP comes with an Air Vent/Drain Valve situated on the front of the valve. There is a second plugged port on the top of the valve. To use a different port position, relocate the factory supplied Air Vent/Drain Valve or install an additional Air Vent/Drain Valve. If the Air Vent/Drain Valve is being relocated, use a ¾” NPT plug to seal the empty port.

5.5 PRESSURE RELIEF VALVE



Do not leave the pressure relief valve in the OFF position. The pressure relief valve is disabled in the OFF position and offers no protection against over pressurization. The OFF position may be used for controlled pump testing but should not be used for service conditions. Exercise great care to avoid water hammer or other pressure spikes when the pressure relief valve is in the OFF position.



The Pressure Relief Valve may be damaged if frozen while containing significant amounts of water. Such damage may be difficult to detect visually and can lead to possible injury or death. Any time the Pressure Relief Valve is subject to possible damage due to freezing, it must be hydrostatically tested by qualified personnel before being considered safe for use.

LDH valved appliances may be equipped with a pressure relief valve that can be set to any pressure between 90 and 300 psi. Its function is to protect the pump and supply hose from excess pressure. An optional threaded outlet (TFT #A1114) is available for connecting a hose to discharge opening to direct water away from valve. Consult factory for thread options.

See [LIA-202](#) Pressure Relief Valve Instructions for Safe Operation and Maintenance.

5.5.1 RELIEF VALVE SETTING PRESSURE

To set the relief valve pressure turn the adjusting screw on the relief valve housing until the surface of the screw is even with the desired pressure. A 9/16" (14mm) socket or a 1/4" (6mm) Allen wrench may be used to turn the adjusting screw. The Pressure relief valve should not be disabled (IE: capped, plugged, or set to the OFF position) for normal service conditions. Disabling the relief valve may result in system damage or hose rupture if the system exceeds operating limits. The pressure relief valve meets the requirements of NFPA 1901.

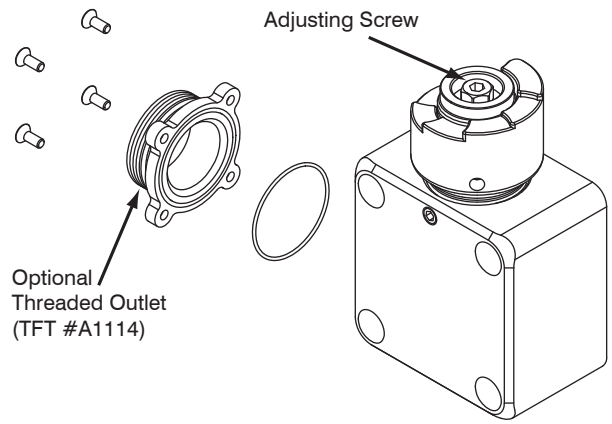

Figure 7.1
Pressure Relief Valve

5.6 PRESSURE LOSS

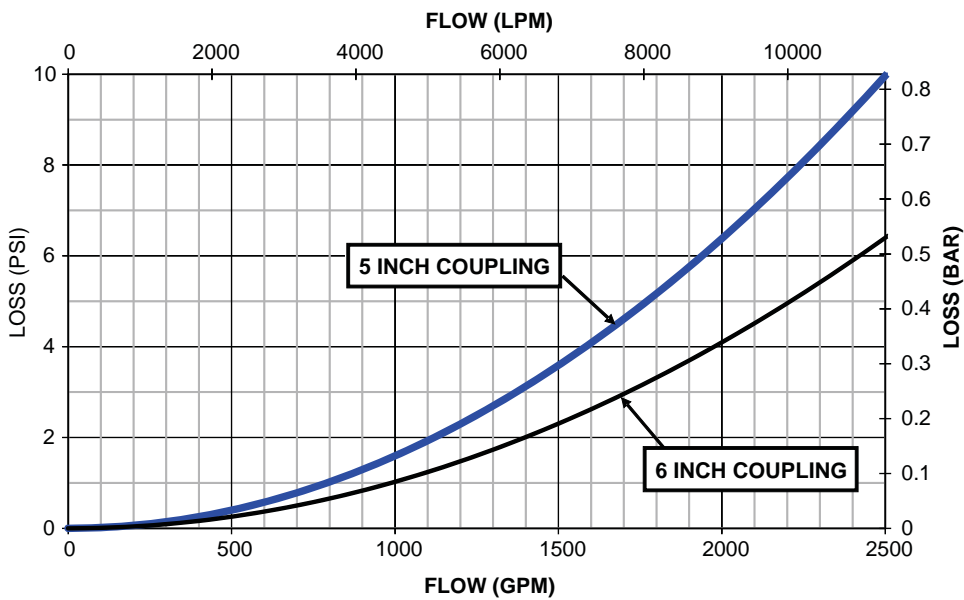

Figure 5.6
Pressure Loss Chart

5.7 SUCTION SCREEN

This device may be equipped with a suction screen to catch debris larger than 3/8" diameter in the waterway. See chart to determine additional loss caused by the screen. To add or replace a suction screen, order TFT part #A1410-KIT for the 4.5" waterway, and TFT part #A1411-KIT for the 5.0" waterway.

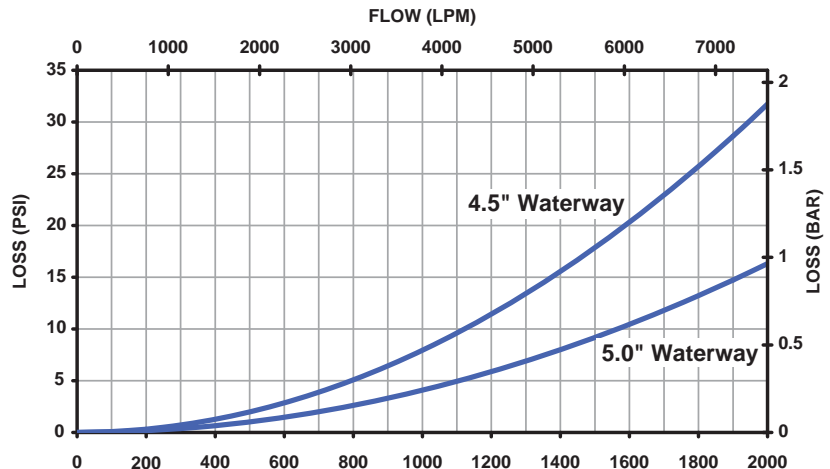
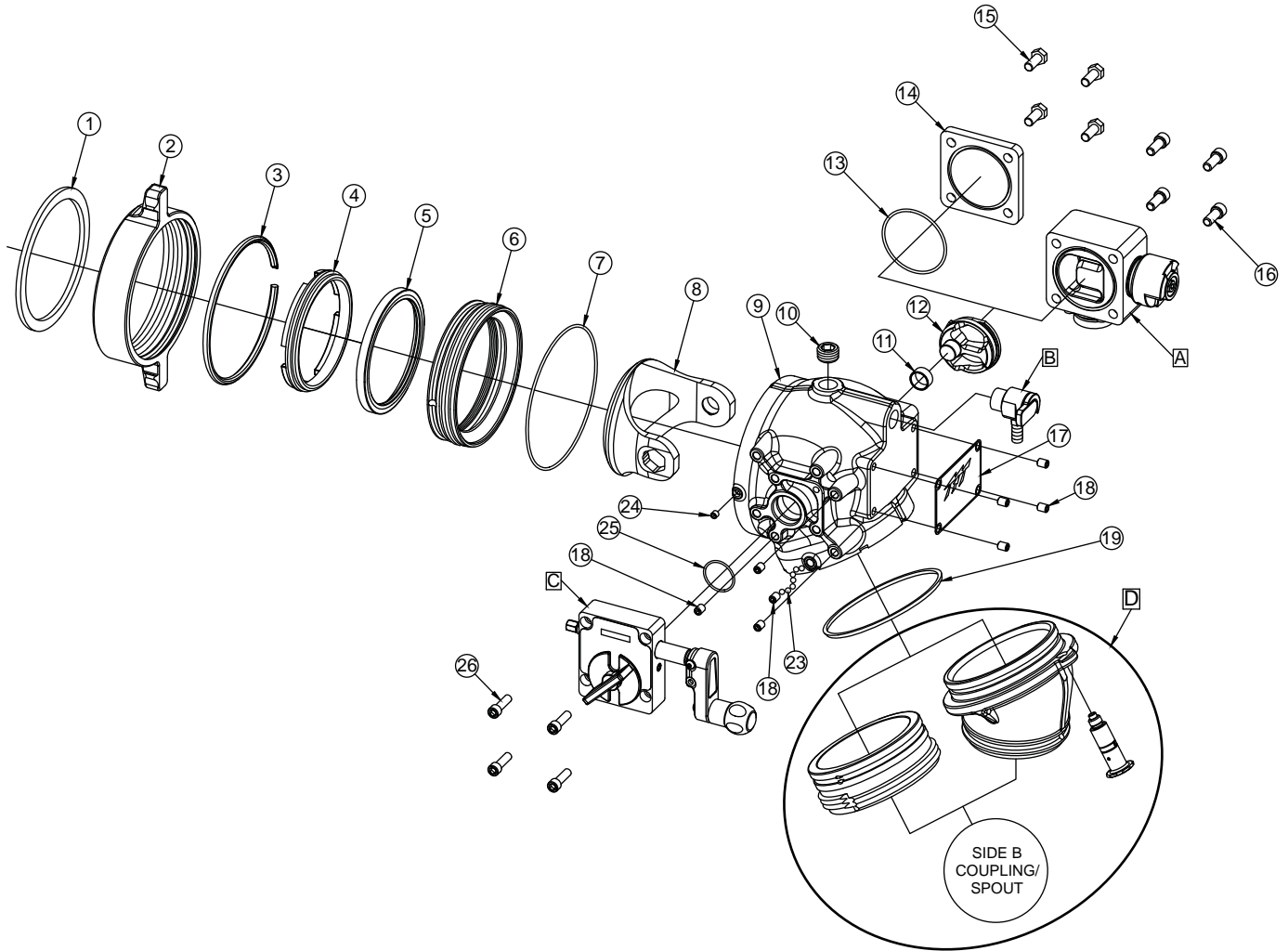

Figure 5.7
Suction Screen Pressure Loss

6.0 EXPLODED VIEWS AND PARTS LISTS

6.1 JUMBO BALL INTAKE VALVE - AXD SERIES EXPLODED VIEW AND PARTS LIST



INDEX	DESCRIPTION	QTY	PART #
1	GASKET - 6.0"	1	V3240
2	COUPLING SH 6.0"NHF X PSF7.0-NFS	1	A1266NX
	COUPLING SH 5.0"NHF X PSF7.0 NFS		A1261NT
3	PLASTIC STRIP 7.00"	1	A1290
4	SEAT RETAINER 6" ALUMINUM	1	ZB1025A
	6" SEAL RETAINER ALUM FOR 5.0" COUPLINGS		A1081A
5	VALVE SEAT	1	A1082
6	6" BACK RING ALUMINUM	1	A1084A
7	O-RING-262	1	VO-262
8	HALF BALL 8" ALUM NO_DRAIN	1	A1088A
9	RIGHT BODY	1	A1085
	LEFT BODY		A1085L
10	3/4"NPTM HEX SOCKET PLUG	1	XG410
11	BUSHING HALF BALL TRUNNION	1	A2094
12	TRUNNION ALUMINUM	1	A1087A
13	O-RING-236	1	VO-236

INDEX	DESCRIPTION	QTY	PART #
14	LDH BLANK CAP	1	X631
15	7/16-14 X 1 HEX HEAD BOLT	4	VT43-14HX1.0
16	7/16-14 X 1 SOCKET HEAD SCREW	4	VT43-14SH1.0
17	TFT NAME LABEL	1	A1313
18	3/8-16 X 1/2 SOCKET SET SCREW	7	VT37-16SS500
19	CUP SEAL	1	A1545
21	PULL PIN SUBASSEMBLY	1	A1615
23	1/4 SS BALL	72	V2125
24	5/16-18 X 3/8 SOCKET SET SCREW	2	VT31-18SS375
25	O-RING-128	1	VO-128
26	3/8-16 X 1-1/4 SOCKET HEAD SCREW	4	VT37-16SH1.2
A	AXD (LEFT DRIVE) PRESSURE RELIEF VALVE	1	A1641L
	AXE (RIGHT DRIVE) PRESSURE RELIEF VALVE		A1641R
B	AIR VENT/DRAIN VALVE	-	SEE SECTION 6.5
C	WORM DRIVE GEARBOX	-	SEE SECTION 6.4
D	SIDE B COUPLING/SPOUT	1	SEE SECTION 6.3

6.2 MOTOR ASSEMBLY JUMBO LOW PROFILE BIV RC PARTS LIST

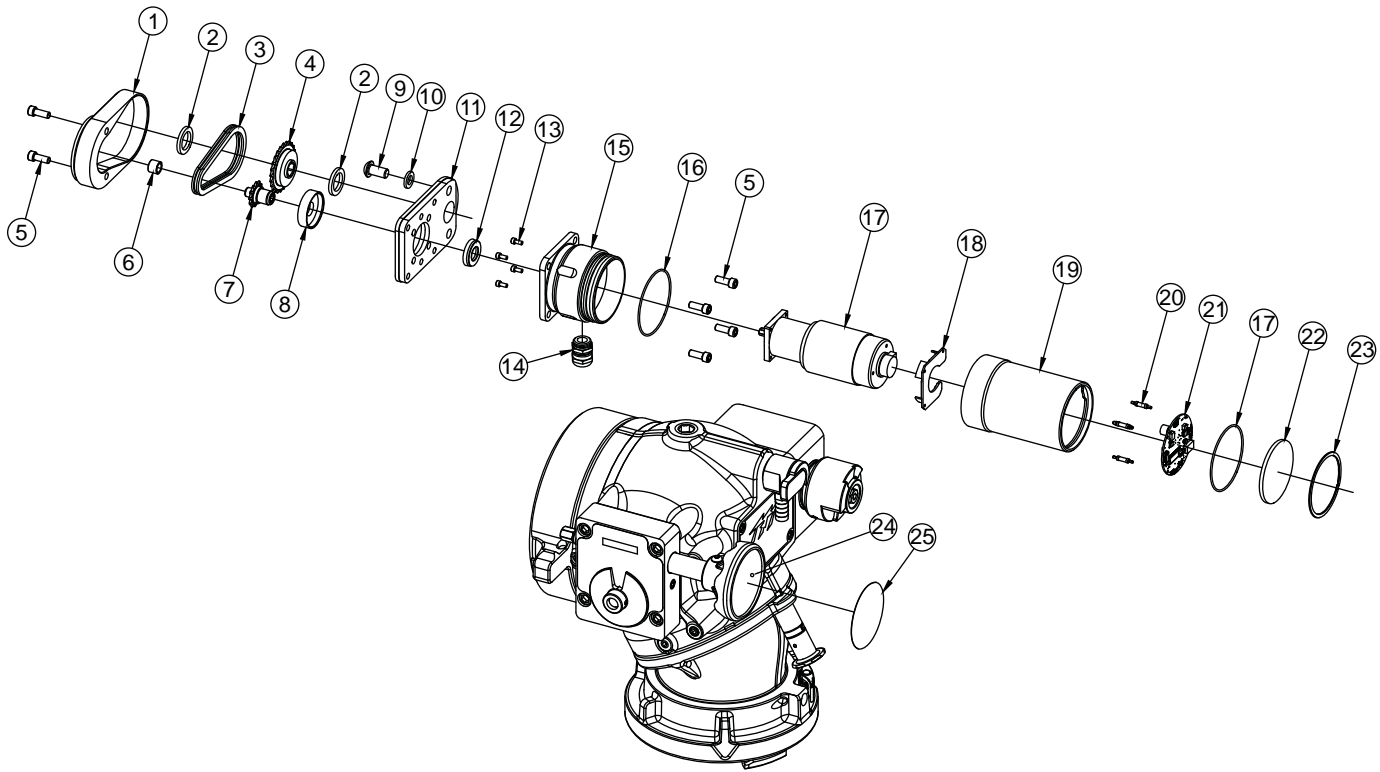

INDEX	DESCRIPTION	QTY	PART #
1	REDUCER COVER	1	A1097
2	THIN WASHER	2	A1530
3	38 LINK ROLLER CHAIN	1	AX1685
4	BIV SPROCKET 25	1	A1098
5	1/4-28 X 5/8 SOCKET HEAD SCREW	6	VT25-28SH625
6	BUSHING NYLON	1	X252
7	DRIVE SPROCKET	1	X253
8	BUSHING MOTOR	1	X256
9	3/8-16 X 3/4 BUTTON HEAD SCREW	1	VT37-16BH750
10	LOCK WASHER 3/8"	1	VW375SSLOCK
11	REDUCER HOUSING	1	A1096
12	CUP SEAL	1	Y4620

INDEX	DESCRIPTION	QTY	PART #
13	6-32 X 5/16 SHCS WITH SILICONE HEAD SEAL	4	VT06S32SH312
14	STRAIN RELIEF	1	Y5205
15	MOTOR SOCKET	1	Y4615
16	O-RING-038	2	VO-038
17	GEAR MOTOR W/CRIMPED TERMINALS	1	Y4600
18	MOTOR BOARD SUPPORT	1	Y4643
19	MOTOR ENCLOSURE TUBE	1	Y4641
20	CIRCUIT BOARD STANDOFF	1	Y5538
21	VALVE MOTOR BOARD	1	A5825
22	MOTOR ENCLOSURE CAP	1	Y4642
23	SMALLEY RING	1	V4295
24	KNOB	1	Z245
25	OVERRIDE KNOB LABEL	1	Y4176

6.3 SIDE B OPTIONS EXPLODED VIEWS AND PARTS LISTS

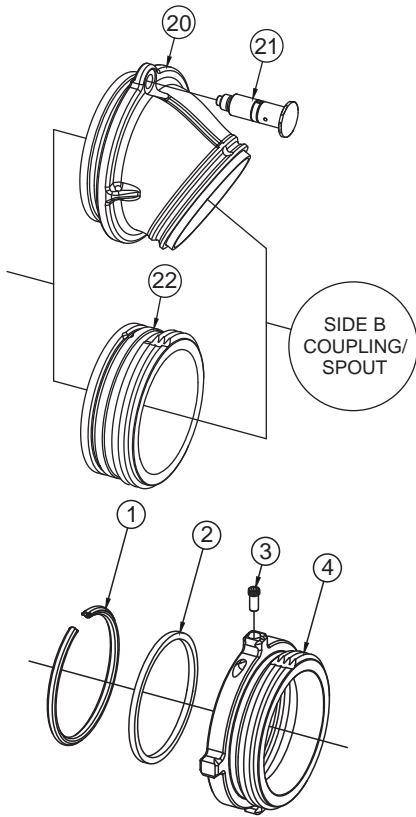

ELBOW - MALE HOSE THREADS						
INDEX	DESCRIPTION	QTY	4.0"	4.5"	5.0"	6.0"
20	ELBOW	1	A1054	A1054	A1054	A1091
21	PULL PIN SUBASSEMBLY	1	A1615	A1615	A1615	A1615
1	PLASTIC STRIP	1	A1291	A1291	A1291	A1293
2	CUP SEAL	1	A1596	A1596	A1596	A1594
3	LOCK-OUT SCREW	1	A1294	A1294	A1294	A1294
4	SPOUT	1	A4620N	A4625N	A4630N	A4640N

SHORT - MALE HOSE THREADS						
INDEX	DESCRIPTION	QTY	4.0"	4.5"	5.0"	6.0"
22	MATE/SPOUT	1	A1055	A1055	A4631N	A4641N
1	PLASTIC STRIP	1	A1291	A1291	—	—
2	CUP SEAL	1	A1596	A1596	—	—
3	LOCK-OUT SCREW	1	A1294	A1294	—	—
4	SPOUT	1	A4620N	A4625N	—	—

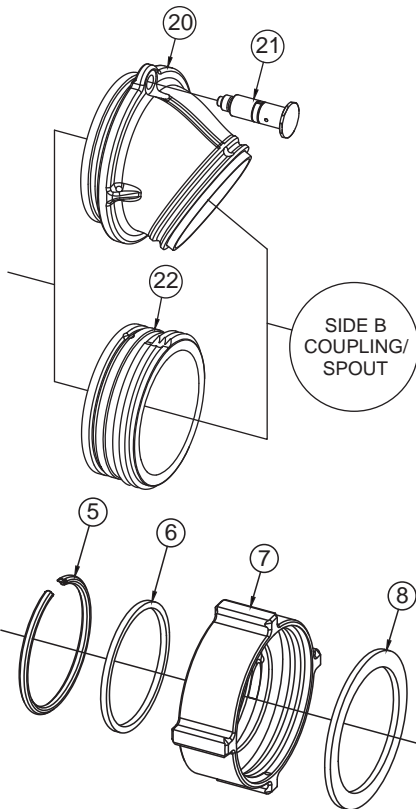

ELBOW - FEMALE HOSE THREADS ROCKER LUG						
INDEX	DESCRIPTION	QTY	3.5"	4.0"	4.5"	5.0"
20	ELBOW	1	A1054	A1054	A1054	A1054
21	PULL PIN SUBASSEMBLY	1	A1615	A1615	A1615	A1615
5	PLASTIC STRIP	1	A1291	A1291	A1291	A1291
6	CUP SEAL/O-RING	1	A1596	—	—	A1596
7	COUPLING	1	A4655N	A4662N	A4667N	A4670N
8	GASKET	1	V3196	V3198	V3210	V3220
-	NFS RING/O-RING	1	—	A4561/VO-248	A4566/VO-248	—
-	MATE	1	A4730	—	—	—
-	PLASTIC STRIP	1	A1292	—	—	—
-	CUP SEAL	1	A1597	—	—	—
-	BALL	1	VB.437	—	—	—

SHORT - FEMALE HOSE THREADS ROCKER LUG						
INDEX	DESCRIPTION	QTY	3.5"	4.0"	4.5"	5.0"
22	MATE/SPOUT	1	A1055	A1055	A1055	A1055
5	PLASTIC STRIP	1	A1292	A1291	A1291	A1291
6	CUP SEAL	1	A1597	-	-	A1596
7	COUPLING	1	A4655N	A4662N	A4667N	A4670N
8	GASKET	1	V3196	V3198	V3210	V3220
-	NFS RING/O-RING	1	—	A4561/VO-248	A4566/VO-248	—
-	MATE	1	A4730	—	—	—
-	PLASTIC STRIP	1	A1291	—	—	—
-	CUP SEAL	1	A1596	—	—	—
-	BALL	1	VB.437	—	—	—
-	BALL	1	VB.437	—	—	—

6.3 SIDE B OPTIONS EXPLODED VIEWS AND PARTS LISTS

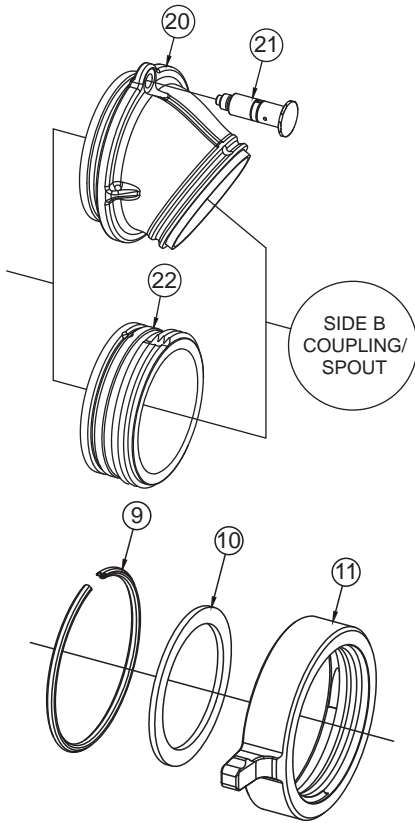

ELBOW - FEMALE HOSE THREADS LONG HANDLE						
INDEX	DESCRIPTION	QTY	4.0"	4.5"	5.0"	6.0"
20	ELBOW	1	A1054	A1054	A1054	A1091
21	PULL PIN SUBASSEMBLY	1	A1615	A1615	A1615	A1615
9	PLASTIC STRIP	1	A1291	A1291	A1290	A1293
10	GASKET	1	V3198	V3210	V3220	V3240
11	COUPLING	1	A4562N	A4567N	A4570NT	A4575NX
-	NFS RING/O-RING	1	A4561/VO-248	A4566/VO-248	—	A4576/VO-254
-	MATE	1	—	—	—	—
-	PLASTIC STRIP	1	—	—	—	—
-	CUP SEAL	1	—	—	—	—

SHORT - FEMALE HOSE THREADS LONG HANDLE					
INDEX	DESCRIPTION	QTY	4.0"	4.5"	5.0"
22	MATE/SPOUT	1	A1055	A1055	A1055
9	PLASTIC STRIP	1	A1291	A1291	A1290
10	GASKET	1	V3198	V3210	V3220
11	COUPLING	1	A4562N	A4567N	A4570NT
-	NFS RING/O-RING	1	A4561/VO-248	A4566/VO-248	—

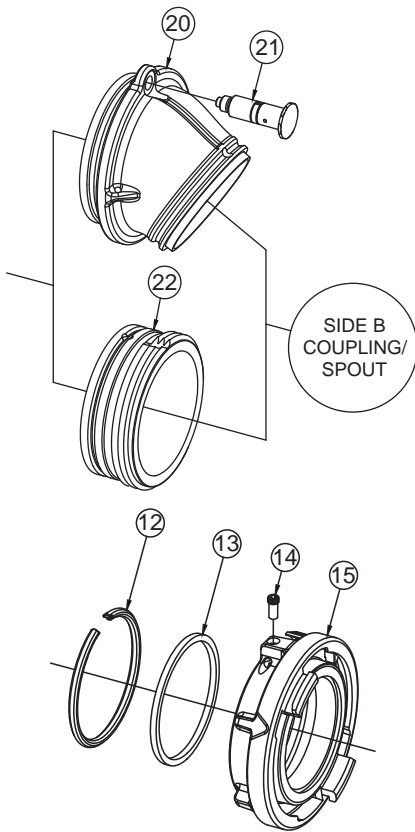

ELBOW - STORZ					
INDEX	DESCRIPTION	QTY	4.0"	5.0"	6.0"
20	ELBOW	1	A1054	A1054	A1091
21	PULL PIN SUBASSEMBLY	1	A1615	A1615	A1615
12	PLASTIC STRIP	1	A1292	A1291	A1293
13	CUP SEAL	1	A1597	A1596	A1594
14	LOCK-OUT SCREW	1	A1294	A1294	A1294
15	COUPLING	1	A4124	A4125	A4277
-	MATE	1	A4730	—	—
-	PLASTIC STRIP	1	A1291	—	—
-	CUP SEAL	1	A1596	—	—
-	BALL	1	VB.437	—	—

SHORT - STORZ					
INDEX	DESCRIPTION	QTY	4.0"	5.0"	6.0"
22	MATE/SPOUT	1	A1055	A1055	A1093
12	PLASTIC STRIP	1	A1292	A1291	A1293
13	CUP SEAL	1	A1597	A1596	A1594
14	LOCK-OUT SCREW	1	A1294	A1294	—
15	COUPLING	1	A4124	A4125	A4277
-	MATE	1	A4730	—	—
-	PLASTIC STRIP	1	A1291	—	—
-	CUP SEAL	1	A1596	—	—
-	BALL	1	VB.437	—	VB.437

6.4 WORM DRIVE GEARBOX [A] EXPLODED VIEW AND PARTS LIST

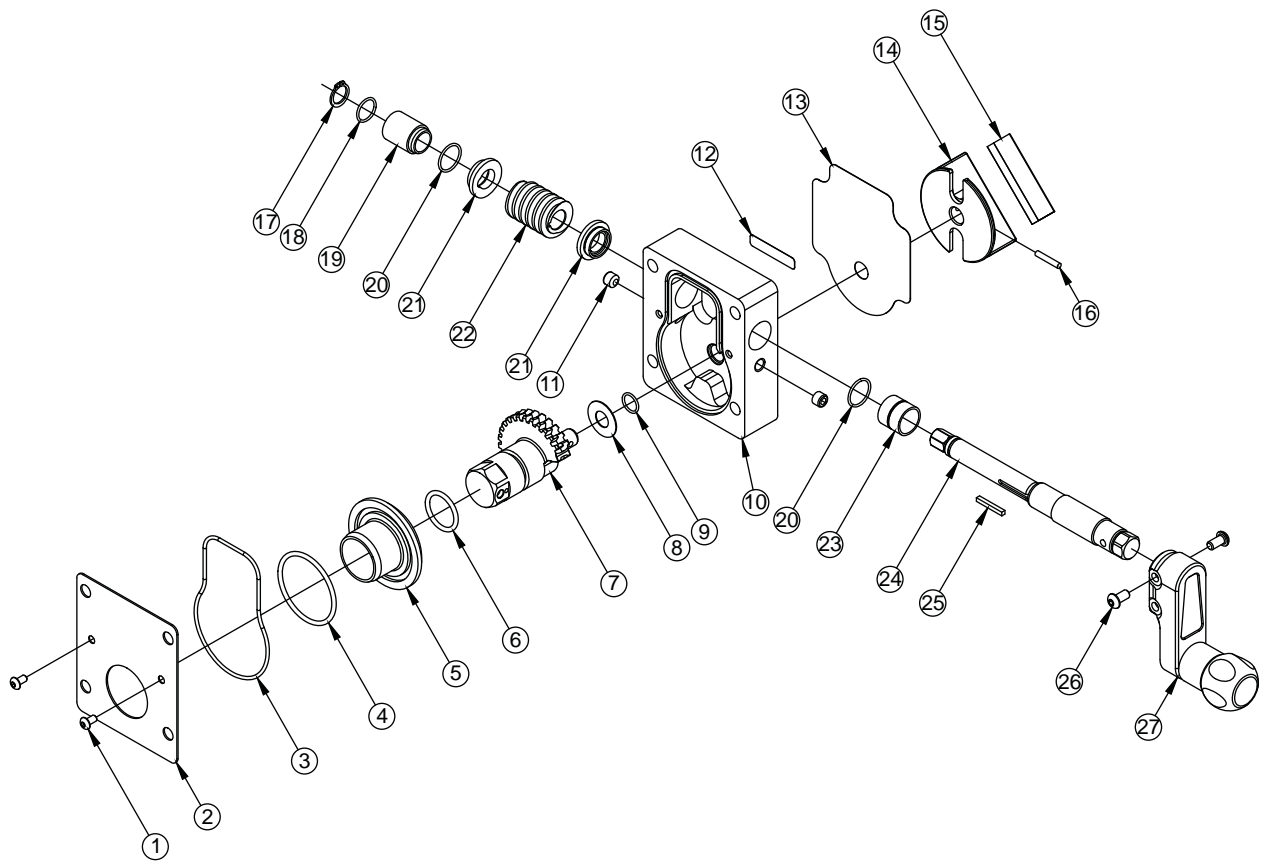

ITEM	DESCRIPTION	QTY	PART #
1	10-24 X 3/8 BUTTON HEAD SCREW	2	VT10-24BH375
2	GEARBOX COVER	1	A1030
3	O-RING-154	1	VO-154
4	O-RING-226	1	VO-226
5	GEAR SPACER	1	A1511
6	O-RING-214	1	VO-214
7	INTEGRAL WORM GEAR & TRUNNION (Top Crank)	1	A1501
	INTEGRAL WORM GEAR & TRUNNION GEARBOX ROTATED (Front Crank)		A1503
8	GEAR THRUST WASHER	1	A1502
9	O-RING-014	1	VO-014
10	GEARBOX 250PSI	1	A1506
11	3/8-16 X 5/16 SOCKET SET SCREW	2	VT37-16SS312
12	MODEL NUMBER LABEL	1	A1303
13	LABEL BALL INTAKE GEARBOX (Top Crank)	1	A1301
	LABEL BALL INTAKE GEARBOX ROTATED (Front Crank)		A1301R
	LABEL LEFT JBIV-LP TOP GEARBOX		A1314
	LABEL LEFT JBIV-LP FRONT GEARBOX		A1314R

ITEM	DESCRIPTION	QTY	PART #
14	POSITION INDICATOR WITH FLAG	1	A1523
	POSITION INDICATOR WITH FLAG		A1523R
15	POSITION INDICATOR LABEL	1	A1524
16	5/32 X 7/8 HDP SPIROL PIN	1	V1900
17	RETAINING RING	1	VR4275
18	O-RING-016	1	VO-016
19	LARGE BUSHING FOR SEALED GEARBOX	1	A1528
20	O-RING-018	2	VO-018
21	WORM THRUST WASHER	2	A1529
22	12 DP WORM - DEGREASED	1	X220
23	SMALL BUSHING FOR SEALED GEARBOX	1	A1527
24	SHAFT FOR SEALED GEARBOX	1	A1533
25	KEY	1	X225
26	3/8-16 X 1-1/2 BUTTON HEAD SCREW	1	VT37-16BH1.5
27	CRANK WITH KNOB SUBASSEMBLY	1	A1629

6.5 AIR VENT/DRAIN [B] EXPLODED VIEW AND PARTS LIST

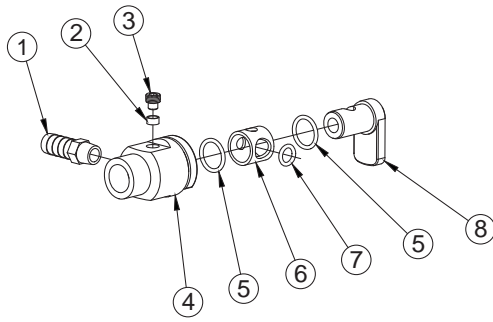

Replacement Kit - A1621-KIT

ITEM	DESCRIPTION	QTY	PART #
1	1/2" BARB X 1/4"NPTM NIPPLE	1	XX329
2	FOLLOWER	1	U251
3	3/8-24 X 3/8 DOG POINT	1	H515
4	DRAIN HOUSING	1	A1543
5	O-RING 115	2	VO-115
6	DRAIN SLEEVE	1	A1541
7	O-RING-110	1	VO-110
8	DRAIN LEVER	1	A1542

7.0 TROUBLE SHOOTING

SYMPTOM	POSSIBLE CAUSE	REMEDY
Leaks	Debris or damage in seal area	Clean out debris or replace damaged parts
Binding, Erratic operation	Low Voltage (see below)	See Below
Power LED on but no operation	Low voltage due to: -wire gage too small -wire length too long -poor connection -inadequate apparatus electrical system	Check connections and wiring per section 4.3
LED D6 on motor board blinks rapidly when button is pressed	Loose encoder connection	Replace Motor Sub Assembly
	Bad motor encoder	Replace Motor Sub Assembly
No Power LED	Polarity reversed or poor connection	Check wiring and correct polarity
OPEN & CLOSE LED blink every 4 seconds	No communication with Valve Motor	Check Blue & White communication wiring

8.0 TEN YEAR EXTENDED WARRANTY FOR JBIV-LP SERIES VALVES

Task Force Tips, Inc., 3701 Innovation Way, Valparaiso, Indiana 46383-9327 USA (“TFT”) warrants to the original purchaser of its Low Profile Ball Intake Valve (“equipment”), and to anyone to whom it is transferred, that the Low Profile Jumbo Intake Valve series includes a 10 year warranty against manufacturing defects and corrosion affecting the valve’s operational performance.

TFT’s obligation under this warranty is specifically limited to replacing or repairing the equipment (or its parts) which are shown by TFT’s examination to be in a defective condition attributable to TFT. To qualify for this limited warranty, the claimant must return the equipment to TFT, at 3701 Innovation Way, Valparaiso, Indiana 46383-9327 USA, within a reasonable time after discovery of the defect. TFT will examine the equipment. If TFT determines that there is a defect attributable to it, TFT will correct the problem within a reasonable time. If the equipment is covered by this limited warranty, TFT will assume the expenses of repair.

If any defect attributable to TFT under this limited warranty cannot be reasonably cured by repair or replacement, TFT may elect to refund the purchase price of the equipment, less reasonable depreciation, in complete discharge of its obligations under this limited warranty. If TFT makes this election, claimant shall return the equipment to TFT free and clear of any liens and encumbrances.

This is a limited warranty. The original purchaser of the equipment, any person to whom it is transferred, and any person who is an intended or unintended beneficiary of the equipment, shall not be entitled to recover from TFT any consequential or incidental damages for injury to person and/or property resulting from any defective equipment manufactured or assembled by TFT. It is agreed and understood that the price stated for the equipment is in part consideration for limiting TFT’s liability. Some states do not allow the exclusion or limitation of incidental or consequential damages, so the above may not apply to you.

TFT shall have no obligation under this limited warranty if the equipment is, or has been, misused or neglected (including failure to provide reasonable maintenance) or if there have been accidents to the equipment or if it has been repaired or altered by someone else.

THIS IS A LIMITED EXPRESS WARRANTY ONLY. TFT EXPRESSLY DISCLAIMS WITH RESPECT TO THE EQUIPMENT ALL IMPLIED WARRANTIES OF MERCHANTABILITY AND ALL IMPLIED WARRANTIES OF FITNESS FOR A PARTICULAR PURPOSE. THERE IS NO WARRANTY OF ANY NATURE MADE BY TFT BEYOND THAT STATED IN THIS DOCUMENT.

This limited warranty gives you specific legal rights, and you may also have other rights which vary from state to state.

9.0 MAINTENANCE

TFT appliances are designed and manufactured to be damage resistant and require minimal maintenance. However, as the primary firefighting tool upon which your life depends, it should be treated accordingly. Do not drop or throw equipment.

This valve should be disconnected, cleaned and visually inspected inside and out at least quarterly for proper function per NFPA 1962 section 8.2, or as water quality and use may require. Moving parts such as handles, valve ball and couplings should be checked for smooth and free operation. Seals shall be greased as needed with a silicone-based grease such as Dow Corning 112. Any scrapes that expose bare aluminum should be cleaned and touched up with enamel paint such as Rust-Oleum. Replace any missing or damaged parts before returning to service. Any repaired device must be tested before being placed in service.

9.1 SERVICE TESTING

In accordance with NFPA 1962 (2013), appliances must be tested a minimum of annually. Appliances failing any part of this test must be removed from service, repaired and retested upon completion of the repair.

9.1.1 HYDRAULIC TEST

1. The appliance being tested shall be positioned in a protective device or cover capable of holding the appliance and tested to a minimum hydrostatic pressure of 300 psi (20.7 bar or 2070 kPa).
2. Test caps capable of withstanding the required hydrostatic pressure shall be attached to openings, and a device capable of exerting the required hydrostatic pressure shall be attached to the appliance.
3. Appliances with relief valves shall have the relief valve outlet blanked off or otherwise closed during the test.
4. All air shall be bled from the system.
5. The gauge pressure shall be increased by 50 psi (3.45 bar or 345 kPa) increments and held for 30 seconds at each pressure up to the maximum pressure for which the appliance is being tested and held for 1 minute without leakage.

9.1.2 RELIEF VALVE TEST

1. Hydrostatic testing of the appliance shall be conducted prior to testing the relief valve.
2. The relief valve shall be tested separately from any device it is connected to.
3. The relief valve shall be set to its lowest setting and pressurized.
4. If the relief valve does not operate at or below a pressure 10 percent over the setting, the test shall be discontinued and the relief valve repaired or replaced.
5. A calibrated test gauge shall be used to verify the setting.
6. After successful completion of the relief valve test, the relief valve shall be reset to the pressure designated by the authority having jurisdiction.
7. The final setting of the relief valve shall be confirmed by pressure testing.

9.1.3 SHUTOFF VALVE TEST

1. If the appliance has a shutoff valve, the intake side of the shutoff valve shall be hydrostatically pressurized to the maximum working pressure of the appliance with the valve in the shutoff position.
2. There shall be no leakage through the valve.
3. A water flow through the fire hose appliance at 100 psi (6.9 bar or 690 kPa) shall be established.
4. The valve shall be closed and reopened twice and shall operate smoothly without evidence of binding or other problems.

9.1.4 RECORDS

A record of testing and repairs must be maintained from the time the appliance is purchased until it is discarded. Each TFT appliance is engraved with a unique serial number which, if so desired, can be used to identify appliance for documentation purposes.

The following information, if applicable, must be included on the test record for each appliance:

1. Assigned identification number
2. Manufacturer
3. Product or model designation
4. Vendor
5. Warranty
6. Hose connection size
7. Maximum operating pressure
8. Flow rate or range
9. Date received and date put in service
10. Date of each service test and service test results
11. Damage and repairs, including who made the repairs and the cost of repair parts
12. Reason removed from service

9.2 CRANKSHAFT OVERRIDE AND REPLACEMENT

The crankshaft includes an intentional shear joint to protect the gear train from overload, costly repairs and loss of service. The magnitude of torque required to shear the crankshaft is several times greater than the torque typically needed to operate the valve at maximum operating pressure. If the crankshaft breaks during use, this is an indication that either there is something obstructing the half ball internally or the crank shaft has been abused (e.g. used as a step for climbing).

9.2.1 CRANKSHAFT OVERRIDE

In an emergency, the opposite side of the crankshaft can be turned using a 1/2" wrench or hex socket. This allows the valve to be open or closed until the crankshaft is replaced. To prevent loss of the 1/8" square key on the crankshaft, do not allow the crankshaft to slide out of gearbox until a replacement crankshaft is acquired. It is important not to rely on this as a long-term method of operation.

9.2.2 DIAGNOSIS

To diagnose the problem that caused the crankshaft to fail, complete the following steps:

1. Close upstream water supply. If possible, relieve pressure leading up to valve.
2. Locate 1/2" hex where crankshaft protrudes from opposite side of gearbox.
3. Gently turn crank shaft away from travel stop using a 1/2" hex wrench. Do not attempt to shock crankshaft free and do not exceed 45 ft-lb (61 Nm) of torque.
4. If crankshaft will not rotate, then half ball is likely obstructed. Only after relieving pressure on flanged joint, unbolt valve. Clear any obstructions and evaluate whether repair is needed before returning to service.
5. If crankshaft is able to rotate, cycle the valve several times from open to closed to determine whether the crankshaft binds at any place between the travel stops. If crankshaft binds, consult Task Force Tips Service Department to determine the appropriate repairs.
6. If crankshaft rotates freely after clearing any obstructions, then a replacement crank shaft may be ordered from Task Force Tips and replaced as described below.

9.2.3 CRANKSHAFT REPLACEMENT

A broken crankshaft can be replaced at any time by completing the following steps, regardless of whether or not the upstream water supply is pressurized. Referring to index numbers shown in section 6.3, follow the steps below:

1. Remove external retaining ring (index 17) adjacent to 1/2" hex on crankshaft. Do not over-expand the retaining ring.
2. Using a punch or Phillips head screwdriver at least 6" in length, gently push on dimple in 1/2" hex end of crankshaft (index 24). Continue to push crankshaft through until it protrudes from opposite side of gearbox.
3. Grab broken end of crankshaft and pull out of gearbox. As crankshaft is withdrawn, grasp small key (index 25) on shaft so it does not get lost.
4. If 1/8" square x 1" long key is not visible in shaft, it has likely fallen into gearbox bore and must be removed before installing new crankshaft. If square key is visible in gearbox bore, slide it out of bore. Needle-nose pliers may be helpful depending on position of key in bore.
5. Verify polymer bushings (index 23 and 19) are still seated in bores on each side of gearbox. If not, locate and replace bushings.
6. Look through gearbox bore and note approximate orientation of square keyway in worm (index 22). Verify round notch in thrust washer (index 20) is aligned with square keyway in worm.
7. Prepare new crankshaft by applying small dab of grease to keyway and seating 1/8" square x 1" long key into keyway. Grease will keep key in place during assembly.
8. Slide shaft into gearbox with key orientation the same as keyway in worm. Rotate shaft slightly in alternating directions until key finds keyway, then push shaft in until it stops. Retaining ring groove and 1/2" hex should be protruding through opposite side of gearbox. If hex is not visible, it may be necessary to slide polymer bushing back into gearbox bore.
9. Install retaining ring (index 17) onto shaft. Do not over-expand the retaining ring.

10.0 REPAIR

Factory service is available with repair time seldom exceeding one day in our facility. Factory serviced appliances are repaired by experienced technicians to original specifications, fully tested and promptly returned. Repair charges for non-warranty items are minimal. Any returns should include a note as to the nature of the problem and whom to reach in case of questions.

Repair parts and service procedures are available for those wishing to perform their own repairs. Task Force Tips assumes no liability for damage to equipment or injury to personnel that is a result of user service. Contact the factory or visit the web site at www.tft.com for parts lists, exploded views, test procedures and troubleshooting guides.

For additional information on care, maintenance and testing, refer to: NFPA 1962: Standard for the Care, Use, Inspection, Service Testing, and Replacement of Fire Hose, Couplings, Nozzles, and Fire Hose Appliances, 2013 Edition



Any alterations to the device and its markings could diminish safety and constitute a misuse of this product.

11.0 ANSWERS TO YOUR QUESTIONS

We appreciate the opportunity of serving you and making your job easier. If you have any problems or questions, our toll-free "Hydraulics Hotline", 800-348-2686, is normally available to you 24 hours a day, 7 days a week.

12.0 TEMPLATES

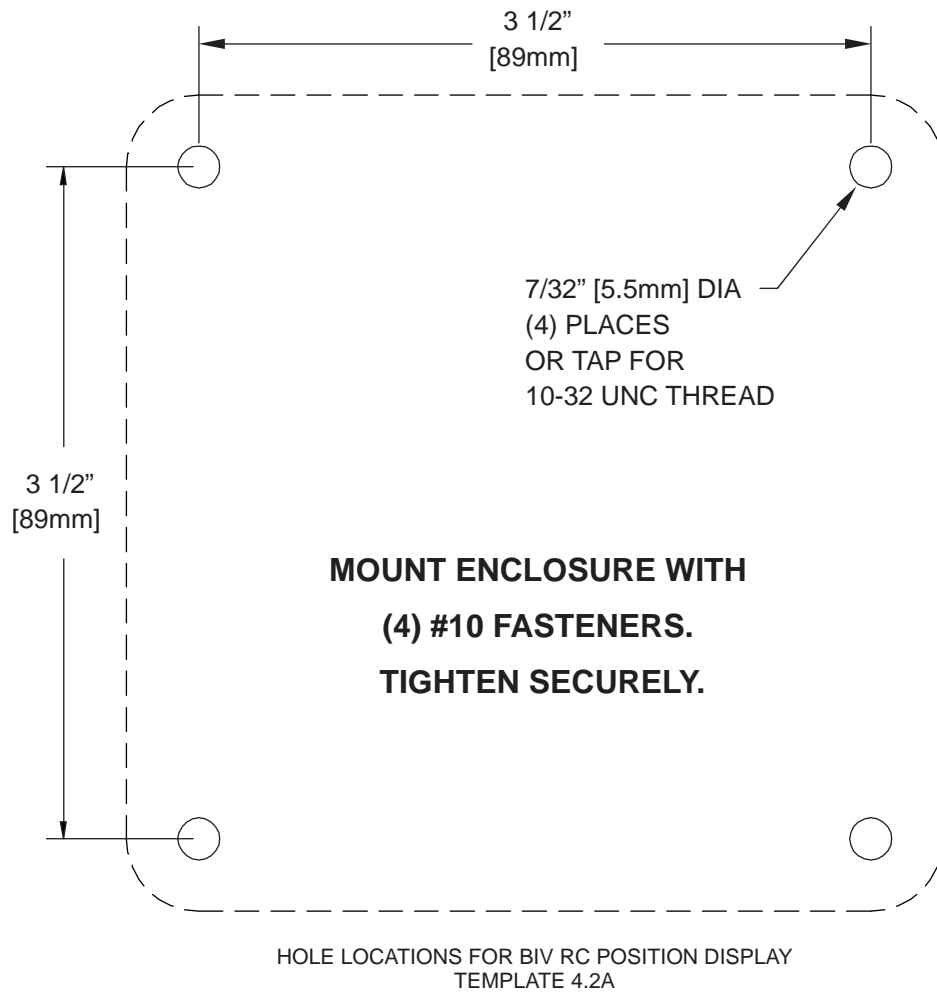

**INSTALLER CAN USE
FLAT OR #4 SCREWS
TO STOP ROTATION**

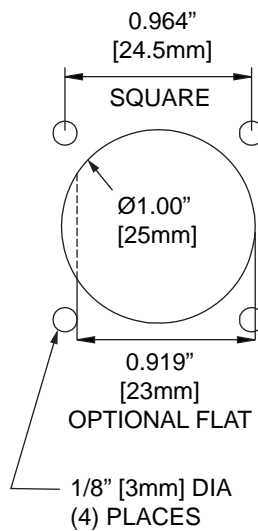

HOLE LOCATIONS FOR
QUICK CONNECT PLUG
TEMPLATE 4.2B

13.0 INSPECTION CHECKLIST

BEFORE EACH USE,

- Fire hoses must be securely attached to appliances.
- Appliances must also be inspected to the following checklist.

BEFORE BEING PLACED BACK IN SERVICE,

1. All valves open and close smoothly and fully.
2. The waterway is clear of obstructions.
3. There is no damage to any thread or other type connection.
4. The pressure setting of the relief valve, if any, is set correctly.
5. All locks and hold-down devices work properly.
6. Internal gaskets are in accordance with NFPA 1962 (2013) Section 7.2.
7. There is no damage to the appliance (e.g., dents, cracks, corrosion, or other defects that could impair operation).
8. All swiveling connections rotate freely.
9. There are no missing parts or components.
10. The marking for maximum operating pressure is visible.
11. There are no missing, broken, or worn lugs on couplings.

NFPA 1962: Standard for the care, use, inspection, service testing, and replacement of fire hose, couplings, nozzles and fire hose appliances. (2013 ed., Section 6.2.1). Quincy, MA: National Fire Protection Agency.



Any appliance failing any part of the inspection checklist is unsafe and must have the problem corrected before use. Operating an appliance that fails any of the above inspections is a misuse of this equipment.