

# MANUAL: Pressure Relief Valve

## INSTRUCTIONS FOR SAFE OPERATION AND MAINTENANCE

### ⚠ WARNING

Read instruction manual before use. Operation of this device without understanding the manual and receiving proper training is a misuse of this equipment. A person who has not read and understood all operating and safety instructions is not qualified to operate the Pressure Relief Valve.

This instruction manual is intended to familiarize firefighters and maintenance personnel with the operation, servicing and safety procedures associated with the Pressure Relief Valve.

This manual should be kept available to all operating and maintenance personnel.

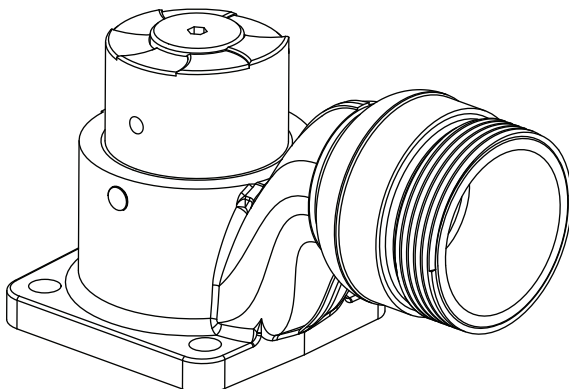
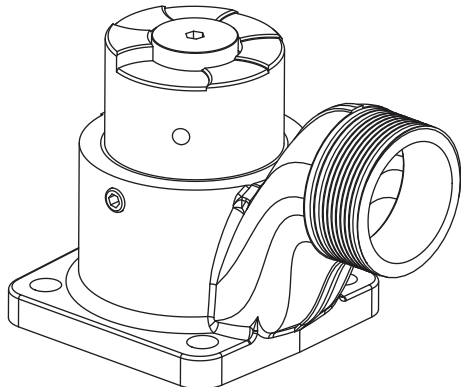
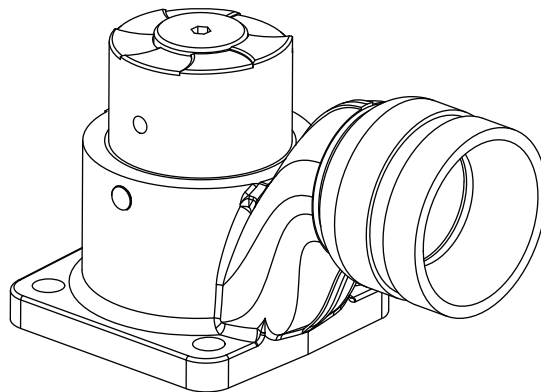
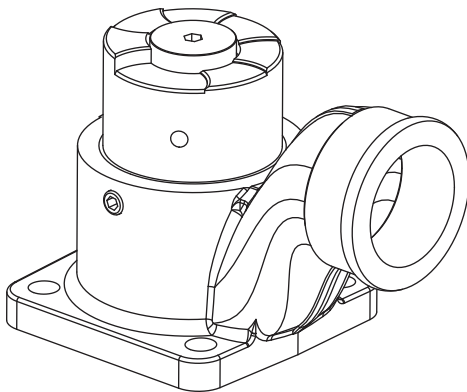

### ⚠ DANGER

#### PERSONAL RESPONSIBILITY CODE

The member companies of FEMSA that provide emergency response equipment and services want responders to know and understand the following:

1. Firefighting and Emergency Response are inherently dangerous activities requiring proper training in their hazards and the use of extreme caution at all times.
2. It is your responsibility to read and understand any user's instructions, including purpose and limitations, provided with any piece of equipment you may be called upon to use.
3. It is your responsibility to know that you have been properly trained in Firefighting and /or Emergency Response and in the use, precautions, and care of any equipment you may be called upon to use.
4. It is your responsibility to be in proper physical condition and to maintain the personal skill level required to operate any equipment you may be called upon to use.
5. It is your responsibility to know that your equipment is in operable condition and has been maintained in accordance with the manufacturer's instructions.
6. Failure to follow these guidelines may result in death, burns or other severe injury.



Fire and Emergency Manufacturers and Service Association  
P.O. Box 147, Lynnfield, MA 01940 • www.FEMSA.org

## Table Of Contents

1.0 MEANING OF SIGNAL WORDS	5.0 DRAWING AND PARTS LIST
2.0 GENERAL INFORMATION	6.0 MAINTENANCE AND INSPECTION
3.0 RELIEF VALVE PRESSURE SETTING	7.0 WARRANTY
4.0 RELIEF VALVE FLOW vs PRESSURE CURVE	

### 1.0 MEANING OF SAFETY SIGNAL WORDS

A safety related message is identified by a safety alert symbol and a signal word to indicate the level of risk involved with a particular hazard. Per ANSI standard Z535.6-2006, the definitions of the four signal words are as follows:

**⚠ DANGER**

**DANGER** indicates a hazardous situation which, if not avoided, will result in death or serious injury.

**⚠ WARNING**

**WARNING** indicates a hazardous situation which, if not avoided, could result in death or serious injury.

**⚠ CAUTION**

**CAUTION** indicates a potentially hazardous situation which, if not avoided, may result in minor or moderate injury.

**NOTICE**

**NOTICE** is used to address practices not related to personal injury.

### 2.0 GENERAL INFORMATION

The Pressure Relief Valve may be set to any pressure between 50 and 200 psi. Its function is to protect the pump and the supply hose from excess pressure. The relief valve may be mounted with its opening facing the front, back, right or left. A section of tubing or pipe may be mounted on the round spout to route the water in any direction. To install the Pressure Relief Valve;

- 1) Install the O-ring in the groove on the Pressure Relief Valve.
- 2) Install four 7/16" bolts through the Pressure Relief Valve flange. Use a drop of thread locking compound on the threads of the bolts to prevent them from coming loose.

### 3.0 RELIEF VALVE PRESSURE SETTING

To set the relief valve pressure turn the adjusting screw on the relief valve housing until the surface of the screw is even with the desired pressure. Do not cap or plug discharge opening.

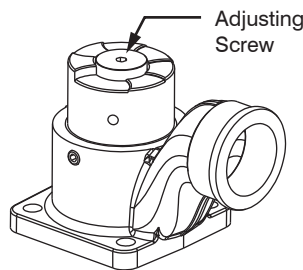
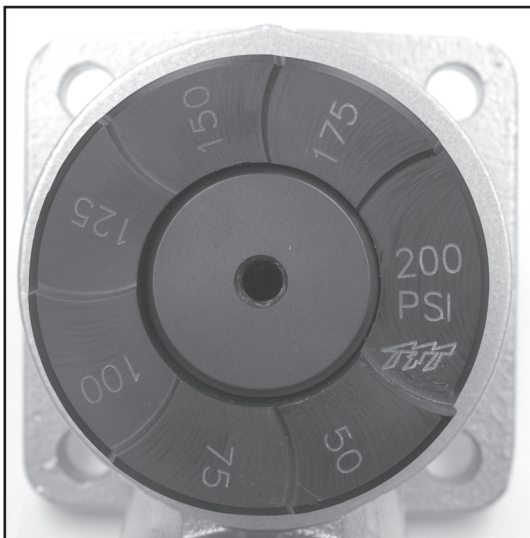

**⚠ WARNING**

The Pressure Relief Valve will open to relieve excess pressure but it may not have enough flow capacity to protect against large pressure spikes such as those caused by water hammer. Excess pressure can cause equipment failure and directly or indirectly lead to injury or death. Always operate valves slowly to avoid the risk of water hammer.

## 4.0 RELIEF VALVE FLOW vs. PRESSURE CURVE

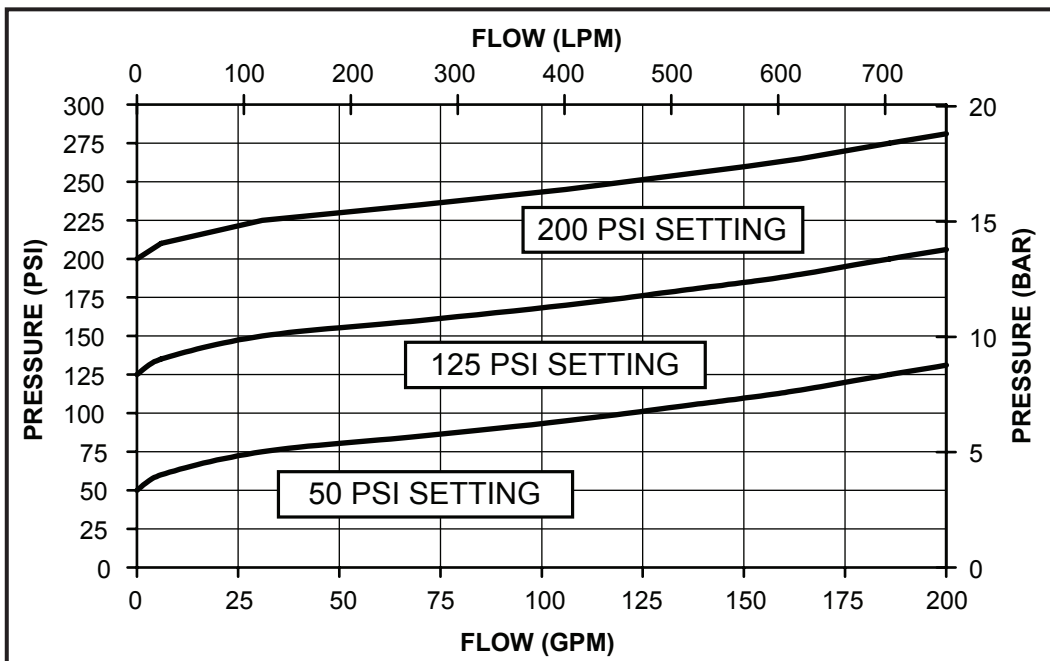

PRESSURE RELIEF VALVE PERFORMANCE

## 5.0 DRAWING AND PARTS LIST

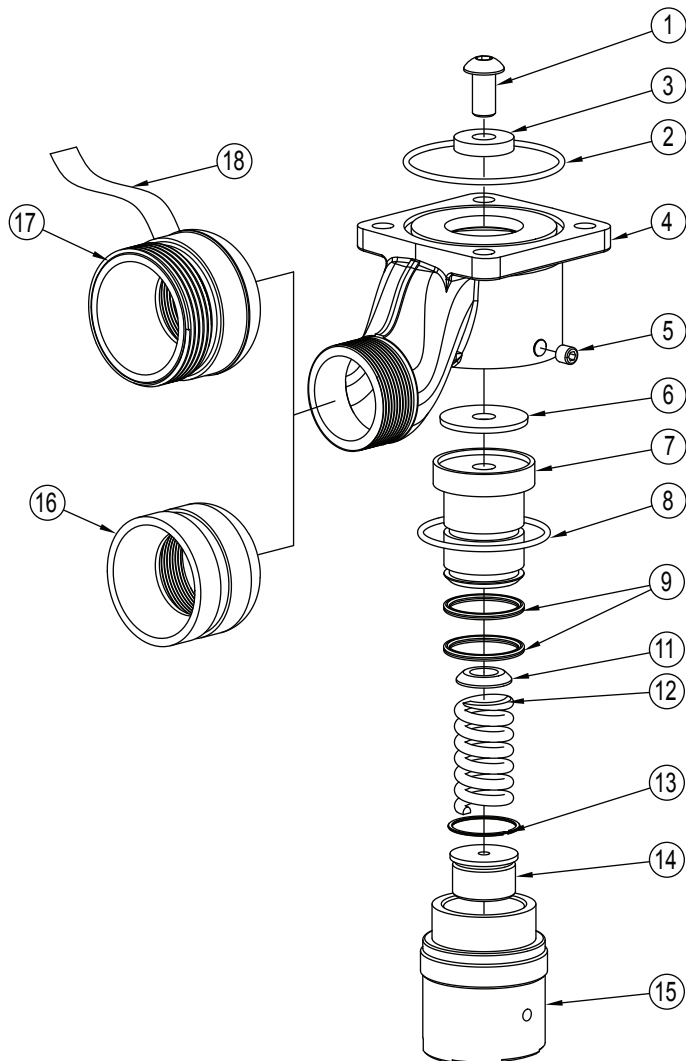

Pressure Relief Valve 50 - 200 PSI

DESCRIPTION	QTY	PART #
1 1/2-13 X 1.0 Button Head Cap Screw	1	VT50-13BH1.0
2 O-RING-236 3-1/4 ID 1/8 C/S	1	VO-236
3 Debris Washer	1	A1169
4 HOUSING W/OUT THDS	1	A1150***
5 5/16-18 X 3/8 Socket Set Screw Cup Point	1	VT31-18SS375
6 Valve Seat	1	A1168
7 Piston -Hardcoat	1	A1160
8 O-RING-231 2-5/8 ID 1/8 C/S	1	VO-231
9 QUAD RING 422 1.5 ID X 1/8 C/S	2	VOQ-4222
11 Spring Seat	1	A1166
12 Relief Spring	1	A1170
13 Smalley Ring	1	V4210
14 Adjusting Screw	1	A1167
15 Spring Housing	1	A1164
16 PRV Adaptor 2.0"NPT X 2.5" Victaulic	1	A1851-1
17 PRV Adaptor 2.0"NPT X 2.5"NH	1	A1861-1
18 PRV "DO NOT CAP" Label	1	A1865L

\*\*\* Index 4 Housing Choices

A1150	Housing with Waterous / Hale hole pattern. (TFT Standard) Plain discharge.
A1150PH	Housing with Waterous / Hale hole pattern. 2" NPT male discharge.
A1151	Housing with Darley hole pattern. Plain discharge.
A1151PH	Housing with Darley hole pattern. 2" NPT male discharge.

## 6.0 MAINTENANCE AND INSPECTION

The Pressure Relief Valve requires no routine maintenance but should be tested regularly. Since the Pressure Relief Valve may not need to open in normal use it is important that it be inspected at least quarterly for proper function per NFPA 1962 section 8.2. In particular assure that:

- There is no damage such as cracks or dents
- There is no corrosion
- Setting indications are readable
- The waterway is clear of obstructions
- The valve opens at the set pressure (see below for test instructions)

If any problems are found, the Pressure Relief Valve should be removed from service until the problem is corrected. Any repaired Pressure Relief Valve must be tested before being placed in service.

**▲ WARNING** The Pressure Relief Valve may be damaged if frozen while containing significant amounts of water. Such damage may be difficult to detect visually and can lead to possible injury or death. Any time the Pressure Relief Valve is subject to possible damage due to freezing, it must be hydrostatically tested by qualified personnel before being considered safe for use.

It is important that your pressure relief valve is functioning properly at all times while in service. A properly functioning PRV prevents dangerous situations and reduces possible injury. In order to ensure the PRV is functioning properly, it should be tested regularly. NFPA 1962 Sections 8.2 and 8.3 set forth the minimum standards and procedures for use of these valves. It is strongly recommended that you read and follow these procedures. In addition, TFT recommends testing the PRV semi-annually to the following test procedures.

1. Set up the line with a pressure gage upstream from the appliance and pressure relief valve.
2. Make sure the PRV is set to your operating pressure, and close all appliance outlets.
3. Fill the appliance with water using pressure less than where the PRV is set, being sure to bleed all air out of the system.
4. Carefully increase the pressure on the appliance to the set pressure. Check to see if the valve has opened to allow water to escape. If the valve has not opened and there is no water, increase the pressure by 5psi. If the valve has not opened, the valve has failed and should be taken out of service immediately

Any valves taken out of service due to failure should be returned to the factory for repair or replacement. If you have any questions regarding the testing or maintenance of your pressure relief valve, please call Task Force Tips at 800-348-2686.

## 7.0 WARRANTY

Task Force Tips, Inc., 3701 Innovation Way, Valparaiso, IN 46383-9327 USA ("TFT") warrants to the original purchaser of its Pressure Relief Valve ("equipment"), and to anyone to whom it is transferred, that the equipment shall be free from defects in material and workmanship during the five (5) year period from the date of purchase.

TFT's obligation under this warranty is specifically limited to replacing or repairing the equipment (or its parts) which are shown by TFT's examination to be in a defective condition attributable to TFT. To qualify for this limited warranty, the claimant must return the equipment to TFT, at 3701 Innovation Way, Valparaiso, IN 46383-9327 USA, within a reasonable time after discovery of the defect. TFT will examine the equipment. If TFT determines that there is a defect attributable to it, TFT will correct the problem within a reasonable time. If the equipment is covered by this limited warranty, TFT will assume the expenses of repair.

If any defect attributable to TFT under this limited warranty cannot be reasonably cured by repair or replacement, TFT may elect to refund the purchase price of the equipment, less reasonable depreciation, in complete discharge of its obligations under this limited warranty. If TFT makes this election, claimant shall return the equipment to TFT free and clear of any liens and encumbrances.

This is a limited warranty. The original purchaser of the equipment, any person to whom it is transferred, and any person who is an intended or unintended beneficiary of the equipment, shall not be entitled to recover from TFT any consequential or incidental damages for injury to person and/or property resulting from any defective equipment manufactured or assembled by TFT. It is agreed and understood that the price stated for the equipment is in part consideration for limiting TFT's liability. Some states do not allow the exclusion or limitation of incidental or consequential damages, so the above may not apply to you.

TFT shall have no obligation under this limited warranty if the equipment is, or has been, misused or neglected (including failure to provide reasonable maintenance) or if there have been accidents to the equipment or if it has been repaired or altered by someone else.

THIS IS A LIMITED EXPRESS WARRANTY ONLY. TFT EXPRESSLY DISCLAIMS WITH RESPECT TO THE EQUIPMENT ALL IMPLIED WARRANTIES OF MERCHANTABILITY AND ALL IMPLIED WARRANTIES OF FITNESS FOR A PARTICULAR PURPOSE. THERE IS NO WARRANTY OF ANY NATURE MADE BY TFT BEYOND THAT STATED IN THIS DOCUMENT.

This limited warranty gives you specific legal rights, and you may also have other rights which vary from state to state.

**TASK FORCE TIPS, INC.**  
MADE IN USA • [www.tft.com](http://www.tft.com)

**3701 Innovation Way, Valparaiso, IN 46383-9327 USA**  
**800-348-2686 • 219- 462-6161 • Fax 219-464-7155**