



MANUAL: Ball Intake Valve™

INSTRUCTIONS FOR SAFE OPERATION AND MAINTENANCE

⚠ WARNING

Read instruction manual before use. Operation of this device without understanding the manual and receiving proper training is a misuse of this equipment. A person who has not read and understood all operating and safety instructions is not qualified to operate the Ball Intake Valve.

This instruction manual is intended to familiarize firefighters and maintenance personnel with the operation, servicing and safety procedures associated with the Ball Intake Valve.

This manual should be kept available to all operating and maintenance personnel.

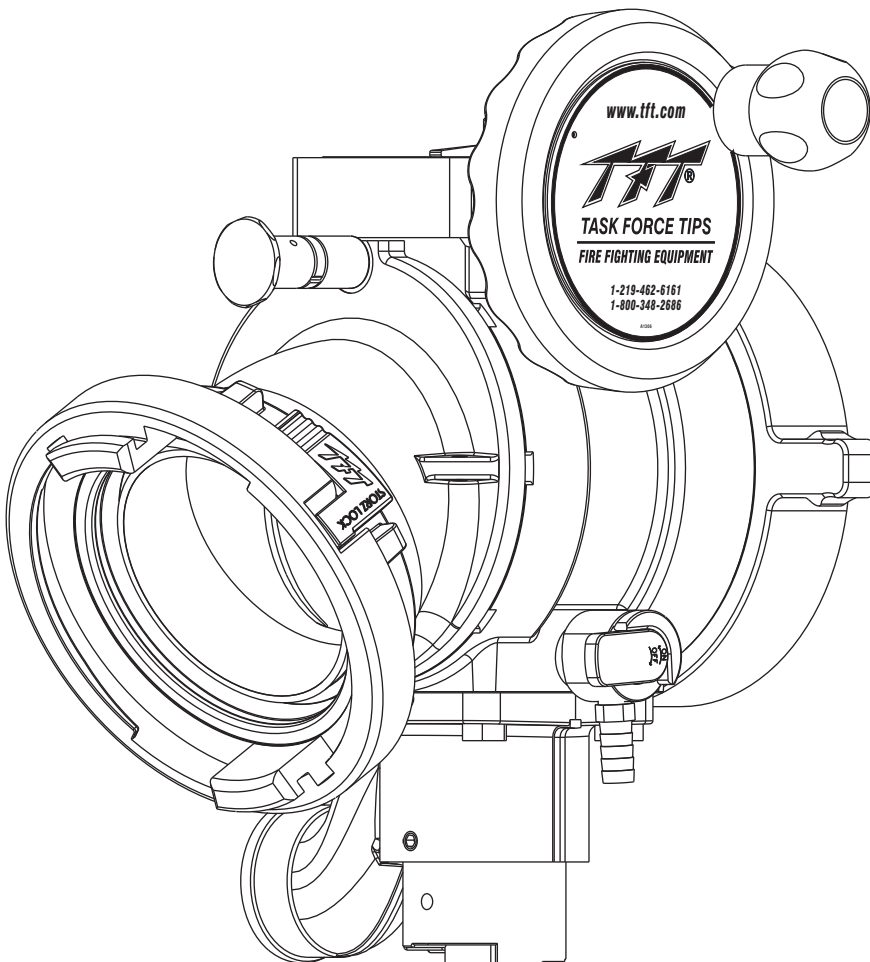

OPERATING RANGE:
Pressure Max 250 PSI
Pressure Min Full Vac.

**Hydrostatic
Proof Test:**
900 PSI

TASK FORCE TIPS, Inc.
MADE IN USA • www.tft.com

2800 E. Evans Ave, Valparaiso, IN 46383-6940 USA
800-348-2686 • 219-462-6161 • Fax 219-464-7155

TABLE OF CONTENTS

1.0 MEANING OF SIGNAL WORDS	6.0 AIR VENT AND WATER DRAIN
2.0 SAFETY	7.0 PRESSURE RELIEF VALVE
3.0 GENERAL INFORMATION	7.1 SETTING PRESSURE
3.1 CORROSION	7.2 FLOW vs. PRESSURE CURVE
3.2 USE WITH SALT WATER	8.0 DRAWINGS AND PARTS LISTS
4.0 INSTALLATION	9.0 MAINTENANCE
4.1 MOUNTING ON TRUCK	10.0 BALL INTAKE VALVE PRESSURE LOSS
4.2 CHANGING HANDWHEEL TO LEFT SIDE	11.0 WARRANTY
5.0 USE	
5.1 INTAKE ELBOW	
5.2 VALVE POSITION INDICATOR	
5.3 STORZ SUCTION GASKET REQUEST	

1.0 MEANING OF SIGNAL WORDS

A safety related message is identified by a safety alert symbol and a signal word to indicate the level of risk involved with a particular hazard. Per ANSI standard Z535.4-1998 the definitions of the three signal words are as follows:

DANGER

DANGER indicates an imminently hazardous situation which, if not avoided, will result in death or serious injury.

WARNING

WARNING indicates a potentially hazardous situation which, if not avoided, could result in death or serious injury.

CAUTION

CAUTION indicates a potentially hazardous situation which, if not avoided, may result in minor or moderate injury.

2.0 SAFETY

WARNING

Injury or death can result from burst hoses and fittings. Be sure the pressure relief valve is set at the proper pressure for the type of hose and equipment you are using. See NFPA 1961 and NFPA 1962.

WARNING

This equipment is intended for use by trained personnel for firefighting. Its use for other purposes may involve hazards not addressed by this manual. See appropriate guidance and training to reduce risk of injury.

WARNING

Kinks in supply hose may reduce water flow and cause injury or death to persons dependant on water flow. When this valve is used on a hydrant or fire truck it is recommended that it be used with an elbow to minimize risk of hoseline kinks.

CAUTION

Maximum operating pressure 250 PSI (17 bar). Do not exceed 250 PSI on either side of the valve.

CAUTION

Valve must be properly connected. Mismatched or damaged connectors may cause leaking or uncoupling under pressure and could cause injury.

3.0 GENERAL INFORMATION

The Ball Intake Valve is intended for use on the intake manifold of a fire engine. The valve is kept closed while the water supply from a hydrant or another pumper to the engine is being established. This prevents the pump from sucking air through the intake manifold and losing its prime. Once the supply hose is filled and under pressure, and the air has been vented from the hose, the valve may be opened to connect the pump to the water supply. An adjustable pressure relief valve mounted on the bottom of the valve opens to relieve any excess pressure that may damage the hose or the pump. The Task Force Tips Ball Inlet Valve has a unique patented half ball, with a thermo-plastic rubber seat, and acts much like a gate valve.

3.1 CORROSION

Hose couplings are attached using polymer bearing rings which provides electrical insulation to help prevent galvanic corrosion. In the past some valves were made of bare aluminum. Task Force Tips is using a three-step process to fight corrosion. The cast aluminum parts in this valve have been impregnated to fill the microscopic pores in the cast aluminum. The parts are then hard anodized, and finally powder coated, inside and out, to help prevent corrosion. The effects of corrosion can be minimized by good maintenance practice. See section 9.0 for maintenance.

3.2 USE WITH SALT WATER

Use with salt water is permissible provided valve is thoroughly cleaned with fresh water after each use. The service life of the valve may be shortened due to the effects of corrosion and is not covered under warranty.

4.0 INSTALLATION

4.1 MOUNTING ON TRUCKS

Screw the large coupling to the pump inlet manifold. The valve position indicator should be clearly visible, but need not be level.

4.2 CHANGING HAND WHEEL TO LEFT SIDE

The handwheel is shipped from the factory on the right hand side of the valve. The hand wheel can be switched to the left hand side for convenience or if it interferes with other equipment on the pump panel.

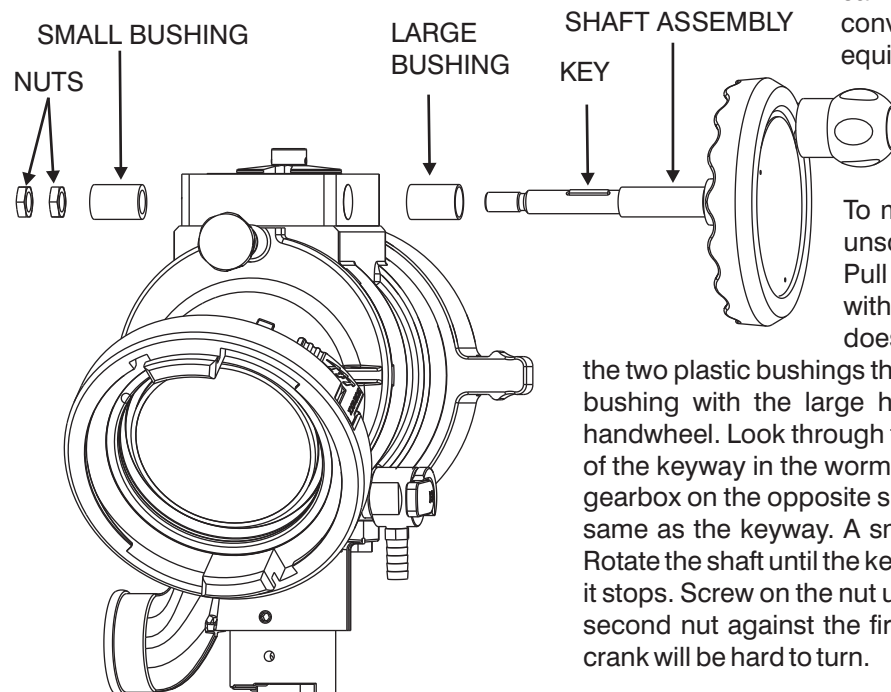

To move the hand wheel to the opposite side, unscrew the jam nuts on the end of the shaft. Pull the shaft out of the gear box. As the shaft is withdrawn, grasp the small key on the shaft so it does not fall and get lost. Remove and switch

the two plastic bushings that come out of the sides of the gearbox. The bushing with the large hole is installed on the same side as the handwheel. Look through the gear box and note approximate position of the keyway in the worm inside the gear box. Slide the shaft into the gearbox on the opposite side of the gear box with the key oriented the same as the keyway. A small dab of grease will keep the key place. Rotate the shaft until the key finds the keyway and push the shaft in until it stops. Screw on the nut until it is 1/6 turn past finger tight. Tighten the second nut against the first one. If you over tighten the first nut, the crank will be hard to turn.

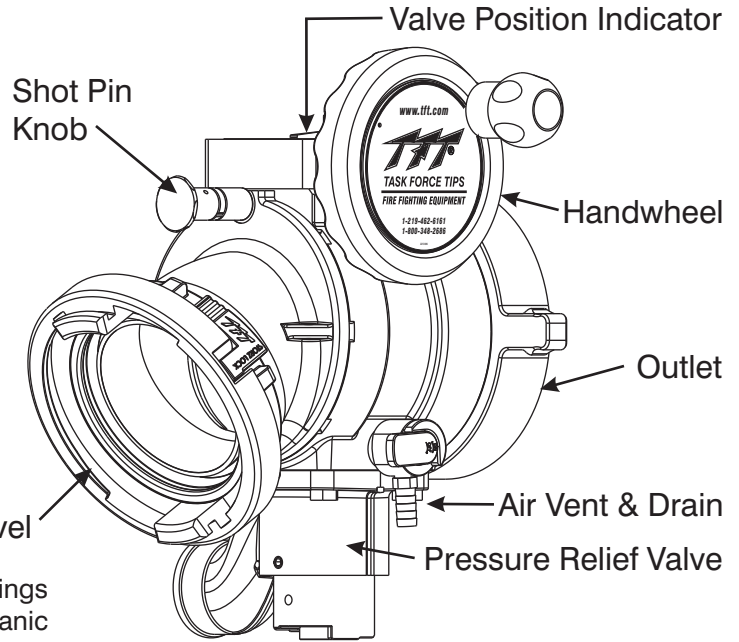

5.0 USE

5.1 INTAKE ELBOW

The intake elbow swivels 360 degrees to help prevent hose kinks, and make connection of suction lines easier. The intake can be turned forward or backward to help make connections in tight places if the water supply is in front of or behind the truck. To turn the elbow, pull the shot pin knob on top of the elbow. The elbow will lock into a detent every 45 degrees. There is a hole on the side of the elbow that can be used to attach the lanyard or chain of a cap by use of a key ring. The elbow may be swivelled to any of eight positions by pulling the shot pin knob.

5.2 VALVE POSITION INDICATOR

To open the valve turn the hand wheel until the valve position says "OPEN". To close the valve turn the hand wheel the opposite way until the valve position indicator says "CLOSED".

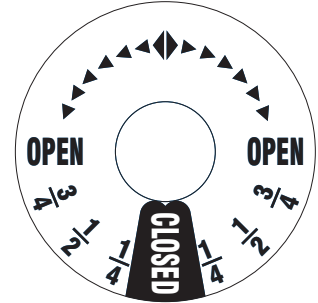

5.3 STORZ 'SUCTION GASKET' REQUEST

If your application of this product requires drafting, you may need a suction gasket, please call 1-800-348-2686 to receive a free suction gasket by mail.

Part Numbers: 4" STORZ - item # A4216, 5" STORZ - item # A4221

6.0 AIR VENT AND WATER DRAIN

This valve is equipped with an Air Vent/Drain which will allow the air to escape from the valve when the hose is charged. The Air Vent/Drain is opened by turning the knob counter clockwise and closed by turning it clockwise.

To drain the water out of the valve after use open the Air Vent/Drain. A 1/2" diameter plastic tube may be used to run the drain behind the pump panel.

7.0 PRESSURE RELIEF VALVE

CAUTION Loss of prime can interrupt water flow and cause injury or death. Always bleed out air with air valve to prevent possible loss of prime.

There is a pressure relief valve on the bottom side of the valve. It may be set to any pressure between 50 and 200 p.s.i.. Its function is to protect the pump and the supply hose from excess pressure. The relief valve may be mounted with its opening facing the front, back, right or left. A piece of hose or tubing may be mounted on the round spout to direct the water coming out of the relief valve away from the pump panel. To change the orientation of the relief valve, remove the four 7/16 bolts on the corners of the relief valve flange, orient the valve the way you want it, and replace the bolts. Use a drop of thread locking compound on the threads of the bolt to prevent them from coming loose.

7.1 RELIEF VALVE SETTING PRESSURE

To set the relief valve pressure turn the adjusting screw on the relief valve housing until the surface of the screw is even with the desired pressure. Do not cap or plug discharge opening.

7.2 RELIEF VALVE FLOW vs. PRESSURE CURVE PRESSURE RELIEF VALVE PERFORMANCE

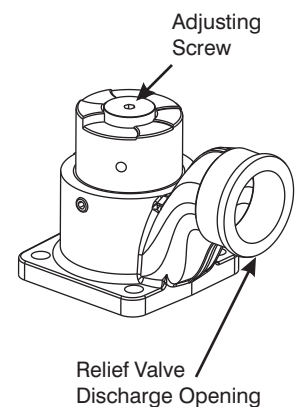
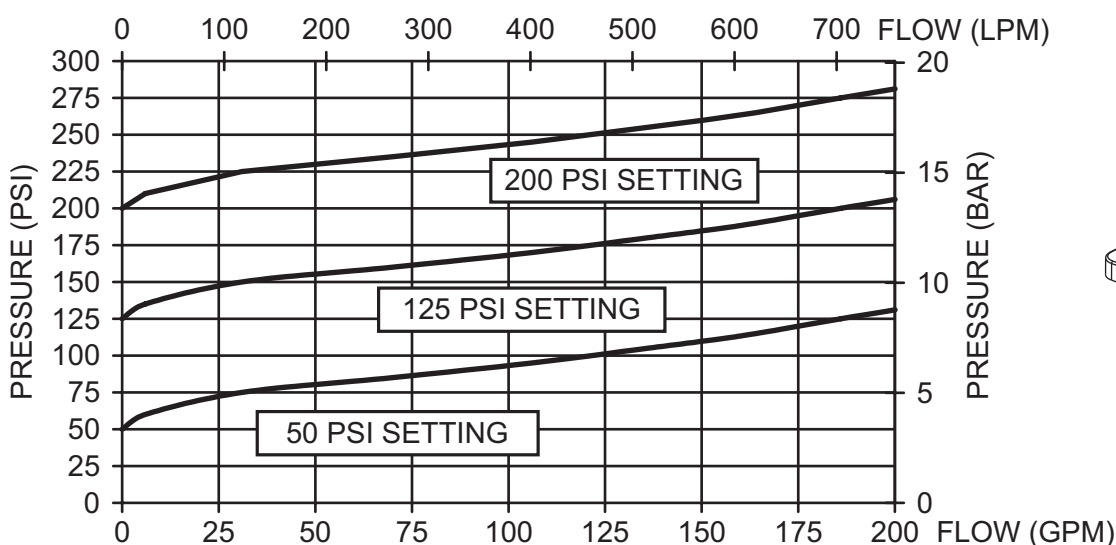

8.0 DRAWINGS AND PARTS LISTS

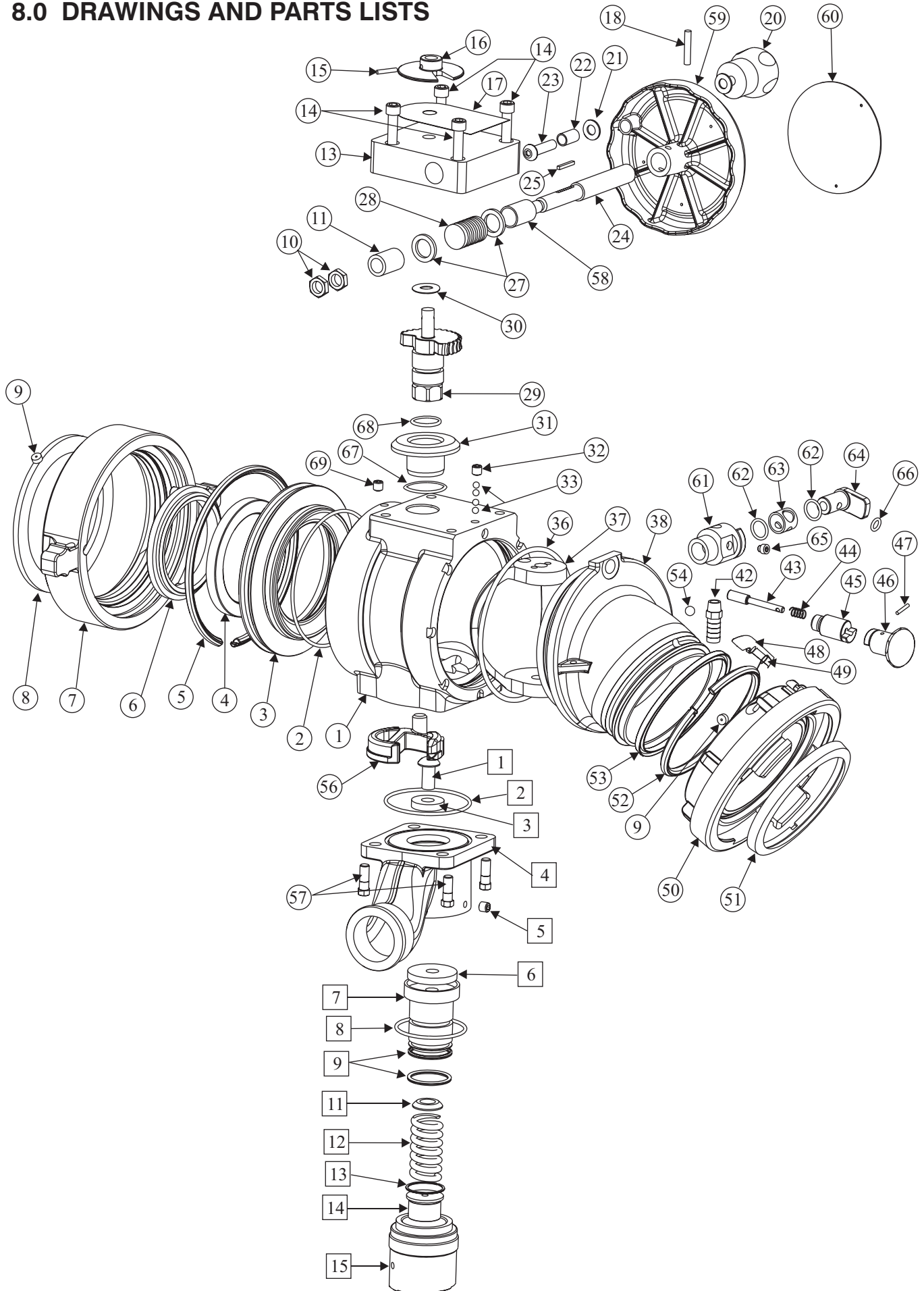

8.0 DRAWINGS AND PARTS LISTS

Ball Intake Valve Parts List

Index	Description	QTY	Part #
1	BGIV BODY - POWDER COAT	1	A1015
2	O-RING-161 5 1/2 ID X 3/32 C/S	1	VO-161
3	BACK RING STAINLESS STEEL	1	A1201S
4	VALVE SEAT	1	A1520
5	PLASTIC STRIP 7.00"	1	A1290
6	SEAL RETAINER	1	A1521S
7	COUPLING 5.0"NHF X PSF7.0-NFS	1	A1261NT
	COUPLING 6.0"NHF X PSF7.0-NFS	1	A1266NX
8	GASKET - 5.0" HOSE COUPLING	1	V3220
	GASKET - 6.0" HOSE COUPLING	1	V3240
9	PORT PLUG	1	A1299
10	1/2-20 JAM HEX NUT	2	VT50B20JNT
11	SMALL BUSHING	1	A1525
13	GEAR BOX	1	A1505
14	3/8-16 X 1 1/4 SOCKET HEAD CAP SCREW	4	VT37-16SH1.2
15	5/32 X 7/8 HDP SPIROL PIN #12437	1	V1900
16	POSITION INDICATOR	1	A1517
17	LABEL; BGIV GEARBOX	1	AL010
18	1/4 X 1-3/8 HDP SPIROL PN	1	VP250X1.375H
20	KNOB	1	A1512
21	WASHER .812 OD X .406 ID X .065 THICK	2	VW812X406-65
22	CRANK BUSHING	1	A1513
23	3/8-16 X 1.5 BUTTON HEAD CAP SCREW	1	VT37-16BH1.5
24	CRANK SHAFT	1	A1510
25	KEY, 1/8" X 1.00"	1	X225
27	THIN WASHER	2	A1530
28	12 DP WORM	1	X220
29	INTERNAL WORM GEAR TRUNNION	1	A1501
30	GEAR THRUST WASHER	1	A1502
31	GEAR SPACER	1	A1511
32	3/8-16 X 5/16 SOCKET SET SCREW CUP POINT P	2	VT37-16SS312
33	1/4" BALL - 302 STAINLESS STEEL	72	V2125
36	CUP SEAL 6.0" ID X 3/16 C/S	1	A1545
37	HALF BALL STAINLESS STEEL	1	A1043S
38	ELBOW 4" (4" STORZ ONLY)	1	A1071
	ELBOW 5"	1	A1054
42	1/2 BARB X 1/4 NPT FITTING	1	XX329
43	DETENT PIN	1	A1560
44	SPRING	1	X345
45	DETENT PIN HOUSING	1	A1570
46	DETENT PIN KNOB	1	A1575
47	SPIROL PIN	1	VP125X750H
48	LOCKING LEVER - MOLDED	1	A4171
49	SPRING TORSION	1	A4230
50	SPOUT 4"NHM X PSF5.25	1	A4620N
	SPOUT 4.5"NHM X PSF5.25	1	A4625N
	SPOUT 5"NHM X PSF5.25	1	A4630N
	COUPLING 4.0"NH X PSF5.25	1	A4660N
	COUPLING 4.5"NH X PSF5.25	1	A4665N
	COUPLING 5.0"NH X PSF5.25	1	A4670N
	COUPLING 6.0"NH X PSF7.0	1	A1266NX
	MATE PSF5.25 X PSM7.0	1	A4745
	PLASTIC STRIP 5.25"	1	A1291
	CUP SEAL 5.25 X 4.750 X 1/4	1	A1296
	LABEL; PORT COVER	1	A1298
	BALL 7/16" STAINLESS	1	VB.437
	COUPLING HEAD STORZ 4" X 4.25PSF	1	A4114
	INSERT RING STORZ 4"	1	A4164
	O-RING 155 4" ID X 3/32 C/S	1	VO-155
COUPLING HEAD STORZ 5" X 5.25PSF	1	A4115	
INSERT RING STORZ 5"	1	A4165	
O-RING 250, 5" ID X 1/8 C/S	1	VO-250	

8.0 DRAWINGS AND PARTS LISTS

Index	Description	QTY	Part #
50	COUPLING HEAD STORZ 6" X 5.25PSF	1	*X696SX-LOCK
	INSERT 6.0"BSPM X PSF5.25	1	A4765
	COUPLING HNDL 4.0"NHF X PSF5.25	1	A4560N
	COUPLING HNDL 4.5"NHF X PSF5.25	1	A4565N
	COUPLING SH 5.0"NHF X PSF7.0 NFS	1	A1261NT
	MATE PSF5.25 X PSM7.0-NFS	1	A4745
	PLASTIC STRIP 5.25"	1	A1291
	CUP SEAL 5.25 X 4.750 X ¼	1	A1296
	LABEL; PORT COVER	1	A1298
	BALL 7/16" STAINLESS	1	VB.437
	COUPLING SH 6.0"NHF X PSF7.0-NFS	1	A1266NX
	MATE PSF5.25 X PSM7.0-NFS	1	A4745
	PLASTIC STRIP 5.25"	1	A1291
	CUP SEAL 5.25 X 4.750 X ¼	1	A1296
LABEL; PORT COVER	1	A1298	
BALL 7/16" STAINLESS	1	VB.437	
51	GASKET 4" PRESSURE (4" STORZ ONLY)	1	A4215
	GASKET 4" PRESSURE (4" STORZ ONLY)/VACUUM	1	A4216
	GASKET 5" PRESSURE (5" STORZ ONLY)	1	A4220
	GASKET 5" PRESSURE (5" STORZ ONLY)/VACUUM	1	A4221
	GASKET 6" PRESSURE (6" STORZ ONLY)/VACUUM	1	A4226
	GASKET 4.0" HOSE COUPLING	1	V3198
	GASKET 4.5" HOSE COUPLING	1	V3210
	GASKET 5.0" HOSE COUPLING	1	V3220
GASKET 6.0" HOSE COUPLING	1	V3240	
52	PLASTIC STRIP 4.25" (4" STORZ ONLY)	1	A1292
	PLASTIC STRIP 5.25"	1	A1291
53	CUP SEAL 4.25X3.750 X 1/4 (4" STORZ ONLY)	1	A1297
	CUP SEAL 5.25 X 4.750 X 1/4	1	A1296
54	BALL 7/16" STAINLESS 302	1	VB.437
56	HOLLOW TRUNNION	1	A1514
57	7/16-14 X 1 HEX HEAD BOLT	4	VT43-14HX1.0
58	LONG BUSHING	1	A1526
59	HANDWHEEL	1	X281
60	NAMEPLATE	1	A1306
61	DRAIN BODY	1	A1543
62	O-RING-115	2	VO-115
63	DRAIN SLEEVE	1	A1541
64	DRAIN LEVER	1	A1542
65	DOG POINT SCREW	1	H515
66	O-RING-110	1	VO-110
67	O-RING-128	1	VO-128
68	O-RING-214	1	VO-214
69	SET SCREW	1	VT31-18SS375

Relief Valve Parts List

Index	Description	QTY	Part #
1	1/2-13 X 1.0 BUTTON HEAD CAP SCREW	1	VT50-13BH1.0
2	O-RING-236 3-1/4 ID 1/8 C/S	1	VO-236
3	DEBRIS WASHER	1	A1169
4	HOUSING W/OUT THDS	1	A1150
5	5/16-18 X 3/8 SOCKET SET SCREW CUP POINT	1	VT31-18SS375
6	VALVE SEAT	1	A1168
7	PISTON -HARDCOAT	1	A1160
8	O-RING-231 2-5/8 ID 1/8 C/S	1	VO-231
9	QUAD RING 422 1.5 ID X 1/8 C/S	2	VOQ-4222
11	SPRING SEAT	1	A1166
12	RELIEF SPRING	1	A1170
13	SMALLEY RING	1	V4210
14	ADJUSTING SCREW	1	A1167
15	SPRING HOUSING	1	A1164

9.0 MAINTENANCE

This valve should be disconnected, cleaned and visually inspected inside and out at least once per month. Moving parts such as hand wheels, valve ball/seat and couplings should be checked for smooth and free operation and greased as needed. A silicone based grease such as Dow Corning 112 will exclude moisture and retard the effects of corrosion. Any scrapes that expose bare aluminum should be cleaned and touched up with enamel paint such as Rust-Oleum. Replace any missing or damaged parts before returning valve to service.

CAUTION

Dissimilar metals coupled together can cause galvanic corrosion that can result in the inability to unscrew the threads of complete loss of thread engagement over time. Per NFPA 1962 (1998 edition), if dissimilar metals are left coupled together an anti-corrosive lubricant should be applied to the threads. Also the coupling should be disconnected and inspected at least quarterly.

CAUTION

Any alterations to the Ball Intake Valve and its markings could diminish safety and constitutes a misuse of this product.

10.0 BALL INTAKE VALVE PRESSURE LOSS

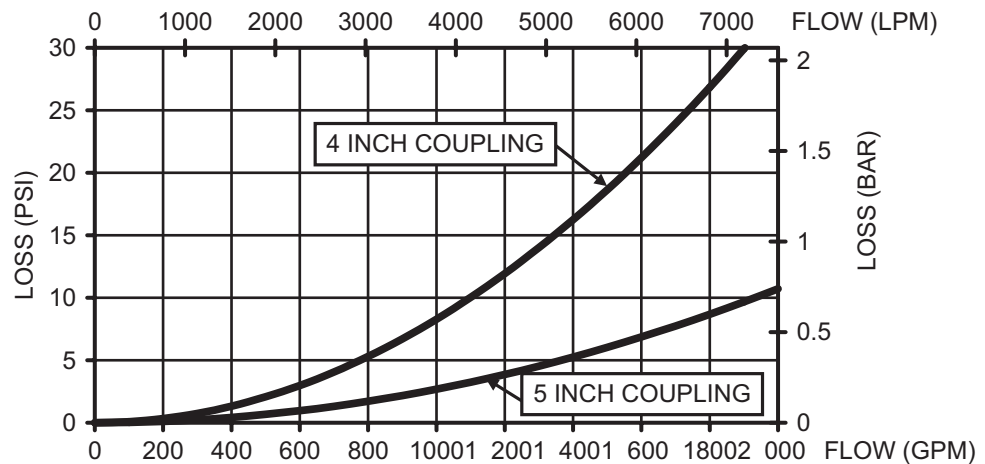

11.0 WARRANTY

Task Force Tips, Inc., 2800 East Evans Avenue, Valparaiso, Indiana 46383 ("TFT") warrants to the original purchaser of its Ball Intake Valve ("equipment"), and to anyone to whom it is transferred, that the equipment shall be free from defects in material and workmanship during the five (5) year period from the date of purchase.

TFT's obligation under this warranty is specifically limited to replacing or repairing the equipment (or its parts) which are shown by TFT's examination to be in a defective condition attributable to TFT. To qualify for this limited warranty, the claimant must return the equipment to TFT, at 2800 East Evans Avenue, Valparaiso, Indiana 46383, within a reasonable time after discovery of the defect. TFT will examine the equipment. If TFT determines that there is a defect attributable to it, TFT will correct the problem within a reasonable time. If the equipment is covered by this limited warranty, TFT will assume the expenses of repair.

If any defect attributable to TFT under this limited warranty cannot be reasonably cured by repair or replacement, TFT may elect to refund the purchase price of the equipment, less reasonable depreciation, in complete discharge of its obligations under this limited warranty. If TFT makes this election, claimant shall return the equipment to TFT free and clear of any liens and encumbrances.

This is a limited warranty. The original purchaser of the equipment, any person to whom it is transferred, and any person who is an intended or unintended beneficiary of the equipment, shall not be entitled to recover from TFT any consequential or incidental damages for injury to person and/or property resulting from any defective equipment manufactured or assembled by TFT. It is agreed and understood that the price stated for the equipment is in part consideration for limiting TFT's liability. Some states do not allow the exclusion or limitation of incidental or consequential damages, so the above may not apply to you.

TFT shall have no obligation under this limited warranty if the equipment is, or has been, misused or neglected (including failure to provide reasonable maintenance) or if there have been accidents to the equipment or if it has been repaired or altered by someone else.

THIS IS A LIMITED EXPRESS WARRANTY ONLY. TFT EXPRESSLY DISCLAIMS WITH RESPECT TO THE EQUIPMENT ALL IMPLIED WARRANTIES OF MERCHANTABILITY AND ALL IMPLIED WARRANTIES OF FITNESS FOR A PARTICULAR PURPOSE. THERE IS NO WARRANTY OF ANY NATURE MADE BY TFT BEYOND THAT STATED IN THIS DOCUMENT.

This limited warranty gives you specific legal rights, and you may also have other rights which vary from state to state.

TASK FORCE TIPS, Inc.
MADE IN USA • www.tft.com

2800 E. Evans Ave, Valparaiso, IN 46383-6940 USA
800-348-2686 • 219-462-6161 • Fax 219-464-7155