



MID-MATIC, Mid-Force & METRO 1 Maintenance and Service Procedure

INTRODUCTION

TASK FORCE TIP MID-MATIC, MID-FORCE and METRO 1: The nozzle you have purchased is one of your primary tools in saving life and property. It has been manufactured with great care to give you the finest performance possible. All components are of top quality and extremely rugged. With regular inspection and maintenance it will serve you for many years. This publication is intended for those who prefer to perform service on their own equipment. Factory service is available, and repair time seldom exceeds one day in our facility. Factory serviced nozzles are repaired by experienced workmen, fully tested and promptly returned functioning to original specifications. Task Force Tips assumes no liability for damage to equipment or injury to personnel that is a result of user service.

GENERAL INFORMATION

TOOLS REQUIRED

The following tools are required for general service to the nozzle:

- 3/32, 1/8, 3/16, 7/32 and 5/16 Allen Wrenches
- 9/16 box or open end wrench
- Dow #112 high temperature silicone grease
- Loctite #271 thread locker or equivalent
- oxyacetylene torch
- razor knife

Additional tools needed to service the shaper are:

- strap wrench
- vise with padded jaws
- Mid-Matic shaper removal clamp
- Mid-Force shaper removal clamp
(special tool TFT #THM-500)

Additional tools needed to service the pressure control are:

- dental pick
- two small probes, approximately 1/16 dia
(such as a drill bit)

THREADED JOINTS: Threaded joints have been secured using Loctite brand thread locking adhesive #271. Disassembly of joints where #271 Loctite was used requires a minimal application of heat with a oxyacetylene torch to break the bond. The threads should be heated to approximately 450 degrees F. Excessive heat application will cause damage to adjacent seals and labels. Replacement parts must be reinstalled using Loctite #271 or equivalent. Threads must be clean, dry, and free of grease or oil when applying Loctite. Allow Loctite to set up for at least one hour before using or subjecting to water. Small vials of Loctite for field service are available; order part # V5010 (#271 LOCTITE MINI DISPENSER).

LUBRICANTS: If parts are disassembled in an area where o-rings are present, re-assemble using DOW #112 High Temperature Silicone Grease on all o-rings and surfaces that the o-rings contact. If nozzle is not disassembled refer to field lubrication procedure. (on back)

LABEL REPLACEMENT: If labels become damaged, remove old labels with razor knife. Remove adhesive with acetone or methyl ethyl ketone. Surface must be clean, dry, and free from grease. Remove protective backing and carefully apply new label.

ORDERING PARTS: Always specify the serial number of the nozzle when ordering parts. The serial number is found on the back of the nozzle next to the coupling. Be sure to use complete DESCRIPTION and ORDER #, as printed on parts list. All requests for couplings must specify thread size. Pricing information will be given at time of order. Parts and Repair Kits may be purchased on-line at www.tft.com

COUPLING SERVICE PROCEDURE

GENERAL: Occasional replacement of hose gaskets is recommended. Replace GASKET GRABBER (8) if severe impact from debris has caused damage. Coupling service kits which include all hardware and Loctite are available. Couplings with special or standard threads are available and may be exchanged on new nozzles. Please specify desired threads when ordering.

COUPLING REMOVAL: All couplings are retained with a ball race and set screw. Heat and remove the SOCKET SET SCREW (6 or 7) from coupling using an 1/8" Allen wrench. Turn coupling so that hole faces down, and rotate coupling back and forth to allow the 3/16 STAINLESS STEEL BALLS (5) to drop out. When all balls are out of the groove, the coupling can be removed.

V OR VPGI COUPLING INSTALLATION: Inspect and if necessary replace the 134 O-RING (9). Grease and install the o-ring onto the VALVE BODY (10). Insert the GASKET GRABBER (8) debris screen onto the valve body with the raised end pointing toward the front of the nozzle. Put the coupling onto the valve body and load 34 BALLS (5) into the ball groove. Insertion of the balls is easier if the coupling is rotated slightly back and forth as the balls are loaded. Use Loctite #271 and install the SOCKET SET SCREW (6). The set screw should be flush with the surface of the coupling. If the coupling is difficult to turn, or feels rough when turned, the set screw is in too far. Back set screw off and try again. If the feel is still not correct, recheck the number of balls in the coupling.

TIP ONLY COUPLING INSTALLATION: The coupling installation procedure for Tip Only models is the same as the above procedure except that only 33 balls and a longer SET SCREW (7) are used. Run the set screw into the small slot on the male ball groove of the TAIL PIECE or BASE (26 or 40) until it bottoms out without applying pressure. This locks the coupling on Tip Only models from rotation.

SEPARATING FRONT END FROM BACK: On models with valves, heat the two SET SCREWS (19) and remove with a 3/32 Allen wrench. Then unscrew the front end from the valve assembly. To reassemble see section on VALVE SHUTOFF ADJUSTMENT.

On Tip Only models (no valve) the TIP ONLY BASE (40) is retained on the nozzle front end by threads which are retained by Loctite #271. Apply heat at the knurled rib nearest the front of the nozzle. Damage to seals and labels can be reduced by protecting these with a wet rag. The TIP ONLY BASE (40) can now be unscrewed. Remove and replace 139 O-RING (46). To reassemble, clean all threads, apply Loctite and screw together.

BOLT ON PISTOL GRIP SERVICE: PISTOL GRIP (80) is held on by a SCREW (83). Remove screw and WASHER (82) with a 5/16 Allen wrench. To reinstall, clean thread and apply Loctite #271. Tighten screw to 20 FT-LBS.

VALVE SERVICE PROCEDURE

VALVE PLUG REPLACEMENT: After removing back end (see section on Separating Front End From Back), VALVE PLUG (23, 39, or 41) is removed by pulling straight back. New valve plug is installed by pushing in with slight finger pressure.

V OR VPGI VALVE DISASSEMBLY SEQUENCE

HANDLE REMOVAL: Heat and then remove both BUTTON HEAD CAP SCREWS (14) from VALVE HANDLE (11) using a 7/32 Allen wrench. Slide CAM and SAFETY PINS (15 and 16) out of handle by gently hitting nozzle against work surface. To remove handle, pull upwards while containing the DETENT BALLS (13) and SPRINGS (12) to prevent their loss. Service to interior valve parts should be done prior to reinstalling handle.

TASK FORCE TIPS, Inc.

2800 East Evans Avenue • Valparaiso, IN 46383-6940
800-348-2686 • 219-462-6161 • Fax 219-464-7155

SLIDER AND SEAL REMOVAL: Referring to appropriate sections remove the handle and front end from valve assembly. With handle and front end removed the SLIDER (22) can be pulled out from front of valve. Remove and inspect O-RINGS (20, 21 and 46). Replace o-rings if they are damaged.

VOR VPGI VALVE ASSEMBLY SEQUENCE

SLIDER AND SEAL INSTALLATION: Insert O-RINGS (20, 21 and 46) into the proper grooves in the valve body. Check SLIDER (22) for any raised metal at groove area. Replace if necessary. Lubricate o-rings and slider with silicone grease. Push slider into the valve body.

HANDLE INSTALLATION: Insert DETENT SPRINGS (12) and DETENT BALLS (13) into the handle lugs. While holding balls in place snap the HANDLE (11) onto valve body with offset holes FORWARD. Carefully align the groove on SLIDER (22) with offset hole in valve discs and offset hole in handle. Start SAFETY PIN (16) into offset hole in handle. Push down into engagement with groove in slider, until head of pin is flush with handle. Repeat procedure for CAM PIN (15). Apply Loctite #271 to both BUTTON HEAD SCREWS (14) and insert through lower handle holes. Thread each into corresponding center disk hole. Tighten button head screw securely. Cycle handle and check that it snaps firmly and smoothly into all detent positions and that slider moves back and forth.

VALVE SHUTOFF ADJUSTMENT: Shutoff valve is adjusted by the threads between the valve body and the front portion of the nozzle. While holding the VALVE HANDLE (11) against stops in the OFF position, screw front end into the valve body until contact is made with the valve plug. Open handle up to remove contact. Screw the front end in 1/12 turn further to give the valve shutoff compression. Apply Loctite to SET SCREWS (19). Thread in both set screws until they bottom out, without applying pressure. In an alternating fashion continue turning in set screws until tight.

VALVE ADJUSTMENT FOR SEVERE COLD: To help prevent hose line freezing in cold climates, the valve may be adjusted for intentional leakage by unscrewing front end slightly. The valve can be returned to normal adjustment for complete shut off during warm weather by following the procedure in the last section.

TWIST TYPE VALVE SERVICE PROCEDURE

STO SLEEVE SERVICE: To remove the STO SLEEVE (36), first heat and remove the CAM SCREWS (38) and DETENT SCREWS (37). The detent screws contain SPRINGS (34) and BALLS (35). STO SLEEVE (36) is then removed by sliding forward. Inspect O-RINGS (30) and replace if damaged. Installation is reverse of removal. Before reassembly grease o-rings. Clean screw threads and apply Loctite #271.

STO VALVE SERVICE: Heat the back end of the STO BASE (33) with a torch and unscrew the STO TAIL PIECE (26). The STO SLIDER (29) may now be removed. Inspect and replace any damaged O-RINGS (27, 28 and 46). Grease o-rings, clean threads and use Loctite #271 upon reassembly.

SHAPER SERVICE PROCEDURE

SHAPER REMOVAL: The rubber bumper is permanently bonded onto the stream shaper as a single unit the SHAPER (63). The shaper is attached to the SHAPER GUIDE (47 OR 50) by a threaded joint that is retained by Loctite #271. Grip rear portion of the nozzle in a vise with padded jaws. Or clamp SHAPER GUIDE (47 or 50) using TFT special tool THM-500 (for MID-MATIC) or THMD-500 (for MID-FORCE) held in a vise. Direct a hot narrow flame around the rear portion of the shaper. Heat for approximately 20 seconds, being careful not to damage the bumper or labels (a wet rag wrapped around these areas will help). Use a strap wrench to unscrew the shaper from the shaper guide. Remove the shaper. Inside the shaper are 64, 1/8 NYLON BALLS (61), some of which may fall free as it is removed. If shaper is to be re-used, clean ball track and replace O-RING-230 (62) if damaged.

SHAPER INSTALLATION: Install O-RING-230 (62) in front groove of SHAPER (63). Grease the seal and ball groove heavily. Place 64, 1/8 NYLON BALLS (61) into greased ball groove. Apply Loctite #271 to male thread on SHAPER GUIDE (47 or 50). Start shaper onto SHAPER GUIDE threads. Place three SHAPER GUIDE BALLS (52) into the grooves on barrel and screw down shaper until threads bottom out.

PRESSURE CONTROL REMOVAL: To remove the CONTROL UNIT first separate the front end from the nozzle, then remove the VALVE PLUG (23, 39 or 41). Loosen and remove the shaft locking SCREW (64) with a 3/16 allen wrench. Insert a 7/32 Allen wrench into the front of the shaft and screw the shaft out of the barrel assembly. LOCKING SLEEVE (65) is removed by pushing it forward and out of BARREL ASSEMBLY (53 or 54) with a punch. *Note: LOCKING SLEEVE may require light tapping with a hammer to remove.*

PRESSURE CONTROL INSTALLATION AND INITIAL OPENING ADJUSTMENT: To install the CONTROL UNIT, lightly grease I.D. and O.D. of locking sleeve and also threads of the screw. Place LOCKING SLEEVE (65) with hollow end forward onto back of shaft, thread finger tight. *Note: If old LOCKING SLEEVE is reused it may require light tapping with a hammer and punch to install.* Screw CONTROL UNIT (with pressure control parts installed) into barrel assembly. Insert a 7/32 Allen wrench into front of shaft and turn in until baffle just touches BARREL CONE (60) then turn back 3/8 turn for 100 PSI nozzles or 3/4 turn for 75 PSI nozzles. Keep Allen wrench in shaft to assure that shaft doesn't turn and tighten screw against locking sleeve, to approximately 175 in-lbs. **IMPORTANT: Always flow test after adjusting.**

Nozzle pressure and flow requirements are shown on the following table:

	NOZZLE PRESSURE AT 70 GPM	NOZZLE PRESSURE AT 200 GPM
100 PSI MODEL		90/115 psi
75 PSI MODEL		75/85 psi

PROBLEMS:

If you have any questions or problems, please call for assistance.

(800) 348-2686 • (219) 462-6161 • FAX (219) 464-0620

TASK FORCE TIPS INC. - www.tft.com

2800 East Evans Avenue • Valparaiso, IN 46383-6940

www.tft.com

BACK END PARTS

COUPLINGS

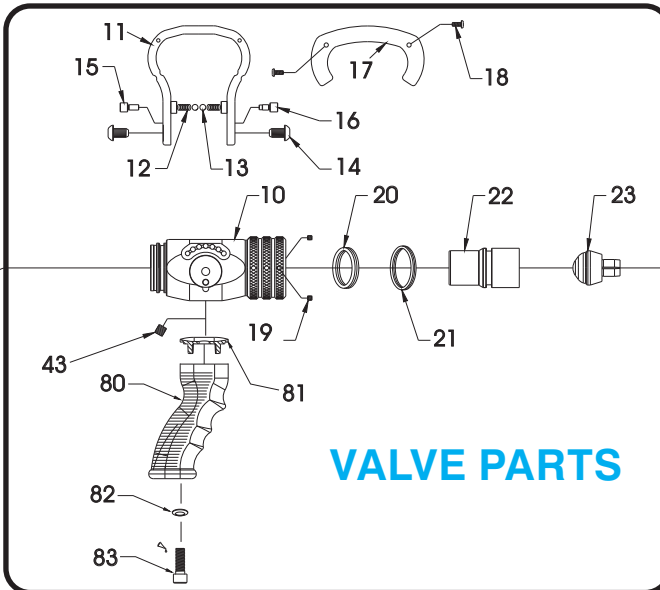
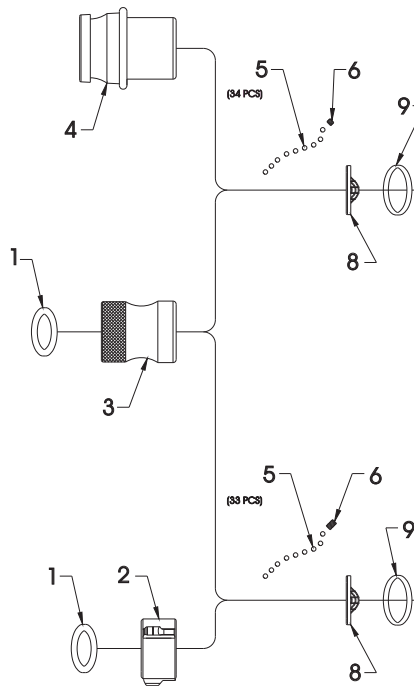

VALVE PARTS

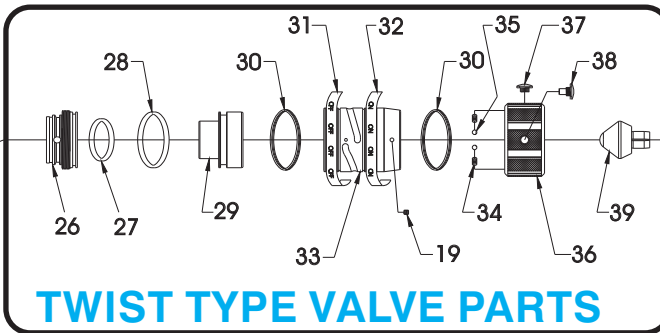

TWIST TYPE VALVE PARTS

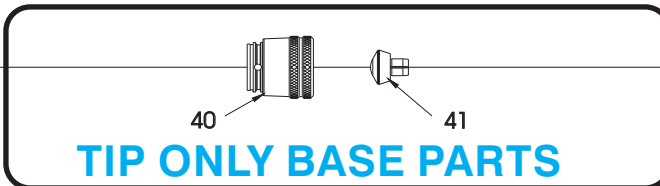

TIP ONLY BASE PARTS

DESCRIPTION	QTY	ORDER #	DESCRIPTION	QTY	ORDER #
1 1.5" COUPLING GASKET	1	V3130	26 S.T.O. TAIL PIECE	1	HM662
2 1.5" ROCKER LUG COUPLING	1	HM697*	27 O-RING 129	1	VO-129
3 1.5" BSP STRETCH COUPLING	1	HM685B	28 O-RING 138	1	VO-138
4 2.5" BIC COUPLING	1	HM687	29 S.T.O. SLIDER	1	HM661
5 3/16 SS BALLS	33/34	V2120	30 QUADX-4037	2	VOQ-4037
6 1/4-28 X 3/16 SOCKET SET SCREW	1	VT25-28SS187	31 "OFF" LABEL	1	HD755
8 GASKET GRABBER	1	HM730	32 "ON" LABEL	1	HD750
9 O-RING 134	1	VO-134	33 S.T.O. BASE	1	HM655
10 VALVE BODY	1	HM600	34 DETENT SPRING	2	VM4200
VALVE DISK	2	HM640	35 3/16" TORLON BALLS	2	V2120-TORLON
DRAG NUB	4	HM650	36 S.T.O. SLEEVE	1	HM668
SMALLEY RING	2	V4270	37 DETENT SCREW	2	HD785
11 VALVE HANDLE	1	HM620	38 CAM SCREW	2	HD780
12 DETENT SPRING	2	HM770	39 S.T.O. VALVE PLUG	1	HM592
13 DETENT BALL	2	VB243TO	40 T.O. BASE	1	HM670
14 HANDLE SCREW	2	HM645	41 T.O. VALVE PLUG	1	HM591
15 CAM PIN	1	HM630	43 3/8-24 X 3/8 SOCKET SET SCREW	1	VT37-24SS375
16 SAFETY PIN	1	HM635	46 O-RING 139	1	VO-139
17 VALVE HANDLE COVER	2	HM625-BLK	50 MID-FORCE SHAPER GUIDE	1	HMD510
18 8-32 X 3/8 BH CAP SCREW	4	HM626	51 NAME LABEL - 100 PSI	1	HM745
19 10-32 X 3/16 SOCKET SET SCREW	2	VT10Y32SS187	NAME LABEL - 75 PSI	1	HM745L
20 QUADX-4221	1	VOQ-4221	MID-FORCE NAME LABEL	1	HMD745
21 QUADX-4130	1	VOQ-4130	METRO 1 NAME LABEL	1	HM745-ORG
22 SLIDER	1	HM660	52 TORLON GUIDE BALLS	3	VB243TO
23 VALVE PLUG	1	HM590			

FRONT END PARTS

SPRAY ADJUSTMENT PARTS

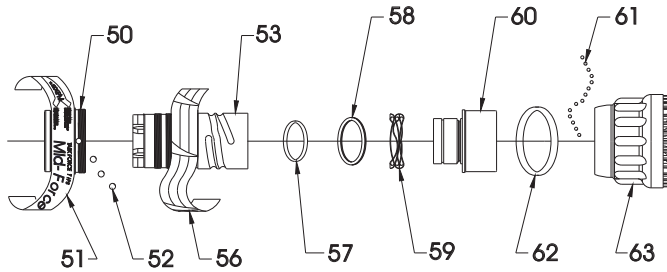

DESCRIPTION	QTY	ORDER #
53 FIN CAN/BARREL	1	HM545
56 BARREL LABEL	1	HM740
MID-FORCE BARREL LABEL	1	HMD740
METRO 1 BARREL LABEL	1	HM740-ORG
57 O-RING-030	1	VO-030
58 WS-175-S02 SMALLEY RING	1	VR4230
59 FLUSH WAVE SPRING	1	HM785
60 BARREL CONE	1	HM520
61 1/8 NYLON BALL	64	V2135
62 O-RING-230	1	VO-230
63 SHAPER WITH BUMPER	1	HM500
64 LOCKING SCREW	1	VT25-28SH750
65 LOCKING SLEEVE	1	HM571
66 SHAFT	1	HM470
67 O-RING-011	1	VO-011

PRESSURE CONTROL PARTS

100 PSI CONTROL UNIT - HM840-KIT
or
75 PSI CONTROL UNIT - HM840-75-KIT

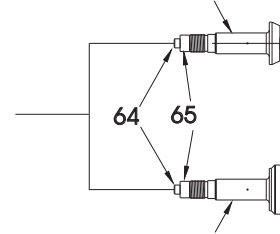

100/55 DUAL PRESSURE CONTROL UNIT - HMD840-KIT
or
75/45 DUAL PRESSURE CONTROL UNIT - HMD840-75KIT

METRO 1 PRESSURE CONTROL UNIT

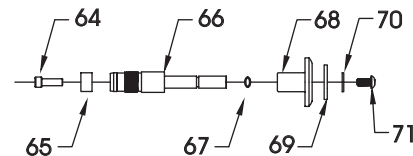

DESCRIPTION	QTY	ORDER #
68 BAFFLE	1	HM461
69 FLOW WASHER K=12.5 OR 9.5	1	HM410-14
FLOW WASHER K=15.0 OR 14.4	1	HM410-15
FLOW WASHER K=17.5 OR 17.3	1	HM410-17
FLOW WASHER K=20.0 OR 20.2	1	HM410-21
FLOW WASHER K=23.1 OR 21.2	1	HM410-23
80 PISTOL GRIP	1	HM692-BLK
81 SPACER	1	HM693-HM
82 WASHER	1	VM4901
83 3/8-16 X 1 SOCKET HEAD CAP SCREW	1	VT37-16SH1.0
84 5/16-18 X 1/4 SOCKET SET SCREW	1	VT31-18SS250

REPAIR KITS

STANDARD CONTROL UNIT	HM840-KIT
MID-FORCE CONTROL UNIT	HMD840-KIT
75 PSI CONTROL UNIT	HM840-75-KIT
STANDARD SHUT-OFF	HM590-KIT
TIP-ONLY WITH SHUT-OFF	HM592-KIT
COUPLING - NST REPAIR KIT	HM997N-KIT
COUPLING - IPT REPAIR KIT	HM997I-KIT
RED PISTOL GRIP KIT	HM692RED-KIT
GREEN PISTOL GRIP KIT	HM692GRN-KIT
BLUE PISTOL GRIP KIT	HM692BLU-KIT
BLACK PISTOL GRIP KIT	HM692BLK-KIT
ORANGE PISTOL GRIP KIT	HM692ORG-KIT

WHITE PISTOL GRIP KIT	HM692WHT-KIT
YELLOW PISTOL GRIP KIT	HM692YEL-KIT
RED HANDLE COVER KIT	HM925RED-KIT
GREEN HANDLE COVER KIT	HM925GRN-KIT
BLUE HANDLE COVER KIT	HM925BLU-KIT
BLACK HANDLE COVER KIT	HM925BLK-KIT
ORANGE HANDLE COVER KIT	HM925ORG-KIT
WHITE HANDLE COVER KIT	HM925WHT-KIT
YELLOW HANDLE COVER KIT	HM925YEL-KIT

SPECIAL TOOLS

MID-MATIC SHAPER REMOVALCLAMP	THM-500
SHAFT REMOVAL TOOL	THM-570
SMALLEY RING REMOVAL TOOL	THM-561

TASK FORCE TIPS, Inc.

2800 East Evans Avenue • Valparaiso, IN 46383-6940
800-348-2686 • 219-462-6161 • Fax 219-464-7155