

AUTOMATIC PRESSURE CONTROL  
ADJUSTABLE PRESSURE

**TASK FORCE TIPS, INC.**  
2800 E. EVANS AVE.  
VALPARAISO, IN 46383  
219-462-6161



REV	DATE	INITIALS
5	8/4/05	ACY
6	1/9/08	CPD
7	12/10/09	CPD

SCALE: 1/4 X

PRINT DRAWN  
12/21/04 MBJ

PRINT APPROVED  
12/16/09 TJB

DESIGN ENGINEER  
*Alex Youanovich*

DIMENSIONS IN 'INCHES' UNLESS SPECIFIED OTHERWISE  
FILE: M\FIN & SUB\MASTER 2000\

PART NUMBER: M-ER2000-NN

DESCRIPTION: MASTER STREAM 2000 ELECTRIC 3.5"

EXTRA DESC: 300-2000 GPM @ 80-120 PSI 12-24 VDC ACTUATOR

SHEET  
1 OF 3

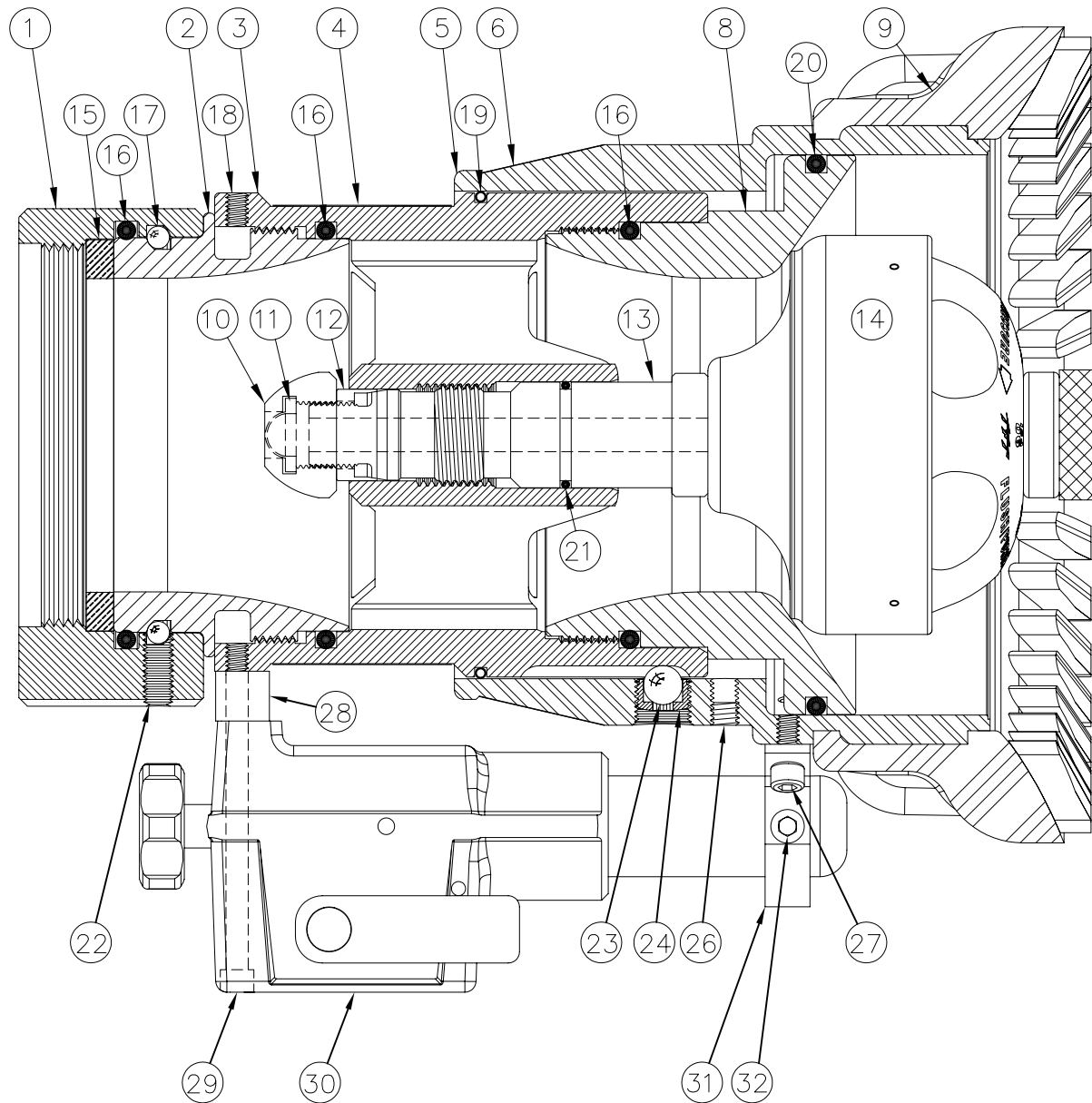

**TASK FORCE TIPS, INC.**  
 2800 E. EVANS AVE.  
 VALPARAISO, IN 46383  
 219-462-6161



REV	DATE	INITIALS
5	8/4/05	ACY
6	1/9/08	CPD
7	12/10/09	CPD

SCALE: HALF		
PRINT DRAWN	8/4/05	ACY
PRINT APPROVED	12/16/09	JLH
DESIGN ENGINEER		Alex Youanovich

DIMENSIONS IN 'INCHES' UNLESS SPECIFIED OTHERWISE  
 FILE: M\FIN&SUB\MASTER 2000\

PART NUMBER: M-ER2000-NN

SHEET  
2 OF 3

DESCRIPTION: MASTER STREAM 2000 ELECTRIC REMOTE 3.5"

EXTRA DESC: 300-2000 GPM @ 100 PSI 12-24 VDC ACTUATOR

**MASTER STREAM 2000 ELECTRIC REMOTE NOZZLE  
MODELS: M-ER2000-\* AND M-ERP2000-\***  
**PARTS LISTING - SHEET 3 OF 3**

Ref. #	Part Number	Qty.	Description
1*	MS687N	1	3.5" NH COUPLING ROCKERLUG
2	MS230	1	BASE RING
3	MS244	1	FIN CAN/BARREL LINEAR
4	MS740	1	BARREL LABEL: MASTER STREAM 2000
5	MS200	1	SHAPER
6	MS747	1	NAME LABEL: MASTER STREAM 2000
8	MS220	1	BARREL CONE
9	MS205	1	BUMPER
10	MS272	1	REAR NUT
11	MS730	1	FILTER WASHER
12	MS271	1	LOCKING SLEEVE
13	MS270	1	SHAFT
14	MS820	1	PRESSURE CONTROL UNIT SUBASSEMBLY
15*	V3196	1	3.5" HOSE COUPLING GASKET
16	VO-348	3	O-RING-348 4-3/8 ID 3/16 C/S
17	V2125	54	1/4" BALL - 302 STAINLESS STEEL
18	VT25-20SS312	1	1/4-20 X 5/16 SOCKET SET SCREW
19	MS510	1	WEAR STRIP
20	VO-360	1	O-RING-360 5-7/8 ID 3/16 C/S
21	VO-120	1	O-RING-120 1 ID 3/32 C/S
22	VT31-24SS625	1	5/16-24 X 5/8 SOCKET SET SCREW
23	VB437TO	1	BALL 7/16" TORLON
24	FT260	1	CUP
25	VM1080	2	.375 X 1/2 BLACK VINYL CAP
26	VT31-18SS375	3	5/16-18 X 3/8 SOCKET SET SCREW
27	VT25-20SH750	2	1/4-20 X 3/4 SOCKET HEAD CAP SCREW
28	MS058	1	MOTOR SPACER
29	VT25-20SH3.5	2	1/4-20 X 3-1/2 SOCKET HEAD CAP SCREW
30	MS935 (for MS-ER-*)	1	12-24VDC CAST ACTUATOR ASSEMBLY
	MS945 (for MS-ERP-*)	1	12-24VDC ACTUATOR W/PLUG ASSEMBLY
31	MS580	1	YOKE
32	H515	2	3/8-24 X 3/8 DOG POINT

\*NOTE: VARIOUS COUPLINGS AVAILABLE, SPECIFY SIZE AND THREAD DESIRED.

CIMNET\_DATA\MM-ER2000-NNMS-ER.DOC 6-15-95 DMH  
REVISION #: 7 12/10/09 CPD  
APPROVED: 12/16/09 TLH  
TO BE USED WITH: SHEET 2 OF 3 CROSS SECTION M-ER2000-NN