



PRO/pak Portable Multi-Purpose Foam System

MANUAL FOR SAFE OPERATION AND MAINTENANCE

⚠ DANGER

Lack of foam can place operator at risk of injury or death. Establish foam flow before advancing into hazardous situations. Make sure you do not run out of foam concentrate before the task is complete. Check concentrate level periodically and keep an adequate supply on hand.

⚠ WARNING

Read instruction manual before use. Operation of this device without understanding the manual and receiving proper training is a misuse of this equipment. Users who have not read and understood all operating and safety instructions are not qualified to operate this portable foam system. This instruction manual is intended to familiarize firefighters and maintenance personnel with the operation, servicing, and safety procedures associated with the PRO/pak Portable Foam System. This manual should be kept available to all operating and maintenance personnel.

⚠ WARNING

Improper use of foam can result in injury or damage to the environment. Follow the foam concentrate manufacturer's instructions and fire service training to avoid the following: Using the wrong type of foam on a fire, i.e. Class A foam on Class B flammable liquid fire; Mishandling of concentrates; Plunging foam into pools of liquid fuels; Directing foam onto yourself or other personnel.

⚠ WARNING

There is a wide variety of foam concentrates. Each user is responsible for verifying that any foam concentrate chosen to be used with this unit has been tested to assure that the foam obtained is suitable for the purpose intended.

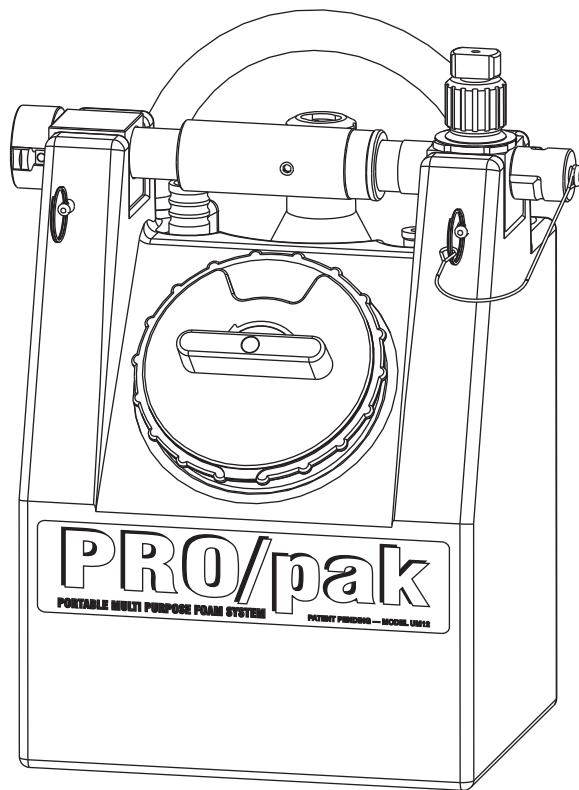

RATED FLOW
12 GPM at 100 PSI
45 L/MIN at 6.8 BAR

Minimum Operating Condition
7 GPM at 40 PSI
30 L/MIN at 3 BAR
Maximum Operating Condition
27 GPM at 500 PSI
100 L/MIN at 40 BAR

TASK FORCE TIPS, Inc.
MADE IN USA • www.tft.com

2351 Industrial Drive, Valparaiso, IN 46383-9511 USA
800-348-2686 • 219-462-6161 • Fax 219-464-7155

TABLE OF CONTENTS

- 1.0 MEANING OF SIGNAL WORDS
- 2.0 SAFETY
- 3.0 GENERAL INFORMATION
 - 3.1 PART IDENTIFICATION
 - 3.2 LEFT or RIGHT HAND OPERATION
- 4.0 FOAM SELECTION
 - 4.1 CLASS A FOAM
 - 4.2 CLASS B FOAM
 - 4.3 FOAM COMPATIBILITY
- 5.0 NOZZLE SELECTION
- 6.0 OPERATION
 - 6.1 HOSE CONNECTION
 - 6.2 FILLING TANK
 - 6.3 CONNECT HOSE AND NOZZLE
 - 6.4 SETTING FOAM CONCENTRATION
 - 6.5 CONTROLLING FLOW
 - 6.6 FOAM QUALITY
 - 6.7 SHUT DOWN AFTER USE (FLUSHING)
 - 6.8 STORAGE
- 7.0 TROUBLE-SHOOTING
- 8.0 CLEAN UP AND MAINTENANCE
 - 8.1 DRAIN INSTALLATION
- 9.0 SPECIFICATIONS
- 10.0 DRAWINGS AND PARTS LIST
- 11.0 WARRANTY

⚠ DANGER

PERSONAL RESPONSIBILITY CODE

The member companies of FEMSA that provide emergency response equipment and services want responders to know and understand the following:

1. Firefighting and Emergency Response are inherently dangerous activities requiring proper training in their hazards and the use of extreme caution at all times.
2. It is your responsibility to read and understand any user's instructions, including purpose and limitations, provided with any piece of equipment you may be called upon to use.
3. It is your responsibility to know that you have been properly trained in Firefighting and /or Emergency Response and in the use, precautions, and care of any equipment you may be called upon to use.
4. It is your responsibility to be in proper physical condition and to maintain the personal skill level required to operate any equipment you may be called upon to use.
5. It is your responsibility to know that your equipment is in operable condition and has been maintained in accordance with the manufacturer's instructions.
6. Failure to follow these guidelines may result in death, burns or other severe injury.



Fire and Emergency Manufacturers and Services Association, Inc.
P.O. Box 147, Lynnfield, MA 01940 • www.FEMSA.org

1.0 MEANING OF SIGNAL WORDS

A safety related message is identified by a safety alert symbol and a signal word to indicate the level of risk involved with a particular hazard. Per ANSI standard Z535.4-1998 the definitions of the three signal words are as follows:

⚠ DANGER

DANGER indicates an imminently hazardous situation which, if not avoided, will result in death or serious injury.

⚠ WARNING

WARNING indicates a potentially hazardous situation which, if not avoided, could result in death or serious injury.

⚠ CAUTION

CAUTION indicates a potentially hazardous situation which, if not avoided, may result in minor or moderate injury.

2.0 SAFETY

This portable foam system can be used in potentially dangerous situations. The following must be observed at all times:

⚠ WARNING

Make sure that the foam concentrate in the foam tank is the right type for the situation. Do not use Class A foam on Class B fires or Class B foam on Class A fires. Note: Some foam concentrates are universal and can be used on Class B fires and spills and as a wetting agent on Class A fires. (Refer to foam concentrate manufacturer's recommendations for proper foam choice.)

⚠ WARNING

Foam concentrates can be ineffective if not used at the correct percentage. Make sure that the Percentage Knob is set to the correct concentration for the type of foam being used.

⚠ CAUTION

Make sure the Flow Control Valve is off and the correct nozzle and Outlet Hose are securely attached to the Control Block before the hose line is charged.

3.0 GENERAL INFORMATION

The PRO/pak Portable Foam System is a very versatile eductor-type foam application appliance. It can be used with 0.1%-1% Class A foam concentrates for wildland, rural and urban fire suppression on Class A fuels (wood, paper, combustible materials). On Class A materials the PRO/pak is intended to be used for direct extinguishment, overhaul, and wetting of fuels. Some foam concentrates are corrosive, we recommend using only Class A concentrates that have received USDA and USFS approval.

On Class B materials the PRO/pak is primarily intended to be used for vapor suppression. It can be used with 1% and 3% AFFF Class B concentrates on flammable liquids that do not contain alcohol. It can be used with 3% and 6% Alcohol Resistant AFFF Class B concentrates on flammable liquids containing polar solvents. It can also be used with 3% X 6% or 6% Class B foam concentrates. When ever possible back up the PRO/pak with additional water/foam capabilities for added safety.

The The Pro/pak can be used on ignited liquid fuels, but it's foam application rate is very limited. Based on NFPA 11 this unit should not be used on ignited Class B fuels with an area greater than 120 square feet (10 x 12 feet) or 11 square meters. The PRO/pak should not be used on burning Polar Solvents with an area greater than 60 square feet (6 x 10 feet) or 5.5 square meters.

The PRO/pak is designed for Class A and Class B foam concentrates, but it has been used with other concentrates for other uses.

If you intend to use the PRO/pak for liquids other than Class A and Class B concentrates and water, we urge you to contact the Task Force Tips Engineering Department. The use of other liquids may void the warranty and subject the user to hazzards not addressed in this manual. The user assumes all risks for non intended uses.

PRO/pak FLOW CHARACTERISTICS (with valve fully open)

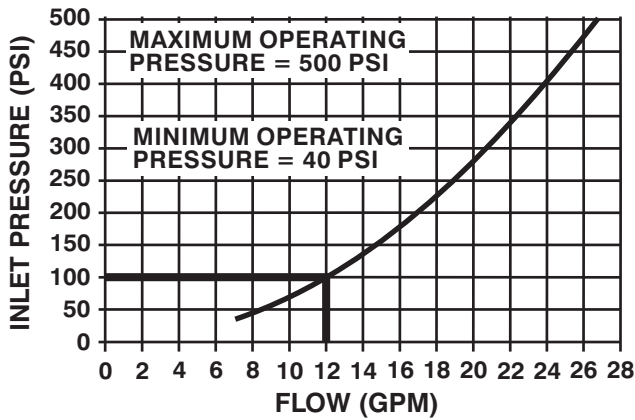

MINUTES TO USE 2½ GALLONS OF CONCENTRATE AT 12 GPM	
PERCENT	MINUTES
0.1	208
0.2	104
0.3	69
0.4	52
0.5	42
1	21
3	7
6	3.5

PRO/pak FLOW CHARACTERISTICS (with valve fully open)

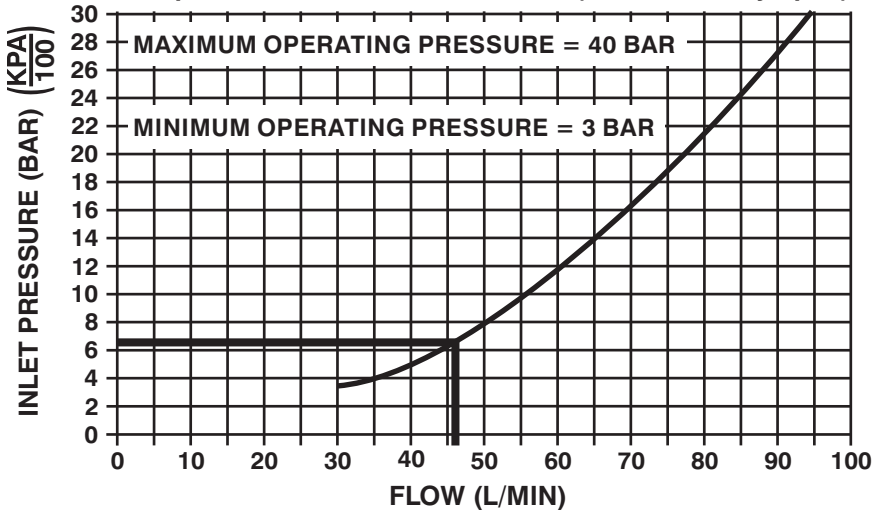

MINUTES TO USE 10 LITERS OF CONCENTRATE AT 45 l/min	
PERCENT	MINUTES
0.1	208
0.2	104
0.3	69
0.4	52
0.5	42
1	21
3	7
6	3,5

3.1 PART IDENTIFICATION

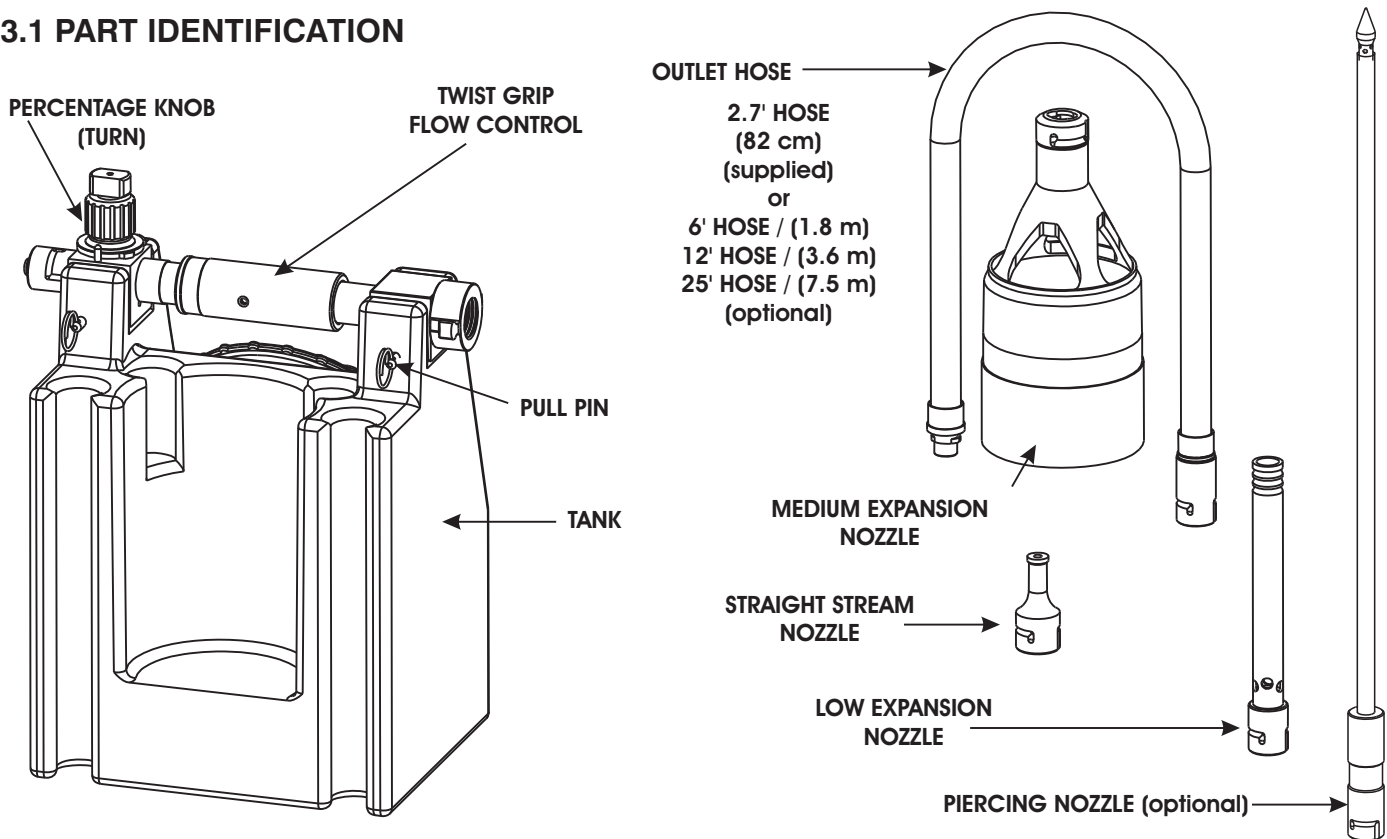

3.2 LEFT or RIGHT HAND OPERATION

The Control Block and Valve Assembly can be mounted on the Foam Tank for right or left hand operation. To switch hands, remove the Shoulder Strap from the Pull Pins. Remove the Circle Cotter from the Pull Pins and remove the Pull Pins themselves. Pull the Control Assembly straight up and out of the tank. Turn the Control Unit around and reinstall the Pull Pins, the Circle Cotter, and the Shoulder Strap.

4.0 FOAM SELECTION

In any eductor type system the accuracy of the foam concentrate to water ratio will depend upon the viscosity (thickness) of the foam concentrate. The more viscous, or thick, the foam concentrate, the greater the amount of energy required to draw the concentrate into the eductor. The viscosity of most foam concentrates changes with temperature, some thickening to a gel at temperatures of 40° F (4° C).

The PRO/pak percentage knob has two sides, the green Class A side was calibrated for 20 Centipoise Class A foam concentrates and the red, Class B, side was calibrated with National Foam's Universal Gold® AFFF concentrate.



Class A foam concentrates are generally less viscous than Class B foam concentrates. Do not use 1 percent Class B concentrates with the percentage knob set at 1 percent on the Class A side of the knob. Using 1% Class B foam on the 1% Class A setting may cause the actual percentage to be less than 1%.

Actual foam concentrations vary with changes in water flow, foam concentrate temperature and viscosity. The user must verify that the concentrate's performance is suitable for use in their application. In all cases, the manufacturer's recommendations must be followed.

4.1 CLASS A FOAM

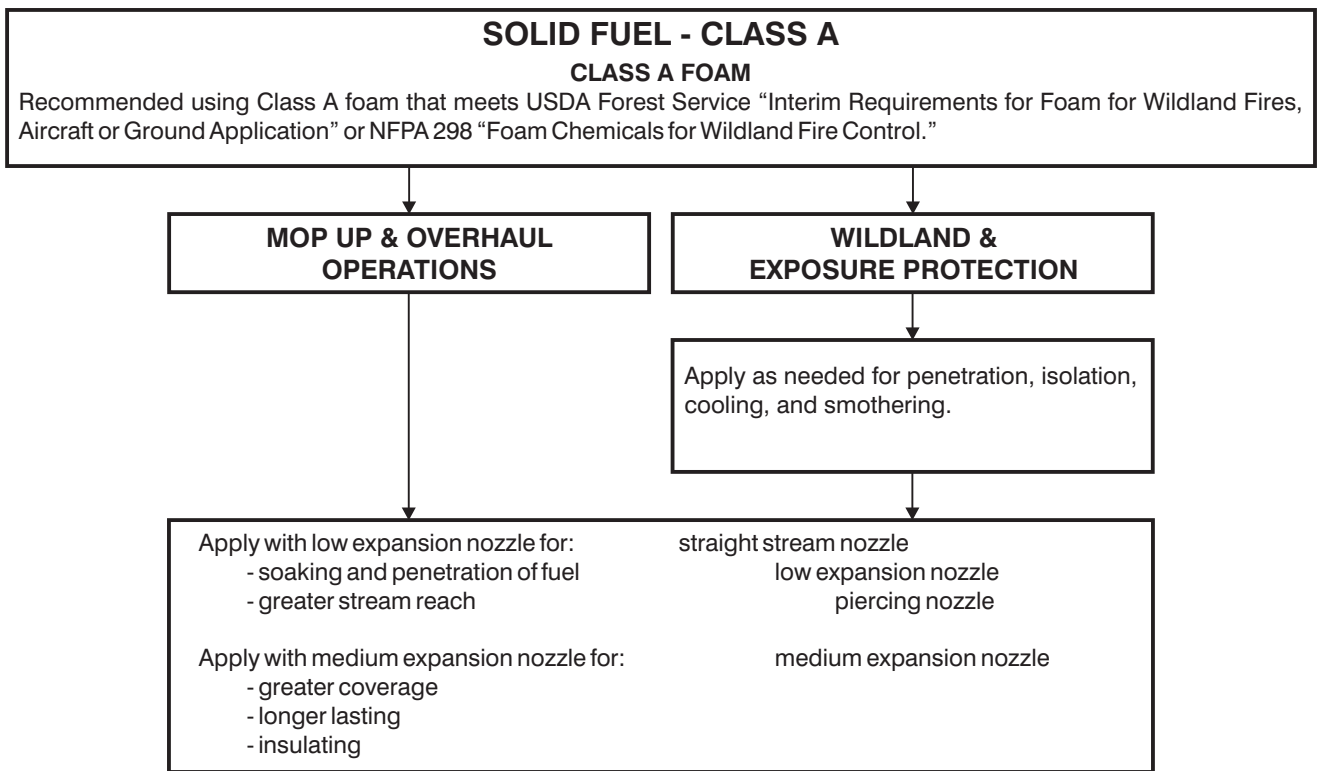

4.2 CLASS B FOAM

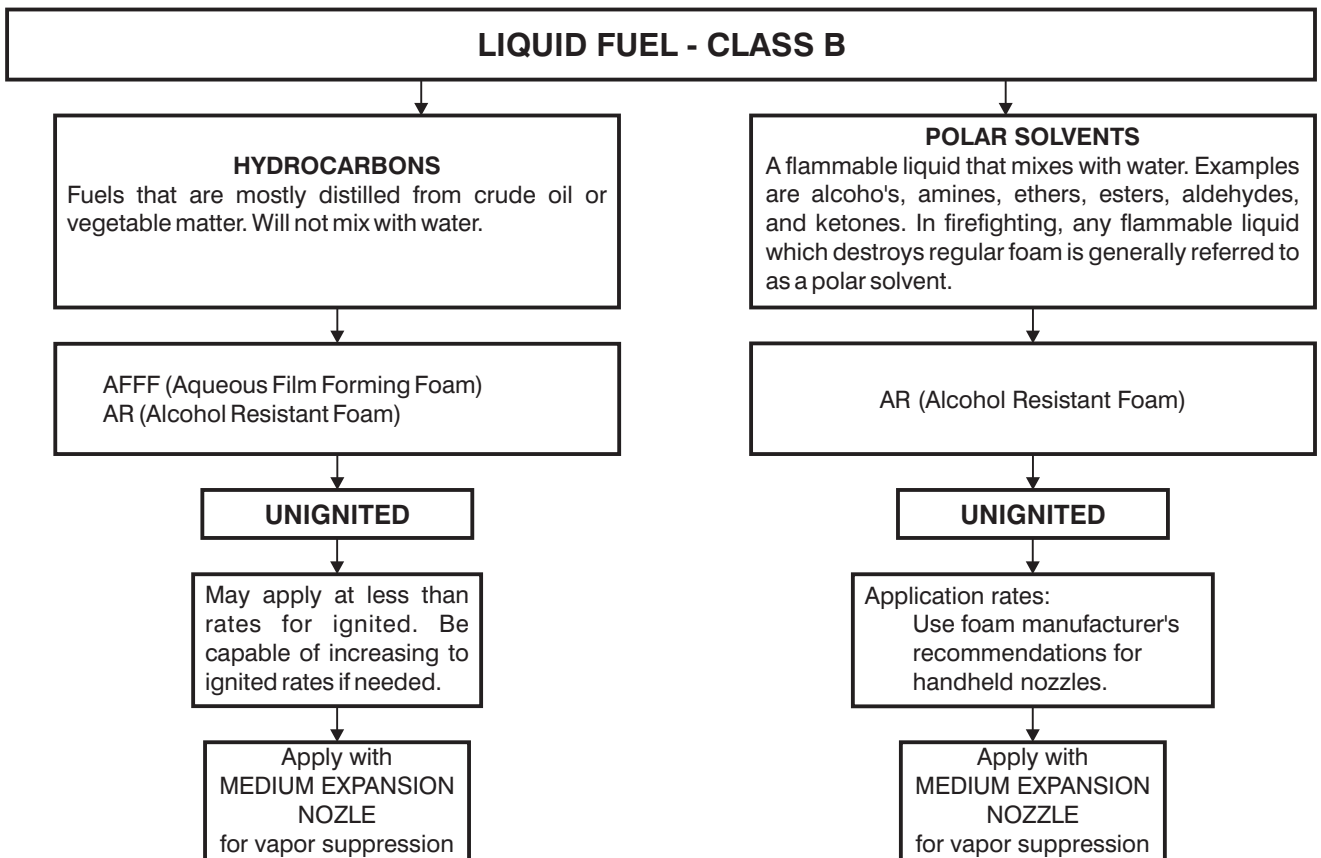

4.3 FOAM COMPATIBILITY

WARNING Do not mix different types of foam concentrates or foams of the same type from different manufacturers. Mixing of foam concentrates can cause the contents of the foam tank to gel and produce unpredictable results. Clean tank and foam passages thoroughly when changing foam types.

5.0 NOZZLE SELECTION

Straight Stream Nozzle — is for Class A foam solutions. Foam expansion will be negligible. It should be used where maximum reach or penetration is desired.

Low Expansion Nozzle — can be used with either Class A or B foam solutions. Reach is slightly less than the smooth bore. It should be used on Class B fires for extinguishment and Class A fuels to soak the fuel with a wet foam solution.

Medium Expansion Nozzle — produces the greatest expansion ratios. It should be used on Class B fuels for vapor suppression and Class A fuels when a longer lasting insulating layer of drier foam is desired.

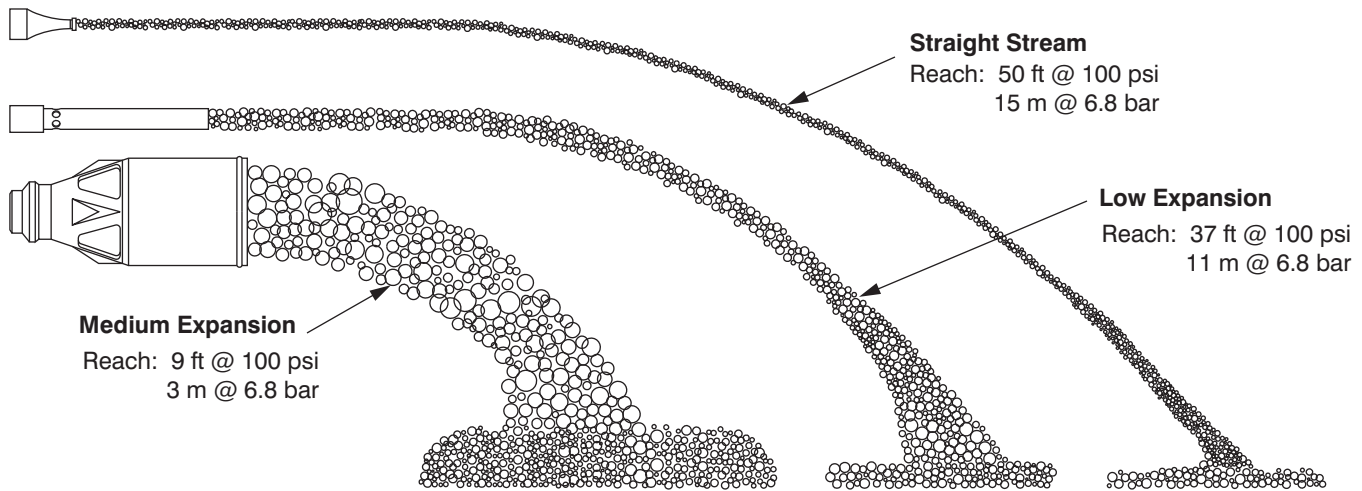

Piercing Nozzle — is for use with Class A foam solutions in deep-seated fires. Foam expansion will be negligible. It can be used where an application of solution is needed but the location is inaccessible. The piercing nozzle is not designed to pierce metal and other hard objects. To use behind hard surfaces, punch a hole first.

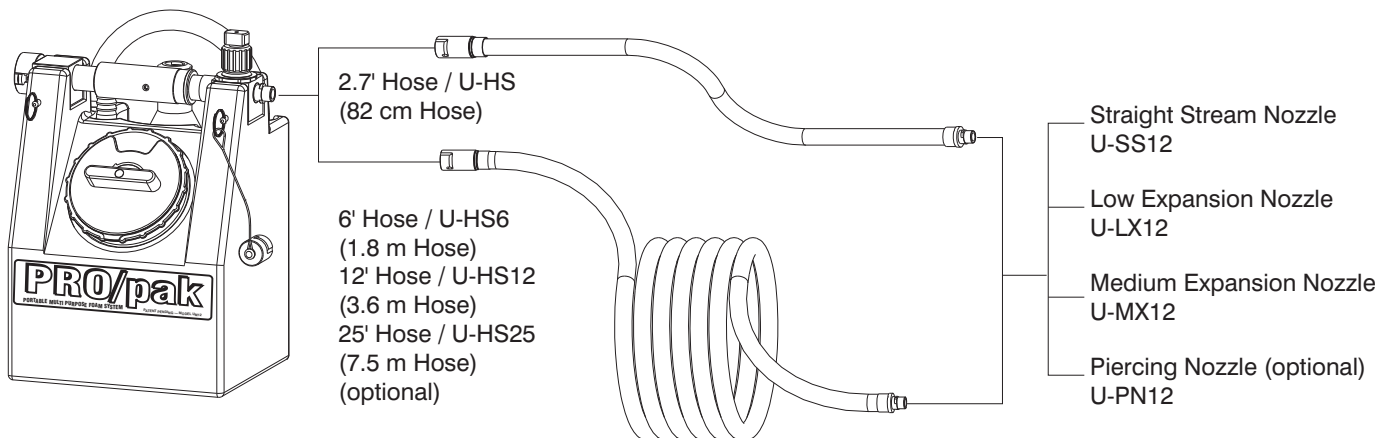

6.0 OPERATION

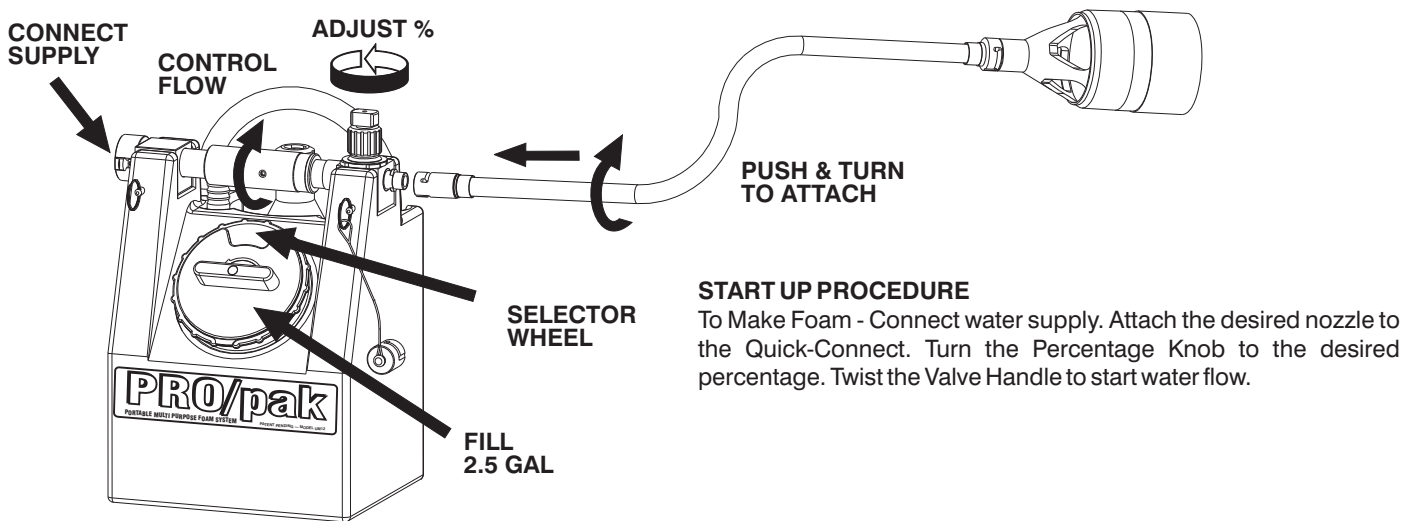

6.1 HOSE CONNECTION

Attach inlet fire hose to the coupling on the inlet end of the PRO/pak. Larger hoses may be used with an adapter. For maximum maneuverability, we recommend attaching 1" hose into the PRO/pak itself.

6.2 FILLING TANK

Unscrew the fill port lid by turning counterclockwise. Fill tank to bottom of fill port. Foam may seep out the vents if over filled. Close the fill port lid by turning clockwise. Set the selector wheel on the lid to indicate type of foam in the tank.

6.3 CONNECT DISCHARGE HOSE AND NOZZLE

1. Select the appropriate nozzle from the molded compartments on the side of the PRO/pak tank.
2. The nozzle may be attached directly to the quick-connect fitting on the control block or to the end of the outlet hose which is then attached to the control block. Align the marks on the quick-connect male fitting with the marks on the female fitting and push the two pieces together. Twist the nozzle or hose one quarter turn to the right to latch the quick-connect fitting.
3. Longer hose is available. TFT part U-HS6, U-HS12 and U-HS25.

CAUTION The PRO/pak's eductor will not work if the backpressure from the outlet hose or nozzle is too high. The 25' (7.5m) U-HS25 optional hose is the maximum length that will work with the PRO/pak. Adding additional hose, or using other hose assemblies and nozzles, may cause the PRO/pak to not function properly.

CAUTION There is no check valve in the PRO/pak eductor system. Do not install a shut off valve between the PRO/pak and the nozzle. This can cause the foam tank to fill with water and dilute the foam concentrate.

6.4 SETTING FOAM CONCENTRATION

Remove the nut on top of the percentage knob and lift the knob to select the proper foam concentrate type. Replace the knob nut. Turn the knob to the desired concentrate percentage. The percentage knob may be turned to the OFF position for water only use. Be sure to use the foam manufacturer's recommended concentrate ratio.

6.5 CONTROLLING FLOW

Pressurize the hose line. Turn the flow control valve to start water flowing through the PRO/pak. Flow may be reduced by partially closing the control valve.

6.6 FOAM QUALITY

Foam quality with the Medium Expansion Nozzle will depend upon the velocity of the foam solution exiting the nozzle. When pumping high pressures to the PRO/pak it may be necessary to partially close the flow control valve to make good foam with the Medium Expansion Nozzle. If the foam exiting the Medium Expansion Nozzle is not a coherent continuous stream, close the flow control valve slightly until the foam becomes a coherent continuous rope-like stream.

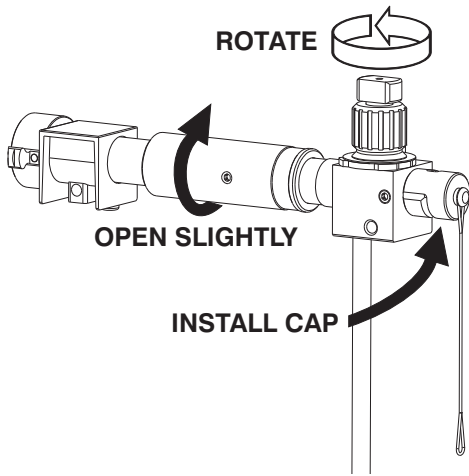

TO SHUT DOWN

To prevent concentrate from drying in the foam passages the following is recommended. While still connected to water supply, remove Circle Cotters and Pull Pins. Remove Control Unit from tank. Attach the Cap directly to the Quick-Connect on the Control Block. Turn the valve half way on till the discharge is foam free. This will back flush a small amount of water through the foam passage. Rotate the Percentage Knob back and forth to make sure all foam passages are flushed.

TO CLEAN OUT IF PLUGGED

Remove screw #2, spring #3, and knob #4. Inspect the underside of the knob. Make sure the foam passages are clear. Do not scratch the flat face of the knob. Inspect the 2 holes in the top of the Control Block #5. If they are plugged, pull pins #1, remove Block Assembly and clean out Pickup Tube and holes.

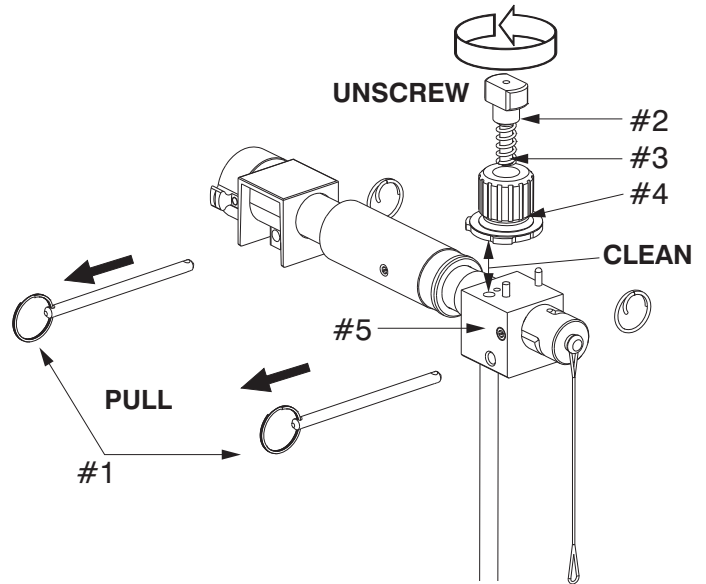

6.7 SHUT DOWN AFTER USE (FLUSHING)

PRO/pak should be flushed with water after each use to prevent foam concentrate from drying out inside of the Control Block and Percentage Knob.

- 1) Reduce pump pressure to 100 psi or less.
- 2) Remove the nozzle and/or hose from the quick-connect on the front of the Control Block.
- 3) Remove the Circle Cotters and pull out the two Pull Pins that hold the Control Unit to the tank.
- 4) Pull straight up to remove the Control Unit and Pickup Tube from the tank.
- 5) Make sure the Percentage Knob is NOT in the OFF position.
- 6) Install the Cap on the outlet of the Control Block.
- 7) Turn the Flow Control valve until a trickle of clean water is flowing out the end of the Pickup Tube.
- 8) Turn the Percentage Knob back and forth to make sure all foam passages are flushed.
- 9) Shut off water and reinstall the Control Unit on the tank and insert the Pull Pins and circle cotters.
- 10) Remove the Cap.

The exterior of the PRO/pak can be washed off with the hose or straight stream nozzle with the percentage knob in the OFF position.

6.8 STORAGE

The PRO/pak can be stored with foam concentrate in it. Make sure the control block and valve assembly is mounted on the tank and the fill port is securely closed to prevent evaporation. Storage in the upright position is recommended to avoid foam leaking when the PRO/pak is not in use. (See figure 6.8)

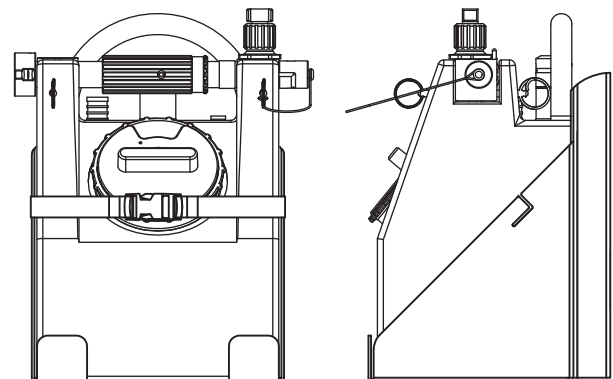

Figure 6.8
PRO/pak shown placed in a U-B mounting bracket in an upright position.

7.0 TROUBLE-SHOOTING

SYMPTOM	POSSIBLE CAUSE	REMEDY
PRO/pak will not make foam	Out Of Foam	Refill Tank
	Percentage Knob is OFF	Select desired percentage
	Percentage Knob is plugged	Remove screw on Percentage Knob, inspect and clean holes in top of control block and foam passages in bottom of Percentage Knob
	Non-standard outlet hose being used which is too long or too small in diameter	Order long hose option TFT part U-HS6 or U-HS25
	Foam tank is nearly empty	Refill tank
Foam is Intermittent	PRO/pak tilted	Keep Twist Grip Horizontal
	Air vents are plugged	Make sure that the small black rubber valve on the inside of the foam tank lid is not stuck down with dried foam concentrate
Poor Quality Foam	Debris in nozzle	Inspect nozzle, look for plugged holes
	Debris under knob	Unscrew Knob, inspect and clean
	Foam solution velocity too high	Partially close Flow Control
	Foam gets thick when cold	Select Another Foam

8.0 CLEAN UP AND MAINTENANCE

Turn the percentage knob to the OFF position. Use the hose, or hose and straight stream nozzle, to rinse off the PRO/pak. Reset percentage knob to proper percentage when finished.

For years of service, periodically inspect your PRO/pak. Make sure the hose and three nozzles are in place. Look for debris in the bottom of the tank and flush if necessary.

8.1 DRAIN HOLE

If the PRO/pak is often used for different foam concentrates, it may be helpful to install a drain to aid in emptying the tank. Drill and tap the left front ear of the tank and install a 1/4" NPT Pipe plug. Plastic or Brass preferred.

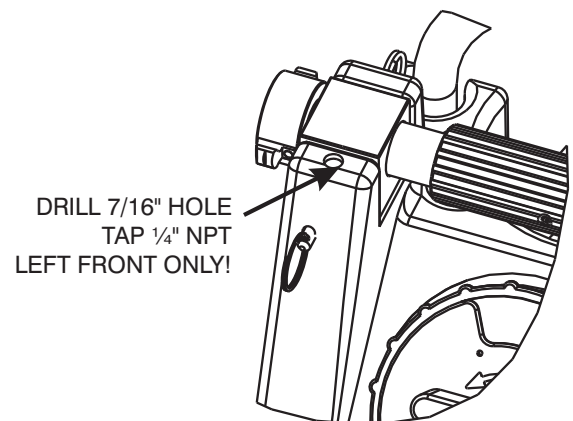

9.0 SPECIFICATIONS

	U.S. Units	Metric Units
Tank Capacity (to bottom of fill port)	2.5 U.S. gallons	9.5 liters
Nominal flow (all nozzles)	12 gpm at 100 psi	45 l/min at 6.8 bar
Weight Empty	11.5 lb	5.2 kg
Weight Full	30.1 lb	13.6 kg
Length x Width x Height	13.5 x 10.75 x 17 in	345 x 275 x 430 mm
Operating Pressure Max/Min	500/40 psi	40/3 bar
Straight Stream Nozzle Reach	50 feet at 100 psi	15 meters at 6.8 bar
Low Expansion Nozzle Reach	37 feet at 100 psi	11 meters at 6.8 bar
Medium Expansion Nozzle Reach	9 feet at 100 psi	3 meters at 6.8 bar

10.0 DRAWINGS AND PARTS LIST

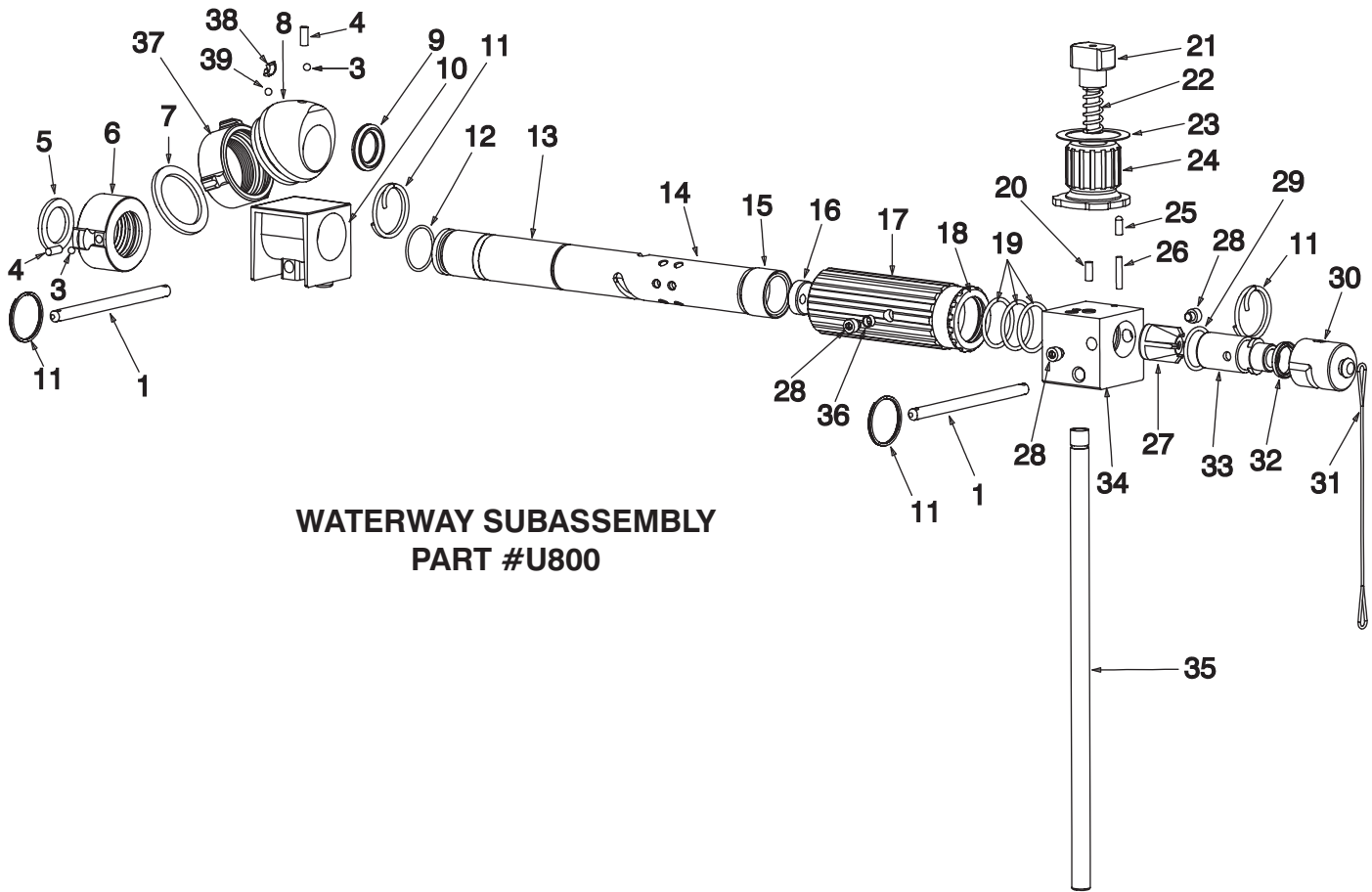

**WATERWAY SUBASSEMBLY
PART #U800**

#	DESCRIPTION	QTY	PART #
1	Pull Pin	2	U180
3	3/16 SS Balls	21	V2120
4	1/4-28 x 1/2 Set Screw	1	VT25-28SS500
5	1.0 Hose Gasket	1	V3040
6	1.0 Coupling*	1	U260*
7	1.5 Hose Gasket	1	V3130
8	Angled Swivel	1	U265
9	Quad Seal	1	VOQ-4316
10	Rear Block	1	U270
11	Circle Cotter	4	U182
12	024 O-Ring	1	VO-024
13	Handle	1	U240
14	Flow Label	1	UL500
15	022 O-Ring	1	VO-022
16	Handle Plug	1	U241
17	Valve	1	U250
18	Valve Pointer Label	1	UL504
19	124 O-Ring	3	VO-124
20	1/4-20x3/4 Stud	1	U223
21	Knob Nut	1	U221
22	Knob Spring	1	U222

#	DESCRIPTION	QTY	PART #
23	Percent Knob Label	1	UL505
24	Percentage Knob	1	U230
25	Vinyl Cap	1	VM1030
26	Spirol Pin	1	V1900
27	Rear Venturi Insert	1	U214
28	Dog Point Screw	4	H515
29	120 O-Ring	1	VO-120
30	Venturi Cap	1	U213
31	Cable Assembly	1	VM1020
32	Cup Seal	1	U212
33	Front Venturi Insert	1	U210
34	Control Block	1	U200
35	Foam Pick Up Tube	1	U202
36	Follower	2	U251
37	1.5 Coupling *	1	F10097*
38	Port Plug	1	B770
39	3/16 SS Balls	34	V2120

* Specify Hose Thread Required

10.0 DRAWINGS AND PARTS LIST (continued)

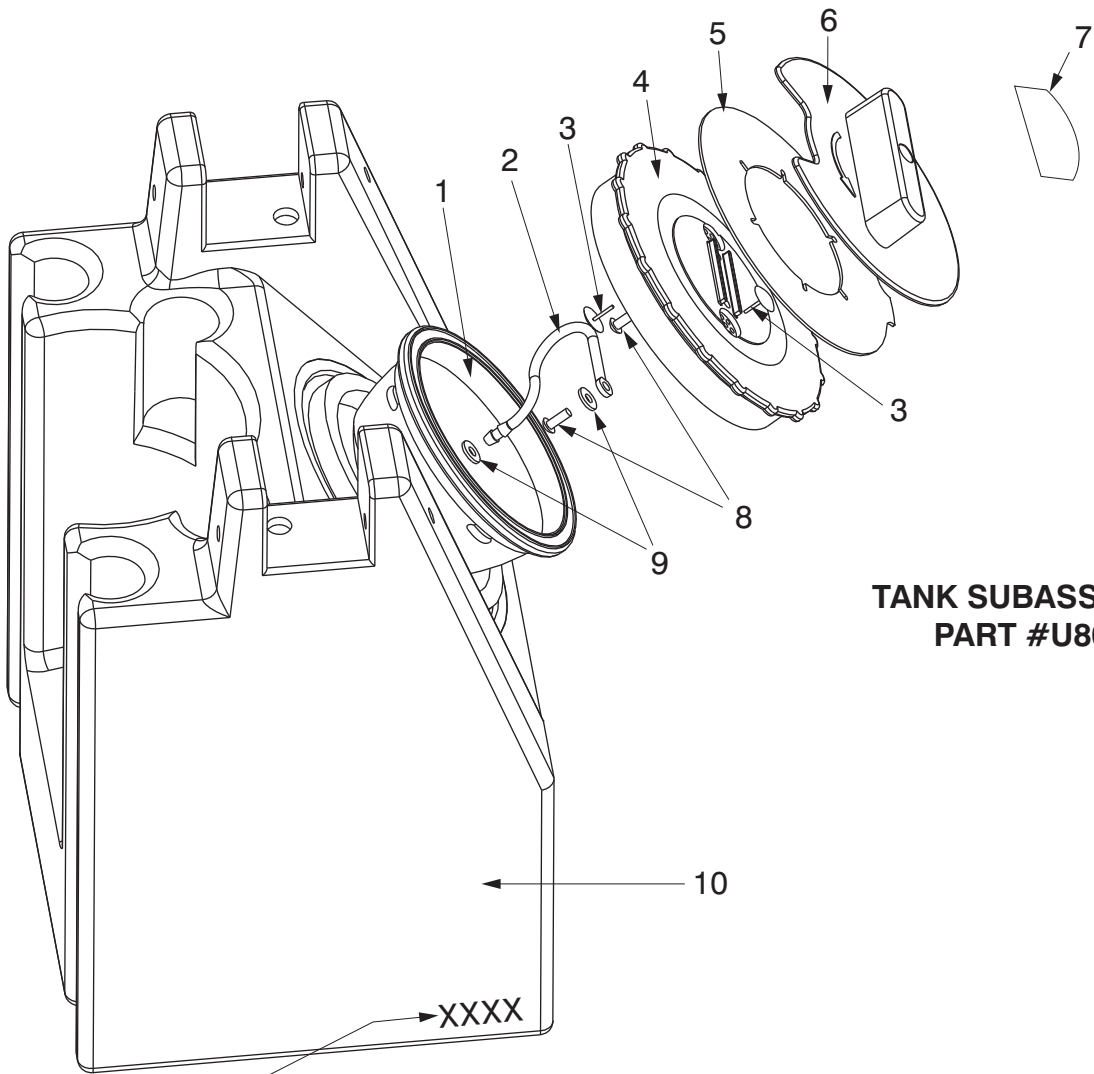

**TANK SUBASSEMBLY
PART #U805***

- *
 UL503 - TANK GRAPHIC-ENGLISH
 UL503-F TANK GRAPHIC-FRENCH
 UL503-G TANK GRAPHIC-GERMAN
 UL503-I TANK GRAPHIC-ITALIAN
 UL503-J TANK GRAPHIC-JAPANESE
 UL503-M TANK GRAPHIC-METRIC
 UL503-P TANK GRAPHIC-PORTUGUESE
 UL503-R TANK GRAPHIC-RUSSIAN
 UL503-S TANK GRAPHIC-SPANISH

#	DESCRIPTION	QTY	PART #
1	Filter Screen	1	U165
2	Filport Leash	1	U166
3	Valve Umbrella	2	VM4290
4	Screen On Lid	1	U170
5	Contents Wheel	1	UL501
6	Fill Port Handle	1	U161
7	Name Label	1	UL521
8	10-24 x 5/8 SS Screw	2	VT10-24BH625
9	SS Washers	3	VW500X203-60
10	Tank	1	U100*

*Specify Language using identification number on tank graphic

10.0 WARRANTY

Task Force Tips, Inc., Valparaiso, Indiana 46383-9511 ("TFT") warrants to the original purchaser of its PRO/pak Portable Foam System ("equipment"), and to anyone to whom it is transferred, that the equipment shall be free from defects in material and workmanship during the five (5) year period from the date of purchase.

TFT's obligation under this warranty is specifically limited to replacing or repairing the equipment (or its parts) which are shown by TFT's examination to be in a defective condition attributable to TFT. To qualify for this limited warranty, the claimant must return the equipment to TFT, at 2351 Industrial Drive, Valparaiso, Indiana 46383-9511, within a reasonable time after discovery of the defect. TFT will examine the equipment. If TFT determines that there is a defect attributable to it, it will correct the problem within a reasonable time. If the equipment is covered by this limited warranty, TFT will assume the expenses of repair.

If any defect attributable to TFT under this limited warranty cannot be reasonably cured by repair or replacement, TFT may elect to refund the purchase price of the equipment, less reasonable depreciation, in complete discharge of its obligations under this limited warranty. If TFT makes this election, claimant shall return the equipment to TFT free and clear of any liens and encumbrances.

This is a limited warranty. The original purchaser of the equipment, any person to whom it is transferred, and any person who is an intended or unintended beneficiary of the equipment, shall not be entitled to recover from TFT any consequential or incidental damages for injury to person and/or property resulting from any defective equipment manufactured or assembled by TFT. It is agreed and understood that the price stated for the equipment is in part consideration for limiting TFT's liability. Some states do not allow the exclusion or limitation of incidental or consequential damages, so the above may not apply to you.

TFT shall have no obligation under this limited warranty if the equipment is, or has been, misused or neglected (including failure to provide reasonable maintenance) or if there have been accidents to the equipment or if it has been repaired or altered by someone else.

THIS IS A LIMITED EXPRESS WARRANTY ONLY. TFT EXPRESSLY DISCLAIMS WITH RESPECT TO THE EQUIPMENT ALL IMPLIED WARRANTIES OF MERCHANTABILITY AND ALL IMPLIED WARRANTIES OF FITNESS FOR A PARTICULAR PURPOSE. THERE IS NO WARRANTY OF ANY NATURE MADE BY TFT BEYOND THAT STATED IN THE DOCUMENT.

This limited warranty gives you specific legal rights, and you may also have other rights which vary from state to state.

TASK FORCE TIPS, Inc.
MADE IN USA • www.tft.com

2351 Industrial Drive, Valparaiso, IN 46383-9511 USA
800-348-2686 • 219-462-6161 • Fax 219-464-7155