

INSTRUCTIONS FOR SAFE OPERATION AND MAINTENANCE

⚠️ WARNING

Understand manual before use. Operation of this device without understanding the manual and receiving proper training is a misuse of this equipment. Obtain safety information at www.tft.com/serial-number

This instruction manual is intended to familiarize firefighters and maintenance personnel with the operation, servicing and safety procedures associated with the Metro 1 & 2 fire fighting nozzles.

This manual should be kept available to all operating and maintenance personnel.

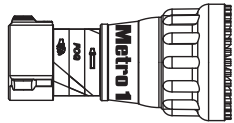

ME1-TO

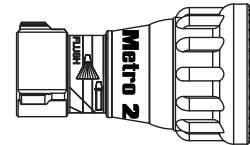

ME2-TO

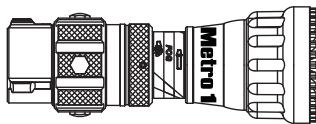

ME1-STO

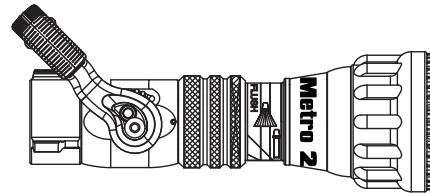

ME2-V

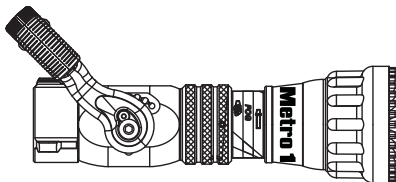

ME1-V

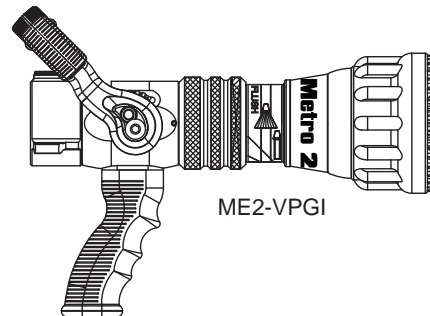

ME2-VPGI

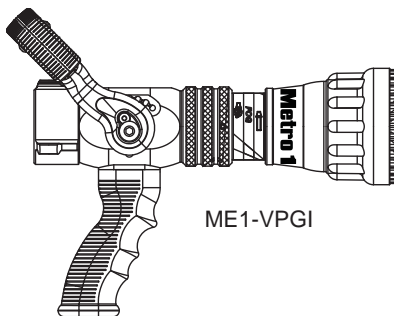

ME1-VPGI

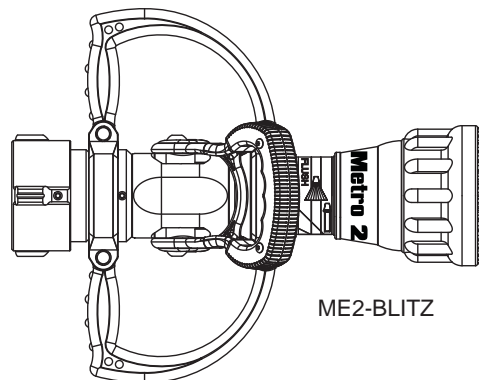

ME2-BLITZ

Table Of Contents

1.0	MEANING OF SAFETY SIGNAL WORDS.....	3
2.0	GENERAL INFORMATION	3
2.1	VARIOUS MODELS AND TERMS	
2.2	COLOR CODED VALVE HANDLE AND PISTOL GRIP	
2.3	MECHANICAL SPECS	
2.4	NOZZLE COUPLING	
3.0	FLOW CHARACTERISTICS.....	5
3.1	FLOW SETTING	
3.2	WASHER SETTING	
4.0	NOZZLE CONTROLS.....	7
4.1	FLOW CONTROL	
4.1.1	LEVER TYPE FLOW CONTROL	
4.1.2	TWIST SHUTOFF	
4.1.3	TIP ONLY NOZZLES	
4.2	BALL VALVE SHUTOFF	
4.3	PATTERN CONTROL	
4.4	FLUSH CONTROL	
4.5	USE WITH FOAM	
4.5.1	FOAM ASPIRATING ATTACHMENTS	
5.0	USE OF METRO NOZZLES	9
6.0	FIELD INSPECTION	9
7.0	REPAIR	9
8.0	ANSWERS TO YOUR QUESTIONS.....	9
9.0	METRO 1 DRAWINGS AND PARTS LIST.....	10
10.0	METRO 2 DRAWINGS AND PARTS LIST.....	13
11.0	INSPECTION CHECKLIST	Back Cover
12.0	WARRANTY.....	Back Cover



PERSONAL RESPONSIBILITY CODE

The member companies of FEMSA that provide emergency response equipment and services want responders to know and understand the following:

1. Firefighting and Emergency Response are inherently dangerous activities requiring proper training in their hazards and the use of extreme caution at all times.
2. It is your responsibility to read and understand any user's instructions, including purpose and limitations, provided with any piece of equipment you may be called upon to use.
3. It is your responsibility to know that you have been properly trained in Firefighting and /or Emergency Response and in the use, precautions, and care of any equipment you may be called upon to use.
4. It is your responsibility to be in proper physical condition and to maintain the personal skill level required to operate any equipment you may be called upon to use.
5. It is your responsibility to know that your equipment is in operable condition and has been maintained in accordance with the manufacturer's instructions.
6. Failure to follow these guidelines may result in death, burns or other severe injury.



Fire and Emergency Manufacturers and Service Association
P.O. Box 147, Lynnfield, MA 01940 • www.FEMSA.org

1.0 MEANING OF SAFETY SIGNAL WORDS

A safety related message is identified by a safety alert symbol and a signal word to indicate the level of risk involved with a particular hazard. Per ANSI standard Z535.6-2007, the definitions of the four signal words are as follows:



DANGER indicates a hazardous situation which, if not avoided, will result in death or serious injury.



WARNING indicates a hazardous situation which, if not avoided, could result in death or serious injury.



CAUTION indicates a potentially hazardous situation which, if not avoided, may result in minor or moderate injury.



NOTICE is used to address practices not related to personal injury.

2.0 GENERAL INFORMATION

The Task Force Tips Metro nozzles are designed to provide excellent performance under most fire fighting conditions. Their rugged construction is compatible with the use of fresh water (see Section 6.0 for saltwater use) as well as fire fighting foam solutions. Other important operating features are: Interchangeable washer to allow for user defined flow and pressure; Quick-acting pattern control from straight stream to wide fog; "Power fog teeth" for full-fill fog; Easily flushable while flowing to clear trapped debris; TFT's five-year warranty and unsurpassed customer service.



This equipment is intended for use by trained personnel for firefighting. Their use for other purposes may involve hazards not addressed by this manual. Seek appropriate guidance and training to reduce risk of injury.



Nozzle reaction will vary as supply conditions change: such as opening or closing other nozzles, hose line kinks, changes in pump settings, etc. Changes in spray pattern or flushing will also affect nozzle reaction. The nozzle operator must always be prepared in the event of those changes. Failure to restrain nozzle reaction can cause firefighter injury from loss of footing and/or stream protection.



If nozzle gets out of control or away from operator, retreat from nozzle immediately. Do not attempt to regain control of nozzle while flowing water. Injury from whipping can occur.



Water is a conductor of electricity. Application of water solutions on high voltage equipment can cause injury or death by electrocution. The amount of current that may be carried back to the nozzle will depend on the following factors: Voltage of the line or equipment; Distance from the nozzle to the line or equipment; Size of the stream; Whether the stream is solid or broken; Purity of the water¹



Fire streams are capable of injury and damage. Do not direct water stream to cause injury or damage to persons or property.



The nozzle may become damaged if allowed to freeze while containing water. Always drain after use to avoid damage and possible loss of use.

¹ The Fire Fighter and Electrical Equipment, The University of Michigan Extension Service, Fourth Printing 1983. Page 47.

2.1 VARIOUS MODELS AND TERMS

Fixed Flow: A nozzle with a discharge orifice that is a fixed opening size.

Tip Only: a nozzle without an integral ball shutoff valve. A Metro tip only nozzle is available in a variety of flow ranges and configurations. All models deliver the rated flow when the rated pressure is supplied to the nozzle.

SERIES	RECOMMENDED MIN HOSE DIA.	FLOW SETTINGS	NOZZLE TYPE
METRO 1 (small body)	1-1/2	Field Changeable To Any of 14 Sizes	Fixed Flow
METRO 2 (large body)	1-1/2 to 2-1/2	Field Changeable To Any of 10 Sizes	Fixed Flow

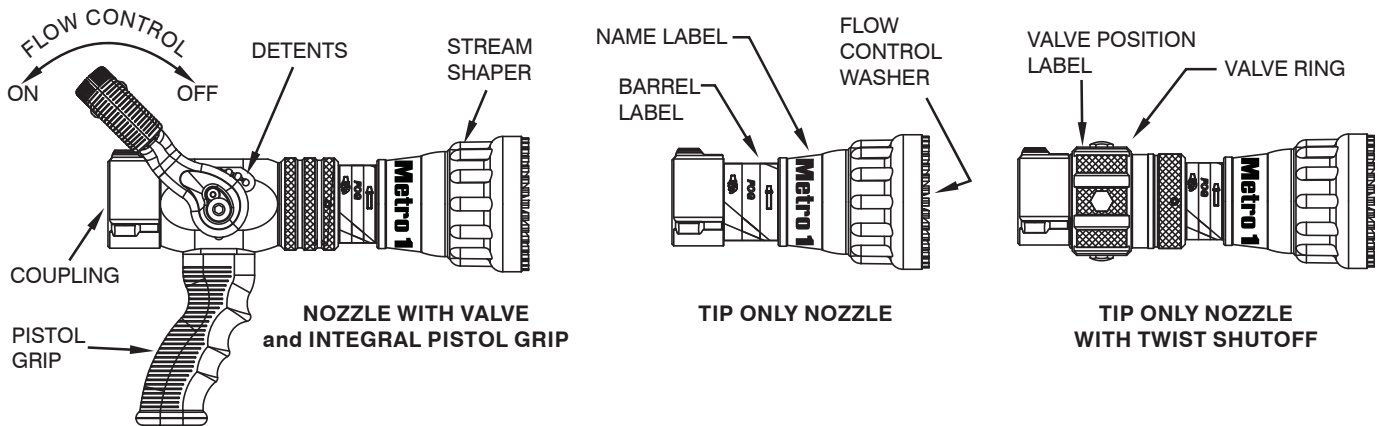

Figure 1
Common Model and Terms

2.2 COLOR CODED VALVE HANDLE AND PISTOL GRIP

The TFT METRO Nozzles with lever type valve handles are supplied with black valve handle covers and pistol grips. The handle covers and pistol grips are available from TFT in various colors for those departments wishing to color code the nozzle to the discharge controls. A colored handle cover set will be sent upon receipt of the warranty card by TFT. Your department's name can also be engraved on the covers (see warranty card for more information).

Handle covers are replaceable by removing the four screws that hold the handle covers in place. Use a 3/32" allen wrench when replacing screws. Pistol grip is replaceable by following TFT instruction sheet LTT-108.

For standardization NFPA 1901 (A-4-9.3) recommends the following color code scheme:

Preconnect #1 or Bumper Jump Line	Orange	Other Colors Available:
Preconnect or discharge #2	Red	• Gray
Preconnect or discharge #3	Yellow	• Pink
Preconnect or discharge #4	White	• Purple
Preconnect or discharge #5	Blue	• Tan
Preconnect or discharge #6	Black	
Preconnect or discharge #7	Green	
Foam Lines	Red w/ White border (Red/White)	

2.3 MECHANICAL SPECIFICATIONS

Maximum nozzle inlet pressure with valve shutoff	Metro 1 300 psi	21 bar
	Metro 2 300 psi	21 bar
Operating temperature range of fluid	33 to 120° F	1 to 50° C
Storage temperature range	-40 to 150° F	-40 to 65° C
Materials used	Aluminum 6000 series hard anodized MIL8625 class 3 type 2, stainless steel 300 series, nylon 6-6, nitrile rubber	

2.4 NOZZLE COUPLING

NH (National Hose Threads per NFPA #1963) threads are standard on all nozzles. Other threads such as NPSH (National Pipe Straight Hose threads per ANSI/ASME #B1.20.7) can be specified at time of order.

CAUTION Nozzle must be mated to a hose line with matched threads. Mismatched or damaged threads may cause nozzle to leak or uncouple from hose under pressure and could cause injury.

CAUTION Do not couple aluminum to brass. Dissimilar metals coupled together can cause galvanic corrosion that can result in inability to unscrew threads or complete loss of thread engagement.

CAUTION Dissimilar metals coupled together can cause galvanic corrosion that can result in the inability to unscrew the threads or complete loss of thread engagement over time. Per NFPA 1962 (2008 edition), if dissimilar metals are left coupled together an anti-corrosive lubricant should be applied to the threads. Also the coupling should be disconnected and inspected at least quarterly.

3.0 FLOW CHARACTERISTICS

The opening size of the Metro nozzles may be field set to any one of the several different sizes. At each flow setting the nozzle is set to a predetermined fixed orifice. Relationship of flow and nozzle pressure at each setting is shown below.

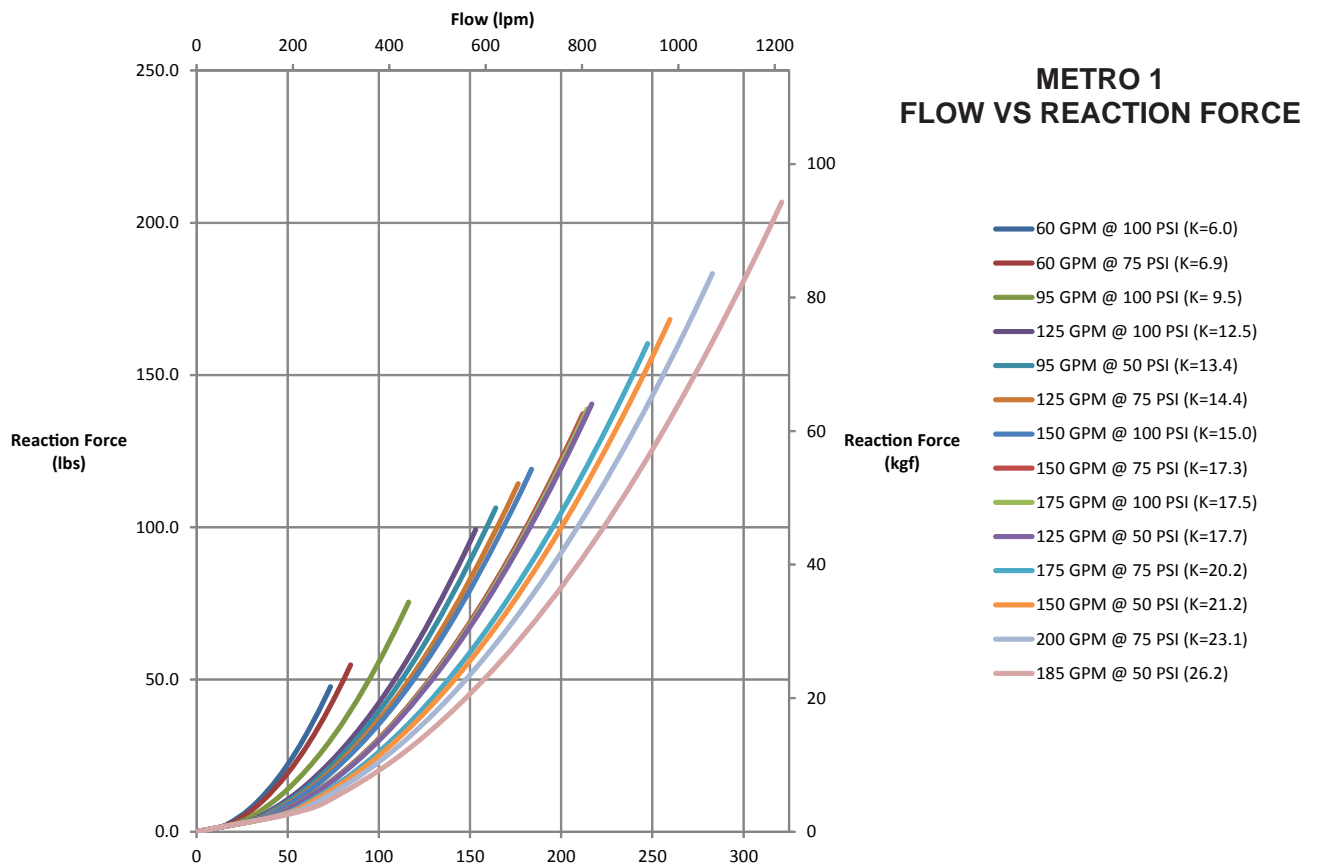
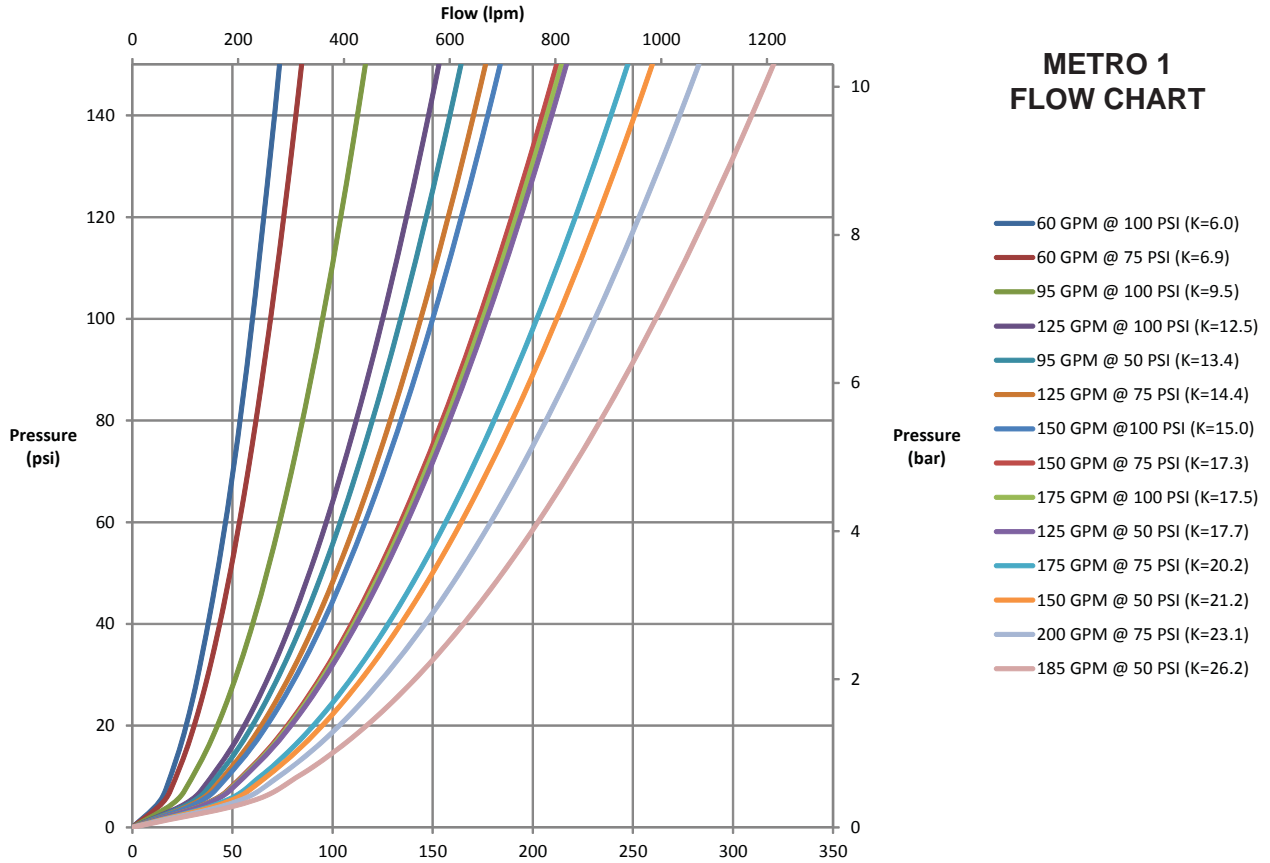

METRO 2 FLOW CHART

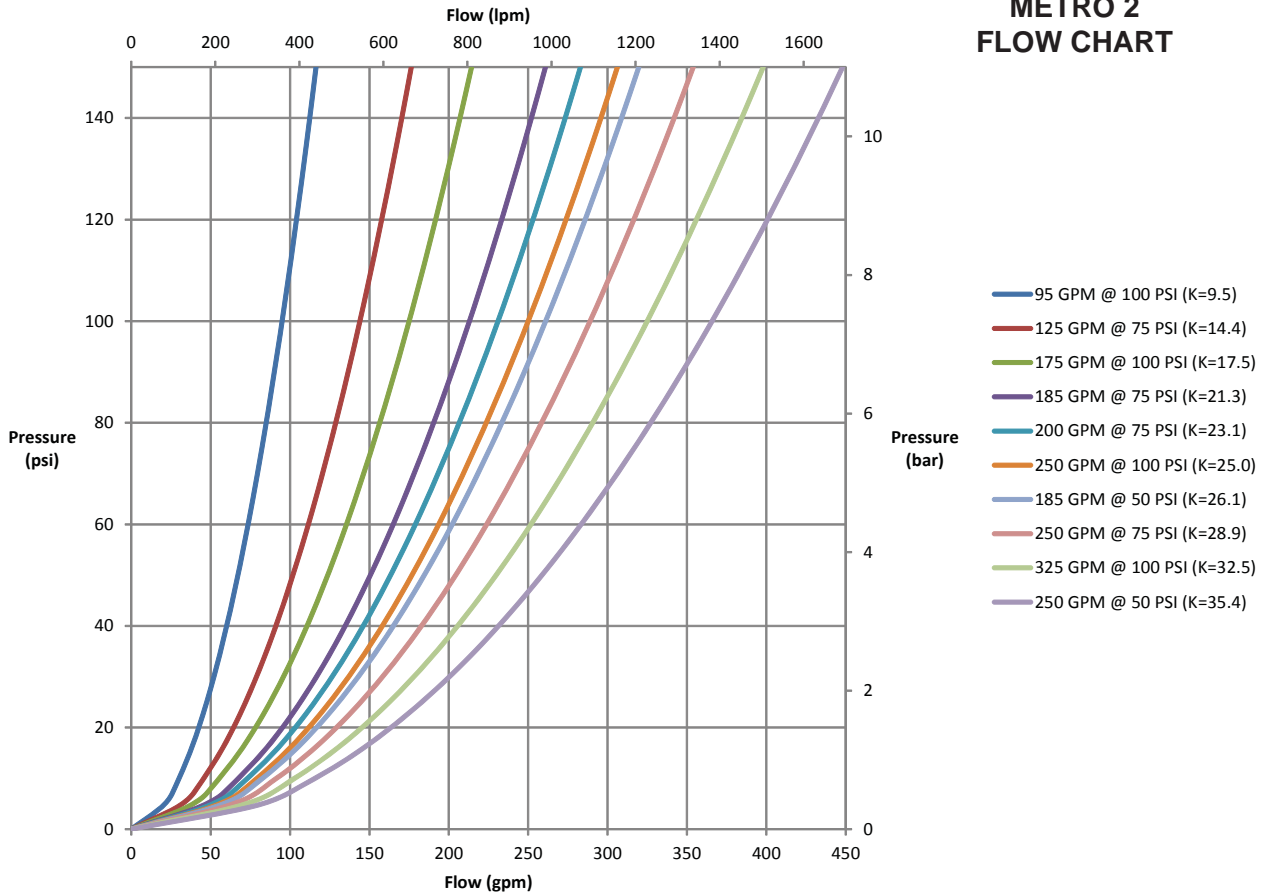

METRO 2 FLOW VS REACTION FORCE

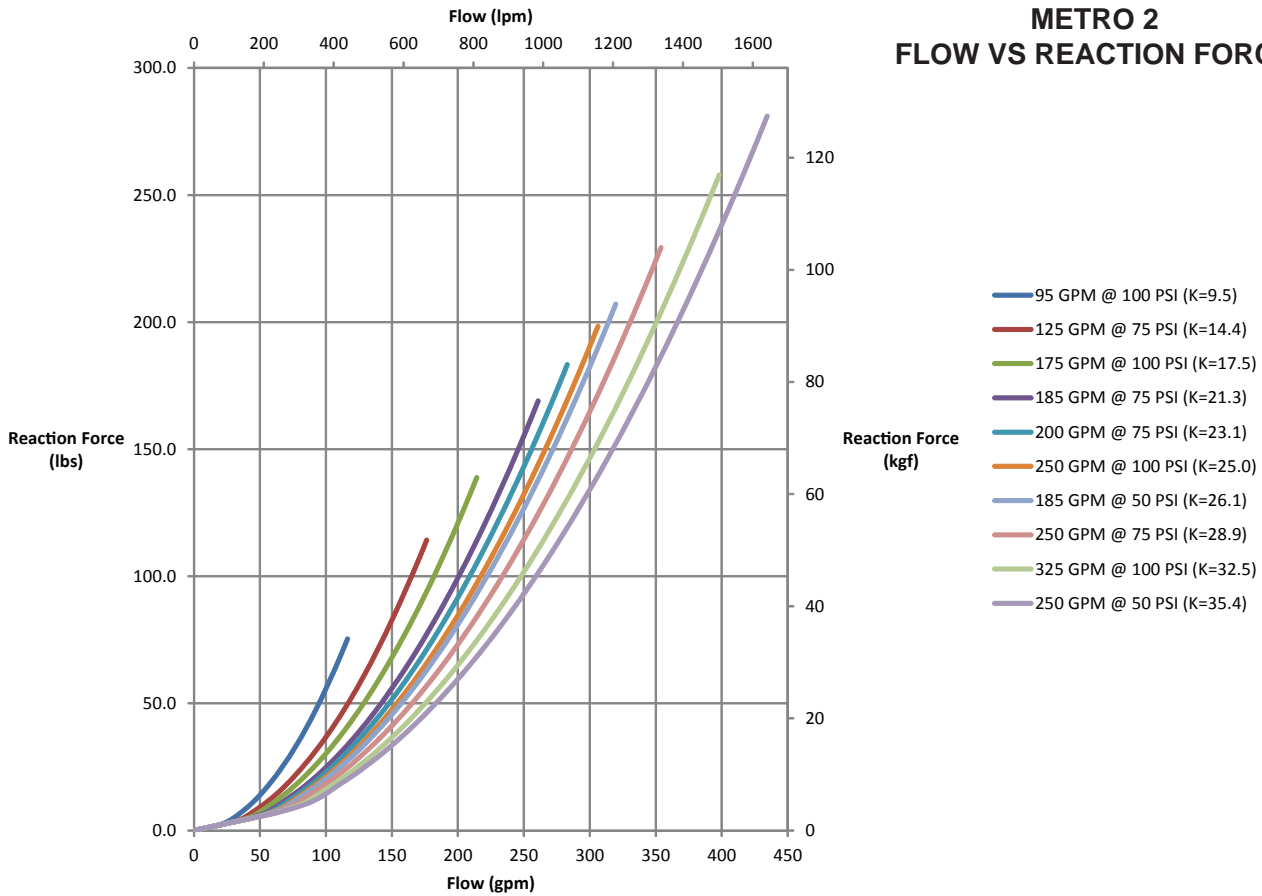

3.1 FLOW SETTING

The washers are marked with various flow settings. Change washer to the desired setting. **The nozzle will flow the indicated amount when the pressure at the nozzle is at the indicated level.**

3.2 WASHER SETTING

To change flow and pressure setting of the Metro, use the following instructions:

- 1) Set nozzle into FLUSH.
- 2) Push baffle down to barrel cone.
- 3) Remove screw and washer using a 5/32 hex key.
- 4) Remove pre-set flow washer and slide desired flow washer onto shaft, desired flow marking facing up.
- 5) Thread screw with washer back into shaft until snug (Do not over tighten).

NOTE: H410-** are not compatible with new Metro 2 nozzles

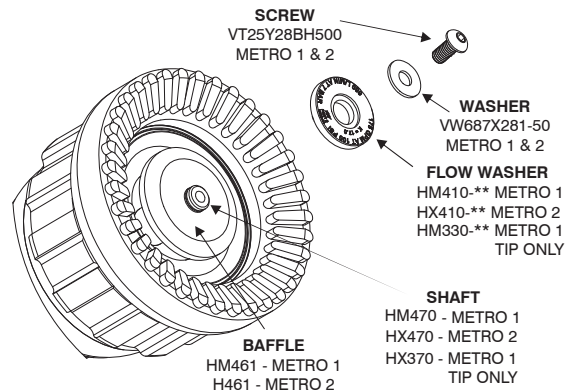

⚠ DANGER An inadequate supply of nozzle pressure and/or flow will cause an ineffective stream and can result in injury, death or loss of property. See flow chart in section 8.0 or call 800-348-2686 for assistance.

⚠ WARNING Failure to secure screw and washer will result in the baffle becoming loose. This will produce poor stream, improper flows and possible discharge of the complete baffle, resulting in risk of injury.

⚠ WARNING Failure to restrain nozzle reaction can cause firefighter injury from loss of footing and/or stream protection. Nozzle reaction will vary as supply conditions change: such as opening or closing other nozzles, hose line kinks, changes in pump settings, etc. Changes in spray pattern or flushing will also affect nozzle reaction. The nozzle operator must always be positioned to restrain the nozzle reaction in the event of those changes.

⚠ WARNING Injury from whipping can occur. If nozzle gets out of control or away from operator, retreat from nozzle immediately. Do not attempt to regain control of nozzle while flowing water.

⚠ CAUTION Fire streams are capable of injury and damage. Do not direct water stream to cause injury or damage to persons or property.

4.0 NOZZLE CONTROLS

4.1 FLOW CONTROL

4.1.1 LEVER TYPE FLOW CONTROL

On models that use a lever type valve handle, the nozzle is shut off when the handle is fully forward. The valve handle has six detent flow positions. These detent positions allow the nozzle operator to regulate the flow of the nozzle depending on the need or what can be safely and effectively handled. TFT recommends the use of a pistol grip for easier handling. For additional stress reduction, a hose rope or strap may also be used. This permits more effective use and ease of advancement, while minimizing strain and fatigue.

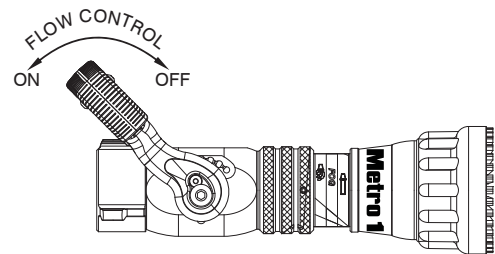

4.1.2 TWIST SHUTOFF

On models that use a twist flow control, the valve is opened or closed by rotating the valve ring. Rotating the ring clockwise (as seen from the operating position behind the nozzle) closes the valve, while counterclockwise rotation opens it. Detents are provided at four intermediate positions and the position of the valve is shown by the exposed valve position label.

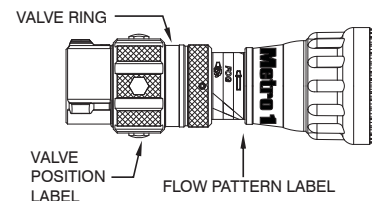

4.1.3 TIP ONLY NOZZLES

Tip only nozzles have NO shut off valve contained within the nozzle and MUST be used with a separate ball valve attached to the nozzle.

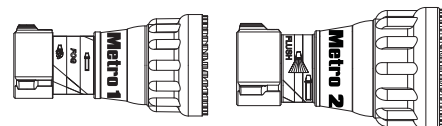

4.2 BALL VALVE SHUTOFF

Models with a ball valve are shut off when the valve handle is fully forward. Pulling back on the handle opens the valve. Open valve slowly to avoid sudden changes in nozzle reaction. Close valve slowly to prevent water hammer. Note: In partially open positions a ball valve will cause turbulence and adversely affect stream quality.

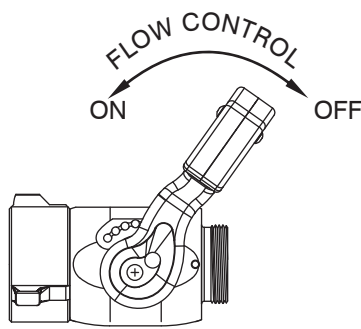

The notch in the ball is designed to reduce turbulence through a partially opened valve and does not affect shutoff.

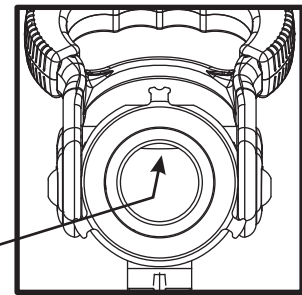

4.3 PATTERN CONTROL

TFT's Metro has full pattern control from straight stream to wide fog. Turning the STREAM SHAPER clockwise (as seen from the operating position behind the nozzle) moves the SHAPER to the straight stream position. Turning the SHAPER counterclockwise will result in an increasingly wider pattern.

Since the stream trim point varies with the flow, the stream should be "trimmed" after changing the flow to obtain the straightest and farthest reaching stream. To properly trim a stream, first open the pattern to a narrow fog. Then close the stream to parallel to give maximum reach. NOTE: Turning the shaper further forward will cause stream crossover and reduce the effective reach of the nozzle.

The nozzle reaction is greatest when the shaper is in the straight stream position. The nozzle operator must be prepared for a change in reaction as the pattern is changed.

4.4 FLUSH CONTROL

Small debris may get caught inside the nozzle. This trapped material will cause poor stream quality, shortened reach and reduced flow. To remove this trapped debris the nozzle can be flushed as follows; while still flowing water, turn the SHAPER counterclockwise past the full fog position (increased resistance will be felt on the SHAPER as the nozzle goes into flush). This will open the nozzle allowing debris to pass through. Rotate the SHAPER clockwise and out of flush to continue normal operation. During flush the nozzle reaction will decrease as the pattern becomes wider and the pressure drops. The nozzle operator must be prepared for an increase of nozzle reaction when returning the nozzle from the flush position to retain control of the nozzle.

WARNING Large amounts of debris can reduce the flow of the nozzle resulting in an ineffective flow. In the event of a blockage it may be necessary to retreat to a safe area, uncouple nozzle and remove debris.

4.5 USE WITH FOAM

The Metro nozzles may be used with foam solutions. Refer to fire service training for the proper use of foam.

WARNING For Class B fires, lack of foam or interruption in the foam stream can cause a break in the foam blanket and greatly increase the risk of injury or death. Assure that: Application rate is sufficient (see NFPA 11 or foam manufacturer's recommendations); Enough concentrate is on hand to complete task (see NFPA for minimum duration time requirements); Foam logistics have been carefully planned. Allow for such things as: Storage of foam in a location not exposed to the hazard it protects; Personnel, equipment and technique to deliver foam at a rapid enough rate; Removal of empty foam containers; Clear path to deliver foam, as hoses and other equipment and vehicles are deployed.

WARNING Improper use of foam can result in injury or damage to the environment. Follow foam manufacturer's instructions and fire service training to avoid: Using wrong type of foam on a fire, i.e. Class A foam on a Class B fire; Plunging foam into pools of burning liquid fuels; Causing environmental damage; Directing stream at personnel.

WARNING There is a wide variety of foam concentrates. Each user is responsible for verifying that any foam concentrate chosen to be used with this unit has been tested to assure that the foam obtained is suitable for the purpose intended.

4.5.1 FOAM ASPIRATING ATTACHMENTS

To increase the expansion ratio, Task Force Tips "MX Foamjet" (model FJ-MX-HM) multi expansion attachment or LX Foamjet (model FJ-LX-HM) low expansion attachment may be used with the Metro 1 nozzle and (model FJ-HMX) multi expansion attachment or LX Foamjet (model FJ-H) low expansion attachment may be used with the Metro 2 nozzle. These foam tubes attach and detach quickly from the nozzle. Note: As expansion ratio is increased, the reach of the nozzle will be decreased due to the greater amount of bubbles in the stream and their inability to penetrate the air. Generally the reach with foam is approximately 10% less than with water only. Actual results will vary based on brand of foam, hardness of water, temperature, etc. See Foamjet instruction manual for specific information.

5.0 USE OF METRO NOZZLES

IT IS THE RESPONSIBILITY OF THE INDIVIDUAL FIRE DEPARTMENT OR AGENCY TO DETERMINE PHYSICAL CAPABILITIES AND SUITABILITY FOR AN INDIVIDUAL'S USE OF THIS EQUIPMENT.

Many factors contribute to the extinguishment of a fire. Among the most important is delivering water at a flow rate sufficient to absorb heat faster than it is being generated. The flow rate depends largely on the pump discharge pressure and hose friction loss. The pump discharge pressure may be found by use of the chart in section 10.0. It can also be calculated using a hydraulic equation such as:

For additional information on calculating specific hose layouts, consult an appropriate fire service training manual, such as IFSTA, or A Guide to Automatic Nozzles, or call TFT's "Hydraulics Hotline" at 800-348-2686.

See www.tft.com for flow rates at various pump pressures.

$$PDP = NP + FL + DL + EL$$

PDP = Pump discharge pressure in PSI

NP = Nozzle pressure in PSI

FL = Hose friction loss in PSI

DL = Device loss in PSI

EL = Elevation loss in PSI

6.0 FIELD INSPECTION

TFT's Metro is designed and manufactured to be damage resistant and require minimal maintenance. However, as the primary fire fighting tools upon which your life depends, they should be treated accordingly.

Use with saltwater is permissible provided nozzle is thoroughly cleaned with fresh water after each use. The service life of the nozzle may be shortened due to the effects of corrosion and is not covered under warranty.



WARNING Nozzle must be inspected for proper operation and function according to inspection checklist on last page before each use. Any nozzle that fails inspection is dangerous to use and must be repaired before using.

Performance tests shall be conducted on the Metro nozzle after a repair, or anytime a problem is reported to verify operation in accordance with TFT test procedures. Consult factory for the procedure that corresponds to the model and serial number of the nozzle. Any equipment which fails the related test criteria should be removed from service immediately. Troubleshooting guides are available with each test procedure or equipment can be returned to the factory for service and testing.

Factory service is available with repair time seldom exceeding one day in our facility. Factory serviced nozzles are repaired by experienced technicians to original specifications, fully tested and promptly returned. Any returns should include a note as to the nature of the problem, who to reach in case of questions and if a repair estimate is required.



CAUTION Any alterations to the nozzle and its markings could diminish safety and constitutes a misuse of this product.

All Task Force Tip nozzles are factory lubricated with high quality silicone grease. This lubricant has excellent washout resistance and long term performance. If your department has unusually hard or sandy water, the moving parts may be affected. Foam agents and water additives contain soaps and chemicals that may break down the factory lubrication.

The moving parts of the nozzle should be checked on a regular basis for smooth and free operation, and signs of damage. **IF THE NOZZLE IS OPERATING CORRECTLY, THEN NO ADDITIONAL LUBRICATION IS NEEDED.** Any nozzle that is not operating correctly should be immediately removed from service and the problem corrected.

7.0 REPAIR

Factory service is available with repair time seldom exceeding one day in our facility. Factory-serviced nozzles are repaired by experienced technicians to original specifications, fully wet tested, and promptly returned. Repair charges for non-warranty items are minimal. Any returns should include a note as to the nature of the problem and whom to reach in case of questions.

Task Force Tips assumes no liability for damage to equipment or injury to personnel that is a result of user service.

Repair kits and repair parts are stocked for immediate shipment. Contact the factory or visit the website at www.tft.com for parts lists, exploded views, test procedures and trouble shooting guides.

8.0 ANSWERS TO YOUR QUESTIONS

We appreciate the opportunity of serving you and making your job easier. If you have any problems or questions, our toll-free "Hydraulics Hotline", 800-348-2686, is normally available to you 24 hours a day, 7 days a week.

9.0 METRO 1 DRAWING AND PARTS LIST

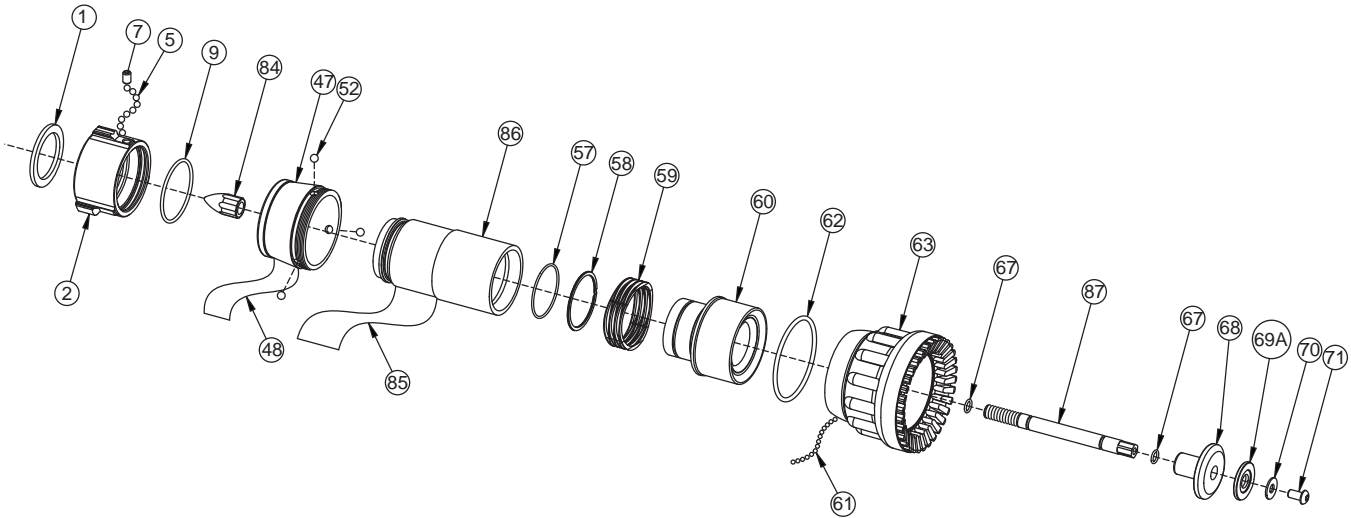

METRO 1 TIP ONLY

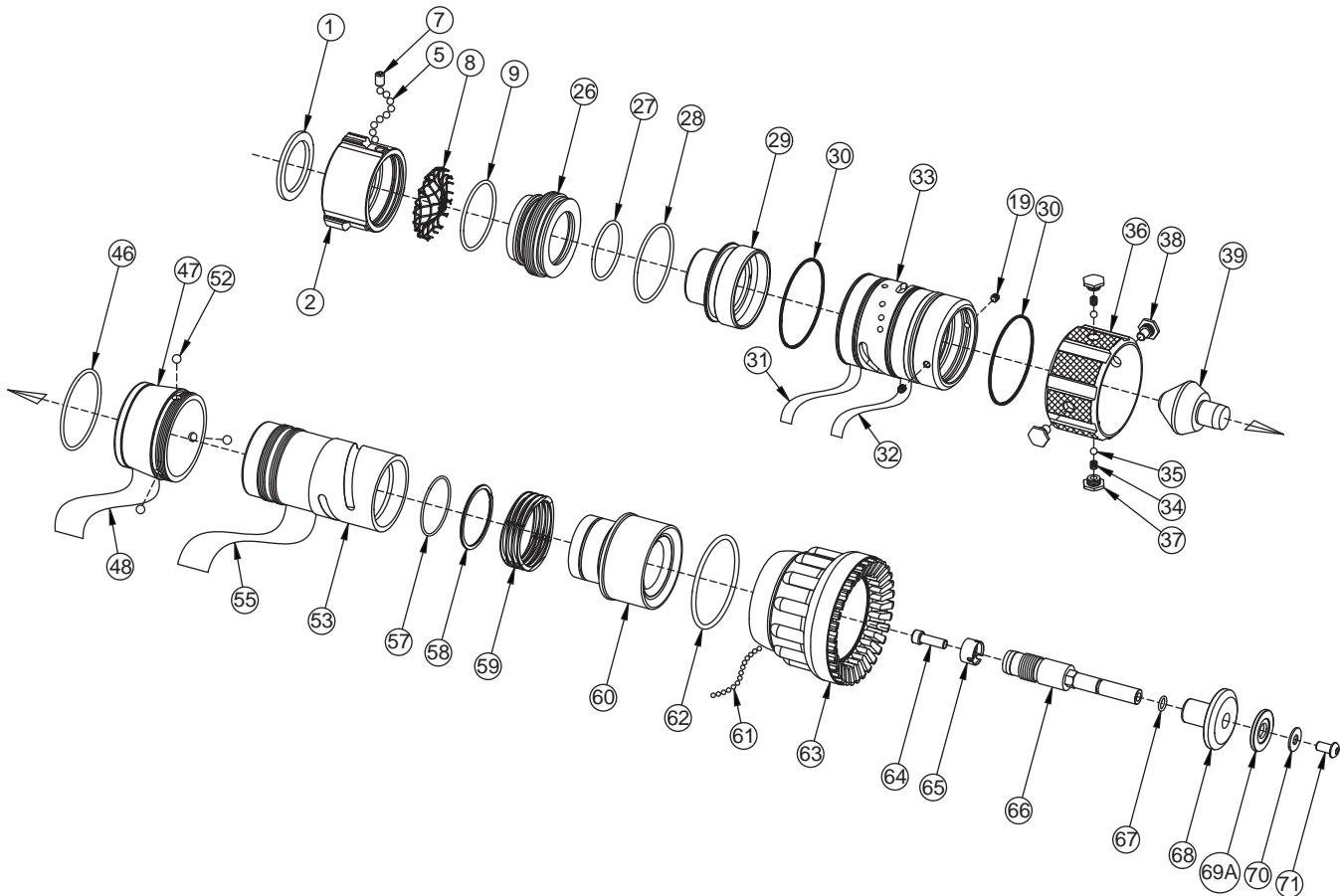

METRO 1 - STO

9.0 METRO 1 DRAWING AND PARTS LIST

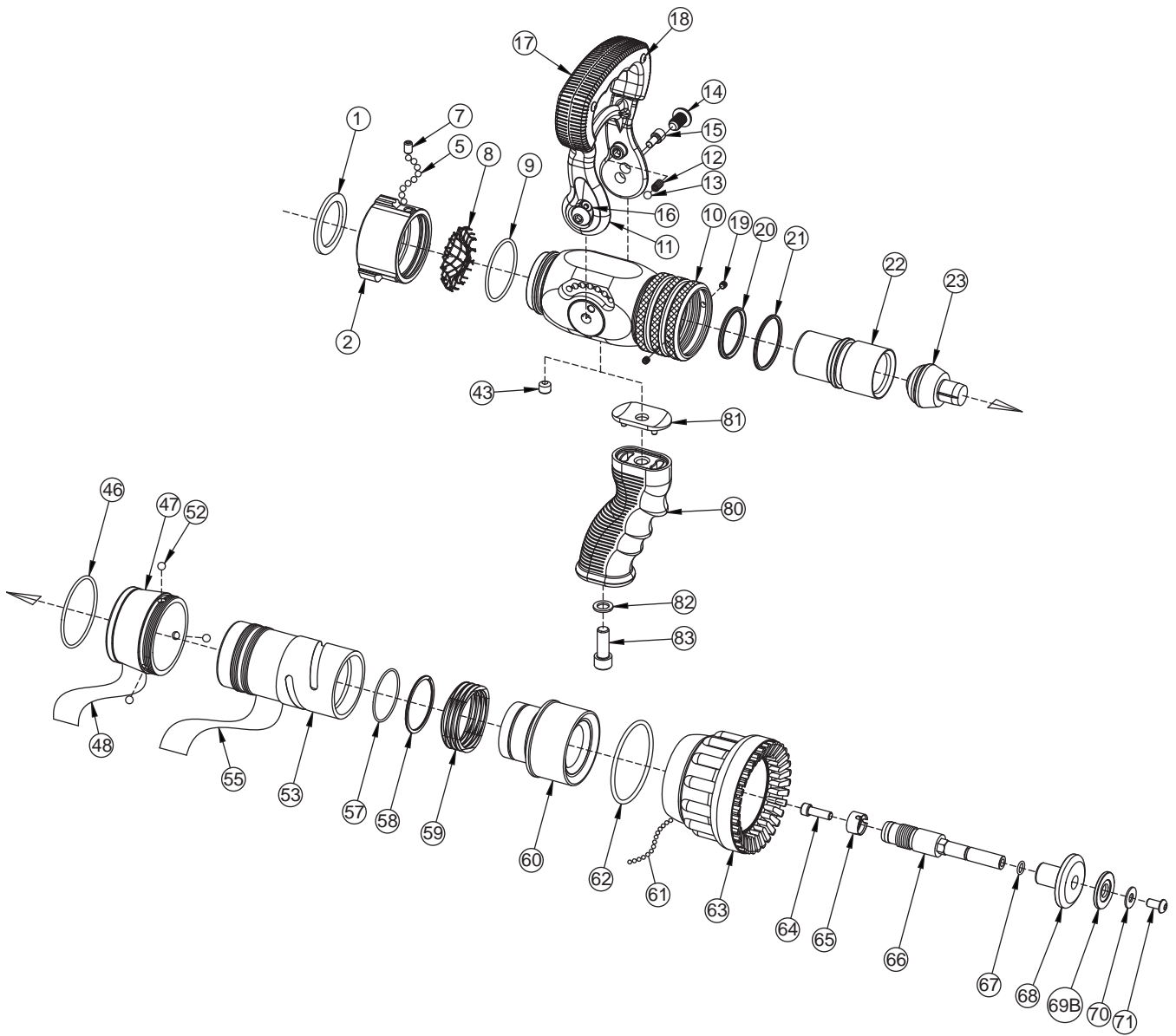

METRO 1 V AND VPGI

9.0 METRO 1 DRAWING AND PARTS LIST

#	DESCRIPTION	QTY	PART #
1	GASKET - 1.5"	1	V3130
2	COUPLING 1.5"NH	1	HM697*
5	3/16" TORLON BALL	33	V2120
7	1/4-28 X 3/16 SOCKET SET SCREW (SWIVEL)	1	VT25-28SS187
	1/4-28 X 3/8 SOCKET SET SCREW (LOCKOUT)		VT25-28SS375
8	1.5" GASKET GRABBER	1	HM730
9	O-RING-134	1	VO-134
10	VALVE BODY	1	HM600
	VALVE DISK	2	HM640
	DRAG NUB	4	HM650
	SMALLEY RING	2	V4270
11	HANDLE	1	HM622
12	DETENT SPRING	2	HM770
13	.243" TORLON BALL	2	VB243TO
14	HANDLE SCREW	2	HM645
15	CAM PIN	1	HM630
16	SAFETY PIN	1	HM635
17	BLACK HANDLE COVER	2	HM625-BLK
18	8-14 X 3/8 PUSHTITE BUTTON HEAD	4	VT08-14PT375
19	10-32 X 3/16 SOCKET SET SCREW	2	VT10Y32SS187
20	QUAD-RING-221	1	VOQ-4221
21	QUAD-RING-130	1	VOQ-4130
22	SLIDER	1	HM660
23	VALVE PLUG	1	HM590
26	STO TAIL PIECE	1	HM662
27	O-RING-129	1	VO-129
28	O-RING-138	1	VO-138
29	STO SLIDER	1	HM661
30	QUAD-RING-037	2	VOQ-4037
31	STO LABEL; VALVE OFF RED	1	HD755
32	STO LABEL; VALVE ON BLUE	1	HD750
33	STO BASE	1	HM655
34	STO DETENT SPRING	2	VM4200
35	3/16" TORLON BALL	2	V2120-TORLON
36	STO SLEEVE	1	HM668
37	DETENT SCREW	2	HD785
38	CAM SCREW	2	HD780
39	S.T.O. VALVE PLUG	1	HM592
43	3/8-16 X 5/16 SOCKET SET SCREW	1	VT37-16SS312

#	DESCRIPTION	QTY	PART #
46	O-RING-139	1	VO-139
47	SHAPER GUIDE	1	HMD510
48	NAME LABEL: METRO 1 - ORANGE	1	HM745-ORG
52	.243" TORLON BALL	3	VB243TO
53	BARREL	1	HM345
55	BARREL LABEL - ORANGE	1	HM740-ORG
57	O-RING-030	1	VO-030
58	SMALLEY RING	1	VR4230
59	FLUSH WAVE SPRING	1	HM785
60	BARREL CONE	1	HM520
61	1/8" NYLON BALL	64	V2135
62	O-RING-230	1	VO-230
63	SHAPER WITH BUMPER	1	HM500
64	1/4-28 X 3/4 SOCKET HEAD SCREW	1	VT25-28SH750
65	LOCKING SLEEVE	1	HM571
66	SHAFT	1	HM470
67	O-RING-011	2	VO-011
68	BAFFLE	1	HM461
69A	FLOW WASHER K=6.9 OR 6.0	1	HM33006
	FLOW WASHER K=17.7 OR 13.4		HM33013
	FLOW WASHER K=12.5 OR 9.5		HM33014
	FLOW WASHER K=15.0 OR 14.4		HM33015
	FLOW WASHER K=17.5 OR 17.3		HM33017
	FLOW WASHER K=26.2 OR 20.2		HM33021
69B	FLOW WASHER K=23.1 OR 21.2	1	HM33023
	FLOW WASHER K=12.5 OR 9.5		HM410-14
	FLOW WASHER K=15.0 OR 14.4		HM410-15
	FLOW WASHER K=17.5 OR 17.3		HM410-17
	FLOW WASHER K=26.2 OR 20.2		HM410-21
FLOW WASHER K=23.1 OR 21.2	HM410-23		
70	FLAT WASHER 1/4" STAINLESS	1	VV687E259-50
71	1/4-28 X 1/2 BUTTON HEAD SCREW	1	VT25-28BH500
80	PISTOL GRIP	1	HM692-BLK
81	GRIP SPACER MIDMATIC	1	HM693-HM
82	WASHER	1	VM4901
83	3/8-16 X 1 SOCKET HEAD SCREW	1	VT37-16SH1.0
84	CAP NUT	1	HM320
85	BARREL LABEL - ORANGE	1	HM741-ORG
86	BARREL	1	HM345
87	SHAFT	1	HM370

* - SPECIFY THREAD

10.0 METRO 2 DRAWING AND PARTS LIST

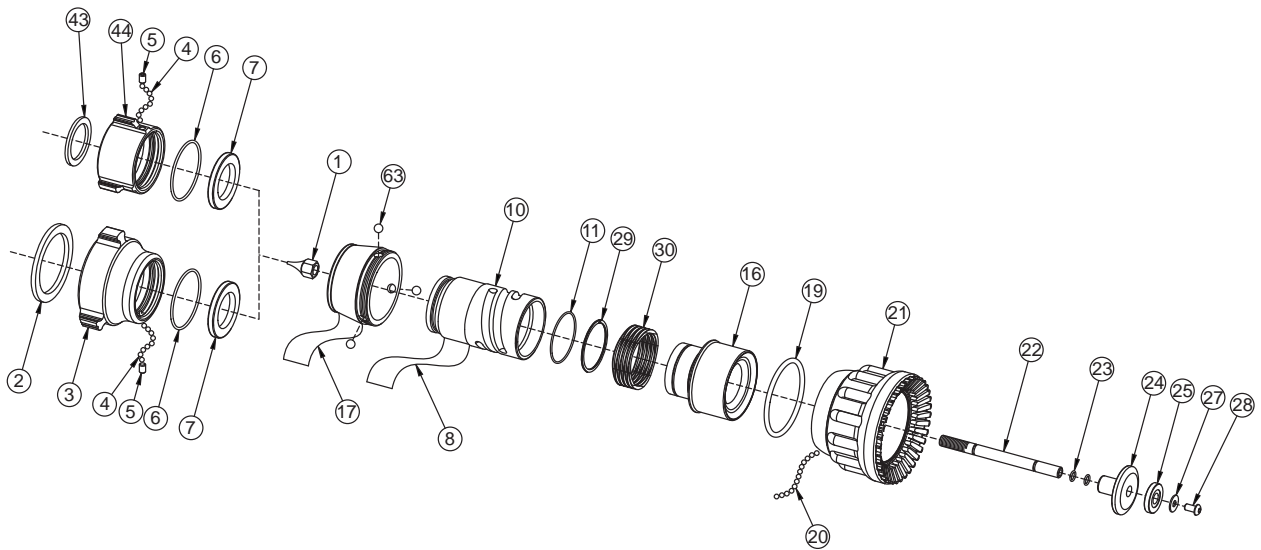

METRO 2 - TIP ONLY

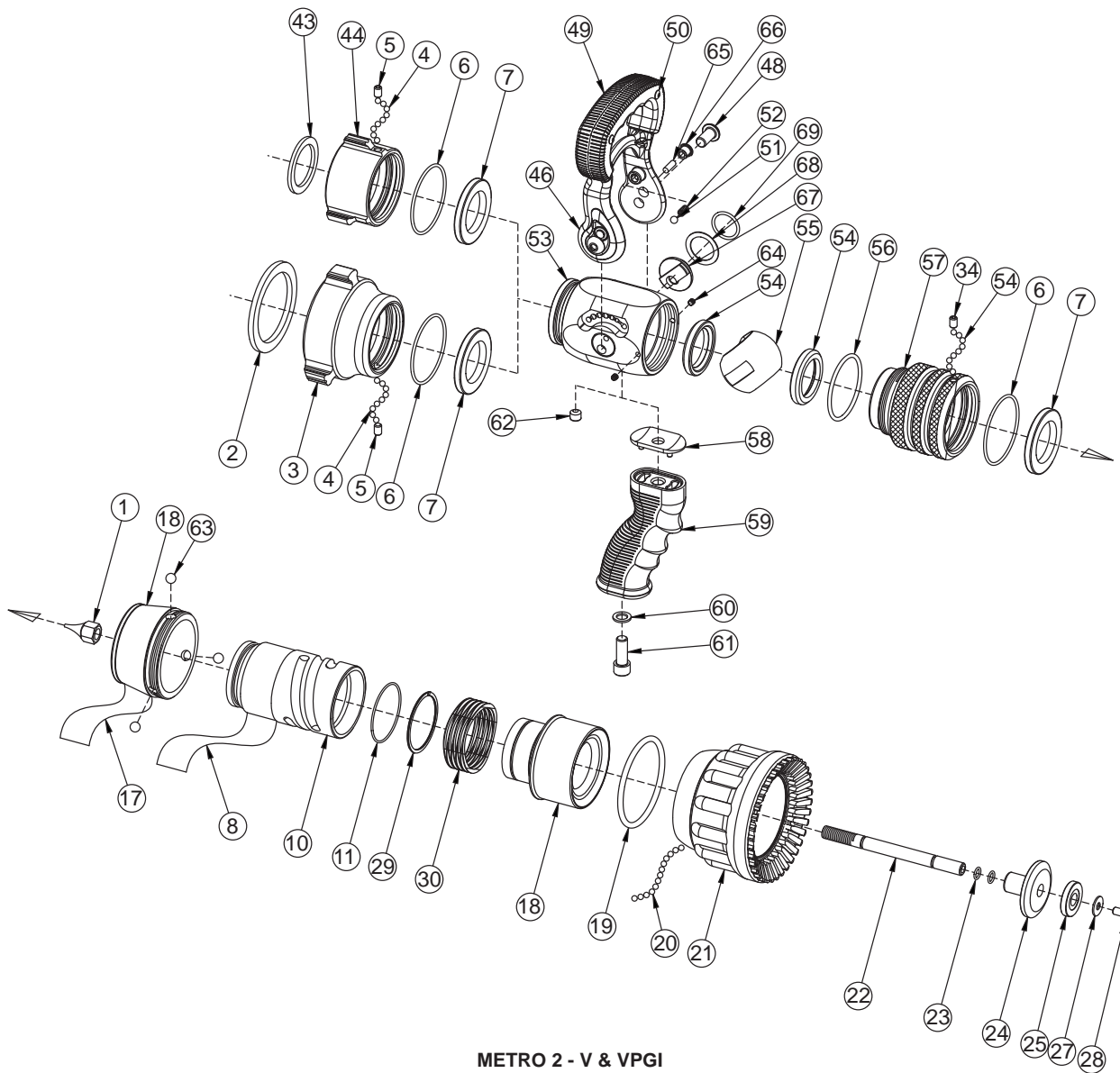

METRO 2 - V & VPGI

10.0 METRO 2 DRAWING AND PARTS LIST

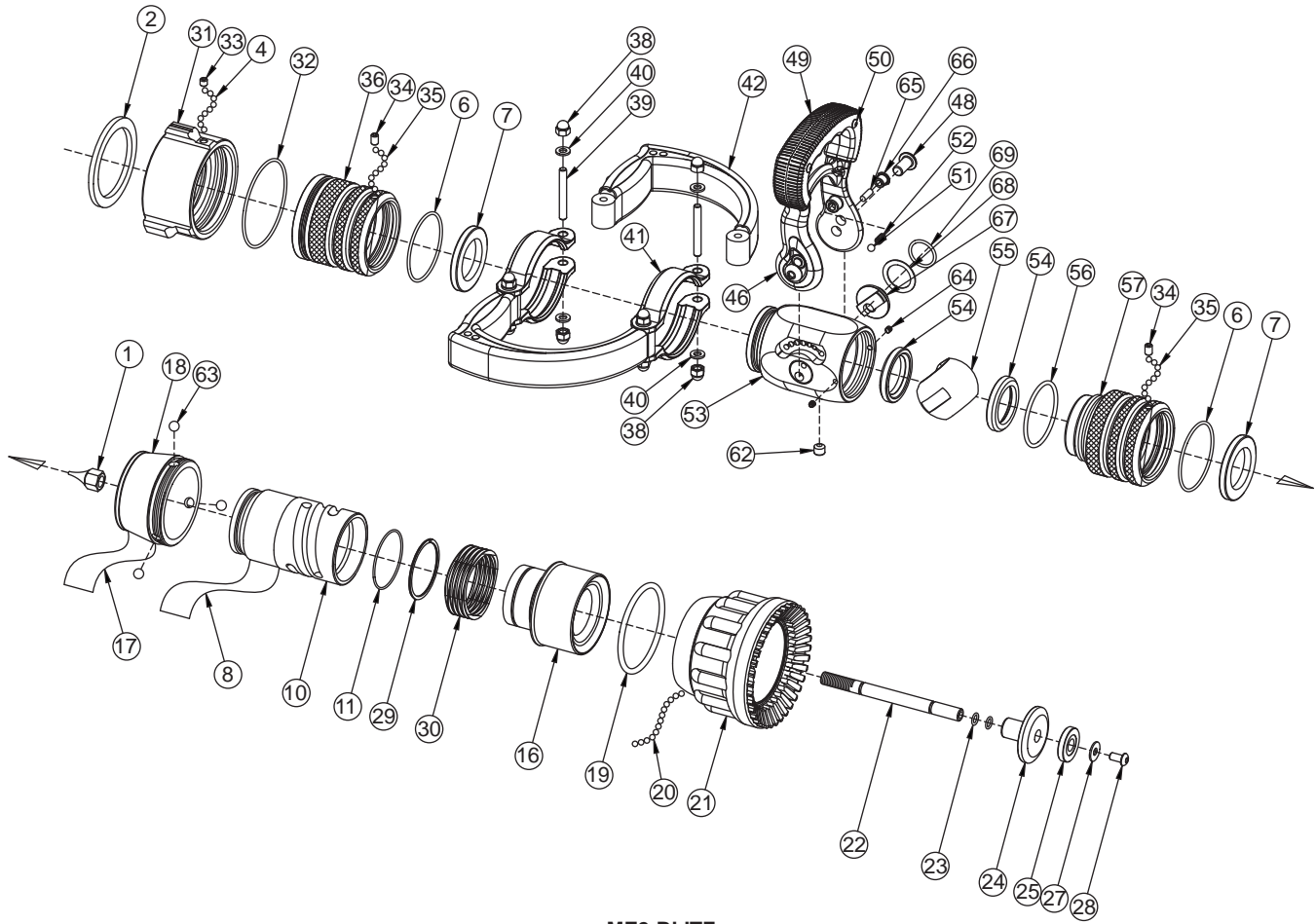

ME2-BLITZ

10.0 METRO 2 DRAWING AND PARTS LIST

#	DESCRIPTION	QTY	PART #
1	CAP NUT	1	H420
2	GASKET - 2.5"	1	V3190
3	COUPLING 2.5"NH ROCKERLUG	1	P198N
	COUPLING 2.5"NPSH ROCKERLUG		P198I
4	3/16" SS BALL	48	V2120
5	1/4-28 X 3/16 SOCKET SET SCREW (SWIVEL)	1	VT25-28SS187
	1/4-28 X 3/8 SOCKET SET SCREW (LOCK-OUT)		VT25-28SS375
6	O-RING-141	2	VO-141
7	ANTI GG RING VO	2	P147
8	BARREL LABEL - ORANGE	1	H740-ORG
10	BARREL	1	HX440
11	VO-RING-033	1	VO-033
16	BARREL CONE	1	HX520
17	NAME LABEL - METRO 2 - ORANGE	1	H745-ORG
18	SHAPER GUIDE	1	HXD510
19	O-RING-336	1	VO-336
20	3/16" ACETAL BALL	48	V2115
21	SHAPER WITH BUMPER	1	H500
22	SHAFT	1	HX470
23	VO-RING-011	2	VO-011
24	BAFFLE	1	H461
25	FLOW WASHER K=17.0 OR K=14.4	1	HX410-16
	FLOW WASHER K=23.1 OR K=21.3		HX410-22
	FLOW WASHER K=28.9 OR K=25.0		HX410-26
	FLOW WASHER K=35.4 OR K=32.5		HX410-34
27	FLAT WASHER 1/4" STAINLESS	1	VW687E259-50
28	1/4-28 X 1/2 BUTTON HEAD SCREW	1	VT25-28BH500
29	SMALLEY RING	1	VR4270
30	FLUSH WAVE SPRING	1	HX785
31	COUPLING ROCKERLUG	1	P197*
32	O-RING-151	1	VO-151
33	1/4-28 X 1/4 SOCKET SET SCREW	1	VT25-28SS250
34	1/4-28 X 3/8 SOCKET SET SCREW	1	VT25-28SS375
35	3/16" SS BALL	75	V2120
36	BLITZ BASE 2.5"	1	H675

#	DESCRIPTION	QTY	PART #
38	1/4-20 SS ACORN NUT	8	VT25E20AC
39	1/4-20 X 2 STUD FULL THREAD	4	VT25-20ST2.0
40	WASHER	8	VW500X265-63
41	BLITZ BRACKET	4	H676
42	PLAYPIPE HANDLE	2	P220
43	GASKET - 1.5"	1	V3130
44	COUPLING ROCKERLUG	1	H694*
46	HANDLE	1	HX620
48	3/8-24 X 3/4 BUTTON HEAD SCREW	2	VT37E24BH750
49	BLACK HANDLE COVER	2	HM625-BLK
50	8-14 X 3/8 PUSHTITE BUTTON HEAD	4	VT08-14PT375
51	.243" TORLON BALL	2	VB243TO
52	DETENT SPRING	2	HM770
53	DETENT VALVE BODY	1	P110
	VALVE LABEL - BLUE	1	H750
54	BALL SEAT VALVE	2	P104
55	DELTRIN VALVE BALL	1	P103
56	O-RING-227	1	VO-227
57	PLAYPIPE ADAPTER	1	HX450
58	GRIP SPACER HANDLINE	1	HM693-H
59	PISTOL GRIP - BLACK	1	HM692-BLK
60	WASHER	1	VM4901
61	3/8-16 X 1 SOCKET HEAD SCREW	1	VT37-16SH1.0
62	3/8-16 X 5/16 SOCKET SET SCREW	1	VT37-16SS312
63	.344" TORLON BALL	3	VB344TO
64	10-32 X 3/16 SOCKET SET SCREW	2	VT10Y32SS187
65	3/16 X 9/16 HDP SPIROL	2	V2005
66	TRUNNION DRIVER	2	HX650
67	TRUNNION - LEFT	1	P120L
	TRUNNION - RIGHT	1	P120R
68	TEFLON TRUNNION SHIM	2	P170
69	O-RING-118	2	VO-118
* - SPECIFY THREAD			

11.0 INSPECTION CHECKLIST

Nozzle must be inspected for proper operation and function according to this checklist before each use.

Check that:

- 1) There is no obvious damage such as missing, broken or loose parts, damaged labels, etc.
- 2) Coupling is tight and leak free
- 3) Valve handle moves freely through full range and shuts off flow
- 4) Nozzle flow is adequate as indicated by pump pressure and nozzle reaction
- 5) Shaper turns freely and adjusts pattern through full range
- 6) Nozzle moves smoothly in and out of flush position

▲ WARNING

Any nozzle failing any part of the inspection checklist is unsafe and must have the problem corrected before use. Operating a nozzle that fails any of the above inspections is a misuse of this equipment.

12.0 WARRANTY

Task Force Tips, Inc., 3701 Innovation Way, Valparaiso, Indiana 46383-9327 USA ("TFT") warrants to the original purchaser of its Metro series nozzles ("equipment"), and to anyone to whom it is transferred, that the equipment shall be free from defects in material and workmanship during the five (5) year period from the date of purchase.

TFT's obligation under this warranty is specifically limited to replacing or repairing the equipment (or its parts) which are shown by TFT's examination to be in a defective condition attributable to TFT. To qualify for this limited warranty, the claimant must return the equipment to TFT, at 3701 Innovation Way, Valparaiso, Indiana 46383-9327 USA, within a reasonable time after discovery of the defect. TFT will examine the equipment. If TFT determines that there is a defect attributable to it, TFT will correct the problem within a reasonable time. If the equipment is covered by this limited warranty, TFT will assume the expenses of repair.

If any defect attributable to TFT under this limited warranty cannot be reasonably cured by repair or replacement, TFT may elect to refund the purchase price of the equipment, less reasonable depreciation, in complete discharge of its obligations under this limited warranty. If TFT makes this election, claimant shall return the equipment to TFT free and clear of any liens and encumbrances.

This is a limited warranty. The original purchaser of the equipment, any person to whom it is transferred, and any person who is an intended or unintended beneficiary of the equipment, shall not be entitled to recover from TFT any consequential or incidental damages for injury to person and/or property resulting from any defective equipment manufactured or assembled by TFT. It is agreed and understood that the price stated for the equipment is in part consideration for limiting TFT's liability. Some states do not allow the exclusion or limitation of incidental or consequential damages, so the above may not apply to you.

TFT shall have no obligation under this limited warranty if the equipment is, or has been, misused or neglected (including failure to provide reasonable maintenance) or if there have been accidents to the equipment or if it has been repaired or altered by someone else.

THIS IS A LIMITED EXPRESS WARRANTY ONLY. TFT EXPRESSLY DISCLAIMS WITH RESPECT TO THE EQUIPMENT ALL IMPLIED WARRANTIES OF MERCHANTABILITY AND ALL IMPLIED WARRANTIES OF FITNESS FOR A PARTICULAR PURPOSE. THERE IS NO WARRANTY OF ANY NATURE MADE BY TFT BEYOND THAT STATED IN THIS DOCUMENT.

This limited warranty gives you specific legal rights, and you may also have other rights which vary from state to state.

TASK FORCE TIPS, INC.
MADE IN USA • www.tft.com

3701 Innovation Way, Valparaiso, IN 46383-9327 USA
800-348-2686 • 219- 462-6161 • Fax 219-464-7155