



MANUAL: Metro 1 & 2 Fixed Gallonage Nozzle

INSTRUCTIONS FOR SAFE OPERATION AND MAINTENANCE

⚠ WARNING

Read instruction manual before use. Operation of this nozzle without understanding the manual and receiving proper training can be dangerous and is a misuse of this equipment. Call 800-348-2686 with any questions.

⚠ WARNING

This instruction manual is intended to familiarize firefighters and maintenance personnel with the operation, servicing and safety procedures associated with the Metro 1 and Metro 2 fire fighting nozzles.

⚠ WARNING

This manual should be kept available to all operating and maintenance personnel.

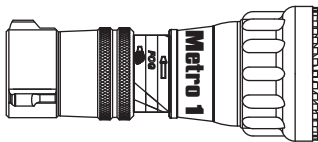

ME1-STO

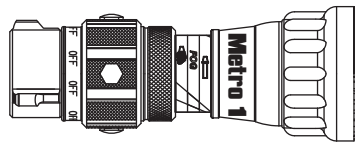

ME1-TO

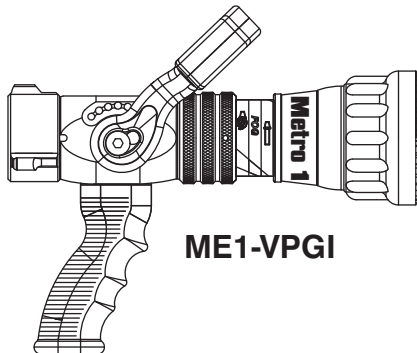

ME1-VPGI

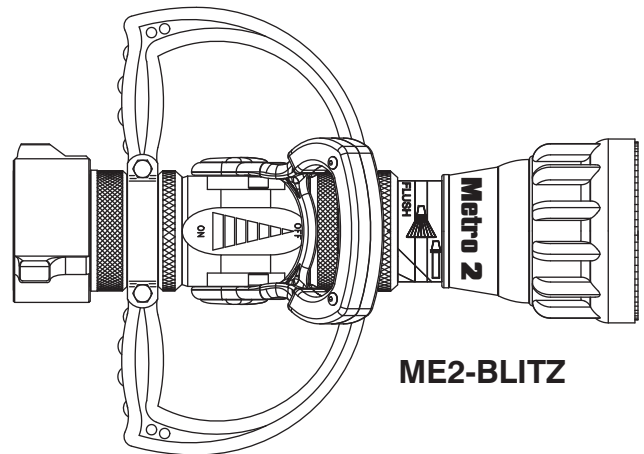

ME2-BLITZ

⚠ DANGER

PERSONAL RESPONSIBILITY CODE



Fire and Emergency Manufacturers and Services Association, Inc.
P.O. Box 147, Lynnfield, MA 01940 • www.FEMSA.org

The member companies of FEMSA that provide emergency response equipment and services want responders to know and understand the following:

1. Firefighting and Emergency Response are inherently dangerous activities requiring proper training in their hazards and the use of extreme caution at all times.
2. It is your responsibility to read and understand any user's instructions, including purpose and limitations, provided with any piece of equipment you may be called upon to use.
3. It is your responsibility to know that you have been properly trained in Firefighting and /or Emergency Response and in the use, precautions, and care of any equipment you may be called upon to use.
4. It is your responsibility to be in proper physical condition and to maintain the personal skill level required to operate any equipment you may be called upon to use.
5. It is your responsibility to know that your equipment is in operable condition and has been maintained in accordance with the manufacturer's instructions.
6. Failure to follow these guidelines may result in death, burns or other severe injury.

TASK FORCE TIPS, Inc.
Made in USA • www.tft.com

3701 Innovation Way • Valparaiso, IN 46383-9327 USA
800-348-2686 • 219-462-6161 • Fax 219-464-7155

TABLE OF CONTENTS

1.0	MEANING OF SAFETY SIGNAL WORDS	4.3	PATTERN CONTROL
2.0	GENERAL INFORMATION	4.4	FLUSH CONTROL
2.1	VARIOUS MODELS AND TERMS	4.5	USE WITH FOAM
2.2	NOZZLE COUPLINGS	4.5.1	FOAM ASPIRATING ATTACHMENTS
3.0	FLOW CHARACTERISTICS	5.0	USE OF METRO NOZZLES
3.1	FLOW SETTING	6.0	FIELD INSPECTION
3.2	WASHER SETTING	7.0	REPAIR
4.0	NOZZLE CONTROLS	8.0	ANSWERS TO YOUR QUESTIONS
4.1	FLOW CONTROL	9.0	METRO 1 DRAWINGS AND PARTS LIST
4.1.1	LEVER TYPE FLOW CONTROL	10.0	METRO 2 DRAWINGS AND PARTS LIST
4.1.2	TWIST SHUTOFF	11.0	INSPECTION CHECKLIST
4.1.3	TIP ONLY NOZZLES	12.0	WARRANTY
4.2	BALL SHUTOFF		

1.0 MEANING OF SAFETY SIGNAL WORDS

A safety related message is identified by a safety alert symbol and a signal word to indicate the level of risk involved with a particular hazard. Per ANSI standard Z535.4-1998 the definitions of the three signal words are as follows:



DANGER indicates an imminently hazardous situation which, if not avoided, will result in death or serious injury.



WARNING indicates a potentially hazardous situation which, if not avoided, could result in death or serious injury.



CAUTION indicates a potentially hazardous situation which, if not avoided, may result in minor or moderate injury.

2.0 GENERAL INFORMATION

The Task Force Tips Metro nozzles are designed to provide excellent performance under most fire fighting conditions. Their rugged construction is compatible with the use of fresh water (see section 6.0 for saltwater use) as well as fire fighting foam solutions. Other important operating features are: Interchangeable washer to allow for user defined flow and pressure; Quick-acting pattern control from straight stream to wide fog; "Power fog teeth" for full-fill fog; Easily flushable while flowing to clear trapped debris; TFT's five-year warranty and unsurpassed customer service.



This equipment is intended for use by trained personnel for firefighting. Their use for other purposes may involve hazards not addressed by this manual. Seek appropriate guidance and training to reduce risk of injury.



Nozzle reaction will vary as supply conditions change: such as opening or closing other nozzles, hose line kinks, changes in pump settings, etc. Changes in spray pattern or flushing will also affect nozzle reaction. The nozzle operator must always be prepared in the event of those changes. Failure to restrain nozzle reaction can cause firefighter injury from loss of footing and/or stream protection.



If nozzle gets out of control or away from operator, retreat from nozzle immediately. Do not attempt to regain control of nozzle while flowing water. Injury from whipping can occur.



Water is a conductor of electricity. Application of water solutions on high voltage equipment can cause injury or death by electrocution. The amount of current that may be carried back to the nozzle will depend on the following factors: Voltage of the line or equipment; Distance from the nozzle to the line or equipment; Size of the stream; Whether the stream is solid or broken; Purity of the water¹



Fire streams are capable of injury and damage. Do not direct water stream to cause injury or damage to persons or property.

2.1 VARIOUS MODELS AND TERMS

Fixed Flow: A nozzle with a discharge orifice that is a fixed opening size.

Tip Only: a nozzle without an integral ball shutoff valve. A Metro tip only nozzle is available in a variety of flow ranges and configurations. All models deliver the rated flow when the rated pressure is supplied to the nozzle.

SERIES	RECOMMENDED HOSE SIZE (INCHES)	FLOW SETTINGS	NOZZLE TYPE
METRO 1 (small body)	1-1/2	Field Changeable To Any of 10 Sizes	Fixed Flow
METRO 2 (large body)	1-1/2 to 2-1/2	Field Changeable To Any of 8 Sizes	Fixed Flow

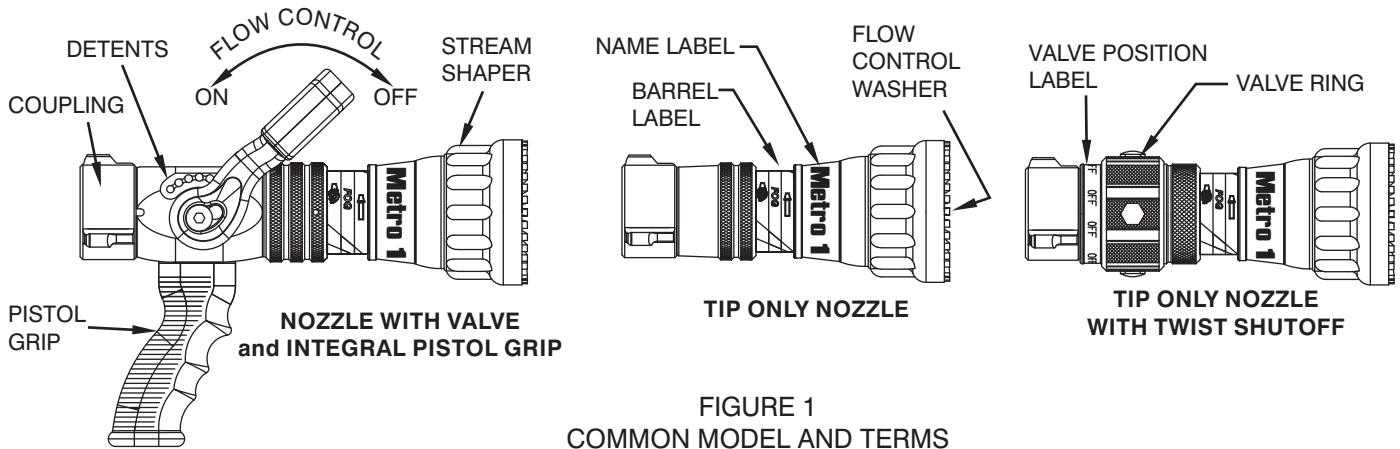

FIGURE 1
COMMON MODEL AND TERMS

2.2 NOZZLE COUPLING

NH (National Hose Threads per NFPA #1963) threads are standard on all nozzles. Other threads such as NPSH (National Pipe Straight Hose threads per ANSI/ASME #B1.20.7) can be specified at time of order.



Nozzle must be properly connected. Mismatched or damaged threads may cause nozzle to leak or uncouple under pressure and could cause injury.



Dissimilar metals coupled together can cause galvanic corrosion that can result in the inability to unscrew the threads of complete loss of thread engagement over time. Per NFPA 1962 (1998 edition), if dissimilar metals are left coupled together an anti-corrosive lubricant should be applied to the threads. Also the coupling should be disconnected and inspected at least quarterly.

3.0 FLOW CHARACTERISTICS

The opening size of the Metro nozzles may be field set to any one of the several different sizes. At each flow setting the nozzle is set to a predetermined fixed orifice. Relationship of flow and nozzle pressure at each setting is shown below.

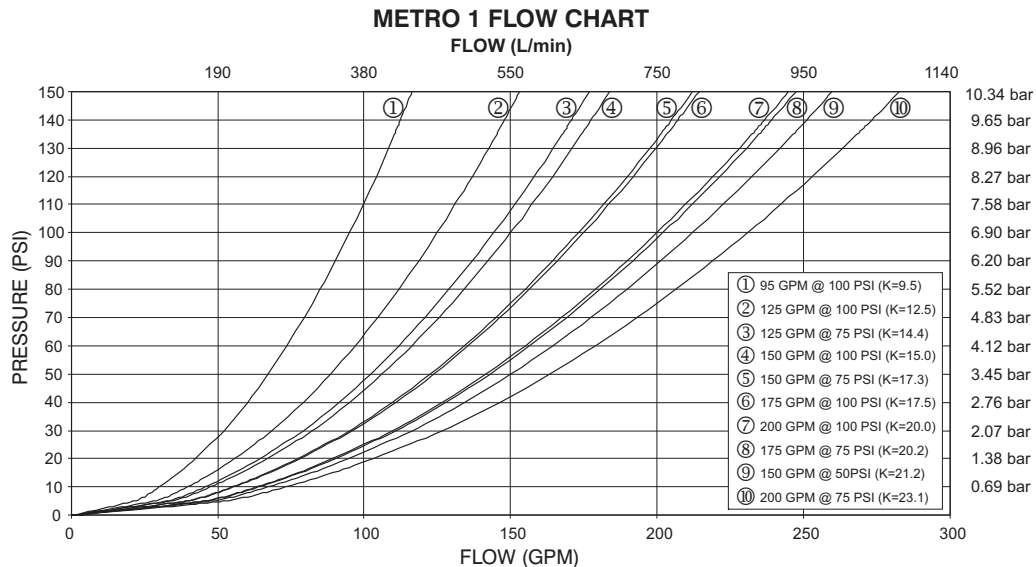

3.0 FLOW CHARACTERISTICS (continued)

METRO 1 FLOW VS REACTION FORCE

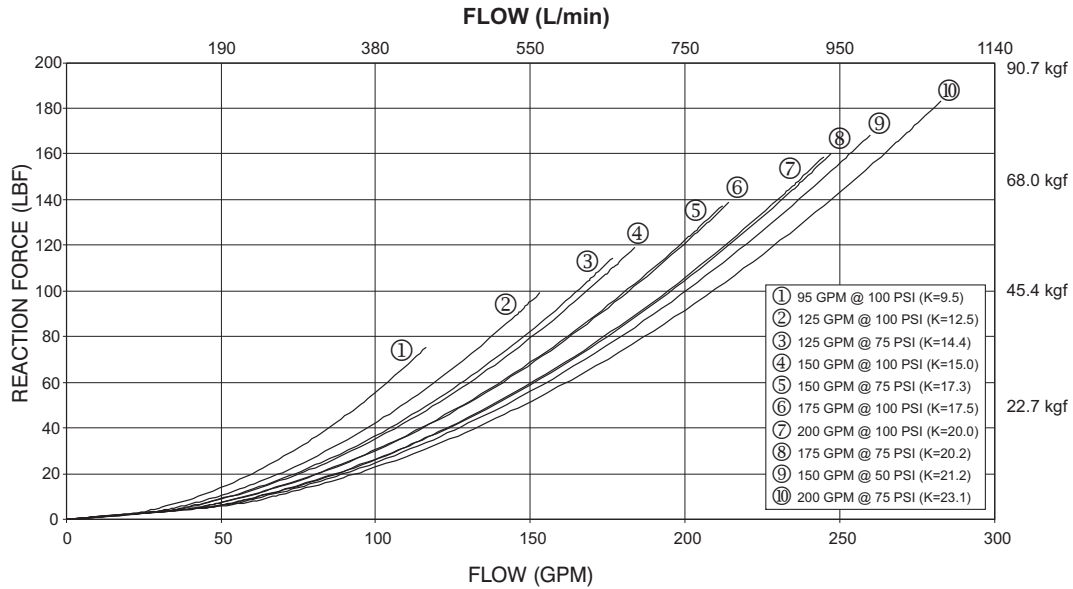

METRO 2 FLOW CHART

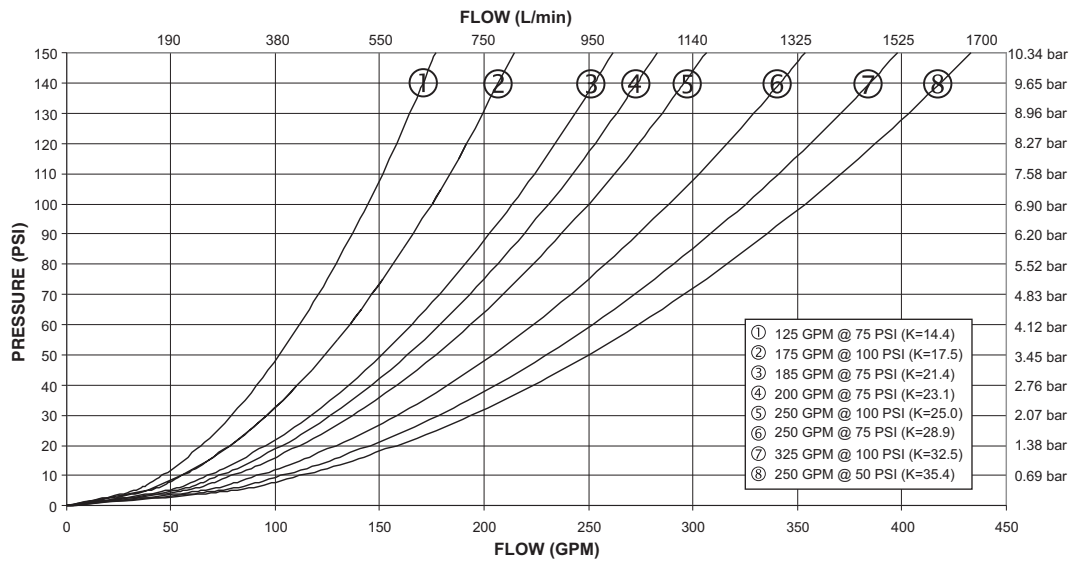

METRO 2 FLOW VS. REACTION FORCE

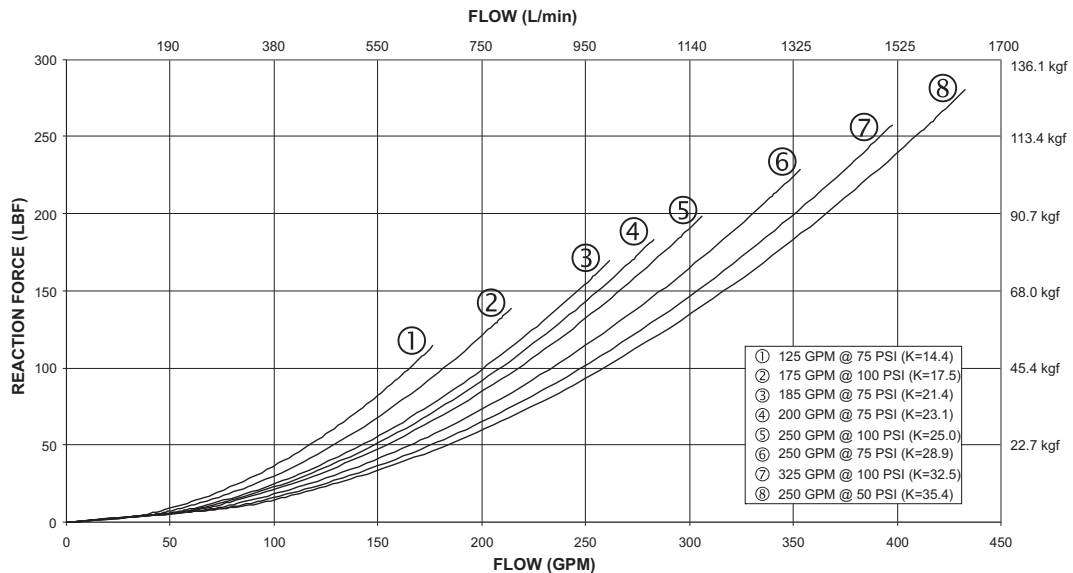

3.1 FLOW SETTING

The washers are marked with various flow settings. Change washer to the desired setting. **The nozzle will flow the indicated amount when the pressure at the nozzle is at the indicated level.**

3.2 WASHER SETTING

To change flow and pressure setting of the Metro, use the following instructions:

- 1) Set nozzle into FLUSH.
- 2) Push baffle down to barrel cone.
- 3) Remove screw and washer using a 5/32 hex key.
- 4) Remove pre-set flow washer and slide desired flow washer onto shaft, desired flow marking facing up.
- 5) Thread screw with washer back into shaft until snug (**Do not over tighten**).

NOTE: H410- are not compatible with new Metro 2 nozzles**

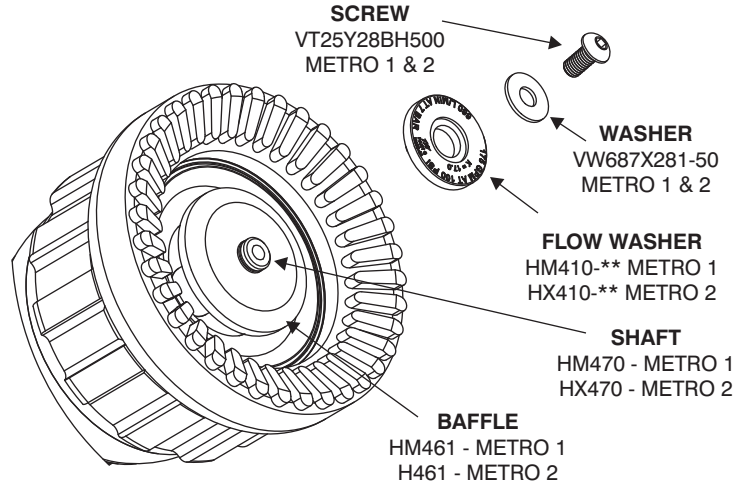

An inadequate supply of nozzle pressure and/or flow will cause an ineffective stream and can result in injury, death or loss of property. See flow charts in section 3.0 or call 800-348-2686 for assistance.



Failure to secure screw and washer will result in the baffle becoming loose. This will produce poor stream, improper flows and possible discharge of the complete baffle, resulting in risk of injury.



Failure to restrain nozzle reaction can cause firefighter injury from loss of footing and/or stream protection. Nozzle reaction will vary as supply conditions change: such as opening or closing other nozzles, hose line kinks, changes in pump settings, etc. Changes in spray pattern or flushing will also affect nozzle reaction. The nozzle operator must always be positioned to restrain the nozzle reaction in the event of those changes.



Injury from whipping can occur. If nozzle gets out of control or away from operator, retreat from nozzle immediately. Do not attempt to regain control of nozzle while flowing water.



Fire streams are capable of injury and damage. Do not direct water stream to cause injury or damage to persons or property.

4.0 NOZZLE CONTROLS

4.1 FLOW CONTROL

4.1.1 LEVER TYPE FLOW CONTROL

On models that use a lever type valve handle, the nozzle is shut off when the handle is fully forward. The valve handle has six detent flow positions. These detent positions allow the nozzle operator to regulate the flow of the nozzle depending on the need or what can be safely and effectively handled. TFT recommends the use of a pistol grip for easier handling. For additional stress reduction, a hose rope or strap may also be used. This permits more effective use and ease of advancement, while minimizing strain and fatigue.

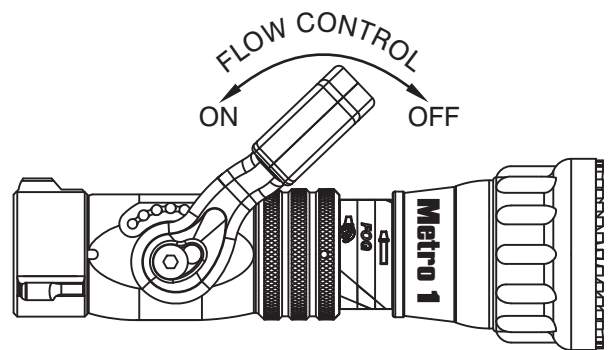

4.1.2 TWIST SHUTOFF

On models that use a twist flow control, the valve is opened or closed by rotating the valve ring. Rotating the ring clockwise (as seen from the operating position behind the nozzle) closes the valve, while counterclockwise rotation opens it. Detents are provided at four intermediate positions and the position of the valve is shown by the exposed valve position label.

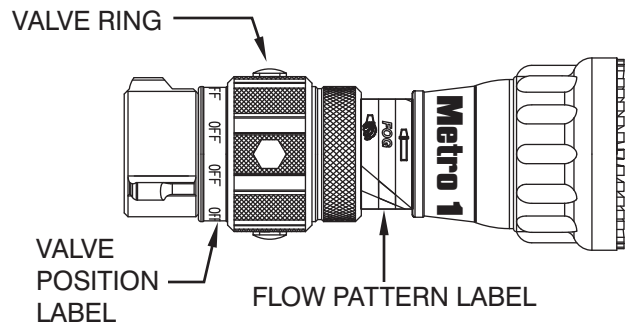

4.1.3 TIP ONLY NOZZLES

Tip only nozzles have NO shut off valve contained within the nozzle and **MUST** be used with a separate ball valve attached to the nozzle.

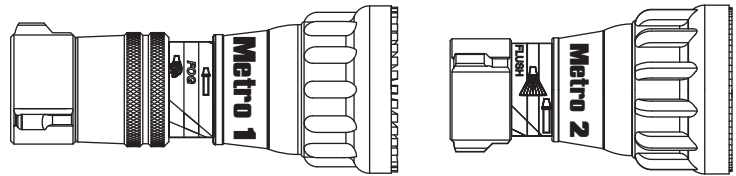

4.2 BALL VALVE SHUTOFF

Models with a ball valve are shut off when the valve handle is fully forward. Pulling back on the handle opens the valve. Open valve slowly to avoid sudden changes in nozzle reaction. Close valve slowly to prevent water hammer. Note: In partially open positions a ball valve will cause turbulence and adversely affect stream quality.

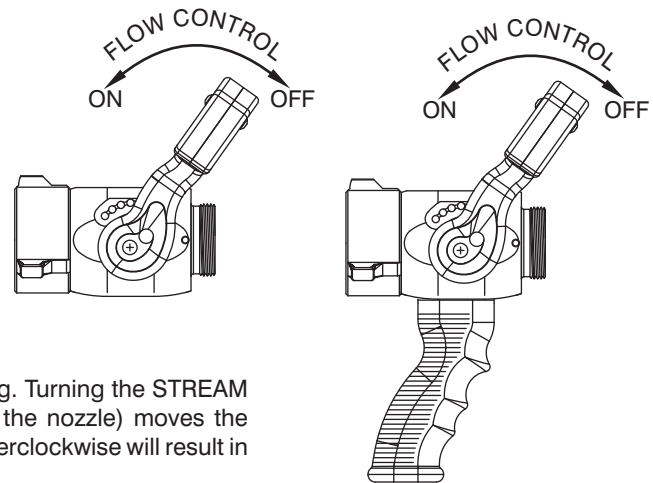

4.3 PATTERN CONTROL

TFT's Metro has full pattern control from straight stream to wide fog. Turning the STREAM SHAPER clockwise (as seen from the operating position behind the nozzle) moves the SHAPER to the straight stream position. Turning the SHAPER counterclockwise will result in an increasingly wider pattern.

Since the stream trim point varies with the flow, the stream should be "trimmed" after changing the flow to obtain the straightest and farthest reaching stream. To properly trim a stream, first open the pattern to a narrow fog. Then close the stream to parallel to give maximum reach. **NOTE: Turning the shaper further forward will cause stream crossover and reduce the effective reach of the nozzle.**

The nozzle reaction is greatest when the shaper is in the straight stream position. The nozzle operator must be prepared for a change in reaction as the pattern is changed.

4.4 FLUSH CONTROL

Small debris may get caught inside the nozzle. This trapped material will cause poor stream quality, shortened reach and reduced flow. To remove this trapped debris the nozzle can be flushed as follows; while still flowing water, turn the SHAPER counterclockwise past the full fog position (increased resistance will be felt on the SHAPER as the nozzle goes into flush). This will open the nozzle allowing debris to pass through. Rotate the SHAPER clockwise and out of flush to continue normal operation. During flush the nozzle reaction will decrease as the pattern becomes wider and the pressure drops. The nozzle operator must be prepared for an increase of nozzle reaction when returning the nozzle from the flush position to retain control of the nozzle.



Large amounts or pieces of debris may be unflushable and can reduce the flow of the nozzle resulting in an ineffective flow. In the event of a blockage, it may be necessary to retreat to a safe area, uncouple nozzle and remove debris.

4.5 USE WITH FOAM

The Metro nozzles may be used with foam solutions. Refer to fire service training for the proper use of foam.



For Class B fires, lack of foam or interruption in the foam stream can cause a break in the foam blanket and greatly increase the risk of injury or death. Assure that: Application rate is sufficient (see NFPA 11 or foam manufacturer's recommendations); Enough concentrate is on hand to complete task (see NFPA for minimum duration time requirements); Foam logistics have been carefully planned. Allow for such things as: Storage of foam in a location not exposed to the hazard it protects; Personnel, equipment and technique to deliver foam at a rapid enough rate; Removal of empty foam containers; Clear path to deliver foam, as hoses and other equipment and vehicles are deployed.



Improper use of foam can result in injury or damage to the environment. Follow foam manufacturer's instructions and fire service training to avoid: Using wrong type of foam on a fire, i.e. Class A foam on a Class B fire; Plunging foam into pools of burning liquid fuels; Causing environmental damage; Directing stream at personnel.



There is a wide variety of foam concentrates. Each user is responsible for verifying that any foam concentrate chosen to be used with this unit has been tested to assure that the foam obtained is suitable for the purpose intended.

4.5.1 FOAM ASPIRATING ATTACHMENTS

To increase the expansion ratio, Task Force Tips "MX Foamjet" (model FJ-MX-HM) multi expansion attachment or LX Foamjet (model FJ-LX-HM) low expansion attachment may be used with the Metro 1 nozzle and (model FJ-HMX) multi expansion attachment or LX Foamjet (model FJ-H) low expansion attachment may be used with the Metro 2 nozzle. These foam tubes attach and detach quickly from the nozzle. Note: As expansion ratio is increased, the reach of the nozzle will be decreased due to the greater amount of bubbles in the stream and their inability to penetrate the air. Generally the reach with foam is approximately 10% less than with water only. Actual results will vary based on brand of foam, hardness of water, temperature, etc. See Foamjet instruction manual for specific information.

5.0 USE OF METRO NOZZLES

IT IS THE RESPONSIBILITY OF THE INDIVIDUAL FIRE DEPARTMENT OR AGENCY TO DETERMINE PHYSICAL CAPABILITIES AND SUITABILITY FOR AN INDIVIDUAL'S USE OF THIS EQUIPMENT.

Many factors contribute to the extinguishment of a fire. Among the most important is delivering water at a flow rate sufficient to absorb heat faster than it is being generated. The flow rate depends largely on the pump discharge pressure and hose friction loss. It can be calculated using a hydraulic equation such as:

For additional information on calculating specific hose layouts, consult an appropriate fire service training manual, such as IFSTA, or *A Guide to Automatic Nozzles*, or call TFT's "Hydraulics Hotline" at 800-348-2686.

See www.tft.com for flow rates at various pump pressures.

$$PDP = NP + FL + DL + EL$$

PDP = Pump discharge pressure in PSI
NP = Nozzle pressure in PSI
FL = Hose friction loss in PSI
DL = Device loss in PSI
EL = Elevation loss in PSI

6.0 FIELD INSPECTION

TFT's Metro is designed and manufactured to be damage resistant and require minimal maintenance. However, as the primary fire fighting tools upon which your life depends, they should be treated accordingly.

Use with saltwater is permissible provided nozzle is thoroughly cleaned with fresh water after each use. The service life of the nozzle may be shortened due to the effects of corrosion and is not covered under warranty.



Nozzle must be inspected for proper operation and function according to inspection checklist on last page before each use. Any nozzle that fails inspection is dangerous to use and must be repaired before using.

Performance tests shall be conducted on the Metro nozzle after a repair, or anytime a problem is reported to verify operation in accordance with TFT test procedures. Consult factory for the procedure that corresponds to the model and serial number of the nozzle. Any equipment which fails the related test criteria should be removed from service immediately. Troubleshooting guides are available with each test procedure or equipment can be returned to the factory for service and testing.

Factory service is available with repair time seldom exceeding one day in our facility. Factory serviced nozzles are repaired by experienced technicians to original specifications, fully tested and promptly returned. Any returns should include a note as to the nature of the problem, who to reach in case of questions and if a repair estimate is required.



Any alterations to the nozzle and its markings could diminish safety and constitutes a misuse of this product.

All Task Force Tip nozzles are factory lubricated with high quality silicone grease. This lubricant has excellent washout resistance and long term performance. If your department has unusually hard or sandy water, the moving parts may be affected. Foam agents and water additives contain soaps and chemicals that may break down the factory lubrication.

The moving parts of the nozzle should be checked on a regular basis for smooth and free operation, and signs of damage. **IF THE NOZZLE IS OPERATING CORRECTLY, THEN NO ADDITIONAL LUBRICATION IS NEEDED.** Any nozzle that is not operating correctly should be immediately removed from service and the problem corrected.

7.0 REPAIR

Factory service is available with repair time seldom exceeding one day in our facility. Factory-serviced nozzles are repaired by experienced technicians to original specifications, fully wet tested, and promptly returned. Repair charges for non-warranty items are minimal. Any returns should include a note as to the nature of the problem and whom to reach in case of questions.

Task Force Tips assumes no liability for damage to equipment or injury to personnel that is a result of user service.

Repair kits and repair parts are stocked for immediate shipment. Contact the factory or visit the website at www.tft.com for parts lists, exploded views, test procedures and trouble shooting guides.

8.0 ANSWERS TO YOUR QUESTIONS

We appreciate the opportunity of serving you and making your job easier. If you have any problems or questions, our toll-free "Hydraulics Hotline", 800-348-2686, is normally available to you 24 hours a day, 7 days a week.

9.0 METRO 1 DRAWINGS & PART LIST

BACK END PARTS

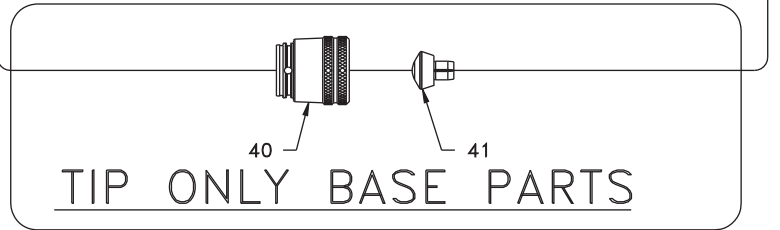
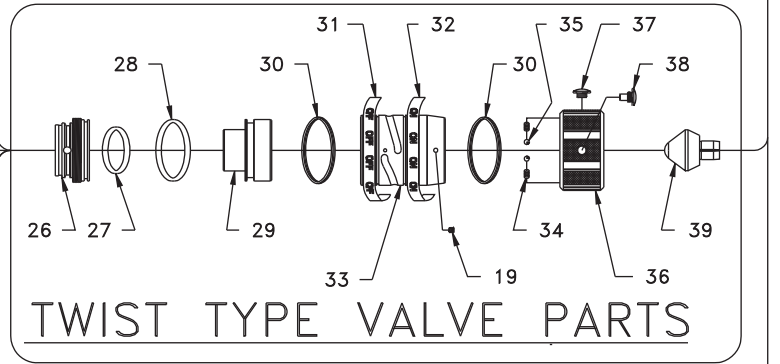
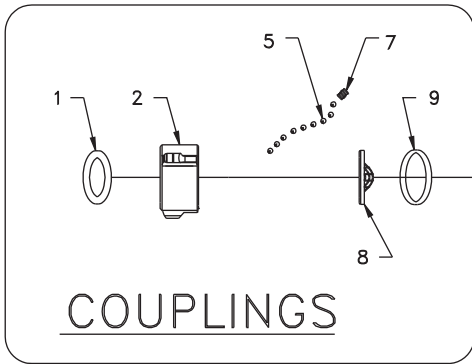
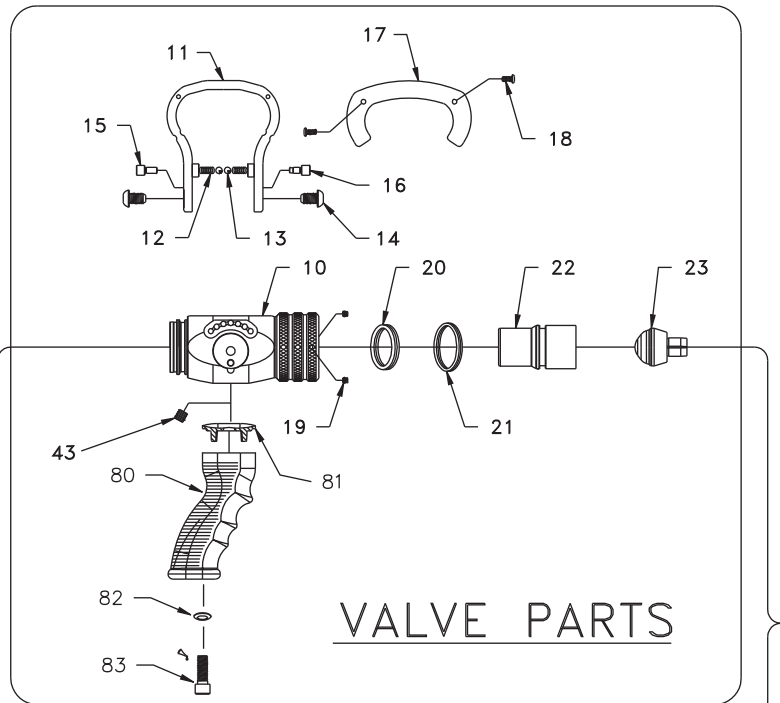

FRONT END PARTS

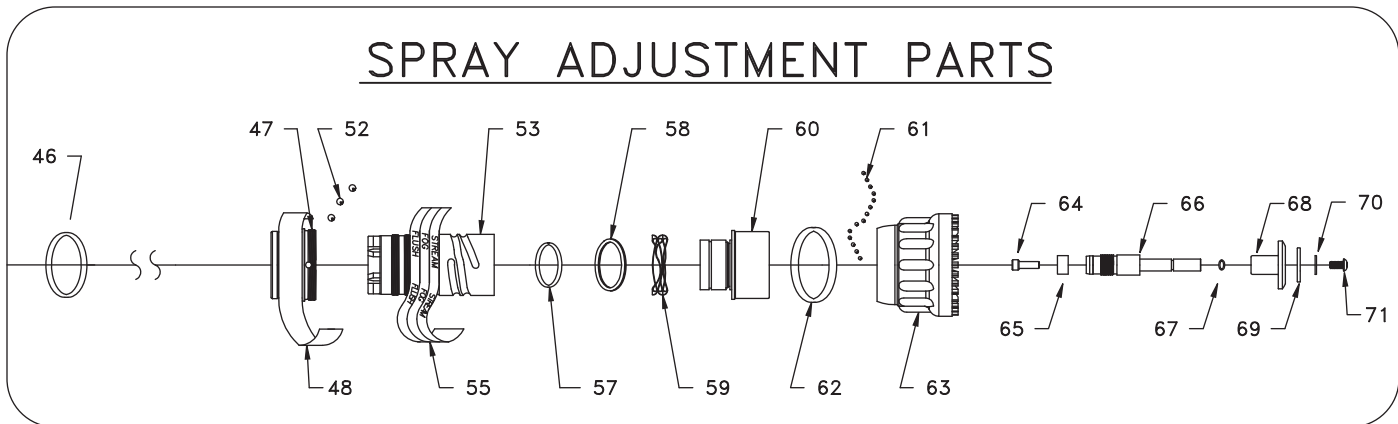

METRO 1 - SERVICE PROCEDURE PARTS LIST

	DESCRIPTION	QTY	ORDER #		DESCRIPTION	QTY	ORDER #
1	1.5" COUPLING GASKET	1	V3130	37	DETENT SCREW	2	HD785
2	1.5" ROCKER LUG COUPLING	1	HM697*	38	CAM SCREW	2	HD780
5	3/16 SS BALLS	33	V2120	39	S.T.O. VALVE PLUG	1	HM592
7	¼-28 X 3/8 SOCKET SET SCREW	1	VT25-28SS375	40	T.O. BASE	1	HM670
8	GASKET GRABBER	1	HM730	41	T.O. VALVE PLUG	1	HM591
9	O-RING-134	1	VO-134	46	O-RING-139	1	VO-139
10	VALVE BODY	1	HM600	47	SHAPER GUIDE	1	HMD510
	VALVE DISK	2	HM640	48	NAME LABEL - Metro 1	1	HM745-ORG
	DRAG NUB	4	HM650	52	TORLON GUIDE BALLS	3	VB243TO
	SMALLEY RING	2	V4270	53	FIN CAN/BARREL	1	HM545
11	VALVE HANDLE	1	HM620	55	BARREL LABEL- Orange	1	HM740-ORG
12	DETENT SPRING	2	HM770	57	O-RING-030	1	VO-030
13	DETENT BALL	2	VB243TO	58	WS-175-S02 SMALLEY RING	1	VR4230
14	HANDLE SCREW	2	HM645	59	FLUSH WAVE SPRING	1	HM785
15	CAM PIN	1	HM630	60	BARREL CONE	1	HM520
16	SAFETY PIN	1	HM635	61	1/8 NYLON BALL	64	V2135
17	VALVE HANDLE COVER	2	HM625-BLK	62	O-RING-230	1	VO-230
18	8-32 x 3/8 BUTTON HEAD CAP SCREW	4	HM626	63	SHAPER WITH BUMPER	1	HM500
19	10-32 x 3/16 SOCKET SET SCREW	2	VT10Y32SS187	64	¼-28 X ¾ SH CAP SCREW	1	VT25-28SH750
20	QUADX-4221	1	VOQ-4221	65	LOCKING SLEEVE	1	HM571
21	QUADX-4130	1	VOQ-4130	66	SHAFT	1	HM470
22	SLIDER	1	HM660	67	O-RING 011	1	VO-011
23	VALVE PLUG	1	HM590	68	BAFFLE	1	HM461
26	S.T.O. TAIL PIECE	1	HM662	69	FLOW WASHER K=12.5 OR 9.5	1	HM410-14
27	O-RING-129	1	VO-129		FLOW WASHER K=15.0 OR 14.4		HM410-15
28	O-RING-138	1	VO-138		FLOW WASHER K=17.5 OR 17.3		HM410-17
29	S.T.O. SLIDER	1	HM661		FLOW WASHER K-20.0 OR 20.2		HM410-21
30	QUADX-4037	2	VOQ-4037		FLOW WASHER K=23.1 OR 21.2		HM410-23
31	"OFF" LABEL	1	HD755	70	FLAT WASHER	1	VW687X281-50
32	"ON" LABEL	1	HD750	71	¼-28 X ½ BUTTON HEAD	1	VT25Y28BH500
33	S.T.O. BASE	1	HM655	80	PISTOL GRIP	1	HM692-BLK
34	DETENT SPRING	2	VM4200	81	SPACER	1	HM693-HM
35	3/16" TORLON BALLS	2	V2120-TORLON	82	WASHER	1	VM4901
36	S.T.O. SLEEVE	1	HM668	83	3/8-16 X 1 SOCKET HEAD CAP SCREW	1	VT37-16SH1.0

* Specify Thread

10.0 METRO 2 DRAWINGS & PART LIST

BACK END PARTS

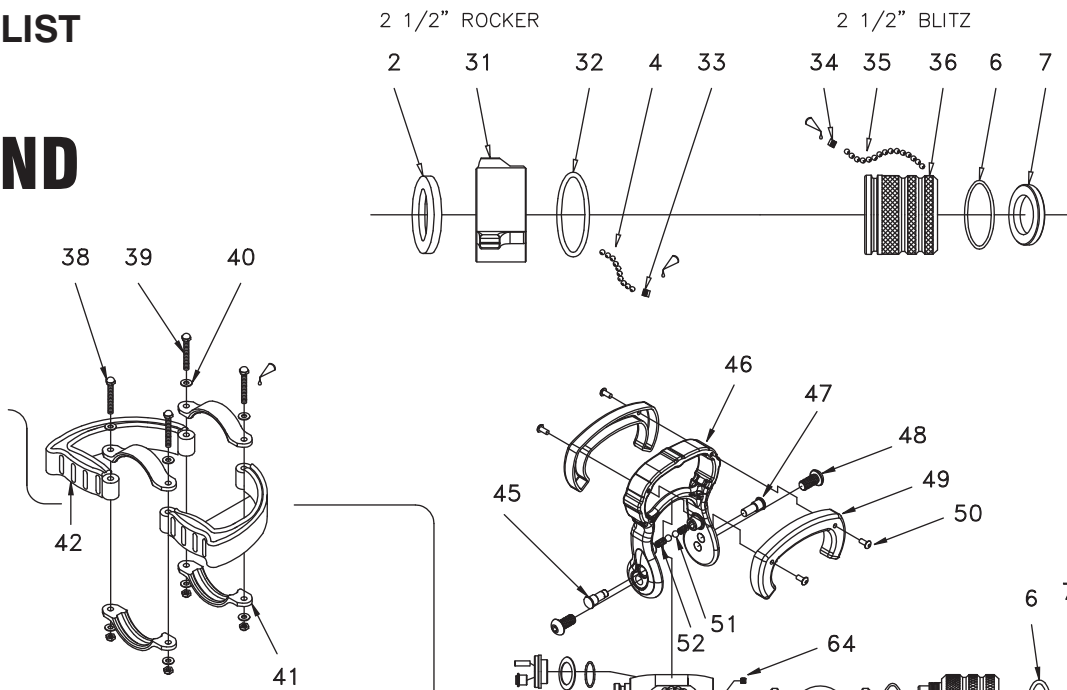

COUPLINGS

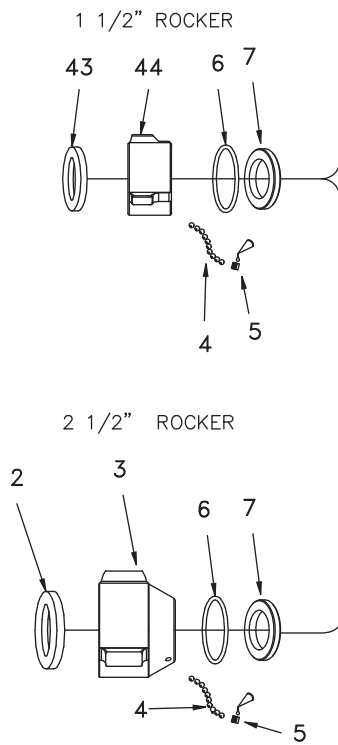

VALVE PARTS

SPRAY ADJUSTMENT PARTS

FRONT END PARTS

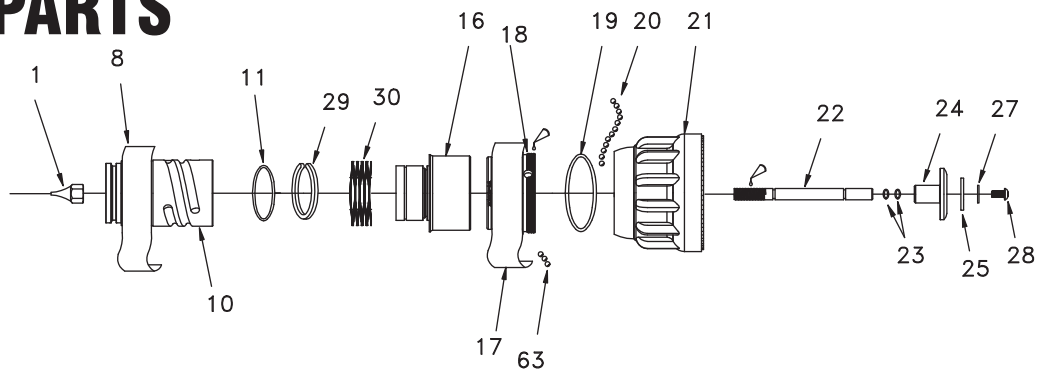

METRO 2 - SERVICE PROCEDURE PARTS LIST

	DESCRIPTION	QTY	ORDER #		DESCRIPTION	QTY	ORDER #
1	CAP NUT	1	H420	35	3/16 SS BALL	38	V2120
2	GASKET - 2.5" HOSE COUPLING	1	V3190	36	2.5" BLITZ BASE	1	H675
3	COUPLING 2.5" NH ROCKERLUG	1	P198N (P198I NPSH)	38	1/4-20 ACORN NUT STAINLESS	8	VT25E20AC
				39	1/4-20 X 2" STUD STAINLESS	4	VT25-20ST2.0
4	3/16" BALL - 302 STAINLESS	37	V2120	40	1/4 WASHER	8	VW500X265-63
5	1/4-28 X 3/16 SOCKET SET SCREW	1	VT25-28SS187 (SWIVEL)	41	BLITZ BRACKET	4	H676
	1/4-28 X 3/8 SOCKET SET SCREW		VT25-28SS375 (LOCK-OUT)	42	PLAYPIPE HANDLE	2	P220
				43	1.5" GASKET	1	V3130
				44	1.5" ROCKERLUG COUPLING	1	H694
6	O-RING-141 2-5/16 ID 3/32 C/S	1	VO-141	45	SAFETY PIN	1	HX635
7	ANTI GG RING	2	P147	46	VALVE HANDLE	1	HX620
8	BARREL LABEL ORANGE	1	H740-ORG	47	CAM PIN	1	HX630
10	BARREL	1	HX440	48	HANDLE SCREW	2	VT37E24BH750
11	O-RING-033	1	VO-033	49	BLACK HANDLE COVER	2	HM625-BLK
16	BARREL CONE	1	HX520	50	8-32 X 3/8 BUTTON HEAD	4	HM626-1
17	METRO2 NAME LABEL ORANGE	1	H745-ORG	51	BALL .243" - TORLON	2	VB243TO
18	SHAPER GUIDE	1	HXD510	52	DETENT SPRING	2	HM770
19	O-RING-336 2-7/8 ID 3/16 C/S	1	VO-336	53	DETENT VALVE BODY	1	P110
20	3/16" BALL ACETAL	48	V2115		BLUE VALVE LABEL	1	H750
21	SHAPER WITH BUMPER	1	H500	54	BALL VALVE SEAT	2	P104
22	SHAFT	1	HX470	55	BALL VALVE	1	P103
23	O-RING-011 5/16 ID 1/16 C/S	2	VO-011	56	O-RING 227	1	VO-227
24	BAFFLE	1	H461	57	PLAYPIPE ADAPTER	1	HX450
25	FLOW WASHER	1		58	GRIP SPACER	1	HM693-H
	FLOW WASHER K=17.0 OR K=14.4		HX410-16	59	PISTOL GRIP	1	HM692-BLK
	FLOW WASHER K=23.1 OR K=21.3		HX410-22	60	FLAT WASHER	1	VM4901
	FLOW WASHER K=28.9 OR K=25.0		HX410-26	61	3/8-16 X 1 SOCKET HEAD CAP	1	VT37-16SH1.0
	FLOW WASHER K=35.4 OR K=32.5		HX410-34	62	3/8-24 X 3/8 SOCKET SET SCREW	1	VT37-24SS375
27	FLAT WASHER	1	VW687X281-50	63	BALL .344" TORLON	3	VB344TO
28	1/4-28 BUTTON HEAD SCREW	1	VT25Y28BH500	64	10-32 x 3/16 SOCKET SET SCREW	2	VT10Y32SS187
29	SMALLEY RING	1	VR4270	65	3/16 X 9/16 HDP SPIROL	2	V2005
30	WAVE SPRING	1	HX785	66	TRUNNION DRIVER	2	HX650
31	2.5" ROCKERLUG COUPLING	1	P197	67	TRUNNION LEFT	1	P120L
32	O-RING 151	1	VO-151		TRUNNION RIGHT	1	P120R
33	1/4-28 X 1/4 SET SCREW	1	VT25-28SS250	68	TRUNNION SHIM	2	P170
34	1/4-28 X 3/8 SOCKET SET SCREW	1	VT25-28SS375	69	O-RING 118	2	VO-118

* Specify Thread

11.0 INSPECTION CHECKLIST

Nozzle must be inspected before each use for proper operation and function according to this checklist. Check that:

- 1) There is no obvious damage such as missing, broken or loose parts, damaged labels, etc.
- 2) Coupling is tight and leak free
- 3) Valve handle moves freely through full range and shuts off flow
- 4) Nozzle flow is adequate as indicated by pump pressure and nozzle reaction
- 5) Shaper turns freely and adjusts pattern through full range
- 6) Nozzle moves smoothly in and out of flush position

▲WARNING

Any nozzle failing any part of the inspection checklist is unsafe and must have the problem corrected before use. Operating a nozzle that fails any of the above inspections is a misuse of this equipment.

12.0 WARRANTY

Task Force Tips, Inc., 3701 Innovation Way, Valparaiso, Indiana 46383-9327 USA ("TFT") warrants to the original purchaser of its Metro series nozzles ("equipment"), and to anyone to whom it is transferred, that the equipment shall be free from defects in material and workmanship during the five (5) year period from the date of purchase.

TFT's obligation under this warranty is specifically limited to replacing or repairing the equipment (or its parts) which are shown by TFT's examination to be in a defective condition attributable to TFT. To qualify for this limited warranty, the claimant must return the equipment to TFT, at 3701 Innovation Way, Valparaiso, Indiana 46383-9327 USA, within a reasonable time after discovery of the defect. TFT will examine the equipment. If TFT determines that there is a defect attributable to it, TFT will correct the problem within a reasonable time. If the equipment is covered by this limited warranty, TFT will assume the expenses of repair.

If any defect attributable to TFT under this limited warranty cannot be reasonably cured by repair or replacement, TFT may elect to refund the purchase price of the equipment, less reasonable depreciation, in complete discharge of its obligations under this limited warranty. If TFT makes this election, claimant shall return the equipment to TFT free and clear of any liens and encumbrances.

This is a limited warranty. The original purchaser of the equipment, any person to whom it is transferred, and any person who is an intended or unintended beneficiary of the equipment, shall not be entitled to recover from TFT any consequential or incidental damages for injury to person and/or property resulting from any defective equipment manufactured or assembled by TFT. It is agreed and understood that the price stated for the equipment is in part consideration for limiting TFT's liability. Some states do not allow the exclusion or limitation of incidental or consequential damages, so the above may not apply to you.

TFT shall have no obligation under this limited warranty if the equipment is, or has been, misused or neglected (including failure to provide reasonable maintenance) or if there have been accidents to the equipment or if it has been repaired or altered by someone else.

THIS IS A LIMITED EXPRESS WARRANTY ONLY. TFT EXPRESSLY DISCLAIMS WITH RESPECT TO THE EQUIPMENT ALL IMPLIED WARRANTIES OF MERCHANTABILITY AND ALL IMPLIED WARRANTIES OF FITNESS FOR A PARTICULAR PURPOSE. THERE IS NO WARRANTY OF ANY NATURE MADE BY TFT BEYOND THAT STATED IN THIS DOCUMENT.

This limited warranty gives you specific legal rights, and you may also have other rights which vary from state to state.

TASK FORCE TIPS, Inc.
Made in USA • www.tft.com

3701 Innovation Way • Valparaiso, IN 46383-9327 USA
800-348-2686 • 219-462-6161 • Fax 219-464-7155