



MANUAL: IVUM 4 4" INDUSTRIAL VALVE UNDER MONITOR

INSTRUCTIONS FOR INSTALLATION, SAFE OPERATION AND MAINTENANCE

⚠ WARNING

Read Instruction Manual before use. Operation of this device without understanding the manual and receiving proper training can be dangerous and is a misuse of this equipment. Download this manual from <http://tft.com/>. Call 800-348-2686 with any questions.

NOTICE

This Instruction Manual is intended to familiarize firefighters and maintenance personnel with the operation, servicing and safety procedures associated with the Industrial Valve Under Monitor.

NOTICE

This Instruction Manual should be kept available to all operating and maintenance personnel.

HYDROSTATIC PROOF TEST:

1220 psi (84 bar)

SAFE OPERATING RANGE:

Up to 2500 gpm below 130 psi*

(9500 l/min @ 9 bar)

Up to 2000 gpm below 200 psi*

(8000 l/min @ 14 bar)

Up to 1600 gpm @ 300 psi maximum*

(6000 l/min @ 21 bar)

*these maximum flow rates and nozzle inlet pressures are valid for monitor outlets up to 18.6" (472mm) tall from the IVUM outlet. Read section 4.2 for details.

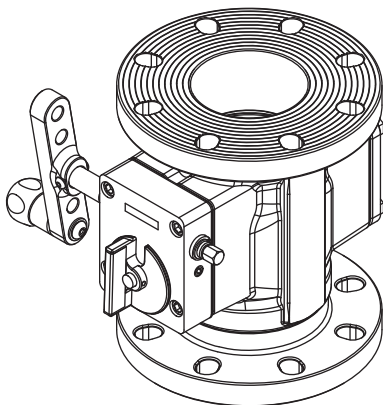

model ZAAZ3 or ZASZ3
with 4" ANSI 150 outlet
(shown from gearbox side)

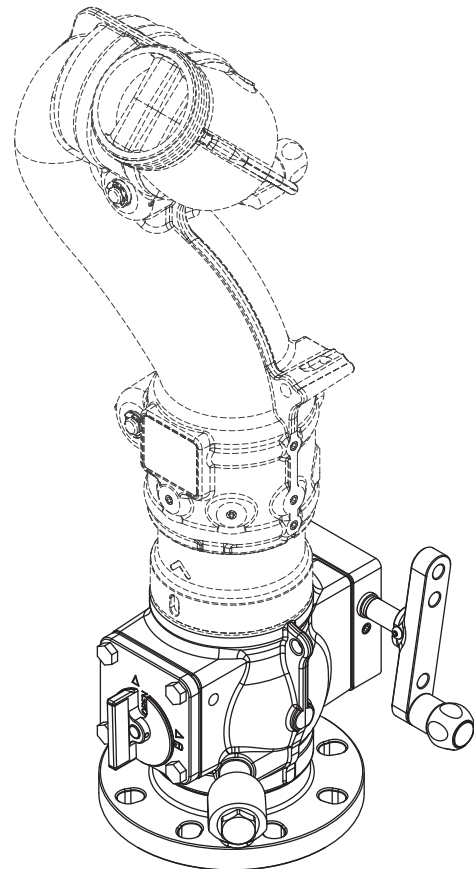

model ZAAZX or ZASZX
for integrated TFT monitor
(shown from secondary position indicator side with Y5-D21A-Z)

TASK FORCE TIPS, INC.
MADE IN USA • www.tft.com

3701 Innovation Way, Valparaiso, IN 46383-9327 USA
800-348-2686 • 219-462-6161 • Fax 219-464-7155

Table Of Contents

1.0	MEANING OF SAFETY WORDS.....	3
2.0	SAFETY	3
3.0	GENERAL INFORMATION	4
3.1	MECHANICAL SPECIFICATIONS	4
3.2	CORROSION	4
3.3	USE WITH SALT WATER	4
3.4	PARTS IDENTIFICATION AND INTENDED ORIENTATION	4
3.5	OVERALL DIMENSIONS AND WEIGHTS.....	5
3.6	SIDE 'B' MONITOR OUTLET OPTIONS.....	6
4.0	INSTALLATION	8
4.1	STRUCTURAL REQUIREMENTS FOR MONITOR MOUNTING	8
4.2	MONITOR INSTALLATION	8
4.2.1	SIDE 'B' OPTIONS 3, 4, V – FLANGED MONITORS.....	9
4.2.2	SIDE 'B' OPTION X – INTEGRATED MONITORS	9
4.2.3	SIDE 'B' OPTIONS Q and T – QUICK CONNECT FOR MONITORS AND ELBOWS.....	9
4.2.4	SIDE 'B' OPTIONS 1 and 2 – CODE-RPM DIRECT CONNECTION	10
5.0	USE	11
5.1	OPERATION AND VALVE POSITION INDICATORS.....	11
5.2	LOCKOUT/TAGOUT	11
5.3	AUTOMATIC WATER DRAIN VALVE.....	11
6.0	EXPLODED VIEWS AND PARTS LISTS.....	12
6.1	MAIN VALVE ASSEMBLY EXPLODED VIEW.....	12
6.2	MAIN VALVE ASSEMBLY PARTS LIST	13
6.3	HALF BALL [A] EXPLODED VIEWS.....	14
6.4	HALF BALL [A] PARTS LIST.....	14
6.5	SECONDARY POSITION INDICATOR [B] EXPLODED VIEW.....	15
6.6	SECONDARY POSITION INDICATOR [B] PARTS LIST	15
6.7	WORM GEARBOX [C] EXPLODED VIEW	16
6.8	WORM GEARBOX [C] PARTS LIST.....	16
7.0	MAINTENANCE AND REPAIRS.....	17
7.1	CRANKSHAFT OVERRIDE AND REPLACEMENT.....	17
7.2	VALVE SEAT REPLACEMENT	18
8.0	PRESSURE LOSS.....	19
9.0	WARRANTY.....	20
10.0	ANSWERS TO YOUR QUESTIONS.....	20

DANGER

PERSONAL RESPONSIBILITY CODE





The member companies of FEMSA that provide emergency response equipment and services want responders to know and understand the following:

1. Firefighting and Emergency Response are inherently dangerous activities requiring proper training in their hazards and the use of extreme caution at all times.
2. It is your responsibility to read and understand any user's instructions, including purpose and limitations, provided with any piece of equipment you may be called upon to use.
3. It is your responsibility to know that you have been properly trained in Firefighting and /or Emergency Response and in the use, precautions, and care of any equipment you may be called upon to use.
4. It is your responsibility to be in proper physical condition and to maintain the personal skill level required to operate any equipment you may be called upon to use.
5. It is your responsibility to know that your equipment is in operable condition and has been maintained in accordance with the manufacturer's instructions.
6. Failure to follow these guidelines may result in death, burns or other severe injury.







Fire and Emergency Manufacturers and Service Association
P.O. Box 147, Lynnfield, MA 01940 • www.FEMSA.org

1.0 MEANING OF SAFETY WORDS

A safety related message is identified by a safety alert symbol and a signal word to indicate the level of risk involved with a particular hazard. Per ANSI standard Z535.6-2006, the definitions of the four signal words are as follows:

-  **DANGER** indicates a hazardous situation which, if not avoided, will result in death or serious injury.
-  **WARNING** indicates a hazardous situation which, if not avoided, could result in death or serious injury.
-  **CAUTION** indicates a potentially hazardous situation which, if not avoided, may result in minor or moderate injury.
-  **NOTICE** is used to address practices not related to personal injury.

2.0 SAFETY

-  **WARNING** Injury or death may occur by attempting to use a damaged Industrial Valve Under Monitor. Before using the valve inspect it for damage resulting from:
- Exposure of monitor to temperatures in excess of 160 degrees F
 - Missing parts, physical abuse, exposure to severe chemicals
 - Failure to drain standpipe followed by exposure to freezing conditions. Draining can be performed using the automatic drain valve option. See section 6.0 for instructions.
-  **WARNING** This equipment is intended for use by trained personnel for firefighting. Its use for other purposes may involve hazards not addressed by this manual. See appropriate guidance and training to reduce risk of injury.
-  **CAUTION** Maximum operating pressure 300 PSI (21 bar). Exceeding 300 psi (21 bar) on either side of the valve may damage valve and could cause injury.
-  **CAUTION** Valve must be properly connected. Mismatched or damaged connectors may cause leaking or uncoupling under pressure and could cause injury.
-  **CAUTION** Any alterations to the valve and its markings could diminish safety and constitutes a misuse of this product.
-  **CAUTION** Dissimilar metals coupled together can cause galvanic corrosion that can result in the inability to unscrew threads and complete loss of thread engagement over time. Use of flange isolation kits and anti-corrosive lubricant such as Dow Corning 112 Silicone Grease is recommended to prevent galvanic corrosion.

3.0 GENERAL INFORMATION

The 4" Industrial Valve Under Monitor (IVUM) is a robust, low friction loss valve intended for installation directly beneath monitors on standpipes with 4" ANSI 150 or DN 80 PN16 flange connections. Dual reflective valve position indicators allow 360 degree visual confirmation from a distance in all light conditions. The inlet flange, half ball and valve seat retainer are available in either hard anodized 6061-T6 aluminum or 316 stainless steel. Several options are available for monitor connection, as described in section 3.6. When paired with a TFT monitor, the monitor flange is omitted to reduce weight, up-front cost and future maintenance expenses.

3.1 MECHANICAL SPECIFICATIONS

MODEL	4" IVUM with Aluminum Inlet Parts	4" IVUM with Stainless Steel Inlet Parts
Valve seat Diameter	3.65" (93mm)	3.65" (93mm)
Maximum Pressure	300 psi (21 bar)	300 psi (21 bar)
Maximum Flow at Specified Nozzle Inlet Pressures	2500 gpm @ 130 psi (9500 l/min @ 9 bar) 2000 gpm @ 200 psi (8000 l/min @ 14 bar) 1600 gpm @ 300 psi (6000 l/min @ 21 bar)	
Hydrostatic Proof	1220 psi (84 bar)	1220 psi (84 bar)
Temperature Rating*	-25° to 135°F (-32° to 57°C)	-25° to 135°F (-32° to 57°C)
*for temperatures below 32°F (0°C), standpipe must be drained after use to avoid damage. See section 5.3 AUTOMATIC WATER DRAIN VALVE for instructions.		

3.2 CORROSION

The valve body is hard anodized and powder coated to help prevent corrosion. Galvanic corrosion due to dissimilar metals can be prevented by using flange isolation kits. Where practical, the standpipe should be drained while not in use to eliminate a path of conduction.

3.3 USE WITH SALT WATER

Use with salt water is permissible provided valve is thoroughly cleaned with fresh water after each use. The service life of the valve may be shortened due to the effects of corrosion and is not covered under warranty.

3.4 PARTS IDENTIFICATION AND INTENDED ORIENTATION

When installed in the orientation shown in figure 1, the external automatic drain valve shown will allow the valve and monitor to drain fully after use. An optional internal automatic drain valve allows the standpipe to drain even while the valve is closed. See section 5.0 for details.

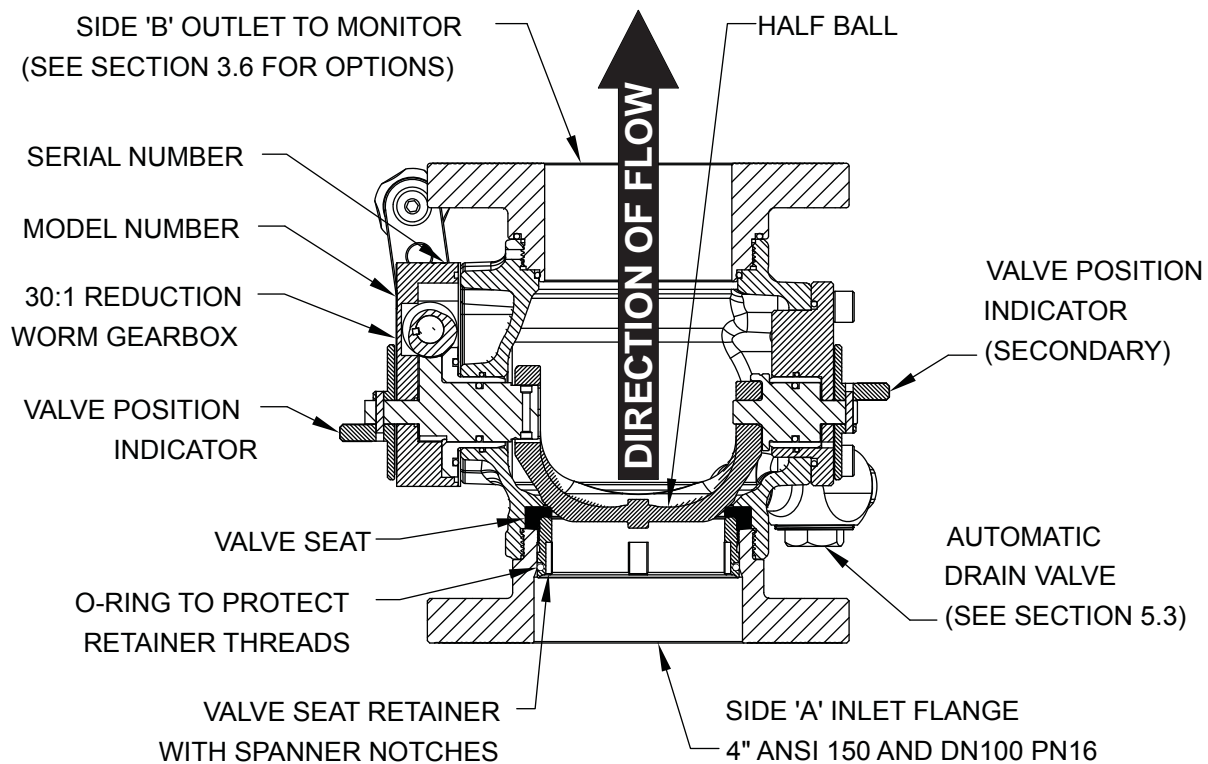

Figure 1: Parts Identification

3.5 OVERALL DIMENSIONS AND WEIGHTS

The overall height and weight of the IVUM vary according to the side 'A' inlet material (see table 2 below) and choice of side 'B' outlet to monitor (see section 3.6). The overall height and weight are equal to the sums of the values from figures 2 and 3 and tables 2 and 3.

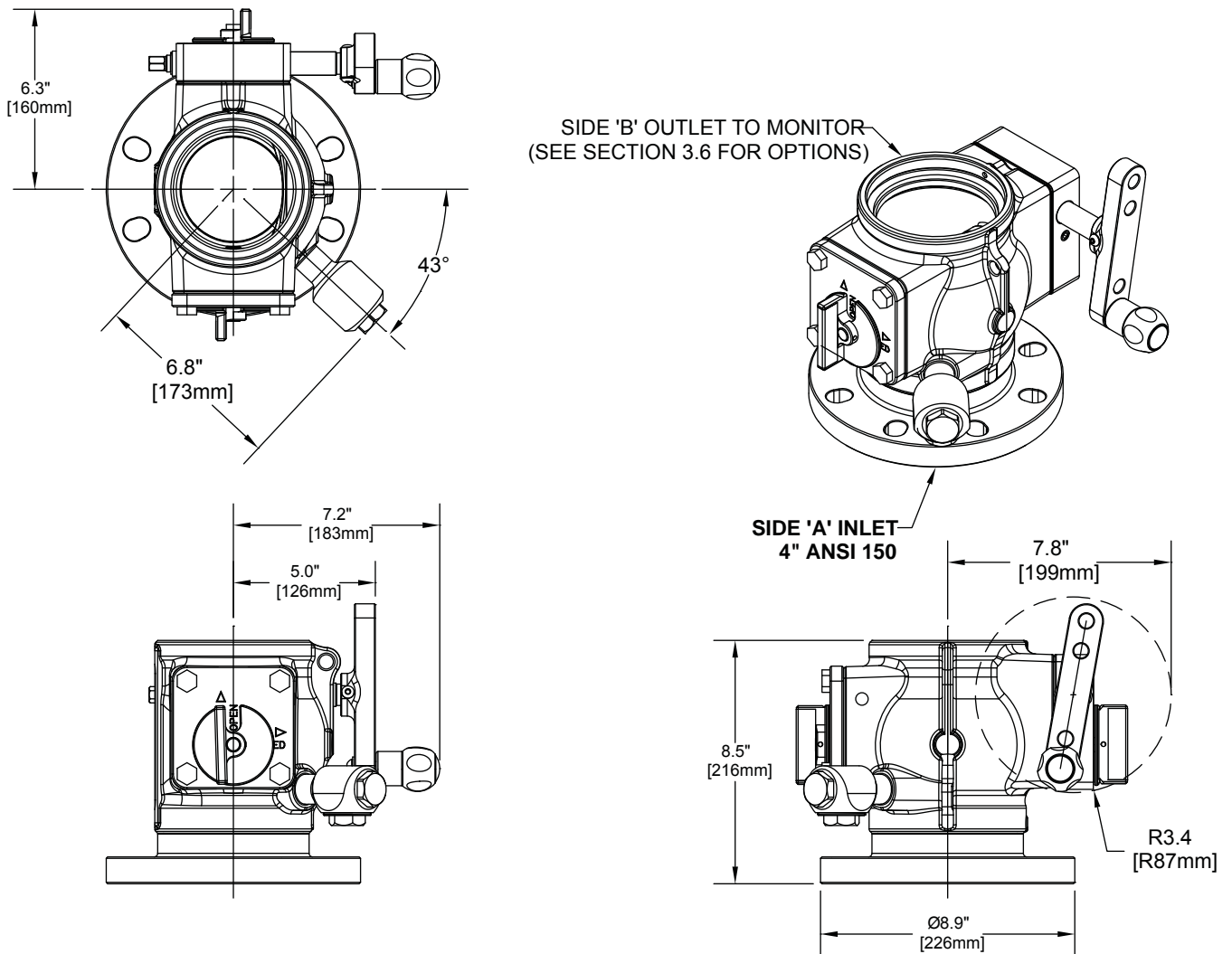

Figure 2: Basic dimensions without monitor outlet

MODEL	SIDE 'A' Option for Flange, Seat Retainer and Half Ball	WEIGHT – lb (kg)
ZAAD*	Hard anodized Aluminum with internal drain in half ball	18.3 (8.3)
ZAAZ*	Hard anodized Aluminum without drain in half ball	18.3 (8.3)
ZASD*	316 Stainless Steel with internal drain in half ball	29.6 (13.4)
ZASZ*	316 Stainless Steel without drain in half ball	29.6 (13.4)

*Third character of model number signifies inlet material ('A' for aluminum; 'S' for stainless steel).
 Fourth character of model number signifies the internal drain option ('D' for drain; 'Z' for no drain).
 All models come standard with an external automatic drain valve.*

Table 2: Basic weight without monitor outlet

3.6 SIDE 'B' MONITOR OUTLET OPTIONS

Several options are available for connecting a monitor to the IVUM. Descriptions, weights and linear dimensions of each option are given in table 3 and figure 3.

DESCRIPTION	OPTION	PART NUMBER	WEIGHT lb (kg)	
CODE-RPM direct connection for TFT monitor, STRAIGHT	1	A1026.4	4.0	(1.8)
CODE-RPM direct connection for TFT monitor, ANGLED 22.5°	2	A1040.4	5.0	(2.3)
4" ANSI 150 FLANGE, STRAIGHT	3	A2080	5.4	(2.4)
4" ANSI 150 FLANGE, ANGLED 22.5°	4	A1039.4	9.7	(4.4)
QUICK CONNECT - 4.5"NH (for Monsoon, Typhoon, Hurricane & 90° Elbow)	Q	Y4484.4	4.5	(2.0)
QUICK CONNECT - 2.5"NHM (for Tornado)	T	Y2432A.4	4.3	(1.9)
TORNADO INTEGRATED BASE FOR VUM (built-into Tornado monitors Y2-TV1A and Y2-EV1A only)	V	N/A	2.2	(1.0)
LARGE MONITOR INTEGRATED BASE FOR IVUM (built-in to Monsoon, Typhoon & Hurricane monitor models with 'X' inlet option)	X	N/A	0.0	(0.0)

Table 3: Side "B" Monitor Outlet Options

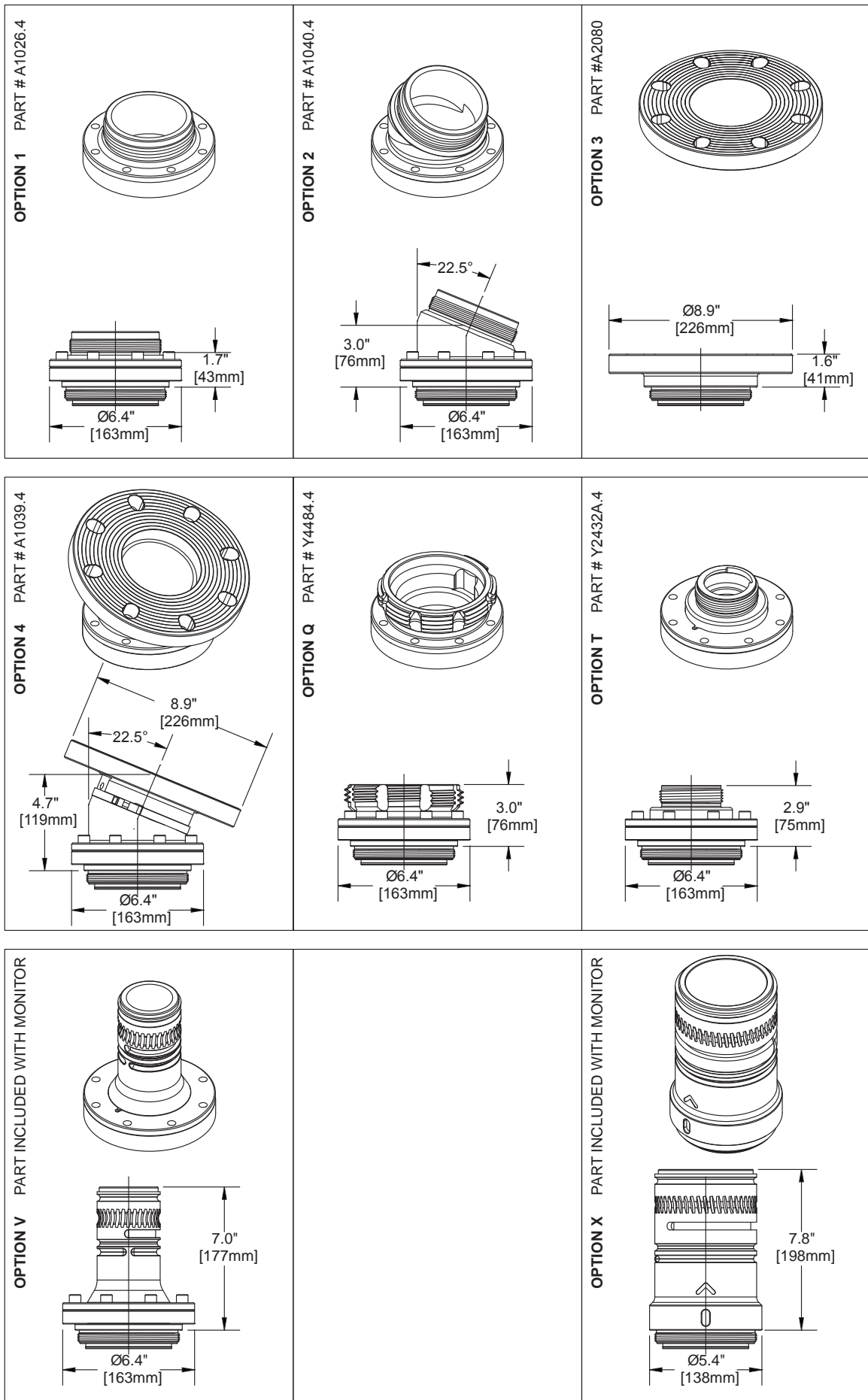

Figure 3: Side "B" Monitor Outlet Options

4.0 INSTALLATION

4.1 STRUCTURAL REQUIREMENTS FOR PIPE FLANGE MOUNTED MONITORS

WARNING

Injury can result from an inadequately supported monitor. The structure to which the Industrial Valve Under Monitor is mounted must be capable of withstanding the internal pressure of the monitor as well as shear and bending forces due to nozzle reaction. Nozzle reaction can be as high as 1500 lbs (680 kg) (2000 gpm at 200 psi, 1600 gpm at 300 psi). Flanges and pipe made from plastic are inadequate for valve mounting and must not be used. This valve is not intended for portable use.

This section pertains to bolting the valve to the standpipe, as well as bolting the monitor to the valve for SIDE B options 3, 4, V and W. The use of flat flanges without raised faces is recommended. Use a ring gasket as defined in ASME 16.21 or ISO 7483. Tighten flange bolts in an alternating sequence as shown in figure 4. For 4" ANSI 150 connection with 5/8-11 bolts or studs, tighten to 76-80 ft-lb (100-110 Newton-meters). See section 4.2 for SIDE B instructions and torque requirements.

Tighten sequentially each bolt three times.

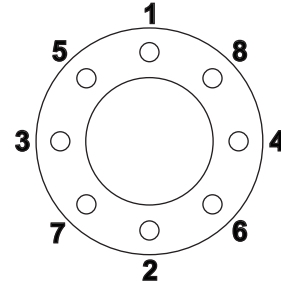

Figure 4: Flange Bolt Tightening Sequence

4.2 MONITOR INSTALLATION

WARNING

Keep monitor discharge height within acceptable limits. Injury can result from the reaction forces when the monitor discharge height is more than 18.6" (472 mm) from the valve outlet. Avoid use of exceptionally tall monitors, accessories between valve and monitor, or telescopic waterways such as the Task Force Tips Extend-A-Gun which exceed the acceptable monitor discharge height.

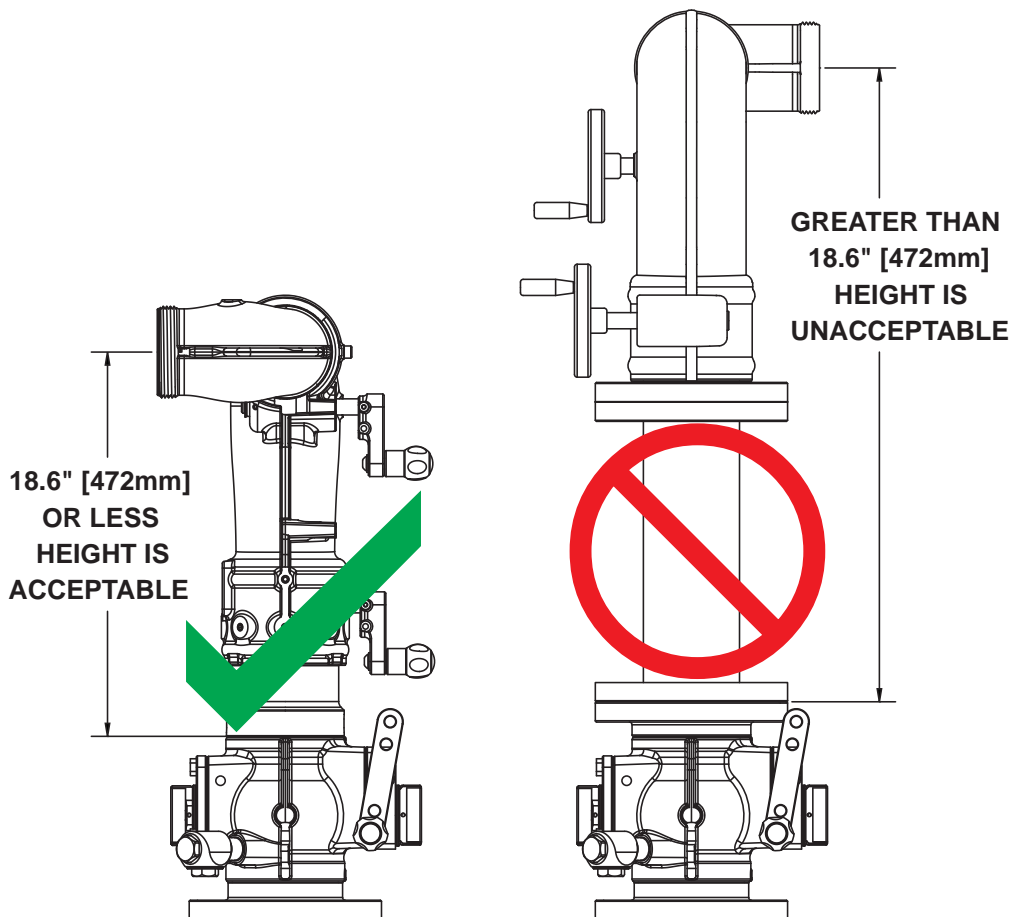

Figure 5: Acceptable Monitor Height

4.2.1 SIDE 'B' OPTIONS 3, 4, V – FLANGED MONITORS

Install monitor on valve using the alternating bolt tightening sequence shown in figure 4.

1. For options 3 and 4, install a ring gasket and tighten 5/8-11 bolts or studs to 76-80 ft-lb (100-110 N-m).
2. For options V and W, install an o-ring on barb protruding from bottom of flange and apply silicone grease over o-ring. Align as desired, then draw o-ring into valve body by partially tightening alternate bolts.
3. For option V - Tornado monitor, torque 3/8-16 x 1.0" long bolts to 180 to 200 in-lb (15-17 ft-lb; 20-23 N-m).

4.2.2 SIDE 'B' OPTION X – INTEGRATED MONITORS

Refer to figure 6 below.

1. Apply silicone grease to barb protruding from male threads on monitor base. Slide o-ring over barb, then apply silicone grease over the o-ring, being careful not to get grease on the threads.
2. Apply silicone grease to face seal groove near thread, then install o-ring into groove. Apply silicone grease over the o-ring, being careful not to get grease on the threads.
3. Apply Loctite 242 (blue) to female threads in side 'B' of valve. Install monitor on valve and tighten with spanner wrench until the joint is bottomed out.
4. Apply Loctite 242 (blue) to 1/4-20 x .25" long cup point set screw. Tighten screw against male thread.
5. If disassembly is needed for maintenance, heating the monitor inlet with a torch may be beneficial.

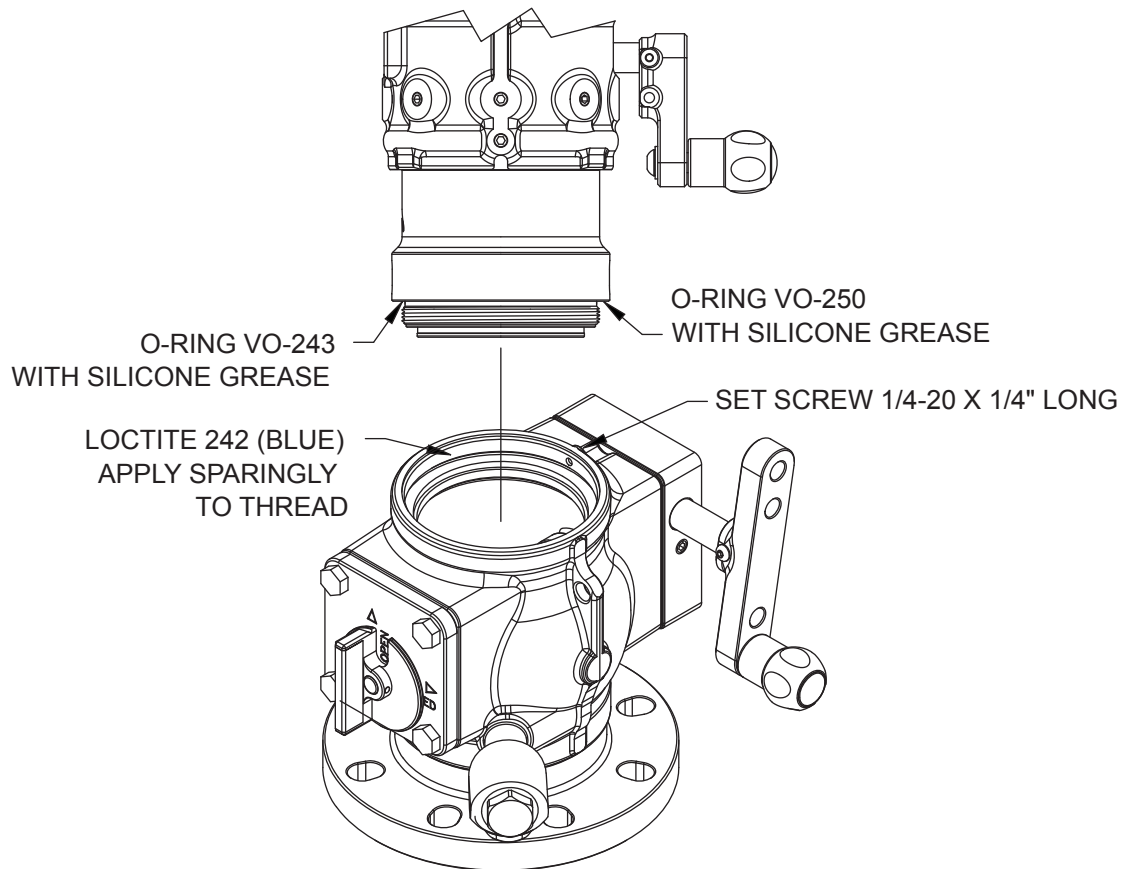

Figure 6: Side 'B' Option X

4.2.3 SIDE 'B' OPTIONS Q and T – QUICK CONNECT FOR MONITORS AND ELBOWS

1. See monitor manuals and quick connect supplement for details (literature numbers LIY-250 and LIY-300).
2. If equipped with locking pin, hold pin out and push coupling up as far as it will go, then release locking pin. This will hold the coupling out of the way while mounting the monitor on the base.
3. Align tongue(s) of female inlet into notches within male threaded outlet. This serves as a rotational lock.
4. Rotate coupling clockwise until threads engage on male threaded outlet, then release locking pin (if so equipped). Continue to rotate coupling until tight. Locking pin will ratchet across detents, but it is not necessary to over-tighten coupling if locking pin ends up between detent positions. To prevent damage, do not use locking pin as a lever to tighten or loosen coupling.

4.2.4 SIDE 'B' OPTIONS 1 and 2 – CODE-RPM DIRECT CONNECTION

TWO PIECE CLAMP ROTATIONAL LOCK INSTRUCTIONS (without tapped holes - refer to figure 7):

1. Assemble Clamps and place loosely on IVUM outlet.
2. Screw monitor onto VUM until threaded joint bottoms out.
 - CAUTION: Make sure the Clamps are not tight enough to prevent the monitor Base from bottoming out. The monitor will leak if it does not bottom out in this step.
 - Do not use pipe dope or Loctite on the monitor base threads. These threads are sealed with an O-ring. The use of thread locking compounds will make removal difficult.
3. Unscrew monitor until the "Straight Ahead Reference Mark" is facing the desired direction.
 - Monitor may be unscrewed up to one full turn from the bottomed out position.
 - CAUTION: Monitor will leak if unthreaded more than one full rotation from bottomed-out condition.
4. Rotate the Clamps to the desired orientation. Ensure that Clamp assembly does not interfere with RC monitor Power/Com Cable (if applicable).
5. Tighten each Screw gradually until both are finger tight with approximately equal spacing between opposite ends of Clamps.
6. Carefully tighten each Screw one additional turn using a 5/32 hex wrench by alternating to the opposite Screw in half turn increments. CAUTION: Over tightening the Screws will damage Screws and Clamps.

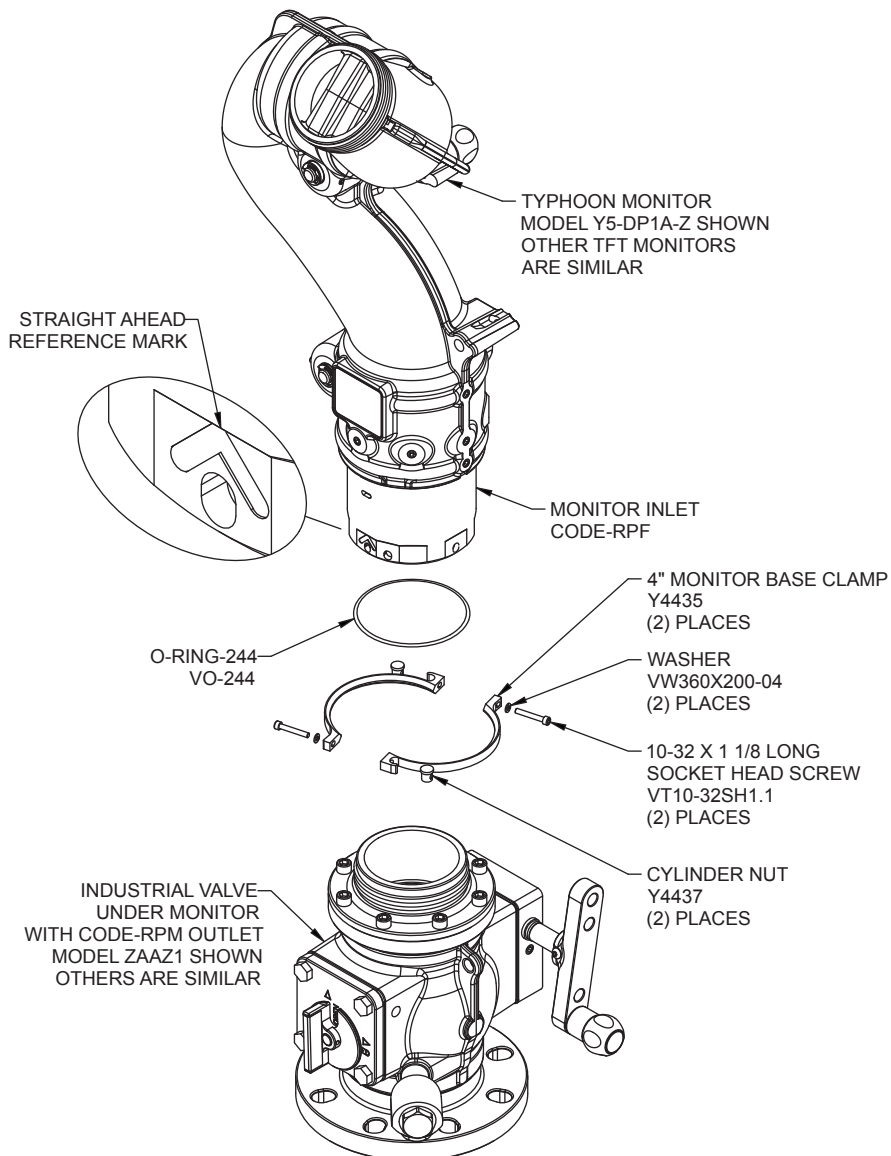

Figure 7: CODE-RPM Direct Connection

5.0 USE

5.1 OPERATION AND VALVE POSITION INDICATORS

To open the valve, turn the crank handle counter-clockwise until the pointer on the gearbox indicates "OPEN". To close the valve, turn the crank handle clockwise until the pointer indicates "CLOSED". A secondary position indicator is included on the opposite side of the valve to allow 360° verification of valve position. When the valve is open, reflective flags on each indicator are parallel to the direction of flow through the valve. See figure 8.

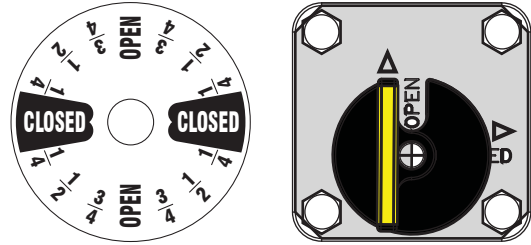

Figure 8: Valve Position Indicators

5.2 LOCKOUT/TAGOUT

Tether points have been provided on the valve body and both sides of the crank handle to prevent operation of the valve. To minimize the ability to rotate the shaft, tether the nearest end of the crank handle to the valve body with minimal slack.

5.3 AUTOMATIC WATER DRAIN VALVE



Injury or death may occur by attempting to use a damaged Industrial Valve Under Monitor.

Before using the valve inspect it for damage resulting from:

- Exposure to temperatures in excess of 160 degrees F
- Missing parts, physical abuse
- Failure to drain standpipe followed by exposure to freezing conditions.

EXTERNAL DRAIN VALVE

All Industrial VUMs are equipped with an external automatic drain valve attached to a port directly above the valve seat. The drain valve allows the monitor and valve body to drain fully after the half ball is closed, thus minimizing susceptibility to damage from corrosion and freezing water. The drain valve is designed to close automatically when pressure exceeds 5 psi. When pressure drops below 5 psi, the drain valve will open. This is dependent on proper assembly, which should be verified visually and functionally prior to fire ground use. If the external drain valve becomes damaged to the extent that it leaks excessively, it may be temporarily replaced with a 3/4" NPT plug during monitor operation. Loosen the plug to drain the monitor following use, and replace it with a functional drain valve assembly as soon as possible.

The external drain valve is assembled within a two piece housing which threads into the valve body using 3/4" NPT threads. See index numbers 10 through 15 in sections 6.1 and 6.2 for a view of the assembly.

INTERNAL DRAIN VALVE

An optional internal automatic drain valve located within the half ball allows the standpipe to draw atmospheric air to facilitate draining, even while the half ball is closed. It is beneficial in applications where the standpipe will typically be drained following use, especially where freezing conditions are a concern. If the internal drain valve is not included, the half ball must be manually opened and the standpipe drained below the freeze line to protect the equipment from freezing conditions.

The internal drain valve is fastened directly to the outside of the half ball. See index numbers 5 through 7 in sections 6.3 and 6.4 for a view of the assembly.

USE ON TELESCOPING WATERWAYS (AERIAL APPARATUS)

Specifying the internal automatic drain valve is highly recommended to assist draining and retracting of telescoping waterways. The internal automatic drain valve is only functional after pressure has been relieved from the waterway and will not serve as a pressure relief valve under any circumstances.

After pressure has been relieved, the internal drain valve allows water and atmospheric air to backflow through the monitor and IVUM to drain the waterway, even if the IVUM remains closed. Then, the internal drain valve allows air to vent out to the atmosphere as the waterway is retracted.

If the internal drain valve is not included, then the IVUM must be opened prior to draining and retracting the waterway. Otherwise, damage to the waterway may occur if no other atmospheric vent orifice is present.

6.0 EXPLODED VIEWS AND PARTS LISTS

6.1 MAIN VALVE ASSEMBLY EXPLODED VIEW

Half Ball [A], Secondary Position Indicator [B], and Worm Drive Gearbox [C] Assemblies shown on following pages

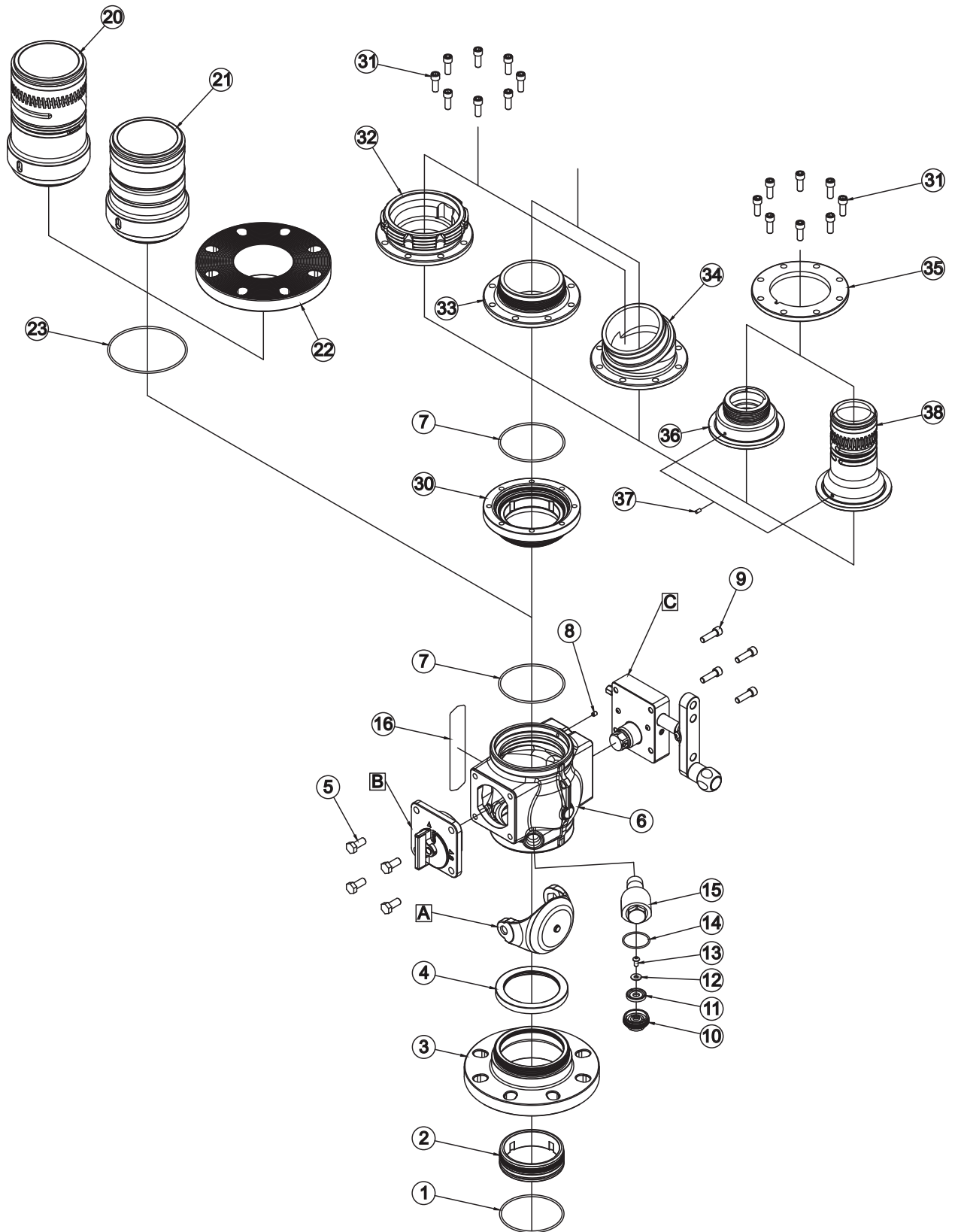

6.2 MAIN VALVE ASSEMBLY PARTS LIST

INDEX	DESCRIPTION	QTY	PART #
1	O-RING-242	1	VO-242
2	INNER SEAT RETAINER ALUM	1	A2071A
	INNER SEAT RETAINER STAINLESS		A2071S
3	INLET FLANGE 4"ANSI 150 ALUM	1	A2070A
	INLET FLANGE 4"ANSI 150 STAINLESS		A2070S
4	VALVE SEAT	1	A1520
5	7/16-14 X 1 HEX HEAD BOLT	4	VT43-14HX1.0
6	VALVE BODY IVUM 4"	1	A2002
7	O-RING-243	2	VO-243
8	1/4-20 X 1/2 SOCKET SET SCREW CUP POINT	1	VT25-20SS500
9	3/8-16 X 1 1/4 SOCKET HEAD CAP SCREW	4	VT37-16SH1.2
10	DRAIN HOUSING	1	X375
11	DRAIN VALVE	1	X382
12	FLAT WASHER 1/4"	1	VW687X281-50
13	1/4-20 X 1/2 BUTTON HEAD SCREW	1	VT25-20BH500
14	O-RING-130	1	VO-130
15	DRAIN HOUSING 3/4"NPT MALE	1	ZB1010
16	NAME LABEL IVUM 4"	1	A2079
20	BASE CODE-RRM ALUMINUM	1	Y4412
21	TILLER BASE CODE-RRM ALUMINUM	1	Y4413
22	FLANGE 4"ANSI X CODE-RRM MODIFIED	1	A2080
23	O-RING-250	1	VO-250
30	ADAPTER CODE-RRM X VUM OUTLET	1	A2081
31	3/8-16 X 1 SOCKET HEAD SCREW	8	VT37-16SH1.0
32	QUICK CONNECT - VUM X 4.5"NHM	1	Y4484
33	OUTLET VUM CODE-RPM	1	A1026
34	OUTLET VUM 22.5 DEGREE CODE-RPM	1	A1040
35	FLANGE VUM FOR SMALL MONITORS	1	Y2433
36	QUICK CONNECT - VUM X 2.5"NHM	1	Y2432A
37	3/16 X 3/8 HDP SPIROL PIN	1	VP188X.38HDP
38	BASE SINGLE LEAD FOR VUM	1	Y2416A
A	HALF BALL	1	SEE SECTION 6.3/6.4
B	SECONDARY POSITION INDICATOR	1	SEE SECTION 6.5/6.6
C	WORM GEARBOX	1	SEE SECTION 6.7/6.8

6.3 HALF BALL [A] EXPLODED VIEWS

MODEL ZAAZ* -- ALUMINUM
HALF BALL WITHOUT DRAIN

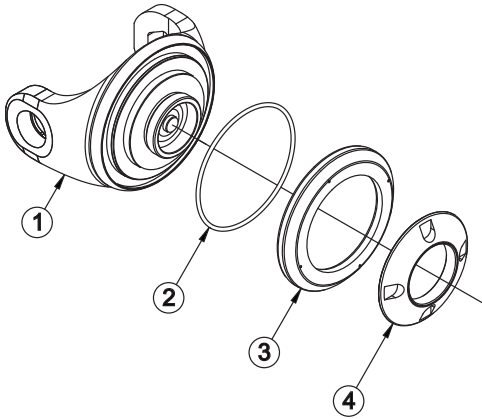

MODEL ZAAD* -- ALUMINUM
HALF BALL WITH INTERNAL DRAIN

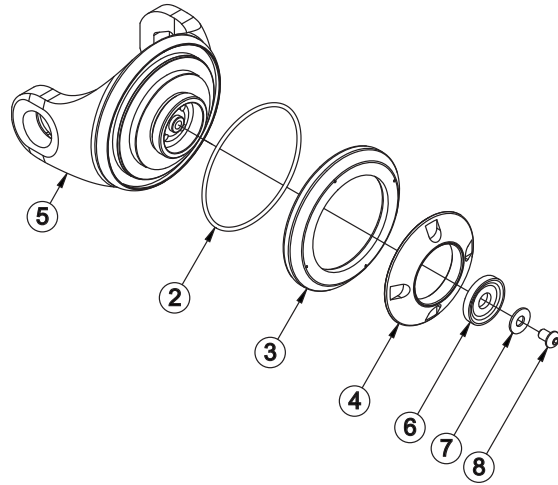

MODEL ZASZ* -- STAINLESS STEEL
HALF BALL WITHOUT DRAIN

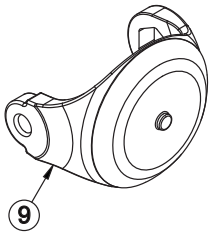

MODEL ZASD* -- STAINLESS STEEL
HALF BALL WITH INTERNAL DRAIN

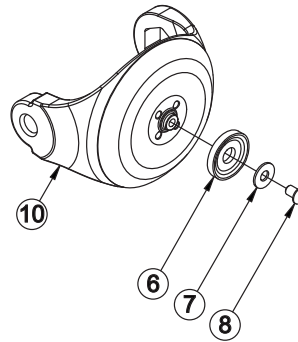

6.4 HALF BALL [A] PARTS LIST

INDEX	DESCRIPTION	QTY	PART #
1	4" HALF BALL ALUM	1	A2090
2	O-RING-237	1	VO-237
3	SPHERICAL SEAT INSERT 4"	1	A2091
4	SPHERICAL SEAT RETAINER 4"	1	A2092
5	4" HALF BALL WITH DRAIN ALUM	1	A2093
6	DRAIN VALVE	1	X382
7	FLAT WASHER 1/4"	1	VW687X281-50
8	1/4-20 X 3/8 BUTTON HEAD SCREW	1	VT25-20BH375
9	HALF BALL 5.5"DIA STAINLESS	1	A1043S
10	HALF BALL SELF-DRAIN 5.5"DIA STAINLESS	1	A1028S

6.5 SECONDARY POSITION INDICATOR [B] EXPLODED VIEW

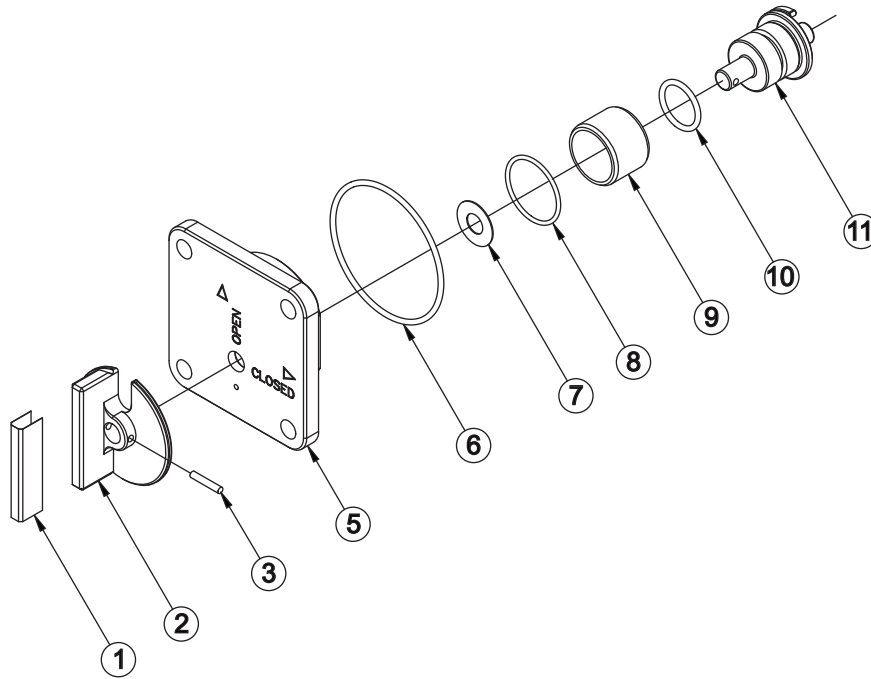

6.6 SECONDARY POSITION INDICATOR [B] PARTS LIST

INDEX	DESCRIPTION	QTY	PART #
1	POSITION INDICATOR LABEL	1	A1524
2	POSITION INDICATOR WITH FLAG	1	A1523
3	5/32 X 7/8 HDP SPIROL PIN	1	V1900
5	TRUNNION GUIDE	1	A2075
6	O-RING-236	1	VO-236
7	GEAR THRUST WASHER	1	A1502
8	O-RING-128	1	VO-128
9	LOWER TRUNNION BUSHING	1	A2074
10	O-RING-214	1	VO-214
11	INDICATOR TRUNNION ALUM	1	A2073A
	INDICATOR TRUNNION STAINLESS		A2073S

6.7 WORM GEARBOX [C] EXPLODED VIEW

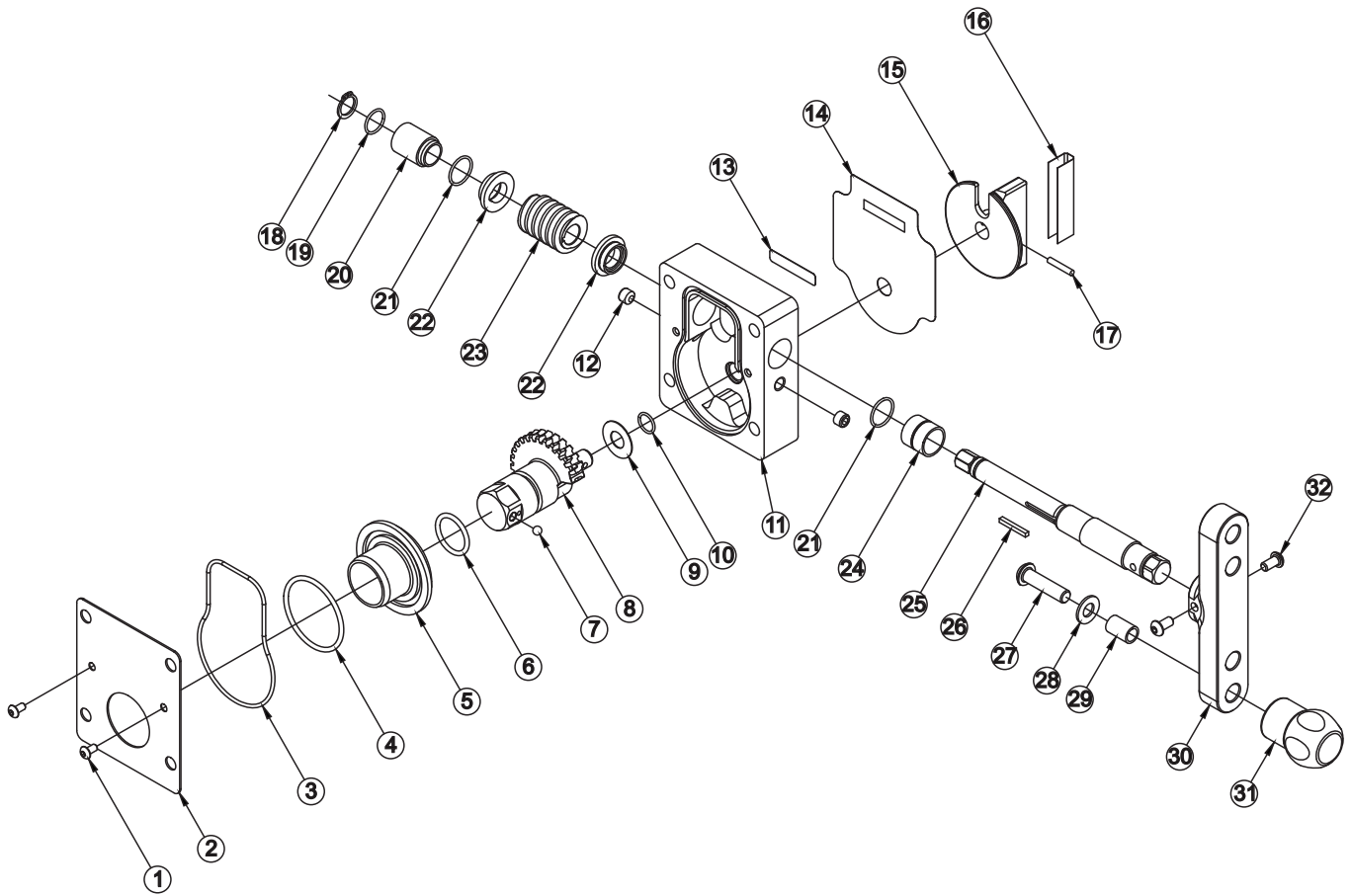

6.8 WORM GEARBOX [C] PARTS LIST

INDEX	DESCRIPTION	QTY	PART #
1	10-24 X 3/8 BUTTON HEAD SCREW	2	VT10-24BH375
2	GEARBOX COVER	1	A1030
3	O-RING-154	1	VO-154
4	O-RING-226	1	VO-226
5	GEAR SPACER	1	A1511
6	O-RING-214	1	VO-214
7	.243" TORLON BALL	1	VB243TO
8	INTEGRAL WORM GEAR & TRUNNION	1	A1501
9	GEAR THRUST WASHER	1	A1502
10	O-RING-014	1	VO-014
11	GEARBOX 250PSI	1	A1506
12	3/8-16 X 5/16 SOCKET SET SCREW	2	VT37-16SS312
13	MODEL NUMBER LABEL	1	A1303
14	NAME LABEL: VUM GEARBOX	1	A1024
15	POSITION INDICATOR	1	A1523
16	POSITION INDICATOR LABEL	1	A1524
17	5/32 X 7/8 HDP SPIROL PIN	1	VP1900
18	RETAINING RING	1	VR4275
19	O-RING-016	1	VO-016
20	LARGE BUSHING FOR SEALED GEARBOX	1	A1528
21	O-RING-018	2	VO-018
22	WORM THRUST WASHER	2	A1529
23	12 DP WORM - DEGREASED	1	X220
24	SMALL BUSHING FOR SEALED GEARBOX	1	A1527
25	SHAFT FOR SEALED GEARBOX	1	A1533
26	KEY	1	X225
27	3/8-16 X 1-1/2 BUTTON HEAD SCREW	1	VT37-16BH1.5
28	WASHER	1	VW812X406-65
29	CRANK BUSHING	1	A1547
30	T-HANDLE CRANK	1	A1534
31	KNOB	1	A1512
32	1/4-20 X 1/2 BUTTON HEAD SCREW	2	VT25-20BH500

7.0 MAINTENANCE AND REPAIRS

The Industrial Valve Under Monitor requires no routine maintenance. The gearbox is sealed and requires no periodic greasing. Valve seats shall be greased as needed with a silicone based grease such as Dow Corning 112. Any scrapes that expose bare aluminum should be cleaned and touched up with enamel paint such as Rust-Oleum. Replace any missing or damaged parts before returning the valve to service.

The valve should be inspected annually and after each use. In particular, check that:

- There are no leaks with the valve off and while flowing.
- Crank handle moves freely between open and closed positions.
- Valve position indicator correctly reflects valve position between open and closed positions.

7.1 CRANKSHAFT OVERRIDE AND REPLACEMENT

The crankshaft includes an intentional shear joint to protect the gear train from overload, costly repairs and loss of service.

The magnitude of torque required to shear the crankshaft is several times greater than the torque typically needed to operate the valve at maximum operating pressure. If the crankshaft breaks during use, this is an indication that either there is something obstructing the half ball internally or the crank shaft has been abused (e.g. used as a step for climbing).

OVERRIDE

In an emergency, the opposite side of the crankshaft can be turned using a 1/2" wrench or hex socket. This allows the valve to be open or closed until the crankshaft is replaced. To prevent loss of the 1/8" square key on the crankshaft, do not allow the crankshaft to slide out of gearbox until a replacement crankshaft is acquired. It is important not to rely on this as a long-term method of operation.

DIAGNOSIS

To diagnose the problem that caused the crankshaft to fail, complete the following steps:

1. Close upstream water supply. If possible, relieve pressure leading up to valve.
2. Locate 1/2" hex where crankshaft protrudes from opposite side of gearbox.
3. Gently turn crank shaft away from travel stop using a 1/2" hex wrench. Do not attempt to shock crankshaft free and do not exceed 50 ft-lb (68 Nm) of torque.
4. If crankshaft will not rotate, then half ball is likely obstructed. Only after relieving pressure on flanged joint, unbolt valve. Clear any obstructions and evaluate whether repair is needed before returning to service.
5. If crankshaft is able to rotate, cycle the valve several times from open to closed to determine whether the crankshaft binds at any place between the travel stops. If crankshaft binds, consult Task Force Tips Service Department to determine the appropriate repairs.
6. If crankshaft rotates freely after clearing any obstructions, then a replacement crank shaft may be ordered from Task Force Tips and replaced as described below.

REPLACEMENT

A broken crankshaft can be replaced at any time by completing the following steps, regardless of whether or not the upstream water supply is pressurized. Referring to index numbers shown in sections 6.7 and 6.8, follow the steps below:

1. Remove external retaining ring (index 16) adjacent to 1/2" hex on crankshaft.
2. Using a punch or Phillips head screwdriver at least 6" in length, gently push on dimple in 1/2" hex end of crankshaft (index 23). Continue to push crankshaft through until it protrudes from opposite side of gearbox.
3. Grab broken end of crankshaft and pull out of gearbox. As crankshaft is withdrawn, grasp small key (index 24) on shaft so it does not get lost.
4. If 1/8" square x 1" long key is not visible in shaft, it has likely fallen into gearbox bore and must be removed before installing new crankshaft. If square key is visible in gearbox bore, slide it out of bore. Needle-nose pliers may be helpful depending on position of key in bore.
5. Verify polymer bushings (index 22 and 18) are still seated in bores on each side of gearbox. If not, locate and replace bushings.
6. Look through gearbox bore and note approximate orientation of square keyway in worm (index 21). Verify round notch in thrust washer (index 20) is aligned with square keyway in worm.
7. Prepare new crankshaft by applying small dab of grease to keyway and seating 1/8" square x 1" long key into keyway. Grease will keep key in place during assembly.
8. Slide shaft into gearbox with key orientation the same as keyway in worm. Rotate shaft slightly in alternating directions until key finds keyway, then push shaft in until it stops. Retaining ring groove and 1/2" hex should be protruding through opposite side of gearbox. If hex is not visible, it may be necessary to slide polymer bushing back into gearbox bore.
9. Install retaining ring (index 16) onto shaft. Do not over-expand the retaining ring.

7.2 VALVE SEAT REPLACEMENT

The valve seat may be replaced in the field if it becomes a source of leakage due to harsh environmental conditions or excessive age. A ½” drive spanner wrench for the valve seat retainer may be purchased from Task Force Tips.

Referring to index numbers shown in sections 6.1 and 6.2, follow the steps below:

1. Close upstream water supply and relieve pressure leading up to valve.
2. After relieving pressure on the inlet flanged joint, unbolt inlet flange of valve).
3. Using ½” drive spanner wrench, remove valve seat retainer (index 2). Remove o-ring (index 1) from valve seat retainer.
4. Using pliers, pull old valve seat (index 4) out of groove in valve body.
5. Clean sealing surfaces of half ball (index A), valve body (index 6), flange (index 3) and valve seat retainer. Also clean all debris from threads of valve seat retainer and flange. Verify all sealing surfaces are smooth and intact. If significant damage is visible, consult Task Force Tips Service Department.
6. Apply light coat of silicone based grease such as Dow Corning 112 to all sealing surfaces and threads of half ball, valve body, and valve seat retainer. Open valve so half ball is out of the way.
7. Install new valve seat (index 4) into groove in valve body with wider side facing the half ball. Slide a pick laterally between female thread and valve seat to verify entire circumference of valve seat is seated in groove.
8. Install new o-ring (index 1) over valve seat retainer. Apply grease over o-ring.
9. Install valve seat retainer into flange until it is snug against the valve seat.
10. Reinstall valve on flange according to instructions in section 4.0. If valve leaks through valve seat, try tightening the valve seat retainer slightly more.

8.0 PRESSURE LOSS

The flow coefficient and graph below apply to all models of the 4” Industrial Valve Under Monitor. Data shown is for valve only and does not include monitor or nozzle pressure losses.

The Cv flow coefficient is calculated according to the formula :

Where Cv = flow coefficient, Q = flow rate in gpm and ΔP = pressure loss in psi across valve (applies for water only).

$$C_v = \frac{Q}{\sqrt{\Delta P}}$$

For the 4” Industrial Valve under monitor, $C_v = 815$

$$\Delta P = \frac{Q^2}{C_v^2}$$

To calculate pressure loss for a given flow rate, this formula can be rearranged as:

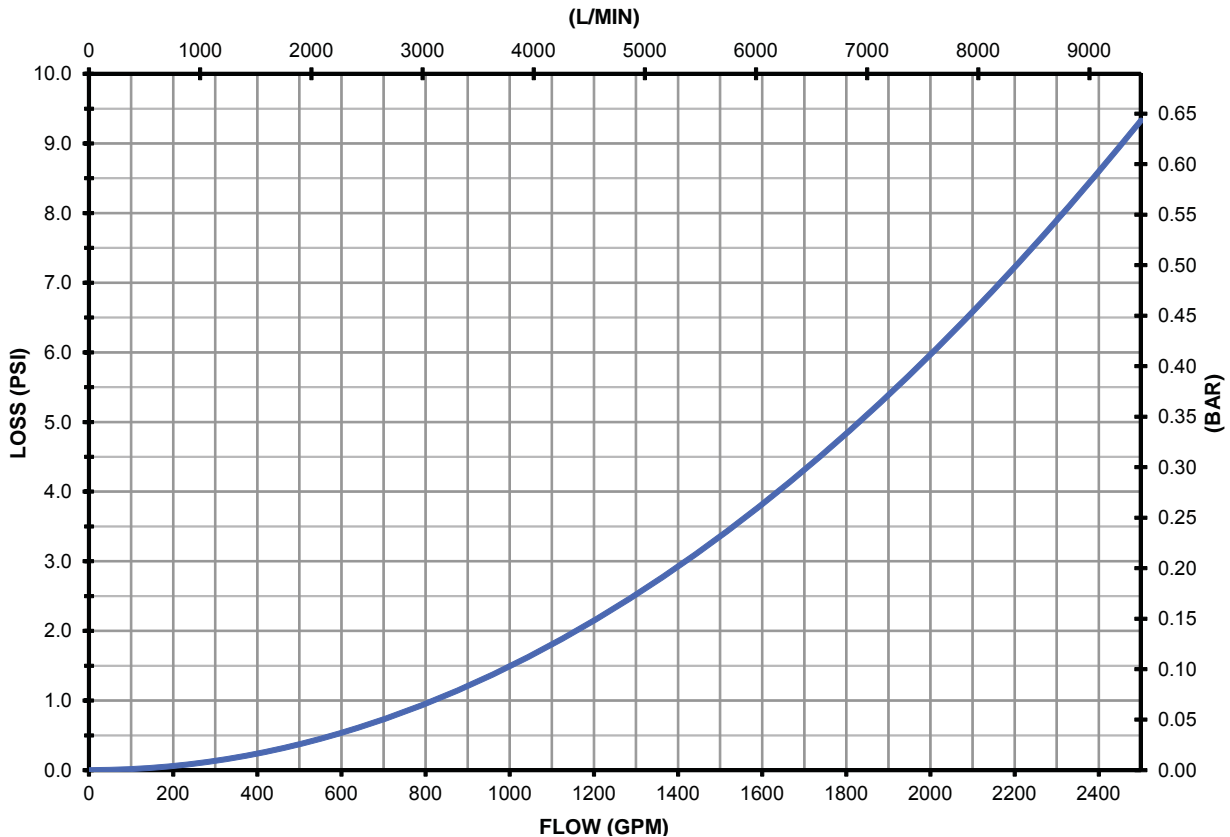

9.0 WARRANTY

Task Force Tips, Inc., 3701 Innovation Way, Valparaiso, Indiana 46383-9327 ("TFT") warrants to the original purchaser of its Industrial Valve Under Monitor ("equipment"), and to anyone to whom it is transferred, that the equipment shall be free from defects in material and workmanship during the five (5) year period from the date of purchase.

TFT's obligation under this warranty is specifically limited to replacing or repairing the equipment (or its parts) which are shown by TFT's examination to be in a defective condition attributable to TFT. To qualify for this limited warranty, the claimant must return the equipment to TFT, at 3701 Innovation Way, Valparaiso, Indiana 46383-9327, within a reasonable time after discovery of the defect. TFT will examine the equipment. If TFT determines that there is a defect attributable to it, TFT will correct the problem within a reasonable time. If the equipment is covered by this limited warranty, TFT will assume the expenses of repair.

If any defect attributable to TFT under this limited warranty cannot be reasonably cured by repair or replacement, TFT may elect to refund the purchase price of the equipment, less reasonable depreciation, in complete discharge of its obligations under this limited warranty. If TFT makes this election, claimant shall return the equipment to TFT free and clear of any liens and encumbrances.

This is a limited warranty. The original purchaser of the equipment, any person to whom it is transferred, and any person who is an intended or unintended beneficiary of the equipment, shall not be entitled to recover from TFT any consequential or incidental damages for injury to person and/or property resulting from any defective equipment manufactured or assembled by TFT. It is agreed and understood that the price stated for the equipment is in part consideration for limiting TFT's liability. Some states do not allow the exclusion or limitation of incidental or consequential damages, so the above may not apply to you.

TFT shall have no obligation under this limited warranty if the equipment is, or has been, misused or neglected (including failure to provide reasonable maintenance) or if there have been accidents to the equipment or if it has been repaired or altered by someone else.

THIS IS A LIMITED EXPRESS WARRANTY ONLY. TFT EXPRESSLY DISCLAIMS WITH RESPECT TO THE EQUIPMENT ALL IMPLIED WARRANTIES OF MERCHANTABILITY AND ALL IMPLIED WARRANTIES OF FITNESS FOR A PARTICULAR PURPOSE. THERE IS NO WARRANTY OF ANY NATURE MADE BY TFT BEYOND THAT STATED IN THIS DOCUMENT.

This limited warranty gives you specific legal rights, and you may also have other rights which vary from state to state.

10.0 ANSWERS TO YOUR QUESTIONS

We appreciate the opportunity of serving you and making your job easier. If you have any problems or questions, our toll-free "Hydraulics Hotline", 800-348-2686, is normally available to you 24 hours a day, 7 days a week.