



MANUAL: Remote Control (RC) Monitor Electrical Controls

Supplemental Instructions for use with RC Monitor Manual

INSTRUCTIONS FOR INSTALLATION, SAFE OPERATION AND MAINTENANCE

⚠ DANGER

Read instruction manual before use. Operation of this device without understanding the manual and receiving proper training is a misuse of this equipment. A person who has not read and understood all operating and safety instructions is not qualified to operate a TFT RC Monitor.

SECTION 1.0

General Information and Specifications

SECTION 2.0

Electrical Controls Installation and Operation

SECTION 2.1

Monitor Mounted
Operator Station

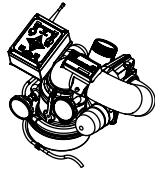

SECTION 2.2

Panel Mount
Operator Station
(Y4E-RP)



SECTION 2.3

Tethered
Operator Station
(Y4E-CT-##)

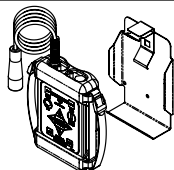

SECTION 2.4

Wireless
Operator Station
(YE-RF-##)

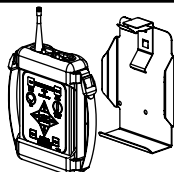

SECTION 2.5

Joystick
Operator Station
(Y4E-JS)

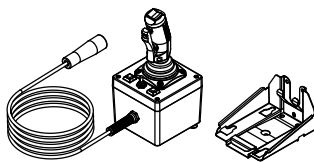

SECTION 2.6

Toggle Switch
Operator Station
(Y4E-TS)

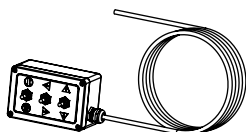

SECTION 2.7

Monitor Communication
Interface Control
(Y4E-COMM)

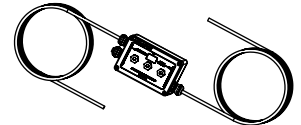

SECTION 2.8

Monitor Position Display
(Y4E-DISP)

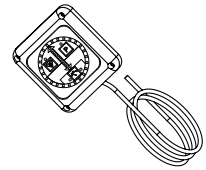

SECTION 2.9

Remote Auxiliary Function
Interface Control
(YE-REMAUX)

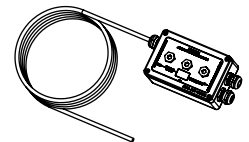

SECTION 2.10

Aerial (Ladder & Platform)
Controls

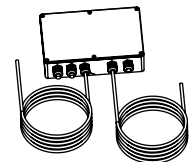

SECTION 2.11

Multiplex Interface Control (YE-CAN#)

SECTION 2.12

Electric Nozzle Actuator

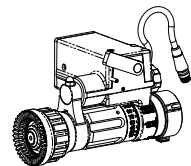

SECTION 2.13

Valve Kit
(YE-VK-PH)

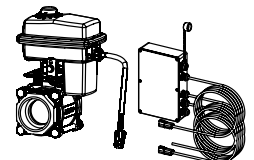

SECTION 3.0

Troubleshooting

TASK FORCE TIPS, INC.
MADE IN USA • www.tft.com

3701 Innovation Way, IN 46383-9327 USA
800-348-2686 • 219-462-6161 • Fax 219-464-7155

Table Of Contents

<p>1.0 General Information and Specifications3-4</p> <p>1.1 Electrical Specifications</p> <p>1.2 Electrical Controls</p> <p style="padding-left: 20px;">1.2.1 Motor Control Board (MCB) Auto Configure</p> <p style="padding-left: 20px;">1.2.2 Motor Current Limiting</p> <p style="padding-left: 20px;">1.2.3 Motor Soft Stops</p> <p style="padding-left: 20px;">1.2.4 Motor Slow/Fast Speed</p> <p style="padding-left: 20px;">1.2.5 Communication Protocol</p> <p style="padding-left: 20px;">1.2.6 Oscillate and Park Features</p> <p style="padding-left: 20px;">1.2.7 Smart Stream Technology</p> <p style="padding-left: 20px;">1.2.8 Monitor Disable Interlock</p> <p>2.0 Electrical Controls Installation and Operation 5</p> <p>2.0.1 Operator Stations</p> <p>2.0.2 Setting Up A Master Operating Station</p> <p>2.0.3 Park Feature</p> <p style="padding-left: 20px;">2.0.3.1 Programming</p> <p style="padding-left: 20px;">2.0.3.2 Park Programming Example</p> <p>2.0.4 Oscillate Feature</p> <p style="padding-left: 20px;">2.0.4.1 Programming</p> <p style="padding-left: 20px;">2.0.4.2 Oscillate Pattern Retain Feature (DIP #4)</p> <p>2.0.5 Override Knobs</p> <p>2.1 Monitor Mounted Operator Station 9</p> <p style="padding-left: 20px;">2.1.1 Mounting</p> <p style="padding-left: 20px;">2.1.2 Electrical Wiring</p> <p style="padding-left: 20px;">2.1.3 Connecting Directly to Protected Power Supply</p> <p style="padding-left: 20px;">2.1.4 Operation</p> <p style="padding-left: 20px;">2.1.5 Button Overlay</p> <p>2.2 Panel Mount Operator Station 10</p> <p style="padding-left: 20px;">2.2.1 Mounting</p> <p style="padding-left: 20px;">2.2.2 Electrical Wiring</p> <p style="padding-left: 20px;">2.2.3 Inputs Signal Configuration</p> <p style="padding-left: 20px;">2.2.4 Panel Mount Operator Station With AT PARK Relay</p> <p style="padding-left: 20px;">2.2.5 Operation</p> <p>2.3 Tethered Operator Station 13</p> <p style="padding-left: 20px;">2.3.1 Mounting Storage Bracket</p> <p style="padding-left: 20px;">2.3.2 Receptacle Mounting</p> <p style="padding-left: 20px;">2.3.3 Electrical Wiring</p> <p style="padding-left: 20px;">2.3.4 Operation</p> <p>2.4 Wireless Operator Station 15</p> <p style="padding-left: 20px;">2.4.1 Mounting Storage Bracket</p> <p style="padding-left: 20px;">2.4.2 Installing Radio/Antenna</p> <p style="padding-left: 20px;">2.4.3 Teaching ID Code</p> <p style="padding-left: 20px;">2.4.4 Changing Batteries</p> <p style="padding-left: 20px;">2.4.5 Operation</p>	<p>2.5 Joystick Operator Station 18</p> <p style="padding-left: 20px;">2.5.1 Mounting Storage Bracket</p> <p style="padding-left: 20px;">2.5.2 Operation</p> <p>2.6 Toggle Switch Monitor Operator Station 20</p> <p style="padding-left: 20px;">2.6.1 Enclosure Mounting</p> <p style="padding-left: 20px;">2.6.2 Electrical Wiring</p> <p style="padding-left: 20px;">2.6.3 Operation</p> <p>2.7 Communication Interface Control 21</p> <p style="padding-left: 20px;">2.7.1 Enclosure Mounting</p> <p style="padding-left: 20px;">2.7.2 Electrical Wiring</p> <p style="padding-left: 20px;">2.7.3 Inputs Signal Configuration</p> <p style="padding-left: 20px;">2.7.4 Communication Interface Box With AT PARK Relay</p> <p>2.8 Monitor Position Display 22</p> <p style="padding-left: 20px;">2.8.1 Enclosure Mounting</p> <p style="padding-left: 20px;">2.8.2 Electrical Wiring</p> <p style="padding-left: 20px;">2.8.3 Programming Display</p> <p>2.9 Remote AUXiliary Interface Control 24</p> <p style="padding-left: 20px;">2.9.1 Enclosure Mounting</p> <p style="padding-left: 20px;">2.9.2 Electrical Wiring</p> <p style="padding-left: 20px;">2.9.3 Configuration</p> <p>2.10 Electrical RC Monitor Aerial Truck Installation 25</p> <p>2.10.1 Electronics Enclosure Mounting</p> <p style="padding-left: 20px;">2.10.2 Electrical Wiring</p> <p style="padding-left: 40px;">2.10.2.1 Ladder Installation Electrical Wiring</p> <p style="padding-left: 40px;">2.10.2.2 Platform Installation Electrical Wiring</p> <p style="padding-left: 20px;">2.10.3 Electrical Enclosure With AT PARK Relay</p> <p style="padding-left: 40px;">2.10.3.1 Electric Connections</p> <p>2.11 Multiplex Interface Control (YE-CAN#) 28</p> <p>2.12 Electric Nozzle Actuator 29</p> <p style="padding-left: 20px;">2.12.1 Wiring</p> <p style="padding-left: 20px;">2.12.2 Operation of Flush, Fog, Stream</p> <p>2.13 Valve Kits 30</p> <p style="padding-left: 20px;">2.13.1 Valve Mounting</p> <p style="padding-left: 20px;">2.13.2 Interface Enclosure Mounting</p> <p style="padding-left: 20px;">2.13.3 Electrical Wiring</p> <p style="padding-left: 20px;">2.13.4 Configuration</p> <p>3.0 Troubleshooting 31</p>
--	---

MEANING OF SAFETY SIGNAL WORDS

A safety related message is identified by a safety alert symbol and a signal word to indicate the level of risk involved with a particular hazard. Per ANSI standard Z535.6-2006, the definitions of the four signal words are as follows:



DANGER indicates a hazardous situation which, if not avoided, will result in death or serious injury.



WARNING indicates a hazardous situation which, if not avoided, could result in death or serious injury.



CAUTION indicates a potentially hazardous situation which, if not avoided, may result in minor or moderate injury.



NOTICE is used to address practices not related to personal injury.

SAFETY



The electric motors and other components are ignition sources. The electric drives should be operated only in areas where there is adequate ventilation and no hazard of flammable vapor buildup.



Disconnect power before installing or servicing the monitor to avoid electrical shock or injury from moving parts.



PERSONAL RESPONSIBILITY CODE

The member companies of FEMSA that provide emergency response equipment and services want responders to know and understand the following:

1. Firefighting and Emergency Response are inherently dangerous activities requiring proper training in their hazards and the use of extreme caution at all times.
2. It is your responsibility to read and understand any user's instructions, including purpose and limitations, provided with any piece of equipment you may be called upon to use.
3. It is your responsibility to know that you have been properly trained in Firefighting and /or Emergency Response and in the use, precautions, and care of any equipment you may be called upon to use.
4. It is your responsibility to be in proper physical condition and to maintain the personal skill level required to operate any equipment you may be called upon to use.
5. It is your responsibility to know that your equipment is in operable condition and has been maintained in accordance with the manufacturer's instructions.
6. Failure to follow these guidelines may result in death, burns or other severe injury.



Fire and Emergency Manufacturers and Service Association
P.O. Box 147, Lynnfield, MA 01940 • www.FEMSA.org

1.0 GENERAL INFORMATION AND SPECIFICATIONS

1.1 ELECTRICAL SPECIFICATIONS

Nominal operating voltage:	12 or 24 VDC (auto sense)			
Motor current:	Nominal*		Limit	
	@ 12 VDC	@24 VDC	@ 12 VDC	@24 VDC
Elevation motor:	6 amps	3 amps	15 amps	7.5 amps
Horizontal rotation motor:	6 amps	3 amps	10 amps	5 amps
Nozzle motor:	1 amp	0.5 amps	5 amps	2.5 amps
	*with rated water pressure applied			
At rest current:	.25 amps @ 12 VDC			
Recommended fuse or circuit breaker size:	15 amps @ 12 volts, 7.5 amps @ 24 volts			
Operating temperature range:	-30F to +120F (-34C to +49C)			
Environmental Rating:	All components designed to meet minimum rating of NEMA 4 (IP65).			

WIRELESS OPERATOR STATION (YE-RF-##)

	YE-RF-900, 900 MHz	YE-RF-2400, 2.4 GHz
Handheld Unit Batteries	Four (AA) Batteries, Lithium Recommended	
Transmitting Power	100mW	50mW
Operating Range	500 ft (152m)	
Operating Frequency	900 MHz (902-928 MHz)	2.4GHz (2.4000-2.4835 GHz)
Agency Approvals		
FCC	OUR9XSTREAM	OUR24XSTREAM
Industry Canada (IC)	4214A-9XSTREAM	4214A-12.008
Europe	N/A	ETSI

YE-RF-900 CONTAINS FCC ID: OUR9XSTREAM THE ENCLOSED DEVICE COMPLIES WITH PART 15 OF THE FCC RULES. OPERATION IS SUBJECT TO THE FOLLOWING TWO CONDITIONS: (1) THIS DEVICE MAY NOT CAUSE HARMFUL INTERFERENCE AND (2) THIS DEVICE MUST ACCEPT ANY INTERFERENCE RECEIVED, INCLUDING INTERFERENCE THAT MAY CAUSE UNDESIRE OPERATION.

YE-RF-2400 CONTAINS FCC ID: OUR24XSTREAM THE ENCLOSED DEVICE COMPLIES WITH PART 15 OF THE FCC RULES. OPERATION IS SUBJECT TO THE FOLLOWING TWO CONDITIONS: (1) THIS DEVICE MAY NOT CAUSE HARMFUL INTERFERENCE AND (2) THIS DEVICE MUST ACCEPT ANY INTERFERENCE RECEIVED, INCLUDING INTERFERENCE THAT MAY CAUSE UNDESIRE OPERATION.

1.2 ELECTRICAL CONTROLS

The electric TFT RC monitor is controlled by a very powerful, state-of-the-art electronics system. The key components of the system are the motor control boards and a communication board. Each motor control board has its own microprocessor and a sophisticated motor control chip. The communication board also has a microprocessor, which handles the interface to the operator stations. All the components on these boards are solid state; there are no relays or electromechanical devices to wear out over time. The hardware and software have been designed with several key features:

1.2.1 MOTOR CONTROL BOARD (MCB) AUTO CONFIGURE

Each monitor has three MCBs, one for each motor. The MCB controls motor movement and direction for horizontal rotation, elevation, and nozzle pattern. In the unlikely event of a MCB failure, the failed board can be removed and one of the other two remaining MCBs can be moved into that position. This MCB will then auto configure itself to take over the control of that axis, so that the monitor can continue to be used, with two of the three motors. This is also a helpful benefit when troubleshooting and requires fewer spare parts to be stocked.

1.2.2 MOTOR CURRENT LIMITING

The microprocessor on the MCB continuously monitors the motor current. As the motor reaches an end stop or if there is an obstruction, the motor current rises very quickly and the motor control chip automatically shuts down the motor in a few milliseconds. This eliminates the need for any type of external limit switches and the associated wiring. The microprocessor also locks the operator from moving in the stopped direction again, until the operator first moves in the opposite direction.

1.2.3 MOTOR SOFT STOPS

The horizontal and vertical motors are equipped with feedback encoders which allow the microprocessor to know the motor position at all times. The first time a motor reaches an end stop or strikes an obstruction, the microprocessor sets a new soft stop position just before the end stop. From that point on, when the axis approaches the stop, the MCB automatically slows down the motor until the end stop is reached. This significantly reduces the wear on the motor, gearbox, and gear drives.

1.2.4 MOTOR SLOW/FAST SPEED

When an operator presses one of the buttons, the associated motor starts in low speed mode for accurate control of the water stream. For Tornado Monitors, after approximately ½ second the motor automatically ramps up to high speed, for quickly moving into position. For all other monitors, the speed ramps up after 2 seconds. When quickly changing directions, monitor remains at speed of prior move. If low speed is selected, monitor does not ramp to high speed but remains in low speed.

1.2.5 COMMUNICATION PROTOCOL

The communication from the monitor to the operator stations is performed over two wires using RS-485 serial protocol. Multiple operator stations can be added with only two wires for power and two wires for the RS-485 protocol between each station.

1.2.6 OSCILLATE AND PARK FEATURES

The OSCILLATE feature allows the user to program up to 65 points of continuous movement of the horizontal and vertical axes. The OSCILLATE pattern can be programmed from any operator station that has the OSC button.

The PARK feature allows the user to move the monitor, with one touch of a button, to a safe position before moving the fire truck. The monitor will always move to two end stops to verify the correct position. During the programming procedure, the user has the ability to select which axis moves first. This is helpful to avoid lights, hoses, obstructions, etc. The user can program up to 10 points of movement to reach the final park position. The PARK pattern can be programmed from any operator station that has low profile keypad buttons. A relay contact is available for connection to the truck alarm

1.2.7 SMART STREAM TECHNOLOGY

This technology, only available with TFT RC nozzles, utilizes a position encoder in the nozzle actuator to give the user greater control on the stream pattern, especially at FOG position. Nozzles equipped with a FLUSH position are programmed to stop and pause at full FOG position when moving towards the FLUSH position, preventing unwanted water flow. A second press on the button will cause the nozzle shaper to continue to move to FLUSH position for removing debris from the nozzle.

1.2.8 MONITOR DISABLE INTERLOCK

This feature, only available with TFT RC Extend-A-Guns, provides an interlock for RC monitors that are installed on trucks in extremely confined spaces. TFT RC Extend-A-Guns with the Monitor Disable Interlock feature enabled prevents the monitor from moving when the RC Extend-A-Gun is in the retracted position. This will prevent the monitor from damaging the apparatus that the monitor is installed on and prevent operator error from causing costly damage.

IMPORTANT Review these sections and decide on locations before starting installation process.

2.0 Electrical Controls Installation

2.1 Monitor Mounted Operator Station

2.2 Panel Mount Operator Station (Y4E-RP)

2.3 Tethered Operator Station (Y4E-CT-##)

2.4 Wireless Operator Station (YE-RF-##)

2.5 Joystick Operator Station (Y4E-JS)

2.6 Toggle Switch Operator Station (Y4E-TS)

2.7 Communication Interface Control (Y4E-COMM)

2.8 Monitor Position Display (Y4E-DISP)

2.9 Remote Auxiliary Function Interface Control (YE-REMAUX)

2.10 Aerial (Ladder & Platform) Controls

2.11 Multiplex Interface Control (YE-CAN#)

2.12 Electric Nozzle Actuator

2.13 Valve Kit (YE-VK-PH)

2.0 ELECTRICAL CONTROLS INSTALLATION AND OPERATION

The electric RC monitor is supplied with a monitor mounted operator station. The wiring on the monitor and for this operator station is factory installed. The assembly is supplied with a cable for connection to the operator control stations as shown in Figure 2.0 or directly to a protected voltage supply. This cable has 4-conductors which supply power and the communications from the operator stations to the monitor. To complete the installation, the installer will need to mount and wire the selected operator stations. The power supply for the monitor will need to be connected to a protected circuit from the truck's power distribution center. Refer to the specifications section 1.1 for nominal current draw.

For installations where the customer would like to turn off the voltage to the monitor independent of the truck master switch, the installer needs to install a SPST (single-pole single-throw) toggle switch. Install this toggle switch in a location that can quickly be accessed before using the RC monitor. The toggle switch needs to be wired between the protected voltage supply and the red wire feeding the RC monitor.

INSTALLATION AND SERVICE PRECAUTIONS

- Disconnect power before installing or servicing the electrical components to avoid electrical shock hazard or injury due to moving parts.
- The RC monitor control boxes and motors are not rated as ignition proof, explosion proof, or intrinsically safe. Install in locations with adequate ventilation and no hazard of flammable vapor buildup.
- Provide adequate power supply for all electrical controls and motors taking into account voltage drops on wiring. See section 1.1 for electrical specifications.
- Careful selection of wiring is critical to avoid excessive voltage drop.
- Good mechanical connections on the wires are absolutely necessary and should be checked periodically. Poor electrical connections can cause power loss to the electric RC monitor and be a fire hazard.
- Be careful to route cables and controls in protected areas away from high heat sources.
- Use grommets whenever wires pass through holes to prevent damage due to snags, abrasions, etc.
- Secure cables close to control box with plastic wire ties or cable clamps to relieve stress on the cables.
- Observe precautions for electrostatic sensitive devices when installing or servicing controls. Touch fingers to bare metal surface before handling control boards to dissipate static electricity.
- Make sure that all control covers and gaskets are restored to their original condition after installation or servicing to maintain weather tight seal.

Recommended Tool List - 11/32" nut driver - Wire cutter/stripper - Terminal crimping tool - Utility knife - 20mm open-end box wrench - 17mm open-end box wrench - 5/32" drill bit - 25/32" drill bit - #2 Phillips screwdriver - Small flat blade screwdriver

IMPORTANT - When mechanical installation and electrical connections are complete, perform the following test to verify voltage supply is adequate and the current limiting feature is functioning.

- 1) Apply power to monitor control box.
- 2) Press LEFT or RIGHT button and hold until monitor reaches its stop position. Continue to hold button down.
- 3) Once movement is stopped, manually turn override knob in opposite direction while continuing to hold button down. If knob can be turned, then voltage supply is adequate. If knob cannot be turned and motor continues to operate, then the voltage supply or wiring is not adequate. Check connections and voltage connection point, rewire if necessary. **NOTE: Override knob will only turn in one direction.**

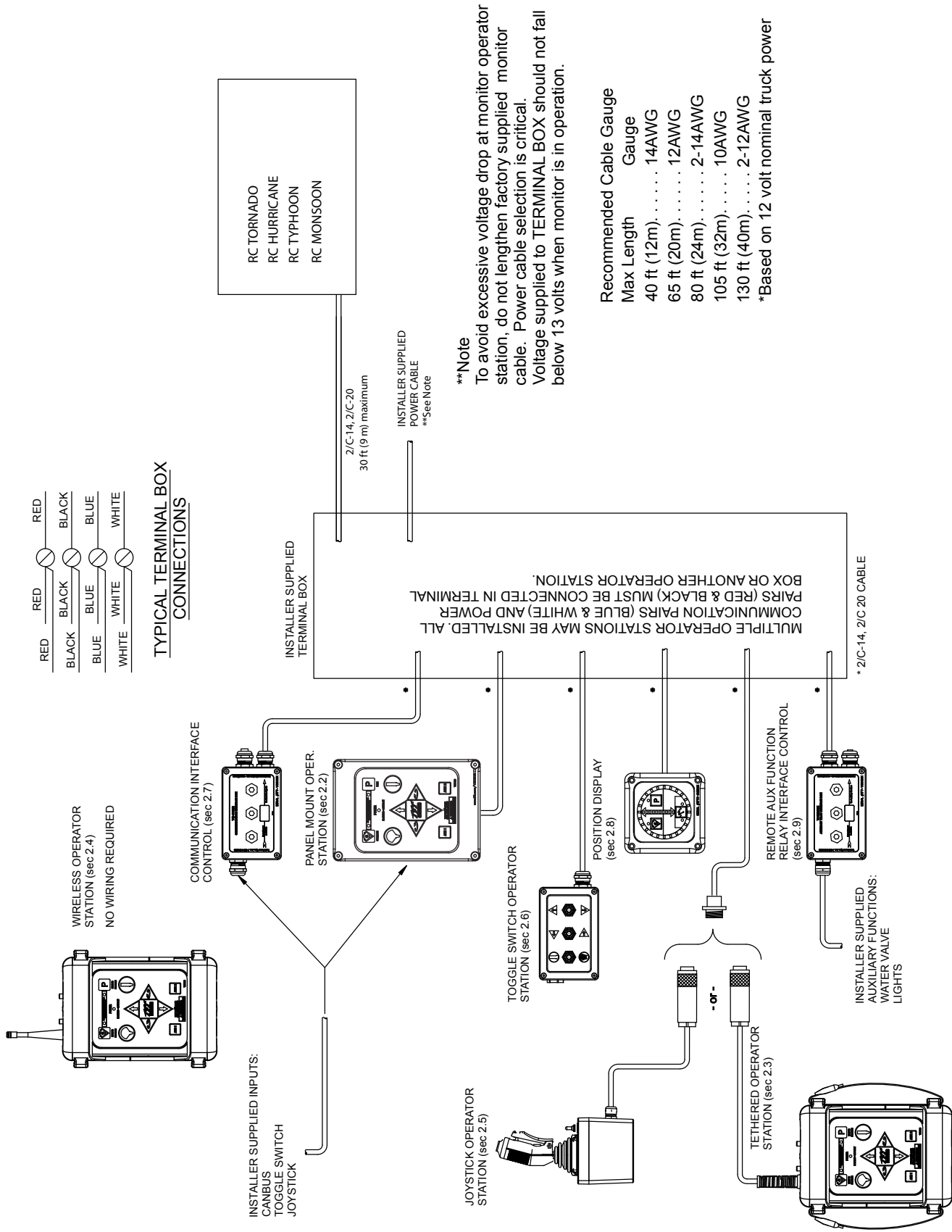

Fig. 2.0
 ELECTRICAL COMPONENTS
 (non-aerial installation)

2.0.1 OPERATOR STATIONS

The electric RC monitor has five different styles of operator stations for use in various locations on the fire truck or fire ground.

The design of the operator station communications allows users to override commands on other stations. The “last” button pressed has control. The overridden user can regain control by releasing his/her button and pressing again.

Platform and ladder electronics enclosures are pre-configured for one set of inputs to have a master override feature. The operator station connected to these inputs, typically at the base of the ladder, will override any other operator station.

Any operator station with a communication board or connected to a communication board can be field configured with the master override feature. This allows the user to setup an operator station on the fire truck or fire ground as the master override station.

2.0.2 SETTING UP A MASTER OPERATING STATION

Any operator station with a communication board can be re-configured to override all other operator stations. These stations include the Y4E-RP, Y4E-CT-30, Y4E-TS, Y4E-JS, YE-RF-## or any inputs connected to an Y4E-COMM. To enable the master override feature on an operator station, follow these steps:

1. Remove lid from enclosure.
2. Locate DIP switches on communication board.
3. Slide DIP switch #1 to the ON position.
4. Replace lid. Verify rubber seal is clean and undamaged. Verify that no wires are caught between lid and box.

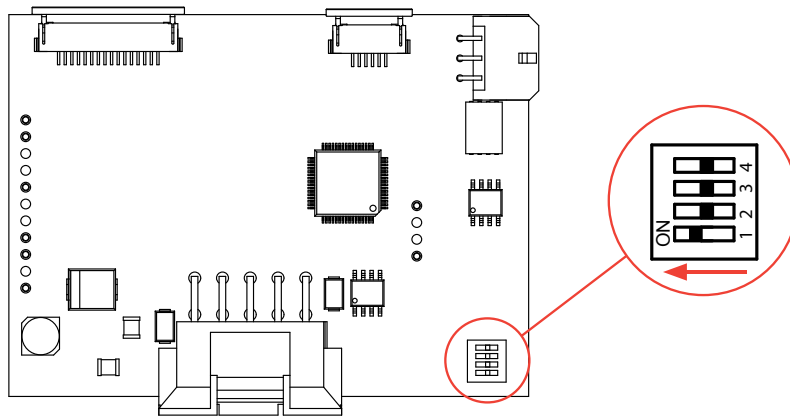

Figure 2.0.2
Master Override Setup

2.0.3 PARK FEATURE

The PARK position needs to be programmed during installation. The monitor needs to “find” two (2) hard stops, one for each axis, before the monitor can move to the PARK position. When programming, the first two commands teach the monitor where to find the hard stops. This guarantees that the position is accurate. From that point, the programmer can program the move to the final PARK position.

During normal operation, each time the PARK button is pressed, the monitor moves the nozzle to the full straight stream position, moves to each programmed hard stop, and then moves to the PARK position. While the monitor is performing the PARK feature, pressing any button will stop the monitor.

RECOMMENDED PARK POSITION: For truck mounted applications, it is recommended that the monitor be parked in a position such that the monitor’s nozzle rests against a bracket or support surface. This will minimize bouncing of the nozzle when the apparatus is traveling. Always be sure the monitor is properly parked before moving the truck and know the overall height to avoid damage from overhead obstructions such as doors or bridges.

2.0.3.1 PROGRAMMING

**PARK PROGRAMMING MUST BE INITIATED
WITHIN 1 MINUTE OF APPLYING POWER TO MONITOR.**

After 1 minute, programming access is blocked. Power must then be cycled to reset 1 minute timer.

Press and hold PARK button (~10 seconds) until light blinks. Release button. Light will continue to blink while in program mode.

FIRST AXIS TO MOVE:

Press and release LEFT/RIGHT or UP/DOWN button of axis that will move to first hard stop. Light will blink rapidly when hard stop is reached.

SECOND AXIS TO MOVE:

Press and release LEFT/RIGHT or UP/DOWN button of axis that will move to second hard stop. Light will blink rapidly when hard stop is reached.

MOVE TO PARK POSITION:

Use LEFT/RIGHT or UP/DOWN buttons to move monitor to first point of park routine, press and release PARK button. Light will blink rapidly to acknowledge position.

Repeat until pattern is complete (up to 10 points).

Press and hold PARK button until light turns off. Release button.

2.0.3.2 PARK PROGRAMMING EXAMPLE

- Press and hold PARK button until light blinks.
- Press and release UP button, monitor will move until hard stop reached. (light blinks rapidly.)
- Press and release RIGHT button, monitor will move until hard stop reached. (light blinks rapidly.)
- Press LEFT button to move 45 degrees, Press and release PARK button. (light blinks rapidly.)
- Press DOWN button to move 90 degrees, Press & release PARK button. (light blinks rapidly.)
- Press and hold PARK button until light turns off.

2.0.4 OSCILLATE FEATURE

The OSCILLATE feature allows the user to program a repeating pattern to control the horizontal and vertical axes of the monitor. While in the OSCILLATE pattern, the monitor will pause while the user changes the stream pattern. Pressing any other button will stop the OSCILLATE pattern.

A label is supplied with each operator station that can be mounted on or near the station as a reminder of how to program the OSCILLATE pattern. The OSCILLATE pattern needs to be programmed before use. The pattern will be cleared each time power is cycled to the monitor. For fixed monitors, the monitor may be configured to store the program permanently. See Section 2.0.4.2.

2.0.4.1 PROGRAMMING

- Move monitor to starting point of pattern.
- Press and hold OSC button (~5 seconds) until light blinks. Release button. Light will continue to blink while in program mode.
- Move monitor to second point, press OSC button. Light will blink rapidly to acknowledge position.
- Repeat until pattern is complete (up to 65 points).
- Press and hold OSC button until light turns off. Release button.

TO OSCILLATE: Press & release OSC button. (Pattern must be programmed first.)	TO PARK: Press & release PARK button. (Programmable, refer to manual.)
--	---

800-348-2686
www.tft.com Y5705

OSCILLATE PATTERN PROGRAMMING:

- 1) Move monitor to starting point of pattern.
- 2) Press & hold OSC button until LED blinks. LED will continue to blink in program mode.
- 3) Move monitor to 2nd point, press OSC button. LED will blink rapidly to acknowledge position.
- 4) Repeat until pattern is complete.
- 5) Press & hold OSC button until LED turns off.

NOTE: PATTERN WILL BE CLEARED UPON POWER LOSS.

Figure 2.0.4.1
Operator Station Label

2.0.4.2 OSCILLATE PATTERN RETAIN FEATURE (DIP #4)

The monitor can be configured so that upon power up, the OSCILLATE pattern is retained. The OSCILLATE pattern must be programmed at least one time (see section 2.0.4.1). To enable the OSCILLATE pattern retain feature follow these steps:

1. Remove lid from monitor operator station.
2. Locate DIP switches on communication board.
3. Slide DIP switch #4 to the ON position.
4. Replace lid. Verify rubber seal is clean and undamaged. Verify that no wires are caught between lid and box.
5. Program OSCILLATE pattern.

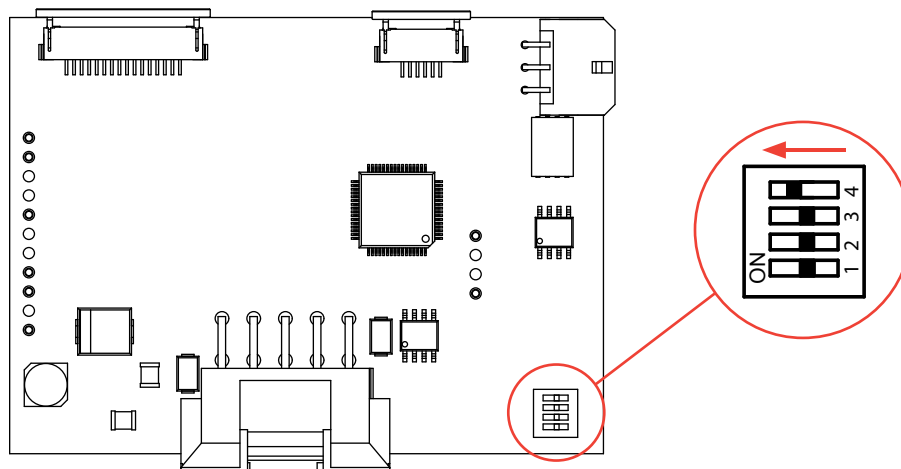
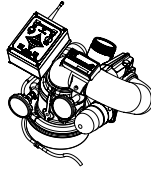

Figure 2.0.4.2
Oscillate Pattern Retain Setup

2.0.5 OVERRIDE KNOBS

In the event of electrical system failure on the monitor or fire apparatus, the TFT RC Monitor is factory supplied with override knobs so the monitor may be manually operated. If desired, the override knobs may be removed. The drive shafts have a hex so a wrench or socket may be used for manual override.

2.1 MONITOR MOUNTED OPERATOR STATION



This operator station is factory installed and wired to the monitor. It allows the monitor to be controlled at the monitor location.

2.1.1 MOUNTING

Operator station is factory installed on the monitor and requires no additional mounting.

2.1.2 ELECTRICAL WIRING

See fig. 2.0 for typical connections. The wiring on the monitor and for this operator station is factory installed. The assembly is supplied with a cable for connection to the other operator control stations. The cable has 4-conductors which supply power and the communications from the operator stations to the monitor.

2.1.3 CONNECTING DIRECTLY TO PROTECTED POWER SUPPLY

The electric RC monitor has an operator station, which is fully functional, mounted on the monitor. If no other operator stations are selected, with the exception of the wireless radio remote, the installer will only need to connect power to complete the installation. Route cable from monitor and connect to a protected circuit from the truck's power distribution center. Connect the red wire to positive and the black wire to negative (ground). Cut and discard blue and white wires.

2.1.4 OPERATION

This operator station is factory installed on the monitor and is used by personnel at the monitor.

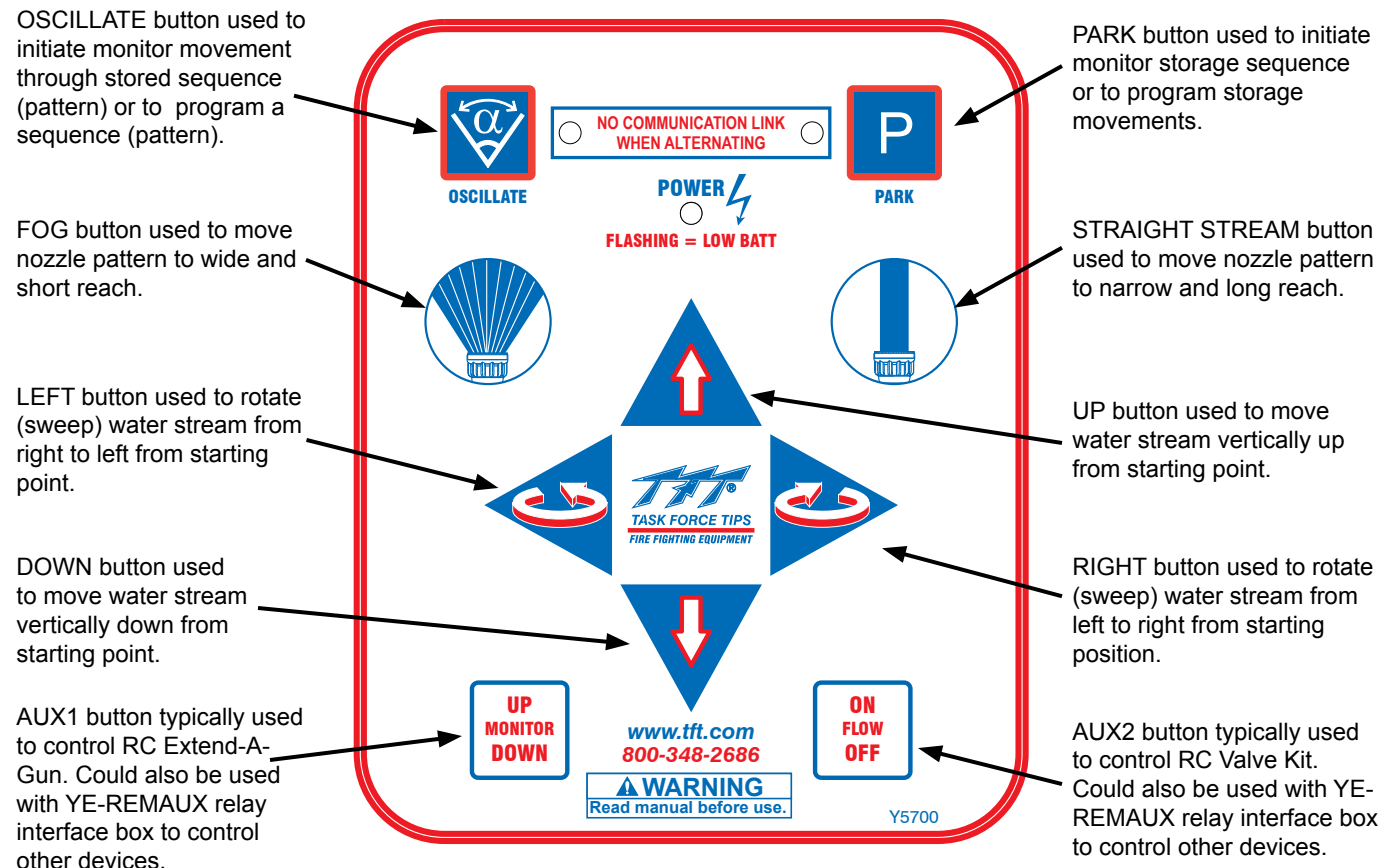

Fig. 2.1.4
Operation Label

2.1.5 BUTTON OVERLAY

Each monitor and operator station is shipped with several button overlays with adhesive that can be used to cover the button text on the lower two buttons. This can be done in applications that do not have either an RC Extend-A-Gun or RC valve kit. If additional overlays are needed, contact the factory.

Clean operator station surface to remove any oils or residues. Carefully peel off overlay and place on top of AUX button, just inside blue border of the button.

2.2 PANEL MOUNT OPERATOR STATION (Y4E-RP)



This operator station allows the monitor to be controlled from a remote location. The installer will need to mount the operator station and connect the cable to the monitor and power. The enclosure is designed to be recess mounted in a panel.

This operator station has extra power and communication terminal blocks available and can be used as a central location for terminating wires. In this type of installation the monitor cable, the power cable, and possibly other operator station cables could be installed into this operator station. On the back of this enclosure are extra strain relief fittings.

In many installations this operator station will also include the wiring connections for the joystick, Canbus output module or installer supplied toggle switches. A terminal block is available for "UP, DOWN, LEFT, RIGHT, FOG, SS, PARK" inputs. The circuit board in this operator station is factory configured to accept ground input signals but can be field changed to accept +12/24 volt DC input signals.

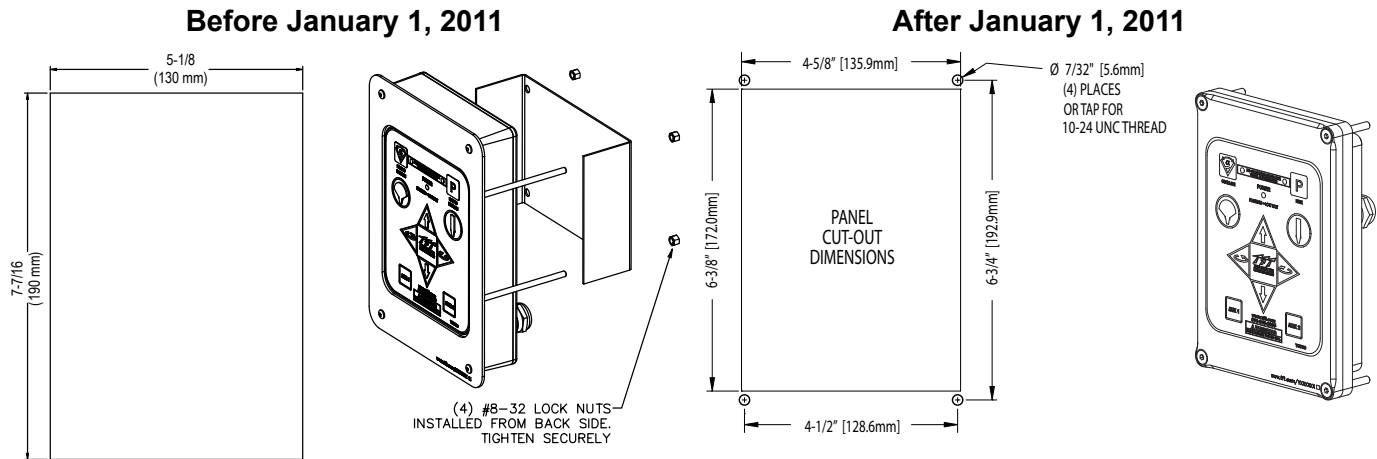

Figure 2.2
Panel Mount Operator Station Cutout Dimensions

2.2.1 MOUNTING

Select proper operator location. Panel space required will be 5" x 7-1/4" (127 x 185mm). A depth of 3/4" (19mm) will be required behind the panel. Additional space will be required where the cables exit the back of the enclosure. Refer to Figure 2.2 for cutout dimensions. Allow at least 6" of slack in cable for future repairs.

2.2.2 ELECTRICAL WIRING

See figure 2.0 for typical connections. The 4-conductor cable from the operator station needs to be connected to power (red & black) and to the communication link (blue & white) from the monitor. Refer to Figure 2.2.2 for typical cable preparation. Be sure to tighten all terminal block screws securely.

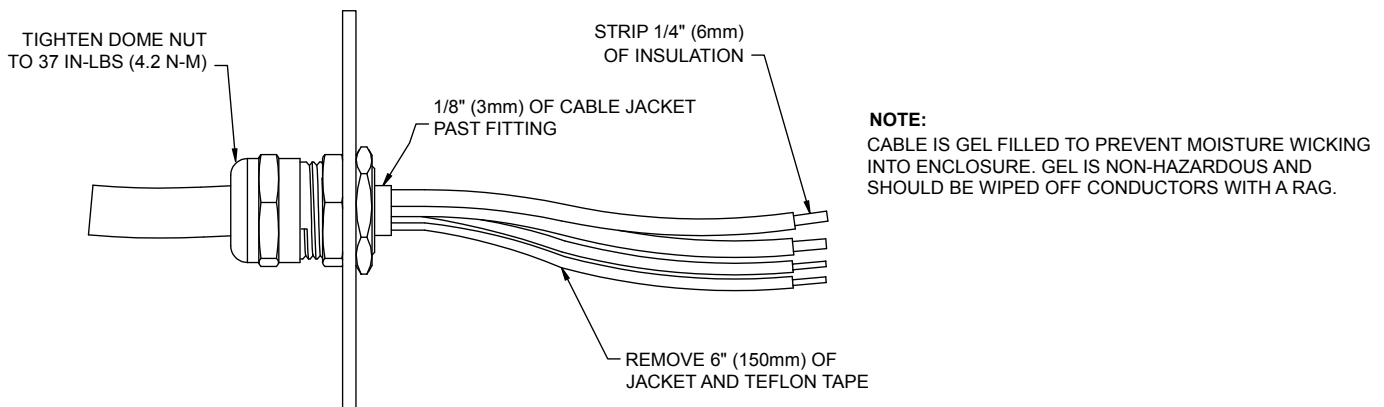

Fig 2.2.2
Typical Cable Preparation

2.2.3 INPUTS SIGNAL CONFIGURATION

The Panel Mount Operator Station is shipped from the factory configured to accept +12/24 volt DC input signals, but can be field changed to accept ground input signals. To change the configuration:

1. Remove lid from enclosure.
2. Locate DIP switches on communication board.
3. Slide DIP switch #4 to the OFF position to select GROUND inputs or slide to the ON position to select VOLTAGE inputs.
4. Replace lid. Verify rubber seal is clean and undamaged. Verify that no wires are caught between lid and box.

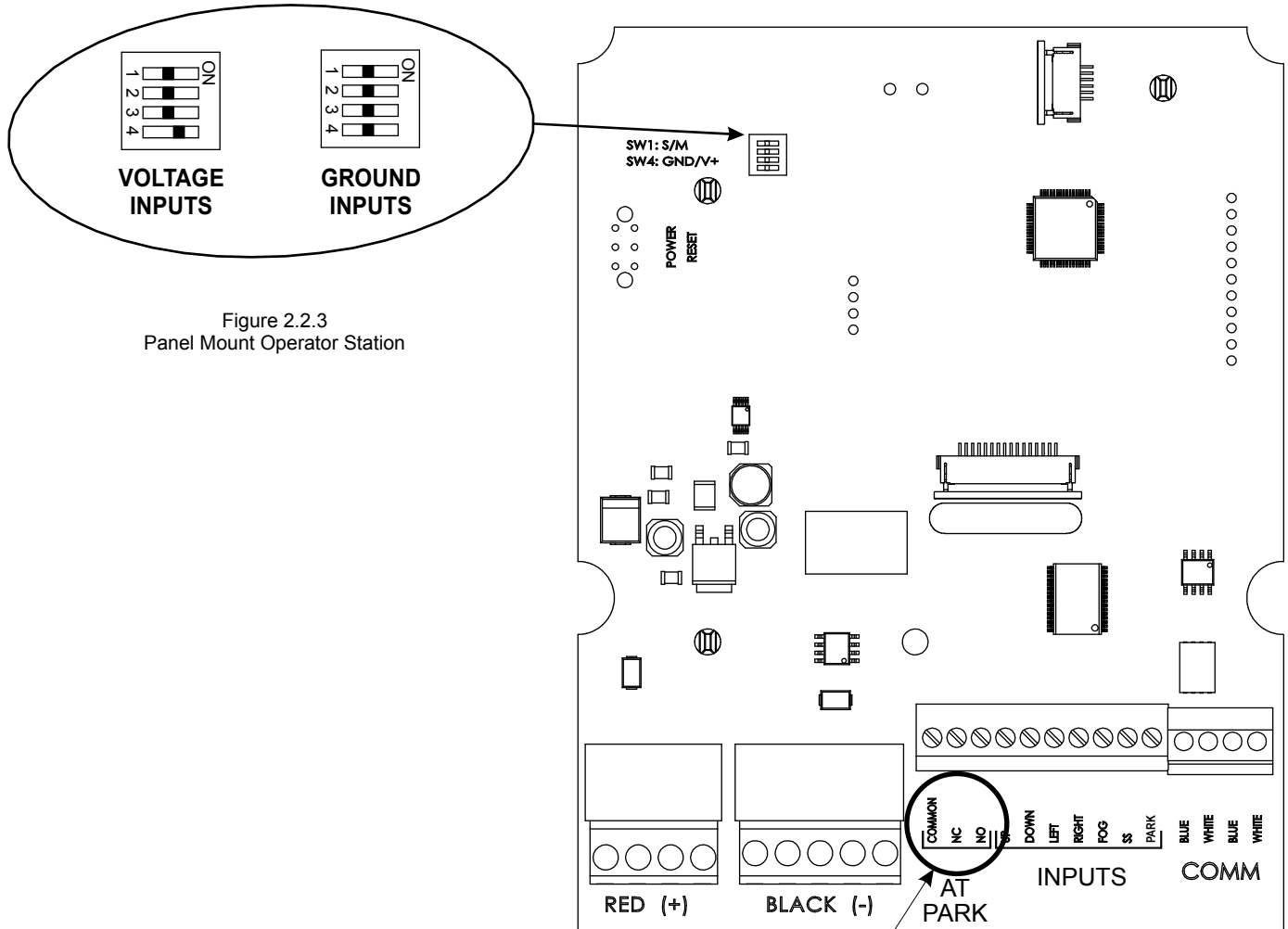

Figure 2.2.3
Panel Mount Operator Station

AT PARK RELAY USER TERMINALS

Figure 2.2.4
Relay / Terminal Location

2.2.4 PANEL MOUNT OPERATOR STATION WITH AT PARK RELAY (Y4E-RP)

The Panel Mount Operator Station provides feedback for the user that the monitor is in the AT PARK position. The Operator station contains a circuit board that is equipped with a relay that is energized when the monitor is in use and de-energized when the monitor reaches its final PARK location. The contact rating of the relay is 1 amp @ 30VDC for resistive loads and 0.2 amps @ 30VDC for inductive loads.

The AT PARK relay has one Form-C contact (common, normally open, normally closed) that can be used. The figure above shows the terminal blocks available for user wiring.

2.2.5 OPERATION

This operator station is installed on the truck, for example the pump operator's panel. It is used to operate the monitor from a location on the truck.

OSCILLATE button used to initiate monitor movement through stored sequence (pattern) or to program a sequence (pattern).

FOG button used to move nozzle pattern to wide and short reach.

LEFT button used to rotate (sweep) water stream from right to left from starting point.

DOWN button used to move water stream vertically down from starting point.

AUX1 button typically used to control RC Extend-A-Gun. Could also be used with YE-REMAUX relay interface box to control other devices.

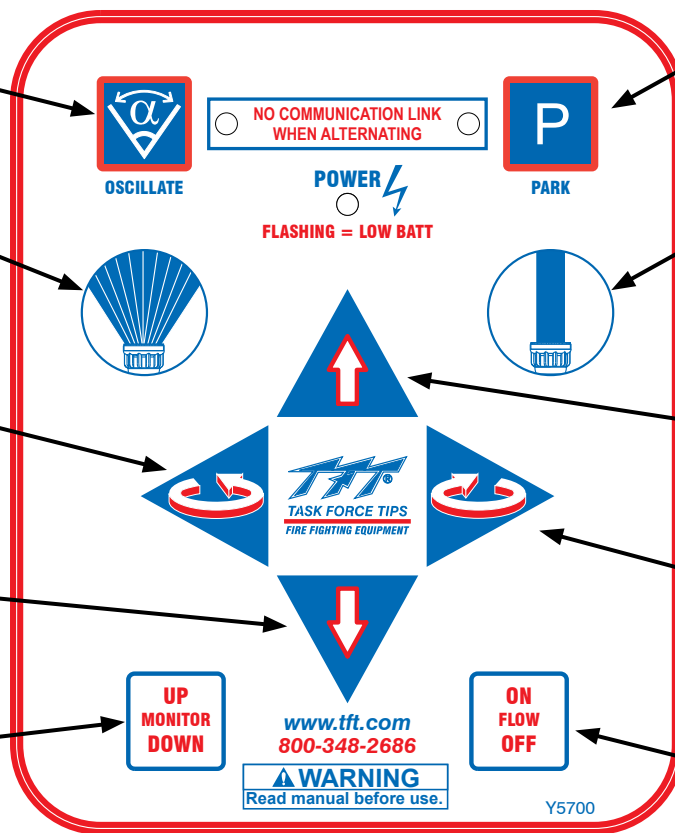

PARK button used to initiate monitor storage sequence or to program storage movements.

STRAIGHT STREAM button used to move nozzle pattern to narrow and long reach.

UP button used to move water stream vertically up from starting point.

RIGHT button used to rotate (sweep) water stream from left to right from starting position.

AUX2 button typically used to control RC Valve Kit. Could also be used with YE-REMAUX relay interface box to control other devices.

Fig. 2.2.5
Operation Label

2.3 TETHERED OPERATOR STATION (Y4E-CT-##)

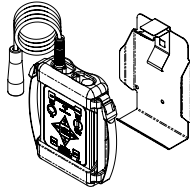

This operator station will have a factory installed 4-conductor cable, which will act as a tether, with a plug on the end. The installer will need to mount the storage bracket and receptacle.

2.3.1 MOUNTING STORAGE BRACKET

The storage bracket is supplied with (3) 1/4-20 stainless steel self-tapping screws. Make sure the material beneath the bracket is substantial and thick enough to hold self-tapping screws. Make sure the area on the backside of the mounting surface is clear of obstructions. We recommend a minimum thickness of 3/32" (.093" - 2.4 mm) in aluminum and 5/64 (.078"-2mm) in steel. See the chart in Figure 2.3.1 to determine the correct pilot hole size.

Select proper location for mounting storage bracket. Panel space required will be 6.0" x 11.2" (152 x 285mm). Refer to Figure 2.3.1 for hole dimensions. Bracket can be used as a template. **Be sure spring is in position.**

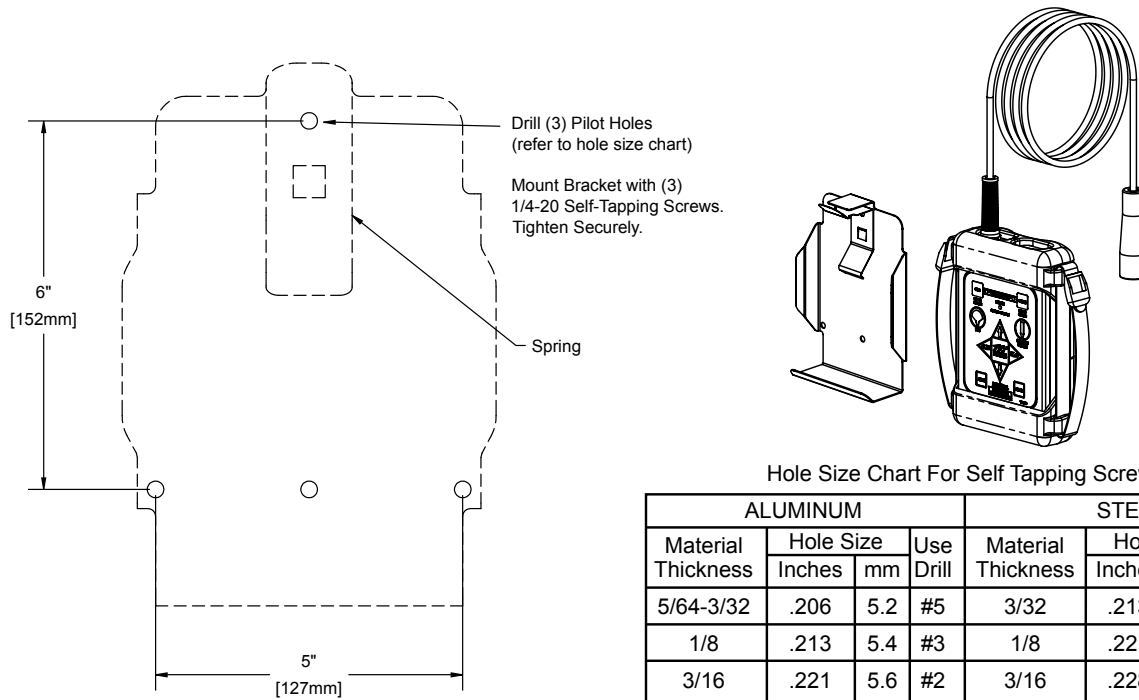

Figure 2.3.1
Tethered Operator Station Storage Bracket Hole Dimensions

2.3.2 RECEPTACLE MOUNTING

Select proper location for mounting receptacle. Receptacle is 1-1/4" x 1-1/4" and 1/2" deep. (32 mm x 32 mm x 13 mm) Allow extra room behind receptacle for wires. Refer to Figure 2.3.2 for hole dimensions.

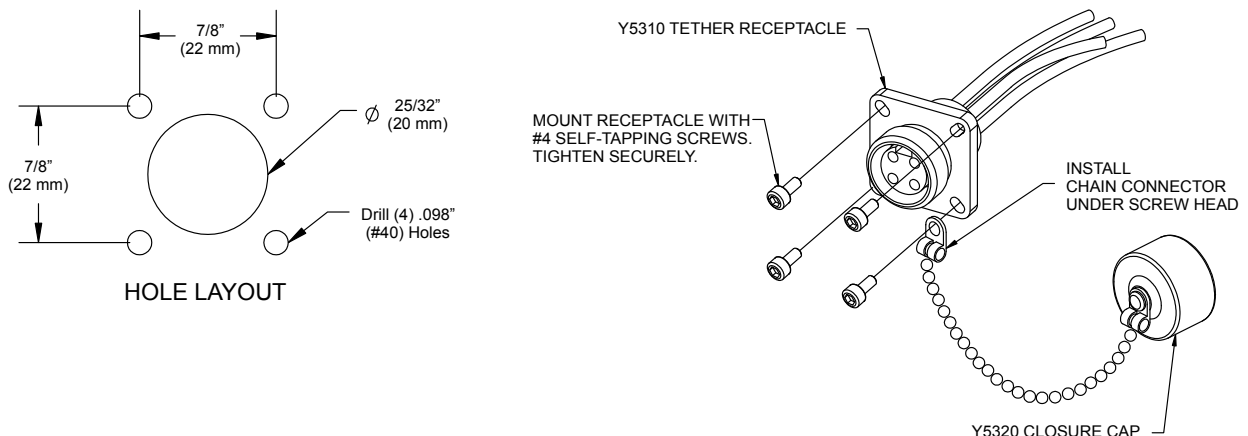

Fig 2.3.2
Tether Operator Station Receptacle Hole Dimensions

2.3.3 ELECTRICAL WIRING

See figure 2.0 for typical connections. The 4-conductor cable from the receptacle needs to be connected to power (red & black) and to the communication link (blue & white) from the monitor. Refer to Figure 2.2.2 for typical cable preparation.

2.3.4 OPERATION

This operator station is tethered to the truck with a 30 foot (9 meter) or 10 foot (3 meter) cable. It is used to move slightly away from the truck to get a better view for redirecting the monitor.

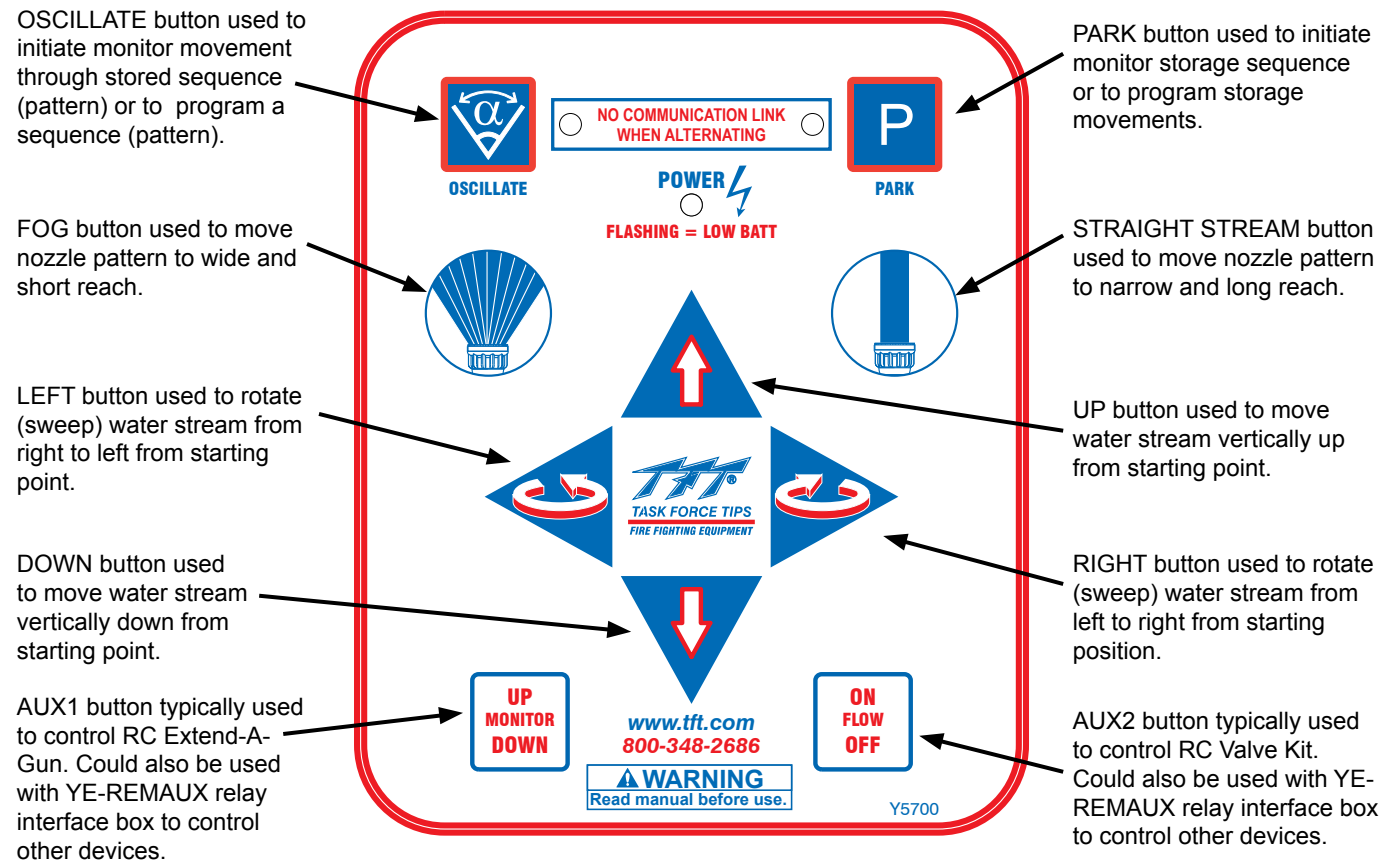
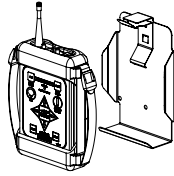

Fig. 2.3.4
Operator Station Label

2.4 WIRELESS OPERATOR STATION



The YE-RF-## Wireless Operator Station is supplied with a radio board that needs to be installed in the monitor control box and a storage bracket.

2.4.1 MOUNTING STORAGE BRACKET

The storage bracket is supplied with (3) 1/4-20 stainless steel self-tapping screws. Make sure the material beneath the bracket is substantial and thick enough to hold self-tapping screws. Make sure the area on the backside of the mounting surface is clear of obstructions. We recommend a minimum thickness of 3/32" (.093" - 2.4 mm) in aluminum and 5/64 (.078"-2mm) in steel. See the chart in Figure 2.4.1 to determine the correct pilot hole size.

Select proper location for mounting storage bracket. Panel space required will be 6.0" x 11.2" (152 x 285mm). Refer to Figure 2.4.1 for hole dimensions. Bracket can be used as a template. Be sure spring is in position.

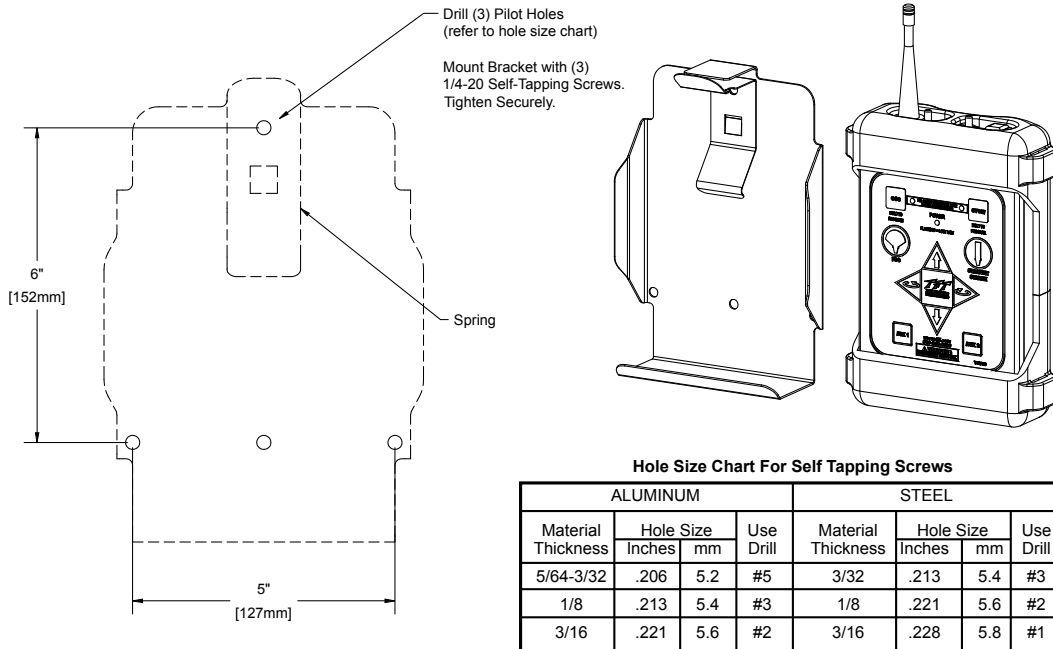

Fig 2.4.1 Wireless Operator Station Storage Bracket Hole Dimensions

2.4.2 INSTALLING RADIO/ANTENNA

Turn off power and remove lid from monitor control box. Be careful to open lid slowly as lid will be connected to communication board by a flat cable.

ANTENNA (for 2.4 GHz)

- 1) Remove hex plug (if installed) from top of control box.
- 2) Install antenna fitting with Loc-tite® into threaded hole.

RADIO

- 1) Unplug connector with blue & white wires and remove the small communication board on the far left.
- 2) Attach antenna connector to radio board with the cable in the orientation shown in Fig 2.4.2a. **Note: In some RC monitors, cable tie may need to be cut to attach antenna.**
- 3) Plug radio board into communication board. (Fig 2.4.2b) Be careful to line up pins.
- 4) Plug communication board/radio board into main board. Press down to seat securely.
- 5) Insert connector with blue & white wires into communication board.

Replace lid onto box. Be sure to guide flat cable down onto motor boards and to not pinch any wires between lid and box.

Tighten lid screws equally in a criss-cross pattern.

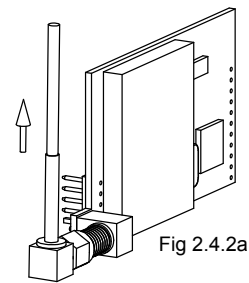

Fig 2.4.2a

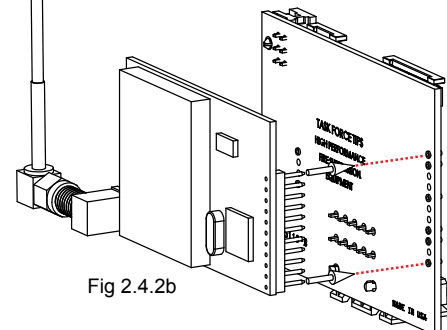

Fig 2.4.2b

2.4.3 TEACHING ID CODE:

NOTE: When the operator station is purchased at the same time as RC monitor, handheld unit will be pre-taught at factory.

NOTE: Before teaching, monitor should be powered down.

NOTE: If multiple monitors are present, apply power only to the monitor being taught, otherwise possible conflicts may occur.

Every monitor has a unique ID code that must be “taught or transferred” to the wireless handheld unit. This unique ID code allows multiple monitors to be used in one location without interference. Perform the following procedure to teach the handheld unit.

On Wireless Handheld Unit:

- Press POWER button to turn on electronics.
- Press and hold both LEFT & RIGHT buttons simultaneously for 5 seconds.
- Continue to press the LEFT & RIGHT buttons and then press UP button for 2 seconds.
- Release buttons. After several seconds the OSC & STOW lights will flash rapidly to indicate that the unit is in teach mode.

On Monitor Control Box:

- Apply power to monitor.
- Press and hold both LEFT & RIGHT buttons simultaneously for 5 seconds.
- Continue to press the LEFT & RIGHT buttons and then press UP button for 2 seconds.
- Release buttons. After several seconds the OSC & STOW lights will flash rapidly to indicate that the unit is in teach mode. ID code is automatically transferred to the wireless handheld unit.
- OSC & STOW lights on handheld unit will stop flashing after ID code is transferred.
- Press DOWN button on monitor control box to exit teach mode.
- Cycle power off and back on to monitor.

In the event the handheld unit does not link up with the monitor, perform the following at the monitor operator station and the handheld unit.

- Turn off power.
- Press and hold DOWN button.
- Apply power to the monitor, continue to hold DOWN button for 3 seconds.
- Release DOWN button.
- After green POWER light stops blinking, test wireless handheld unit.
- Repeat above procedure for “Teaching ID Code”

2.4.4 CHANGING BATTERIES:

Four (AA) Batteries, Lithium Recommended

- Remove two (2) screws on backside of handheld unit and slide bottom half of rubber bumper off enclosure.
- Replace batteries verifying that polarity is correct.
- Replace rubber bumper and retaining screws.



Properly dispose of old batteries. Do not puncture, incinerate, or disassemble batteries. Do not mix battery types.

2.4.5 OPERATION

The Wireless Operator Station allows a user to move away from the truck to get a better view for redirecting the monitor. This operator station gives the user full control of the monitor including the PARK, OSCillate, and any AUXiliary functions. For TFT RC monitors shipped with the antenna pre-mounted in the monitor control box, all the user needs to do is mount the storage bracket and teach the ID code to the handheld unit.

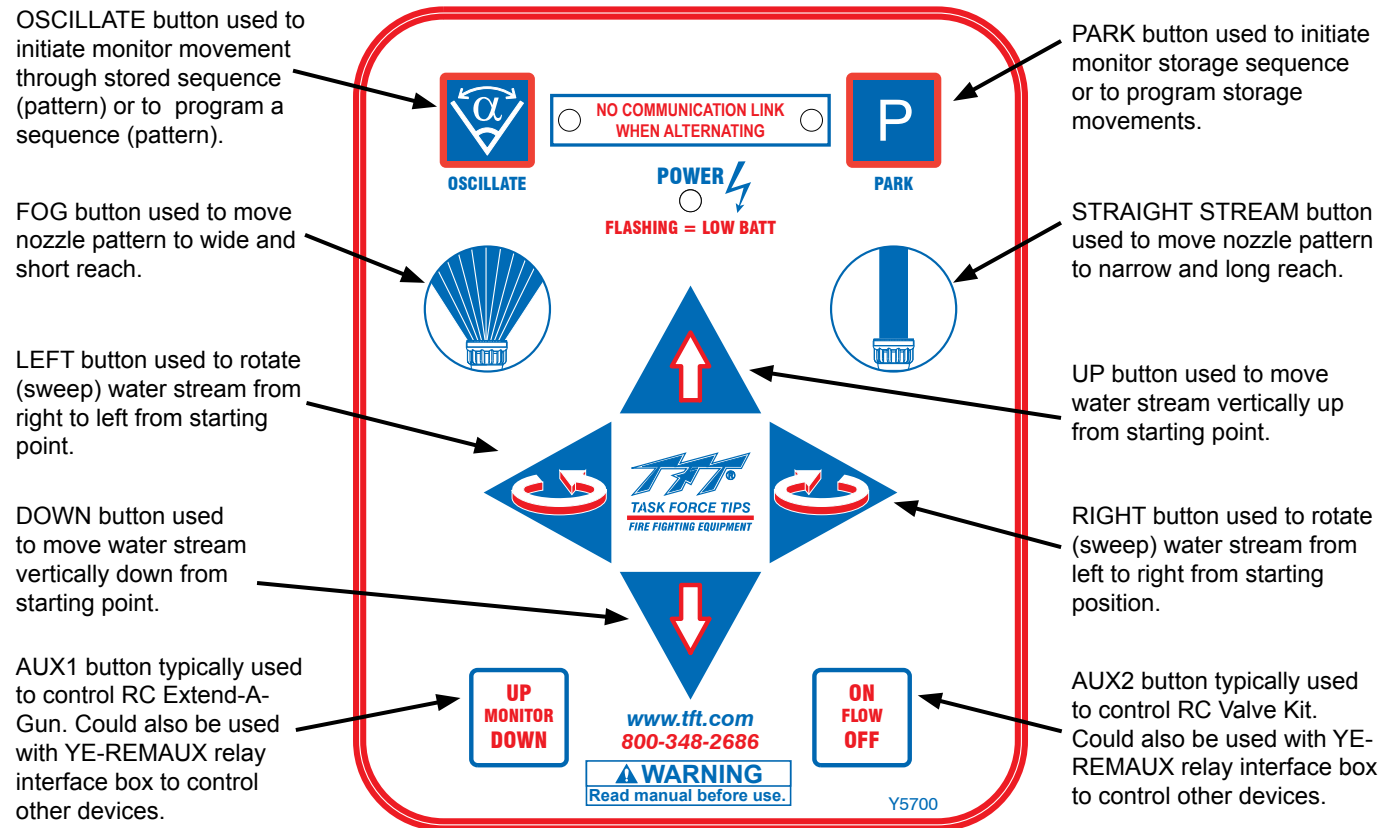

Fig. 2.4.5
Operator Station Label

The range of the wireless operator station is 500 ft (152 m) and the handheld unit is powered by four (4) AA batteries, lithium batteries are recommended. Lithium batteries will provide 33 hours of continuous operation. When the battery voltage is low, the POWER light will begin to flash. At this point there are approximately 3 hours of continuous operation remaining.

The handheld unit will automatically turn off after 5 minutes if no buttons are pressed.

-Press POWER button to turn on electronics.

-Use operator station just like any other wired operator station.

-Press POWER button again to turn off electronics or after 5 minutes of idle operation, handheld unit will automatically turn off.

NOTE!!! If after pressing a button, the OSC & PARK lights alternately flash, this indicates no communication link is present with the monitor. The handheld unit is out of range or cannot establish a link with the monitor. Move to a different location and then retry, also verify monitor has power applied.

2.5 JOYSTICK OPERATOR STATION (Y4E-JS)

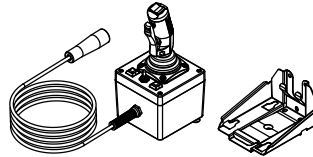

This operator station allows the monitor to be controlled by a joystick. The installer will need to mount the joystick control and connect the cable to a receptacle or terminal box with power and communication connections. The joystick control needs to be mounted in a weatherproof location, for example, inside the cab of the truck.

2.5.1 MOUNTING STORAGE BRACKET

The storage bracket (A) and spring (B) is supplied with (3) 1/4-20 stainless steel self-tapping screws (E). Make sure the material beneath the bracket is substantial and thick enough to hold self-tapping screws. Make sure the area on the backside of the mounting surface is clear of obstructions. A minimum thickness of 3/32" (.093" - 2.4 mm) in aluminum and 5/64" (.078" - 2mm) in steel is recommended. See the chart in Figure 2.5.1.1. The bracket can be mounted from the bottom (See Figure 2.5.1.5) or bottom (See Figure 2.5.1.3). When installed in the side configuration, (2) 1/4-20 button head cap screws (F) and (2) locking nuts (G) should be installed as shown in Figure 2.5.1.3.

Hole Chart For Self Tapping Screws							
ALUMINIUM				STEEL			
Material Thickness	Hole Size		Use Drill	Material Thickness	Hole Size		Use Drill
	Inches	mm			Inches	mm	
5/64-3/32	0.206	5.2	#5	5/64-3/32	0.206	5.2	#5
1/8	0.213	5.4	#3	1/8	0.213	5.4	#3
3/16	0.221	5.6	#2	3/16	0.221	5.6	#2

Fig 2.5.1.1
Joystick Operator Station Hole Dimensions

Install joystick instruction label nearby for quick operation reference.

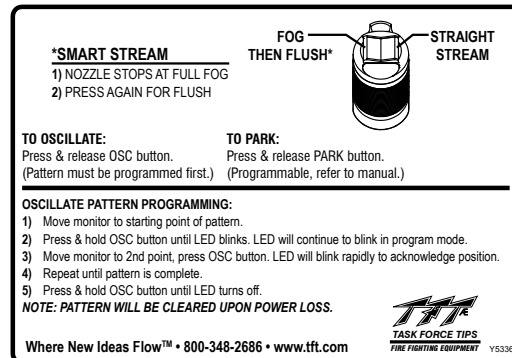

Fig 2.5.1.2
Joystick Instruction Label

KEY INSTALLATION

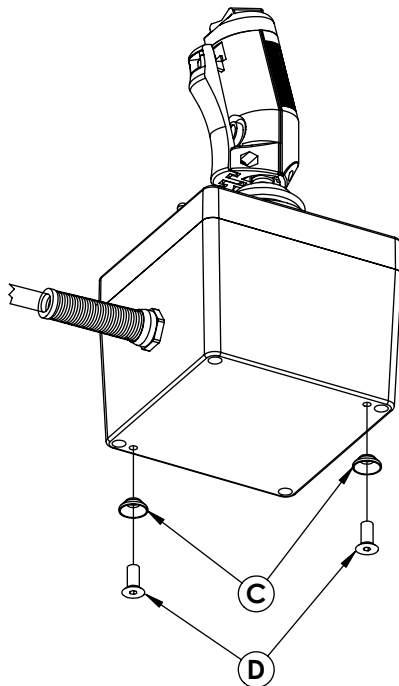

Fig 2.5.1.3

ID	DESCRIPTION	QTY	ORDER #
A	LATCH SPRING	1	Y7032
B	MOUNTING BRACKET	1	Y7031
C	KEY	2	Y7033
D	1/4-20 X 1/2 FLAT HEAD CAP SCREW	2	VT25-20FH500
E	1/4-20 X 3/4 SELF TAPPING HEX SCREW	3	VT25-20HX750
F	1/4-20 X 3/8 BUTTON HEAD CAP SCREW	2	VT25-20BH375
G	1/4-20 LOCKING NUT	2	VT25-20LNT

Fig 2.5.1.4

SIDE MOUNTING OPTION

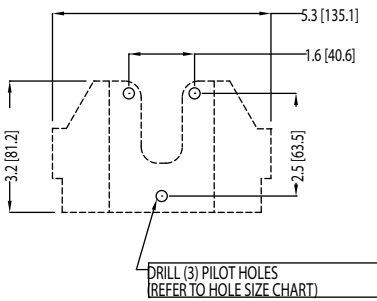
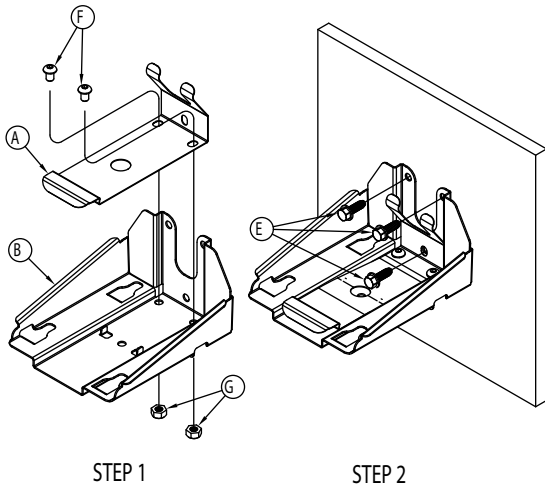

Fig 2.5.1.5
Bracket Side Mounting Option

BOTTOM MOUNTING OPTION

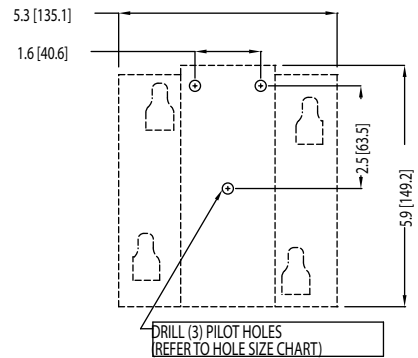
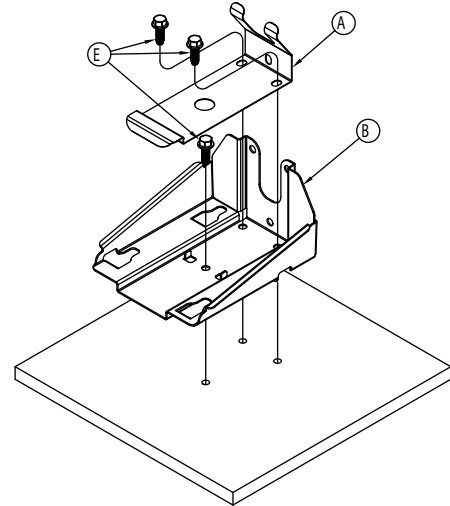

Fig 2.5.1.6
Bracket Bottom Mounting Option

2.5.2 OPERATION

This operator station is installed in a protected location and allows the monitor to be controlled by a joystick.

Push OSC button to initiate pre programmed water stream movements.

Press right side of rocker thumb switch to move nozzle actuator to STRAIGHT STREAM position.

Press left side of rocker thumb switch to move nozzle actuator to FOG position.

Move joystick LEFT to rotate monitor counterclockwise in the horizontal direction.

Squeeze TRIGGER lever to open water valve. Release TRIGGER lever to close water valve. **NOTE: Toggle switch must be in left (Joystick Control) position to activate TRIGGER Control.**

Move TOGGLE SWITCH to right position to open water valve and maintain open, to center position to close water valve and maintain closed, and to left position to activate joystick TRIGGER control of water valve position.

Push PARK button to initiate pre programmed storage movements.

Move joystick FORWARD to move monitor down in the vertical direction.

Move joystick RIGHT to rotate monitor clockwise in the horizontal direction.

Move joystick BACK to move monitor up in the vertical direction.

Fig. 2.5.2
Joystick Label

2.6 TOGGLE SWITCH OPERATOR STATION (Y4E-TS)

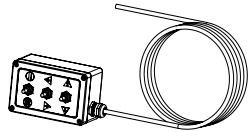

This operator station allows the monitor to be controlled by three toggle switches. The installer will need to mount the operator station and connect the cable to the monitor and power.

2.6.1 ENCLOSURE MOUNTING

Select proper operator location. Enclosure is designed to be surface mounted and the size is 5" x 3 1/8" (127 x 80mm). Height to top of switches is 3 1/8" (80mm). Refer to Figure 2.6.1 for mounting hole dimensions.

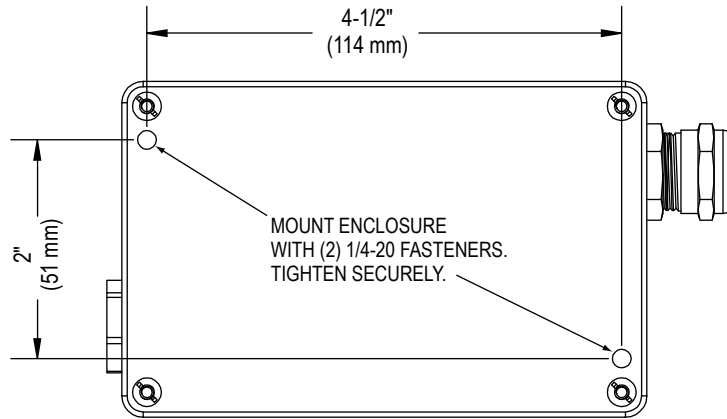

Figure 2.6.1
Toggle Switch Operator Station Hole Dimensions

2.6.2 ELECTRICAL WIRING

See figure 2.0 for typical connections. The 4-conductor cable from the operator station needs to be connected to power (red & black) and to the communication link (blue & white) from the monitor. Refer to Figure 2.2.2 for typical cable preparation.

2.6.3 OPERATION

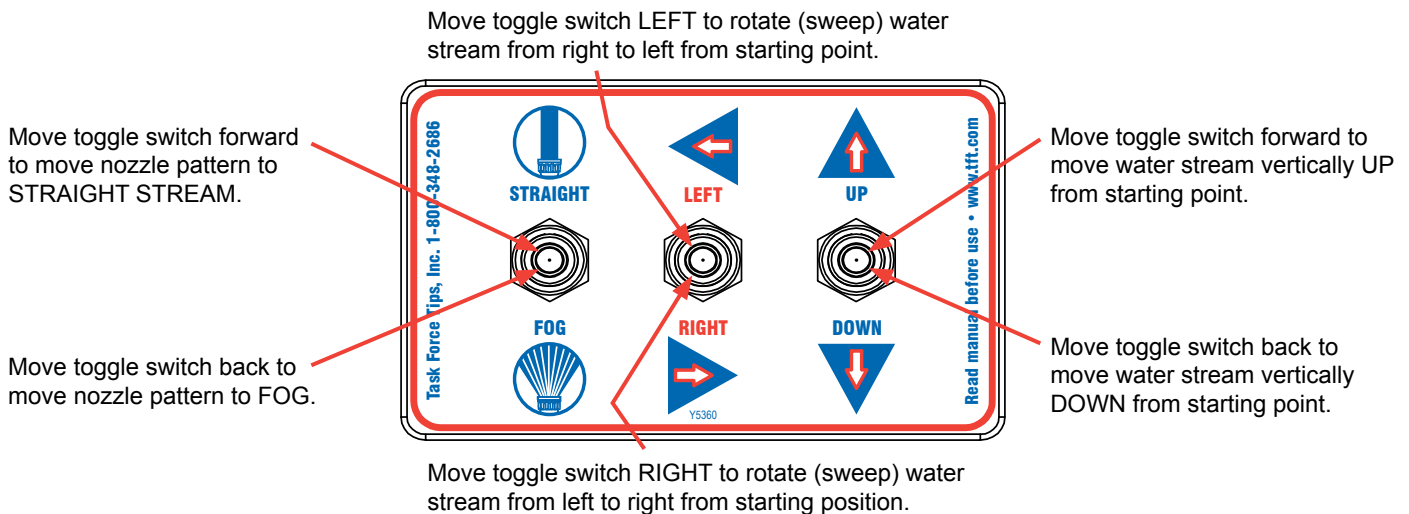
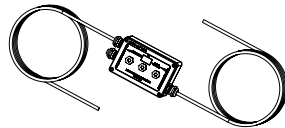

Fig. 2.6.3
Operator Station Label

2.7 COMMUNICATION INTERFACE CONTROL (Y4E-COMM)



This Communication Interface Control converts discrete input signals into serial communications for controlling the monitor. The discrete input signals can be from a joystick, toggle switches, relay contacts or Canbus output module. The interface box accepts +12/24 VDC signals, but can be field changed to accept ground signals. The installer will need to mount the interface box and connect the cable to the monitor and power.

2.7.1 ENCLOSURE MOUNTING

Select proper enclosure location. Enclosure is designed to be surface mounted and the size is 5" x 3 1/8" (127 x 80mm). Height of enclosure is 2 3/8" (60mm). Refer to Figure 2.6.1 for mounting hole dimensions.

2.7.2 ELECTRICAL WIRING

See figure 2.0 for typical connections. The 4-conductor cable from the communication interface box needs to be connected to power (red & black) and to the communication link (blue & white) from the monitor. Refer to Figure 2.2.2 for typical cable preparation.

See figure 2.7.2 for connecting INPUTS cable.

Function	Interface Box Cable Color
UP	WHITE
DOWN	BLUE
LEFT	YELLOW
RIGHT	BROWN
FOG	GREEN
STREAM	ORANGE
(-) BLACK	BLACK
(+) RED	RED

Figure 2.7.2
Communication Interface Wire Color/Function

2.7.3 INPUTS SIGNAL CONFIGURATION

The Communication Interface Control is shipped from the factory configured to accept +12/24 volt DC input signals, but can be field changed to accept ground input signals. To change the configuration:

1. Remove lid from enclosure.
2. Locate DIP switches on communication board.
3. Slide DIP switch #4 to the OFF position to select GROUND inputs or slide to the ON position to select VOLTAGE inputs.
4. Replace lid. Verify rubber seal is clean and undamaged. Verify that no wires are caught between lid and box.

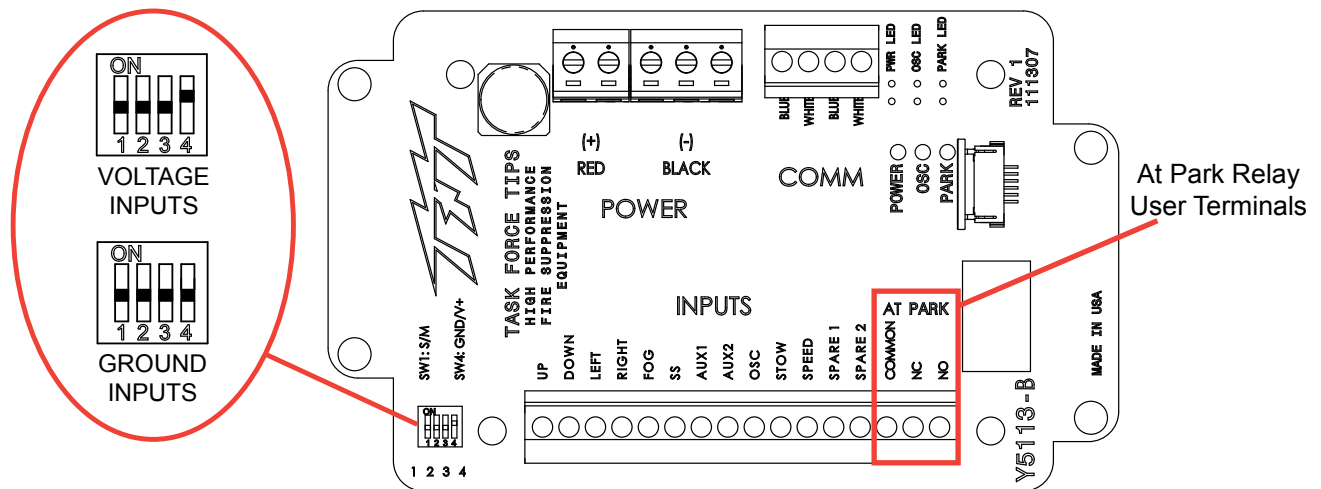

Fig 2.7.3
Relay/Terminal Location

2.7.4 COMMUNICATION INTERFACE CONTROL WITH AT PARK RELAY (Y4E-COMM)

The Communication Interface Box provides feedback for the user that the monitor is in the AT PARK position. The Interface Box contains a circuit board that is equipped with a relay that is energized when the monitor is in use and de-energized when the monitor reaches its final PARK location. The contact rating of the relay is 1 amp @ 30VDC for resistive loads and 0.2 amps @ 30VDC for inductive loads.

The AT PARK relay has one Form-C contact (common, normally open, normally closed) that can be used. Figure 2.7.3 shows the terminal blocks available for user wiring.

2.8 MONITOR POSITION DISPLAY (Y4E-DISP)

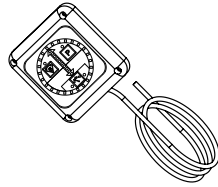

The monitor position display is supplied with a 10' (3 m) long 4-conductor cable. The installer will need to surface mount the enclosure in a dry area and connect the cable to power and the communication link of the monitor. Once the RC monitor and position display are installed and operational, the installer will need to program or teach the position display the full travel of the RC monitor.

2.8.1 ENCLOSURE MOUNTING

Select proper location for display.

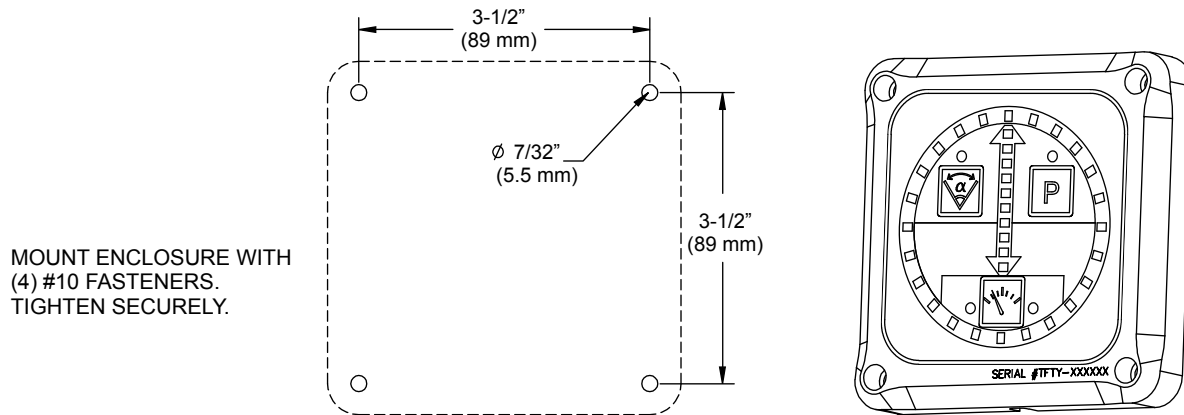

Fig 2.8.1
Monitor Position Display Hole Dimensions

2.8.2 ELECTRICAL WIRING

See figure 2.0 for typical connections. The 4-conductor cable from the monitor position display needs to be connected to power (red & black) and to the communication link (blue & white) from the monitor. The cable exits the back side of the enclosure and can be installed straight back thru an opening in a panel or laid into groove in enclosure for flush mounting. Refer to Figure 2.2.2 for typical cable preparation.

2.8.3 PROGRAMMING DISPLAY

In order to correctly display the RC monitor position, **THE POSITION DISPLAY NEEDS TO BE TAUGHT THE FULL TRAVEL OF EACH AXIS**. The sequence is to program the “LEFT” stop, then “RIGHT” stop of the horizontal axis and next the “UP” stop and then “DOWN” stop for the vertical axis. Perform the following procedure to setup the position display.

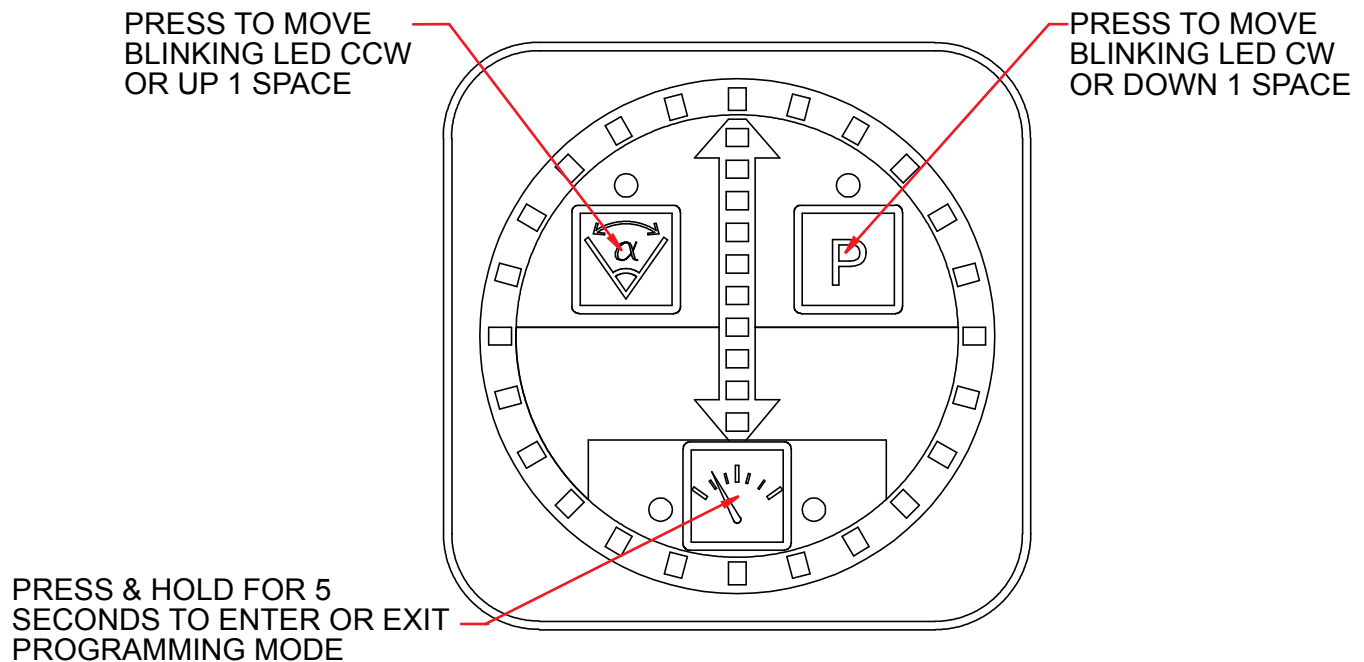

Fig 2.8.3

Enter Programming Mode

- With power off, press and hold SPEED button on position display
- Apply power and continue to hold SPEED button until speed lights start to blink. One horizontal axis light will also be blinking.

Teach Left Stop

- Operate RC monitor to the full left travel stop.
- Using OSC button move blinking light (counter clockwise) to appropriate location of horizontal travel.
- Press & hold OSC button for 5 seconds to store location. Horizontal axis light will change positions once location is stored.

Teach Right Stop

- Operate RC monitor to the full right travel stop.
- Using PARK button move blinking light (clockwise) to appropriate location of horizontal travel.
- Press & hold PARK button for 5 seconds to store location. Vertical axis light will start to blink once location is stored.

Teach Up Stop

- Operate RC monitor to the full up travel stop.
- Using OSC & PARK buttons move blinking light to appropriate location of vertical travel.
- Press & hold OSC button for 5 seconds to store location. Vertical axis light will change positions once location is stored.

Teach Down Stop

- Operate RC monitor to the full down travel stop.
- Using OSC & PARK buttons move blinking light to appropriate location of vertical travel.
- Press & hold PARK button for 5 seconds to store location. Display will start to blink all 4 stop locations once location is stored

Exit Programming Mode

- Press & hold SPEED button for 5 seconds to exit programming mode. Speed lights will stop blinking.

2.9 REMOTE AUXILIARY INTERFACE CONTROL (YE-REMAUX)

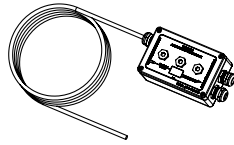

The Remote Auxiliary Interface Control allows a user to utilize the AUX1 and AUX2 buttons located on the monitor operator station or any remote operator station. The Interface Control is equipped with two relays that can operate lights, interface to a valve controller or in some cases operate a valve directly, etc. The contact rating of the relay is 16 amps @ 30VDC for resistive loads and 8 amps @ 30VDC for inductive loads.

The installer will need to mount the interface control and connect the cable to power and the communication link of the monitor.

NOTICE The Interface Control provides no overload protection for the device it is controlling. Failure to provide overload protection will damage relay contacts, which will disable device being controlled. Provide manual device operation, where necessary, in addition to remote control.

2.9.1 ENCLOSURE MOUNTING

Select proper enclosure location. Enclosure is designed to be surface mounted and the size is 5" x 3 1/8" (127 x 80mm). Height of enclosure is 2 3/8" (60mm). Refer to Figure 2.9.1 for mounting hole dimensions.

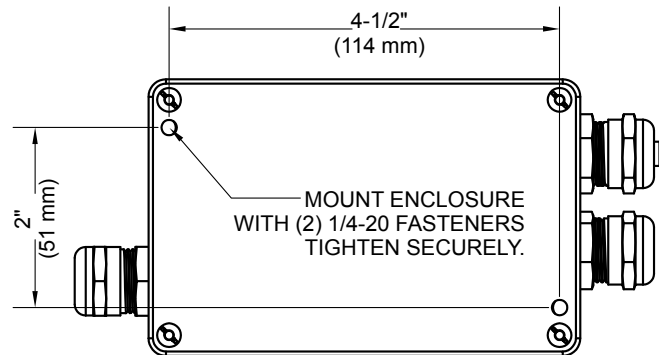

Figure 2.9.1
Remote Aux. Interface Box Hole Dimensions

2.9.2 ELECTRICAL WIRING

See figure 2.0 for typical connections. The 4-conductor cable from the communication interface box needs to be connected to power (red & black) and to the communication link (blue & white) from the monitor. Refer to Figure 2.2.2 for typical cable preparation.

Each relay has one Form-C contact (common, normally open, normally closed) that can be used.

2.9.3 CONFIGURATION

The two relays on the circuit board can be individually configured as AUX1 or AUX2. Also the actuation of each relay can be configured to be momentary or latching. See Figure 2.9.3 for relay configuration DIP switch settings.

1. Remove lid from interface box.
2. Locate DIP switches on board and select configuration.
3. Replace lid. Verify rubber seal is clean and undamaged. Verify that no wires are caught between lid and box.

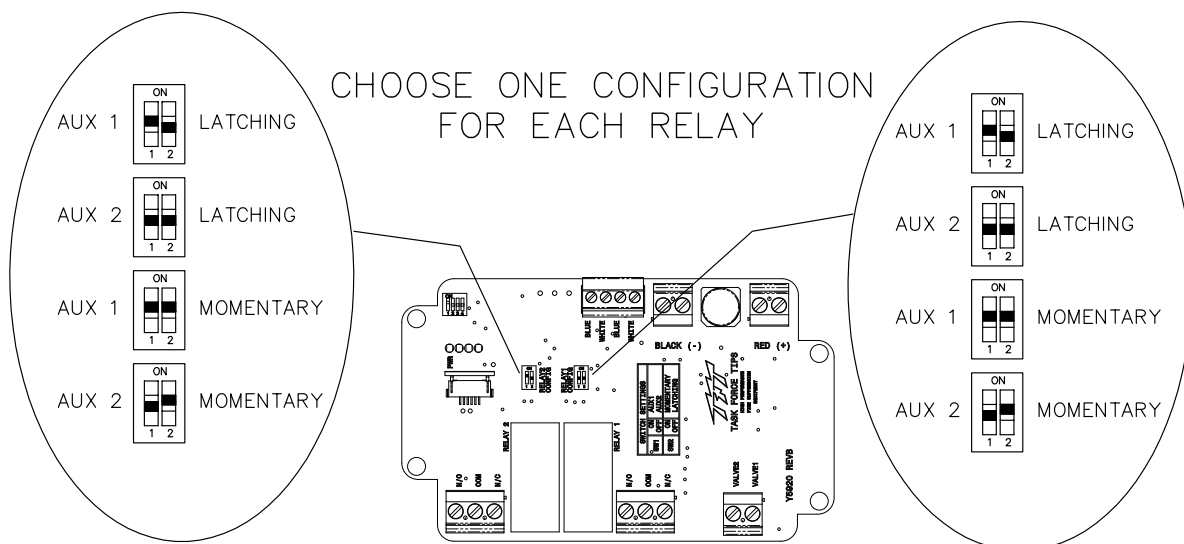
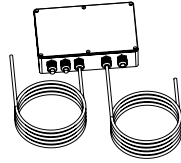

Figure 2.9.3
Relay Configuration

2.10 ELECTRICAL RC MONITOR AERIAL TRUCK INSTALLATION



Two versions of the RC monitor have been designed for installation on aerial device trucks, the “-L” and “-P” versions. The “-L” version is supplied with one cable for connecting discrete inputs into the electronics enclosure, typically connections to a Canbus output module or toggle switches located at the turntable. The “-P” version is supplied with two cables for connecting discrete inputs, one cable typically for controls located in the basket and one cable for controls located at the turntable.

2.10.1 ELECTRONICS ENCLOSURE MOUNTING

Select proper enclosure location. Enclosure is designed to be surface mounted and the size is 5 3/4" x 8 3/4" (146 x 222mm). Height of enclosure is 2 1/4" (57mm). Refer to Figure 2.10.1 for mounting hole dimensions.

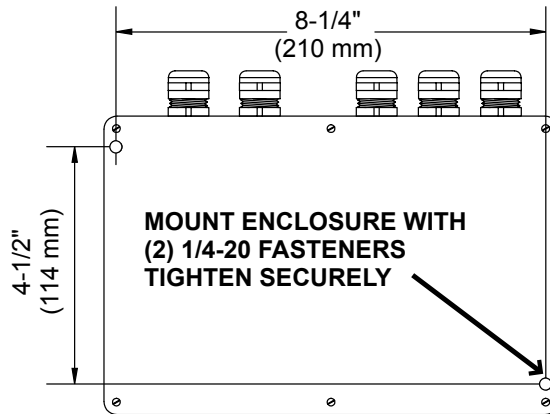

Fig 2.10.1
Electrical Enclosure Mounting Hole Dimensions

2.10.2 ELECTRICAL WIRING

On aerial devices, the installer will supply the required cables that run up the ladder or boom. Be sure to perform voltage drop calculations to verify that the supply voltage will remain at an acceptable level during monitor operation.

2.10.2.1 LADDER INSTALLATION ELECTRICAL WIRING (-L MODELS)

The electronics enclosure converts discrete input signals into serial communications for controlling the monitor. The discrete input signals can be from a joystick, toggle switches, relay contacts or Canbus output module. The electronic interface accepts +12/24 VDC signals, but can be field changed to accept ground signals.

The electronics enclosure is configured so that signals connected to the PRIMARY CONTROL cable will override any other operator stations (see section 2.0.1 and 2.0.2).

See Figure 2.10.2.1 for wiring connections.

NOTE: To avoid excessive voltage drop at monitor operator station, cable selection is critical. Voltage supplied to ELECTRONICS ENCLOSURE should not fall below 11 volts when monitor is in operation.

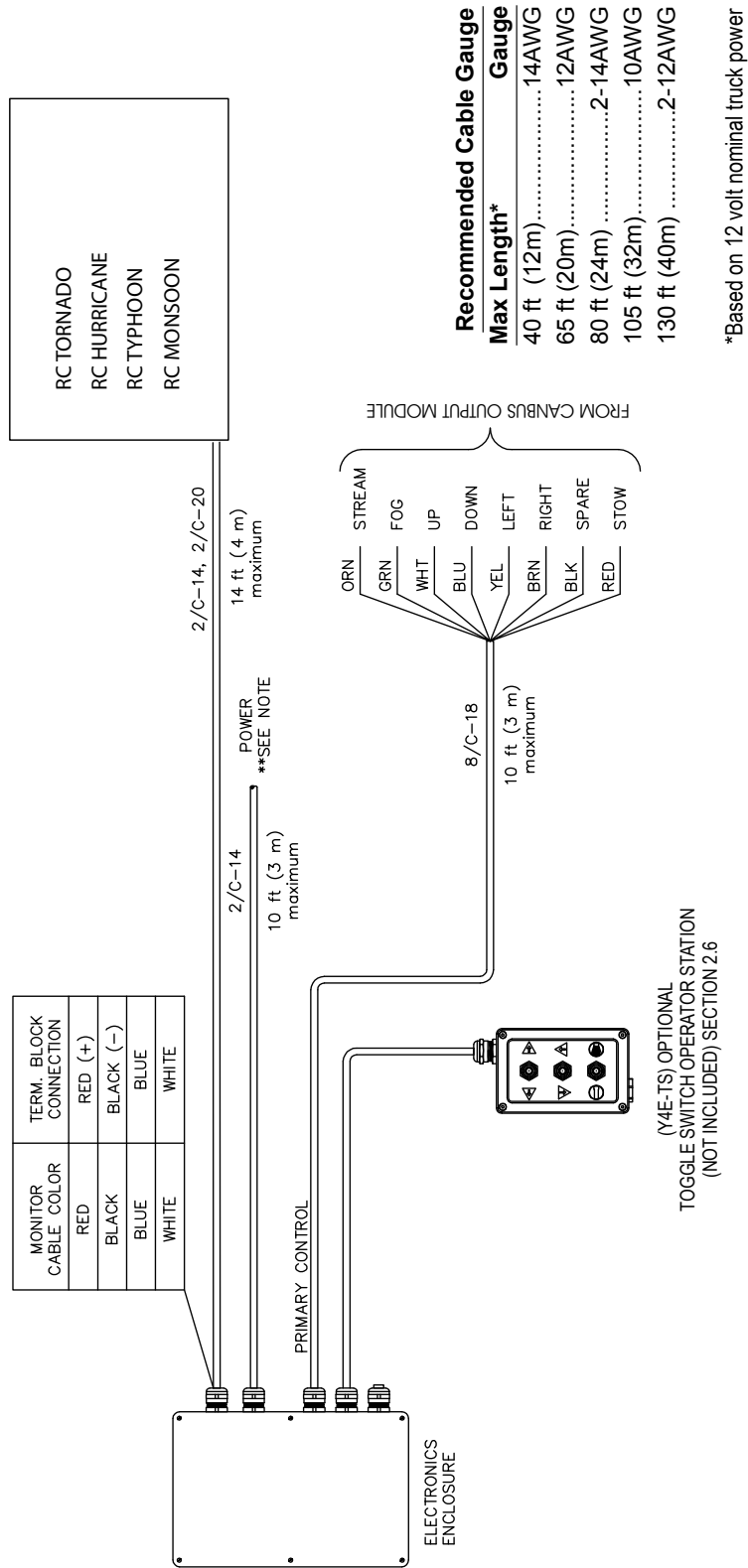

Figure 2.10.2.1
Electrical Components (ladder installations)

2.10.2.2 PLATFORM INSTALLATION ELECTRICAL WIRING (-P MODELS)

The electronics enclosure converts discrete input signals into serial communications for controlling the monitor. The discrete input signals can be from a joystick, toggle switches, relay contacts or Canbus output module. The electronic interface accepts +12/24 VDC signals, but can be field changed to accept ground signals.

The electronics enclosure is configured so that signals connected to the PRIMARY CONTROL cable will override any other operator stations (see section 2.0.1 and 2.0.2).

See Figure 2.10.2.2 for wiring connections.

NOTE: To avoid excessive voltage drop at monitor operator station, cable selection is critical. Voltage supplied to ELECTRONICS ENCLOSURE should not fall below 11 volts when monitor is in operation.

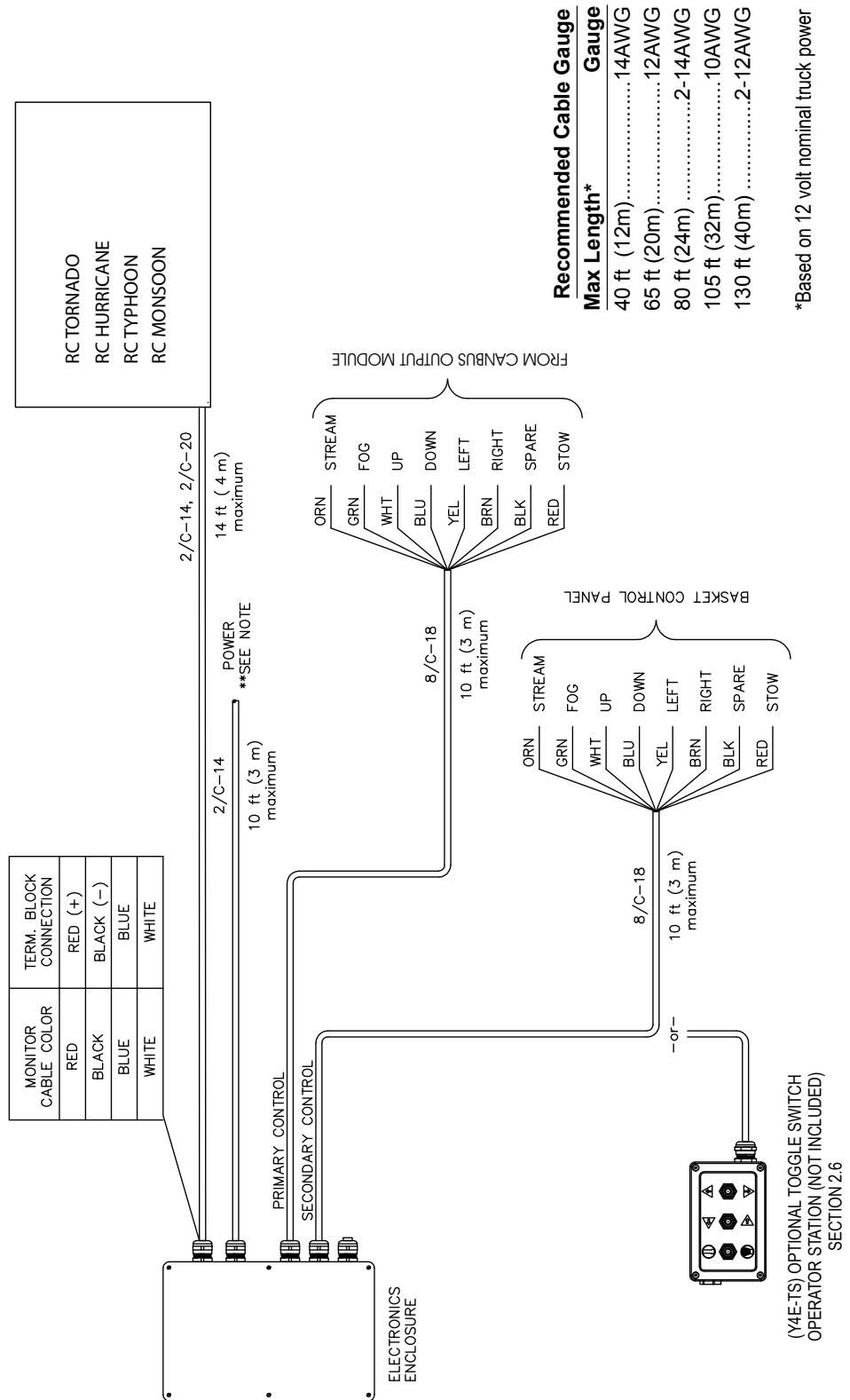

Figure 2.10.2.2
Electrical Components (platform installations)

2.10.3 ELECTRICAL ENCLOSURE WITH AT PARK RELAY

The electronics enclosure provides feedback for the user that the monitor is in the AT PARK position. This electronics enclosure contains a circuit board that is equipped with a relay that is energized when the monitor is in use and de-energized when the monitor reaches its final PARK location. The contact rating of the relay is 1 amp @ 30VDC for resistive loads and 0.2 amps @ 30VDC for inductive loads.

2.10.3.1 ELECTRIC CONNECTIONS

The AT PARK relay has one Form-C contact (common, normally open, normally closed) that can be used. The figure below shows the terminal blocks available for user wiring.

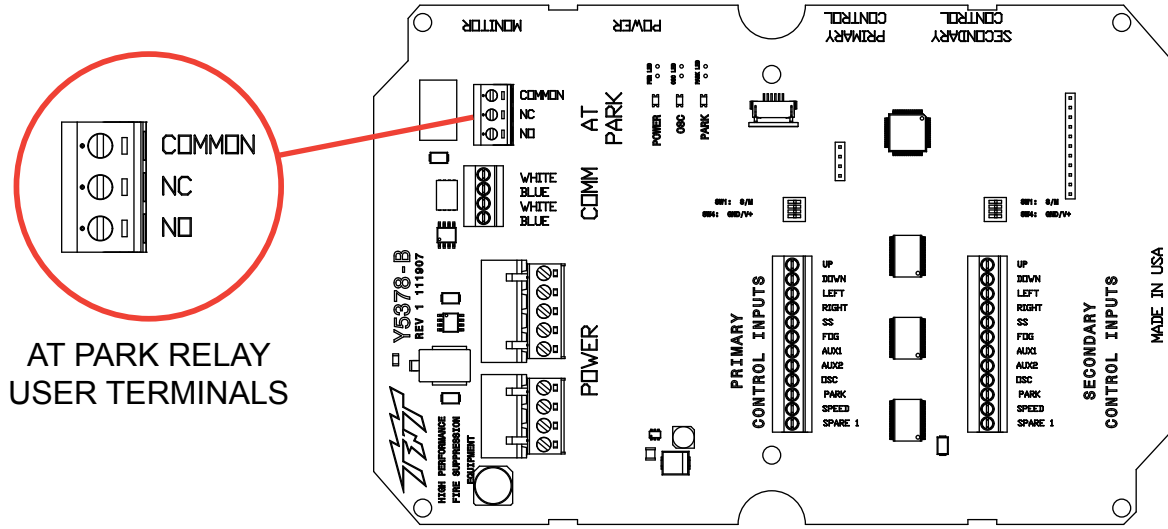

Figure 2.10.3.1
Relay / Terminal Location

2.11 MULTIPLEX INTERFACE CONTROL (YE-CAN#)

This Multiplex Interface Control converts CANbus or multiplex communications into serial communications for controlling a TFT RC monitor or valve. This module is designed to work on a J1939 CANbus system and allows control of all TFT RC Monitors and RC Valve Under Monitor.

Module Installation and Wiring

YE-CAN# module needs to be mounted onto circuit board located in electronics interface box.

- 1) Turn off power and remove lid from electronics interface box.
- 2) Position module and carefully plug into circuit board. Be careful to line up pins.
- 3) Connect CANbus wiring to module based on figure 2.11.
- 4) Replace lid onto box. Be sure to verify gasket is in place and that no wires are pinched between lid and box.
- 5) Tighten lid screws equally in a criss-cross pattern.

Module Configuration

The YE-CAN# module can be configured based on the users requirements. Default configuration will have DIP switch #1 in the ON position with all others off (see CANbus structure document).

Up to four (4) YE-CAN# modules can be installed on the same CANbus communication system. If installing multiple YE-CAN# modules, DIP switches #5 & #6 need to be set accordingly (see CANbus structure document).

Contact TFT for the most up-to-date
CANbus Structure document.

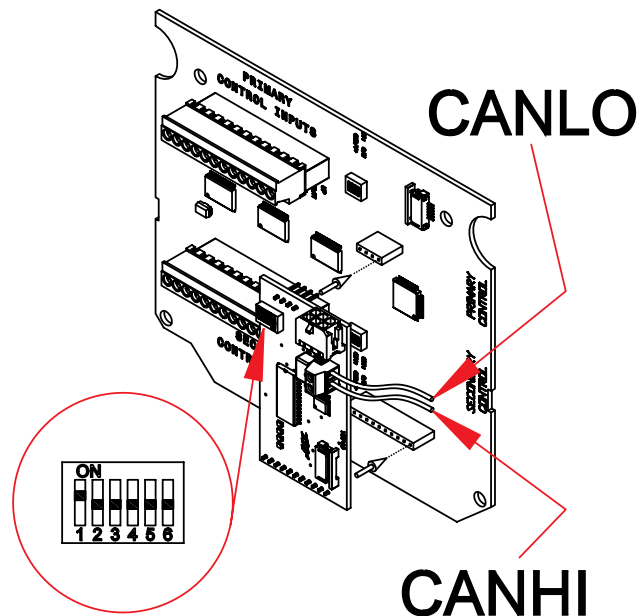
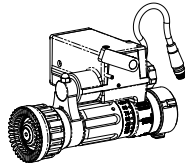

Figure 2.11

2.12 ELECTRIC NOZZLE ACTUATOR



The electrical nozzle actuator is factory installed on the nozzle and requires only to be plugged into the mating monitor connector.

For nozzles with electric pattern control, a cable with a female, waterproof connector is provided at the outlet of the TFT RC Monitor which attaches directly to several of TFT's electric nozzles. The cable used is a dual-key, micro type plug assembly. Any other nozzle should have the corresponding male electrical connector installed. The waterproof cap should be installed when using stacked tips. Do not cut off the female connector on the monitor. This connector is molded onto the cable and must remain in place to maintain the water tightness of the electrical system.

2.12.1 WIRING

The electric RC monitor is designed to control and is factory wired for a TFT electric actuated nozzle. Task Force Tips nozzles are available with a male cord plug. After mounting the appropriate nozzle onto the monitor, plug the male cord from the nozzle into the female cord located on the outlet of the monitor. Make sure the two coupling nuts are tightened securely to ensure a proper watertight seal.

If retrofitting an existing TFT nozzle, a male cord plug (TFT #Y5480) can be purchased and installed in place of the existing actuator cord. Please consult factory for installation.

2.12.2 OPERATION OF FLUSH, FOG, STREAM

Nozzles without flush (All nozzles over 500 GPM)

TFT Remote Controlled (RC) nozzles are equipped with a capability exclusive to TFT called "Smart Stream". Small movements of the outer stream shaper are needed to adjust fine fog while large movements are needed to see any change in straight stream. TFT accomplishes this by using a variable speed motor and sensors to tell the controls when the nozzle is in fog and when it is in straight stream. This capability is especially important on aerial devices where a rapid change between fog and straight stream causes a corresponding large increase in nozzle reaction. This change in nozzle reaction causes the ladder or platform to whip which can be dangerous if not extremely uncomfortable for the occupants. On the back of every nozzle pattern actuator is a small knob that rotates when the nozzle is changing pattern. This knob not only serves the purpose of indicating motor rotation it also is used for manual override in the event of power failure to the monitor. This small knob will change speed as the nozzle moves thru its various patterns. This is NORMAL! Observing this speed change is NOT an indication that the nozzle is binding or malfunctioning. If the end user desires to have this function disabled please call the factory and the correct procedure for accomplishing this change will be sent.

Nozzles with flush (Some nozzles below 500 GPM and all nozzles below 250 GPM)

TFT Remote Controlled (RC) nozzles are equipped with a capability exclusive to TFT called "Smart Stream". Small movements of the outer stream shaper are needed to adjust fine fog while large movements are needed to see any change in straight stream. TFT accomplishes this by using a variable speed motor and sensors to tell the controls when the nozzle is in fog and when it is in straight stream. This capability is especially important on aerial devices where a rapid change between fog and straight stream causes a corresponding large increase in nozzle reaction. This change in nozzle reaction causes the ladder or platform to whip which can be dangerous if not extremely uncomfortable for the occupants. On the back of every nozzle pattern actuator is a small knob that rotates when the nozzle is changing pattern. This knob not only serves the purpose of indicating motor rotation it also is used for manual override in the event of power failure to the monitor. This small knob will change speed as the nozzle moves thru its various patterns. This is NORMAL! Observing this speed change is NOT an indication that the nozzle is binding or malfunctioning. Smart stream serves an additional function when used with nozzles that have flush capability built into the movement of the stream shaper. When nozzles of this type are used on bumper turrets in pump and roll operations it is very important that the operator of the unit not put the nozzle in flush accidentally. A slight over travel past full fog on competitive monitor nozzles will cause the nozzle to enter a partial or complete flush setting. When this occurs the flow of the nozzle can double or triple causing rapid exhaustion of the water supply carried on board the vehicle. With "Smart Stream" technology the nozzle will automatically stop when it achieves the wide fog setting and the motor will cease turning. If the operator desires to flush the nozzle he must release the button and then press it again and the unit will travel into the flush position. Once understood this capability is extremely valuable for conserving tank water. If this feature is not desired by the end user please contact TFT service for instructions on how to disable this feature.

2.13 VALVE KITS

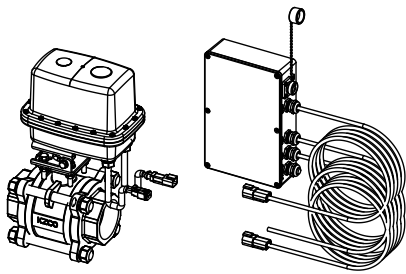

12VDC KITS / 24VDC KITS

YE-VK-PF
 YE-VK-PH
 YE-VK-PJ
 YE-VK-PL

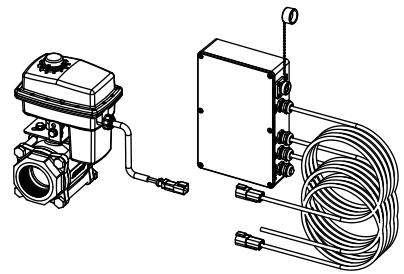

Each kit includes a water valve with plug-in electrical connection(s) and an interface control for “plug and play” wiring for power, water valve, monitor, joystick control and an extra operator station. The installer will need to mount the water valve and the interface box. The interface box is weatherproof and may be installed at any convenient location to route and connect all control system cables.

2.13.1 VALVE MOUNTING

The water valve may be mounted at any location within the plumbing and at any orientation. The wiring and connector from the valve actuator should be protected from pulling and abrasion. The valve inlet and outlet connections and the valve/actuator dimensions are shown in the table below.

TFT Valve Kit #	TFT Valve #	"Inlet and Outlet Thread Connections"	Overall Dimensions inches (mm)		
			Face-to Face	Width	Height
YE-VK-PF	Y7003	1 1/2" NPT	4.8 (122)	7.1 (180)	9.4 (239)
YE-VK-PH	Y7000	2" NPT	5.4 (137)	7.1 (180)	10.0 (254)
YE-VK-PJ	Y7001	2 1/2" NPT	6.7 (170)	8.6 (218)	13.7 (348)
YE-VK-PL	Y7002	3" NPT	7.4 (188)	8.9 (226)	14.3 (363)

2.13.2 INTERFACE ENCLOSURE MOUNTING

The interface box should be mounted at a location to allow all factory-supplied cables to reach and connect. The enclosure is designed to be surface mounted and the size is 5 3/4" x 8 3/4" (146 x 222mm). Height of enclosure is 2 1/4" (57mm). Clearance is needed for the cables that extend from one side. Threaded mounting holes are located on the bottom of the interface box. Refer to Figure 2.10.1 for hole layout.

2.13.3 ELECTRICAL WIRING

Each valve interface box is equipped with several connection points. A receptacle is built-in for connection to a joystick operator station. Two 4-pin plugs are available for connection to a TFT RC monitor, typically a RC Tornado, and for control of a valve. These two cables should be routed to the appropriate device and plugged into the mating receptacle. The power cable should be routed to the truck's power distribution center and connected to a protected circuit. Refer to Figure 2.12.3 for typical connections.

The 2 1/2" and 3" valve actuators also require a separate connection to a protected circuit. These valves are shipped with an additional cable that includes a receptacle for connection to the valve actuator for power.

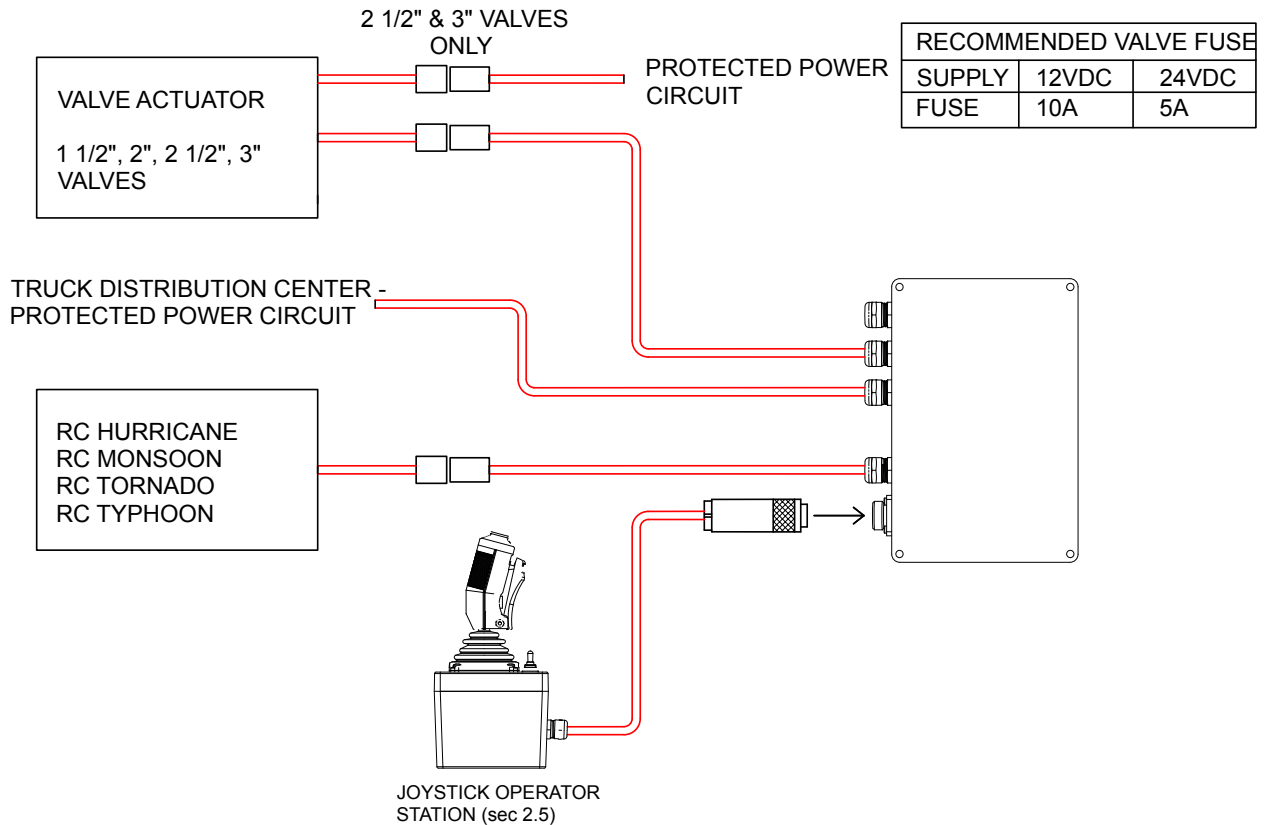

Figure 2.12.3
VALVE ELECTRICAL COMPONENTS

2.13.4 CONFIGURATION

The valve interface control is factory set for AUX2 and Momentary operation. This configuration is most suitable for joystick control of monitor and valve functions. If another operator station with keypad is used, it may be desired to change from momentary to latching operation so that the AUX2 key may be pressed and released once to open the water valve, then pressed and released again to close the valve.

CONSULT FACTORY FOR INSTRUCTIONS TO CHANGE FROM MOMENTARY TO LATCHING OPERATION.

3.0 TROUBLESHOOTING

For online service informatin updates, go to:

<http://www.tft.com/newsite/customerservice/FAQ.asp> Click on Remote Control Monitors.

SYMPTOM	POSSIBLE CAUSE	REMEDY
No Power LED	Polarity reversed	Check wiring and reverse polarity
Power LED On But No Operation	Low voltage due to: - wire gauge too small - wire length too long - poor connection - inadequate apparatus electrical system	Check connections and wiring per Remote Control (RC) Monitor Electrical Controls Supplemental Instructions. Verify voltage is above 9 volts.
	Monitor Disable Interlock turned on	Raise TFT RC Extend-A-Gun
Operation only from monitor operator station. PARK, & OSC LED's on remote station blink slowly when button pressed	Incorrect wiring	Check blue/white communication wiring
	Bad communication board	Replace communication board in monitor. If problem persists, replace communication board in remote operator station.
Monitor will not operate from any station and PARK & OSC LED's on monitor are on solid.	Bad communication board	Replace communication board in monitor.

3.0 TROUBLESHOOTING (continued)

For online service information updates, go to:

<http://www.tft.com/newsite/customerservice/FAQ.asp> Click on Remote Control Monitors.

SYMPTOM	POSSIBLE CAUSE	REMEDY
Operation only from monitor control station	Communication board code version incompatible	Verify code versions on monitor and all operator stations
One Axis Fails To Operate From Any Control Station	Loose motor wiring connection	Check axis motor connection
	Bad motor control board	Interchange motor control boards and check if problem persists with same axis, If not, replace motor control board.
	Bad motor	Interchange motor control boards. Check if problem persists with same axis, If yes, replace motor.
	Bad membrane switch	Replace membrane switch / operator station
Vertical/Horizontal axis will not speed up	Loose encoder wiring connection	Check axis encoder connection
	Bad motor encoder	Interchange motor control boards. Check if problem persists with same axis. If yes, replace motor. Remove encoder cover and check for RED light just below disk. If no light, encoder is bad. Replace motor.
Vertical/Horizontal axis runs only in fast speed	Loose encoder wiring connection	Check axis encoder connection
	Bad motor encoder	Interchange motor control boards. Check if problem persists with same axis. If yes, replace motor. Remove encoder cover and check for RED light just below disk. If no light, encoder is bad. Replace motor.
Vertical/Horizontal axis only runs ~5 seconds and then stops.	Loose encoder wiring connection	Check axis encoder connection
	Bad motor encoder	Interchange motor control boards. Check if problem persists with same axis. If yes, replace motor. Remove encoder cover and check for RED light just below disk. If no light, encoder is bad. Replace motor.
PARK & OSC LED's on monitor control station blink rapidly when button pressed.	Loose encoder wiring connection	Check axis encoder connection
	Bad motor encoder	Interchange motor control boards. Check if problem persists with same axis. If yes, replace motor. Remove encoder cover and check for RED light just below disk. If no light, encoder is bad. Replace motor.
Unable to program PARK pattern.	Program enable timer expired.	Cycle power and enter PARK programming mode within 1 minute
Monitor will not operate from Y4E-COMM communication interface box or Ladder/Platform version electronics enclosure.	Incorrect wiring	Check blue & white communication wiring
	Incorrect INPUTS configuration	Verify DIP switch #4 setting matches system wiring (ON for voltage inputs, OFF for ground inputs).
Y4E-DISP Position Display has all vertical axis or horizontal axis light blinking	No communication with monitor	Check blue/white communication wiring.
	Improper or no programming of monitor stops	Re-teach stops per section 2.8.3
	Programmed travel does not match actual travel of monitor due to: <ul style="list-style-type: none"> • Monitor axis has moved by manual override knobs • Monitor has hit obstruction 	Move monitor axis to each end stop making sure motor current limits.
Y4E-DISP Position Display has one vertical axis light or one horizontal axis light rapidly blinking.	No communication with monitor	Check blue/white communication wiring.

TASK FORCE TIPS, INC.
MADE IN USA • www.tft.com

3701 Innovation Way, IN 46383-9327 USA
800-348-2686 • 219- 462-6161 • Fax 219-464-7155