



HEMISPHERE™ Portable Monitor

INSTRUCTIONS FOR PROPER OPERATION AND MAINTENANCE

⚠ DANGER

Understand manual before use. Operation of this device without understanding the manual and receiving proper training is a misuse of this equipment. Obtain safety information at www.tft.com/serial-number

⚠ WARNING

Sudden change in monitor position of an insecurely installed monitor can result in impact or water sprayed in unintended directions causing injury or death. Verify the mount and monitor are correctly and securely installed on an object capable of supporting reaction force and torque under maximum flow conditions.

NOTICE

This Instruction Manual is intended to familiarize firefighters and maintenance personnel with the operation, servicing, and safety procedures associated with the portable monitor, and should be kept available to all operating and maintenance personnel.

MAXIMUM PRESSURE
175 PSI (12 BAR)
AT NOZZLE WHILE FLOWING
MAXIMUM FLOW
500 GPM (2000 l/min)

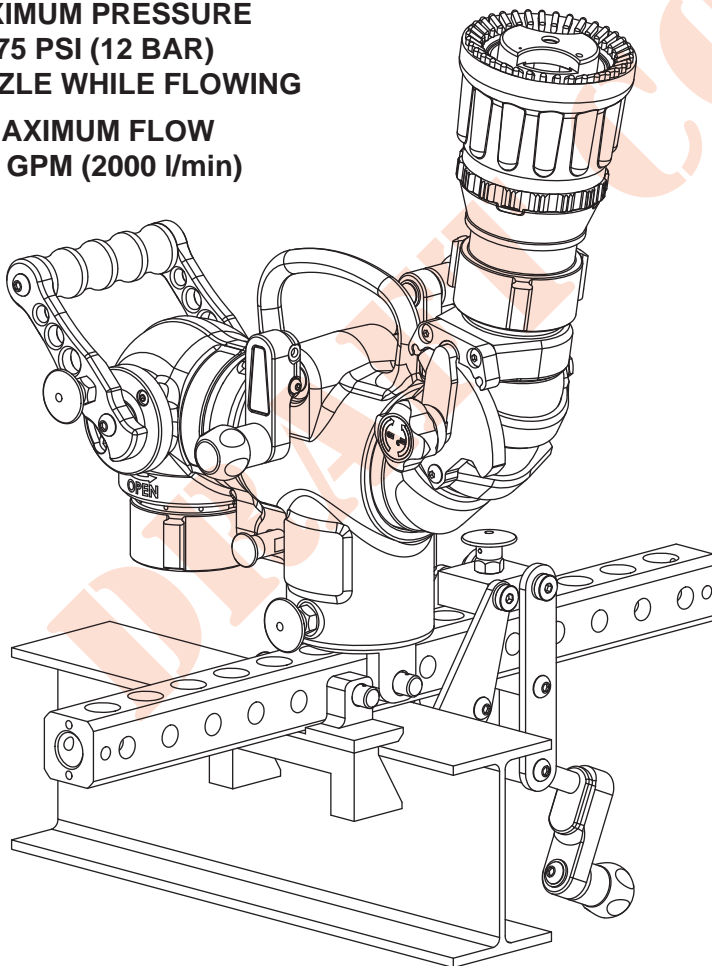

HEMISPHERE monitor, shown with **HPM-A I-BEAM CLAMP ASSEMBLY** and **MAX-FORCE** nozzle

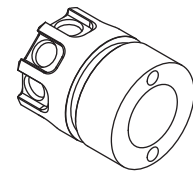

HPM-B FIXED MOUNT

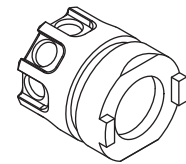

HPM-C HITCH MOUNT

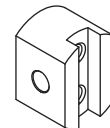

HPM-D MOUNTING BLOCK

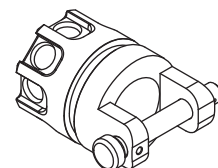

HPM-E CROSS-PIN MOUNT

Patent Pending

TASK FORCE TIPS, INC.
MADE IN USA • www.tft.com

3701 Innovation Way, Valparaiso, IN 46383-9327 USA
800-348-2686 • 219-462-6161 • Fax 219-464-7155

Table Of Contents

- 1.0 MEANING OF SAFETY SIGNAL WORDS
- 2.0 GENERAL INFORMATION
 - 2.1 HEMISPHERE PART IDENTIFICATION
 - 2.2 INSTALLING CLAMPS AND MOUNTS
 - 2.2.1 I-BEAM CLAMP/2" HITCH MOUNT
 - 2.2.1.1 I-BEAM CLAMP MOUNTING
 - 2.2.1.2 2" HITCH RECEIVER MOUNTING
 - 2.2.2 HITCH MOUNT
 - 2.2.3 FIXED MOUNT
 - 2.2.4 MOUNTING BLOCK
 - 2.2.5 CROSS-PIN MOUNT
 - 2.3 INSTALLING THE MONITOR ONTO THE BASE
 - 2.3.1 RELEASING THE MONITOR FROM THE BASE
 - 2.3.2 DROP PREVENTION MECHANISM
 - 2.3.3 ROTATING THE MONITOR ABOUT THE BASE
 - 2.3.4 SAFETY MECHANISM
 - 2.4 POINTING THE NOZZLE
 - 2.4.1 HEMISPHERE COVERAGE
 - 2.4.2 PIVOTING THE OUTLET
 - 2.4.3 LOCKING THE OUTLET PIVOTS
 - 2.4.4 ROTATING THE WATERWAY
 - 2.4.5 QUARTER TURN VALVE
- 3.0 FLOWS AND PRESSURES
 - 3.1 AUTOMATIC, FIXED, AND SELECTABLE FLOW NOZZLES
 - 3.2 STACKED TIPS OR SMOOTHBORE NOZZLES
 - 3.3 STREAM STRAIGHTENERS
 - 3.4 USE WITH FOAM
 - 3.5 USE WITH SALT WATER
 - 3.6 HEMISPHERE PRESSURE LOSS
- 4.0 MAINTENANCE
 - 4.1 DOUBLE BALL PIVOT SYNCHRONIZER AND LOCK MAINTENANCE
 - 4.2 LOCK PIN ASSEMBLY
- 5.0 EXPLODED VIEW AND PARTS LIST
- 6.0 WARRANTY

DANGER

PERSONAL RESPONSIBILITY CODE

The member companies of FEMSA that provide emergency response equipment and services want responders to know and understand the following:

1. Firefighting and Emergency Response are inherently dangerous activities requiring proper training in their hazards and the use of extreme caution at all times.
2. It is your responsibility to read and understand any user's instructions, including purpose and limitations, provided with any piece of equipment you may be called upon to use.
3. It is your responsibility to know that you have been properly trained in Firefighting and /or Emergency Response and in the use, precautions, and care of any equipment you may be called upon to use.
4. It is your responsibility to be in proper physical condition and to maintain the personal skill level required to operate any equipment you may be called upon to use.
5. It is your responsibility to know that your equipment is in operable condition and has been maintained in accordance with the manufacturer's instructions.
6. Failure to follow these guidelines may result in death, burns or other severe injury.



Fire and Emergency Manufacturers and Service Association
P.O. Box 147, Lynnfield, MA 01940 • www.FEMSA.org

1.0 MEANING OF SAFETY SIGNAL WORDS

A safety related message is identified by a safety alert symbol and a signal word to indicate the level of risk involved with a particular hazard. Per ANSI standard Z535.6-2006, the definitions of the four signal words are as follows:

⚠ DANGER

DANGER indicates a hazardous situation which, if not avoided, will result in death or serious injury.

⚠ WARNING

WARNING indicates a hazardous situation which, if not avoided, could result in death or serious injury.

⚠ CAUTION

CAUTION indicates a potentially hazardous situation which, if not avoided, may result in minor or moderate injury.

NOTICE

NOTICE is used to address practices not related to personal injury.

2.0 GENERAL INFORMATION

The Hemisphere is a versatile, lightweight, and quick to deploy portable monitor that gives the user the ability to quickly establish water flow in locations that ground monitors cannot. Since the Hemisphere doesn't rely on gravity for stability, it can be pointed horizontal and down, in addition to up, unlike portable ground monitors. The rotating, pivoting waterway, allows the stream to be pointed in virtually any direction, within a hemispherical range, without interrupting water flow. A variety of mounts, including an I-beam clamp that doubles as a 2" hitch mount, a dedicated hitch mount, and fixed mounts, provide the user the ability to quickly attach the monitor, and establish coverage on the fire ground, or in preplanned locations. An integrated, quarter turn, hardcoat anodized aluminum half ball valve, with locking bail handle, provides shutoff capability. The main and valve bodies are hardcoat anodized aluminum inside and out, with a blue TFT powder coat finish, on the outside. General product specifications are as follows:

- Standard Inlet Coupling: 2 ½ inch NH Female
- Standard Outlet: 2 ½ inch NH male
- Flow range: up to 500 GPM (2000 LPM)
- Maximum pressure at nozzle while flowing: 175 PSI (12 BAR)
- Mounting Positions: 8 positions, every 45 degrees (shutdown to reposition)
- Double Ball Pivot Sweep: 80 degrees (while flowing)
- Main Waterway Rotation: 360 degrees (while flowing)
- Hose Approach: 90 degree inlet valve rotates 360 degrees
- Size, monitor, without nozzle, I-beam clamp, or mounts: 25.5"L x 8.1"W x 10"H (650x210x260mm)
- Weight: 22 lbs (10 kg) (without nozzle, I-beam clamp, or mounts)

⚠ WARNING

This equipment is intended for use by trained personnel for firefighting. Its use for other purposes may involve hazards not addressed by this manual. Seek appropriate guidance and training to reduce risk of injury.

⚠ WARNING

An out of control monitor can cause injury or death. Risk can be reduced by:

- Carefully select structural members for monitor mounting which are capable of safely resisting reaction forces which can be as high as 350 lbf (160 kg)
- Do not attempt to remove the monitor from its clamp or mounting block while flowing.
- Do not attempt to re-position the monitor on its 8 position mount while flowing
- Do not attempt to readjust the I-beam clamp while flowing
- Immediately retreat to a safe distance if the clamp or mount does not appear secure
- Shut down the water hose at its source before attempting to re-secure the monitor

⚠ WARNING

Interrupting flow to the monitor may cause injury or death. Avoid situations that may interrupt flow to the monitor such as: hose line kinks, traffic running over hose, and automatic doors or devices that can pinch the hose.

⚠ CAUTION

Master streams are powerful and capable of causing injury and property damage. Make sure the monitor is pointing in a safe direction before water to the nozzle is turned on. Use care in directing the stream.

⚠ CAUTION

Monitor must be properly connected to hose and nozzle. Mismatched or damaged threads may cause leaking or uncoupling under pressure and could cause injury.

⚠ CAUTION

Do not couple aluminum to brass. Dissimilar metal coupled together can cause galvanic corrosion that can result in inability to unscrew threads or complete loss of thread engagement over time.

2.1 HEMISPHERE PART IDENTIFICATION

The Hemisphere can be mounted on a variety of mounts, each of which includes a standard profile that the Hemisphere attaches to. Figure 2.1 identifies the various parts and controls on a standard Hemisphere portable monitor and HPM-A I-beam clamp/2" hitch mount.

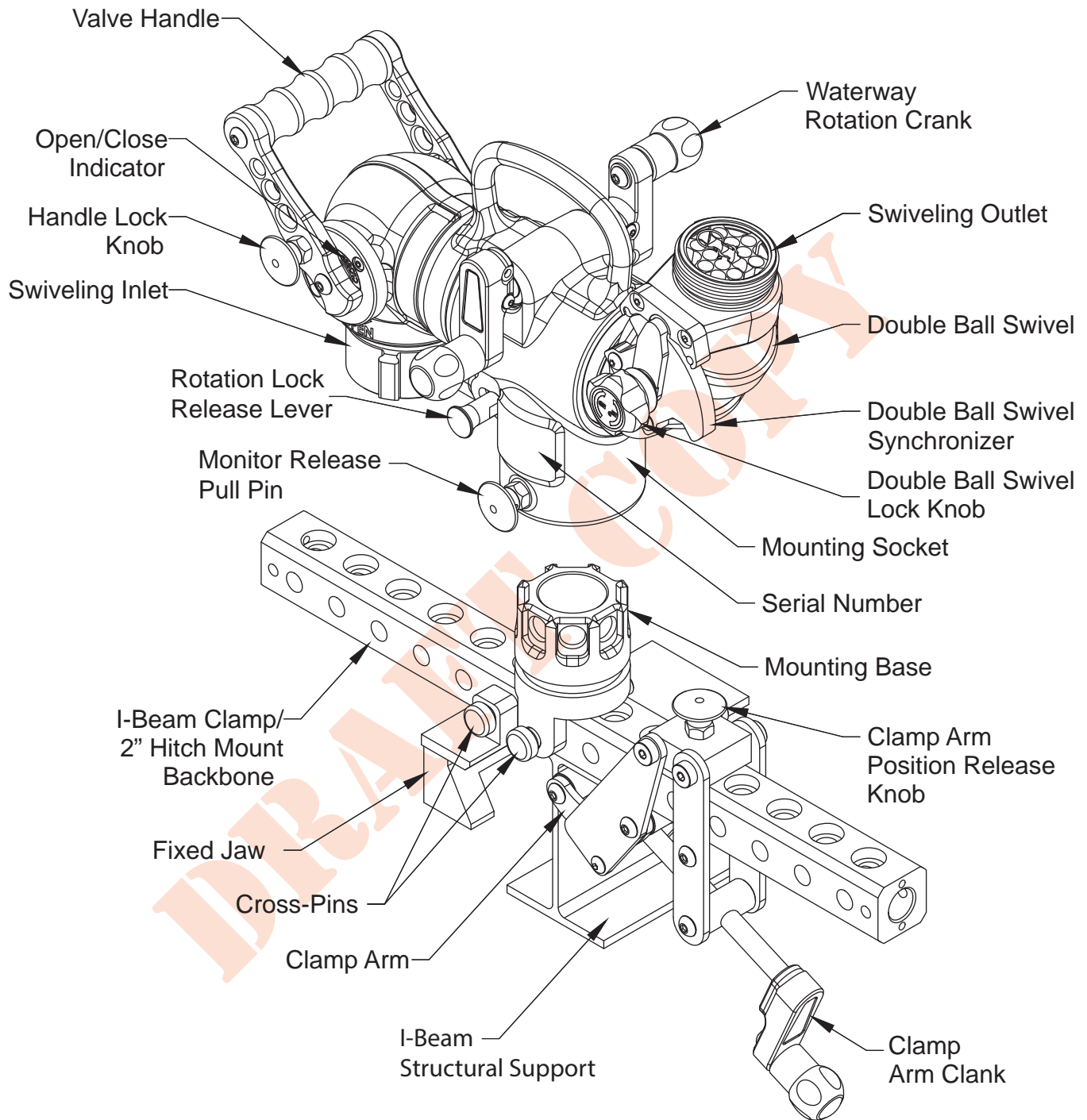

Figure 2.1 Identifies the Various Parts and Controls on a Standard Hemisphere Portable Monitor and HPM-A I-Beam Clamp/2" Hitch Mount

2.2 INSTALLING CLAMPS AND MOUNTS

⚠ WARNING

Monitor clamps and mounts installed on poor or weak objects can become unstable causing an out of control monitor resulting in injury or death. Choose robust stationary objects capable of safely supporting monitor reaction force, torques, hose load, and vibration.

The Hemisphere I-beam clamp is designed primarily for I-beams, but can be installed on other suitable objects, provided the mounted object's geometry and strength are such that the reaction forces and weight of the monitor, water, and attached hose are safely constrained. Consideration should be given to the ability of the mounted object to support loads created as a result of the weight of the monitor, with charged hose, and attachments, such as nozzles, foam eductors, etc..., and torque produced by reaction force and charged hose. An example of a potentially unsafe object would be a process pipe that hasn't been internally inspected, and could have thin walls due to internal corrosion/erosion. Another unsafe example could be using the I-beam clamp to attach to an I-beam with fireproofing that could break off and allow the clamp to become dislodged. The most reliable object is one that has been load tested under actual operating conditions.

2.2.1 I-BEAM CLAMP/2" HITCH MOUNT

The I-beam clamp/2" hitch mount provides a versatile solution for mounting the Hemisphere. With the ability to clamp, as well as attach to a 2" hitch receiver, this mount can get the Hemisphere in locations that other monitors cannot.

2.2.1.1 I-BEAM CLAMP MOUNTING

Before attaching to an I-beam, or other suitable object, the clamp must first be configured to position the monitor in relation to the mounted object. Care must be taken to allow the monitor unobstructed access to the fire, and the user unobstructed access to the monitor controls. The direction the monitor should ultimately point, clearance for the hose, and the ability to rotate to where you may want the monitor to point later, should all be considered. Figure 2.2 shows the clamp components and installation layout. The mount base and fixed end include detented cross-pins, with travel stops to prevent the pins from being dropped or lost. The backbone is designed, such that the mount base and the fixed jaw can be attached at any of the 30 cross holes, including both above and below, for a total of 60 possible positions. Although all 60 positions are possible, they may not all make sense for certain applications. The angled face of the fixed jaw should be aligned opposite the clamp arm, as shown. If the fixed jaw is installed in the wrong orientation, the clamp will not hold. Be sure to install the fixed jaw far enough away from the clamp arm to allow the I-beam, or other suitable mounting object, to fit into the clamp.

When assembling the I-beam clamp, ensure that the larger 1" [25 mm] holes are aligned parallel with the pull-pin on the clamp arm assembly, as shown. The clamp arm assembly should be **fully retracted**, by rotating the crank counterclockwise, and slid onto the backbone until it clicks and seats in the first hole.

Upon verifying that all components are properly installed and secure, the clamp is ready to install.

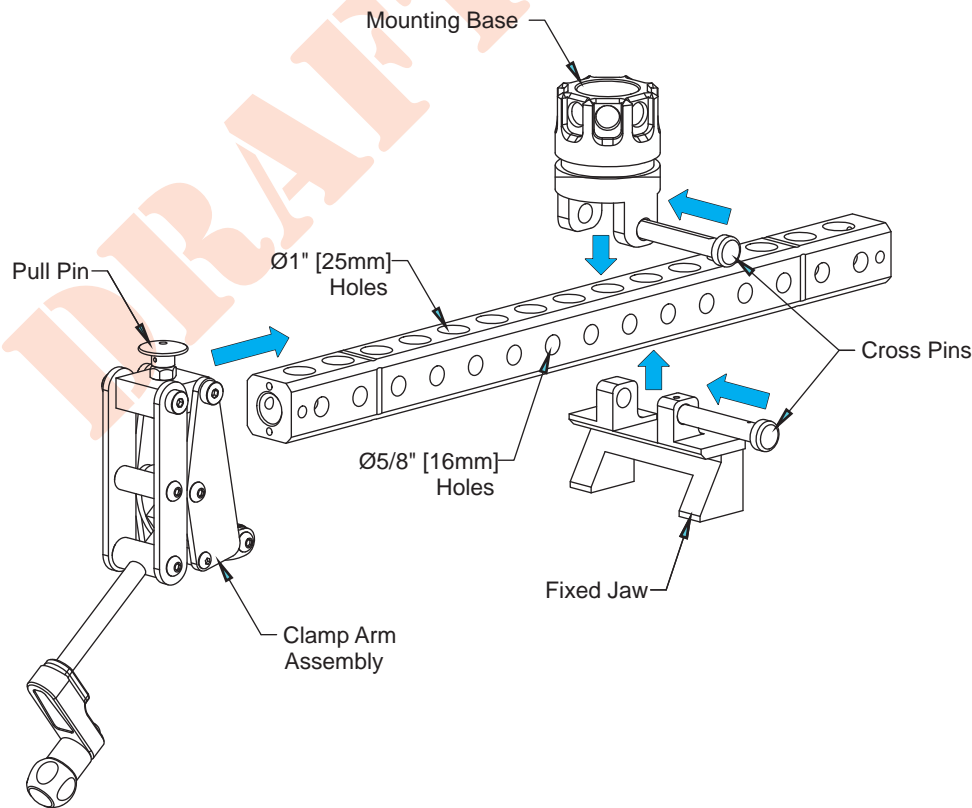

Figure 2.2 I-Beam Clamp Assembly

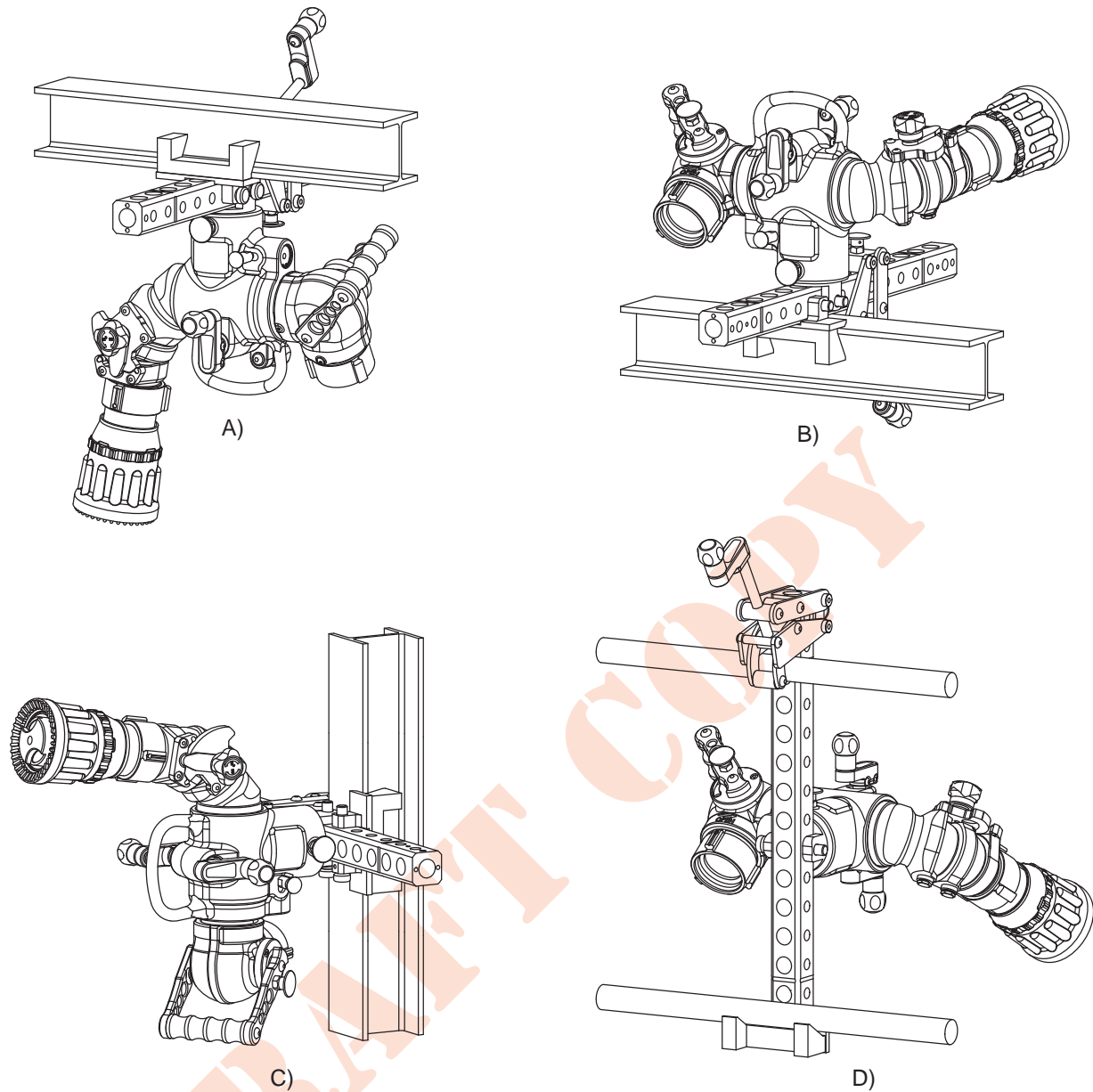

Figure 2.3: Several different possible mounting orientations

Several orientations are possible when clamping to I-beams, stair rails, and other suitable geometry. Figure 2.3 shows some examples of possible orientations. Different orientations may make more sense than others, depending on what direction the nozzle will need to point, and available space. The vertical mounting in figure 2.3C, for example, would make more sense than the horizontal mounting in figure 2.3B if a wide range of horizontal movement is needed, and the stream won't need to point below horizontal. The mounting in 2.3B would make more sense if a wide range of vertical movement, with below horizontal movement anticipated, and the quick sweeping ability of the double ball swivel is useful in the horizontal orientations, as shown. Figure 2.3D shows the I-beam clamp attached to a hand rail.

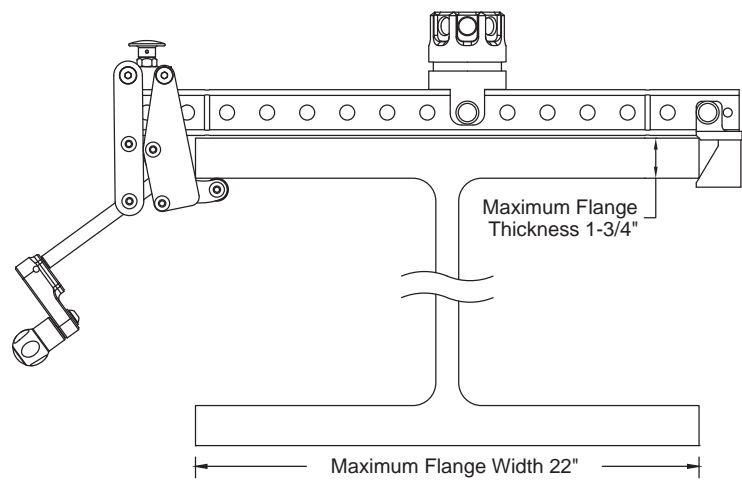

Figure 2.4 Maximum Flange Dimensions

▲ DANGER

Exceeding the maximum flange thickness creates an unsafe operating condition, and will compromise the ability of the clamp to maintain a fixed position, resulting in an out of control monitor. An out of control monitor can cause injury, death, and/or property damage.

Step 1

With the clamp arm fully retracted, position the fixed jaw against the I-beam, as shown in figure 2.5. Push the clamp arm toward the I-beam. Clicks should be heard, as the lock pin seats and ramps out of the cross holes.

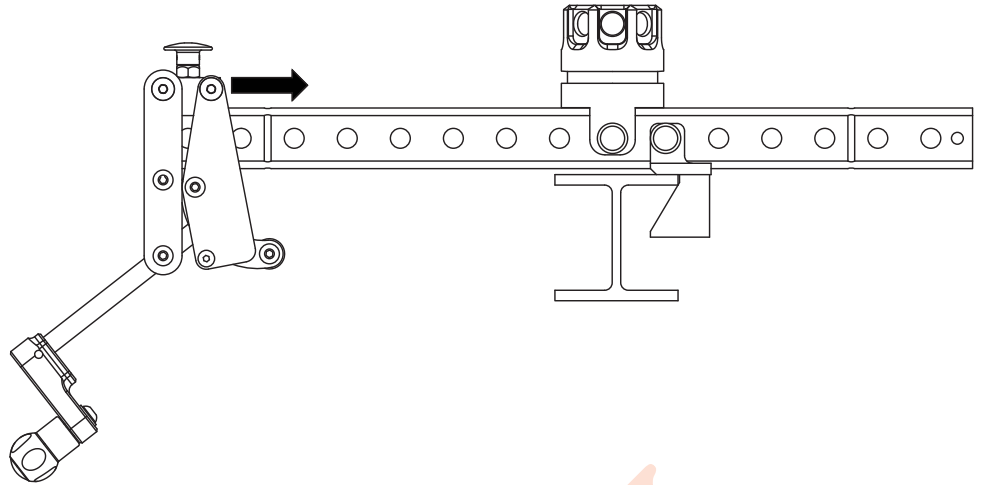

Figure 2.5 I-beam clamp installation Step 1

Step 2

When the edge stop contacts the edge of the I-beam, as shown in figure 2.6, pull the clamp arm back to the next closest cross hole.

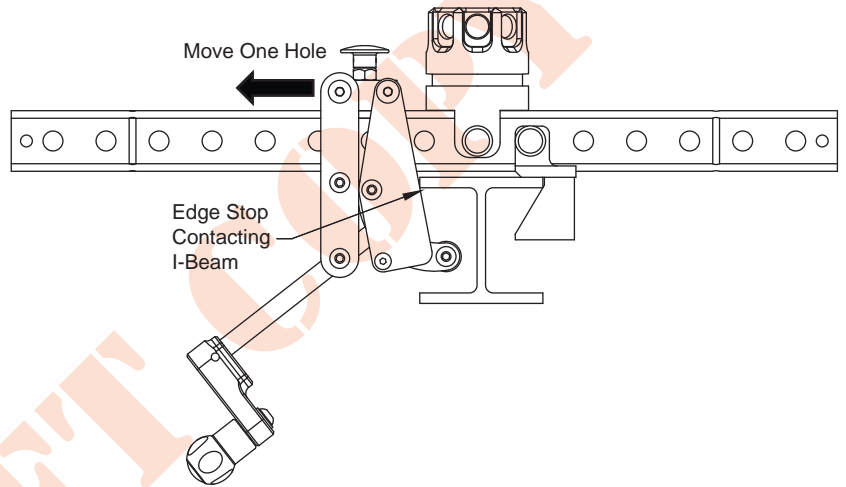

Figure 2.6 I-Beam Clamp Installation Step 2

Step 3

When the lock pin clicks into place on the backbone, as shown in figure 2.7, rotate the crank clockwise, to engage the clamp arm, until it is snug.

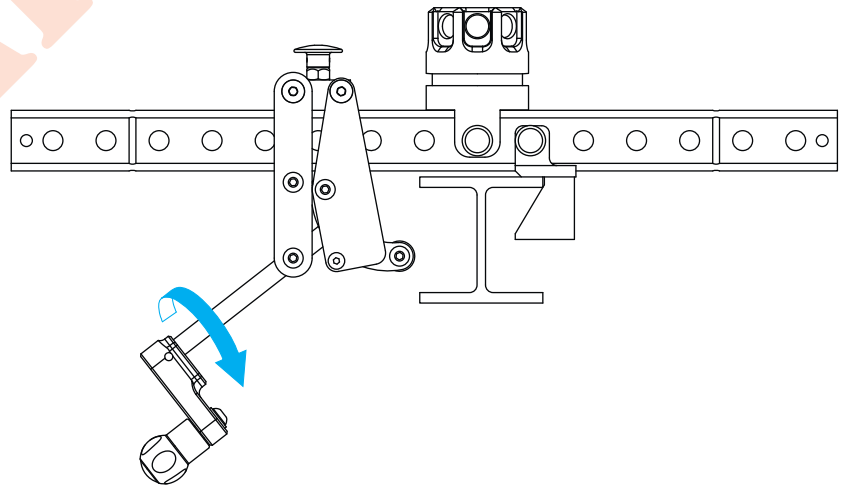

Figure 2.7 I Beam Clamp Installation Step 3

Step 4

Rotate the crank one full turn past snug, as shown in fig 2.8, and attempt to shake the clamp assembly. If the clamp is able to move in relation to the mounted object, rotate the crank until the clamp is firmly seated against the I-beam. After use: Ensure clamp is fully retracted (unscrewed) for storage.

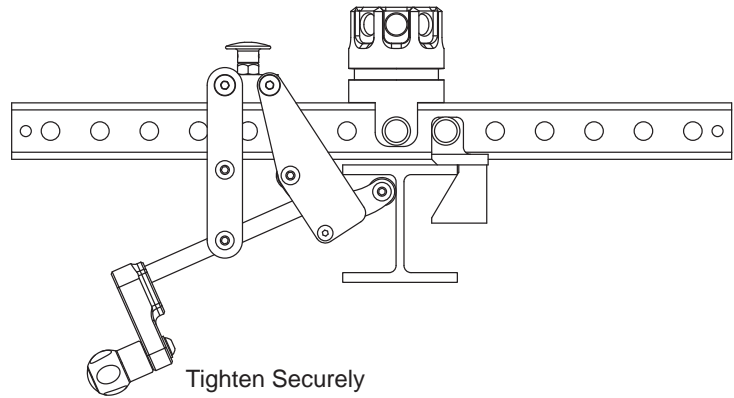

Figure 2.8 I-Beam Clamp Installation Step 4

⚠ WARNING

Overtightening the I-beam clamp can distort or damage the clamp resulting in an insecure monitor mounting that will not safely support reaction forces. Don't turn crank more than one turn after the clamp arm is fully seated and arm has stopped moving. Don't tighten the crank with a wrench, tool, or cheater bar.

2.2.1.2 2" HITCH RECEIVER MOUNTING

The backbone for the I-beam clamp is sized to fit into any standard 2" x 2" Class III or Class IV hitch receiver, and the crosssholes are sized to accept a standard 5/8" [16mm] hitch pin, allowing instant attachment to hitch receiver equipped vehicles. The clamp arm and fixed jaw are not needed when installed in a hitch, but they can be left on, if convenient. The same mount base used when attaching to I-beams is used when mounting to a hitch receiver. Be sure that the backbone is fastened to the hitch receiver with a hitch pin, and the hitch pin is retained by a cotter-pin or other retention device before charging the hose line.

⚠ CAUTION

Cross pin must be installed and secured before charging hose or flowing monitor.

2.2.2 HITCH MOUNT

The hitch mount is designed to be installed on a standard 2" class III hitch. The hitch ball, nut, and lock washer must first be removed. The hitch mount washer is then inserted into the mount, and the mount is placed flush against the hitch tongue, with the alignment tabs on the sides, on the side opposite of the desired position of the ball. Be sure that the tongue won't interfere with the monitor. Insert the hitch ball through the tongue and hitch mount washer. Fasten the nut and lock washer to the hitch ball. The mount can be left in place while towing, provided sufficient clearances from the ground and other objects exist.

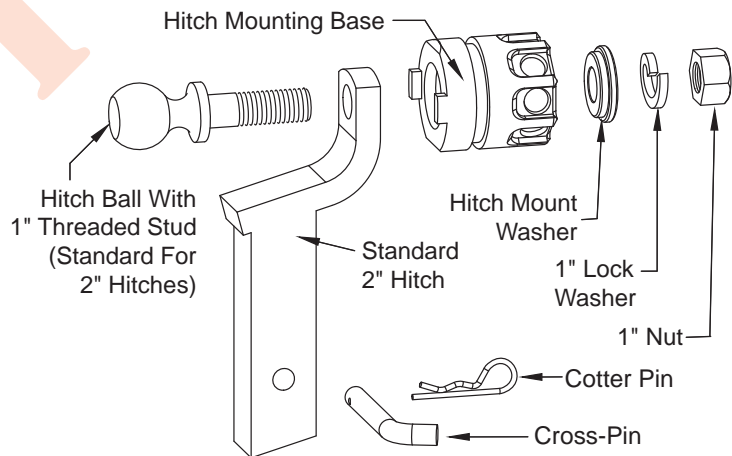

Figure 2.9 Hitch Mount Installation

2.2.3 FIXED MOUNT

Fixed mounts can be installed in preplanned locations for fast, precise setup. Two (2) 1/2"-20 screws, with washers, spaced 2.69" [68mm] apart are required (not included), and are installed from the back side of a mounting surface that has been pre-drilled with two (2) .52" [13mm] clearance holes. The screws must be long enough to engage at least .75" [19mm], and no more than 1" [25mm] into the tapped holes on the mount. The mounting surface and fasteners must be able to support the weight of the monitor and all attachments, including the water contained within the monitor and hoses, and also the torque resulting from the reaction forces and hoses.

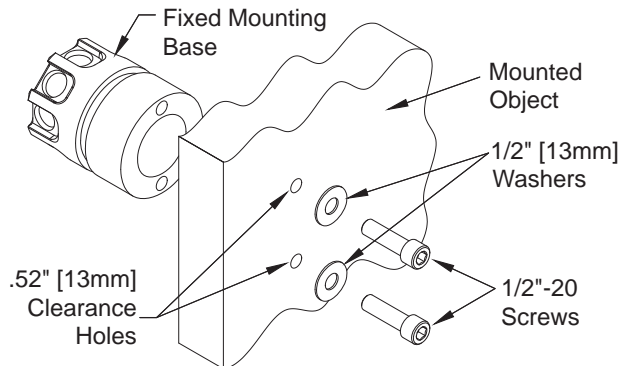

Figure 2.10 Fixed Mount Installation

2.2.4 MOUNTING BLOCK

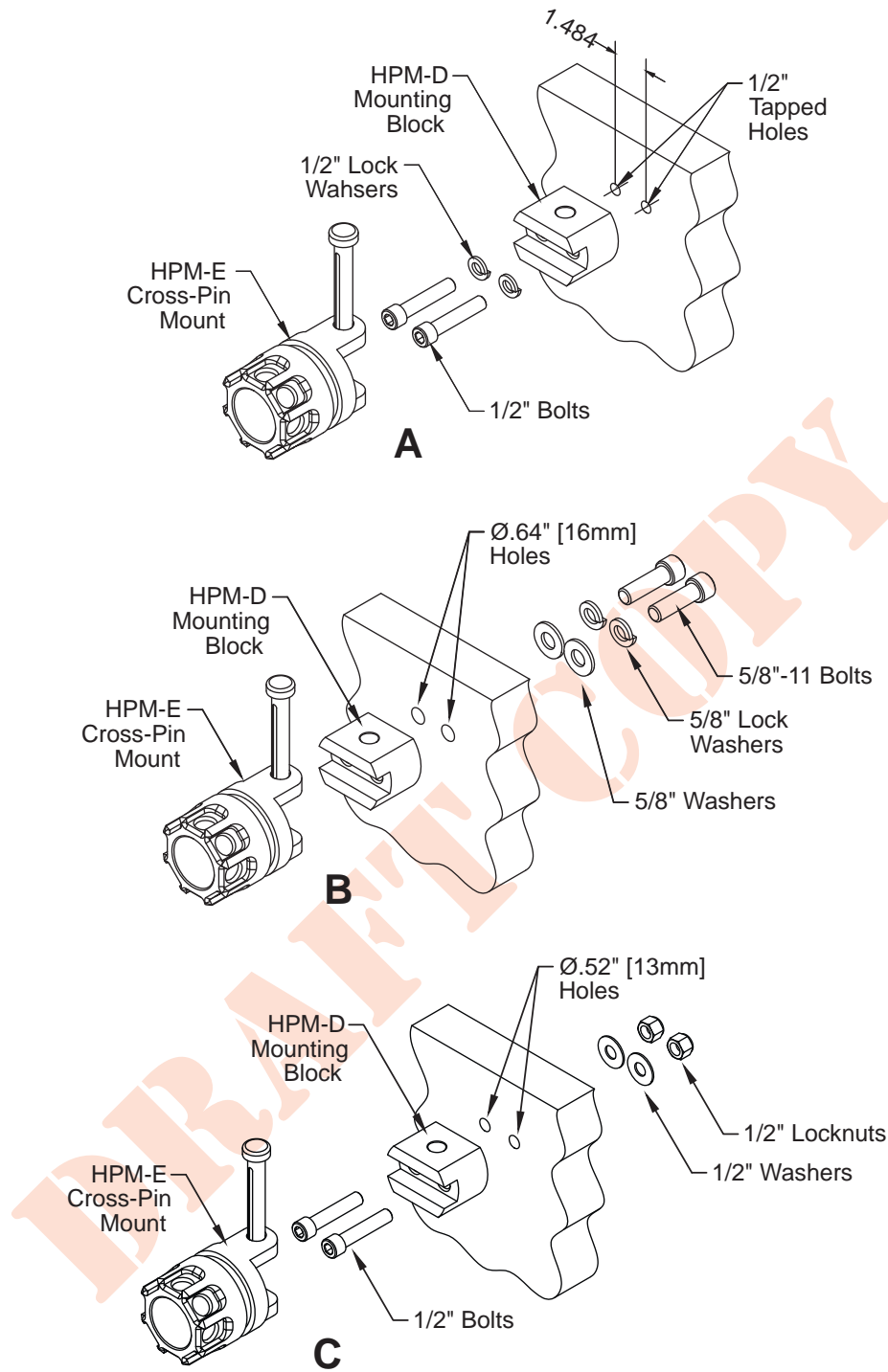

Figure 2.11 Mounting block installation options

A mounting block can be used as a fixed mount, for flowing, or as a storage bracket for the Hemisphere monitor. This mount can be used in locations where the back side of the mounting surface is inaccessible. It can be bolted from the front of a sufficiently rigid surface by adding two 1/2" [13mm] tapped holes (See figure 2.11 a.) It can also be bolted from the back side of a surface, by drilling two (2) .64" [16mm] clearance holes (See figure 2.11 b.) and screwing two (2) 5/8"-11 bolts into the tapped holes on the bracket. A third option would be to drill two (2) .52" holes, and bolting the mounting block from the front side with 1/2" bolts, washers, and locknuts (See figure 2.11 c.)

2.2.5 CROSS-PIN MOUNT

A cross-pin mount can be added to a mounting block to create a monitor-ready attachment location (See Figure 2.11.) It is the same mount base that is included with the I-beam clamp/2" hitch mount, with the same detented cross-pin, and can be ordered as a spare or replacement.

2.3 INSTALLING THE MONITOR ONTO THE BASE

The Hemisphere monitor is designed to be installed by one person, with minimal effort, by sliding the socket at the base of the monitor onto a mount base. The monitor is not attached until the monitor release pin seats in the annular groove on the lower portion of the mount base (see fig. 2.12). **Attachment should always be verified by attempting to pull the monitor off the base.** It is recommended that the mount be in place and secured before attaching the monitor. The monitor can be installed with or without a hose attached, but it often requires less effort to line up and orient the monitor without an attached hose.

2.3.1 RELEASING THE MONITOR FROM THE BASE

The monitor release knob retracts the monitor release pin from the annular groove in the mount base. The release pin includes a mechanism that prevents an unsupported monitor from releasing. It is recommended that the hose be depressurized and removed before releasing the monitor.

2.3.2 DROP PREVENTION MECHANISM

The drop prevention mechanism is engaged when the monitor base is under tension as a result of the weight of a hanging upside down monitor, or any other forces that create tension between the base and monitor that could cause an uncontrolled release of the monitor from the base. Illustrations of cross-sections through the mechanism are shown in figs. 2.13 & 2.14. In fig. 2.13, it can be seen that the gravity pulling on the unsupported monitor pushes the lock pin off-center, and prevents the monitor release knob from moving the lock pin out of the annular groove. Fig. 2.14 shows that by supporting the weight of the monitor, the lock pin is pushed into alignment with its bore. Pulling the monitor release knob moves the lock pin out of the annular groove, and allows the monitor to be removed from its base. The lock pin should be inspected and cleaned regularly, to ensure reliable operation.

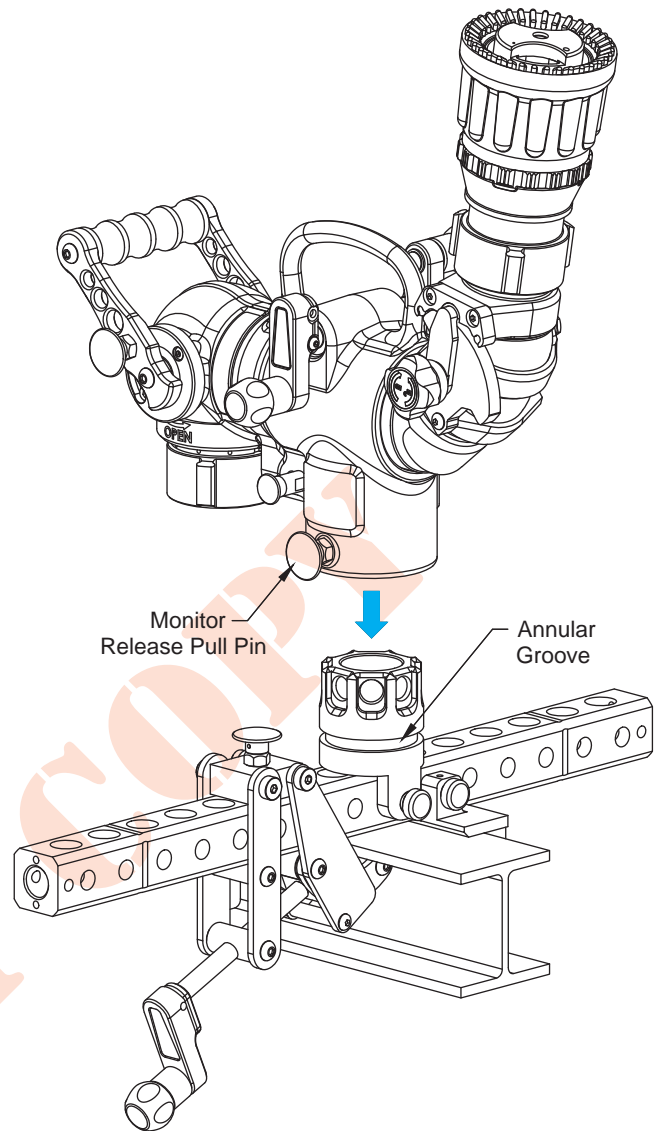

Figure 2.12 Attaching the monitor to the mount base

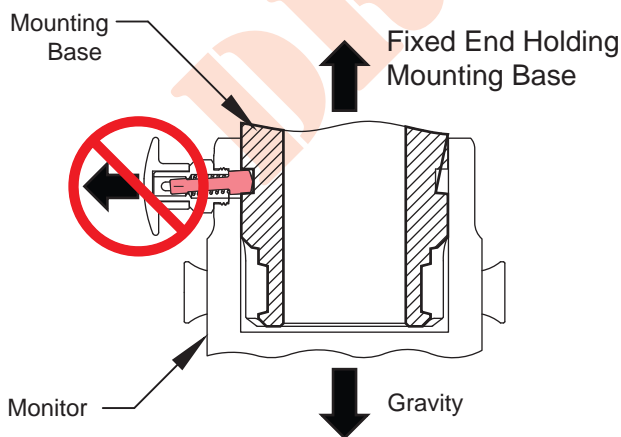

Figure 2.13 Unsupported Monitor with Lock Preventing the Monitor Release Knob from Being Pulled

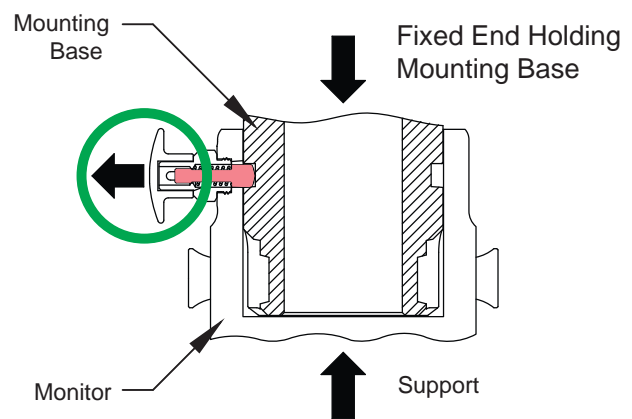

Figure 2.14 Supported Monitor with Lock Disengaged; Ready to Release

⚠️ WARNING

Do not force the rotation lock release lever or attempt to reposition the monitor on its base while flowing. Reaction forces generated from the flow of water through this monitor can be as high as 350 lbf (160 kg), and can cause the monitor to become unstable or even out of control if the safety mechanism becomes compromised. To reduce risk of injury or death from an out of control monitor, verify that the safety mechanism is not compromised.

2.3.3 ROTATING THE MONITOR ABOUT THE BASE

Once the monitor is secured to the base, it may be necessary to reorient the monitor. Rotation lock release levers (see fig. 2.15), on both sides of the monitor, provide the ability to rotate the monitor about its base in 45 degree increments, provided the monitor is not flowing. If the rotation lock release lever is pulled while flowing, a pressurized chamber behind the pin prevents it from unlocking.

2.3.4 SAFETY MECHANISM

The hemisphere has a safety mechanism that stops the monitor top from being released while flowing. The safety device is pressure activated to push the rotation lock pin (red) into the holes on the base whenever the monitor is pressurized. Pulling back on the rotation lock release lever should not defeat the safety mechanism.

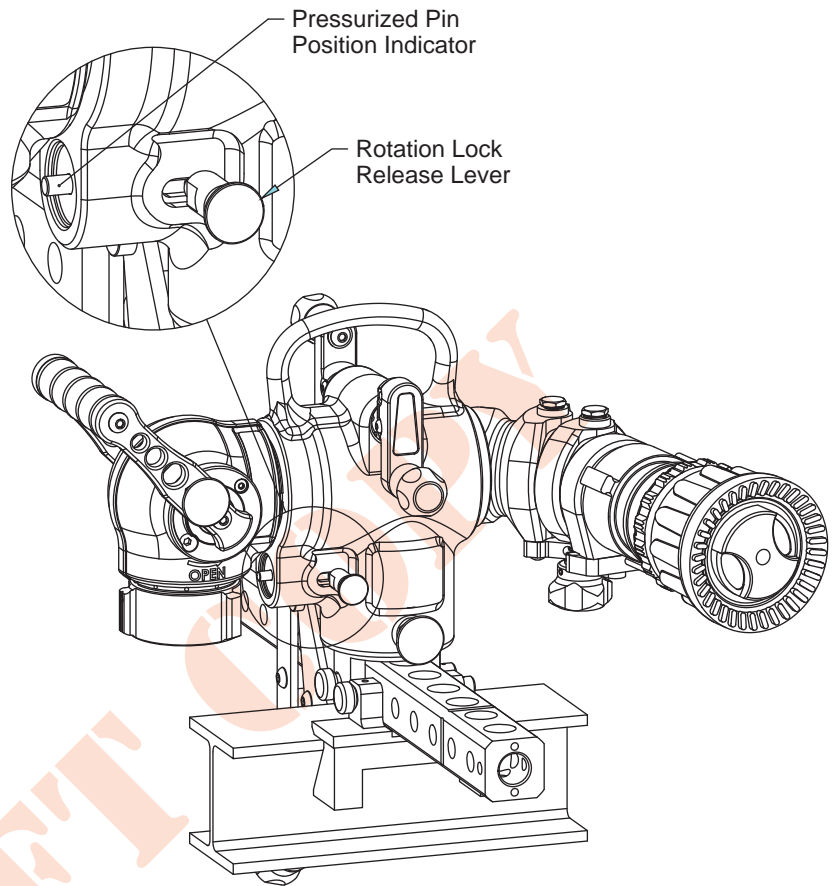

Figure 2.15 Monitor mounted on an I-beam showing the position of the lock release lever and indicator pin.

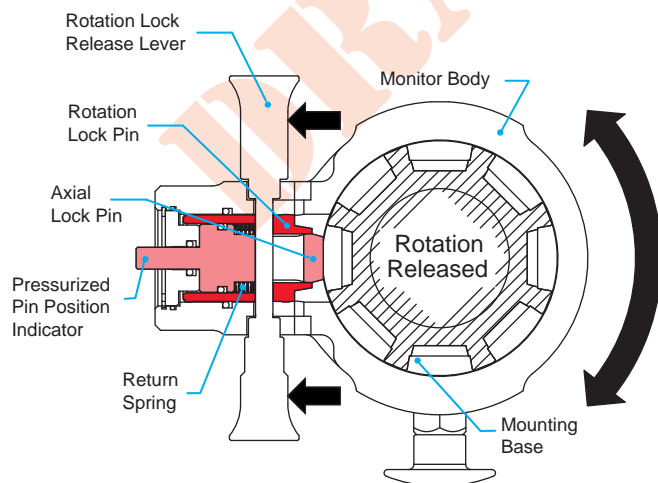

Figure 2.16 Cross-Section Showing Rotation Lock Lever Pulled Back, Allowing the Monitor to Rotate about Its Base

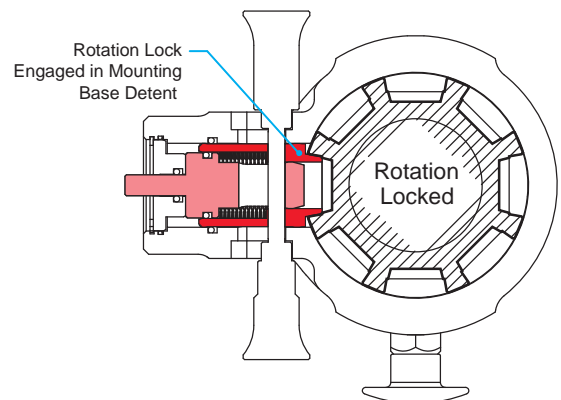

Figure 2.17 Rotation Lock Lever Released; Monitor Cannot Rotate about Its Base

Figure 2.18 shows the pressurized chamber behind the rotation and axial lock pins when the monitor is flowing. See maintenance section 4.2 for pressurized lock pin maintenance information.

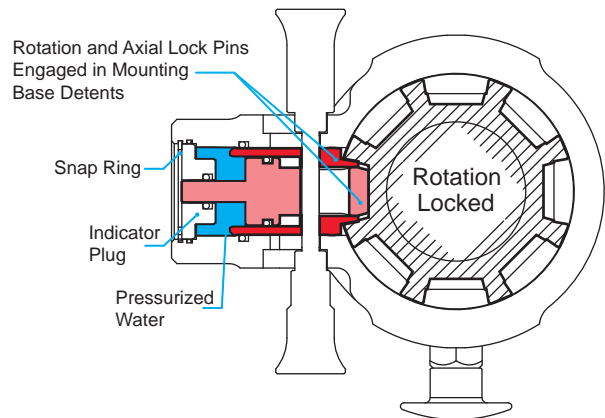

Figure 2.18 Rotation Lock Lever Released; Monitor Flowing; Rotation Lock Lever is Prevented From Being Pulled

2.4 POINTING THE NOZZLE

Once the mount is secured, the monitor is secured to the mount, and the hose is in place, the initial nozzle flow direction must be established. The Hemisphere has a double ball pivot mechanism that incorporates synchronizing geometry to prevent reaction forces from influencing the flow direction. This allows the double ball pivot assembly to provide twice the sweep of a single ball, a full 80 degree range of motion. The double ball pivot is normally loose, and easy to position, without the lock engaged. Additional resistance can be added by turning the lock knob until the desired resistance is achieved. To maintain a fixed position, the lock knob can be tightened all the way down.

In addition to the 80 degrees of sweep provided by the pivoting outlet, the angled waterway, to which the double ball pivot is attached, can be rotated a full 360 degrees with no travel stops.

Additional information about pivoting the outlet can be found in section 2.4.2, and information about rotating the waterway is in 2.4.4.

2.4.1 HEMISPHERE COVERAGE

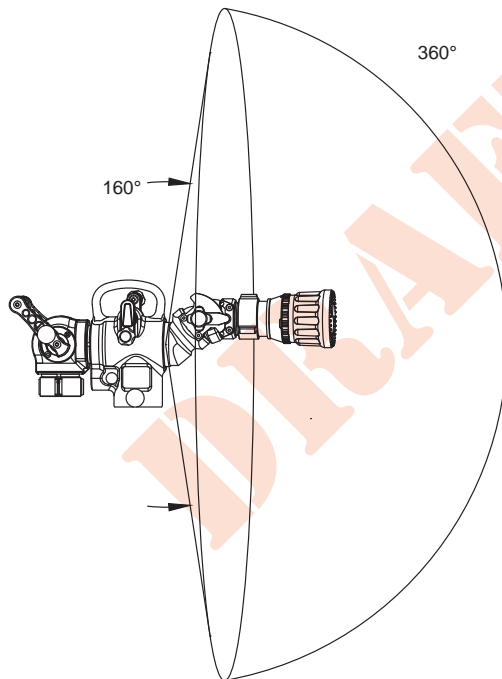

Figure 2.19 Graphic Illustrating the range of possible nozzle orientations, while flowing, combining main waterway rotation, with double ball sweep (water flow does not need to be interrupted to achieve these rotations.)

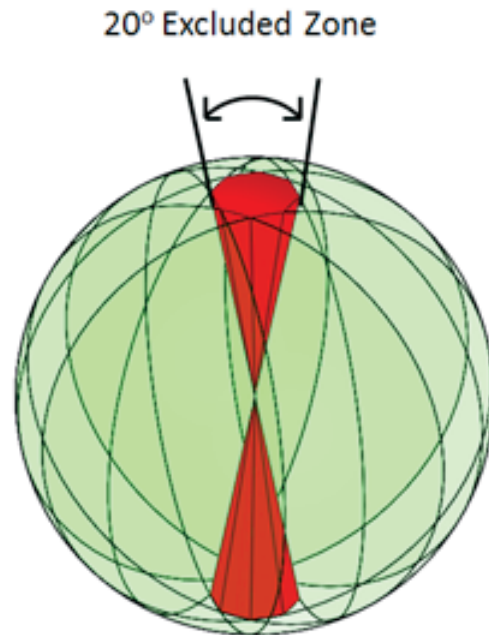

Figure 2.20 Graphic Illustrating the range of possible nozzle orientations, combining main waterway rotation, with double ball sweep, and 45 degree incremental rotations about the monitor base (water flow needs to be interrupted to achieve rotation about the monitor base)

Figures 2.19 and 2.20 show the range of possible directions the Hemisphere nozzle can point overall, through combined rotations about all of its axes. The range shown in figure 2.19, almost a complete hemisphere, is achievable without interrupting water flow. When that range is rotated about the monitor base, without water flowing, any point on a sphere, minus the 20 degree regions above and below the monitor, can theoretically be achieved, as illustrated in Fig.2.20. In practice, however, some regions will be obscured by the mount and/or mounted object.

2.4.2 PIVOTING THE OUTLET

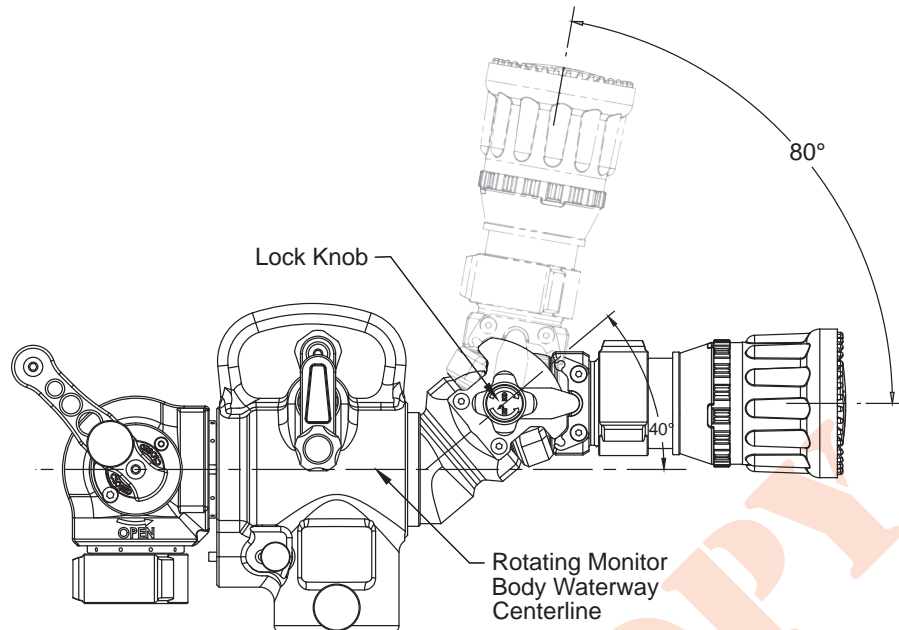

Figure 2.21 Double ball pivot orientation and range of motion.

The outlet is preceded by a double ball pivot that incorporates a synchronizing mechanism. Each pivot is capable of 40 degrees of rotation, resulting in a total of 80 degrees of sweep (see Fig. 2.21.) The 80 degree sweep is centered 40 degrees from the rotating monitor body waterway centerline, allowing the outlet to point parallel to the monitor body waterway centerline, and up to 80 degrees away from the centerline.

The synchronizing mechanism allows the pivot nearest the outlet to be pointed off of the axis of the pivot nearest the monitor body by taking up the part of the reaction force that would tend to rotate the pivot nearest the monitor body.

See section 4.1 for synchronizer maintenance and wear pad repair/replacement information

2.4.3 LOCKING THE OUTLET PIVOTS

Lock the trajectory in position while flowing by hand tightening the lock knob clockwise. Don't use a wrench, tool or cheater bar.

2.4.4 ROTATING THE WATERWAY

The waterway through the monitor body is attached to a double crank shaft by a worm gear, and can be rotated a full 360 degrees. The crank arms come in a standard configuration where the holes closest to the knobs attach to the shaft, and the two crank arms are rotated 180 degrees to each other. The force required to rotate the crank can be reduced by removing the screws holding the crank arm, and moving the crank shaft from the bore closest to the knob to the bore furthest from the knob. Either of the crank arms can also be rotated 180 degrees to make both cranks aligned, if preferred.

2.4.5 QUARTER TURN VALVE

⚠ WARNING

Quick changes in valve position can cause high pressure spikes due to water hammer and may result in damaged equipment which could lead to injury or death. Open and close the valve slowly to avoid water hammer.

⚠ WARNING

Kinks in supply hose may reduce water flow and cause injury or death to persons dependant on water flow. Avoid tight bends to minimize risk of hoseline kinks.

The quarter turn valve incorporates a bail style handle to allow opening/closing from either side. The valve locks in the off position to prevent accidental opening.

3.0 FLOWS AND PRESSURES

The Hemisphere Portable Monitor is designed for maximum flows of 500 GPM (2000 LPM) and a maximum pressure at the nozzle, while flowing of 175 PSI (12 BAR). Do not exceed these limits.

⚠ WARNING

An inadequate supply of pressure and/or flow will cause an ineffective stream and can result in injury, death or loss of property.

3.1 AUTOMATIC, FIXED, AND SELECTABLE FLOW NOZZLES

A variety of water or foam nozzles may be used with the Hemisphere. Automatic nozzles maintain a constant pressure by adjusting their opening to match the available flow. Consult the nozzle manufacturer for maximum flow and pressure ratings. In all cases do not exceed 500 GPM (2000 LPM) and/or 175 PSI (12 BAR) nozzle exit pressure.

3.2 STACKED TIPS OR SMOOTHBORE NOZZLES

NOZZLE DIAMETER	NOZZLE EXIT PRESSURE									
	50 PSI		80 PSI		100 PSI		150 PSI		175 PSI	
	FLOW (GPM)	REACTION (LBS)	FLOW (GPM)	REACTION (LBS)	FLOW (GPM)	REACTION (LBS)	FLOW (GPM)	REACTION (LBS)	FLOW (GPM)	REACTION (LBS)
1.0 INCH	210	80	266	126	297	157	364	236	390	275
1-1/4 INCH	328	120	415	196	464	245	—	—	—	—
1-1/2 INCH	473	177	—	—	—	—	—	—	—	—

NOZZLE DIAMETER	NOZZLE EXIT PRESSURE									
	4 BAR		6 BAR		8 BAR		10 BAR		12 BAR	
	FLOW (L/min)	REACTION (KG)	FLOW (L/min)	REACTION (KG)	FLOW (L/min)	REACTION (KG)	FLOW (L/min)	REACTION (KG)	FLOW (L/min)	REACTION (KG)
25 MM	830	40	1000	60	1200	80	1300	100	1400	120
32 MM	1300	70	1700	100	1900	130	—	—	—	—
38 MM	1900	90	—	—	—	—	—	—	—	—



FLOW EXCEEDS RATING OF HEMISPHERE PORTABLE MONITOR

3.3 STREAM STRAIGHTENERS

Stream quality, especially with smooth bore nozzles, is generally improved with the use of a stream straightener. A stream straightener is integrated into the exit of the monitor.

3.4 USE WITH FOAM

The Hemisphere may be used with various foam nozzles and foam solutions. Refer to fire service training for the proper use of foam.

3.5 USE WITH SALT WATER

Use with salt water is permissible provided the monitor is thoroughly cleaned with fresh water after each use. The service life of the monitor may be shortened due to the effects of corrosion and is not covered under warranty.

3.6 HEMISPHERE PRESSURE LOSS

Figure 3.6 gives the pressure loss for the Hemisphere Portable Monitor

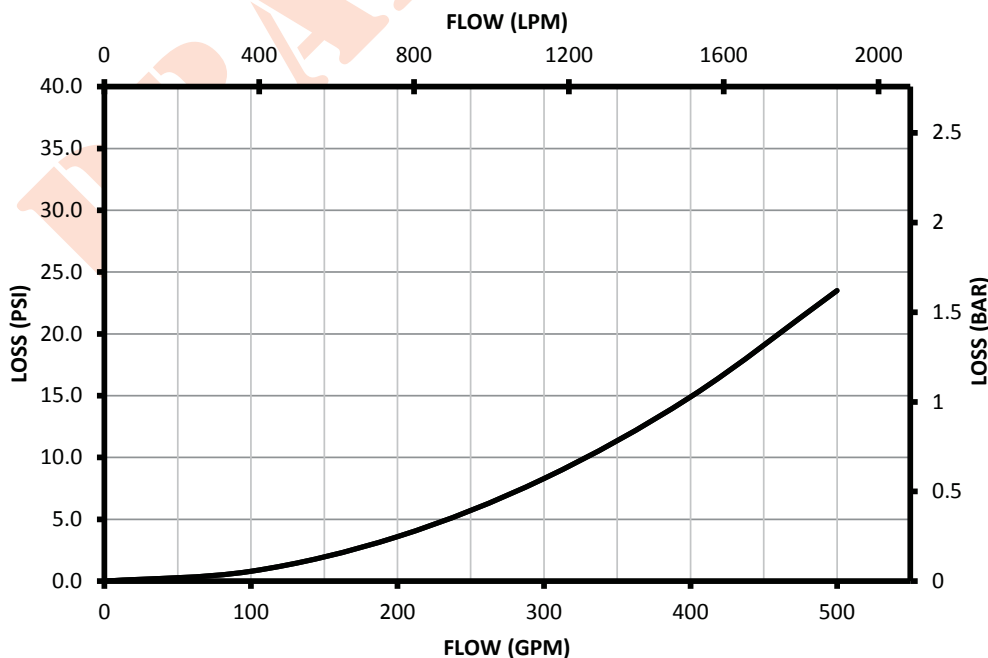

Figure 3.6 Hemisphere Pressure Loss

4.0 MAINTENANCE

The Hemisphere monitor requires little maintenance. The unit should be kept clean and free of dirt by rinsing with water after each use. Any inoperable or damaged part should be repaired or replaced.



Any alterations to the Hemisphere and its markings could diminish safety and constitutes a misuse of this product.

MAINTENANCE CHECK LIST:

- The rotation lock pin can be fully disengaged by pulling one of the rotation lock release levers and is clear of dirt and debris.
- The pressurized pin position indicator can be pushed in flush with the plug.
- Mounting base is not damaged and groove and detents are free of debris.
- I-beam clamp arm slides along the backbone and the crank moves freely.
- Waterway rotation crank moves freely and waterway rotates full 360 degrees.
- Double ball pivots freely up and down.
- Double ball swivel lock knob turns freely and provides enough drag to support the weight of a nozzle.
- Inlet coupling and valve rotate freely.
- Valve handle lock engages and releases.
- Valve handle moves smoothly without binding.
- Valve position indicator label legible.

4.1 DOUBLE BALL PIVOT SYNCHRONIZER AND LOCK MAINTENANCE

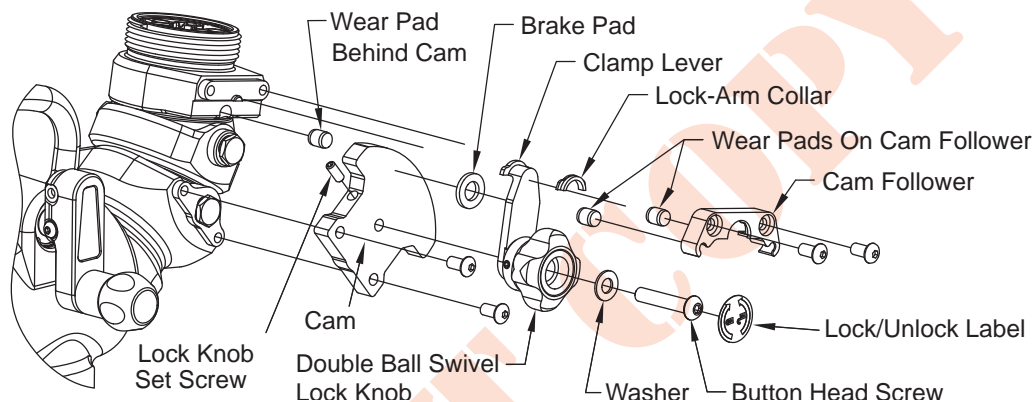

It is important to clean, inspect, and maintain the synchronizing mechanism regularly, and before each use, as needed. The assembly can be brushed clean with soap and water. The mechanism consists of a cam, cam follower, wear pads, and a lock mechanism.

The wear pads are press fit in place, and will need to be maintained periodically. Indications that maintenance is needed include: difficulty rotating the double ball swivel assembly, inability to lock the double balls, and metal to metal contact between the cam follower and the cam. Removing the two pads on the cam follower:

1. Remove the two (2) 5/16" button head screws (with a 3/16" hex wrench) that hold the cam follower in place and remove the cam follower.
2. Secure the cam follower in a soft jaw (or equivalent) vise, and tap with a punch and hammer on the backside of the pads until they are removed.
3. Remove the pad located behind the cam in the pocket on the side of the pivot ball.
4. Remove the cam follower and the cam.
5. Drill the center of the worn pad with a 1/8" drill, to form a pilot hole. Then drill with a 3/8" drill bit. Both drills must be fitted with a travel stop, to prevent the drill from going more than 7/16" into the pad.
6. The remaining pad material can be pried out with a screwdriver or a small pry bar. Replace the pad by tapping a new pad into the bore with a punch and hammer.

The brake pad and lock arm collar should be inspected periodically to ensure that the lock provides sufficient engagement to prevent unwanted nozzle sweep. The brake pad and lock arm collar can be accessed by removing the cam follower and lock arm. Once the cam follower is removed, the lock arm collar can be removed, and the lock arm can be removed by removing the set screw in the side of the cam and unscrewing the lock knob screw that attaches the knob to the cam. The brake pad can be removed by prying it off of the boss it is press fit onto.

Apply Loctite #242 (blue) to all screws before reassembly, except the lock knob screw. Loctite should be applied to the female threads that mate with the lock knob screw on the cam. Do not apply Loctite to the female threads that mate with the lock knob screw on the lock knob. The lock knob screw should be greased with Chuck-eez (or equivalent molybdenum disulfide based grease) on the upper half of the threads only. Any grease on the lower 1/2" of threads should be cleaned with acetone before assembling the screw onto the cam. Once all parts of the lock mechanism, except for the lock/unlock label, are assembled, and before the Loctite sets, rotate the lock knob counterclockwise about the lock knob screw until the head of the screw is snug against the washer and the washer is snug against the lock knob. Rotate the knob/screw clockwise until the knob snugs up against the clamp lever, turn it back 1/4 turn counterclockwise, and tighten the set screw. Verify that the double ball assembly moves freely with the lock knob in the unlock position, and that the ball swivels cannot be moved with the lock/unlock knob in the lock position. Clean any grease off the label groove with acetone and apply a new lock/unlock label.

4.2 LOCK PIN ASSEMBLY

Free movement of the rotational lock pin can be verified by pulling back on the rotation lock pin release lever, and can be verified for the axial lock pin by pressing in on the indicator. The lock pin assembly should be disassembled, inspected, and cleaned if the pins are not functioning properly. Disassembly can be accomplished by using snap ring pliers to remove the snap ring retaining the indicator plug, and two 9/16" open end wrenches to remove one of the rotation lock release levers from the rotation release lever shaft. Damaged or worn pins or o-rings should be replaced. Apply a silicone-based grease such as Dow Corning 112 to all seals prior to installation. Apply a light coat of Chuck-eez (or equivalent molybdenum disulfide based grease) to the pin bores in the monitor body and the rotational lock pin prior to installing the pins. Apply Loctite #242 (blue) compound to the pin retract shaft threads before reinstalling the rotation lock release lever.

DRAFT COPY

5.0 EXPLODED VIEWS AND PARTS LISTS

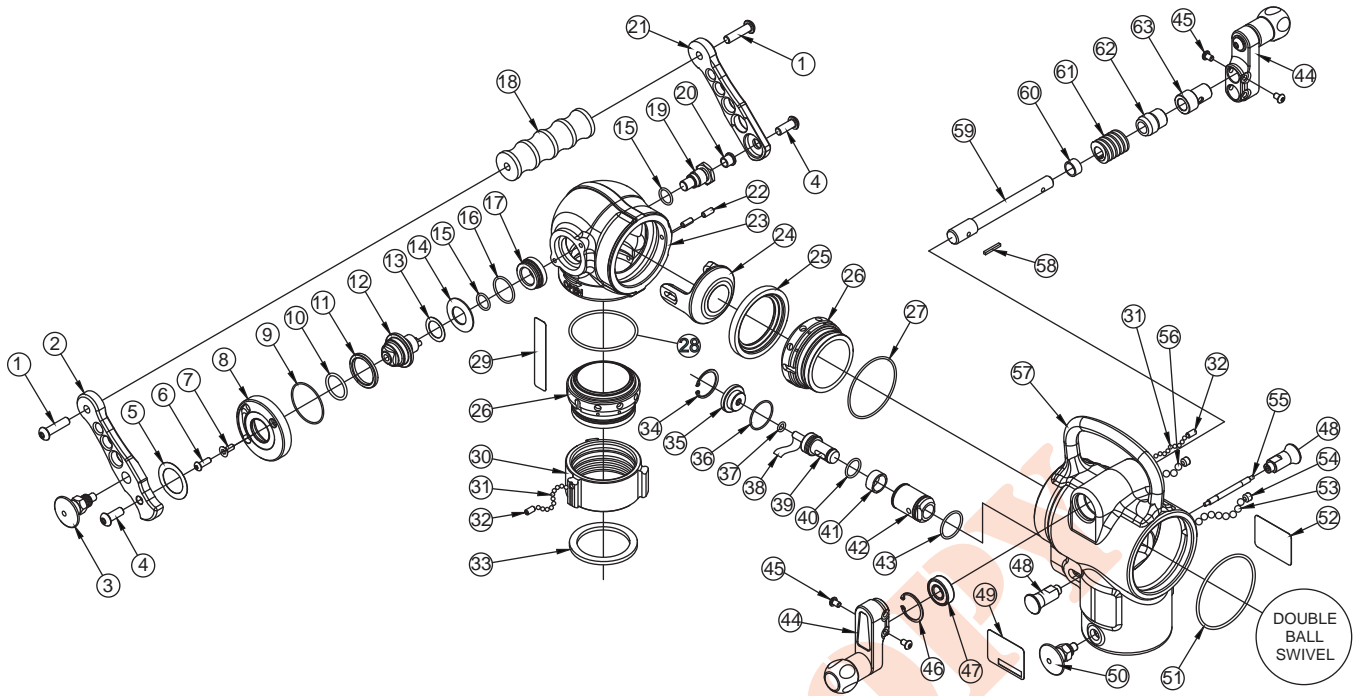

#	DESCRIPTION	QTY.	PART #
1	3/8-16 X 1-1/2 BUTTON HEAD SCREW	2	VT37-16BH1.5
2	DRIVE ARM	1	HE117
3	PULL PIN SUBASSEMBLY	1	XXL902
4	3/8-16 X 1 BUTTON HEAD SCREW	2	VT37-16BH1.0
5	OPEN/CLOSE LABEL	1	HE191
6	1/4-20 X 3/4 BUTTON HEAD SCREW	1	VT25-20BH750
7	1/4-20 X 1/2 FLAT HEAD SCREW	1	VT25-20FH500
8	TRUNNION RETAINER	1	HE110
9	O-RING-033	1	VO-033
10	O-RING-216	1	VO-216
11	BUSHING	1	AY324
12	UPPER TRUNNION	1	HE109
13	WASHER	1	G636-020
14	BELLEVILLE SPRING	1	AY325
15	O-RING-115	2	VO-115
16	O-RING-123	1	VO-123
17	INNER BUSHING	1	HE351
18	HANDLE TOP	1	XX625
19	LOWER TRUNNION	1	HE353
20	FLANGED SLEEVE BEARING	1	HE152
21	FLOATING ARM	1	HE118
22	1/4-20 X 5/8 SOCKET SET SCREW	2	VT25-20SS625
23	2.5" GATED ELBOW BODY	1	HE308
24	HALF BALL	1	AY310
25	VALVE SEAT	1	AY315
26	SIDE B ADAPTER HSBGM30	2	AY365
27	O-RING-151	1	VO-151
28	O-RING-234	1	VO-234
29	WARNING LABEL	1	HE193
30	COUPLING 2.5" ROCKERLUG	1	M307*
31	3/16" SS BALLS (48) PER RACE	96	V2120
32	1/4-28 X 1/2 SOCKET SET SCREW	2	VT25-28SS500

#	DESCRIPTION	QTY.	PART #
33	GASKET - 2.5"	1	V3190
34	RETAINING RING	1	VR4350
35	PLUG	1	HE105
36	O-RING-028	1	VO-028
37	O-RING-109	1	VO-109
38	POSITION INDICATOR LABEL	1	HE193
39	SAFETY LOCK	1	HE104
40	O-RING-117	1	VO-117
41	WAVE SPRING	1	HE150
42	LOCK PIN	1	HE103
43	O-RING-124	1	VO-124
44	CRANK WITH KNOB SUB ASSEMBLY	2	A1629
45	1/4-20 X 3/8 BUTTON HEAD SCREW	4	VT25-20BH375
46	SNAP RING	1	VR4220
47	BEARING	1	VM4250
48	PIN RETRACT LEVER	2	HE107
49	NAME LABEL: HEMISPHERE	1	HE192
50	PULL PIN SUBASSEMBLY	1	HE802
51	O-RING-239	1	VO-239
52	INSTRUCTION LABEL	1	HE194
53	5/16" SS BALL	38	VB.312
54	3/8-24 X 5/16 SOCKET SET SCREW	2	VT37-24SS312
55	PIN RETRACT SHAFT	1	HE106
56	5/16" TORLON BALL	38	VB.312TO
57	BODY	1	HE100
58	KEY	1	X225
59	DRIVE SHAFT	1	HE124
60	SPACER	1	Y4150
61	12 DP WORM	1	X220
62	BUSHING	1	Y3162
63	SHAFT SPACER	1	HE119

* Consult Factory for special threads

DOUBLE BALL SWIVEL PARTS LIST

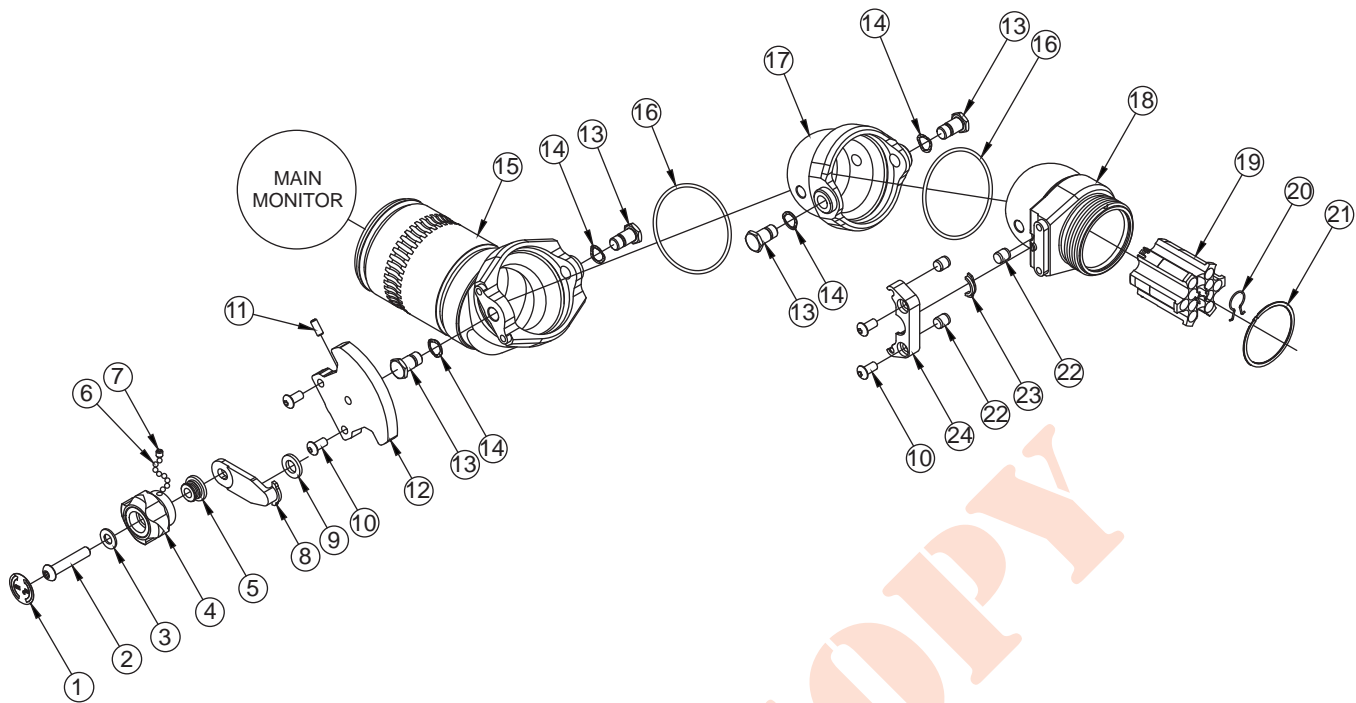

#	DESCRIPTION	QTY.	PART #
1	LOCK/UNLOCK LABEL	1	HE190
2	3/8-16 X 2 BUTTON HEAD SCREW	1	VT37-16BH2.0
3	WASHER	1	VW812X406-65
4	CAM LOCK KNOB	1	HE120
5	3/16 TORLON BALL	12	V2120-TORLON
6	1/4-28 X 1/4 SOCKET SET SCREW	1	VT25-28SS250
7	KNOB BALL RACE	1	HE123
8	CLAMP LEVER	1	HE125
9	WASHER	1	XX364
10	5/16-18 X 5/8 BUTTON HEAD SCREW	4	VT31-18BH625
11	1/4-20 X 5/8 SOCKET SET SCREW	1	VT25-20SS625
12	DOUBLE BALL SWIVEL CAM	1	HE112
13	SWIVEL TRUNNION	4	XX320
14	WAVE SPRING WASHER	4	VW740X550-16
15	BASE/2.5" ANGLED SWIVEL GLUED	1	HE800
16	O-RING-236	2	VO-236
17	BALL SWIVEL MIDDLE SEGMENT 2.5"	1	HE113
18	BALL SWIVEL OUTLET SEGMENT 2.5"	1	HE114
19	EXIT FIN INSERT	1	XXL405
20	EXIT FIN INSERT CLIP	1	XXL407
21	SMALLEY RING	1	V4295
22	CAM LOCK PAD	3	HE121
23	PIVOT COLLAR	1	HE129
24	DOUBLE BALL SWIVEL CAM FOLLOWER	1	HE116

I-BEAM CLAMP PARTS LIST

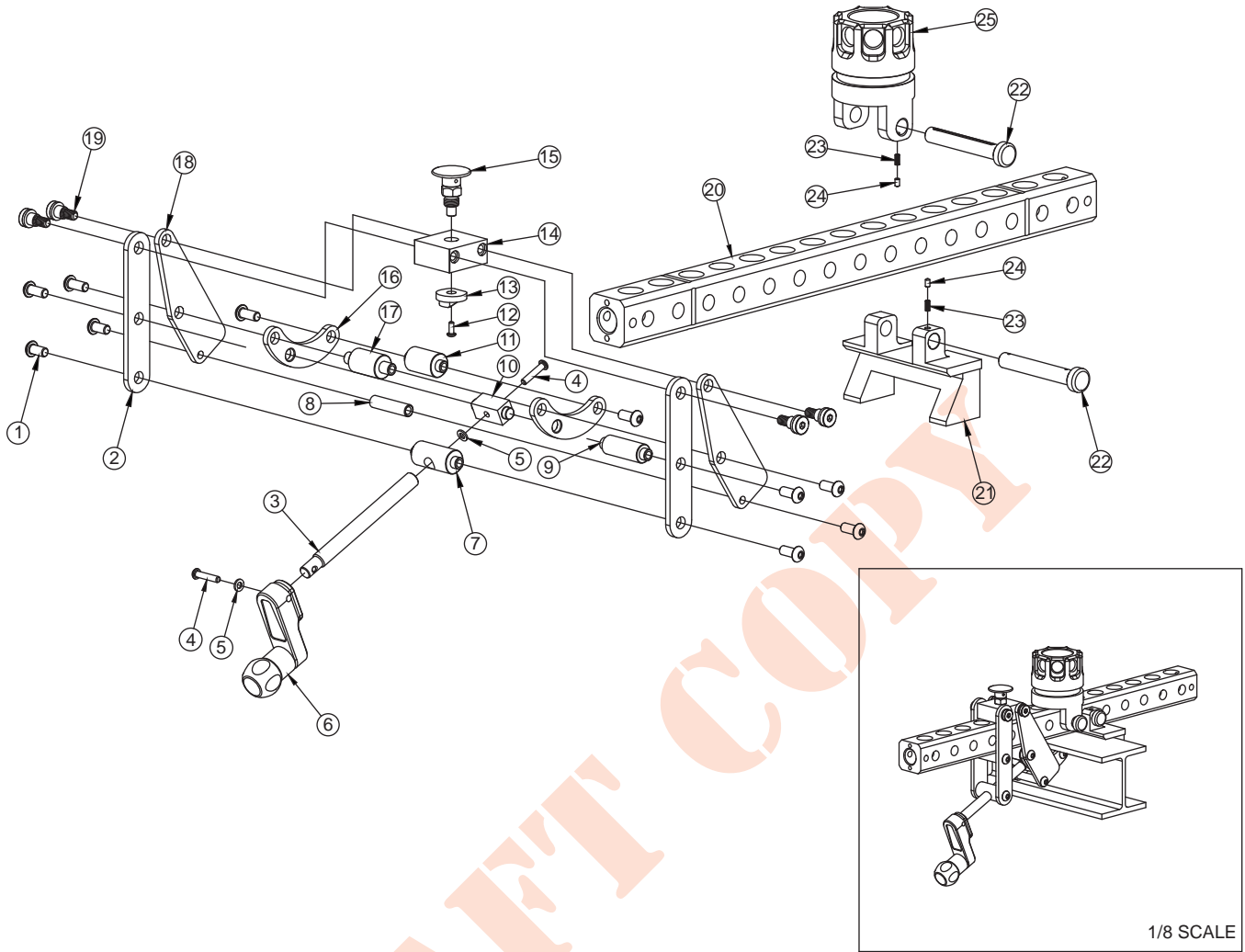

#	DESCRIPTION	QTY.	PART #
1	3/8-16 X 7/8 BUTTON HEAD SCREW	10	VT37-16BH875
2	3 HOLE CLAMPING ARM	2	HE164
3	5/8" DIA. X 7" ROD	1	HE176
4	1/4-20 X 1 1/4 BUTTON HEAD SCREW	2	VT25-20BH1.2
5	WASHER	2	VW500X265-63
6	CRANK WITH KNOB SUB ASSEMBLY	1	HE803
7	FIXED ADJUSTMENT PIVOT	1	HE168
8	1/2" DIA. LINKAGE SPACER	1	HE181
9	.79" O.D. ROLLER	1	HE174
10	ADJUSTER PIVOT BLOCK	1	HE169
11	1" O.D. ROLLER	1	HE166
12	10-24 X 1/2 BUTTON HEAD SCREW	1	VT10-24BH500
13	ADJUSTER PLUNGER	1	HE170

#	DESCRIPTION	QTY.	PART #
14	ADJUSTER BLOCK	1	HE173
15	PULL PIN SUBASSEMBLY	1	HE177
16	CLAMPING ARM	2	HE162
17	1" O.D. ROLLER	1	HE167
18	CLAMPING ARM/JAW	2	HE163
19	3/8-16X.625 L THD SOCKET SHOULDER SCREW	4	VT37-16SB375
20	MOUNTING CLAMP BACKBONE	1	HE160
21	FIXED END	1	HE172
22	CAPTURED MOUNTING PIN	2	HE178
23	SPRING	2	HM552
24	3/16" DIA. LATCH PIN	2	HE175
25	CLAMP MOUNTING BASE	1	HE102A

6.0 WARRANTY

Task Force Tips, Inc., 3701 Innovation Way, Valparaiso, Indiana 46383-9327 USA ("TFT") warrants to the original purchaser of its Hemisphere Monitor ("equipment"), and to anyone to whom it is transferred, that the equipment shall be free from defects in material and workmanship during the five (5) year period from the date of purchase.

TFT's obligation under this warranty is specifically limited to replacing or repairing the equipment (or its parts) which are shown by TFT's examination to be in a defective condition attributable to TFT. To qualify for this limited warranty, the claimant must return the equipment to TFT, at 3701 Innovation Way, Valparaiso, Indiana 46383-9327 USA, within a reasonable time after discovery of the defect. TFT will examine the equipment. If TFT determines that there is a defect attributable to it, it will correct the problem within a reasonable time. If the equipment is covered by this limited warranty, TFT will assume the expenses of repair.

If any defect attributable to TFT under this limited warranty cannot be reasonably cured by repair or replacement, TFT may elect to refund the purchase price of the equipment, less reasonable depreciation, in complete discharge of its obligations under this limited warranty. If TFT makes this election, claimant shall return the equipment to TFT free and clear of any liens and encumbrances.

This is a limited warranty. The original purchaser of the equipment, any person to whom it is transferred, and any person who is an intended or unintended beneficiary of the equipment, shall not be entitled to recover from TFT any consequential or incidental damages for injury to person and/or property resulting from any defective equipment manufactured or assembled by TFT. It is agreed and understood that the price stated for the equipment is in part consideration for limiting TFT's liability. Some states do not allow the exclusion or limitation of incidental or consequential damages, so the above may not apply to you.

TFT shall have no obligation under this limited warranty if the equipment is, or has been, misused or neglected (including failure to provide reasonable maintenance) or if there have been accidents to the equipment or if it has been repaired or altered by someone else.

THIS IS A LIMITED EXPRESS WARRANTY ONLY. TFT EXPRESSLY DISCLAIMS WITH RESPECT TO THE EQUIPMENT ALL IMPLIED WARRANTIES OF MERCHANTABILITY AND ALL IMPLIED WARRANTIES OF FITNESS FOR A PARTICULAR PURPOSE. THERE IS NO WARRANTY OF ANY NATURE MADE BY TFT BEYOND THAT STATED IN THE DOCUMENT.

This limited warranty gives you specific legal rights, and you may also have other rights which vary from state to state.

Visit TFT's web site at www.tft.com