

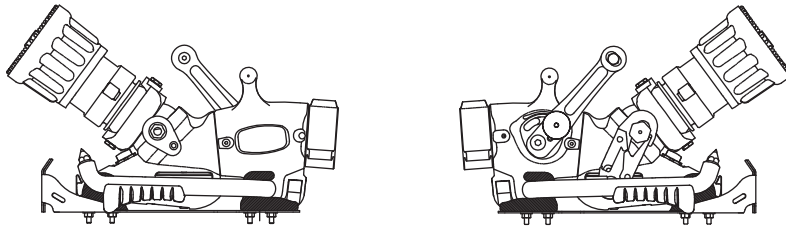

XXL-B Storage Bracket INSTALLATION INSTRUCTIONS

Tools Required: Electric Drill
Drill Bits see instructions for correct size
#3 Phillips Screw Driver
7/16 or adjustable wrench
5/32 allen wrench

The Blitz Lite Portable Monitor storage bracket must be securely mounted to a surface capable of supporting the weight of the Monitor including any shock loads that may result from rough roads. The storage bracket may be mounted on a vertical surface, or a horizontal surface with the nozzle end pointing down or sideways as shown below. It is the responsibility of the installer to determine if the installation is capable of these loads.

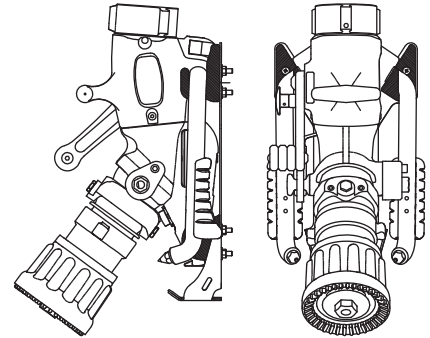

WARNING

Do not use the Blitz Lite Portable Monitor Storage Bracket as a mount when flowing water. Nozzle reaction will cause monitor instability. The Blitz Lite Portable Monitor Storage Bracket is designed to store the Blitz Lite Portable Monitor.

The Blitz Lite Portable Monitor Storage Bracket comes with 1/4-20 Stainless Steel Self tapping screws, nuts and washers. If the material beneath the Storage Bracket is thick and substantial enough, the self-tapping screws may be screwed directly into the mounting surface. If the backside of the mounting surface is accessible, clearance holes may be drilled, and the nuts and washers may be used on the backside. It is the responsibility of the installer to determine if the mounting surface is satisfactory.

FOR BLIND MOUNTING:

Lay the bracket in the area where the monitor will be mounted. The end of the bracket with the bent & welded sides goes toward the monitor outlet. Make sure there is enough clearance to get the monitor in and out of the bracket and that it does not interfere with other equipment on the truck.

Make sure the material beneath the bracket is substantial and thick enough to hold self-tapping screws as well as the weight of the monitor. Make sure the area on the other side of the mounting surface is clear, you don't want to drill into a bundle of wires. We recommend a minimum thickness of 3/32" (.093" - 2.4 mm) in aluminum and 5/64 (.078"-2mm) in steel. Using the bracket as a pattern, drill through one hole into the mounting surface and install one screw. (Put washers on the screws before installing). See the chart on the next page to determine the correct hole size. While the first screw holds the bracket from moving, drill the remaining holes and screw in the remaining screws.

FOR MOUNTING WHERE THE BACK OF THE MOUNTING SURFACE IS ACCESSIBLE:

Lay the bracket in the area where the monitor will be mounted. The end of the bracket with the bent & welded sides goes toward the monitor outlet. Make sure there is enough clearance to get the monitor in and out of the bracket and that it does not interfere with other equipment on the truck.

Make sure the material beneath the bracket is substantial enough to hold the weight of the monitor. Make sure the area on the other side of the mounting surface is clear, you don't want to run a drill into a bundle of wires. Using the bracket as a pattern, drill one 1/4" (.250" - 6.4 mm) diameter hole through the bracket and bolt the bracket to the mounting surface from the backside. (Put the washers on the side with the nuts). While the first screw holds the bracket from moving, drill the remaining holes and screw in the remaining screws. Secure with washers and nuts.

TASK FORCE TIPS, INC.
MADE IN USA • www.tft.com

3701 Innovation Way, Valparaiso, IN 46383-9327 USA
800-348-2686 • 219-462-6161 • Fax 219-464-7155

MOUNTING BRACKET DIMENSIONS

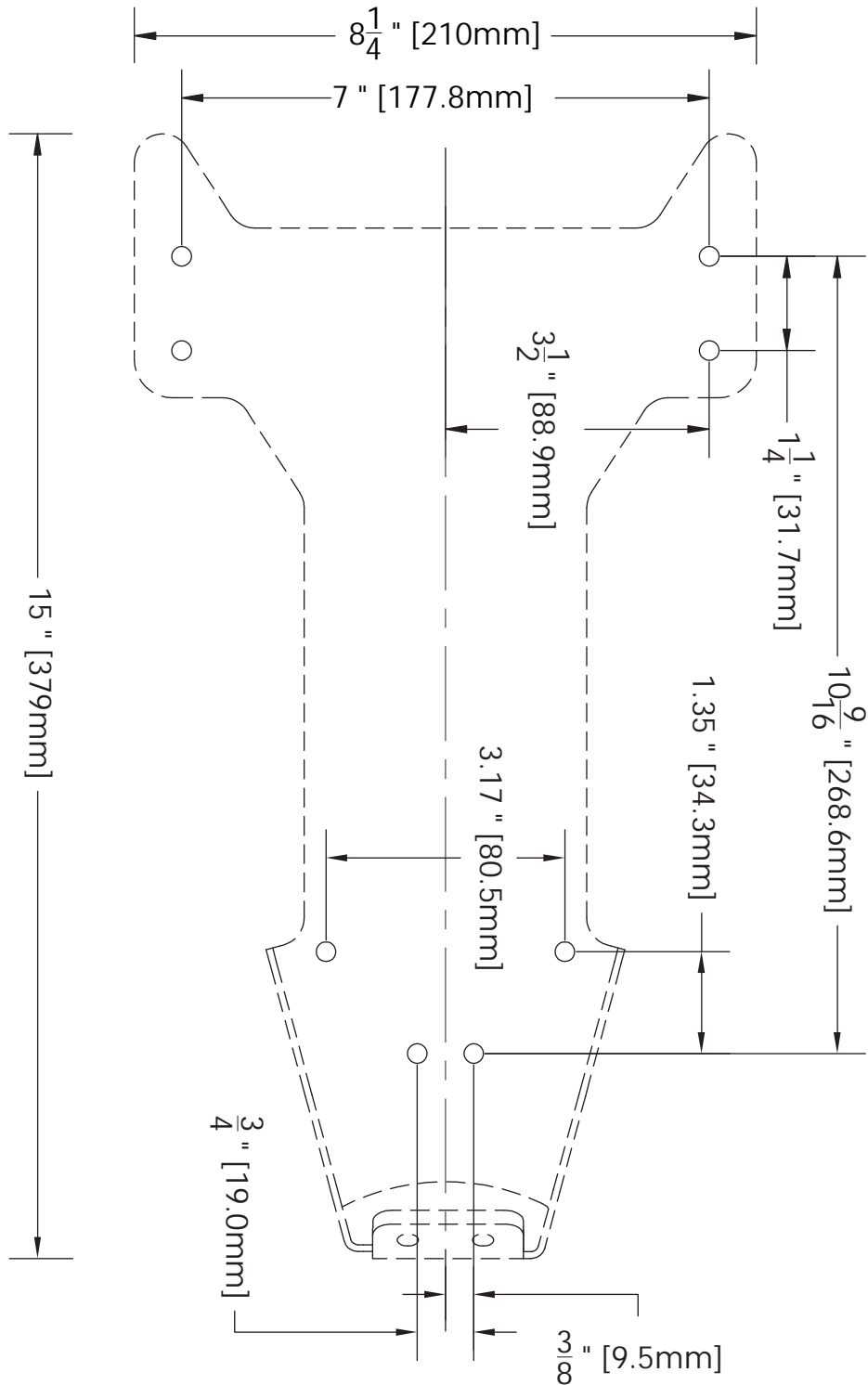

Hole Size Chart for Self Tapping Screws

ALUMINUM				STEEL			
Material Thickness	Inches	mm	Use Drill	Material Thickness	Inches	mm	Use Drill
5/64-3/32	.206	5.2	#5	3/32	.213	5.4	#3
1/8	.213	5.4	#3	1/8	.221	5.6	#2
3/16	.221	5.6	#2	3/16	.228	5.8	#1

DRAWING AND PARTS LIST

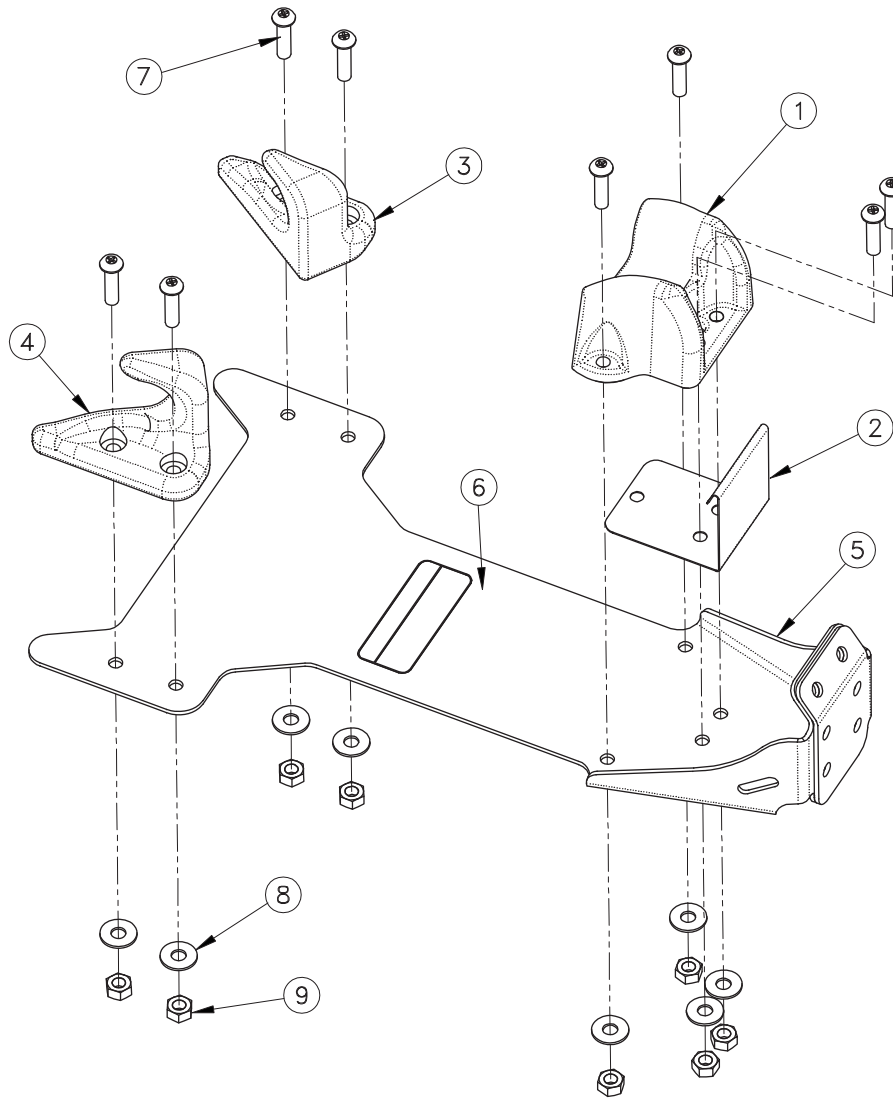

#	DESCRIPTION	QTY	PART#
1	FRONT SPIKE BRACKET	1	XXL491
2	LATCH	1	XX495
3	RIGHT LEG BRACKET	1	XXL492R
4	LEFT LEG BRACKET	1	XXL492L
5	SUPPORT BRACKET	1	XXL494
6	LABEL - STORAGE BRACKET BL	1	XXL695
7	1/4 - 20 x 1 SELF TAP SCREW	8	VT25-20ST1.0
8	1/4 STAINLESS WASHER	8	VW687X281-50
9	1/4 - 20 STAINLESS NUT	8	VT25-20NT

STATEMENT OF WARRANTY AND REPAIR

Task Force Tips, Inc., 3701 Innovation Way, Valparaiso, Indiana 46383-9327 USA ("TFT") warrants to the original purchaser of its nozzles and other equipment ("equipment"), and to anyone to whom it is transferred, that the equipment shall be free from defects in material and workmanship during the five (5) year period from the date of purchase.

TFT's obligation under this warranty is specifically limited to replacing or repairing the equipment (or its parts) which are shown by TFT's examination to be in a defective condition attributable to TFT. To qualify for this limited warranty, the claimant must return the equipment to TFT, at 3701 Innovation Way, Valparaiso, Indiana 46383-9327 USA, within a reasonable time after discovery of the defect. TFT will examine the equipment. If TFT determines that there is a defect attributable to it, it will correct the problem within a reasonable time. If the equipment is covered by this limited warranty, TFT will assume the expenses of repair.

If any defect attributable to TFT under this limited warranty cannot be reasonably cured by repair or replacement, TFT may elect to refund the purchase price of the equipment, less reasonable depreciation, in complete discharge of its obligations under this limited warranty. If TFT makes this election, claimant shall return the equipment to TFT free and clear of any liens and encumbrances.

This is a limited warranty. The original purchaser of the equipment, any person to whom it is transferred, and any person who is an intended or unintended beneficiary of the equipment, shall not be entitled to recover from TFT any consequential or incidental damages for injury to person and/or property resulting from any defective equipment manufactured or assembled by TFT. It is agreed and understood that the price stated for the equipment is in part consideration for limiting TFT's liability. Some states or countries do not allow the exclusion or limitation of incidental or consequential damages, so the above may not apply to you.

TFT shall have no obligation under this limited warranty if the equipment is, or has been, misused or neglected (including failure to provide reasonable maintenance) or if there have been accidents to the equipment or if it has been repaired or altered by someone else.

THIS IS A LIMITED EXPRESS WARRANTY ONLY. TFT EXPRESSLY DISCLAIMS WITH RESPECT TO THE EQUIPMENT ALL IMPLIED WARRANTIES OF MERCHANTABILITY AND ALL IMPLIED WARRANTIES OF FITNESS FOR A PARTICULAR PURPOSE. THERE IS NO WARRANTY OF ANY NATURE MADE BY TFT BEYOND THAT STATED IN THE DOCUMENT.

This limited warranty gives you specific legal rights, and you may also have other rights which vary from state to state

TASK FORCE TIPS, INC.
MADE IN USA • www.tft.com

3701 Innovation Way, Valparaiso, IN 46383-9327 USA
800-348-2686 • 219-462-6161 • Fax 219-464-7155